



**HANDBOOK OF
GREEN BUILDING
DESIGN AND
CONSTRUCTION
LEED, BREEAM, and Green
Globes**

Second Edition

SAM KUBBA PH.D., LEED AP



ELSEVIER

AMSTERDAM • BOSTON • HEIDELBERG • LONDON
NEW YORK • OXFORD • PARIS • SAN DIEGO
SAN FRANCISCO • SINGAPORE • SYDNEY • TOKYO

Butterworth-Heinemann is an imprint of Elsevier



Butterworth-Heinemann is an imprint of Elsevier
The Boulevard, Langford Lane, Kidlington, Oxford OX5 1GB, United Kingdom
50 Hampshire Street, 5th Floor, Cambridge, MA 02139, United States

Copyright © 2017 Elsevier Inc. All rights reserved.

No part of this publication may be reproduced or transmitted in any form or by any means, electronic or mechanical, including photocopying, recording, or any information storage and retrieval system, without permission in writing from the publisher. Details on how to seek permission, further information about the Publisher's permissions policies and our arrangements with organizations such as the Copyright Clearance Center and the Copyright Licensing Agency, can be found at our website: www.elsevier.com/permissions.

This book and the individual contributions contained in it are protected under copyright by the Publisher (other than as may be noted herein).

Notices

Knowledge and best practice in this field are constantly changing. As new research and experience broaden our understanding, changes in research methods, professional practices, or medical treatment may become necessary.

Practitioners and researchers must always rely on their own experience and knowledge in evaluating and using any information, methods, compounds, or experiments described herein. In using such information or methods they should be mindful of their own safety and the safety of others, including parties for whom they have a professional responsibility.

To the fullest extent of the law, neither the Publisher nor the authors, contributors, or editors, assume any liability for any injury and/or damage to persons or property as a matter of products liability, negligence or otherwise, or from any use or operation of any methods, products, instructions, or ideas contained in the material herein.

Library of Congress Cataloging-in-Publication Data

A catalog record for this book is available from the Library of Congress

British Library Cataloging-in-Publication Data

A catalogue record for this book is available from the British Library

ISBN: 978-0-12-810433-0

For information on all Butterworth-Heinemann publications
visit our website at <https://www.elsevier.com/>



Working together
to grow libraries in
developing countries

www.elsevier.com • www.bookaid.org

Publisher: Joe Hayton

Acquisition Editor: Ken McCombs

Editorial Project Manager: Peter Jardim

Production Project Manager: Mohana Natarajan

Cover Designer: Mark Rogers

Typeset by TNQ Books and Journals

DEDICATION

To my mother and father,
Who bestowed upon me the gift of life with love,
And to my wife and four children,
Whose love and affection has inspired me through the years,
And to my friends and colleagues everywhere,
Without whom life would be meaningless and hollow...

PREFACE TO SECOND EDITION

Since its first printing in 2012, *Handbook of Green Building Design and Construction* has provided thousands of professionals and students with invaluable assistance in understanding the concept of sustainability and green construction. Furthermore, the Handbook has also assisted many students and professionals on understanding the importance of being certified (e.g., becoming a LEED™ AP), in addition to helping and explaining to corporations and property owners how to achieve LEED certification for their proposed green building projects.

The sustainability and green building profession has gained tremendous momentum and has had a profound impact on our environment. The second edition of this reference handbook provides a solid foundation for the study of green building design and construction. It explains many of the important tenets of green building and sustainability, while providing the latest strategies for its implementation all designed to broaden the reader's knowledge of sustainability and green building.

This second edition has been revised and fully updated to fill in many of the blanks and questions caused by LEED™ v4. Likewise, this edition takes into account most of the major changes that have taken place in the green building industry over the past two decades.

Sam Kubba, PhD, LEED AP

ACKNOWLEDGMENTS

It would not have been possible for me to produce a book of this size and scope without the active and passive support of many friends and colleagues who have contributed greatly to my thinking and insights during the writing of the first edition of this handbook and this updated edition and who were, in many ways, instrumental in the crystallization and formulation of my thoughts on the subjects and issues discussed within. To them I am heavily indebted, as I am to the innumerable people and organizations who have contributed ideas, comments, and illustrations, that have helped make this book a reality.

I must also unequivocally mention that without the unfailing fervor, encouragement, and wisdom of Mr. Kenneth McCombs, Senior Acquisitions Editor, Elsevier Science and Technology, this book would still be on the drawing board. It is always a great pleasure working with Elsevier. Likewise, I must acknowledge the wonderful work of Mr. Peter Jardim, Editorial Project Manager, Elsevier Science and Technology and thank him for his unwavering commitment and support. I would especially like to salute and express my deepest appreciation to all of the Elsevier team for seeing this updated edition through production and to Mark Rogers for the excellent cover design.

I am particularly indebted to the U.S. Green Building Council (USGBC) and its staff for their assistance, continuous updates, and support on the new LEED Version 4 Rating System and to Ms. Anica Landreneau of HOK for reviewing the original [Chapter 5](#) on Building Information Model. I also wish to express my deep appreciation to Mr. Rob Watson, CEO of EcoTech International for reviewing the original Introduction and [Chapters 1 and 2](#), in addition to his informative comments. And I would be amiss if I failed to acknowledge my wife Ibtesam, for her loving companionship and continuous support and for helping me prepare some of the original line illustrations. Last but not least, I wish to record my gratitude to all those who came to my rescue during the final stretch of this work—the many nameless colleagues, architects, engineers, and contractors who kept me motivated with their ardent enthusiasm, support, and technical expertise. To these wonderful professionals, I can only say, “Thank you.” I relied on them in so many ways, and while no words can reflect the depth of my gratitude to all of them for their assistance and advice, in the final analysis, I alone must bear responsibility for any mistakes, omissions, or errors that may have found their way into this Handbook.

INTRODUCTION



GREEN BUILDING—COMMON MYTHS AND OVERVIEW

The concept of sustainable development and green building is relatively new; indeed, over the past two decades it has become one of the most researched and controversial topics in the field of property development and building design and construction generally. Yet even today a precise definition of what makes a building green tends to elude us. One definition offered by the Office of the Federal Environmental Executive (OFEE) for green building is *“the practice of 1) increasing the efficiency with which buildings and their sites use energy, water, and materials, and 2) reducing building impacts on human health and the environment, through better siting, design, construction, operation, maintenance, and removal — the complete building life cycle.”* The EPA defines green building as, *“the practice of creating structures and using processes that are environmentally responsible and resource-efficient throughout a building’s life-cycle from siting to design, construction, operation, maintenance, renovation and deconstruction.”* Jacob Kriss of the U.S. Green Building Council (USGBC) defines green building as: *“a holistic concept that starts with the understanding that the built environment can have profound effects, both positive and negative, on the natural environment, as well as the people who inhabit buildings every day. Green building is an effort to amplify the positive and mitigate the negative of these effects throughout the entire life cycle of a building.”*

This tells us that green building, when correctly applied, is meant to improve design and construction practices so that the buildings we build last longer, cost less to operate, and will facilitate increased productivity and better working environments for workers or residents. But even more than that, it is also about protecting our natural resources and improving the built environment so that the planet’s ecosystems, people, enterprises, and communities can live a healthier, resource efficient, and more successful lifestyle.

It is no surprise that the general public’s perception of the green movement has changed considerably since its early formative days and is today sweeping across the United States and much of the civilized world. Moreover, sustainable design and sustainable development principles are taking on an increasingly important role by architects and engineers, building

contractors, and in Real Estate applications, particularly by forward looking developers. In fact, many contractors are now seeking green certification and with this in mind, the Associated Builders and Contractors, Inc. (ABC) has recently initiated a program that would certify “Green Contractors.” To achieve the ABC Green Contractor Certification, the following steps need to be followed:

“Step 1: Comply with all prerequisites; meet 12 of the 36 elective items; all fulfill all education and training requirements on application.

Step 2: Submit application, required documentation and application fee to ABC National.

Step 3: ABC National will schedule third-party onsite assessment at applicant’s office. Assessor recommends either certification or additional changes (subject to an additional onsite assessment by third party).

Step 4: ABC National Green Building Committee reviews application and assessment report for certification worthiness.”

ABC uses qualified third-party individuals for the on-site assessment process of certification. And although there are many benefits to acquiring a Green Contractor Certification, nevertheless, some developers refuse to pursue the environment friendly or “Green” building bandwagon. This is mainly due to the misinformation and the misplaced notion that green buildings cost more or that they are impractical to construct. Below are discussed some of the more common myths and misconceptions relating to green building design and construction.



WHAT IS GREEN BUILDING?—COMMON MYTHS AND REALITIES

Even though the public is becoming increasingly aware of the many benefits of sustainable design and green building, nevertheless, there are many persistent myths relating to building green floating in the ether. One example is the myth that sustainable buildings cost more which ignores the most recent research as well as the reality that for any society to thrive and prosper, it is required to achieve a healthy balance between its environmental, social, and economic dimensions. Sustainability is not just about building green but about building a healthy community and sustaining a quality way of life. As a community it is imperative that we actively continue the pursuit of new sources of energy such as wind, solar, and geothermal. With the state of the economy being what it is, these efforts would help create new jobs, attract new businesses, reduce our energy costs, and create a healthy

environment. And although green building has made tremendous strides in recent years, nevertheless it has not received the traction it deserves, given its many benefits. And there remain many who continue to be unconvinced and question its numerous benefits mainly due to the many diverse myths and misconceptions that are circulating around the mainstream construction and real estate industries including:

Myth 1: Building Green is more expensive than conventional construction.

Reality check: This is the biggest myth and is a common misconception that continues to linger on even though it has been debunked many times over. Furthermore, recent research shows that Leadership in Energy and Environmental Design (LEED)-certified buildings can cut greenhouse gas emissions and water consumption by nearly 50%, while costing 25% less to operate and enjoying nearly 30% higher occupant satisfaction and lower interest rates. Of note, on a price per square foot basis, building green may incur marginally greater up-front costs, but when life cycle costs are taken into consideration a green home becomes more affordable and cost-effective partly because the operational costs are lower when compared with conventional buildings. Also, when thinking green is part of the initial planning process, it is easier and less expensive to incorporate features and elements that significantly lower operating and maintenance costs. In fact, by employing various sustainable strategies and approaches, most green building designs end up costing less. The main benefits are achieved by energy saving, increased worker productivity, medical costs (safer indoor air quality for tenants and homeowners), longevity of the building, and a smaller environmental footprint. Additional strategies include reducing waste, optimal value engineering, rightsizing the structure, to using solar panels, low-e windows, and energy-saving appliances, etc., all of which can help qualify a project for a variety of federal tax benefits and incentives. Typical examples of these incentives include but are not limited to: tax credits, grants, expedited building permits, and reductions/waivers in fees. It is surprising therefore that some developers and professionals still believe that building and renovating with green materials to green specifications are cost prohibitive.

Myth 2: Green buildings are typically “unattractive” and lack the aesthetic quality of conventional buildings.

Reality check: This myth is false and is advanced by uninformed and misguided builders and professionals. In fact, there is no reason for a

green/sustainable building to look any different from a conventional building and the majority of today's green buildings are virtually indistinguishable from traditional buildings. Moreover, green renovations of existing buildings should respect its character and if well designed, most likely will not be noticeable from either the interior or exterior. Thus, wood certified by the Forest Stewardship Council looks essentially the same as other types of wood, and when using a vegetated roof, for example, it would not typically be visible from ground level. Moreover, one does not have to mount continuous rows of unattractive solar panels to be green or be obligated to go with solar power, although there are numerous ways to creatively integrate PV (photovoltaic) panels into a project that are both attractive and effective. Likewise, eco-friendly shingles have been found to be more attractive than the common asphalt versions and some renovations are actually invisible, such as extra insulation or a new energy-efficient HVAC system. Also, architect and author Lance Hosey argues in his book, *The Shape of Green: Aesthetics, Ecology and Design* (Island Press, 2012), that the "look and feel" of design are essential to sustainability. He goes on to say that, "If design doesn't appeal to the senses, it's destined to be discarded."

Myth 3: Sustainability is just another fad and therefore not particularly important.

Reality check: Over the last two decades, the world has witnessed an increasing interest in sustainability and a continuous growth in green building and green building certification—so much so that it has now become an integral part of the mainstream in the construction industry, and it is indeed becoming the preferred building method. Furthermore, creating a healthy environment where it does not exist cannot be considered a fad. In the United States, many developers and builders are jumping on the bandwagon, including the US Government. In fact, the US government is the largest builder in the United States and is instrumental in promoting Green Building through design and example. Green Building works in all climates and can benefit the buyer, the seller, and the environment.

Myth 4: Green building is essentially about eco-friendly material selection.

Reality check: This is not factually correct. Green building is mainly concerned with how you design and orient your building, site selection, water conservation and energy performance, window location, etc. However, making smart decisions regarding eco-friendly building

materials such as those possessing high recycled content, low embodied energy, minimal Volatile Organic Compounds, etc., are an important aspect of green building, but they are only a small part of the overall equation. Alex Wilson, President of BuildingGreen Inc. and Executive Editor of *Environmental Building News*, says, “People are beginning to gain a greater understanding that green building is a systems approach to the entire construction process.”

Myth 5: Green buildings do not fetch higher rentals rates or capitals compared with traditional buildings.

Reality check: The exact opposite is true. Recent surveys consistently show that there is a strong market demand for green buildings because they achieved much higher rentals and capitals as a result of reduced operational costs and higher productivity of employees. For example, a recent BOMA Seattle survey concluded that 61% of real estate leaders opine that green buildings enhance their corporate image and the majority of those surveyed believe that tenants are increasingly making the “greenness” of property a significant factor in choosing space. This is reaffirmed by a business case study examining the San Diego real estate market which showed that the overall vacancy rate for green buildings was 4% lower than for nongreen properties—11.7%, compared to 15.7%—and that LEED-certified buildings routinely commanded the highest rents. This clearly shows that tenants and developers do care about green and healthier environment and are willing to pay for it. This trend is already particularly evident in high-end residential projects and flagship corporate office projects and is increasingly becoming widespread.

Myth 6: Green buildings do not provide the comfort levels that many of today’s tenants demand.

Reality check: On the contrary, green buildings are typically more comfortable and healthier than conventional buildings. In fact, one of the chief characteristics of sustainable design is to support the well-being of building occupants by reducing indoor air pollution (from exposure to contaminants such as asbestos, radon, and lead) and therefore avoiding symptoms such as sick building syndrome and building-related illness. This can normally be achieved by selecting materials with low off-gassing potential; proper ventilation strategies; adequate access to daylight and views; and optimum comfort through control of lighting, humidity, and temperature levels. This is not normally the case with traditional building environments.

Myth 7: Green building products are often hard to find.

Reality check: There may have been some truth to this a couple of decades or so ago when it was not unusual having difficulty locating eco-friendly or energy-saving materials, but today, the number of green building products and systems on the market are more popular than ever and have become much more accessible. In the few cases where a green building product is not readily accessible, it may be because it may not be manufactured nationwide or it may be hard to find in certain parts of the country; in such cases, it is usually possible to find satisfactory alternatives. Indeed, the number of green products and systems that are now readily available on the US market has grown exponentially over recent years and continues to grow. So much so that green building products are now in the thousands and have become part of the mainstream. Much information can also be obtained from the various green product directories on the market such as the two comprehensive directories published by Building Green Inc. (*GreenSpec* and *Green Building Products*), which contain performance data and contact information on just about every available green product imaginable. It should be noticed that the availability of green materials and products differs from country to country.

Myth 8: Green building utilizes traditional tools and techniques and not cutting edge technology.

Reality check: The most successful green building design projects generally utilize a multidisciplinary and integrated design approach where a number of consultants and the owner's representative participate as a team and the architect typically takes on the role of team leader rather than sole decision maker. In most cases, locally available materials and techniques are used in addition to the latest technology. This is reinforced by the U.S. Environmental Protection Agency's (EPA's) Website, which clearly states that "Green building research is being done by national laboratories, private companies, universities, and industry." According to a recent USGBC report, in excess of 70% of the green building research is focused on energy and atmosphere research. But the increasing popularity of green building is not just a response to the energy crises or the health crises, but more a natural evolution of the building industry toward greater efficiency, purity, and harmony with nature. Moreover, green buildings have become generally far more efficient and technologically advanced than most traditional buildings.

Myth 9: Green building products are not as efficient as conventional ones.

Reality check: This is totally false in today's green building environment. Examples of typical products that frequently get a bad rap include double-flush and low-flow toilets. This may be because when first introduced, low-flow toilets did not function that well, and some people are still of the opinion that 1.6-gallon-per-flush toilets do not work as well as traditional toilets, even though these fixtures have been mandated for all new construction for many years. In fact, it is the LEED rating system that can take credit for introducing highly efficient toilets, urinals, etc., to thousands of buildings in the United States and globally. The "don't work as well" myth was reinforced with the introduction of compact fluorescent light bulbs, which gave off harsh color, did not last as long as claimed and took too long to light up. Another green building product myth that is often cited relates to fiberglass insulation in that inhaling fiberglass fibers can lead to cancer, which is obviously false. It is therefore important to research unfamiliar products and seek accurate information to back up any efficiency claims prior to formulating a final opinion regarding its suitability or lack of. However, generally speaking, most modern new green products have proved to work better than traditional products, and green products have indeed vastly improved over the years. It should be noted that green materials like traditional building materials also have to meet strict quality control standards, and as the green market continues to grow, new improvements are undoubtedly taking place to improve quality, efficiency, and reliability.

Myth 10: Building green is too difficult and complicated.

Reality check: In reality, nothing is further from the truth; sustainable building is a matter of common sense. In fact, many builders today consider green building to be very easy and compare favorably with conventional building. Moreover, building green is a business that can be very simple and does not require rocket science to implement. Basically, build it smaller, use quality materials that are chosen for sustainability and efficiency, and not for the fad of the month. This may be why many contemporary architects are fascinated with the concept of sustainability and green construction.

Myth 11: It is not possible to build a high-rise green building.

Reality check: Green concepts do not generally inhibit or restrict building design or space usability. Furthermore, all modern techniques that apply to conventional building can be employed in building Green.

A good example of this is the Condé Nast Building (officially 4 Times Square), which is located in Midtown Manhattan. The building boasts 48 stories and rises to 809 ft (247 m). It is environmentally friendly with gas-fired absorption chillers, and a high-performing insulating and shading curtain wall, that keeps the building's energy costs down by not requiring heating or cooling for most of the year. In addition, the building utilizes solar and fuel cell technology, making it the first project of its size to incorporate these features in construction. Another example is the **Bank of America Tower** at One Bryant Park, which is a 1200 foot (366 m) skyscraper also located in the Midtown area of Manhattan in New York City, United States. The building is 55 stories high and contains 2,100,000 square feet (195,096 m²) of office space, three escalators, and 52 elevators. COOKFOX Architects designed the project and who claim the building to be one of the most efficient and ecologically friendly buildings in the world. The design of the building is environmentally friendly, using technologies such as floor-to-ceiling insulated glazing to contain heat and maximize natural light, and an automatic daylight dimming system. The tower also features a gray water system, which captures rainwater for reuse. Bank of America also states that the building is made largely of recycled and recyclable materials. At the time of its completion in 2009, it was the fourth tallest building in New York City (after One World Trade Center, and the Empire State Building) and the sixth tallest building in the United States (Hughes, November 5, 2008).

Myth 12: It is difficult or not possible to convert existing conventional buildings into energy-efficient buildings.

Reality check: It is not really difficult to convert existing buildings into green/sustainable buildings. Actually, there are numerous scientific ratings and checklists that builders can use to redesign and realign traditional buildings to meet modern green standards. According to the premise of Anthony Malkin, President, Malkin Properties, New York City, "overall upgrades and practices are qualitatively the right thing, but not quantitatively. You gain benefits toward sustainability, but you cannot determine a payback period from overall green practices. A true retrofit requires a fact-based, benchmarked, quantitatively oriented, energy-efficiency retrofit with a clear payback analysis on an integrated multi-component effort with performance guarantees." Many rating systems such as LEED for existing buildings, Canada's Go Green Plus, and the Japanese CASBEE certification system all encourage such conversions.

This rising concern for the environment is driving many property owners and developers to seek sustainable solutions. To this end, President Obama upon becoming president has committed his administration to retrofitting 75% of all existing federal buildings. It is important therefore to increase public awareness of how baseless these myths are and do all that is possible to eliminate them.

Myth 13: Going green is an all-or-nothing proposition.

Reality check: Many developers and construction professionals have the misconception that going green with existing buildings involves large-scale remodeling. In fact, the degree and scale of incorporating green into a building is wholly up to the owner, depending on the individual lifestyle and budget. This is reaffirmed by Associated Landscape Contractors of Colorado, who say, “Sustainability is not an all-or-nothing proposition. Every company that tries to go green will not do all the same things as the other company down the street.” Even today, many builders and designers frequently utilize green concepts and green products intuitively and without being fully aware of this. This is however rapidly changing with the increased public and professional awareness and demand for green products, and many manufacturers and the construction industry find themselves rapidly moving in this direction.

Myth 14: Building green requires signing up for a green program or third-party certification.

Reality check: This is definitely not a normal requirement for building green, although certification programs such as Green Globes, BREEAM, and the USGBC’s LEED are excellent vehicles for increasing exposure and furthering the green movement. And keep in mind that the LEED rating system is in most cases a totally voluntary program: you pay your fees, follow the LEED guidelines, and ultimately receive a plaque or certificate stating your building has achieved a Silver, Gold, or whichever status. More importantly, however, it is important to remember that there are many financial and other government incentives to attaining certification. Moreover, building owners and developers can reap the financial benefits of the “greenness” of their building projects by taking advantage of the various tax credits and private and public nontax financial incentives that are available, as well as tenant monetization of reduced operations and maintenance costs and carbon and renewable energy tradable credits. However, it goes without saying that accredited third-party certification can be very helpful and add credibility to any green certification.



THE GREEN MOVEMENT IN HISTORY

The green movement has been significantly transformed since its early formative days. So much so that Jerry Yudelson, author of the *Green Building Revolution*, in fact describes this transformation as “a revolution” sweeping America, Europe, and the world. But for a deeper and more comprehensive understanding of the modern green movement, it helps to try and trace its origins back to the beginning, even though it is almost impossible to determine precisely when a movement may have started. Long before the arrival of the industrial revolution and electrically powered heating and cooling systems, ancient and primitive populations were compelled to improvise using basic tools and natural materials to construct buildings which protected them from the harsh elements and extremes in temperature. Looking back in time, we note that the ancients had few other options at their disposal, which is why before air conditioning was invented, builders living in hot climates developed many different strategies to cope with heat by incorporating passive design that took advantage of the resources provided by nature, namely the sun and climate to heat, cool, and light their buildings. The Babylonians and Egyptians, for example, used adobe as their prime building material and built *badger* (wind shafts) into their palaces and houses. They took advantage of courtyards and narrow alleyways for shade. These are simple examples that illustrate how the ancients overcame the many challenges of climate that faced them.

Many American scholars today like Dr Mark Wilson believe that the concept of green building first appeared in America more than a century ago. According to Wilson, “The revolutionary design philosophy known as First Bay Tradition had its roots in the San Francisco Bay Area in the 1890s. Indeed, the leading practitioners of this environmentally sensitive organic movement, Bernard Maybeck and Julia Morgan, developed a design philosophy that incorporated most of the concepts that are embraced by today’s green movement in architecture.” Some historians associate its beginning with Rachel Carson’s (1907–64) book *Silent Spring* and the legislative fervor of the 1970s or with Henry David Thoreau, who in his book *Marine Woods*, advocates for the respecting of nature and also for an awakening to the need for conservation and federal preservation of virgin forests. Some sustainability scholars believe that the green movement had its roots in the energy crises of the 1970s and the creative approaches to saving energy that evolved from it, such as smaller building envelopes and the use of active and

passive solar design. But it was not until the 1973 OPEC oil crisis eruption that the cost of energy was brought into sharp focus and reminded us that our future prosperity and security was not in our hands, but in the hands of a very select number of petroleum-producing countries (mostly from the Middle East). This catalyzing event effectively highlighted the need for pursuing diversified sources of energy and encourage corporate and government investment in solar, wind, water, and geothermal sources of power. The energy crises artificially created by the imposition of an oil embargo by OPEC in 1973 caused an upward spike of gasoline prices and for the first time, long lines of vehicles at gas stations around the country. This had a dramatic effect on a small group of enlightened and forward-thinking architects, builders, environmentalists, and ecologists, who started to question the wisdom of current conventional building techniques and became inspired to seek new solutions to the problem of sustainability with the help of the latest technological advancements. However, by the 1980s, the enthusiasm for sustainability was fading and lower energy prices were lessening attention to energy-related issues.

This nascent “environmental movement” started to emerge and which was partly inspired by Victor Olgyay’s book “Design with Climate,” Ralph Knowles’s “Form and Stability,” and Rachel Carson’s “Silent Spring”, served notice of the emergence of a new era in environmental design. It also captured the attention and imagination of the general public and caused many to clamor for a broader reexamination of the wisdom of our reliance on fossil fuels for buildings and transportation. This encouraged a number of legislative steps to be initiated to clean up the environment including the Clean Air Act, the National Environmental Policy Act, the Water Pollution Control Act, the banning of DDT, the founding of Earth Day, and the Endangered Species Act.

The American Institute of Architects (AIA) responded to the energy crisis of 1973 by forming an energy task force to study energy-efficient design strategies, and in 1977 President Carter’s administration founded what became the U.S. Department of Energy (DOE); one of its principal tasks was to focus on energy usage and conservation. The energy task force was later to become the AIA Committee on Energy. The Energy Committee prepared several papers, such as *A Nation of Energy Efficient Buildings* which became an effective AIA tool for lobbying Capitol Hill. Among the more active committee members in the late 1970s included Donald Watson, FAIA, and Greg Franta, FAIA, when the AIA, too, was advocating building energy research. The committee also collaborated with government

and other organizations for more than a decade. Committee member Dan Williams says that the Energy Committee formed two main groups: the first researched principally passive systems, such as reflective roofing materials and environmentally beneficial siting of buildings to achieve its goal of energy savings, while the second group primarily concentrated on solutions employing new technologies such as the use of triple-glazed windows. This was later transformed into a more broadly scaled AIA Committee on the Environment (COTE) in 1989, and the following year, the AIA (through COTE) and the AIA Scientific Advisory Committee on the Environment, managed to obtain funding from the recently created EPA which was formed in the wake of elevated concern about environmental pollution. The EPA was established on December 2, 1970 to consolidate in one agency a variety of federal research, monitoring, standard-setting, and enforcement activities to ensure protection of the environment. Its mission included the development of a building products guide based on life cycle analysis and which was published in 1992. As the energy concerns began to subside in the years that followed, partially due to lower energy prices, the momentum for green building and energy-related issues, in general, also gradually weakened but not stamped out due to the dedication of a core group of pioneering architects and professionals who continued to advance their green building energy conservation concept forward. Several notable buildings were constructed during the 1970s which utilized green design concepts such as the Gregory Bateson Building in California (used energy-sensitive PV—solar cells, underfloor rockstore cooling systems, and area climate control devices) and the Willis Faber and Dumas Headquarters in England (utilized a grass roof, daylighted atrium, and mirrored windows).

Numerous oil spills were witnessed during the 1980s such as the Exxon Valdez in 1989, among others, and while the industry presented significant opposition against environmental criticisms, the various energy-related Acts continue to remain in force. We also witness during the 1980s and early 1990s global conservation efforts by sustainability proponents such as Robert Berkebile (Note: a structural failure at the Hyatt Regency Skywalks hotel in Kansas City, which his firm designed caused the deaths of 114 people), William McDonough (Ford Motor Company's River Rouge Plant in Michigan, USA), Sim Van der Ryn (the Gregory Bateson Building in Sacramento, California), and Sandra Mendler (World Resources Institute Headquarters Office, Washington, D.C.) in the United States; Thomas Herzog of Germany (Design Center in Linz, Austria); British architects Norman Foster (Commerzbank Headquarters in Frankfurt, Germany),

Richard Rogers (The Pompidou Centre in Paris, France); and Malaysian architect Kenneth Yeang (the Menara Mesiniaga in Kuala Lumpur, Malaysia). In 1987, the UN World Commission on Environment and Development, under Norwegian Prime Minister Gro Harlem Brundtland, suggested a definition for the term “sustainable development,” as that which “meets the needs of the present without compromising the ability of future generations to meet their own needs.” This was followed by numerous alternative definitions of sustainable development.

President George H. W. Bush took a personal interest in energy issues and in 1991 issued a National Energy Policy, after which AIA President James Lawler convened an advisory group to issue a response and resolution. The resolution which the board passed a month later, called on all AIA members to undertake environmental reforms within their practices, including the immediate cessation of ozone-depleting refrigerants. President Bush reauthorized the Clean Air Act, which requires cleaner burning fuels.

In 1992, Brazil hosted a UN Conference on Environment and Development (also known as the “Earth Summit”) that was held in Rio de Janeiro and which proved to be a great success, drawing 17,000 attendees and delegations from 172 governments and 2400 representatives of nongovernmental organizations. The conference witnessed the passage of Agenda 21 which provided a blueprint for achieving global sustainability. This resulted in the Rio Declaration on Environment and Development, the Statement of Forest Principles, the United Nations Framework Convention on Climate Change, and the United Nations Convention on Biological Diversity. Following on the heels of the Rio de Janeiro Summit, the AIA chose sustainability as its theme for the June 1993 UIA/AIA World Congress of Architects held in Chicago, in which an estimated 10000 architects and design professionals from around the world attended the event. Today, this convention which had the theme of “Architecture at the Crossroads: Designing for a Sustainable Future.” is recognized as a milestone in the history of the green building movement.

In the *Declaration of Interdependence for a Sustainable Future*, it states, “We commit ourselves, as members of the world’s architectural and building-design professions, individually and through our professional organizations, to:

- Place environmental and social sustainability at the core of our practices and professional responsibilities
- Develop and continually improve practices, procedures, products, curricula, services, and standards that will enable the implementation of sustainable design

- Educate our fellow professionals, the building industry, clients, students, and the general public about the critical importance and substantial opportunities of sustainable design
- Establish policies, regulations, and practices in government and business that ensure sustainable design becomes normal practice
- Bring all existing and future elements of the built environment – in their design, production, use, and eventual reuse – up to sustainable design standards.”

The election of Bill Clinton to the presidency in November of 1992 encouraged a number of sustainability proponents to start circulating a grandiose idea of “greening” the White House itself. And on Earth Day April 21, 1993 President Bill Clinton launched his ambitious plans to “greening the White House” and to make the presidential mansion “a model for efficiency and waste reduction.” To put this plan into effect, the President’s Council on Environmental Quality assembled a team of experts that included members of the AIA, the U.S. DOE’s Federal Energy Management Program (FEMP), the U.S. EPA, the General Services Administration, the National Park Service, the White House Office of Administration, and the Potomac Electric Power Company.

The “Greening the White House” initiative created substantial savings (more than \$1.4 million in its first 6 years), primarily from improvements made to the lighting, heating, air conditioning, water sprinklers, insulation, and energy and water consumption reduction. Moreover, the initiative also included a 600,000 sq.ft. Old Executive Office Building that was located across from the White House. There was also an energy audit by the DOE, an environmental audit led by the EPA, and a series of well-attended design charettes consisting of design professionals, engineers, government officials, and environmentalists, with the aim of formulating sustainable energy-conservation strategies using available technologies. Within the first 3 years, these energy-conservation strategies resulted in significant improvements to the nearly 200-year-old mansion such as reducing its annual atmospheric emissions by an estimated 845 metric tons of carbon in addition to an estimated \$300,000 in annual energy and water savings.

Bill Browning, Hon. AIA says, “The process pioneered by the Greening of the White House charrette has become an integral part of the green building movement.” However, the deluge of Federal greening projects was among several forces that drove the sustainability movement in the 1990s. To accelerate this process, President Clinton issued a number of executive

orders, the first being in September, 1998, that directed the Federal government to improve its use of recycled and eco-friendly products (including building products). A second executive order was issued in June 1999 to encourage government agencies to improve energy management and reduce emissions in Federal buildings through the application of better design, construction, and operation techniques. The President issued a third executive order in April, 2000 requiring Federal agencies to integrate environmental accountability into their daily decision-making as well as their long-term planning. The team assembled by the President's Council on Environmental Quality produced important recommendations to preserve the historical presence of the structure as well as maintain and improve comfort and productivity.

During George W. Bush's two terms, during the 8 years of his presidency, greening the White House was taken a little further with the installation of three solar systems, including a thermal setup on the pool cabana that heats water for the pool and showers, and PV panels atop a maintenance shed to supplement the mansion's electrical supply. Bush also made a big push to recycle office paper, although some outside observers are of the opinion that the overall go-green effort lost momentum during his tenure.

The White House greening approaches fit under several main headings:

1. *Building Envelope*: Realizing that a significant amount of energy is lost through building elements like the roof, windows, an effort was made to analyze these and find solutions to increase their efficiency.
2. *Lighting*: Energy-saving light bulbs were utilized wherever possible, and the use of natural light was maximized. Steps were also taken to ensure lights were turned off in empty rooms.
3. *Heating, Ventilation, and Air Conditioning (HVAC)*: HVAC measures were used to reduce the amount of energy needed to heat and cool the buildings while simultaneously increasing occupant comfort. Correct ventilation is necessary to help achieve this.
4. *Plug Loads*: The installation of energy-saving office equipment and replacing refrigerators and coolers with more energy-efficient models.
5. *Waste*: Initiation of a comprehensive recycling program for aluminum, glass, paper, newsprint, furniture, fluorescent lamps, paint solvents, batteries, laser printer cartridges, and organic yard waste.
6. *Vehicles*: Program was initiated to lease vehicles that accept cleaner-burning alternative fuels, and the White House participates in a pilot program to test electric vehicles. Many employees are encouraged to use public transportation to decrease the use of automobiles.

7. *Landscaping*: White House upgrades include methods to reduce unnecessary water and pesticide use and the use of increase organic fertilizers on the grounds of the complex were studied.

The greening of the White House proved to be such a success that it created an underlying demand to green other properties in the extensive Federal portfolio, like the Pentagon, the Presidio, and the U.S. DOE Headquarters as well as three national parks: Grand Canyon, Yellowstone, and Alaska's Denali. In 1996 the AIA/COTE and the U.S. DOE signed a memorandum of understanding to cooperate together on research and development, the objective being to formulate a program consisting of a series of road maps for the construction and development of sustainable buildings in the 21st century.

The onslaught of green activity facilitated individual Federal departments to also make significant headway. For example, the Navy became emboldened and undertook eight pilot projects, including the Naval Facilities Engineering Command (NAVFAC) headquarters at the Washington Navy Yard. In 1997, the Navy also initiated development of an online resource, the *Whole Building Design Guide* (WBDG) whose main mission is that of incorporating sustainability requirements into mainstream specifications and guidelines. A number of other Federal agencies have now joined this project, which is now managed by the National Institute of Building Sciences (NIBS) which is a nonprofit, nongovernmental organization that brings together representatives of government, as well as the professions, industry, labor, and consumer interests.

The green movement's emergence as a significant force was mainly a consequence of many forward looking individuals and groups from all walks of life. As mentioned earlier, visionaries and innovative thinkers have for decades recognized the challenges and need for serious changes in how we react to and treat our environment. The championing of green issues by forward thinking politicians and celebrities played a pivotal role in addressing some of the environmental concerns that captivated the public's imagination during the early years of this century. Hollywood celebrities like Robert Redford were among the earlier true believers and who has been promoting solar energy since the 1970s. Redford has also spent some 30 years on the board of the Natural Resources Defense Council (NRDC), which is described by The New York Times as "One of the nation's most powerful environmental groups." Redford also avidly lobbied Congress in support of environmental legislation and has energetically campaigned on behalf of local initiatives to address climate change and wilderness preservation.

Other Hollywood environmental friendly celebrities who embraced green building and environmental causes include Brad Pitt, Daryl Hannah, Ed Begley Jr., Ed Norton, Cameron Diaz, and Leonardo DiCaprio. This led to a wide array of stars to follow suit and make it an avocation to champion their favorite environmental and green causes, both in the United States and globally.

The green movement was further helped by “green politicians” from mayors to governors, to heads of state, in the United States, and the world over. An excellent example of this is Vice President Al Gore whose release in May 2006 of his academy award winning documentary film *An Inconvenient Truth* is credited with projecting global warming and climate change into the popular consciousness and raised public awareness of many issues including that our quality of life was endangered, that our water was contaminated with toxic chemicals, and that our natural resources were running out. Another well-known eco-friendly politician is California governor Arnold Schwarzenegger who made California a global leader on climate change when he signed into law the historical milestone *Global Warming Solutions Act of 2006*, which commits the state to cut its greenhouse gas emissions by 80% below 1990 levels by 2050. Other eco-friendly politicians include Ralph Nadar, Former Presidential Candidate and a key leader of the Green Party in the United States; the left-wing mayor of London, Ken Livingstone (also known as “Red Ken”) who aimed at making London the greenest city in the world. Livingstone also announced plans for a housing development in East London that would produce no carbon emissions.

Angela Merkel, German chancellor and current leader of the G8, former environment minister, and an outspoken advocate for action against climate change; New Zealand’s prime minister, Helen Clark, who pledged to make Kiwiland the first carbon-neutral country by reducing emissions and offsetting the rest; Former European Union environment minister Margot Wallström (1999–2004) was a leader in convincing every last E.U. member to ratify the Kyoto Protocol in 2002, and an outspoken critic of the United States’s failure to ratify it; from Kenya, we have Wangari Maathai, founder of the Green Belt Movement, which promotes peace and good governance through environmental protection and who has inspired Kenyans to plant 30 million trees since it began in 1977. She is best known as winner of the 2004 Nobel Peace Prize for “her contribution to sustainable development, democracy, and peace.” From China, we have Xie Zhenhua, Chinese Vice Minister of state development and reform and former environment minister. He has promoted environmental protection as a national policy and

sustainable practices for China's rapidly expanding economy. His work was honored with the United Nations' Sasakawa Environment Prize in 2003.

President-elect Barack Obama stated that he plans to make the White House more environmentally friendly to set an example for other Americans. In fact, President-elect Obama has always been an outspoken vocal advocate for sustainability with regard to both the environment and the economic stimulus. He also frequently stressed the need to build a green economy to maintain America's competitive edge in the global labor market, while reducing our impact on the environment. For example, investments in a smart electric grid and energy-efficient homes, offices, and appliances will go a long way to reducing our overall energy consumption as a nation. This partially explains why upon taking office, President Obama put green building at the forefront of his sustainability agenda and proposed expanding federal grants that assist states and municipalities to build LEED-certified public buildings. Jerry Yudelson a well-known green activist believes, "The impact of the Obama administration on green building is going to be to make it a permanent part of the economic, cultural and financial landscape." The President is making great strides toward changing our energy future. And one of his first acts was endorsing the American Recovery and Reinvestment Act of 2009. This would pump more than \$825 billion into the US economy via tax cuts, publicly funded investments in infrastructure and workforce development. This ambitious Recovery Act which President Obama constituted is an unprecedented and historic investment in the clean energy economy and is primarily designed to bolster clean technologies. He also believes that investments in clean energy today will lead to the industries of the future and help put America back in the lead of the global clean energy economy in addition to creating millions of new green jobs in the United States.

Obama first set out his climate ambitions on June 2013, telling students at Georgetown University: "I refuse to condemn your generation and future generations to a planet that's beyond fixing." Since then, President Obama has taken action on all of the goals set out in the plan to cut carbon pollution, prepare the United States for climate change, and help reach a global warming deal. Moreover, in 2015 the president also used his executive power to bring about a great many climate initiatives.

A recent report by climate change consultants ICF International (ICFI) commissioned by Greenpeace reports that the proposed "Green New Deal" environmental measures included in President Obama's \$800bn economic stimulus package is calculated to deliver minimum greenhouse gas emissions

savings of 61 million tons a year, which if correct is very significant as it is the equivalent of taking approximately 13 million cars off the road—and possibly more.

Green movement activist, Lindsay McDuff, says, “When politicians create or formulate policies, the business industries are consequently affected. With the rise in green policy, business executives from every arena are jumping on the green movement bandwagon, basically out of the growing market demand. Being green has become a selling advantage in the business world, and eager companies are starting to jump at the chance to get ahead.” The green movement today has become global and consists of miscellaneous individuals, activist groups, and diverse organizations seeking eco-friendly solutions to global environmental concerns negatively afflicting society and the planet.



OVERVIEW OF GREEN BUILDING AND THE GREEN BUILDING MOVEMENT

Some scholars consider the Green Building movement to be essentially a reaction to the energy crises, and came into being as a result of this, nurtured by efforts to make buildings more efficient and revamp the way energy, water and materials are used. It should be noted that “Green Building” and “Sustainable Architecture” are relatively new terms in our vocabulary; they essentially represent a whole systems approach incorporating a building’s siting, design, construction, and operations in a manner that enhances the well-being of a building’s occupants and preserves the environment for future generations by conserving natural resources and safeguarding air and water quality. The core message therefore, is primarily to improve conventional design and construction practices and standards so that the buildings we build today will not only last longer, but are also more efficient, cost less to operate, and contribute to healthier living and working environments for their occupants, as well as increase productivity.

The advent and implementation of green building and sustainability concepts signals a fundamental change in our approach to how we design and construct buildings today. It is clear that the green building phenomenon has over the last two to three decades, significantly impacted both the United States and global construction markets. Numerous environmental studies have consistently shown that buildings in the United States consume roughly one-third of all primary energy produced and nearly two-thirds of electricity produced. Recent research also shows that roughly 30% of all

new and renovated buildings in the United States contain inferior indoor environmental quality as a result of an unacceptable level of noxious emissions, pathogens, and emittance of harmful substances that are found to exist in traditional building materials. Efforts have been in place for sometime to address these negative environmental impacts including the implementation of modern sustainability practices in green building construction projects. But the implementation and incorporation of sustainable practices into traditional design and construction procedures is an approach that requires redefining and reassessing the current roles played by project participants in the design and construction process to help guarantee effective contribution to a sustainable project's objectives. To achieve a successful sustainable design typically requires applying a multidisciplinary and integrated "total" team approach that incorporates the various project members and stakeholders into the decision-making process, particularly during the early design phases. This holistic team approach helps to ensure that the building project will culminate in a more productive, energy-efficient, and healthier building for both its occupants and its owner. Likewise, the negative impact on the environment will be less than with conventional buildings.

The 1990s saw the introduction of important new environmental rating systems for buildings. And as international awareness of green issues increased, various international conferences were taking place such as the Green Building Challenge (GBC) held in Vancouver, Canada in October 1998, which was led by CANMET Energy Technology Centre of Natural Resources Canada. This event was a well-attended affair with representatives from 14 nations. The goal of these conferences was to create an international environmental rating system for buildings that takes into account regional and national environmental, economic, and social equity conditions.

The green building movement encouraged various parallel efforts to take shape. For example, in the United Kingdom the Building Research Establishment introduced its own environmental building rating system in 1990, known as **BREEAM**, which is one of the world's leading sustainability assessment methods for master planning projects, infrastructure, and buildings. Among other things, it addresses a number of life cycle stages such as New Construction and Refurbishment. According to BREEAM, there are globally now more than 539,400 BREEAM certified developments, and almost 2,233,000 buildings registered for assessment since it was first established in 1990. Indeed, BREEAM sets standards for best practice in sustainable building design and construction and has become a widely recognized measure of a building's environmental performance.

In the United States, we witness the founding of the USGBC, which in 1998, developed the LEED Green Building Rating System. LEED has become the leading and most widely accepted green building rating system in the United States as witnessed by its dramatic growth over recent years.

Additionally, we continue to see a dramatic increase in the number of projects seeking LEED certification from the USGBC, which tends to confirm the significant inroads green building is making into the mainstream design and construction industry. While many builders were initially reluctant to participate in or even encourage the green movement especially during its formative stages, this reluctance rapidly diminished as more and more developers and clients jumped on the green building bandwagon and the construction industry too is now making serious efforts to embrace this initiative. This was reinforced in January, 2016 when Brandon Tinianov, Vice President of business development, joined the USGBC Advisory Council. Mr Tinianov will leverage his industry leadership, extensive experience in sustainability, and perspective to help support the USGBC Board of Directors' efforts to promote environmental and social responsibility around the way buildings and communities are designed, built, and operated. The use of LEED outside the United States also continues to grow rapidly. In fact, as of August 2015, approximately 43% of all square footage pursuing LEED certification existed in countries outside the United States. In the United States, there is more than 13.8 billion square feet of building space that is LEED-certified (*as of August 2015*).

According to Green Building Facts, published by the USGBC (February 23, 2015), "675.9 million square feet of real estate space became LEED certified in 2014, the largest area ever to become LEED certified in a single calendar year, and a 13.2% increase in total certified square-footage from 2013. 2015 looks to be another record-breaking year with 2870 projects certified representing nearly 464 million square feet of real estate as of August 1, 2015." It is no secret therefore that since its inception, the LEED rating system has grown to become an international forum in the United States and some 150 countries and territories around the world including Canada, China, the United Arab Emirates, Italy, Israel, and India. India ranks third globally for countries outside of the United States with the most LEED-certified space, with nearly 12 million square meters, according to a recent report released by USGBC. One of the Indian Green Building Council's declared objectives, for example, was to achieve 1 sq.ft. of green building for every Indian by 2012. The council's chairman, Prem C. Jain, recently stated that India already has an estimated 240 million sq.ft. of green buildings in place.

The Green Building Initiative (GBI) introduced the Green Globes rating system into the United States from Canada in 2004. **Green Globes** is essentially an online green building rating and certification tool that is mostly used in Canada and the USA. BOMA Canada licensed Green Globes for use for existing buildings in Canada and is administered by the GBI for new and existing buildings in the USA. Since then, the assessments have undergone numerous periodic updates including the addition of building types, the most recent included updates to new construction and office fit-ups modules.

As previously mentioned, there has been substantial interest relating to green building issues; yet the amount of money allocated to research of green building has been minimal at best, constituting a mere 0.2% of all federally funded research which roughly comes to \$193 million annually. This amount compares to a meager 0.02% of the estimated \$1 trillion value of buildings annually constructed in the United States, while the building construction industry represents over 10% of the U.S. GDP. The Federal government is one of several relevant funding sources that should be encouraged to provide appropriate financial support to these research programs which have readily attainable strategies. We cannot progress forward toward achieving sustainability unless we significantly improve our green building practices. Failing to do so will have tragic consequences and generate an unduly negative impact on our ecosystem for years to come. To avoid these tragic consequences, the building industry and sustainability professionals need to make a determined effort to find ways of reducing the carbon footprint.

The many challenges we currently face of various sustainability issues, such as global warming, water shortages, indoor environmental quality issues, and destruction of our ecosystem, are mind boggling. It has been clearly documented that conventionally constructed buildings contribute substantially to the environmental problems that are emerging in industrialized countries like the United States, Germany, and China. For example, it has been estimated that current building operations in the United States account for about 38% of its carbon dioxide emissions and 71% of electricity use. Likewise, the Environmental Information Administration (EIA) in 2008 estimated that building operations accounted for almost 40% of total energy use; the latter number increases to an estimated 48% if the energy required making building materials and constructing buildings are included. It is further estimated that buildings annually consume about 13.6% of the country's potable water and according to EPA estimates, wastes from

demolition, construction, and remodeling amount to 136 million tons of landfill additions annually; additionally, construction and remodeling of buildings accounts for 3 billion tons or roughly 40% of raw material used globally each year. And as the population in the United States continues to grow at its current pace from 306 million in 2009 to an estimated 370 million by 2030, the pressure and negative impact on our environment will also continue to increase, unless urgent measures are taken to appropriately adjust consumption patterns to meet these challenges.

Numerous examples of the significant impact that green building research has had and continues to have on society can be seen by the impact of carbon emissions on global warming which continues to receive national and international attention. This has resulted in several organizations like the AIA, ASHRAE, USGBC, and the Construction Specifications Institute, collectively adopting what has become to be known as the 2030 Challenge. This essentially consists of a series of goals and benchmarks for the architectural and engineering community to compare each building's design against the carbon footprint of similar buildings. But the main goal being that all new construction will have net zero carbon emissions by the year 2030, and that an equivalent amount of existing square footage will be renovated to use half of its previous energy use. The 2030 Challenge applies the Commercial Buildings Energy Consumption Survey (CBECS) to benchmark energy use in kBtu per sf; this allows a generalized correlation to the reduction of each building's carbon footprint. This goal will add a new dimension to the use of energy analysis as a tool to predict a building's carbon footprint, and this carbon footprint analysis will likely encourage increased measurement and verification in order to determine the status of each building upon completion. Should a building underperform or not perform according to design expectations, energy modeling, and commissioning groups can diagnose prevailing operation issues in order to determine how best to rectify them.

In March 2007, the United Nations came out with a report: *Buildings and Climate Change: Status, Challenges and Opportunities* that clearly reaffirms buildings' role in global warming. In that respect, Achim Steiner, UN Under-Secretary General and UNEP Executive Director says, "Energy efficiency, along with cleaner and renewable forms of energy generation, is one of the pillars upon which a decarbonized world will stand or fall. The savings that can be made right now are potentially huge and the costs to implement them relatively low if sufficient numbers of governments, industries, businesses, and consumers act." He goes on to say, "This report focuses on the building sector. By some conservative estimates, the building

sector world-wide could deliver emission reductions of 1.8 billion tonnes (1 tonne = 1000 kilograms = 2025 pounds) of CO₂. A more aggressive energy efficiency policy might deliver over two billion tonnes or close to three times the amount scheduled to be reduced under the Kyoto Protocol.” But if we seriously intend to meet the 2030 Challenge, a dramatic change in our current methodology and knowledge of building energy and sustainability issues is required.

Today’s construction industry is facing unprecedented and growing pressures, due partly to a global economic crisis, rising material costs, an increase in natural disasters, and the dramatic impact of the green consumer among other things. Together these trends have motivated the industry to increasingly reevaluate and revise its position by adopting sustainable design and eco-friendly construction methods in a serious effort to build more efficient buildings designed to conserve energy and water, improve building operations, enhance the health and well-being of the general population, and minimize negative impacts on the environment.

Over the years, the market share of green building has continued to develop and increase, partly due to a growing public awareness in addition to the unprecedented level of state and local government interest and initiatives, such as the application of various incentive-based techniques to encourage green building practices. However, these efforts have not been totally successful due to a number of obstacles and challenges that were encountered along the way, particularly the high cost of these new incentive programs, and issues and stumbling blocks relating to implementation and the lack of adequate resources. In an effort to assist communities in overcoming these obstacles, the AIA commissioned a report, *Local Leaders in Sustainability – Green Incentives*, which defines and explains these various programs, scrutinizes the main challenges that must be overcome to succeed, and highlights examples of best practices.



THE U.S. BUILT ENVIRONMENT

The U.S. Census Bureau of the Department of Commerce recently announced that “construction spending during December 2013 was estimated at a seasonally adjusted annual rate of \$930.5 billion, 0.1% ($\pm 1.2\%$) above the revised November estimate of \$929.9 billion. The December figure is 5.3% ($\pm 1.5\%$) above the December 2012 estimate of \$883.6 billion. The value of construction in 2013 was \$898.4 billion, 4.8% ($\pm 1.3\%$) above

the \$857.0 billion spent in 2012.” As for Private Construction, spending “was at a seasonally adjusted annual rate of \$663.9 billion, 1.0% ($\pm 1.0\%$) above the revised November estimate of \$657.1 billion. Residential construction was at a seasonally adjusted annual rate of \$352.6 billion in December, 2.6% ($\pm 1.3\%$) above the revised November estimate of \$343.8 billion. Nonresidential construction was at a seasonally adjusted annual rate of \$311.3 billion in December, 0.7% ($\pm 1.0\%$) below the revised November estimate of \$313.4 billion.

The value of private construction in 2013 was \$627.2 billion, 8.5% ($\pm 1.5\%$) above the \$577.9 billion spent in 2012. Residential construction in 2013 was \$330.7 billion, 18.0% ($\pm 2.1\%$) above the 2012 figure of \$280.3 billion and nonresidential construction was \$296.5 billion, 0.4% ($\pm 1.5\%$) below the \$297.7 billion in 2012.”

In December, the estimated seasonally adjusted annual rate of public construction spending “was \$266.6 billion, 2.3% ($\pm 1.8\%$) below the revised November estimate of \$272.8 billion. Educational construction was at a seasonally adjusted annual rate of \$58.2 billion, 7.2% ($\pm 3.1\%$) below the revised November estimate of \$62.7 billion. Highway construction was at a seasonally adjusted annual rate of \$84.0 billion, 1.8% ($\pm 3.9\%$)^{*} above the revised November estimate of \$82.5 billion. The value of public construction in 2013 was \$271.2 billion, 2.8% ($\pm 1.8\%$) below the \$279.0 billion spent in 2012. Educational construction in 2013 was \$62.4 billion, 8.4% ($\pm 3.1\%$) below the 2012 figure of \$68.2 billion and highway construction was \$81.1 billion, 1.0% ($\pm 4.9\%$) above the \$80.4 billion in 2012.” It should be noted that McGraw-Hill Construction’s name was later changed to Dodge Data & Analytics.

Green projects generally represent a diverse cross section of the construction industry. For example, roofing companies are increasingly making the determination to focus on green technologies that allow their customers to harness the energy rooftop solutions can provide. Most of these companies are however aware that if they are to be successful in meeting the challenges that green technology presents, will require reexamining how their company is to operate, in addition to making a serious commitment financially, in terms of manpower, green technologies, equipment, training, and education in green fundamentals. It also helps to have employees that are LEED certified.

Year after year, we observe an increasingly positive economic impact of new green technologies as is clearly evident in numerous industries such as the plumbing industry which is spurring economic growth for plumbing

contractors around the country. Plumbing contractors are taking an active role and are pursuing actions to take advantage of the sustainable opportunities such as pushing for the installation of water and energy-efficient systems, and through the installation and use of green technologies, to promote energy efficiency and water conservation.

From the very beginning, it was the project designers and property owners/developers as stakeholders, who have played a pivotal role in pursuing sustainable design and green construction practices, and it was they who became the driving force of the built environment concept. With both the source (designer/consultant) and the end user (owner) increasingly adopting sustainable design practices, and with the belief that green building will continue to grow, it became obvious that the contractor/builder had to take on a modified role if green building projects were to be successfully executed; he or she had to become an active member of the project team along with the architect, mechanical/electrical/civil/structural engineer, landscape designer, etc. Experienced builders have much to offer in terms of input on aspects like specifications, system performance, material selection, minimizing construction waste, etc. The contractor can also assist in the achieving of a green project's overall objectives by streamlining construction and applying value engineering practices, etc.

Recent surveys have found that concern over first costs remains the primary barrier to green building. But much of the latest research conducted on the costs and benefits of green buildings come to the same conclusion that energy and water savings on their own, outweigh the initial cost premium in most green buildings and the median increase that green buildings may incur (if at all) is less than 2% when compared with constructing conventional nongreen buildings. This should dispel the myth and public perception that green buildings are much more expensive than conventional buildings. A recently published international study, *Greening Buildings and Communities: Costs and Benefits* concluded that "Most green buildings cost 0–4% more than conventional buildings, with the largest concentration of reported 'green premiums' between 0% and 1%. Green premiums increase with the level of greenness but most LEED™ buildings, up through gold level, can be built for the same cost as conventional buildings."

This report according to Henry Kelly, President of the Federation of American Scientists, "provides the first large-scale data resource on the cost and benefits of green buildings and sustainable community designs." Finally,

Greg Kats, the above study's lead author and a Managing Director of Good Energies one of the study's main supporters, says, "The deep downturn in real estate has not reduced the rapid growth in demand for and construction of green buildings," which "suggests a flight to quality as buyers express a market preference for buildings that are more energy efficient, more comfortable and healthier." This is reaffirmed by the study which determined that productivity and health benefits are a major motivating factor for building green. In fact, according to Harvey Bernstein, Vice President of Industry Insights and Alliances at McGraw-Hill Construction, "The acceleration of the green building marketplace around the world is creating markets for green building products and technologies, which in turn will lead to faster growth of green building." Bernstein currently serves as a member of the Princeton University Civil and Environmental Engineering Advisory Council and is also a member of the Board of Trustees of the National Building Museum and the World Green Building Council.

Finally, a new national green building code has been approved. This new International Green Construction Code (IgCC) that has recently been approved applies to all new and renovated commercial buildings and residential buildings over three stories high. Likewise, The International Code Council (ICC) and ASHRAE have signed the final agreement that outlines each organization's role in the development and maintenance of the new version of the IgCC. The new code, which is scheduled to be released in 2018, will include ASHRAE Standard 189.1, Standard for the Design of High-Performance, Green Buildings Except Low-Rise Residential Buildings developed using the American National Standards Institute (ANSI) approved ASHRAE consensus process.

The IgCC code is indeed a historic code that sets mandatory baseline standards for all aspects of building design and construction, including energy and water efficiency, site impacts, building waste, and materials. The new codes differ from LEED in several ways. For example, the new code creates a mandatory "floor" which stipulates enforceable minimum standards on all aspects of building design and construction that now must be reached. LEED certification, on the other hand, is voluntary, and some building owners do not aspire to achieve it. Therefore unlike LEED and Green Globes certifications, the new US green codes will thus raise the standards for all buildings.

It should be noted that the 2013 California Green Building Standards Code, or CALGreen, established by the California Building Standards

Commission, went into effect January 1, 2014. California first adopted CALGreen in 2010, when it became the first statewide mandatory green building code in the country. The Code establishes minimum green building standards through uniform regulations of most new residential and nonresidential California buildings. The regulations are intended to reduce construction waste, make buildings more efficient in the use of materials and energy, and reduce environmental impacts during and after construction.



Green Concepts and Vocabulary



1.1 GENERAL—THE GREEN BUILDING MOVEMENT TODAY

Green building is increasingly being described as a “movement,” particularly in the United States. This may be partly due to the fact that for some time, sustainable processes such as LEED certification, BREEAM, Green Globes, and others have been rapidly growing and improving as new techniques and sustainable developments are discovered and pursued. And because of this, the construction industry and the architectural/engineering professions both in the United States and globally have witnessed fundamental changes over recent years in the promotion of ecofriendly buildings. These facts have prompted the creation of green building standards, certifications, and rating systems aimed at mitigating the impact of buildings on the natural environment through sustainable design. Moreover, the 1973 oil crisis was a powerful catalyst in spurring the green building movement forward to gain increasing momentum across the various sectors of industry and “green” construction rapidly become the norm on many new construction projects. In fact, many architects, designers, builders, and building owners are increasingly jumping on the green building bandwagon. Numerous national and local programs advancing green building principles are now flourishing throughout the Nation as well as globally. This has helped the green movement to penetrate most areas of our society, including the construction and home-building industries. Nevertheless, Achim Steiner, Executive Director, UNEP, continues to believe that “If targets for greenhouse gas (GHG) emissions reduction are to be met, decision-makers must unlock the potential of the building sector with much greater seriousness and vigor than they have to date and make mitigation of building-related emissions a cornerstone of every national climate change strategy.” Steiner goes further and says, “Public policy is vital in triggering investment in energy efficient building stock, achieving energy and cost savings, reducing emissions, and creating millions of quality jobs. In developing countries where more than 50% of households (up to 80% in rural Africa) have no access to electricity, affordable, energy efficient, low-carbon housing helps address energy poverty.”

Green construction in the United States remains in its relative infancy and is constantly developing. And although the practices and technologies that are utilized in green building construction continue to evolve and improve, they, nevertheless, differ from region to region and from one country to the next. Although this is true, there remain certain fundamental principles that all green projects will conform to. These include: siting, structural design efficiency, energy efficiency, water efficiency, materials selection, indoor environmental quality (IEQ), operations and maintenance, and waste and toxics reduction. Because of this, good environmental stewardship now dictates that our built environment be sustainable. It is no surprise therefore that at the local and state levels, government is increasingly mandating that projects be built to green standards of construction which is driving our industry to become more involved toward making sustainable projects for our clients and communities a priority. This is also because of the pressure from occupants and tenants who have to work and live inside these structures.

While the definition of *sustainable building design* is constantly changing, there are a number of fundamental principles that persist and which will be discussed in detail in later chapters. But, with respect to building green and sustainability, architects and the project team should focus on designing and erecting buildings that are energy efficient, use natural or reclaimed materials in their construction, and are more in tune with the environments in which they exist. Building green means being more efficient in the use of valuable resources such as energy, water, materials, and land than conventional buildings or buildings that are typically built to the latest codes. This is why green buildings are more sympathetic to the environment and provide indoor spaces that occupants find to be typically healthier, more comfortable, and more productive. This is supported by a recent CoStar Group study (CoStar's 25,000-square foot Boston office was awarded LEED Platinum CI in 2010), which concluded that sustainable "green" buildings outperform their peer nongreen assets in key areas including occupancy, sale price, and rental rates, sometimes by wide margins. It should be noted that CoStar is also an ENERGY STAR Partner and was honored in 2009 with an Excellence in ENERGY STAR Promotion Award for incorporating the U.S. Green Building Council's (USGBC) list of LEED-Certified and Registered buildings, ENERGY STAR-Certified buildings, and BREEAM-assessed properties into its database. This has enabled CoStar clients both in the United States and the United Kingdom to implement miscellaneous queries for green buildings and classify buildings with these designations in their corresponding markets.

Sustainability scholars have undertaken numerous studies, all of which clearly show that buildings are the primary sponsors that are impacting our environment—both during the construction phase as well as through their operation. This helps us understand why they have become an area of focus for sustainability investors, developers, and green investment dollars. Research also shows that buildings are the planet's prime consumer of natural resources, which partly explains why we have been recently witnessing a flurry of architects, engineers, contractors, and builders reevaluating how residential and commercial buildings are being designed and constructed. Additionally, we are now seeing various incentive programs around the country and internationally put in place, which encourage and sometimes stipulate that developers and federal agencies go green. It should be noted, however, that while sustainable or green building is basically a strategy for creating healthier and more energy-efficient ecofriendly buildings, i.e., the design of environmentally optimal buildings, it has been found that buildings designed and operated with their life cycle impacts taken into consideration are most often found to provide significantly greater environmental, economic, and social benefits. Moreover, the incorporation of green strategies and materials during the early design phase is the best approach to increase a project's potential market value. Also, incorporating green strategies and materials at the outset of the design phase allows sustainable buildings to amass a vast array of applications and techniques to reduce and ultimately eliminate most of the negative impacts of new buildings on the environment and human health. For example the EPA recently stated that as many as 500 buildings out of the 4100 or so total commercial buildings that have earned Energy Star use a full 50% less energy than average buildings. Moreover, many of the efficiency practices, such as upgrading light bulbs or office equipment, pay for themselves in energy cost savings within a short period of time.

Successful green building programs typically focus on a number of environmentally related categories that emphasize taking advantage of renewable resources, such as natural daylight and sunlight through active and passive solar as well as photovoltaic techniques and the innovative use of plants to produce green roofs, and for reduction of rainwater run-off. But, as previously mentioned, sustainability is typically best achieved when an integrated team approach is used in the building design and construction process. In fact, in today's high-tech world, an integrated team approach to green building has become pivotal to a project's success; this means that all aspects of a project, from the site selection to the structure, to interior finishes, are all carefully considered from the outset before the commencement of the project.

Architects and property developers have come to realize that focusing on a single component of a building can profoundly impact the project negatively with unforeseen and unintended social environmental and/or economic consequences. For example, the design and construction of an inefficient building envelope can adversely impact IEQ in addition to increasing energy costs, whereas a proper sustainable building envelope can help lower operating costs over the life of a building by increasing productivity and utilizing less energy and water. As we have seen, sustainable developments can also provide tenants and occupants with a healthier and more productive working environment as a result of improved indoor air quality (IAQ). Likewise exposure to materials like asbestos, lead and formaldehydes which may contain high volatile organic compound (VOC) emissions are less likely to exist in a green building, thus avoiding potential health problems such as “sick building syndrome” (SBS) resulting from poor IAQ. An interdisciplinary team should therefore be considered a prerequisite to building green.

The main objectives of most designers who engage in green building do so to achieve both ecological and aesthetic harmony between a structure and its surrounding environment. Helen Brown, former board director of the USGBC and a Fellow of Post Carbon Institute, echoes the sentiment of many green proponents and says, “Viewed through a green building lens, conventionally built buildings are rather poor performers. They generate enormous material and water waste as well as indoor and outdoor air pollution. As large containers and collection points of human activity, buildings are especially prodigious consumers of energy. They depend on both electricity and on-site fossil fuel use to support myriad transactions: transporting and exchanging water, air, heat, material, people, and information.”

Rob Watson, author of the *Green Building Impact Report* issued in November, 2008, states that, “The construction and operation of buildings require more energy than any other human activity. The International Energy Agency (IEA) estimated in 2006 that buildings used 40% of primary energy consumed globally, accounting for roughly a quarter of the world’s greenhouse gas emissions (Fig. 1.1a). Commercial buildings comprise one-third of this total. In Fig. 1.1b, we see a pie chart showing US greenhouse gas emissions in 2011 by economic sector. Urbanization trends in developing countries are accelerating the growth of this sector relative to residential buildings, according to the World Business Council on Sustainable Development (WBCSD).” Additionally, it is estimated that buildings account for an about 71% of all electricity consumed in

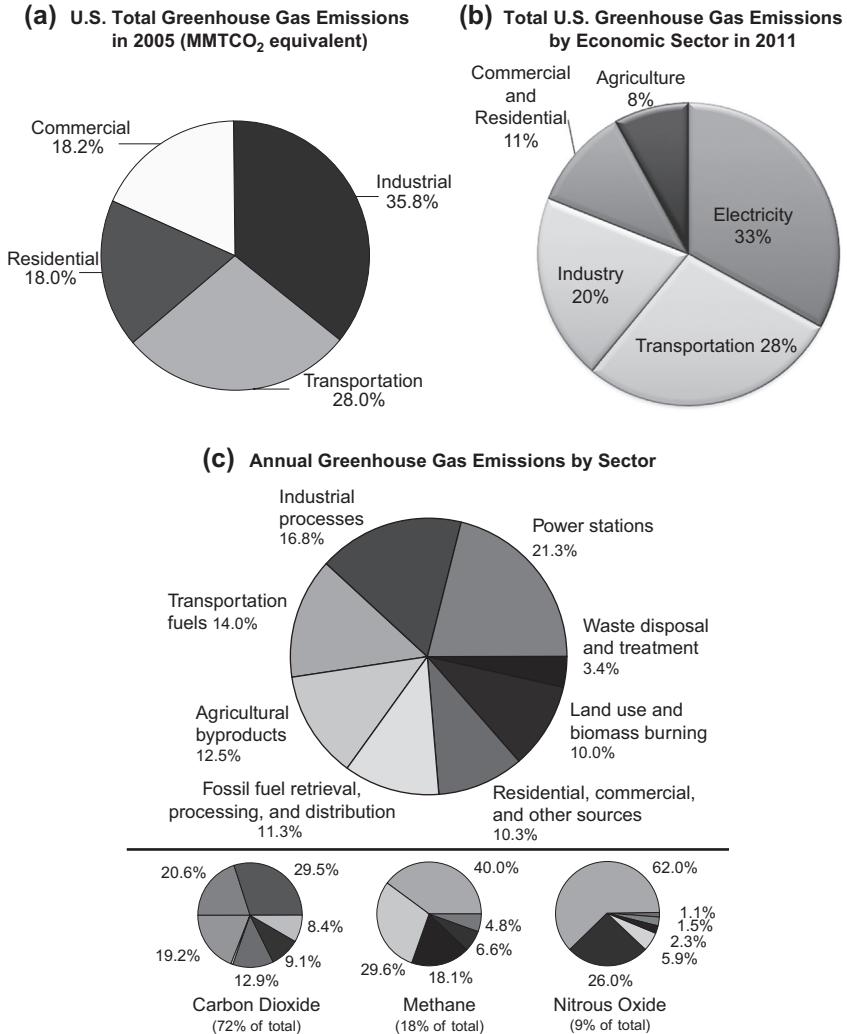

Figure 1.1 (a) Pie chart showing U.S. total greenhouse gas emissions in 2005. The Energy Information Administration (EIA) typically breaks down U.S. energy consumption into four end-use categories: industry, transportation, residential, and commercial. Almost all residential greenhouse emissions are CO₂, which are strongly related to energy consumption. The chart shows that the residential sector generates very little greenhouse gases other than CO₂ and so accounts for only 18% of total greenhouse gas emissions measured in MMT CO₂ equivalents. (b) Pie chart showing total U.S. greenhouse gas emissions in 2011 by economic sector. (c) Global anthropogenic greenhouse gas emissions broken into eight sectors for the year 2000. (a) Source: After National Association of Home Builders—Paul Emrath and Helen Fei Liu. (c) Source: Robert Rohde Wikipedia: Greenhouse Gas.

America and 40% of global carbon dioxide emissions. The impact of building on the US economy is clearly evident from the use of construction materials, e.g., it is estimated that infrastructure supplies, building construction, and road building, make up about 60% of the total flow of materials (excluding fuel) through the US economy. Likewise, studies show that building construction and demolition waste accounts for roughly 60% of all nonindustrial waste. Other building impacts such as water usage show that building occupants consume about 50 billion gallons per day, i.e., over 12% of US potable water consumption. This amount of water consumption is mainly to support municipal, agricultural, and industrial activities which have more than tripled since 1950. Construction also impacts the indoor levels of air pollutants and VOCs in buildings which can be two to five times higher than outdoor levels. It should be noted that in the United States, for example, over 83% of people live in cities and their surrounding metropolitan areas (NRDC, 2014). Many cities are increasingly implementing a variety of sustainability plans, programs, and initiatives, from water policies to climate action to resiliency plans.

Because of this, the design of sustainable buildings today requires the integration of many kinds of information into an elegant, efficient, and durable whole. Thus, the encompassing of sustainable/green building strategies and best practices presents a unique opportunity to create environmentally sound and resource-efficient buildings. And by applying an integrated holistic design process from the outset, this can be achieved, especially by having the stakeholders—architects, engineers, land planners, building owners, and operators, as well as members of the construction industry and consultants from various specialized fields, work together as a team throughout the design of the project. Additionally, the best and most efficient buildings typically result from continual, organized collaboration among all players and stakeholders throughout the building's life cycle. Indeed, today's architects and urban engineers around the world are building cities designed to cope with a future of growing populations, increasingly scarce resources and the need to reduce carbon emissions. We now see examples of future cities debuting in Britain, China, and the U.A.E.

In the forefront of the green building offensive is the federal government which is the nation's largest single landlord. In fact, the Federal government has for some time been a leader in constructing green buildings, and LEED has been the Federal standard of choice. Moreover, the Department of Energy (DOE) issued a final rule on October 14, 2014 updating its recommended

certification standards and levels for all Federal buildings. It is well known that the General Services Administration (GSA) was one of the first adopters of LEED-NC. The GSA became committed to incorporating principles of sustainable design and energy efficiency into all of its building projects. It is the intent of the GSA that sustainable design will be integrated as effortlessly as possible into the existing design and construction process. In this regard the GSA recently announced that it will be applying more stringent green building standards to its \$12 billion construction portfolio which includes more than 361 million square feet of space in 9600 federally owned and leased facilities occupied by more than 1.2 million federal employees and consisting of post offices, courthouses, border stations, and other buildings. The GSA decided to use the Leadership in Energy and Environmental Design (LEED) Green Building Rating System of the USGBC as its tool for evaluating and measuring achievements in its sustainable design programs. In keeping with the spirit of sustainability, the GSA recently increased its minimum standard requirement for new construction and substantial renovation of Federally owned facilities by adopting the LEED Gold standard, which is the next highest level of certification (just below Platinum). Until recently, the GSA had only required a LEED Silver certification. In justifying this move, Robert Peck, GSA Commissioner of Public Buildings stated, “Sustainable, better-performing federal buildings can significantly contribute to reducing the government’s environmental footprint,” and “This new requirement is just one of the many ways we’re greening the federal real estate inventory to help deliver on President Obama’s commitment to increase sustainability and energy efficiency across government.”

The CEO and Founding Chairman of the USGBC, Richard Fedrizzi echoed the Federal government’s lead in adopting green building practices when he said, “The Federal government has been at the forefront of the sustainable building movement since its inception, providing resources, pioneering best practices and engaging multiple Federal agencies in the mission of transforming the built environment.” A first-ever “White House Summit on Federal Sustainable Buildings” conference was held on January 24–25, 2006. This summit attracted over 150 Federal facility managers and decision makers in addition to 21 government agencies to formulate and witness the signing of the “Federal Leadership in High Performance and Sustainable Buildings Memorandum of Understanding (MOU)”. Agencies that signed this MOU all committed to federal leadership in the design, construction, and operation of high-performance and sustainable buildings. The signing of the MOU highlights the sense

of urgency felt by green building proponents and represents a significant accomplishment by the federal government through its collective effort to define common strategies and guiding principles of green building. To consolidate these goals, the signatory agencies will now need to coordinate with complementary efforts in the private and public sectors. This implies that the Federal government is making an unswerving commitment to designing, maintaining, locating, in addition to constructing, and operating its facilities in an energy efficient and sustainable manner. The objective is to achieve a balance that will realize optimal standards of living, more comprehensive sharing of life's amenities, maximum attainable reuse, and recycling of diminishing resources, in a manner that is consistent with and meets the objectives of the Department and Agency missions. According to the Whole Building Design Guide (WBDG), "The Federal government owns approximately 445,000 buildings with total floor space of over 3.0 billion square feet, in addition to leasing an additional 57,000 buildings comprising 374 million square feet of floor space. These structures and their sites affect our natural environment, our economy, and the productivity and health of the workers and visitors that use these buildings." (© 2016 National Institute of Building Sciences).

The above is a clear indication that the gap between green and conventional construction is narrowing and is another sign that green construction has come of age, especially when we learn that currently there are more than 80 green building programs operating in the United States alone, not including numerous other countries like Canada, Japan, China, India, Australia, the U.A.E., and the United Kingdom. A measure of the growth of green building programs and its success is reflected by the number of cities that have established or adopted such programs. For example, the American Institute of Architects (AIA) reported that by 2008, there were 92 cities with populations greater than 50,000 that had established green building programs, up from 22 in 2004, a 318% increase. Many of the programs in the United States are either city, county, or state programs; there are also three that are national in scope. The three national green building programs in the United States are the LEED program of the USGBC, the Green Globes program of the Green Building Institute (this program was designed by the UK Building Research Establishment), and the National Green Building Standard of the National Association of Home Builders. In the United States, the LEED program is the most widely recognized, but all of these programs were developed and operate outside of government.

The USGBC has recently announced that, as of November 2010, the footprint of LEED-certified commercial space in the United States has surpassed 1 billion square feet. This is in addition to another 6 billion square feet of projects around the world that are registered and working toward certification. It should be noted that while not all projects that register with LEED achieve certification, nevertheless, the milestone remains a significant one. “The impact of these one billion square feet resonates around the world,” said Peter Templeton, president of the Green Building Certification Institute (which certifies LEED projects). One example of where LEED codes are mandated is in the District of Columbia which has some of the strongest green building codes in the country; likewise, the D.C. area has the most LEED-certified space per person in the United States and one of the highest concentrations of LEED professionals in the nation.

Lastly, Chicago’s hosting of the USGBC’s annual Greenbuild International Conference and Expo (for the second time), proved to be a great success and united many people from different countries, different backgrounds, and different professions around a single common cause: building a better, healthier, more sustainable world. Greenbuild is the premier event for sustainable building and is the world’s largest conference and expo dedicated to green building. The three-day conference normally attracts more than 20,000 attendees and 600 exhibitors annually from across the green building sector, spanning commercial and residential professionals, architects, building owners and operators, students, advocates, and educators. The 2015 conference took place at the Washington Convention Center in Washington, D.C. on November 18, 19, and 20.

Following the Chicago conference, Rick Fedrizzi said, “For years, we’ve asked ourselves: Can we build it taller? Can we build it faster? Can we build it cheaper? At the USGBC, we ask a different question: Can we build it better? Can we build in ways that are more sustainable, more energy efficient and that provide clean air and good lighting? In ways that can create jobs, restore our economy, and build healthier, more livable communities?” Kate Hurst, vice president, community advancement, conferences and events, USGBC says, “Many factors are considered in regards to the location of Greenbuild, including the sustainability climate of the city we’re considering.” She goes on to say, “The selected cities are conducive to sustainability and the mission of Greenbuild – from walkability of the convention center area and public transportation options to initiatives currently taking place within each city – all these factors contribute to our ultimate decision.”



1.2 GREEN BUILDING BASICS—WHAT MAKES A BUILDING GREEN?

It has never been easy to give a precise definition of the term “green building” or “sustainable building,” especially since they are relatively new additions to our vocabulary. Green/sustainable building is also known by some as “high-performance building.” The California Department of Resources Recycling and Recovery (CalRecycle), for example, defines it as “a structure that is designed, built, renovated, operated, or reused in an ecological and resource-efficient manner. Green buildings are designed to meet certain objectives such as protecting occupant health; improving employee productivity; using energy, water, and other resources more efficiently; and reducing the overall impact to the environment.” The EPA on the other hand, defines it as, “the practice of creating structures and using processes that are environmentally responsible and resource-efficient throughout a building’s life-cycle from siting to design, construction, operation, maintenance, renovation, and deconstruction.” This practice expands and complements the classical building design concerns of economy, utility, durability, and comfort. Still another definition for sustainable development was offered at the Gothenburg European Council meeting of June 2001, “as a means of meeting the needs of the present generation without compromising those of the future.” But, however, one wishes to define the term, green building or sustainable development has had a profound impact on the U.S. and global construction market over the last two decades, although it may be several years before we can ascertain the full impact on the building construction industry and its suppliers. However, since there is no uniform definition of green, it is essential that every “green” term in the contract is specifically defined and that agreed-to objective standards of performance are established in the contract. For example, when specifying explicit energy efficiencies requirements, they should be outlined in a carefully drafted and technically correct and verifiable manner.

While the United States remains the undisputed global leader in the construction of green buildings, we are witnessing a sharp increase in countries around the world that are investing in sustainability and jumping on the green bandwagon. The European Union (EU), for example, has agreed on a new sustainable development strategy that has the potential to determine how the EU economy evolves in the coming decades. In addition to the USGBC’s LEED rating system, there are many other green building

assessment systems currently being used around the world, such as Building Research Establishment's Environmental Assessment Method (BREEAM), Comprehensive Assessment System for Building Environmental Efficiency (CASBEE), Green Globes US, and Green Building (GB) Tool (Mago and Syal, 2007).

As previously stated, green building strategies relate primarily to land use, building design, construction, and operation that together help minimize or mitigate a building's overall impact on the environment. The chief objectives of green buildings is therefore to increase the efficiency with which buildings utilize available natural resources such as energy, water, and materials, while simultaneously, minimizing a building's adverse impact on human health and the environment. There are numerous strategies and approaches that can be used in green construction that can be employed in the construction of a new building designed for long-term operations and maintenance savings. Moreover, the United States has a vast number of existing buildings that can be made greener and more efficient, and studies show that many property owners have shown considerable interest in exploring this possibility of adopting green principles.

However, as discussed in the Introduction and echoed by Leah B. Garris, senior associate editor at Buildings magazine, "Myth and misinformation surround the topic of sustainability, clouding its definition and purpose, and blurring the lines between green fact and fiction." Remarking on aspects of aesthetics, the well-known green building proponent, Alan Scott, principal, Green Building Services in Portland, OR says, "You can have a green building that doesn't really 'look' any different than any other building." Ralph DiNola, also a principal with Green Building Services reaffirms this statement, believing that a level of sustainability can easily be achieved by designing a green building that looks "normal." DiNola goes on to say that "People don't really talk about the value of aesthetics in terms of the longevity of a building. A beautiful building will be preserved by a culture for a greater length of time than an ugly building." Thus a building's potential longevity is one of sustainability's principle characteristics, and aesthetics is an important factor in helping achieve this.

To understand sustainability, one really needs to understand nature and how to work in harmony with it and not against it. It certainly is not about constructing structures that purport to be environmentally responsible but that in reality sacrifice tenant/occupant comfort. This does not imply that purchasing green products or recycling assets at the end of their useful lives is not sustainable, because it is. It is also appropriate for both the environment

and for the health of a building's occupants. However, before making a final determination, a developer or building owner should first take the time to research the various options available that are most appropriate for the project and which would offer the best possible return on investment. This will also ensure that the wrong decisions can be avoided.

It should be noted that many green professionals believe that sustainability starts by having a thorough understanding of the climate and the primary reason that green strategies are considered green is largely because they work in harmony with the surrounding climatic and geographic conditions that exist and not against them. However, this necessitates a thorough understanding of the environment in which a project is being designed to fully apply this information to a project's advantage. Most architects and designers who specialize in sustainability and green building are fully aware of the need to being familiar with year-round weather conditions such as temperature, rainfall, humidity, site topography, prevailing winds, indigenous plants, etc., to succeed in sustainable design. And although climate impacts sustainability in a number of ways, partly depending on the project's location, measuring the degree of a project's success in achieving sustainability can be made by comparing its performance to a baseline condition that relates to the microclimate and environmental conditions of the project's location. Additionally, to successfully achieve sustainability, it is necessary to identify and minimize a building's need for resources that are in short supply or locally unavailable and encourage the use of readily available resources such as the sun, rainwater, wind, etc. A thorough understanding of the microclimate where the project is located is imperative because it reflects a comprehension to what is and what is not readily available at a project's disposal such as the sun for heating and lighting, the wind for ventilation, and rainwater for irrigation, and other water requirements. CalRecycle, for example, cites the main elements of green buildings and sustainability as:

Siting: This includes selecting a suitable site that takes advantage of mass transit availability. This will include the protection and retention of existing landscape and natural features. Plants should be selected that require low water and pesticide needs and that generate minimum plant trimmings.

Water Efficiency: This can be achieved by applying certain water efficiency strategies which according to CalRecycle include designing "for dual plumbing to use recycled water for toilet flushing or a gray water system that recovers rainwater or other nonpotable water for site irrigation" and "Minimize wastewater by using ultra low-flush toilets, low-flow shower heads, and other water conserving fixtures." In addition, CalRecycle suggests the use of recirculating systems for centralized hot

water distribution, and the installation of point-of-use hot water heating systems for more distant locations. The landscape should be metered separately from the buildings, and microirrigation should be used to supply water in nonturf areas. Whenever possible, state-of-the-art irrigation controllers and self-closing nozzles on hoses should be used.

Energy Efficiency: To achieve optimum building energy performance and energy efficiency, a number of passive design strategies need to be employed such as utilizing a building's size, shape and orientation, passive solar design, and taking advantage of natural lighting. Alternative sources of energy should be considered such as photovoltaics and fuel cells which are now widely used and readily available. Renewable energy sources are a sign of the emerging technologies of the future. Computer modeling has also become part of the mainstream and is a very helpful tool in energy calculations and optimizing the design of electrical and mechanical systems and the building envelope. These are discussed in greater detail in other sections of the book.

Materials Efficiency and Resource Conservation: This necessitates the selection of construction materials and products on the basis of key characteristics such as reused and recycled content, zero or low off gassing of harmful air emissions, zero or low toxicity, sustainably harvested materials, high recyclability, durability, longevity, and local production. Likewise, the incorporation of dimensional planning and other material efficiency strategies will increase sustainability as well as the reusing recycled construction and demolition materials.

Environmental Air Quality (EAQ): Studies show that buildings with good overall IAQ can reduce the rate of respiratory disease, allergy, asthma, sick building symptoms and increase worker productivity. In addition to adequate ventilation, construction materials and interior finish products should be chosen with zero or low emissions to improve IAQ. Many building materials and cleaning/maintenance products emit toxic gases, such as VOCs and formaldehyde. These gases can have a harmful impact on occupants' health and productivity.

Building Operation and Maintenance: Commissioning of green buildings upon completion ensures that they perform according to the design goals that were intended. Building commissioning includes testing and adjusting the mechanical, electrical, and plumbing systems to certify that all equipment meets design criteria. It also requires instructing the staff on the operation and maintenance of equipment. Proper maintenance allows a building to continue to perform at optimum levels and as designed and commissioned.

Water conservation and energy efficiency both rely heavily on the climate, whereas indoor environment quality and materials and resource conservation are largely independent of climate. And while site sustainability will depend on climate to some degree, and more specifically on the specifications and microelements that are particular to a specific site, it is important to note that different regions or locations may encounter diverse climates—from hot, arid to humid, freezing, and windy. Therefore, understanding a region's climate and readily available resources are important as this can help avoid applying inappropriate techniques to a project which may have an adverse impact and invariably increase the costs and feasibility of the project.



1.3 INCENTIVES, BARRIERS, AND BENEFITS OF GOING GREEN

Since the oil crisis of the 1970s, but particularly over the last two decade or so, architects, designers, constructors, and building owners have increasingly taken an interest in green building. Sustainability and the green building movement today is flourishing throughout the United States and globally due mainly to the increasing demand for green buildings and greening existing buildings (partly a result of public awareness of its benefits, and also federal and national laws recently put in place) and in addition to the many national and local programs in place offering various incentives. Thousands of projects have been constructed over recent years which provide tangible evidence of what green building can accomplish in terms of resource efficiency, improved comfort levels, aesthetics, and energy efficiency. One example is Montgomery County Government (Maryland, U.S.), which along with local utilities and other government agencies now offer a range of financial incentives to help businesses reduce their ecological footprint and contribute to the green economy.

Below are some of the primary benefits of building green, which are not always easily quantifiable and therefore are not typically adequately considered in cost analysis:

- Reducing energy consumption
- Reducing pollution and protection of ecosystems
- Improved occupant health and comfort
- Increased productivity
- Reducing landfill waste

The Dutch economist Nils Kok has published what is reportedly the most comprehensive statistical analysis to date on the relative value of

green and conventional buildings. The study concludes that U.S. buildings labeled under the LEED or Energy Star programs charge 3% higher rent, have greater occupancy rates, and sell for 13% more than comparable properties. According to the study, "Labeled buildings have effective rents (rent multiplied by occupancy rate) that are almost 8% higher than those of otherwise identical nearby non-rated buildings." As for residential buildings, McGraw-Hill Construction's 2008b SmartMarket Report, "*The Green Home Consumer*" says that 70% of homebuyers are more or much more inclined to buy a green home over a conventional home in a depressed housing market. That number is 78% for those earning less than \$50,000 a year; moreover, the study shows that 56% of respondents who bought green homes in 2008 earn less than \$75,000 per year, and 29% earn less than \$50,000.

What is interesting to note is that studies have also shown that buildings' operating costs normally represent only 10% or less of an organization's cost structure, whereas personnel usually constitute the remaining 90%. This lends strong credence to the view that even minor improvements in worker comfort can result in substantial dividends in performance and productivity. Likewise, there is substantial evidence linking high-performance buildings with improved working conditions; this in turn typically leads to reduced turnover and absenteeism, increased productivity, improved health, and other benefits. These benefits have become major contributing factors to the growth of building efficiency, particularly with respect to the occupants and tenants that have to live and work inside these buildings.

Although the global economic recession sometimes tends to dominate year-end headlines, we nevertheless see a cascade of newly released studies and reports that point to green building as one of the growing bright spots for the U.S. economy. With regard to existing buildings, more than 80% of commercial building owners have allocated funds to green initiatives according to a "2008 Green Survey: Existing Buildings," a survey jointly funded by Incisive Media's Real Estate Forum and GlobeSt.com, the Building Owners and Managers Association (BOMA) International, and the USGBC. The study furthermore concluded that nearly 70% of commercial building owners have already implemented some form of energy monitoring system. The survey also confirmed that energy conservation is the most widely employed green program in commercial buildings, followed by recycling and water conservation. In addition, the study shows that 45% of respondents plan to increase sustainability investments in 2009,

and that 60% of commercial building owners offer education programs to assist tenants in implementing green programs in their space, up 49.4% from the previous year.

Another study recently conducted by the Henley University of Reading in the United Kingdom, concludes that commercial building owners can reap higher rental premiums for green buildings of about 6% if the buildings enjoy LEED or Energy Star certification. This study also concludes that the more highly rated that a building is, the higher the rental premium. The study also suggests the presence of a sales price premium of about 35% based on 127 price observations of LEED-rated buildings, and 31% premium based on 662 price observations of Energy Star-rated buildings. Andrew Florance, president and CEO of CoStar, echoes these findings and says “Green buildings are clearly achieving higher rents and higher occupancy, they have lower operating costs, and they’re achieving higher sale prices.”

As for Turner’s “Green Building Barometer” survey, it calculates that 84% of respondents indicate that their green buildings have resulted in lower energy costs and 68% reporting lower overall operating costs. These figures are perhaps lower than one might expect from truly sustainable buildings. Likewise, nearly 65% of building owners who have built green buildings claim that their investments have already produced a positive return on investment.

The limited supply of green buildings, which although steadily increasing, still accounts for only a minor percentage of the total U.S. building stock which appears to be one of the factors for the “green” premiums, particularly since the number of green certified buildings continues to grow and the supply fails to keep pace with demand. Most developers and property owners generally agree that among the more tangible benefits of attaining a green certification for a building (e.g., LEED, Green Globes, Energy Star) is the ability to use this accomplishment as a marketing tool, and designers and contractors who have certified buildings in their portfolios typically find that they have a greater competitive marketing edge. Tenants and employees continue to show a clear preference in living and working in certifiably green buildings resulting in a greater demand and greater capability to attract quality tenants and thus higher rents. And according to McGraw Hill Construction (2012), the top two reasons for building green: client demand (35%) and market demand (33%).

1.3.1 Tax Deductions and Incentives

It was previously stated that there are numerous tax incentives in place for homeowners and businesses that purchase and install energy-efficient

equipment or make energy efficiency improvements to homes and buildings. This is in addition to the health and environmental benefits of living and working in a green building. Furthermore, the federal government's offer of tax incentives is to encourage consumers and businesses to develop and adopt energy-efficient technologies and products. Today, many local and state governments, utility companies, and other entities nationwide are offering rebates, tax breaks, and other incentives to encourage the incorporation of ecofriendly elements in proposed building projects. In fact, the majority of large cities in the United States now provide financial and other incentives for building green. In some states, green or sustainable building has ceased to be an option but rather a requirement. Recent estimates show that there are in excess of 65 local governments throughout the United States that have already made a commitment to LEED standards in building construction, with some reducing the entitlement process by up to a year in addition to various tax credits. Energy costs have become a major office building expense although this can be reduced by as much as 30% and increasing even more with the development of new technologies. Moreover, the American Recovery and Reinvestment Act of 2009 extended many energy efficiency and renewable energy tax incentives originally introduced in the Energy Policy Act of 2005 (EPACT) and extended provisions in the Emergency Economic Stabilization Act of 2008. It should be noted, however, that a tax credit is generally more useful than an equivalent tax deduction because a tax credit reduces tax dollar-for-dollar, whereas a tax deduction only removes a certain percentage of the tax that is owed. Consumers should itemize all purchases on their federal income tax form to lower the total amount of tax they owe the government.

Some of the tax incentives available for Commercial Buildings under this act include (from the DOE Website):

Deduction of the Cost of Energy-Efficient Property Installed in Commercial Buildings

A tax deduction of up to \$1.80 persquare foot is available for buildings that save at least 50% of the heating and cooling energy of a building that meets ASHRAE Standard 90.1–2001. Partial deductions of up to \$.60 per square foot can be taken for measures affecting: the building envelope, lighting, or heating and cooling systems. This act extends the deduction through December 31, 2013.

Buildings must be within the scope of ASHRAE Standard 90.1–2001 including addenda 90.1a–2003, 90.1b–2002, 90.1c–2002, 90.1d–2002, and 90.1k–2002 (in effect as of April 2, 2003) and within the control of the

building designer. Retrofit of existing buildings is also eligible for the tax deduction.

Extension of Energy Investment Tax Credits

The 30% investment tax credits (ITCs) for solar energy and qualified fuel cell properties are extended to January 1, 2017. The 30% ITC now also applies to qualified small wind energy property. The cap for qualified fuel cells increased to \$1500 per half kilowatt of capacity. Finally, a new 10% ITC is available for combined heat and power systems and geothermal heat pumps.

Accelerated Depreciation for Smart Meters and Smart Grid Systems

Currently, taxpayers generally recover the cost of smart electric meters and smart electric grid equipment over a 20-year period. This act allows taxpayers to recover the cost of this property over a 10-year period, unless the property already qualifies for a shorter recovery schedule.

On the DOE website, you can also find information about the tax deductions available for relating the purchase and installation of energy-efficient products and the construction of new energy-efficient homes. The American Recovery and Reinvestment Act of 2009 offers tax credits for residential energy efficiency measures and renewable energy systems (Note: Recipient reporting for Recovery Act awards was repealed by Congress on February 1, 2014). Here too, many of these credits were originally introduced in the Energy Policy Act of 2005 (EPACT) and amended in the Emergency Economic Stabilization Act of 2008 (P.L. 110-343).

Tax incentives available for Residential Buildings under this act include (source: DOE website):

Energy Efficiency Tax Credits for Existing Homes

Homeowners are eligible for a tax credit of 30% of the cost for improvements to windows, roofing, insulation, and heating and cooling equipment. These improvements must be placed in service from January 1, 2009 through December 31, 2010 (i.e., now expired), and there is a limit of \$1500 for all products. Improvements made in 2008 are not eligible for a tax credit. A number of tax credits for residential energy efficiency have been renewed. These tax credits are offered for purchases made in 2016, as well as backdated purchases made in 2015.

See the ENERGYSTAR website: www.energystar.gov/index.cfm?c=tax_credits.tx_index for a detailed listing of eligible improvements.

Renewable Energy Tax Credits for Existing or New Homes

Homeowners can receive a tax credit of 30% of the cost of the following renewable energy technologies with no upper limit: geothermal heat pumps, photovoltaic systems, solar water heaters, and small wind energy systems. Fuel

cells are also eligible for a tax credit with a cap. These must be placed in service by December 31, 2016 (See the ENERGY STAR website for detailed information). The Internal Revenue Service also offers information on these tax incentives, e.g., the Tax Incentives Assistance Project (TIAP) offers a flyer with more information about these tax credits. TIAP is sponsored by a coalition of public interest nonprofit groups, government agencies, and other organizations in the energy efficiency field. The program is essentially designed to give consumers and businesses information they need to make use of the federal income tax incentives for energy-efficient products and technologies passed by Congress as part of the Energy Policy Act of 2005 and which was subsequently amended on a number of occasions. It is important for readers to visit the relevant websites for the latest updates and incentive programs will change from time to time. Moreover, it is always wise to consult a tax professional on questions for specific situations, particularly since funding availability and eligibility requirements are continuously evolving and changing.

In California, for example, there is increasing evidence that the state's homebuyer tax credit which was enacted at the beginning of 2009 helped to generate new home sales, and in turn, job-generating home construction. Various links to funding sources for green building that are available to homeowners, industry, government organizations, and nonprofits in the form of grants, tax credits, loans, and other sources can readily be found on the U.S. Environmental Protection Agency website (www.epa.gov). Likewise, the Database of State Incentives for Renewables & Efficiency (DSIRE) which is a nonprofit project funded by the U.S. Department of Energy through the North Carolina Solar Center and the Interstate Renewable Energy Council, also contains on its website (www.dsireusa.org/) much information regarding local, state, federal, and utility incentives available for switching to renewable or efficient energy use. Other ways to attain federal tax credits include the use of energy-efficient products such as those proposed by the U.S. government's ENERGY STAR program (www.energystar.gov/). Energy savings must be calculated using qualified computer software approved by the IRS. The DOE provides a list of qualified software programs that commercial building owners can use to calculate energy and power cost savings that meet federal tax incentive requirements. As previously mentioned, the federal Energy Policy Act of 2005 established a tax deduction for energy-efficient commercial buildings applicable to qualifying systems and buildings which were placed in service from January 1, 2006, through December 31, 2007. This deduction was later extended several times and is now set to expire at the end of 2016.

1.3.2 Green Building Programs

According to an AIA study of Green Building Programs in our nation's communities, "The Local Leaders Report" scrutinizes the current state of green building laws in American cities as of 2007. The report states that, "Since 2003 the number of cities with green building programs has increased greater than 400%, due to a concerted effort by local political leaders, officials, architects and others within the design/building industry, and grassroots support. The primary goal of this analysis is to provide a tool for communities as well as other levels of government that seek to design green building programs in the future. It is based on research conducted by the AIA on all American cities with a population greater than 50,000 (661 communities) to spotlight the growth and effectiveness of green building policies."

Research also shows that cities throughout the United States are now supporting the use of various external green building programs. An excellent example of this is the City of Seattle which is one of the top cities in the nation for LEED facilities as well as being the largest single owners of LEED facilities in the world. This achievement was spurred by the City's adoption of the Sustainable Building Policy as early as 2000. And in 2000, Seattle broke some major ground by requiring city buildings be LEED Silver. Seattle's Green Building Policy to achieve a LEED Silver rating, applies to all new City-funded projects and renovations which contain in excess of 5000 square feet of occupied space. This policy affects all city departments that are involved with construction, including the Department http://www.seattle.gov/dpd/cms/groups/pan/@pan/@sustainableblding/documents/web_informational/dpds_007262.pdf of Planning and Development (DPD) is now the Seattle Department of Construction & Inspections which monitors implementation of the policy. Francesca Lyman of MSNBC's award-winning "Your Environment" column says that Seattle leads the nation's cities in LEED-certified buildings.

The City of Seattle currently promotes a number of green building programs such as the following:

- **Built Green:** This is an environmentally friendly, nonprofit, residential building program of the Master Builders Association of King and Snohomish Counties, developed in partnership with King County, Snohomish County, and other local environmental groups in Washington State. The Built Green programs are: New Home Building, Remodeling, and Multifamily Development and Communities.

- **Energy Star Homes:** A program for new homes that was created by the U.S. EPA and U.S. Department of Energy. Seattle witnessed a total of 5995 ENERGY STAR qualified homes built to date, whereas the State of Washington witnessed a total of 14,673 ENERGY STAR qualified homes built to date.
- **LEED for Homes:** Recently created residential rating system by the USGBC. The USGBC says that “LEED for Homes is a consensus-developed, third party-verified, voluntary rating system which promotes the design and construction of high-performance green homes.” For example, the City of Cincinnati currently offers a sizable tax incentive for new and renovated homes that are certified under the USGBC’s LEED green building rating system. The local Cincinnati chapter of the National Association of Home Builders is requesting their organization’s residential green building rating system, known as the National Green Building Standard (NGBS), to be adopted for the same tax incentive.
- **Multifamily:** Includes apartments, townhomes, and condominiums. Incentives are offered for building efficiency, renewable energy (visit: www.seattle.gov/dpd/greenbuilding for more details).

Another city deserving special mention is Nashville, Tennessee. For many years, Nashville has been known as the country music capital of the world. It is now also being acknowledged for its innovative community planning and sustainability efforts. In fact, in recent years the city has started to assert itself as a green building leader in the southeast by passing a green building law, working together with the state on sustainability efforts and helping to revitalize an aging community into a green community. Indeed, the city’s sustainability efforts provide a model of leadership for Tennessee and the wider southeast and some green proponents are seeking to make Nashville the “greenest city” in the south. Nashville now requires LEED certification for city owned buildings, so that all new and renovated structures meet green standards. Likewise, municipal facilities costing more than \$2 million or are in excess of 5000 square feet of occupied space must seek LEED Silver certification.

In addition to the Cities of Seattle and Nashville, there are many other cities in the United States that promote green building programs such as Honolulu (Hawaii), New York (New York), Phoenix (Arizona), Fremont (California), San Francisco (California), City of San José (California), Anchorage (Alaska), Minneapolis (Minnesota), Portland (Oregon), Pittsburgh (Pennsylvania), Virginia Beach (Virginia), Washington (District of Columbia), and many others.

1.3.3 Defining Sustainable Communities

The interest in sustainability and sustainable communities arose out of a desire to increase quality of life and opportunities that economic development can bring, but in a manner that preserves the environment for present and future generations. However, the concept of sustainable communities remains somewhat elusive, perhaps even complicated, and to offer a precise definition may vary from source to source. Community planners around the country have started to formulate a perception or vision of how http://www.seattle.gov/dpd/cms/groups/pan/@pan/@sustainableblding/documents/web_informational/dpds_007254.pdf such a community will grow to embrace the sustainability of its citizens' core values which include: the community, social equity, economic prosperity, environmental stewardship, security, and opportunity.

Since LEED and sustainability has become part of the mainstream in the United States, numerous cities have commenced adopting an all-inclusive plan that incorporates goals and policies designed to help guide development toward a more sustainable and environmental friendly future. This new forward-looking "green urbanism" desires to apply leading edge tools, models, strategies, and technologies to encourage cities into achieving eco-friendly sustainability goals and policies. The application of an integrated, whole-systems design approach to the planning of communities or neighborhoods puts the city in a stronger position to achieve increased environmental protection levels. Among the other compelling inducements for building owners and property developers to invest in green buildings, is the LEED certification program which includes the financial benefits of operating a more efficient and less expensive facility. The adherence to LEED guidelines will go a long way to ensuring that the facilities are designed, constructed, and operated more effectively, mainly because LEED would prefer project teams to concentrate on operating life cycle costs, rather than initial construction costs.

As previously mentioned, many states are now offering various incentives in the form of tax benefits for green building and LEED compliance. An excellent example of this is the State of New York, where Governor George Pataki in May 2001, signed into law the nation's first Green Building Tax Credit (GBTC) program. This is a 25 million dollar income tax credit created to promote the funding of concepts and ideas that encourage green building practices, particularly owners and tenants of buildings that meet specific criteria regarding energy, IAQ, water conservation, materials, commissioning, appliance, and size criteria as set out in the State regulations, maintained by the

NYS Department of Environmental Conservation. This and other programs led to the building of the first high-rise green office building in the United States as well as the first high-rise green residential building in the United States. Governor Pataki also established New York's leading brownfield program encouraging increased development in cities across the state by creating a \$200 million fund to support the redevelopment of contaminated sites and instituting a \$135 million tax credit program to stimulate public-private investment in brownfields. And after several failed attempts over recent years, the New York State Legislature and Gov. Andrew Cuomo were able to reach agreement as part of the 2015-16 state budget on extensive amendments to the New York State Brownfield Cleanup Program (BCP). This achievement is very significant in light of the scheduled expiration of tax credits under the existing program on December 31, 2015.

What is unusual is that until recently, no single organization had the vision and foresight to move toward bringing green construction to the American residential market. Any residential green programs that did previously exist were typically sponsored by local homebuilder associations (HBAs), non-profit organizations, and municipalities. Since this situation was unacceptable and unlikely to last, the National Association of Home Builders (NAHB) and the NAHB Research Center (NAHB RC) took preemptive action and produced the Model Green Home Building Guidelines and several other utility programs. But while these programs may have provided many of the solutions relating to the nation's residential building market, with respect to commercial construction, LEED was until recently the only viable program available. However, this has recently changed and many states such as the State of Oregon, for example, now stipulate that, "The building must meet an established standard set by the USGBC's LEED *or be rated by a comparable program approved by the Oregon Department of Energy.*" Likewise, in early 2007, N.Y.C. adopted broad sustainable rules for school construction; the School Construction Authority's (SCA) adopted a new Green Schools Rating System, giving the SCA a robust LEED equivalent standard and new green guidelines which were a sweeping redefinition of the rules that immediately raised the bar for future construction projects even higher than required by the new law. New York City has a number of green building laws and regulations, as well as a green building policy for schools. The Green Schools Guide was developed primarily to achieve compliance with Local Law 86 of 2005, known as New York City's Green Building Law, which was enacted by the City Council and signed into law by New York's Mayor Bloomberg. This law established a set of sustainable/green standards for public design and construction projects and

makes NYC one of the first and largest school districts in the nation to have sustainable guidelines stipulated by law. Local Law 86 (LL86) requires many capital projects that involve building construction and receive city funds, to be constructed in accordance with the standards of the national LEED, a green building rating system developed by the USGBC.

The NYC Green Schools Guide was released in 2007 and updated in 2009. This Guide focuses primarily on addressing IAQ, including addressing indoor air contaminants, such as hazardous chemicals of concern associated with PVC such as phthalates. The Guide states that schools should: “Reduce the quantity of indoor air contaminants that are odorous, irritating and/or harmful to the comfort and well being of installers and occupants. This credit is required for all projects” and “Reduce exposure of building occupants to potentially hazardous particulates and chemical pollutants. This credit is required for all projects.” In this respect, Philadelphia has recently enacted a Green Roofs Tax Credit for costs incurred by installing a roof that supports living vegetation. Likewise, Philadelphia has proposed a sustainable zoning ordinance mandating the incorporation of green roofs for buildings that occupy a minimum of 90,000 square feet (Fig. 1.2 www.facilities.upen.edu).



Figure 1.2 One of two University of Pennsylvania building projects that received LEED Gold certification by the U.S. Green Building Council (USGBC): Wharton School’s Steinberg-Dietrich Hall West Tower Entrance addition was opened in early 2013. The project was designed by Kling Stubbins and was originally built to achieve LEED Silver but exceeded that in its use of green features, having green roofs that manage stormwater runoff and reduce cooling loads and heat island effects, which utilize high-performance building materials with high-efficiency mechanical, lighting, and ventilation systems.

Of note, competition on a national scale to the LEED program in the United States came from Canada in the form of the Green Globes system. This provided a green management tool that includes an assessment protocol, rating system, and guide for integrating environmentally friendly design into commercial buildings. Green Globes hopes to offer the U.S. commercial construction industry a simpler, less expensive method for assessing and rating a building's environmental performance. Green Globes is a web-based auditing tool that was developed by a Toronto-based environmental consultant, Energy and Environment Canada. The system's greatest strength is purported to be its rapid and economical method for assessing and rating the environmental performance of new and existing buildings. Rights to market the program in the United States were purchased by the Green Building Initiative (GBI) which has budgeted more than \$800,000 as a first step to promote national awareness of Green Globes as a viable alternative to the LEED program throughout the construction and development community and try and capture a significant percentage of its market share. Green Globes is discussed in greater detail in [Chapter 2](#) of this handbook.

California and New York's building codes are among the Nation's fore-runners in sustainable development. Since taking office, Governor Arnold Schwarzenegger has made it a priority to develop a self-sustaining solar industry for California, and the solar initiatives he introduced (e.g. the Million Solar Roofs Initiative), included \$2.9 billion in incentives to homeowners and building owners who install solar electric systems and were pivotal in motivating and creating a solar industry in the state and which has now become the nation's largest market. On December 14, 2004, Governor Schwarzenegger signed Executive Order S-20-04, which requires the design, construction, and operation of all new and renovated state-owned facilities to be LEED Silver-certified. New York City's Local Law 86 (also known as "The LEED Law") took effect in January 2007. It basically requires that many of New York City's new municipal buildings, as well as additions and renovations to its existing municipal buildings, achieve certain standards of sustainability that would meet various LEED criteria. Mayor Michael Bloomberg also announced his Greener, Greater Buildings Plan in 2009 in which he set a target of 30% reduction of greenhouse gas emissions by 2017. In 2007, New Mexico passed its own major green building tax credit, and Oregon followed by passing a 35% tax credit for the employment of solar energy systems. These numerous tax incentives have spurred green building tenant attraction and retention to continue to grow and become stronger, thereby making a green building a sound investment. With regard

to reconstruction projects, building teams seeking to attain LEED Gold and Platinum certifications for their projects need to be resourceful to preserve cost premiums to a minimum. The principal obstacles are often optimizing daylighting and thermal performance, but even this can be overcome through well-conceived planning and design. According to THA Architects' Keltner, "I would make the bold statement that doing a (reconstructed) LEED-certified building doesn't cost you a nickel more than what it would be to do a standard building, if you are smart about what you are doing," "Furthermore, if you want to go to high levels of LEED certification, you can get really far with an added 5%."

1.3.4 Potential Risks of Building Green

The recent release by the AIA of six new contract documents that address the distinctive roles, risks, and opportunities we come across in Green building and generate a resolve in considering how best to mitigate risk in Green building. Risk mitigation is extremely important to all in the field of Green building, not only builders and owners of Green buildings, but also architects/designers, engineers, LEED consultants, building contractors, material suppliers, landlords, tenants, financiers realtors, and others, all who are involved with new construction or renovation of existing buildings.

Judah Lifschitz, author and copresident of Shapiro, Lifschitz & Schram, P.C., says, "The potential liability associated with taking on a green project without proper preparation is huge. Potential causes of legal action include claims for misrepresentation, fraud, negligence, negligence per se, and breach of contract. Some factors that will likely contribute to an increase in green building litigation include: (i) the volume of inexperienced parties attempting to build green; (ii) a lack of understanding and defining the term "green"; (iii) a lack of understanding of the LEED certification requirements; (iv) unintentionally guaranteeing an outcome that does not occur; and (v) failing to draft green building contracts to appropriately account for the unique risks inherent in green building projects. Thus, it is essential that before undertaking to work on a green project, you think through all aspects of the project and fully understand what a green building project constitutes and requires." Lifschitz also advises against promising more than can be delivered, and that if stakeholders are "to avoid the prospect of costly claims and litigation, green-project participants must be proactive at the outset of a project and pay careful attention to potential pitfalls when drafting and negotiating contract documents."

Green litigation and liability issues are discussed in greater detail in [Chapter 16](#).



1.4 ESTABLISHING MEASURABLE GREEN CRITERIA

The green movement continues to surge in strength and vitality, creating an urgent need to establish measurable green criteria. Rating systems in the United States and globally like LEED, BREEAM, and Green Globes are making a serious attempt to define the qualitative and/or quantitative measures of sustainability and the data needed to implement and assess these measures. These efforts are of the utmost importance because they assist us to determine if a building is having the impact on human health and the environment its designers intended and the estimated cost or saving of this achievement.

An early recognition of the urgent need to address sustainability problems facing the planet and the necessity for establishing measurable green criteria to facilitate this, was evidenced by the creation of the World Commission on Environment and Development (WCED) in December 1983 by the United Nations with the main purpose of addressing growing concerns “about the accelerating deterioration of the human environment and natural resources and the consequences of that deterioration for economic and social development.” The establishment of the WCED commission is a clear recognition by the UN General Assembly that the environmental problems we face are global in nature. The UN determined that it was in the best interest of all nations to establish common policies for sustainable development (Report of the World Commission on Environment and Development: Our Common Future—<http://www.un-documents.net/wced-ocf.htm>). Following the formation of the WCED, came the Brundtland Commission in 1987 which produced the Brundtland Report (also known as *Our Common Future*) in August of the same year. The significance of the report is that it alerted the world to the urgency of making progress toward economic development that could be sustained without depleting natural resources or harming the environment. The report highlighted three essential components to achieve sustainable development: (1) environmental protection, (2) economic growth, and (3) social equity. Some have found the findings of this report rather troubling; it states among other things:

“The ‘greenhouse effect,’ one such threat to life support systems, springs directly from increased resource use ([Fig. 1.3](#)). The burning of fossil fuels and the cutting and burning of forests release carbon dioxide (CO₂).

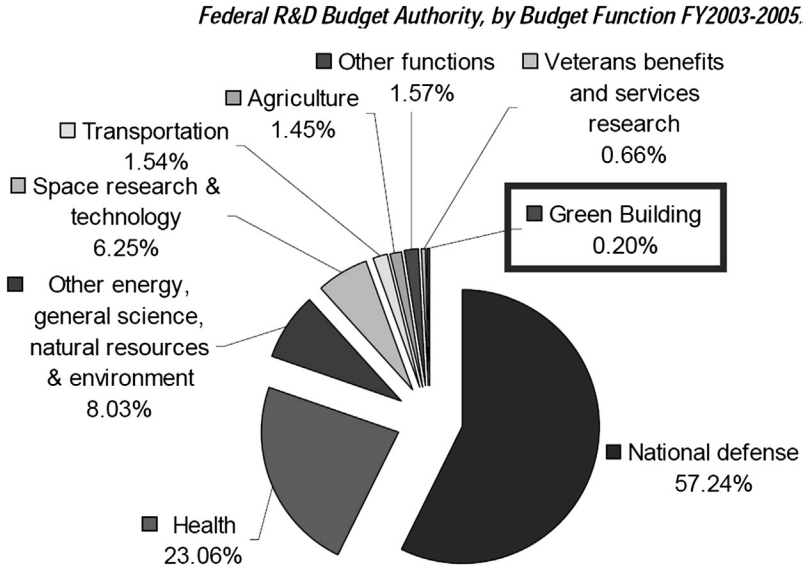

Figure 1.3 The human activities that cause climate change: Pie chart showing global anthropogenic greenhouse gas emissions broken down into eight different sectors for the year 2000. The three gases most responsible for warming are naturally occurring gases and a group of man-made chemicals. The natural gases are carbon dioxide (CO₂), methane (CH₄), and nitrous oxide (N₂O). The manufactured chemicals are collectively called the halocarbons and include chlorofluorocarbons (CFCs), hydrofluorocarbons (HFCs), perfluorocarbons (PFCs), and others. Concentrations of these greenhouse gases have increased over time and human activity may be increasing the greenhouse effect. Credit: Wikipedia File: Greenhouse Gas by Sector.png.

The accumulation in the atmosphere of CO₂ and certain other gases traps solar radiation near the earth's surface, causing global warming. This could cause sea level rises over the next 45 years large enough to inundate many low lying coastal cities and river deltas. It could also drastically upset national and international agricultural production and trade systems.

Another threat arises from the depletion of the atmospheric ozone layer by gases released during the production of foam and the use of refrigerants and aerosols. A substantial loss of such ozone could have catastrophic effects on human and livestock health and on some life forms at the base of the marine food chain. The 1986 discovery of a hole in the ozone layer above the Antarctic suggests the possibility of a more rapid depletion than previously suspected."

The Report goes on to say, "A variety of air pollutants are killing trees and lakes and damaging buildings and cultural treasures, close to and

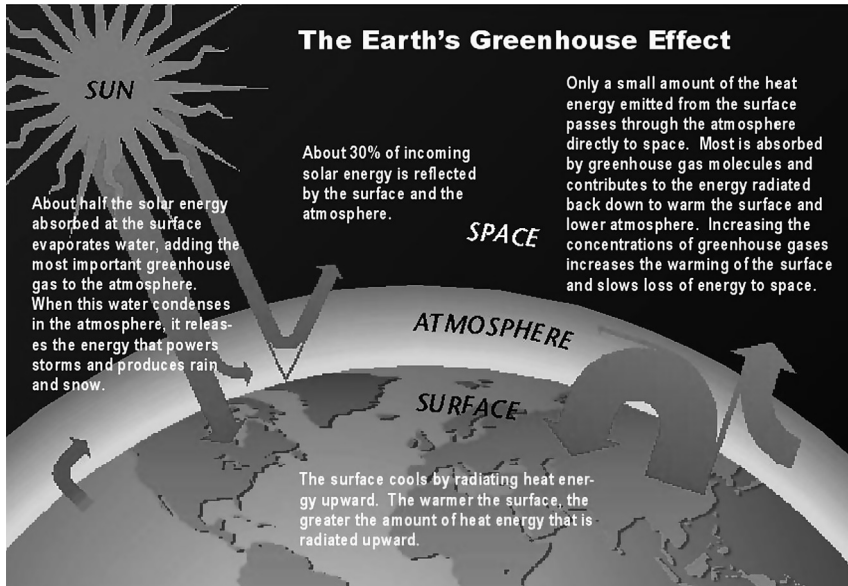

Figure 1.4 The earth's greenhouse effect. Greenhouse gases are generally gases that trap heat in the atmosphere. Some greenhouse gases such as carbon dioxide occur naturally and are emitted to the atmosphere through natural processes and human activities. Other greenhouse gases (e.g., fluorinated gases) are produced and emitted solely through human activities. The main greenhouse gases that enter the atmosphere because of human activities are: carbon dioxide (CO_2), methane (CH_4), nitrous oxide (N_2O), fluorinated gases (hydrofluorocarbons, perfluorocarbons, and sulfur hexafluoride).

sometimes thousands of miles from points of emission. The acidification of the environment threatens large areas of Europe and North America. Central Europe is currently receiving more than 1g of sulfur on every square meter of ground each year. The loss of forests could bring in its wake disastrous erosion, siltation, floods, and local climatic change. Air pollution damage is also becoming evident in some newly industrialized countries.” **Fig. 1.4** is a graphic illustration of the greenhouse effect.

When trying to establish green measuring and performance criteria, we are immediately faced with several significant challenges—both conceptual and practical. On the conceptual side, we are challenged with the need to determine precisely what our understanding of “performance” is. For example, “Performance” can be understood to mean: Does the building, as built, exhibit or embrace characteristics that are green or sustainable? It can also mean: Are the building upgrades, renovations, and reconfigurations

sustainable? In some cases, green criteria is measured by the environmental results and consequences of sustainable strategies, in terms of resource consumption and environmental impacts, and in others, it is measured by the ultimate savings and costs realized from a sustainable building.

As for the practical challenges, these mainly revolve around actual versus modeled performance. But while actual performance data are obviously more preferable, it may not always be easy to obtain, in which case one is forced to use models or estimations. Where models are necessary, it is preferable when possible to use any relevant existing data available, as this better reflects operating performance as opposed to design performance. A typical example of difficulty in obtaining relevant data to support performance is on campuses where buildings are not separately metered for energy or water use. This means that extra individual effort may be required to gather the needed data. But even when measured data are available, there still remains the question of quality and reliability of the data. Thus, to be really useful, we need to apply benchmarks for comparison to determine the level of performance and compare it to a typical well-documented building in a similar climate, with the same occupancies. Benchmarks can be a building's performance measured over time, or based on external yardsticks such as LEED, Green Globes, BREEAM, EnergyStar, the European Passivhaus, or other acceptable organizations.

In an article entitled, *Measuring Performance of Sustainable Buildings*, Joel Todd, Environmental Consultant and Kim Fowler, Senior Research Engineer, Pacific Northwest National Laboratory, says, "In recent years, building owners and designers, researchers, and others have begun performing studies related to the costs and benefits of sustainable design. Some of these studies attempt to address the full impact of sustainable design, while others emphasize the economic aspects, the environmental impacts, and the social aspects separately. Other differences in the studies include whether or not the data is measured, modeled, or some combination of both, whether the information is based on a single building or multiple buildings and the differences in how the baseline or benchmark is being used." Some of these studies include:

- The Costs and Financial Benefits of Green Buildings: A Report to California's Sustainable Building Task Force by G. Kats et al (2003)
- The Business Case for Sustainable Design in Federal Facilities by the U.S. Department of Energy, Federal Energy Management Program (FEMP).
- LEED Cost Study and LEED Applications Guide by Steven Winter Associates, Inc. for U.S. General Services Administration.
- The Human Factors of Sustainable Building Design: Post-Occupancy Evaluation of the Philip Merrill Environmental Center, Annapolis, MD

by Judith Heerwagen and Leah Zagreus for the U.S. Department of Energy (2005).

- Life-Cycle Cost Analysis (LCCA) by Sieglinde Fuller. National Institute of Standards and Technology, in WBDG. Updated 2008.
- 2007 The Cost of Green Revisited, Lisa Fay Matthiessen and Peter Morris, Davis Langdon, 2007.
- Measuring performance of sustainable buildings. JA Todd, KM Fowler—Pacific Northwest National laboratory, 2010—wbdg.org.

What is common to most assessment schemes essentially is the concept of looking at the complete building, evaluating impacts in various categories then weighting the scores in some way, tallying them up, and giving an overall score. Important categories to be considered typically include energy, water use, waste, health, materials impact, and future adaptableness. But condensing the performance into a single score is not a simple task and necessitates having the comparative relevance and importance of the various issues to be addressed by apportioning more points to the more important sections. Energy, for example, is a key criterion and is therefore typically given greater weighting than other criteria.

It is problematic that while we witnessed a substantial building boom in recent years, it was often underpinned by inferior design and construction strategies including highly inefficient HVAC systems, thus placing buildings at the top of the list of contributors to global warming. Federal and private organizations are making serious attempts to address these problems with some success, and due partly to these efforts we are now witnessing a surge of interest in green concepts and sustainability. Many developers and project owners have become aware of the numerous benefits of incorporating green strategies and are increasingly aspiring to achieve green certification for their buildings, particularly LEED certification. The principal objectives of the green building rating systems are essentially to create incentives to produce high-performance buildings and to increase demand for sustainable construction. Green buildings have been shown to be economically viable, ecologically benign and whose operation and maintenance have proven over the long term to be sustainable and very viable.

This encouraged the collaboration of the Partnership for Achieving Construction Excellence and the Pentagon Renovation and Construction Program Office who together recently issued a Field Guide for Sustainable Construction which consists of 10 chapters:

Chapter 1: Procurement – Specific procurement strategies to ensure sustainable construction requirements are addressed.

Chapter 2: Site/Environment – Methods to reduce the environmental impact of construction on the project site and surrounding environment are identified.

Chapter 3: Material Selection – Identifies environmentally friendly building materials as well as harmful and toxic materials that should be avoided.

Chapter 4: Waste Prevention – Methods to reduce and eliminate waste on construction projects are identified.

Chapter 5: Recycling – Identifies materials to recycle at each phase of construction and methods to support the onsite recycling effort.

Chapter 6: Energy – Methods to ensure and improve the building's energy performance, reduce energy consumed during construction, and identify opportunities to use renewable energy sources.

Chapter 7: Building and Material Reuse – Identifies reusable materials and methods to facilitate the future reuse of a facility, systems, equipment, products and materials.

Chapter 8: Construction Technologies – Identifies technologies which can be used during construction to improve efficiency and reduce waste (especially paper).

Chapter 9: Health and Safety – Methods to improve the quality of life for construction workers are identified.

Chapter 10: Indoor Environmental Quality – Methods to ensure indoor environmental quality measures during construction are managed and executed properly.

The object of the Field Guide is to providing guidance and educating construction field workers, as well as supervisors and managers and other stakeholders to making appropriate decisions that can help the project team to meet sustainable project goals. Most of the topics discussed in the Guide are incorporated in the LEED and other rating systems.

Additionally, there are a number of other sustainability programs that outline important green criteria. The DOE, for example, has an Environmental Protection Program, the goals and objectives of which are “to implement sound stewardship practices that are protective of the air, water, land, and other natural and cultural resources impacted by DOE operations and by which DOE cost effectively meets or exceeds compliance with applicable environmental; public health; and resource protection laws, regulations, and DOE requirements. This objective must be accomplished by implementing Environmental Management Systems (EMSs) at DOE sites. An EMS is a continuing cycle of planning, implementing, evaluating, and improving processes and actions undertaken to achieve environmental goals.”

Architects, designers, property developers, contractors, and other stakeholders must have a clear understanding of the different certification programs that are currently available, and why certification is a necessary requirement if property owners want to remain competitive in an increasingly green market. Certification implies independent verification that a building has met accepted guidelines in these areas, as outlined, for example, in the LEED Green Building Rating System. LEED certification of a project has become a recognized testimonial to its quality and environmental stewardship, especially since the LEED green building rating system has become widely accepted by public and private owners—not only in the United States but in many countries around the world and continues to increase in popularity.

Due to the major inroads into the mainstream design and construction industry by the LEED rating system, contractors and property developers are realizing that it is in their best interest to contribute toward a project's success in achieving green objectives. This is not difficult to achieve once the LEED process is understood and its specific role in achieving LEED credits, followed by through early involvement (preferably from the planning phase) and participation throughout the various project phases by implementing a team approach in an integrated design process. The application of measurable benchmarks is necessary to enable verification and confirm a building's satisfactory performance. One must point out here that ASHRAE puts the responsibility of defining design intent requirements squarely on the shoulders of the project owner. Normally, in the practice of architecture and engineering for building design, the owner hires an architect and/or engineer to develop the design intent in the design phase of the project. But to do this, it is imperative to have in place all information necessary to accomplish the design intent. Otherwise, it would be difficult if not impossible to correctly measure a building or project's performance without the necessary information being made available regarding the criteria upon which the project's design and execution was based. This requires that a project's plans and specifications, etc. are prepared in a manner that can provide measurable results, without which it would not be possible to make a meaningful or credible evaluation of a project to determine if it has met the specified objectives and original design intent of the owner. Likewise, before measurable sustainable criteria can be established, it is necessary to first agree precisely what is understood by "green construction" and to clearly articulate specifically what the finished product is to consist of. This is why in many building construction projects, points of dispute arise due to these misunderstandings of how a building, product, or system, is evaluated

prior to, during, and after construction. Where disputes cannot be resolved through standard meeting minutes or interpretation (RFIs), the parties then end up going to mediation, arbitration, or trial. Below is a useful table that highlights the responsibilities and decision making parties for each credit in the LEED Certification Process (Fig. 1.5).

The USGBC currently promotes its LEED rating system by emphasizing the simplicity of the system in addition to its other benefits. But the uniqueness of the LEED certification system is that it typically mandates performance over process. Moreover, the USGBC through the application of its widely circulated and recently updated LEED v4 scoring system and other efforts has compelled many contractors and their subcontractors to

Decision Makers Table & LEED Credit Responsible Parties							
Credit	Decision Makers			Credit	Decision Makers		
Sustainable Sites				Materials & Resources			
SS P1		Contractor	Civil Engineer	MR P1	Owner		Architect
SS 1	Owner			MR 1.1	Owner	Contractor	Architect
SS 2	Owner		LEED AP	MR 1.2	Owner	Contractor	Architect
SS 3	Owner			MR 1.3		Contractor	Architect
SS 4.1	Owner			MR 2.1		Contractor	
SS 4.2			LEED AP & Architect	MR 2.2		Contractor	
SS 4.3	Owner			MR 3.1		Contractor	Architect
SS 4.4	Owner		Civil Engineer	MR 3.2		Contractor	Architect
SS 5.1	Owner	Contractor	Civil Engineer	MR 4.1		Contractor	Architect
SS 5.2	Owner		Civil Engineer	MR 4.2		Contractor	Architect
SS 6.1			Civil Engineer	MR 5.1		Contractor	Architect
SS 6.2			Civil Engineer	MR 5.2		Contractor	Architect
SS 7.1		Contractor	LEED AP/Land/Arch/Civil	MR 6		Contractor	Architect
SS 7.2		Contractor	LEED AP	MR 7		Contractor	Architect
SS8			LEED & Lighting Dsgnr.	Indoor Environmental Air Quality			
Water Efficiency				EQ P1			Mechanical Engineer
WE 1.1			Landscape Architect	EQ P2	Owner		
WE 1.2	Owner		Landscape Architect	EQ 1			Mechanical Engineer
WE 2			Mechanical Engineer	EQ 2			Mechanical Engineer
WE 3.1			Mechanical Engineer	EQ 3.1		Contractor	
WE 3.2			Mechanical Engineer	EQ 3.2		Contractor	
Earth & Atmosphere				EQ 4.1		Contractor	Architect
EA P1	Owner	Contractor	Commissioning Auth.	EQ 4.2		Contractor	Architect
EA P2			Mechanical Engineer	EQ 4.3			Architect
EA P3	Owner		Mechanical Engineer	EQ 4.4		Contractor	Architect
EA 1			Mechanical Engineer	EQ 5			LEED AP
EA 2			Mechanical Engineer	EQ 6.1			Mechanical Engineer
EA 3	Owner	Contractor	Commissioning Auth.	EQ 6.2			Mechanical Engineer
EA 4			Mechanical Engineer	EQ 7.1			Mechanical Engineer
EA 5			Mech. Eng & Facility Eng.	EQ 7.2	Owner		Mechanical Engineer
EA 6	Owner			EQ 8.1			LEED AP & Architect
Look at each credit one by one and try and figure out why it makes sense that those are the responsible parties for that particular credit. You'll begin to notice some patterns for which trades work with which credits.				EQ 8.2			LEED AP & Architect
				Innovation in Design			
ID 1.1-1.4	Owner		Contractor				
ID 2	Owner		Contractor				LEED AP

Figure 1.5 Table highlighting decision makers and parties responsible for achieving LEED credits. Courtesy: GreenExam Academy.

change the way they operate. Perhaps, the most notable change from LEED v3 to v4 is an expansion to include rating systems for different building types and renovation types. LEED v3 has also improved its rating system by taking into account the impact of microclimate and incorporating Regional Priority to its rating system. In addition, LEED v4 will now also include Location and Linkage (transportation) and Awareness and Education. This is discussed in greater detail in [Chapter 2](#).

Other organizations such as the National Association of Home Builders (NAHB) has also put forward a set of green home building guidelines that “should be viewed as a dynamic document that will change and evolve as new information becomes available, improvements are made to existing techniques and technologies, and new research tools are developed.” The NAHB states that their Model Green Home Building Guidelines were written to help move environmentally friendly home building concepts further into the mainstream marketplace; it is one of two rating systems that make up NAHBGreen, the National Green Building Program. The NAHBGreen program allows new construction or remodel projects, driven by builders, ANSI-compliant standard, middle ground between Energy Star, and LEED more flexibility to balance cost and localization.

Unlike the LEED rating system which has four levels (certified, silver, gold, and platinum), the NAHB point program contains only three different levels of green building—Bronze, Silver, and Gold. The system is available to builders wishing to implement these guidelines to rate their projects. “At all levels, there are a minimum number of points required for each of the seven guiding principles to assure that all aspects of green building are addressed and that there is a balanced, whole-systems approach. After reaching the thresholds, an additional 100 points must be achieved by implementing any of the remaining line items.” It should be mentioned that Green Globes which is very popular in Canada uses the NAHB standards for evaluating residential buildings. Of note, the National Association of Home Builders (NAHB) has recently signed on to become one of three Greenbuild Top Tier Partners (for 2015), in addition to the AIA and Building Owners and Managers Association (BOMA) International.

While the general appearance of a green building may be similar to other conventional building forms, the conceptual design approach is fundamentally different because it revolves round a concern for the building’s potential impact on the environment. It also endeavors to extend the life span of natural resources, seeks to improve human comfort and well-being, as well as security, productivity, and energy efficiency. That sustainably designed

buildings will culminate in reduced operating costs including energy, water, and other intangible benefits is now globally recognized. In this regard, the Indian Green Building Council (IGBC) which administers the LEED India rating system highlights a number of salient Green Building attributes such as:

- Minimal disturbance to landscapes and site condition
- Use of Recycled and Environmental Friendly Building Materials
- Use of Non-Toxic and recycled/recyclable Materials
- Efficient use of Water and Water Recycling
- Use of Energy-Efficient and Eco-Friendly Equipment
- Use of Renewable Energy
- IAQ for Human Safety and Comfort
- Effective Controls and Building Management Systems

There are several other organizations like the WBDG in the United States that also set out certain objectives and principles relating to sustainable design. These are outlined below:

Objectives:

- Avoid resource depletion of energy, water, and raw material.
- Prevent environmental degradation caused by facilities and infrastructure throughout their life cycles.
- Create built environments that are livable, comfortable, safe, and productive.

Principles:

- Optimize site potential
- Optimize energy use
- Protect and conserve water
- Use environmentally preferred products
- Enhance IEQ
- Optimize operations and maintenance procedures

James Woods, previous executive director of The Building Diagnostics Research Institute (July 2002–December 2009), believes that “Building performance is a set of facts and not just promises. If the promises are achieved and verified through measurement, beneficial consequences will result and risks will be managed. However, if the promises are not achieved, adverse consequences are likely to lead to increased risks to the occupants and tenants, building owners, designers and contractors; and to the larger interests of national security and climate change.”

Alan Bilka, a sustainable design expert with ICC Technical Services, correctly points out that “Over time, more and more ‘green’ materials and

methods will appear in the coders and/or have an effect on current code text. But the implications of green and sustainable building are so wide and far reaching that their effects will most certainly not be limited to one single code or standard. On the contrary, they will affect virtually all codes and will spill beyond the codes. Some green building concepts may become hotly contested political issues in the future, possibly requiring the creation of new legislation and/or entirely new government agencies.”

The U.S. Department of Energy, National Renewable Energy Laboratory has created a High-Performance Buildings (HPB) Database to help improve building performance by showcasing examples of green buildings and providing a standardized format for displaying performance results. The DOE is also working on standardizing methods for reporting building performance by collecting relevant data on sustainable topics such as land use, energy, materials, water conservation, and IEQ. The HPB Database presents information at various levels of detail. An “Overview” level, for example, describes key information, including a project’s function and most pertinent green features. More detailed information on the project is divided into a series of modules on process, performance, and results.



1.5 EMERGING DIRECTIONS: MOVING FORWARD

We live today in both challenging and exciting times in a volatile design and construction industry. Architects, engineers, manufacturers, and the construction industry are currently facing colossal technological and institutional changes and challenges, particularly the proliferation of information technology and suitable application of sustainable practices. The 21st century architect and engineer must be able to cope with this rapid pace of technological change, an almost totally interconnected world, and multifaceted problems requiring unusual multidisciplinary solutions. Happily, sustainable design has provided us with a way to efficiently use our resources and make a minimal impact on our environment, preserving it for ourselves and future generations. But “The one constant in a volatile industry has been our ability to help construction professionals make the right decisions to drive their businesses,” and “During these tough economic times, gaining insight and intelligence about where our industry is headed and what role we will each need to play to be successful is extremely important.” said Keith Fox, former president of McGraw-Hill Construction (now Dodge Data & Analytics). Most design professionals as well as developers, contractors, manufacturers, and federal, state and local governments are enthusiastically

embracing this emerging green phenomenon. And although the world of building design and construction has over the last couple of decades been increasingly going green, it has today become an integral part of our global culture. The enthusiastic embracement of green and the increased public awareness of its benefits has brought increasing pressure on the construction industry to undergo a fundamental change in the manner it does business and executes projects. This significant development has proved to be a milestone in the construction industry. Moreover, according to a 2008 Green Building Market Barometer online survey of commercial real estate executives conducted by New York City–based Turner Construction, even the 2008 credit collapse has failed to adversely impact the desire of property developers to go green. This debunks one of the many myths that green building is a fad but rather validates the fact that it is global and here to stay. In fact, in McGraw Hill Construction's recent (2011) Construction Outlook, it predicted an increase in overall US construction starts for 2011. It predicted the level of construction starts in 2011 to advance by 8% to USD 445.5 billion, following the 2% decline predicted for 2010. Furthermore, based on the research and analysis of macro trends McGraw-Hill Construction's 2011 Construction Outlook made other significant predictions for each construction sector, as follows:

1. Single family housing in 2011 will climb 27% in dollars, corresponding to a 25% increase in the number of units to 565,000 (McGraw Hill construction basis)
2. Multifamily housing will rise 24% in dollars and 23% in units, continuing to move gradually upward
3. Commercial buildings will increase 16%, following a 3-year decline, which dropped contracting 62% in dollar terms. The level of activity expected for stores, warehouses, offices, and hotels in 2011 will still be quite weak by historical standards
4. The institutional building market will slip an additional 1% in 2011, retreating for the third straight year. The difficult fiscal climate for states and localities will continue to dampen school construction, although the healthcare facilities category should see moderate growth
5. Manufacturing buildings will increase 9% in dollars and 11% in square feet
6. Public works construction will drop 1%, given the fading benefits of the federal stimulus act for highway and bridge construction
7. Electric utilities will slide 10%, falling for the third year in a row.

However, according to Dodge Data & Analytics (formally McGraw-Hill Construction) after the steady growth in 2014, the construction industry is expected to see a strong uptick in construction starts in 2015. Dodge

forecasts that the total value of construction starts in 2015 could reach \$612 billion—up 9% from 2014. Moreover, according to Dodge, “The residential, commercial and institutional sectors, in particular, are expected to boost activity.” Dodge also estimated that 2014 will close out with \$563.9 billion in starts—a 5% increase over 2013. That tally is well above the \$550 billion total that Dodge initially forecast for the year.

Moreover, after steady growth in 2014, the construction industry is expected to see a strong uptick in construction starts in 2015, according to Dodge Data & Analytics (formally McGraw-Hill Construction). Dodge also forecasts that the total value of construction starts could reach \$612 billion in 2015—up 9% from 2014. Based on research of specific construction market sectors, the 2015 Dodge Construction Outlook details the forecast as follows:

1. “Commercial building will increase 15%, slightly faster than the 14% gain estimated for 2014. Office construction has assumed a leading role in the commercial building upturn, aided by expanding private development as well as healthy construction activity related to technology and finance firms. Hotel and warehouse construction should also strengthen, although the pickup for stores is more tenuous.
2. Institutional building will advance 9%, continuing the moderate upward trend that has been established during 2014. The educational building category is now seeing an increasing amount of K-12 school construction, aided by the financing made available by the passage of recent construction bond measures. Healthcare facilities are expected to show some improvement relative to diminished activity in 2014.
3. Single family housing will rise 15% in dollars, corresponding to an 11% increase in units to 700,000 (Dodge basis). It’s expected that access to home mortgage loans will be expanded, lifting housing demand. However, the millennial generation is only gradually making the shift toward homeownership, limiting the potential number of new homebuyers in the near term.
4. Multifamily housing will increase 9% in dollars and 7% in units to 405,000 (Dodge basis). Occupancies and rent growth continue to be supportive, although the rate of increase for construction is now decelerating as the multifamily market matures.
5. Public works construction will improve 5%, a partial rebound following the 9% decline estimated for 2014. Highway and bridge construction should stabilize, and modest gains are anticipated for environmental public works. Federal spending restraint will be offset by a greater financing role played by the states, involving higher user fees and the increased use of public-private partnerships.

6. Electric utilities will slide 9%, continuing the downward trend that has followed the exceptional volume of construction starts that was reported during 2011–12. With more projects now coming on line, capacity utilization rates will stay low, limiting the need for new construction.
7. Manufacturing plant construction will settle back 16%, following the huge increases reported during both 2013 (up 42%) and 2014 (up 57%) that reflected the start of massive chemical and energy-related projects. Next year's volume remains quite high by recent historical standards."

The public's increased environmental alertness has become an integral component of the corporate mainstream and general global awareness of human impact on the environment as well as an increase in consumer demand for sustainable products and services are creating new challenges and opportunities for businesses in all aspects of the construction-related industries. Enlightened corporations have responded to these challenges by becoming more mindful of these environmental impacts. "Green" organizations such as the USGBC and Green Globes play a pivotal role in raising corporate awareness and encouraging increased participation in the green movement. Moreover, in addition to the United States, LEED and other building rating systems can be found the world over, in countries as diverse as Britain, Mexico, Australia, Spain, Canada, India, China, United Arab Emirates, Israel, and Japan, to name but a few examples, where the green movement is well underway. What is even more profound is that green buildings are by codification, becoming the law of the land. For some organizations, this will just mean business as usual, but for others, this sudden change will be cataclysmic. The new codes will invariably mean increased expectations from designers and contractors and possibly increased litigation due to the increased standard of care.

The concept and practice of sustainability continues to have a profound impact on building construction and design and helps to fundamentally transform the building market, and change our perception of how we design, inhabit, and operate our buildings. In fact, among the primary factors that are accelerating the push toward building green include: An increased demand for green construction, particularly in the residential sector, increasing levels of government initiatives, and improvements in the quality and availability of environmentally friendly building materials. This increasing demand for sustainability has forced many businesses to seek new ways to become more sustainable, mainly by focusing their efforts on improving their buildings' energy efficiency and interior environmental air quality.

Spurred by this growing demand for building projects that employ environmentally friendly and energy-efficient materials, a strong green

movement in the construction industry has emerged. With this in mind, we witness a number of forward-looking general contracting companies such as DPR Construction, Inc. jumping on the green bandwagon and being well prepared and well placed to deliver successful green projects. According to DPR, which is an employee-owned firm, they have LEED-trained and accredited professionals in every one of their 19 national offices across the country. DPR, which boasts a resume of over \$1 billion in green building projects, claims to have trained more than 500 professionals in overall sustainability and green building in addition to all of the available LEED programs. Furthermore, 27% of DPR's professionals having acquired LEED accreditation; this is reportedly the highest percentage of LEED accredited professionals in the nation among general contractors. Their main competitors in the United States are: Skanska USA Building, Turner Construction, Clark Construction Group.

In January 2009, President Obama inherited a depressed economy, yet even with the downturn in the economy and the construction industry, the amount of "green buildings" being built in the United States is estimated to be in excess of \$10 billion. According to the Department of Commerce (2008), the construction market constituted about 13.4% of the \$13.2 trillion U.S. GDP, which includes all commercial, residential, industrial, and infrastructure construction. Commercial and residential building construction on their own accounted for about 6.1% of the GDP (source: Department of Construction—2008). Furthermore, as of 2006, the USGBC's LEED system certified 775 million sq.ft. of commercial office space as green. This represents a mere 2% of US commercial office space. However, this is expected to increase exponentially, with green buildings accounting for 5–10% of the US commercial construction market by 2010. Still, according to Howard Birnberg, executive director of the Association for Project Managers, "Whatever the condition of the economy, technology continues to advance. While it remains to be seen if Building Information Modeling (BIM) will be a game changer for the industry, the ability to integrate new technology is an expensive and endless challenge. Training of design and construction staff in new technology and important subjects such as project management has been widely neglected during the downturn. When workloads improve, many organizations will need to play catch up on their staff training."

At the annual 2010 Greenbuild Conference, the USGBC announced that it achieved a major milestone in the certification of more than one billion square feet of commercial real estate through its LEED Green Building Rating System. It further reported that another 6 billion square feet

of projects around the world are registered and seeking to achieve LEED certification. Whereas in 2015, more than 13.8 billion square feet of building space was LEED-certified (as of August, 2015).

Among the many indicators reflecting global interest in the USGBC and LEED is evidenced each year by the large attendance and number of different countries represented at Greenbuild, the USGBC's International Conference and Expo. As an example, nearly 17,500 people attended the Greenbuild 2014 conference in New Orleans, Louisiana (source: USGBC Green Building Facts), compared to only 4200 who attended the same event in Austin, TX, in 2002. The attendees at the 2014 New Orleans Greenbuild included representatives from all 50 states, over 85 countries, and 6 continents. There were also 552 exhibiting companies participating in 142,000 square feet of exhibit and display space on the trade show floor.

There growing evidence once again shows that the shift toward green construction is truly a global trend, with more countries putting more resources into improving efficiency and sustainability. In 2008, for example, the McGraw Hill "Global Green Building Trends" states that 67% of global construction firms reported that at least 16% of their projects are green buildings. And in 2013 the global green building market grew to \$260 billion, including an estimated 20% of all new U.S. commercial real estate construction. This trend is a clear signal that green construction has not only become part of the mainstream but can be expected to intensify in the future in addition to achieving a significant share of the construction industry's multi trillion dollar global market.

Europe has reportedly achieved the highest level of sustainable building activity in the international arena, with an unprecedented 44 % of European construction firms building green on at least 60% of their projects. Following, comes North America and Australia but the gaps are gradually closing. However, Asia has the greatest potential for increasing its market share, where the number of firms dedicated to green construction is projected to increase three-fold in the coming years.

It is interesting to note that although the AIA has concluded that buildings are the leading source of greenhouse gas emissions in the United States, a recent online survey conducted by Harris Interactive shows that only 4% of US adults were aware of this fact. However, the quantity and quality of much of the data that generally relate to business and the environment unfortunately remains inadequate and wanting. It is sad that some government agencies, corporations, nonprofit groups, and academic institutions, continue to maintain a lethargic approach and produce relatively

little to quantify or assess simple measures of business environmental impact. However, it must be stated that increasing interest is being observed in recent years.

For example, according to Frank Hackett, an energy conservation sales consultant for Mayer Electric Supply Co. Inc., says that one of the simplest things that a business can do to improve its efficiency and reduce costs is to update or retrofit its lighting system. Among the various examples he gives is to modify and update existing lighting fixtures to use the more energy efficient T-5 or T-8 fluorescent lamps in place of the T-12 models that are widely used. Replacement of the magnetic ballasts in the lighting can also help increase the system's energy efficiency. Recent DOE estimates show that a significant percentage of a business's normal energy bill consists of lighting costs, and being able to reduce these costs can have a favorable economic impact. Employing automatic control systems that take advantage of natural light and automatically switch off when no one is around should also be considered as an energy-saving option.

The U.S. Department of Energy (DOE), issued a recent ruling that States must now certify that their building codes meet the requirements in ASHRAE/IESNA's 2004 energy efficiency standard. The American Society of Heating, Refrigerating & Air-conditioning Engineers (ASHRAE) has moved forward in developing the nation's first standard for high-performance, green commercial buildings (Standard 189.1P). This standard requires buildings to be significantly more efficient than that required by its Standard 90.1-2007, Energy Standard for Buildings except Low-Rise Residential Buildings. The USGBC also reaffirmed its commitment to the development of Standard 189.1P, which when completed will be America's first national standard developed to be used as a green building code. Standard 189.1P is being developed as an ANSI standard, created specifically for adoption by states, localities, and other building code jurisdictions that are ready to require a minimum level of green building performance for all commercial buildings. ICC Chief Executive Officer Richard P. Weiland says that "The emergence of green building codes and standards is an important next step for the green building movement, establishing a much-needed set of baseline regulations for green buildings that is adoptable, usable, and enforceable by jurisdictions," and that "The IGCC provides a vehicle for jurisdictions to regulate green for the design and performance of new and renovated buildings in a manner that is integrated with existing codes as an overlay, allowing all new buildings to reap the rewards of improved design and construction practices."

On October 3, 2008, President Bush signed into law H.R. 1424 and extended the Energy Efficient Commercial Building Tax Deduction as part of the Emergency Economic Stabilization Act of 2008. This provides a tax deduction and is not a tax credit i.e., an amount can be subtracted from the gross taxable income and cannot be directly subtracted from tax owed. This recently created program can offer benefits to the taxpayer and be used as an incentive to assist in choosing energy-efficient building systems. Thus, GBIs were suddenly popping up on all sides of the equation.

California passed its Revised Title 24 Code in October 2005 in response to a legislative mandate to reduce California's energy consumption. The Energy Commission later adopted the 2008 Standards on April 23, 2008, and the Building Standards Commission approved them for publication on September 11, 2008. Additionally, a new law that took effect on January 1, 2009, states that owners of all nonresidential properties in California are mandated to make available to tenants, lenders, and potential buyers, the energy consumption of their buildings as part of the state's participation in the Federal ENERGY STAR program. These data will then be transmitted to the Environmental Protection Agency's ENERGY STAR Portfolio Manager who will benchmark the information under its ENERGY STAR Standards. Upon assembling this data beginning in 2010, building owners will be required to disclose the data and ratings. The compelling reasons why the Energy Commission adopted changes to the Building Energy Efficiency Standards in 2008 include:

1. To provide California with an adequate, reasonably priced, and environmentally sound supply of energy.
2. To respond to Assembly Bill 32, the Global Warming Solutions Act of 2006, mandating that California must reduce its greenhouse gas emissions to 1990 levels by 2020.
3. To pursue California energy policy that energy efficiency is the resource of first choice for meeting California's energy needs.
4. To act on the findings of California's Integrated Energy Policy Report (IEPR) that Standards are the most cost-effective means to achieve energy efficiency, expects the Building Energy Efficiency Standards to continue to be upgraded over time to reduce electricity and peak demand, and recognizes the role of the Standards in reducing energy related to meeting California's water needs and in reducing greenhouse gas emissions.

5. To meet the West Coast Governors' Global Warming Initiative commitment to include aggressive energy efficiency measures into updates of state building codes.
6. To meet the Executive Order in the GBI to improve the energy efficiency of nonresidential buildings through aggressive standards.

The majority of major cities within the United States have since initiated some form of energy efficiency standards for new construction and existing buildings. Washington State, for example, in April 2005 began requiring that all state-funded construction projects having more than 5000 square feet are to be built green. In May 2006, Seattle moved forward and approved a plan offering incentives to encourage site-appropriate packages of greening possibilities that included green roofs, exterior vertical landscaping, interior green walls, air filtration, and stormwater runoff management. Seattle can also boast of becoming the first municipality in the United States to adopt the USGBC's LEED Silver rating for its own major construction ventures.

The state which boasts the second highest number of LEED-certified buildings in the nation is Pennsylvania which currently has 83 and is just behind California. Pennsylvania now has put into place four state funds, including a \$20-million Sustainable Energy Fund that offers grants and loans for energy efficiency and renewable energy projects. The city of Philadelphia has also recently enacted a "Green Roofs Tax Credit" to encourage the installation of roofs that supports living vegetation and has also proposed a "Sustainable Zoning" ordinance that mandates buildings that occupy a minimum of 90,000 square feet or more to incorporate green roofs in their design.

In April 2007, the Baltimore City Planning Commission in Maryland voted to require developers incorporate green building standards into their projects by 2010. Boston also amended its zoning code to require all public and private development projects in excess of 50,000 square feet to be constructed to green building standards. When Washington, D.C.'s Green Building Act of 2006 went into effect in March 2007, it became the first major US city to require LEED compliance for private projects. The application of these new green building standards became mandatory in the District in 2009 for privately owned, nonresidential construction projects with 50,000 square feet or more; public projects are also now required to comply with these new standards.

The USGBC says that as of September 2010, "Various LEED initiatives including legislation, executive orders, resolutions, ordinances, policies, and

incentives are found in 45 states, including 442 localities (384 cities/towns and 58 counties), 35 state governments (including the Commonwealth of Puerto Rico), 14 federal agencies or departments, and numerous public school jurisdictions and institutions of higher education across the United States.” Furthermore, with the increasing onslaught of building green into the mainstream, it seems that soon, green or sustainable building will cease to be an option to participate in but rather a requirement to be adopted. Stacey Richardson, a product specialist with the Tremco Roofing & Building Maintenance division says, “It is the way of the future, and industry developments in new green technology will provide building owners increasing access to energy saving, environmentally friendly systems and materials. Everything from bio-based adhesives and sealants, low-VOC or recycled-content building products, to the far-reaching capabilities of nanotechnology—the movement of building ‘renewable’ and ‘energy-efficient’ will only continue to strengthen”. Even colleges and universities such as Harvard University, Pennsylvania State, the University of Florida, the University of South Carolina, the University of California—Merced, and others have jumped on the going green bandwagon.

A recent study, *Greening Buildings and Communities: Costs and Benefits*, by Landmark International that is purported to be the largest international study of its kind, and based on extensive financial and technical analysis of 150 green buildings in 33 U.S. states and in 10 countries worldwide, built from 1998 to 2008, provides one of the most detailed and reliable findings to date on the costs and financial benefits of building green. Some of the key findings outlined in the report are outlined below:

- *Most green buildings cost 0–4 percent more than conventional buildings, with the largest concentration of reported “green premiums” between 0–1 percent. Green premiums increase with the level of greenness but most LEED buildings, up through gold level, can be built for the same cost as conventional buildings. This stands in contrast to a common misperception that green buildings are much more expensive than conventional buildings.*
- *Energy savings alone make green building cost-effective. Energy savings alone outweigh the initial cost premium in most green buildings. The present value of 20 years of energy savings in a typical green office ranges from \$7/sf (certified) to \$14/sf (platinum), more than the average additional cost of \$3 to \$8 per square feet for building green.*
- *Green building design goals are associated with improved health and with enhanced student and worker performance. Health and productivity benefits remain a major motivating factor for green building owners, but are difficult to*

quantify. Occupant surveys generally demonstrate greater comfort and productivity in green buildings.

- *Green buildings create jobs by shifting spending from fossil fuel-based energy to domestic energy efficiency, construction, renewable energy and other green jobs. A typical green office creates roughly one-third of a permanent job per year, equal to \$1/sf of value in increased employment, compared to a similar non-green building.*
- *Green buildings are seeing increased market value (higher sales/rental rates, increased occupancy and lower turnover) compared to comparable conventional buildings. CoStar, for example, reports an average increased sales price from building green of more than \$20/sf providing a strong incentive to build green even for speculative builders.*
- *Roughly 50 percent of green buildings in the study's data set see the initial "green premium" paid back by energy and water savings in five years or less. Significant health and productivity benefits mean that over 90 percent of green buildings pay back an initial investment in five years or less.*
- *Green community design (e.g., LEED-ND) provides a distinct set of benefits to owners, residents and municipalities, including reduced infrastructure costs, transportation and health savings and increased property value. Green communities and neighborhoods have a greater diversity of uses, housing types, job types and transportation options and appear to better retain value in the market downturn than conventional sprawl.*
- *Annual gas savings in walkable communities can be as much as \$1000 per household. Annual health savings (from increased physical activity) can be more than \$200 per household. CO₂ emissions can be reduced by 10–25 percent.*
- *Upfront infrastructure development costs in conservation developments can be reduced by 25 percent, approximately \$10,000 per home.*
- *Religious and faith groups build green for ethical and moral reasons. Financial benefits are not the main motivating factor for many places of worship, religious educational institutions and faith-based non-profits. A survey of faith groups building green found that financial cost effectiveness of green building makes it a practical way to enact the ethical/moral imperative to care for the Earth and communities. Building green has also been found to energize and galvanize faith communities.*

Despite the fact that the USGBC, a nonprofit membership organization was founded in 1993, it was only in the last few years that it has become a significant driving force in the green building construction movement and by the end of 2015 encompassed roughly 20,000 member companies and organizations. Its important leadership role was achieved

mainly through the early development of its commercial building rating system known as the Leadership in Energy and Design (LEED). The process for earning LEED certification typically starts in the early planning stage, where the interested stakeholders make a determination to pursue certification. This is followed by registering the project and paying the required fee. Once the project is completed and commissioned and all the required numbers are handed in with supporting documentation, the project is submitted for evaluation and certification. This is discussed in greater detail in [Chapter 2](#).

It is quite evident that the USGBC has had a very significant impact on green building and has emerged as a clear leader in fostering and furthering green building efforts throughout the world. In the United States, the LEED Green Building Rating System is increasingly becoming the national standard for green building; it is also internationally recognized as a major tool for the design and construction of high-performance buildings and sustainable projects. With its eye clearly focused on the future, the USGBC has recently issued its LEED v4. The USGBC has also recently put in place a strategic plan for the period 2009–13 in which it outlines the key strategic issues that face the green building community such as:

- “Shift in emphasis from individual buildings toward the built environment and broader aspects of sustainability, including a more focused approach to social equity;
- Need for strategies to reduce contribution of the built environment to climate change;
- Rapidly increasing activity of government in green building arena;
- Lack of capacity in the building trades to meet the demand for green building;
- Lack of data on green building performance;
- Lack of education about how to manage, operate, and inhabit green buildings; and
- Increasing interest in and need for green building expertise internationally.”

One of the primary indicators reflecting international interest in the USGBC and LEED can be evidenced by the large annual attendance and the increasing number of countries represented at Greenbuild, the USGBC’s International Conference and Expo. Again, this substantial attendance reflects the international importance of the annual Greenbuild Conferences and Expos and once again shows that Greenbuild has become an important forum for international leaders in green building and in which ideas and information can be exchanged.

Of particular importance is the 2008 Greenbuild conference, because many international delegations attended including a high-level delegation from China headed by the Vice Minister of the Ministry of Construction, Mr. Qiu Baoxing. This is significant because over the past decade, China's economy has been expanding and growing at a phenomenal rate, and some forecasts predict it will become the largest economy in the world by 2020. In the wake of such growth, however, comes a series of potentially severe environmental challenges. China has been able to make substantial inroads to addressing these challenges and reversing many of these environmental trends. To further this goal, China announced the initiation of a new energy efficiency strategy, of which green building is a primary component. This was followed by the signing of a Memorandum of Understanding (MOU) between the Chinese Ministry of Construction and the USGBC, in which points of mutual interest are identifying for collaboration in the advancement of constructing environmentally responsible buildings in both the United States and China.

Project teams around the world are today applying the LEED rating system as developed in the United States. The USGBC was quick to recognize, however, that certain criteria, processes or technologies may not always be appropriate for all countries, and that successful strategies for encouraging and practicing green building will vary from one country to another, depending on local conditions, traditions, and practice. This reality was addressed by the USGBC agreeing to sanction other countries to license LEED, and allow them to adapt the rating system to their specific needs on the understanding that LEED's high standards are not compromised. Various countries worldwide have expressed an interest to being LEED licensed, and several countries like Canada and India now have their own LEED licensing programs.

On the international stage, the USGBC works through the World Green Building Council (WorldGBC) which was formed in 1999 by David Gottfried. The WorldGBC defines itself as a union of national Green Building Councils from around the world, making it the largest international organization influencing the green building marketplace. It is currently on the ground in more than 90 countries. One of WorldGBC's primary goals is to help other countries in establishing their own Councils and finding a way to work effectively with policy makers and local industry. The WorldGBC is devoted to transforming the global property industry to sustainability as its states on its website, the "WorldGBC draws on the support of its partnerships to support the work of Green Building

Councils around the world and to further drive the transition toward market transformation of the global property industry. Key partnerships have been made with private sector companies, governmental, and nongovernmental organizations, and academic institutions.” The main mission of the WorldGBC is to serve as a forum for knowledge transfer between Green Building Councils and to support and promote the individual Green Building Council members. The WorldGBC also has the mission of recognizing global green building leadership and encouraging the adoption and development of market-based environmental rating systems that meet local needs for each country. However, the WorldGBC does not promote any particular system or methodology as a global standard.

Responding to the various terrorist attacks such as on the World Trade Center in New York, in Mumbai, India, and Europe (mainly France and Belgium) many architects and building owners are now demanding that their facilities be designed to have greater blast resistance and to better withstand the effects of violent tornadoes and hurricanes, for example, by the use of blast-resistant windows with protective glazing. This is of particular importance with high-rise buildings. Federal buildings are now required to incorporate windows that provide protection against such potential threats. Likewise, there are increasing demands from both governments and the public alike, for structures to be sustainable and meet general environmental requirements.

USGBC has emerged as a driving force of an industry that is projected to contribute \$554 billion to the U.S. gross domestic product from 2009 to 2013. USGBC leads an unlikely diverse following of professional designers and engineers, builders and environmentalists, federal agencies, corporations and nonprofit organizations, as well as teachers and students. Moreover, USGBC now comprises some 80 local affiliates, 20,000 member companies and organizations, and more than 155,000 LEED Professional Credential holders. This unprecedented growth of the USGBC is further evidenced by the dramatic increase in the number of certified and registered projects since LEED was first launched in 2000. As of August 2015, there was more than 13.8 billion square feet of building space are LEED-certified. Certified projects are projects that have been completed and verified through the USGBC’s process, while registered projects are those that are still in the process of design or construction. Also, as of August 2015, there are more than 72,500 LEED building projects located in over 150 countries and territories. This makes LEED the most popular and widely used green building rating system globally. This astonishing increase in LEED project registration is very significant as it is a clear indicator of future prospects for the green industry.

Industry executives like Bob Schroeder, Industry Director (Americas) for Dow Corning's construction business, echoes this sentiment and says, "Today, sustainable design has been recognized by the industry and the public as critical factors in achieving high quality architecture and benefiting the building owners - the companies that occupy these structures and the wider community." Additionally, a substantial number of mergers and acquisitions are taking place allowing firms to reposition themselves in emerging markets and gaining added expertise while developing new relationships. Moreover even with a depressed economy, green design has become a fixture and is here to stay. It no longer suffices for owners/institutions/agencies to just talk about green. There is a strong incentive to implement elements of green design into new and existing construction projects.

While most design professionals consider great architecture to be a delicate balance of form and function, we nevertheless find high-rise buildings being constructed on a global scale with increasing ferocity, often with little concern for due diligence, the environment, or aesthetics. What is transpiring from this unusual green building upheaval, is the emergence of several interesting trends such as the building of spectacular landmarks as exemplified by the Sydney Opera House (Fig. 1.6), and Burj Dubai (Fig. 1.7) which is the highest building in the world and which was recently awarded CTBUH's Highest Award: "Global Icon". It was also awarded the "Best Tall Building" award. Bill Baker, Chief Structural Engineer for Burj Khalifa and SOM Partner says, "Burj Khalifa is a game changer. This incredible team of architects, engineers, consultants and contractors has been able to create something that goes far beyond what has been done before. We are extremely grateful to the CTBUH for creating this prize for the project and recognizing the Burj Khalifa's impact on the art of tall buildings."

The towering Burj Khalifa skyscraper is the center of a large scale, mixed-use development comprised of residential, commercial, hotel, entertainment, shopping, and leisure outlets with open green spaces, water features, pedestrian boulevards, a shopping mall, and a tourist-oriented old town. The design of the tower combines historical and cultural influences with cutting-edge technology to achieve a high-performance building. Its massing is manipulated in the vertical dimension to induce maximum vortex shedding and minimize the impact of wind on the tower's movement. Also of note, on New Year's Eve, there was a huge fire which engulfed the 63-storey Address hotel which is located near the Burj Khalifa tower, ahead of a New Year's Eve firework display.



Figure 1.6 Photo of Australia's Sydney Opera House which overlooks the harbor which is considered to be one of the most recognizable buildings in the world and has become the city's landmark. It consists of 14 freestanding sculptures of spherical roofs and sail-like shells sheathed in white ceramic tiles. The original plan to build the opera house was won in competition in 1957 by the late Danish architect John Utzon, but because his vision and design were too advanced for the architectural and engineering capabilities at the time, it was not until 1973 that the Opera House was finally opened. *Source: Best places of world.*



Figure 1.7 Illustration of Burj Khalifa, Dubai which was inaugurated on January 4, 2010. Burj Khalifa is currently the tallest skyscraper in the world in all three categories recognized by the Council on Tall Buildings and Urban Habitat (CTBUH), the world leading authority which compiles and ranks the world's tallest buildings. CTBUH ranks buildings on the basis of height to architectural top, highest occupied floor and height to tip. Burj Khalifa, was designed by the Chicago office of Skidmore, Owings & Merrill LLP (SOM) and constructed by Samsung/BESIX/Arabtec Corporation for Emaar properties, UAE. Turner Construction International was the project and construction manager. The height of the completed tower is 2717 feet (828 m) and built at a cost of about \$1.5 billion. It reportedly contains 160 habitable floors, 57 elevators, apartments, shops, swimming pools, spas, corporate suites, Italian fashion designer Giorgio Armani's 160 room hotel, and an observation platform on the 124th floor. *Source: Skidmore, Owings & Merrill.*

We often find that the main driving force behind the creation of national landmarks is basically twofold: the primary desire is to provide cities with important recognizable symbols to foster local and national pride; the second is essentially an economical one, e.g., increasing tourism.



Components of Sustainable Design and Construction



2.1 OVERVIEW

Today we are witnessing an impressive sustainability and green building boom. Most developers and the contracting industry have come to realize that green building and sustainability have become a hot selling point with home and business customers; it can add tangible value to a project for years to come, which is why an increasing number of designers, builders, and building owners are getting involved in green building practices. Specializing in green building and sustainability basically means incorporating environmentally friendly techniques and sustainable practices into a business' operations. National and local programs instigating and promoting green building are growing and reporting increasing successes, while thousands of certified green projects across the nation and internationally provide ample evidence of what sustainable building design can accomplish in terms of aesthetics, comfort, and energy and resource efficiency. It obviously helps if a business owner or one or more employees are Leadership in Energy and Environmental Design (LEED) Accredited Professionals.

Roger Woodson, a well-known author and contractor says, "In theory, you don't have to know much about construction to be a builder who subs all the work out to independent contractors, but as the general contractor it is you who will ultimately be responsible for the integrity of the work."

It is a well-known fact that buildings have an enormous impact on the environment—both during construction and through their operation. "Green/sustainable building" remains a loosely defined collection of strategies including land use, building design, construction, and operation that reduce environmental impacts. Green building practices facilitate the creation of environmentally sound and resource-efficient, high-performance buildings by employing an integrated team approach to design in which architects, engineers, builders/contractors, land planners, building owners, and operators, pool their resources to design the project.

In December 1983 the United Nations founded the World Commission on Environment and Development (WCED) with the mission of addressing growing concerns “about the accelerating deterioration of the human environment and natural resources and the consequences of that deterioration for economic and social development.” The WCED was later followed by the Brundtland Commission in 1987 which produced the Brundtland Report, whose findings were particularly troubling. Among other things, the report stated:

“The ‘greenhouse effect,’ one such threat to life support systems, springs directly from increased resource use. The burning of fossil fuels and the cutting and burning of forests release carbon dioxide (CO₂). The accumulation in the atmosphere of CO₂ and certain other gases traps solar radiation near the Earth’s surface, causing global warming. This could cause sea level rises over the next 45 years large enough to inundate many low lying coastal cities and river deltas. It could also drastically upset national and international agricultural production and trade systems.

Another threat arises from the depletion of the atmospheric ozone layer by gases released during the production of foam and the use of refrigerants and aerosols. A substantial loss of such ozone could have catastrophic effects on human and livestock health and on some life forms at the base of the marine food chain. The 1986 discovery of a hole in the ozone layer above the Antarctic suggests the possibility of a more rapid depletion than previously suspected.”

The Report goes on to say, “A variety of air pollutants are killing trees and lakes and damaging buildings and cultural treasures, close to and sometimes thousands of miles from points of emission. The acidification of the environment threatens large areas of Europe and North America. Central Europe is currently receiving more than 1 g of sulfur on every square meter of ground each year. The loss of forests could bring in its wake disastrous erosion, siltation, floods, and local climatic change. Air pollution damage is also becoming evident in some newly industrialized countries.”

The building industry in the United States is sometimes plagued by inferior design and construction strategies as well as highly inefficient HVAC systems, helping to make buildings the largest contributors to global warming. Several federal and private organizations are making continuous efforts to address these problems, and partly because of these efforts, we are now witnessing a surge of interest in green concepts and sustainability to the extent that “green” has now dashed into the mainstream of the construction industry. Most project owners are aware of the many benefits of incorporating green strategies into their projects and are now increasingly aspiring to achieve LEED certification for their buildings. There are several green building rating

systems currently being employed in the United States. They generally serve two principal functions—the promotion of high-performance buildings and the facilitation and creation of demand for sustainable construction.

Research clearly shows that green buildings are economically viable, ecologically benign and whose operation is supportable over the long term. With this in mind, the Partnership for Achieving Construction Excellence and the Pentagon Renovation and Construction Program Office recently published (June 2004) a Field Guide for Sustainable Construction to assist and educate field workers, supervisors, and managers in making decisions that help the project team meet its sustainable project goals and how to incorporate sustainable building practices into the construction process. The salient points outlined in this Guide are:

1. Procurement—Specific procurement strategies are identified and put in place to ensure sustainable construction requirements are addressed.
2. Site/Environment—Methods are sought that reduce the environmental impact of construction on the project site and identify impacts on the surrounding environment.
3. Material Selection—Select environmentally friendly building materials and products that are nontoxic (and preferably recyclable and renewable) and locally produced reducing CO₂ emissions and promoting the local economy.
4. Waste Prevention—Approaches to reduce and eliminate waste on construction projects are identified.
5. Recycling—At each phase of construction materials to be recycled and methods to support the onsite recycling effort are identified.
6. Energy—Strategies to ensure and improve the building's energy performance, reduce energy consumed during construction, and identify opportunities to use renewable energy sources.
7. Build with recycled and renewable materials—This means specifying materials that contain recycled content or are reusable to facilitate the future reuse of a facility and its systems, equipment, products, and materials. Examples are the use of recycled steel products, high-volume fly ash concrete products, and concrete masonry units, as well as forest stewardship council (FSC)-certified wood products.
8. Construction Technologies—Ascertain which technologies can be used during construction to improve efficiency and reduce waste (especially paper).
9. Health and Safety—Procedures to improve the quality of life for construction workers are identified.

10. Indoor Environmental Quality (IEQ)—Appropriate methods should be applied to ensure IEQ, such as the use low-VOC paints and adhesives as well as Carpet & Rug Institute Green Label Plus carpets and low-emitting certified products. Smoking on premises should be prohibited.

In 2004, the Department of Energy (DOE) had also developed an Environmental Protection Program, the goals and objectives of which are “to implement sound stewardship practices that are protective of the air, water, land, and other natural and cultural resources impacted by DOE operations and by which DOE cost effectively meets or exceeds compliance with applicable environmental; public health; and resource protection laws, regulations, and DOE requirements. This objective must be accomplished by implementing Environmental Management Systems (EMSs) at DOE sites. An EMS is a continuing cycle of planning, implementing, evaluating, and improving processes and actions undertaken to achieve environmental goals.” Some of these goals and objectives include:

1. Goal: Protect the environment through waste prevention.

Objective: Minimize environmental hazards, protect environmental resources, minimize life cycle cost and liability of DOE programs, and maximize operational capability by eliminating or minimizing the generation of wastes that would otherwise require storage, treatment, disposal, and long-term monitoring and surveillance.

2. Goal: Protect the environment through reduction of environmental releases.

Objective: Minimize environmental hazards, protect environmental resources, minimize life cycle cost and liability of DOE programs, and maximize operational capability by eliminating or minimizing the use of toxic chemicals and associated releases of pollutants to the environment that would otherwise require control, treatment, monitoring, and reporting.

3. Goal: Protect the environment through environmental preferable purchasing.

Objective: Minimize environmental hazards, conserve environmental resources, minimize life cycle cost and liability of DOE programs, and maximize operational capability through the procurement of recycled content, bio-based content and other environmentally preferable products thereby minimizing the economic and environmental impacts of managing toxic by-products and hazardous wastes generated in the conduct of site activities.

4. Goal: Protect the environment through incorporation of environmental stewardship in program planning and operational design.

Objective: Minimize environmental hazards, conserve environmental and energy resources, minimize life cycle cost and liability of DOE programs, and maximize operational capability by incorporating sustainable environmental stewardship in the commissioning of site operations and facilities.

5. Goal: Protect the environment through postconsumer material recycling. Objective: Protect environmental resources, minimize life cycle cost of DOE programs, and maximize operational capability by diverting materials suitable for reuse and recycling from landfills thereby minimizing the economic and environmental impacts of waste disposal and long-term monitoring and surveillance.

All project team members need to have a clear understanding of LEED certification and the role it can play in improving property owners' competitive edge in an increasingly green market. Certification also gives independent verification that a building has achieved accepted standards in these areas, as outlined in the LEED Green Building Rating System. LEED certification of a project provides recognition of its quality and environmental stewardship and is widely accepted and recognized by both the public and private sectors, further fueling the demand for green building certification systems, both in the United States and globally.

Since its inception in 1998, the LEED rating system has made significant inroads into the mainstream design and construction industry, and contractors and property developers are realizing that they too can contribute toward a project's success in achieving green objectives. This would be accomplished first by understanding the LEED process and the specific role they can play in achieving LEED credits, and then, through early involvement and participation throughout the different project phases by incorporating a team approach in an integrated design process. Though, measurable benchmarks are required to achieve verification and confirm a building's acceptable performance. In this respect ASHRAE puts this responsibility of defining design intent requirements squarely on the shoulders of the owner. However, it is not possible to correctly evaluate a building or project, unless certain relevant information is made available regarding the criteria on which the project's design and execution was based. A project's plans and specifications, etc. need, therefore, to be prepared in a manner that can achieve measurable results. Otherwise a meaningful assessment to see if a project has met the required results and original design intent is not possible. Moreover, before measurable green criteria can be established, it is necessary to first agree on a finite definition of green construction and to specify exactly what is required to be achieved.

The National Association of Home Builders (NAHB) has put forward a set of green home building guidelines that “should be viewed as a dynamic document that will change and evolve as new information becomes available, improvements are made to existing techniques and technologies, and new research tools are developed.” In this respect, NAHB says that their Model Green Home Building Guidelines were written to facilitate moving environmentally friendly home building concepts further into the mainstream marketplace and is one of two rating systems that make up NAHBGreen, the National Green Building Program.

Although the US housing market is sometimes unpredictable, Ed Brady, chairman of the NAHB who is both a home builder and developer, said the February (2016) bounce back in sales “is in line with our builders’ reports that the housing market continues to recover at a slow but steady pace”. This is reaffirmed by NAHB Chief Economist Robert Dietz who says, “While builders contend with industry headwinds such as labor shortages, relatively low mortgage interest rates and solid job growth should keep the housing market moving ahead as we enter the spring buying season.”

The NAHB point system consists of three different levels of green building—Bronze, Silver, and Gold which are available to builders wishing to use these guidelines to rate their projects. NAHB stipulates that, “At all levels, there are a minimum number of points required for each of the seven guiding principles to assure that all aspects of green building are addressed and that there is a balanced, whole-systems approach. After reaching the thresholds, an additional 100 points must be achieved by implementing any of the remaining line items.” [Table 2.1](#) outlines the points needed to achieve one of the three different level rating thresholds of green building.

Table 2.1 The NAHB point system is available to builders wishing to use these guidelines to rate their projects

	Bronze	Silver	Gold
Lot design, preparation, and development	8	10	12
Resource efficiency	44	60	77
Energy efficiency	37	62	100
Water efficiency	6	13	19
Indoor environmental quality	32	54	72
Operation, maintenance, and homeowner education	7	7	9
Global impact	3	5	6
Additional points from sections of your choice	100	100	100

There are three levels of Green Building with this system: Bronze, Silver, and Gold.

While Green Buildings may appear to be similar to traditional building forms, the conceptual approach in sustainable design differs substantially in that it revolves around a concern for the environment by extending the life span of natural resources, provide human comfort and well-being, security, productivity, and energy efficiency. This approach offers many benefits such as reduced operating costs including energy, and water, as well as other intangible benefits. For example, according to the Indian Green Building Council (IGBC) which administers the LEED India rating system, there are a number of salient attributes of a Green Building, including:

- Minimal disturbance to landscapes and site condition
- Use of Recycled and Environmental Friendly Building Materials
- Use of Non-Toxic and recycled/recyclable Materials
- Efficient use of Water and Water Recycling
- Use of Energy-Efficient and Eco-Friendly Equipment
- Use of Renewable Energy
- Indoor Air Quality for Human Safety and Comfort
- Effective Controls and Building Management Systems

The Whole Building Design Guide (WBDG), a program of the National Institute of Building Sciences (NIBS), also outlines specific objectives and principles of sustainable design:

Objectives:

1. Avoid resource depletion of energy, water, and raw material.
2. Prevent environmental degradation caused by facilities and infrastructure throughout their life cycles.
3. Create built environments that are livable, comfortable, safe, and productive.

Principles:

1. Optimize site potential
2. Optimize energy use
3. Protect and conserve water
4. Use environmentally preferred products
5. Enhance IEQ
6. Optimize operations and maintenance procedures

James Woods, executive director of The Building Diagnostics Research Institute notes, "Building performance is a set of facts and not just promises. If the promises are achieved and verified through measurement, beneficial

consequences will result and risks will be managed. However, if the promises are not achieved, adverse consequences are likely to lead to increased risks to the occupants and tenants, building owners, designers and contractors; and to the larger interests of national security and climate change.”

Alan Bilka, another sustainability design expert, with ICC Technical Services, also correctly points out that, “Over time, more and more “green” materials and methods will appear in the coders and/or have an effect on current code text. But the implications of green and sustainable building are so wide and far reaching that their effects will most certainly not be limited to one single code or standard. On the contrary, they will affect virtually all codes and will spill beyond the codes. Some green building concepts may become hotly contested political issues in the future, possibly requiring the creation of new legislation and/or entirely new government agencies.”



2.2 GREEN BUILDING EVALUATION SYSTEMS

There are today a large number of available building rating systems in the United States and around the world. Globally, these voluntary building rating systems have played an important role in raising public awareness and popularizing the concept of sustainability and green design. However, the majority of these rating systems have been tailored specifically to suit the building industry of the country where they were initially developed. For example, in 2006 China’s Ministry of Construction (MoC) introduced a Green Building Evaluation Standard based on a three-star system (i.e., grants three levels of ratings) and was a first attempt by China to create a local green building standard. The purpose of the Chinese system which incidentally has many striking similarities with the LEED system is to create a voluntary rating system that will inspire green development. Likewise in 1999, Taiwan’s Architecture and Building Research Institute of the Ministry of the Interior formulated a *Green Building Illustration and Assessment Handbook* to promote green buildings in Taiwan. In that same year, Taiwan introduced a Green Building Evaluation and Labeling System (GBELS) and a Green Building Committee was established to evaluate, encourage, and to award green building designs (Chinese Architecture and Building Centre, 2007). Again, in India a US-based LEED rating system is being promoted by CII Green Business Centre, Hyderabad. With a view to India’s agroclimatic conditions—especially the preponderance of non-AC buildings, it was decided to set up a National Rating System—GRIHA that is applicable for all the different types of building in different climatic zones of the country.

These are but a few of the many evaluation systems in place within the United States and world wide. The development of such systems is necessary because buildings have major environmental impacts over their entire life cycle. Today, many of our natural resources such as ground cover, forests, water, and energy are being depleted to give way to new building construction. We have found that green buildings only minimally deplete the natural resources during their construction and operation. Generally speaking, to be able to make a proper evaluation of how “green” a building is, it is necessary to evaluate and consider the application and incorporation of the following green building design principles and their integration into the design process:

1. Sustainable site planning
2. Building envelope design should minimize adverse environmental impact
3. Building system design: incorporate high-performance/energy-efficient HVAC, lighting, electrical (e.g., ENERGY STAR), and water-heating systems. Ensure commissioning of systems
4. Integration of renewable energy sources such as solar, wind, and alternative energy to generate energy onsite
5. Water efficiency and waste management
6. Use of ecologically sustainable materials and products with high recycled content are rapidly renewable and have minimum off gassing of harmful chemicals, etc.
7. IEQ—maintain indoor air quality and thermal and visual comfort



2.3 USGBC LEED CERTIFICATION AND RATING SYSTEM

Comprehensive documentation can be found on the USGBC and GBCI websites (www.leedbuilding.org; www.gbci.org), from LEED accreditation requirements to reference guides, careers, and e-newsletters. The most appropriate manner to be able to contribute to the success of a LEED project is to become familiar with the many requirements and opportunities offered by the new program. To succeed in earning LEED certification for a project, the process must start in the initial planning stage, where the stakeholders involved make a commitment to pursue certification. Once this is done, the next step is to register the project and payment of an initial flat fee. The Green Building Certification Institute (GBCI) has recently assumed responsibility for administrating the LEED certification

for all commercial and institutional projects registered under a LEED Rating System. When the project is completed, and all the numbers are in including preparation of all supporting documentation, the project is submitted for evaluation and certification. Once this has been determined, the project is listed on the LEED project list. The summary sheet showing the tally of credits earned becomes available for most certified projects. To assist in the certification process, there is a Policy Manual that can be accessed online that gives an overview of the program requirements pertaining to the LEED Green Building Rating System and identifies the policies put in place by the GBCI for the purposes of administering the LEED certification process.

2.3.1 LEED Process Overview

The USGBC and GBCI websites should always be checked for the latest updates. Basically the latest LEED Green Building Rating System consists of a set of performance standards used in the certification of commercial, institutional, and other building types in both the public and private sectors with the intention of promoting healthy, durable, and environmentally sound practices. A LEED certification is an indisputable evidence of independent, third-party verification that a building project has achieved the highest green building and performance measures according to the level of certification achieved. Setting up an integrated project team to include the major stakeholders of the project such as the developer/owner, architect, engineer, landscape architect, contractor, and asset and property management staff is helpful to jump starting the process. This implementation of an integrated, systems-oriented approach to green project design, development, and operations can yield significant synergies while enhancing the overall performance of a building. The project's goals should be clarified and delineated during the initial project team meetings, and the LEED certification level will be determined.

LEED v4 is the latest version of the world's premier benchmark for high-performance green buildings. This version builds on the fundamentals of earlier versions while offering a new system that prepares all LEED projects in a portfolio to perform at a higher level. Projects are required to adhere to the LEED Minimum Program Requirements (MPRs) to achieve LEED certification. MPRs describe the eligibility for each system and are intended to "evolve over time in tandem with the LEED rating systems." Though there are eight requirements that are standardized for all systems, the thresholds and levels apply differently for each system. Nevertheless, LEED

v4 projects must comply with all the applicable MPRs outlined below. To clarify the MPRs, one of the categories will be used as an example—New Construction and Major Renovations:

1. The project must comply with all applicable federal, state, and local building-related environmental laws and regulations where the project is located.
2. A LEED project must consist of a complete, permanent building or space. It must be designed for, constructed on, and operated on an already existing land. LEED projects are required to include new, ground-up design and construction or major renovation of at least one complete building. Moreover, construction prerequisites and credits may not be submitted for review until substantial completion of construction has been achieved.
3. The project must employ a reasonable site boundary:
 - a. The LEED project boundary is to include all contiguous land that is associated with and supports normal building operations for the LEED project.
 - b. The LEED project boundary must normally only include land that is owned by the party which owns the LEED project.
 - c. LEED projects located on a campus must contain project boundaries so that if all the campus buildings become LEED certified, then 100% of the gross campus land area would be included within a LEED boundary.
 - d. Any given parcel of real property may only be attributed to a single LEED project building.
 - e. Any tampering with a LEED project boundary is completely prohibited.
4. LEED project must comply with minimum floor area requirements by incorporating a minimum of 1000 sq. ft. (93 square meters) of gross floor area.
5. LEED projects must comply with minimum full-time equivalent occupancy rates (FTE). One or more FTE must be served calculated as an annual average to use LEED in its entirety.
6. Project owners must consent to sharing whole-building energy and water usage data with USGBC and/or GBCI for a period of at least 5 years.
7. The gross floor area of the LEED project must conform to a minimum building area to site area ratio—building must not be less than 2% of the gross land area within the LEED project boundary.

8. Registration and certification activity must comply with reasonable timetables and rating system sunset dates which basically means that if a LEED 2009 project is inactive for 4 years, the GBCI reserves the right to cancel the registration.

2.3.2 How LEED Works

LEED is a point-based system where building projects earn LEED points for satisfying specific green building criteria. The awarding of points relative to performance is covered under five environmental categories: Sustainable Sites (SSs), Water Efficiency (WE), Energy and Atmosphere (EA), Materials and Resources (MR), and IEQ. Additionally there is Innovation in Design (ID), which addresses sustainable building expertise as well as design measures not covered under the five environmental categories and Regional Priority (RP). Designers can select the points that are most appropriate to their projects to achieve a LEED rating. A total of 100 base points +10 points (6 possible ID and 4 RP points) are possible. The number of points the project earns determines the level of LEED Certification the project receives, i.e., Platinum, Gold, Silver, or certified ratings are awarded.

When the USGBC first introduced the LEED green building rating system, Version 1.0 in December 1998, it was considered by all to be a pioneering effort. Since then the LEED Green Building Rating System has inspired and prompted global adoption of sustainable green building practices through the adoption and execution of universally understood and accepted tools and performance criteria. And today, LEED has become the leading means for certifying green buildings in the United States and has recently released a new version, LEED v4, which succeeds LEED 2009 (formerly known as LEED v3), and which is the first major LEED overhaul since Version 2.2 came out in 2005. LEED v4 has been significantly transformed by the many changes, both major and minor to the rating system and its priorities. It should be mentioned that the LEED v4 version now also includes Location and Linkage (transportation) and Awareness and Education. The development of LEED v4 took more than 3 years for final approval.

Many of the changes in LEED 2009 and the newer LEED v4 version are designed to address much of the criticism levied against the LEED system, including an entirely new weighting system which refers to the process of redistributing the available points in LEED in a manner that a credit's point value more accurately reflects its potential to either mitigate the negative or promote positive environmental impacts of a building. Thus in the

latest LEED versions, credits that most directly address the most significant impacts are given the greatest weight, subject to the system design parameters described above. This has resulted in a significant change in allocation of points compared with earlier LEED rating systems. Generally speaking, the modifications reflect a greater relative emphasis on the reduction of energy consumption and greenhouse gas emissions associated with building systems, transportation, the embodied energy of water and materials, and where applicable, solid waste (e.g., for Existing Buildings: Operations & Maintenance).

Additional improvements include an increased opportunity for innovation credits, and a new opportunity for achieving bonus points for RP credits. A less obvious revision in LEED 2009 is the reduction of possible exemplary performance credits from a maximum of four to a maximum of three. The intention here was to return to the original intent of the credit, which is to encourage projects to pursue innovation in green building. There are numerous other important modifications and improvements in LEED 2009 and LEED v4 that are discussed below and the following chapters.

2.3.3 The LEED Points Rating System

LEED is a continually evolving basic point-based system that has set the green building standard and has made it the most widely accepted green program in the United States.

The various LEED categories differ in their scoring systems based on a set of required “prerequisites” and a variety of “credits” in seven major categories as outlined above. In LEED v2.2 for new construction and major renovations for commercial buildings, there were 69 possible points, and buildings were able to qualify for four levels of certification.

LEED v4 is a significant improvement on earlier LEED versions and has become much less complicated to figure out how many points a building receives and where that places it in the continuum of green building achievement. The new USGBG LEED Green Building certification levels for all systems are also more consistent and are shown below:

Certified: 40–49 points

Silver: 50–59 points

Gold: 60–79 points

Platinum: 80 plus points

The number of points available per LEED system has been increased so that all LEED systems have 100 base points as well as 10 possible innovation and regional bonus points which bring the possible total points

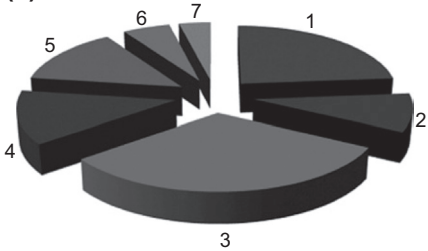
(a) LEED 2009 Point Distribution – NC

1. Sustainable sites (26 pts)
2. Water efficiency (10 pts)
3. Energy & Atmosphere (35 pts)
4. Materials & Resources (14 pts)
5. Indoor environmental quality (15 pts)
6. Innovations in design (6 pts)
7. Regional priority (4 pts)

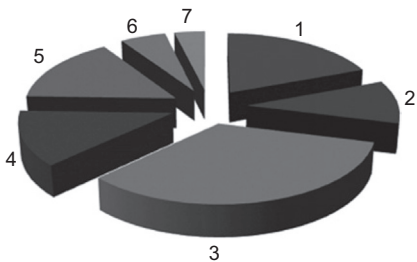
(b) LEED 2009 Point Distribution – CI

1. Sustainable sites (21 pts)
2. Water efficiency (11 pts)
3. Energy & Atmosphere (37 pts)
4. Materials & Resources (14 pts)
5. Indoor environmental quality (17 pts)
6. Innovations in design (6 pts)
7. Regional priority (4 pts)

Figure 2.1 (a) Pie chart showing the LEED NC v2009 and (b) LEED CI v2009 point-distribution system, which incorporate a number of major technical advancements focused on improving energy efficiency, reducing carbon emissions, and addressing additional environmental and human health concerns.

achievable for each category to 110. [Fig. 2.1](#) depicts pie charts showing the LEED v2009 for new construction and commercial interiors. Of note, project teams can continue to choose to use LEED v2009, rather than the LEED v4 rating system, until October 2016. After that deadline, LEED v4 will become mandatory for new projects. [Figs. 2.2 and 2.3](#) are examples of buildings that have received various levels of LEED certifications.

While the previous maximum achievement in earlier versions of LEED–NC was 69 points, in LEED 2009 this was increased to 100, which has remained the same for LEED v4, although it remains unclear sometimes how the added 31 points are distributed. Aurora Sharrard, research manager at Green Building Alliance (GBA) says, “The determination of which credits achieve more than 1 point (and how many points they achieve) is actually the most complex part of LEED 2009. LEED has always implicitly weighted buildings’ impacts by offering more credits in certain sections. However, in an effort to drive greater (and more focused) reduction of building impact, the USGBC is now applying explicit weightings to



Figure 2.2 Interior of BP America's new Government Affairs Office in Washington, DC designed by Fox Architects. The 22,000 sq. ft. building achieved a LEED platinum level. *Source: Fox Architects.*

(a)



(b)

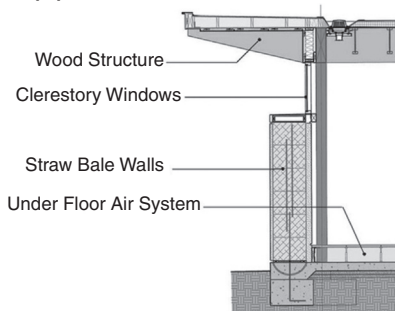

Figure 2.3 (a) The Santa Clarita Transit Maintenance is one of the first LEED Gold-certified straw-bale buildings in the world. The resource- and energy-efficient transit facility was designed by HOK and exceeds California Energy Efficiency Standards by more than 40%, securing a new standard for straw-bale in high-performance building design. (b) Diagram shows section taken through exterior wall of transit facility. The designers reportedly opted for a solar photovoltaic canopy to shade buses and provide nearly half of the building's annual energy needs. An electronic monitoring system is in place to track thermal comfort, energy efficiency, and moisture levels. *Source: HOK Architects.*

all LEED credits. The existing weighting scheme was developed by the National Institute of Standards and Technology (NIST). The USGBC hopes to have its own weighting system for future LEED revisions, but currently, LEED credits are proposed to be weighted based on the following categories, which are in order of weighted importance:

- Greenhouse gas emissions
- IEQ fossil fuel depletion
- Particulates
- Water use
- Human health (cancer)
- Ecotoxicity
- Land use
- Eutrophication
- Smog formation
- Human health (noncancer)
- Acidification
- Ozone depletion

The new weighting preferences in the LEED 2009 system puts much greater emphasis on energy which is very appropriate as this addresses some of the criticism levied against earlier versions of the LEED Rating System. There has also been an increase in the Innovation and Design (ID) credits from 4 points to 5. An additional point can be achieved for having a LEED Accredited Professional (LEED AP) on the project team which brings the total ID points to 6. The introduction of the new category of RP also adds another potential 4 bonus points (bringing the total points possible to 110). For updates to the latest LEED version of the rating system (LEED v4), visit: www.USGBC.org.

2.3.4 LEED Building Certification Model

During LEED v3 (April 2009), the GBCI assumed responsibility to manage the review and verification process for projects seeking certification under the LEED Green Building Rating System. The GBCI, which is an independent nonprofit organization, was established in January 2008 with the support of USGBC. The GBCI provides third-party project certification and professional credentials recognizing excellence in green building performance and practice. The updated LEED v3 is an improved ISO-compliant certification process that is designed to grow with the green building movement. In April 2014, the International WELL Building Institute and the GBCO announced a formal collaboration that will streamline how LEED and WELL work

together and demonstrates that green building and health and wellness go hand in hand. However, the USGBC will continue to administer the development and ongoing improvement of the LEED rating system and will remain the primary source for LEED and green building education.

The new GBCI building certification infrastructure has recently added on a network of 10 well-respected certification organizations that are accredited to ISO standard 17021. These organizations are recognized for their role in certifying organizations, processes, and products to ISO and other standards and are listed below:

- ABS Quality Evaluations, Inc. (www.abs-qe.com).
- BSI Management Systems America, Inc. (<http://www.bsi-global.com/www.bsigroup.com>).
- Bureau Veritas North America, Inc. (www.us.bureauveritas.com).
- DNV Certification (<http://www.dnv.us/certification/managementsystems/index.asp>).
- Intertek (www.intertek-sc.com).
- KEMA-Registered Quality, Inc. (www.kema.com).
- Lloyd's Register Quality Assurance Inc. (www.lrqausa.com).
- NSF-International Strategic Registrations (www.nsf.org).
- SRI Quality System Registrar, Inc. (www.sri-i.com).
- Underwriters Laboratories-DQS Inc. (www.ul.com/mss).

Additional information with respect to these programs can be obtained from the GBCI website.

2.3.5 What Is New?

After 3 years of continuous evaluation and collaboration, we witness a number of changes from LEED v3 to LEED v4 which are rather subtle and intricate. According to the USGBC, the LEED v4 is a further improvement on its predecessor, LEED 2009 (i.e., v3) because it:

- Takes a more performance-based approach to IEQ to ensure improved occupant comfort.
- Includes a focus on materials that goes beyond how much is used to get a better understanding of what is in the materials we specify for the buildings and the effect those components have on human health and the environment.
- Brings the benefits of smart grid thinking to the forefront with a credit that rewards projects for participating in demand response programs.
- Provides a clearer picture of water efficiency by evaluating total building water use.

In fact, with the previous overhauling of the LEED Online v3 Rating System, a greatly improved system has emerged—which is more appropriate and provides enhanced functionality to improve efficiency and productivity compared with its predecessors. According to the GBCI, the LEED 2009 version is “faster, smarter and a better user experience. It is designed to be scalable and more robust, through improved design, a more intuitive user interface, better communication between project teams and certifying bodies, and upgrades that respond to the changes in the LEED 2009 rating system.” The GBCI also cites on its website some of the new project management improvement tools incorporated into v3 such as:

- Project organization—the ability to sort, view, and group LEED projects according to a number of project traits, such as location, design or management firm, etc.
- Team member administration—increased functionality and flexibility in making credit assignments, adding team roles, and assigning them to team members. For example, credits are now assigned by team member name rather than by project role.
- Status indicators and timeline—clearer explanation of the review and certification process and highlights steps as they are completed in specific projects. The system now displays specific dates related to each phase and step, including target dates that each review is to be returned to the customer.
- LEED Support for Certification Review and Submittals.
- LEED Online v3 offers many other enabling features to support the LEED certification review process, as well as enhancements to the functionality of submittal documentation and certification forms:
 - End-to-end process support—the new system will guide project teams through the certification process, from initial project registration through the various review phases. Furthermore, it will provide assistance to beginners during the registration phase to help them determine the type of LEED rating system that is best suited for their project.
 - Improved midstream communication—a midreview clarification page allows a LEED reviewer to contact the project team through the system when minor clarifications are required to complete the review.
 - Data linkages—LEED Online v3 automatically fills out fields in all appropriate forms after user inputs data the first time, which saves time and helps ensure project-wide consistency. Override options are available when required.

- Automatic data checks—new system alerts users when incomplete or required data are missing, thus allowing user to correct error before application submission, thus avoiding delays.
- Progressive, context-based disclosure of relevant content—upon selection of an option, the new system will simplify process of completing forms by only showing data fields that are relevant to the customer’s situation and hiding all extraneous content.



2.4 THE CHALLENGE OF THE GREEN GLOBES RATING SYSTEM

The Green Globes website (www.greenglobes.com/) describes the system as “The Practical Building Rating System” and says that, “The Green Globes system is a revolutionary building environmental design and management tool. It delivers an online assessment protocol, rating system and guidance for green building design, operation and management. It is interactive, flexible and affordable, and provides market recognition of a building’s environmental attributes through third-party verification.” Green Globes is certainly less complicated than USGBC’s LEED rating system. It employs a straightforward questionnaire-based format, which is written in lay terms and is fairly easy to complete even if you lack environmental design experience. The Questions are typically of a Yes/No type and are grouped broadly under seven modules of building environmental performance (management, site, energy, water, resources, emissions, indoor environment). Upon completing the questionnaire, a printable report is automatically generated. Fig. 2.4 is a photo of Blakely Hall, the first Green Globes rated building in the United States which is community center and town hall for Issaquah Highlands, a planned community near Seattle, Washington, which earned two Globes (out of four possible) in the Green Building Initiative’s Green Globes. The building incorporates a variety of green attributes such as high energy and water efficiency, integration of daylighting, and the use of locally sourced materials. The implementation of a construction waste management plan also helped divert more than 97% of waste from landfill. Blakely Hall is an example of a “green” building that has achieved various awards including a LEED Silver award.

The idea and market for green buildings has been growing rapidly, and although there are a number of green building rating systems available in the United States, the two systems most widely used for commercial structures are LEED and Green Globes (Go Green Plus). LEED Green Building Rating System is focused largely on assessing new construction sustainable



Figure 2.4 Blakely Hall is a Community Center and town hall for Issaquah Highlands, a planned community near Seattle, Washington. It consists of 7000 sq. ft. and built to a budget of US \$1,500,000. It is used mainly as a meeting place for numerous clubs and groups at Issaquah Highlands. Blakely Hall is the first building in the United States to earn a Green Globes Certification (earned two Globes out of four possible) as well as a LEED Silver award.

high-performance buildings, although existing buildings are also included in LEED Rating System (Fig. 2.6). Go Green mainly targets existing buildings owners who want to have a more environmentally friendly building. In this section, we will analyze and compare the Green Globes Rating System with the LEED Rating System. While Green Globes currently has a relatively small share of certified buildings in the United States which pales with LEED's certified buildings market share, it continues making a determined effort to rectify this situation (Fig. 2.5).

2.4.1 An Overview of the Green Building Initiative and Green Globes

The Green Building Initiative (GBI) is a 501(c)(3) nonprofit education organization based in Portland, Oregon. During October 2014 the GBI celebrated 10 years of promoting green building under its founder, Ward Hubbell. Its mission is to accelerate the adoption of sustainable design and construction practices that result in energy-efficient, healthier, and environmentally sustainable buildings by promoting credible and practical green building approaches for residential and commercial construction. Ward Hubbell, served as President of GBI for almost 10 years at the discretion of an independent, multistakeholder board of directors that is comprised of



Figure 2.5 The 80,000 ft² (7400 m²) Integrated Learning Centre at Queen's University in Kingston, Ontario, received a four-leaf rating through the BREEAM/Green Leaf program, which is now accessible online as Green Globes. Designed by B+H Architects of Toronto, the project was completed in 2004. The Ottawa-based firm Green & Gold, Inc., implemented the BREEAM/Green Leaf program for the ILC and helped integrate the building analysis tool into the design process. The lighting, ventilation, and water distribution systems, in particular, contributed to the building's high rating. *Source:* interiorimages.ca.

construction professionals, product manufacturers, nonprofit organizations, university officials, and other interested parties. Upon Hubbell's departure in 2014, Jerry Yudelson, P.E., a LEED Fellow and a prominent advocate of green building, joined the Green Building Initiative (GBI) as president. "It's a new beginning," Yudelson told LEED user. And in an interview with *Building Design + Construction*, where Yudelson served as consulting editor prior to taking the helm at GBI, Yudelson claimed, "better, faster, [and] cheaper" were the key selling points of Green Globes.

History and Background: The birth of the Green Globes system lies in the Building Research Establishment's Environmental Assessment Method (BREEAM); this was exported to Canada from the United Kingdom in 1996 in cooperation with ECD Energy and Environment. Green Globes was initially developed as a rating and assessment system to monitor and assess green buildings in Canada. Canada's federal government has been using the Green Globes rating system for several years under the Green Globes name, and it has been the basis for the Building Owners and Manufacturer's Association of Canada's Go Green Plus program. Go Green was adopted by BOMA Canada in 2004 and was chosen by Canada's Department of Public Works and Government Services. Green Globes has also been adopted by the Continental Association for Building Automation (CABA) to power a building intelligence tool, called Building Intelligence Quotient (BiQ).

The Green Globes environmental assessment and rating system represents more than a decade of research and refinement by a wide range of prominent international organizations and experts. The Canadian Standards Association (CSA) first published BREEAM Canada for Existing Buildings in 1996 in which more than 35 individuals participated in its development. In 1999, ECD Energy and Environment collaborated with Terra Choice, the agency that administers the Government of Canada's Environmental Choice program, to develop a more efficient and streamlined, question-based tool that was later introduced as the BREEAM Green Leaf eco-rating program. Later that year the program led to the formation of Green Leaf for Municipal Buildings with the Federation of Canadian Municipalities. In 2000, BREEAM Green Leaf's development took another step forward by becoming an online assessment and rating tool under the name Green Globes for Existing Buildings. That same year, BREEAM Green Leaf for the Design of New Buildings was adapted for the Canadian Department of National Defense and Public Works and Government Services Canada. The program underwent a further iteration in 2002 by a panel of experts including representatives from Arizona State University, the Athena Institute, BOMA, and a number of Canadian federal departments.

In 2002, Green Globes for Existing Buildings went online in the United Kingdom as the Global Environmental Method (GEM), and endeavors were made to incorporate BREEAM Green Leaf for the Design of New Buildings into the online Green Globes for New Buildings. Green Globes for Existing Buildings was adopted and operated by BOMA Canada in 2004 under the name Go Green Comprehensive (now known as Go Green Plus). The Canadian federal government also later announced plans to adopt Go Green Plus for its entire real estate portfolio. All other Green Globes products in Canada are owned and operated by ECD Energy and Environment Canada.

Additionally in 2004, the Green Building Initiative (GBI) purchased the rights to promote and develop and distribute Green Globes for New Construction in the United States. In adapting the system, minor changes were instituted to make the system appropriate for the US market (e.g., converting units of measurement and integration with the ENERGY STAR program). The GBI also committed itself to ensuring that Green Globes continues to reflect best practices and changing opinions and ongoing advances in research and technology. To that end, GBI in 2005 became the first green building organization to be accredited as a standards developer by the American National Standards Institute (ANSI), and Green Globes rating system is also on track to become the first American National Standard

for commercial green buildings. To facilitate this, ANSI-GBI 01-2010 is under revision and is to become the basis for an improved version of Green Globes for New Construction & Major Renovations which is to be piloted in 2016. GBI's ANSI Standard and Green Globes rating system rewards users one to four globes based on a 1000 point-based rating system program for incorporating green building best practices into buildings. As part of this process, GBI has set up a technical committee and subcommittees of more than 75 building science experts, including representatives from several federal agencies, states, municipalities, universities, and leading construction firms, in addition to building developers.

As a follow up, in March 2009 the GBI and the American Institute of Architects (AIA) signed a memorandum of understanding (MOU), which states that the GBI and AIA pledge to work in concert to promote the design and construction of energy efficient and environmentally responsible buildings. An MOU was also signed between the GBI and ASHRAE to collaborate to facilitate the adoption of sustainability principles in the built environment.

2.4.2 Defining the Green Globes Rating System

The Green Globes v1 assessment protocol covers seven different areas with each area having an assigned number of points that are utilized to quantify overall building performance. These are shown in the table below (Fig. 2.6):

The process: The scoring for the seven Green Globe categories is based on a series of questions that are completed via the online questionnaire

ASSESSMENT CATEGORY	POINTS	PERCENTAGE
Project management	50	5
Site	115	11.5
Energy	360	36
Water	100	10
Resources	100	10
Emissions, effluents and other impacts	75	7.5
Indoor environment	200	20
TOTAL	1000	100

Figure 2.6 Table depicting the seven different assessment categories of Green Globes. Table shows a clear emphasis on Energy which takes up more than a third of the total points.

within the Green Globes Tool. Normally, there are pop-up “tool tips” embedded within the questionnaire to address frequently asked questions and add clarifications regarding the input data requirements that will appear during the survey. Amy Stodghill, a sustainability consultant who, by using a free 30-day trial, accessed the online Environmental Assessment for Existing Commercial Buildings comments, “It is essentially a 22 page questionnaire/survey covering energy, transportation, water, waste reduction and recycling, site management, air and water emissions, indoor air quality (IAQ), purchasing and communication. It is completed online only and is very user friendly.” The time normally required to input data and complete the survey is roughly 2–3 h per building; this does not include time required to research and gather required information for the survey.

Stodghill also noted that “Each question is weighted with points (in all totaling up to 1000). The overall rating is tracked as questions are answered. The overall rating however is based on a percentage, not on total points. This way there are no penalties for questions that are not applicable (i.e., Answering ‘no’ on water efficient Irrigation questions will not be counted against you if you do not have any landscaping).” Upon completion the Green Globes System automatically generates a report that is based on answers given. The report lists where the building stands in each major category and lists suggestions for improvement to gain a better score.

To earn a formal Green Globes rating/certification, a building has to be evaluated by an independent third party that is recognized, trained, and affiliated with GBI. Both new construction and existing buildings can be formally rated or certified within the Green Globes system. Projects that achieve a score of 35% or more of the 1000 points possible in the rating system become eligible for a Green Globes rating of one, two, three, or four globes, as follows:

- One Globe: 35–54%
- Two Globes: 55–69%
- Three Globes: 70–84%
- Four Globes: 85–100%

A summary of rating levels and how they relate to environmental achievement can be seen in [Fig. 2.7](#). However, buildings cannot be promoted as having achieved a Green Globes rating until the information submitted has been assessed by a qualified third party.





85-100%		Reserved for select buildings that serve as national or world leaders in reducing environmental impacts and efficiency of buildings.
70-84%		Demonstrates leadership in energy and environmentally efficient buildings and a commitment to continual improvement.
55-69%		Demonstrates excellent progress in reducing environmental impacts by applying best practices in energy and environmental efficiency.
35-54%		Demonstrates movement beyond awareness and a commitment to good energy and environmental efficiency practices.

Figure 2.7 Green Globes rating levels in the United States. *Source: Green Building Initiative.*

According to Green Globes-NC, projects are awarded up to 1000 points based on their performance in seven areas of assessment as follows:

1. Project Management—50 Points

The Green Globes system places an emphasis on integrated design, an approach that encourages multidisciplinary collaboration from the earliest stages of a project while also considering the interaction between elements related to sustainability. Most decisions that influence a building's performance (such as siting, orientation, form, construction, and building services) are made at the start of the project and yet it's common, even for experienced designers, to focus on environmental performance late in the process, adding expensive technologies after key decisions have been made. This is costly as well as ineffective.

To ensure that all of the relevant players are involved, the system tailors questionnaires so that input from team members is captured in an interactive manner, even on those issues which may at first appear to fall outside their mandate. For example, while site design and landscaping may come under the purview of the landscape designers, the questionnaire prompts the electrical engineer to get involved with design issues such as outdoor lighting or security. Thus the Green Globes format promotes design teamwork and prevents a situation where, despite strong individual resources, the combined effort falls short. Also included under project management are environmental purchasing, commissioning, and emergency response.

2. Site—115 Points

Building sites are evaluated based on the development area (including site selection, development density, and site remediation), ecological impacts (ecological integrity, biodiversity, air and water quality, microclimate, habitat, and fauna and flora), watershed features (such as site grading, storm water management, pervious cover, and rainwater capture), and site ecology enhancement.

3. Energy—360 Points

To simplify the process of energy performance targeting, Green Globes-NC directs users to the Web interface used for the ENERGY STAR Target Finder software, which helps to generate a realistic energy consumption target. As a result, an aggressive energy performance goal can be set—with points awarded for design and operations strategies that result in a significant reduction in energy consumption—as compared to actual performance data from real buildings. As previously stated, Green Globes is the only green rating system to use energy data generated through the US Department of Energy's Commercial Buildings Energy Consumption Survey (CBECS), which is widely considered to be the most accurate and reliable source of energy benchmarking information. But in addition to overall consumption, projects are evaluated based on the objectives of reduced energy demand (through space optimization, microclimatic response to site, daylighting, envelope design, and metering), integration of "right sized" energy-efficient systems, on-site renewable energy sources, and access to energy-efficient transportation.

4. Water—100 Points

Projects receive points for overall water efficiency as well as specific water conservation features (such as submetering, efficiency of cooling towers, and irrigation strategies), and on-site treatment (of gray water and wastewater).

5. Resources—100 Points

The resources section covers building materials and solid waste. It includes points for materials with low environmental impact (based on life cycle assessment), minimal consumption and depletion of resources (with an emphasis on materials that are reused, recycled, bio-based and, in the case of wood products, certified as having come from sustainable sources), the reuse of existing structures, building durability, adaptability and disassembly, and the reduction, reuse, and recycling of waste.

6. Emissions, Effluents, and Other Impacts—75 Points

Points in this section are awarded in six categories, including air emissions, ozone depletion and global warming, protection of waterways and impact on municipal wastewater treatment facilities, minimization of land and water pollution (and the associated risk to occupants' health and the local environment), integrated pest management, and the storage of hazardous materials.

7. Indoor Environment—200 Points

According to the US EPA, indoor air can be up to 10 times more polluted than outdoor air, even in cities where the quality of outdoor air is poor. This has obvious health implications, but the consequences are also economic. A study by Lawrence Berkeley National Laboratory found that improving indoor air at work could save US businesses up to \$58 billion in lost sick time each year, with another \$200 billion earned in increased worker performance. The Indoor Environment section evaluates the quality of the indoor environment based on the effectiveness of the ventilation system, the source control of indoor pollutants, lighting design and the integration of lighting systems, thermal comfort, and acoustic comfort.

According to GBI, the process for obtaining formal Green Globes rating/Certification is quite straightforward and consists of implementing the following steps:

- Step 1: Purchase a subscription to either Green Globes NC or the Continental Improvements of Existing Buildings (CIEB) program.
- Step 2: Log into Green Globes at the GBI website with a username and password.
- Step 3: Select the tool purchased (NC or CIEB) to link to Green Globes.
- Step 4: Add a building and enter the basic building information.
- Step 5: Use step-through navigation and the building dashboard to complete the survey.
- Step 6: Print the Report of the building's projected rating and obtain feedback using automatic reports.
- Step 7: Order a third-party assessment and Green Globes rating/certification (if the automated report indicates a predicted rating of at least 35% of 1000 points).
- Step 8: Schedule and complete a third party building assessment. Third-party assessment for Green Globes-NC occurs in two comprehensive stages: The first stage includes a review of the Construction Documents developed through the design and delivery process. The second stage is a walk-through of the building postconstruction.
- Step 9: Receive the Green Globes Rating & Certification.

2.4.3 Green Globes—An Alternative to LEED?

The Green Globes rating system has generated a great deal of interest and discussion since its introduction into the United States as opposed to another building certification program, namely, LEED Green Building Rating System. Firstly, it is important to bear in mind, that there are a great deal of similarities between the two initiatives, largely because they share common roots and also because they share common ideas of green buildings. However, there are several significant differences that are highlighted below.

The origin of the Green Globes Canada system lies in the BREEAM which was developed in the UK and which was later published in 1996 by the CSA. One of BREEAM's creators, ECD Consultants, Ltd., used it as the basis for a Canadian assessment method called BREEAM Green Leaf. At first, BREEAM Green Leaf was created to allow building owners and managers to self-assess the performance of their existing buildings. Green Globes was then developed into a Web-based application of Green Leaf by ECD.

The Green Globes system thus became a Web-based green building performance interactive software tool (from Canada) and today competes with the more popular and better known, though more complicated and more expensive LEED system from the U.S. Green Building Council (USGBC)—a nonprofit organization based in Washington, DC. Green Globes was introduced to the US market as a potentially viable alternative to the USGBC's LEED Rating System. The Green Building Initiative (GBI) was established to promote the use of the National Association of Home builders' (NAHB) Model Green Home Building Guidelines and has recently expanded into the nonresidential building market by licensing Green Globes for use in the United States. GBI is supported by various industry groups including the Wood Promotion Network that object to certain provisions in LEED and, as trade associations, are prohibited from joining the USGBC.

When Green Globes was first released in Canada in January 2002, it consisted of a series of questionnaires, customized by project phase and the role of the user in the design team (e.g., architect, mechanical engineer, or landscape architect). A total of eight design phases are supported. A separate Green Globes module (Green Globes-CIEB) is available for assessing the performance of existing buildings. The questionnaires produce design guidance appropriate to each team member and project phase. Green Globes users can order a Green Globes third party assessment at any time—upon purchasing a subscription, during the completion of the questionnaire, or

after completion of the questionnaire. After an online self-assessment is completed and payment is made, a GBI representative contacts the project manager or project owner to schedule the assessment and provide the assessor name and contact information. Completion of the preassessment checklist which can be downloaded from the Green Globes Customer Training area helps prepare for the assessment process.

Methods to formally rate and certify programs are necessary to provide a mechanism to ensure that new construction project teams or facilities management staff is fully aware of the environmental impact of design and/or operating management decisions. It also offers a visible means to quantify/measure a project's performance and allows recognition for their achievements and hard work at the end of the process. Green Globes is designed to be cost effective and through its value-added online system and a comprehensive yet streamlined in person third-party review process, significant savings on consulting fees are made that were normally associated with green certification. There is an annual per building license fee for use of the online tool as well as a third-party assessment fee. Rates are based on a number of factors including size of project (hectares/acres), number of integrated developments, and location (environmentally sensitive areas). Users can register/subscribe for both the annual license for the online Green Globes tools and choose to purchase a third-party assessment (required for certification). Third-party assessor travel expenses are separately billed (Fig. 2.8).

It is estimated that the United States is home to more than 100 million buildings, which adds to the urgency to improve the performance of existing structures as a necessary prerequisite for widespread energy efficiency. The GBI says that "The missing element—until last year when GBI introduced Green Globes-CIEB—was a practical and affordable way to measure and monitor performance on an ongoing basis. Green Globes-CIEB allows users to create a baseline of their building's performance, evaluate interventions, plan for improvements, and monitor success—all within a holistic framework that also addresses physical and human elements such as material use and indoor environment."

Below are some of the costs currently required with respect to the Green Globes rating system:

Green Globes Existing Building Rating/Certification Package: \$5270*
Per Building

Green Globes New Construction Rating/Certification Package: \$7270*
Per Building



Figure 2.8 New 356,000 sq. ft. Newell Rubbermaid Corporate Headquarters in Atlanta, GA, which achieved a two Globe rating using the Green Globes New Construction module. *Source: Green Building Initiative.*

Software subscriptions costs	Price
Green Globes–CIEB existing building 1 year subscription	\$1000
Green Globes New Construction	
One project subscription	\$500
Three project subscription	\$1500
Ten project subscription	\$2500

Note: A Green Globes subscription is required for third party assessment/certification.

Third party assessments/Green Globes certification

Green Globes–CIEB assessment/rating	\$3500★
Green Globes NC Stage I assessment	\$2000
Green Globes NC Stage II assessment/rating	\$4000★
Green Globes NC Stage I and II assessment/rating	\$6000★

Note: ★Pricing for buildings over 250,000sq. ft. in size or departing significantly from standard commercial building complexity will be custom quoted prior to assessment services being performed.

Travel for GBI Assessor to/from building location: Invoice actual expenses +20% after assessment OR Pay a flat fee of \$1000 upfront.

The Green Globes building rating system provides a LEED alternative assessment tool for characterizing a building's energy efficiency and environmental performance. The Green Globes system also provides guidance for green building design, operation, and management. Compared to LEED, some feel that Green Globes' appeal may be enhanced by the flexibility and affordability the system can provide while simultaneously providing market recognition of a building's environmental attributes through recognized third-party verification. And from a practical and marketing perspective, it should not be necessary to pursue LEED certification to demonstrate to tenants, their customers, clients, and building visitors that a building's owners and management are taking steps to be more environmentally responsible—when they have Green Globes.

According to Christine Ervin, former President and CEO of USGBC, “Green Globes offers several very appealing features. Interactive feedback on strategies, interactions and resources can be tailored to twenty different team roles and eight project stages. Numerical assessments are generated at stages for schematic design and construction, designed to coincide with planning and permit approvals.”

Green Globes and LEED have many similarities; part of the reason is that they both evolved from the same source—the BREEAM. For example, Green Globes and the LEED rating systems are very similar in structure. Both systems have four levels of achievement. LEED projects can achieve the following four certifications A. certified, B. silver, C. gold, or D. platinum. Similarly, Green Globes projects can achieve 1, 2, 3, or 4 globes. Both LEED and Green Globes share a common set of green building design practices. There are six focus areas for LEED and seven for Green Globes, but the focus areas are in many respects also similar.

In a University of Minnesota study conducted in 2007 that compared LEED (preversion3) with Green Globes, found that the systems were very similar. For example, the study found that “nearly 80% of the categories available for points in Green Globes are also addressed in LEED v2.2 and that over 85% of the categories specified in LEED v2.2 are addressed in Green Globes.” The study further concluded that LEED was characterized as being more rigorous, rigid, and quantitative whereas Green Globes while also rigorous, nevertheless, maintained greater flexibility. Also, Green Globes focused primarily on energy efficiency as a goal. Likewise, Green

Globes was found to be easier to work with, less costly, and less time consuming than LEED. The same study concluded that there was only moderate dissimilarity between the two rating standards, but that LEED has a slightly greater emphasis on materials choices and Green Globes has a greater emphasis on energy saving. Green Globes also more heavily weights energy systems, up to 36% of the total points needed, whereas LEED in its earlier versions limited the energy category to about 25% of the total in the rating system. However, in the new LEED v3 version, this has been appropriately addressed.

Furthermore, of the many buildings that have been evaluated with both systems, in all but two of the instances, the systems generated comparable ratings. The other two buildings were only marginally different. It should be noted here that the LEED 2009 has addressed many of these issues. In the final analysis, it appears that the primary differences between the two approaches boil down to cost and ease of use. It should be stressed that LEED v4 has been greatly improved since 2007 and currently contains significant variations with the Green Globes rating system. The University of Minnesota study also concluded that “From a process perspective, Green Globes’ simpler methodology, employing a user-friendly interactive guide for assessing and integrating green design principles for buildings, continues to be a point of differentiation to LEED™’s more complex system. While LEED™ has introduced an online-based system, it remains more extensive and requires expert knowledge in various areas. Green Globes’ web-based self-assessment tool can be completed by any team member with general knowledge of the building’s parameters.”

GBI currently oversees Green Globes in the United States. GBI has also become an accredited standards developer under the ANSI and is in the process of establishing Green Globes as an official ANSI standard. The ANSI process has always been a consensus-based process, involving a balanced committee of varying interests including users, producers, interested parties, and NGOs who basically conduct a thorough technical review through an ANSI-approved, open and transparent process. The standard continues to be monitored by this committee and will continue to updating the standard through ANSI-approved rules and procedures. ANSI-GBI 01-2010 is currently under revision and will become the basis of the next version of Green Globes for New Construction & Major Renovations to be piloted in 2016. Dr. Kibert, a noted expert on sustainable construction and who currently chairs GBI’s materials subcommittee is reviewing public comments

and proposed revisions to GBI's ANSI Standard. In addition to ANSI-GBI 01-2010: An Assessment Protocol for Green Commercial Buildings, examples of standards that already reference multiple forest certification standards include ANSI-ICC 700: National Green Building Standard and ICC's International Green Construction Code.

Neither LEED nor Green Globes (or Energy Star for that matter) provides continuous, longitudinal monitoring of energy efficiency or building performance. This indicates that building measurements and ratings are concluded on a one off basis which must then be reverified later on. This is a significant shortcoming in terms of practicality of greening existing real estate, since buildings are dynamic and rarely perform in an identical manner week after week. Green Globes-NC is the only environmental rating system that provides early feedback on your process before critical and final decisions are made. This is a proven method for taking advantage of time and cost savings opportunities through integrated design and delivery, while benefitting from a cost-effective and comprehensive third-party assessment program.

Green Globes generates numerical assessment scores at two of the eight project phases; these are the schematic design phase and construction documents phase. These scores can either be used as self-assessments internally, or they can be verified by third-party certifiers. Projects that have had their scores independently verified can use the Green Globes logo and brand to promote their environmental performance. The Green Globes questionnaire corresponds to a checklist with a total of 1000 points listed in seven categories as opposed to LEED's 100 points in seven categories (Fig. 2.9).

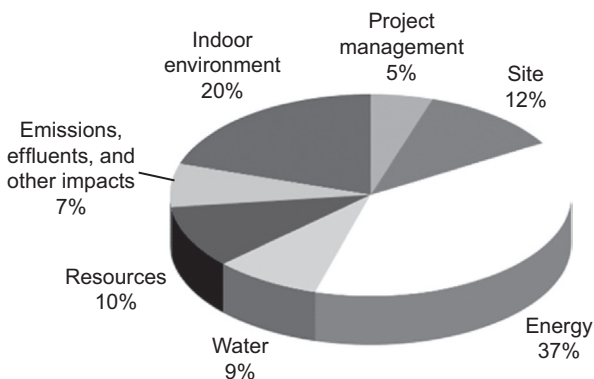

Figure 2.9 Pie diagram showing distribution of points in Green Globes Rating System. Source: Building Green LLC.

One of the differences between Green Globes and LEED is that the former offers protection against “nonapplicable criteria.” Thus if a builder marks a criterion as “N/A,” then he or she will be excused for not gaining points in those areas, which is why the actual number of points available varies by project. For example, if a building code overrides a criterion, then the criterion can be marked as “N/A.” Another example would be if points are available for designing exterior lighting to avoid glare and skyglow, but for a project with no exterior lighting, a user can select “N/A,” which removes those points from the total number available so as not to penalize the project.

A rating of one or more Green Globes is applied to projects based on the percentage of applicable points they have achieved. In Canada the ratings range from one to five Green Globes, while in the United States the lowest rating was eliminated and the rest adjusted so that the highest rating is four Globes. Ward Hubbell, former executive director of GBI, says that the objective of this was to have something that people are accustomed—to a four-stage system, which is roughly comparable with the four levels of LEED.

It appears that Green Globes is broader than LEED in terms of technical content, including points for topics such as optimized use of space, acoustical comfort, and an integrated design process. It is difficult to compare the levels of achievement required to claim points in the two systems, because they are organized differently and also because the precise requirements within Green Globes are not publicly available. Also, unlike LEED, Green Globes encourages energy reduction, and it does not require it. LEED also calls for a minimum indoor air quality performance, whereas Green Globes does not. A recently published AIA report states that LEED makes it mandatory that builders have “some documentation of the initial building energy and operational performance through fundamental commissioning,” whereas Green Globes does not.

Recognizing all the mainstream forest certification systems is one of Green Globes main attractions with strong timber-industry lobbying groups supporting GBI in the United States. (and where it differs from LEED). Green Globes is more inclusive and opposes favoring FSC over Sustainable Forestry Initiative (SFI) forest certification and recognizes timber certified through FSC as well as the American Tree Farm System (ATFS), CSA, and SFI, whereas LEED previously referenced only the Forest Stewardship Council’s program. Independent research has shown that all of these systems are in fact effective. There are more than 390 million acres of certified forest

in North America, but less than 1/6 of that amount is certified by FSC. The consensus is that legislation to encourage green building in states like Virginia and Arkansas is likely to include Green Globes in addition to LEED. Furthermore, a number of federal agencies such as the Department of the Interior are also reportedly considering an endorsement of Green Globes.

Former President of GBI, Ward Hubbell, claims that Green Globes is on a par with LEED with respect to overall achievement levels, and says, "We did carry out a harmonization exercise with LEED - not credit-by-credit; we compared objectives." The actual development of the Green Globes system in Canada, as well as its subsequent adaptation for the United States has involved many iterations and participation by a wide range of organizations and individuals. Changes originally made to adapt Green Globes for the US market do not appear to be substantive, e.g., converting units of measurement, referencing United States rather than Canadian standards and regulations and incorporation of US programs such as the EPA's Target Finder. Green Globes also awards points for the use of life cycle assessment methods in product selection, although it does not specify how to apply such methods. It is very likely that Green Globes presence on the American scene has had a beneficial impact on LEED, perhaps prompting it to improve its rating system and release LEED 2009 Version 3 and LEED v4. It is also important to recognize that Green Globes can attract a significant following that for various reasons are alienated by LEED certifications costs and complexity. This must be good for the green building industry and the environment.

Green Globes supporters tried to block the introduction of LEED into Canada but lost a close vote in a committee of the Royal Architectural Institute of Canada that led in 2003 the creation of the Canada Green Building Council (CaGBC). Alex Zimmerman, the first president of CaGBC, has levied some criticisms of Green Globes, noting that in Canada Jiri Skopek, president of ECD Energy and Environment Canada has been the primary developer of Green Globes and in the past was its sole certifier. Zimmerman also says, "While there are more certifiers now, it is not clear who they are, how they were chosen, or who they are answerable to." GBI responded to this criticism in the United States by training a network of independent certifiers to verify Green Globes ratings and who have access to the report generated by the Green Globes website, as well as other relevant information such as the project drawings, results of an energy simulation, specifications, and commissioning plan. Thomas Mueller, President and CEO of the CaGBC, says "As the voice of the green building industry in Canada, we are now focusing on the federal government to leverage green

building as an actionable solution to reaching Canada's climate change commitments. The upward trend of Gold and Platinum level certifications is a positive sign that the industry is capable and ready to achieve more ambitious performance targets in new and existing buildings. However, we must engage more building owners to take action through energy benchmarking and verified performance improvements."

Advantages of the Green Globes Rating/Certification System is that it is marketed as an economical, practical, and convenient methodology for obtaining comprehensive environmental and sustainability certification for new or existing commercial buildings. It provides a complete, integrated system that has been developed to enable design teams and property managers to focus their resources on the processes of actual environmental improvement of facilities and operations, rather than on costly, cumbersome, and lengthy certification and rating processes.

Among the other advantages to using Green Globes Rating/Certification Systems are:

- A low registration fee is required to have projects evaluated and informally self-assessed.
- Consultants are not necessary for the certification process—thereby reducing costs.
- Certification requirements are generally less cumbersome and complex than other rating/certification systems.
- Online web tools provide a convenient, proven, and effective way to complete the assessment process.
- The entire certification process is fairly rapid, with minimal waiting for final rating/certification.
- The estimated rating number of Green Globes that will be achieved is largely known in advance of the decision to pursue certification because the self-assessed score is available to users.
- Upfront commitment to a lengthy and costly rating/certification process is not required.

Finally, as previously mentioned, Green Globes, along with LEED, are the only two green building certification programs recognized by the US federal government. In fact, the General Services Administration (GSA) has recently said that the Green Globes standard meets more federal government requirements than any other program. Following the lead of GSA, the Defense Department also named Green Globes as an approved certification program. In addition, currently more than 30 states recognize Green Globes or accept it as equivalent to LEED.



2.5 GREEN RATING STANDARDS USED WORLDWIDE

Historically, the first environmental certification system was created in the United Kingdom in 1990, called the Building Research Establishment Environmental Assessment Method (BREEAM). This was followed in the United States by the USGBC's introduction in 1998 of the LEED green building rating system, based substantially on the BREEAM rating system. The Green Globes rating system is an adaption of the Canadian version of BREEAM and was released in the United States by the Green Building Initiative (GBI) in 2005. There are numerous other rating systems used in countries around the world, each with its pros and cons depending on the type of certification targeted for a specific building. However, LEED followed by Green Globes are currently the most widely applied systems for commercial construction in the United States.

Today, USGBC has rating systems for new construction, existing buildings, core and shell, commercial interiors, schools, retail, homes, healthcare, and neighborhood development, whereas the GBI has a rating system for commercial buildings which includes new construction buildings and existing buildings. The GBI also partners with the NAHB to promote green homes.

Rating and certification systems are required to verify the sustainability and “greenness” of buildings in the market. They basically inform us how ecofriendly and environmentally sound a building is, and delineate to what extent green components have been incorporated and identify the sustainable principles and practices that have been employed. Moreover, rating or certifying a green building helps remove some of the subjectivity that often surrounds buildings that have not been certified. Moreover, rating a green building makes a property more marketable by informing tenants and the public about the environmental benefits of a property and also discloses the additional innovation and effort that the owner has invested to achieve a high-performance building. Certification also reveals the level of sustainability achieved.

A holistic approach to design translates into a strategic integration of mechanical, electrical, and materials systems. Such an approach often creates substantial efficiencies, the complexities of which are not always apparent. Rating a green building identifies these differences objectively, and quantifies their contribution to energy and resource efficiency. The fact that rating systems typically require independent third-party testing of the various elements means there is less risk that these systems will not perform as

predicted. Furthermore, formally rating or certifying a building dramatically reduces the risk of the possibility of falsely marketing a building under the perception that it is green when in fact it is not. Below are examples of some of the more widely used rating systems in the United States:

LEED: This rating system was developed by the US Green Building Council (USGBC) and continues to be the most widely applied rating system in the United States for commercial buildings. The LEED system consists of several rating categories, applicable to different points in a building's life cycle and is discussed in other parts of this chapter. The GSA and other municipalities and government departments, as well as an increasing number of private investors and owners have instituted policies requiring LEED certification for new construction projects. The USGBC also holds an annual green building conference—Greenbuild, which helps promote the green building industry.

Green Globes: This rating system is an interactive, web-based commercial green building assessment protocol offered by the Green Building Initiative (GBI) and is discussed in the following section of this Chapter. It offers immediate feedback on the building's strengths and weaknesses and automatically generates links to engineering, design, and product sources. The system basically evaluates buildings in seven areas (www.thegbi.org/greenglobes). Green Globes continues to gain traction. Indeed, the parent company of Green Globes was recently acquired by a highly respected, established company: Jones Lang LaSalle.

ENERGY STAR: This is a joint government-backed program of the Environmental Protection Agency (EPA) and the US Department of Energy (www.energystar.gov). Since its inception in 1992, the program has overcome many market barriers and helped revolutionize the marketplace for cost-effective, energy-efficient products and services. It has now transformed into an international standard for energy-efficient consumer products and has been adopted by numerous countries including the European Union, Canada, Japan, and Australia. The mission of the program is to help businesses and individuals protect the environment through superior energy efficiency. The program is also designed for existing buildings, consisting of an Energy Performance Rating System that is free with an online tool that focuses on energy performance. With ENERGY STAR, impacts of other factors such as indoor air quality, materials, or water conservation are not taken into consideration. The program has grown to encompass

more than 60 product categories for the home and workplace, new homes, and superior energy management within organizations. The system basically compares the energy performance of a specific building to that of a national stock of similar buildings. The data entered into the ENERGY STAR Portfolio Manager tool will model energy consumption based on a building's size, occupancy, climate, and space type. A minimum of 1 year's utility information input is required before the property can be assigned a rating (from 1 to 100). To apply for and receive the ENERGY STAR label, buildings must acquire a score of 75 or more.

Other Green Building Standards Worldwide: Many countries throughout the world continue to develop their own standards of energy efficiency for buildings. Only a small number of these systems are currently being applied in the United States, but they may still prove influential in the emerging green building industry. Examples include BREEAM in the United Kingdom, Green Star in Australia, and BOMA Go Green Plus in Canada. Below are examples of building environmental assessment tools currently being used by different countries around the world.

Australia: The Green Building Council of Australia (GBCA) was launched in 2002 and is a national, not-for-profit organization that is committed to developing a sustainable property industry for Australia by encouraging the adoption of green building practices. The GBCA is supported by both industry and governments across the country. The GBCA developed a green building standard known as the Green Star environmental rating system which is accepted as the Australian industry standard for green buildings. The system is essentially a comprehensive, national, voluntary environmental rating system that evaluates the environmental design and construction of buildings in Australia. According to the GBCA website, its main objectives are “to drive the transition of the Australian property industry towards sustainability by promoting green building programs, technologies, design practices and operations as well as the integration of green building initiatives into mainstream design, construction and operation of buildings.” It has now been mandated in three states as a minimum for Government office accommodation. The Green Star environmental rating tools for buildings benchmark the potential of buildings based on nine environmental impact categories. There are other standards that are used such as Energy-Efficiency Rating (EER) and National Australian Built Environment Rating System (NABERS) which is a government initiative to measure and compare the environmental performance of Australian buildings. NABERS is a

performance-based rating system for existing buildings. It now incorporates the Australian Building Greenhouse Rating (ABGR) and has been renamed NABERS Energy for offices. Of note, the GBCA has recently forged a new partnership with the Australian Supply Chain Sustainability School to fast-track the industry's green skills.

Canada: LEEDS and Green Globes are the two most widely applied green rating systems in Canada. The CaGBC which was established in December 2002 acquired an exclusive license in 2003 from the USGBC to adapt the LEED rating system to Canadian circumstances. The Canadian LEED for Homes rating system was released on March 03, 2009. Canada has also implemented the "R-2000" program which is a made-in-Canada home building technology to promote construction that goes beyond their building code to increase energy efficiency and promote sustainability. An optional feature of the R-2000 home program is the EnerGuide rating service which is available across Canada and which allows home builders and home buyers to measure and rate the performance of their homes and confirm that those specifications and standards have been met.

The R-2000 Program consists of a collaboration between the Canadian Home Builders' Association (CHBA) and the Office of Energy Efficiency (OEE) of Natural Resources Canada (NRCan). For close to three decades, the two partners have worked together on the components that make up the R-2000 Program. Regional initiatives based on R-2000 include ENERGY STAR for New Homes, Built Green, Novoclimat, GreenHome, Power Smart for New Homes, and GreenHouse. In March 2006, Canada's first green building point of service, Light House Sustainable Building Centre, opened in Vancouver, BC which is funded by Canadian government departments and businesses to help implement green building practices.

China: China reportedly has the biggest construction volume in the world; nearly half of the world's new building construction is now estimated to be in China. Yet the green building industry is still in its infancy in China, and green building demand continues to be driven mainly by multinational companies. There are currently two sets of national building energy standards being applied in China (one for public buildings and another for residential buildings). China has in place mandatory building energy standards but which are narrow in their scope and currently lack a strong regulatory framework to incorporate energy-efficient standards in construction. Moreover, MoC enforcement remains problematic, and the central government put in place a building inspection program to monitor the

implementation of building energy efficiency. Design institutions, developers, and construction companies will lose their licenses or certificates under this program if they do not comply with the regulations. China also recently launched a new green building standard, which is meant to complement better known labels like BREEAM (United Kingdom) and LEED, which are presently only used in office buildings for multinationals or upscale apartments.

Standards and Ratings: Multinational companies have taken the lead to promote green building construction in China by pursuing more stringent LEED certification. The trend was initiated by Plantronics, a California-based electronics company, when it achieved a LEED gold certification for its new manufacturing and design center in Suzhou. This was followed by Nokia who received its first LEED gold certification globally for the Nokia China Campus in Beijing. Other big names followed including Siemens and BHP Billiton.

An MOU on building energy efficiency was signed between the United States and China in which the United States pledged \$15 million for a joint US–China clean energy research center. The MoC also recently introduced the “Evaluation Standard for Green Building” (GB/T 50378-2006), which resembles in structure and rating process of the USGBC’s LEED (which is also being used). The building energy consumption data will be collected by MoC and will be used to assess building performance; a three-star Green Building certificate will be awarded to qualified buildings. Green Olympic Building Assessment System (GOBAS) is another green building rating system that was initially based on Japan’s Comprehensive Assessment System for Building Environment Efficiency (CASBEE). High-performance building projects are being supported both by the government and the private business sector. The World Green Building Council (WGPC), a Sustainable Buildings and Climate Initiative Member (SBCI) has assisted the MoC in China to establish the China Green Building Council. This Council is also supported by the USGBC.

France: The French President, Nicolas Sarkozy instigated a “Le Grenelle de l’Environnement” (“Grenelle Environment Round Table”) to define the key points of public policy on ecological and sustainable development issues for the coming 5 years and to find ways to redefine France’s environment policy. The process led to a set of recommendations released at the end of October 2007 and which were put to the French parliament in early 2008. Six working groups were formed composed of representatives of the central government, local governments, employer organizations, and trade unions

and NGOs to debate and address various themes such as climate change, energy (the building sector consumes 42.5% and transports 31% of total French energy) biodiversity, natural resources, health and the environment, production and consumption, democracy and governance, and competitiveness, development patterns, and environmental employment. Within the framework of the “Grenelle de l’environnement,” the performance acceleration is designed to meet the following objectives for tertiary buildings:

- Low-consumption buildings (BBC) by 2010 with minimum requirements concerning the levels of renewable energy and CO₂ absorption materials by 2012.
- Passive new buildings (BEPAS) or Positive buildings (BEPOS) by 2020.
- Labels for refurbishment of existing BBC buildings.

All these developments match with the European and international regulations and frameworks.

These developments are intended to match with European and international regulations and frameworks. Additionally, two property companies, AXA Real Estate Investment Management and ING Real Estate recently set up a rival rating system in the United Kingdom called Green Rating which allows owners to compare properties’ sustainability across Europe. It was recently launched in France, Spain, Italy, the Netherlands, and Germany. In 2010, it is expected to be launched in the United States and Japan. The advantage of Green Rating is that it is an assessment of the energy efficiency of a building and looks at both the building materials and the waste generated by the building. The audit process has been tested on 50 sites in Europe and is broken into four stages:

- Data collection: The site technical manager collects data in six areas: energy use, carbon emissions, water use, waste, proximity to transport links, and the health of the employees.
- On-site survey and interview with the site manager or owner: A Green Rating assessor inspects the building and the equipment.
- Energy modeling: A model is created to see how energy is used across areas of the building.
- Recommendations: Green Rating advises how improvements could be made. An additional audit could then be carried out a year or two after the first.

Since January 01, 2013, all new buildings or parts must meet the requirements of the RT 2012. It is the aim to limit the consumption of primary energy housing 50 kWh/m² on an average through bioclimatic design and

energy-efficient buildings. These developments are intended to match with European and international regulations and frameworks.

Germany: In January 2009 the first German standard for the new certificates was developed for sustainable buildings by the DGNB (Deutsche Gesellschaft für nachhaltiges Bauen e.V. - German Sustainable Building Council) and the BMVBS (Bundesministeriums für Verkehr, Bau und Stadtentwicklung—Federal Ministry of Transport, Building and Urban Affairs) to be used as a tool for the planning and evaluation of buildings. The DGNB is a clear and easy to understand rating system and covers all relevant topics of sustainable construction. There are six subjects that affect the evaluation: ecology, economy, social-cultural and functional topics, techniques, processes, and location. Outstanding buildings can achieve awards in the categories bronze, silver, and gold.

There are a number of German organizations that employ green building techniques such as:

- The Solarsiedlung (Solar Village) in Freiburg, Germany, which features energy-plus houses.
- The Vauban development, also in Freiburg.
- Houses designed by Baufritz, incorporating passive solar design, heavily insulated walls, triple-glaze doors and windows, nontoxic paints and finishes, summer shading, heat recovery ventilation, and gray water treatment systems.
- The new Reichstag building in Berlin, which produces its own energy.

India: GRIHA, a rating system for green buildings developed by The Energy and Resources Institute (TERI) of India and which plays a key role in developing green building awareness and strategies in the country. GRIHA was adopted and endorsed by the Government of India as the National Green Building Rating System for the country, and measures are being taken to spread awareness about this rating system, and TERI signed an MOU with the Union Ministry of New and Renewable Energy to this effect. The aim of GRIHA is to ensure that all types of buildings become green buildings. One of the strengths of GRIHA is that it puts great emphasis on local and traditional construction knowledge and even rates nonair conditioned buildings as green.

GRIHA uses 32 criteria to evaluate and rate buildings, totaling a maximum of 100 points. A building must score at least 50 to apply to for certification. Preserving landscape during construction; soil conservation after

construction; and reducing air pollution are some of the qualifying criteria. Buildings will also need to quantify energy consumption in absolute terms and not percentages alone.

The Confederation of Indian Industry (CII) is also playing an active role in promoting sustainability in the Indian construction sector. The CII is the central pillar of the IGBC. The IGBC in turn is licensed by the LEED Green Building Standard from the USGBC and is currently responsible for certifying LEED New Construction and LEED Core and Shell buildings in India. All other projects are certified through the USGBC. According to the IGBC, “The building sector in India is growing at a rapid pace and contributing immensely to the growth of the economy. This augurs well for the country and now there is an imminent need to introduce green concepts and techniques in this sector, which can aid growth in a sustainable manner.” There are many energy-efficient buildings in India, situated in a variety of climatic zones (Fig. 2.10).

In June 2007 the Indian Bureau of Energy Efficiency (BEE) launched the Energy Conservation Building Code (ECBC), which specifies the energy performance requirements for all commercial buildings that are to be constructed in India. The ECBC is set for energy efficiency standards for design and construction with any building of minimum conditioned area of 1000 square meters (10,764 sq. ft.) and a connected demand of power of 500 KW or 600 KVA. On February 25, 2009 the BEE launched a five star rating scheme for office buildings operated only in the day time in three climatic zones—composite; hot and dry; and warm and humid. It is worth



Figure 2.10 The Sohrabji Godrej Green Business Centre in Hyderabad, India. This was the first Platinum-rated green building under the LEED rating system, outside the United States, boasting Energy Savings of 63%. *Source: Confederation of Indian Industry.*

noting that the Green Business Certification, Inc. (GBCI) and the Bureau of Energy Efficiency (BEE) Ministry of Power, Government of India recently signed a landmark agreement with the goal of spurring energy efficiency progress in building sectors. The agreement recognizes the many benefits of green building through improved energy intensity, environmental, and economic performance.

Israel: A green building standard, approved in November 2005, which is awarded to new or renovated residential and office buildings that comply with the requisite requirements and criteria. This is a voluntary new standard for “Buildings with Reduced Environmental Impact” SI-5281. The standard is comprised of four sections covering: energy, land, water, wastewater, drainage, and other environmentally related elements. A building which meets the prerequisites in each chapter and accumulates the minimum number of credit points in every environment-related sphere is eligible for “green building” certification. The standard is based on a point rating system. Thus, a cumulative score of 55–75 points entitles a building to a “green building” label, whereas a cumulative score of more than 75 points allows it to be certified as an “outstanding green building.” Together with complementary standards 5282-1, 5282-2 for energy analysis, and 1738 for sustainable products, it provides a system for evaluating environmental sustainability of buildings. In 2011 Israel’s main green building standard—SI 5281: Sustainable Buildings—was upgraded to international standards. The other two noteworthy green building standards in Israel are: SI 5282: Energy Rating of Buildings and SI 1045: Thermal Insulation of Buildings. As of July 2013, SI 5281 was undergoing another revision. Changes to be made are expected to include expanding it to industrial buildings, neighborhoods, campuses, and more. In 2014, there were 140 buildings built in accordance with green building standards, either by Forum 15 municipalities or by private companies/contractors. The standard is to be reevaluated every 2 years to ensure that it is up to date and includes the latest knowledge on the subject. It should be noted that compliance with all three Israeli green building standards remains voluntary.

United States Green Building Council’s LEED rating system has also been implemented on several building projects in Israel, and there is a strong industry drive to introduce an Israeli version of LEED in the near future. The reason is that due to different climatic conditions and building construction methods in Israel, the LEED rating system cannot be adopted as is. In [Fig. 2.11](#), is a photo of Israeli’s first Platinum-rated building.



Figure 2.11 The Porter School of Environmental studies is Israel's first LEED Platinum Building. Construction broke ground in December, 2011 on what is called Israel's greenest building. It is conveniently located within walking distance of public transportation—Tel Aviv University Railway Station and a bus terminal. The building's sustainable features include solar PV panels, wastewater recycling, a green roof, and a cage-like "Ecowall" with solar tubes that will provide heat during the winter while during the summer the same wall will provide shading to keep the interior cool. Also, there are small terraces or labs that are built into this EcoWall.

Japan: A joint industrial/government/academic project was created in 2001 with the support of the Housing Bureau, Ministry of Land, Infrastructure, Transport and Tourism (MLIT). This led to the creation of the Japan GreenBuild Council (JaGBC)/Japan Sustainable Building Consortium (JSBC), which in turn created the CASBEE system. The CASBEE system was developed according to the following principals:

- Structured in a manner to award high assessments to superior buildings, thereby enhancing incentives to designers and other stakeholders.
- To be applicable to buildings in a wide range of applications.
- To be as simple as possible.
- To take into consideration issues and problems peculiar to Japan and Asia.

CASBEE certification is currently available for New Construction, Existing Building, Renovation, Urban Development, Heat Island, Urban Area plus Buildings and detailed home.

The CASBEE system is composed of four assessment tools that are intended to correspond to a building's life cycle. The collective name for these four tools and the expanded tools for specific purposes is the "CASBEE Family" and are designed to serve at each stage of the design process. Each tool is designed for a separate purpose and target user, with



Figure 2.12 The PTM Green Energy Office Building (GEO Building) is Malaysia's first GBI-certified green building and is designed as an administration-cum-research office for Pusat Tenaga Malaysia (Malaysia Energy Centre). The GEO building is built on a 5-acre site in Seksyen 9, Bandar Baru Bangi, Selangor, Malaysia. It is among the first Malaysian Government office buildings whose design is based on green concepts and is environmentally friendly. *Source: PTM-GreenBuildingIndex.*

the purpose of accommodating a wide range of uses (offices, schools, apartments, etc.) in the buildings evaluation process. Furthermore, the process of obtaining CASBEE certification differs from LEED in that the LEED certification process starts at the beginning of the design process, with review and comments taking place throughout the design and construction of a project. Although CASBEE's latest version for New Construction ranking uses predesign tools, certification consists primarily of site visits once the building is completed. Of note, the 2014 editions of CASBEE tools were released in February 2015.

Malaysia: The main organization promoting green practices and building techniques is the Standards and Industrial Research Institute of Malaysia (SIRIM). However, Malaysia has now put in place a new rating system called Green Building index (GBI) for commercial and residential properties. The GBI was developed in 2009 by Pertubuhan Akitek Malaysia (PAM) and the Association of Consulting Engineers Malaysia (ACEM). It is a profession-driven initiative to lead the Malaysian property industry toward becoming more environment friendly (Fig. 2.12). The GBI's purpose is to promote sustainability in the built environment and raise awareness among those in the development, construction, and design industry, as well as the general public about environmental issues and the importance of green technology in buildings. The GBI rating system provides an opportunity for developers to design and construct sustainable buildings that can provide increased

energy savings, water savings, a healthier indoor environment, better connectivity to public transport, and the adoption of material recycling and greenery for their projects.

The Green Building Index (GBI) has six key criteria, they are: energy efficiency, IEQ, sustainable site and management, MR, and water efficiency. Based on the scores achieved, commercial buildings will be rated and then certified as silver, gold, or platinum. Final award is presented one year after the building is first occupied. Buildings are also required to be reassessed every 3 years to maintain their GBI rating by ensuring that the buildings are well maintained. Internationally, there are other green rating systems such as LEED (the United States and Canada), ENERGY STAR (United States), BREEAM (Britain), CASBEE (Japan), Green Star, and NABERS (Australia).

Mexico: The Mexico Green Building Council (CMES) is the principal organization dedicated to promotion of best practices that improve the environmental performance of buildings and fostering sustainable building technology and policy. It is an independent nonprofit, nongovernmental organization that works from within the construction industry to promote a broad-based transition toward sustainability. Its stated mission is to promote sustainable development through the realization and construction of a superior built environment. Mexico is also setting trends relating to health and wellness. The WELL Building Standard, the first building standard to focus on human health and well-being which was launched in October 2014, has started making inroads in Mexico as the first projects begin pursuing WELL Certification in the region. Attaining LEED certification is important for achieving the best possible results for environmental sustainability, and WELL maximizes the potential for supporting human health and wellness.

Under a new partnership agreement, ASHRAE and the CMES will work together to promote buildings that are healthful, environmentally responsible, comfortable and productive, and profitable. The agreement is part of ASHRAE's new strategy for a global environment, committing the Society to working with organizations with shared interests and values.

Mexico City's government is promoting the creation of a standard certification program for green buildings, and the City's Minister of the Environment announced that certified green buildings will be able to obtain up to 25% discount on property taxes. The Green Building Certification Program will have three levels of certification: lowest rate from 21 to 50

points; efficiency level goes from 51 to 80 points; and excellence level from 81 to 100 points. The higher the level, the greater the level of property tax discounts. At the beginning the tax discount will be a voluntary scheme but is intended to become mandatory in the future.

New Zealand: In July 2005 the New Zealand Green Building Council (NZGBC) was formed; this is a not-for-profit, industry organization dedicated to accelerating the development and adoption of market-based green building practices. In 2006/2007, several major milestones were achieved including the NZGBC becoming a member of the World GBC and the launching of the Green Star NZ (Office Design Tool and welcoming of member companies). Green Star is a comprehensive, national, voluntary environmental rating scheme that evaluates environmental attributes and performance of New Zealand's buildings using a suit of rating tool kits developed to be applicable to each building type and function. Green Star was developed by the NZGBC in partnership with the building industry. Likewise, for more than 7 years, Green Star has been successfully influencing and improving New Zealand's commercial built environment. However, it is important to continuously refresh and update the tool to ensure that Green Star is up to date and meeting industry's needs. Although there have been incremental improvements, this is the first major review of Green Star since 2009. Indeed, over the past few months, NZGBC's technical team has been working alongside professionals and developers and the building industry to review four key categories: Innovation, Energy, Water, and Materials.

South Africa: The Green Building Council (GBC) of South Africa was launched in 2007; its stated mission is, "To promote, encourage and facilitate green building in the South African property and construction industry through market-based solutions, by:

- Promoting the practice of green building in the commercial property industry
- Facilitating the implementation of green building practice by acting as a **resource center**,
- Enabling the objective measurement of green building practices by developing and operating a green building rating system, and
- Improving the knowledge and skills base of green building in the industry by enabling and offering training and education."

The South African GBC has since developed a Green Star SA rating tools, based on the GBCA tools, to provide the property industry with an

objective measurement tool for green/sustainable buildings and to recognize and reward environmental leadership. Each Green Star SA rating tool reflects a different market sector (e.g., office, retail, multiunit residential, etc.). Green Star SA - Office was the first tool developed and which was released in final form (version 1) at the GBC of South Africa Convention & Exhibition '08 in November 2008. South Africa is in the process of incorporating an energy standard SANS 204 which aims to provide energy-saving practices as a basic standard in the South African context. Green Building Media which was launched 2007 has also played an instrumental role in green building in South Africa. Also, the Green Building Council South Africa (GBCSA) has recently announced that it intends to play a bigger role in creating greener homes using the EDGE (Excellence in Design for Greater Efficiencies) residential green building certification scheme.

United Arab Emirates: The LEED has been commonly used in the UAE, mostly in Dubai; taking advantage of its international, national, regional, and local applicability to create buildings that alleviate greenhouse gas emissions and enhance other sustainability actions. On the other hand, the Abu Dhabi emirate applies the Estidama Pearl Rating System, as a regulation and a sustainable development framework, whereas the Dubai emirate applies its own Green Building Regulations and Specifications. Policies and regulations are important tools to support the UAE's vision for a Green Economy if it is to reach its sustainability objectives. Within Abu Dhabi, there exists a wide-ranging framework of policies, planning guidelines, codes, and regulations to ensure the effective implementation of the Plan 2030 vision. In 2006 the Emirates Green Building Council (EmiratesGBC) was created, with the primary goal of advancing green building principles for protecting the environment and ensuring sustainability in the United Arab Emirates.

One of the UAE's greenest buildings is the Dubai Electricity and Water Authority (DEWA) Headquarters which received a LEED Platinum certification (Fig. 2.13). The primary goal of this project was to assist the Dubai Chamber in emphasizing its achievement in the field of green building and sustainability and to inspire others to follow suit. DEWA says it aims to make Dubai a smart, integrated, and connected city with high-tech energy and water infrastructure ahead of Expo (2020). Accordingly, Dewa recently launched the first electric vehicle charging station in Dubai at Dewa Headquarters and has recently registered the first "green charger" user for electric vehicles. This new initiative is in support of the Smart



Figure 2.13 Photo depicting the Dubai Electricity and Water Authority (DEWA) Headquarters in the UAE which received a LEED Platinum certification. DEWA's green features help the building reduce consumption of energy by 66% and water by 48%. Additionally, 36% of construction material used was recycled content. DEWA was founded on January 01, 1992 by Sheikh Maktoum bin Rashid Al Maktoum. After using conventional gas-fired power plants since it was founded, DEWA recently added solar power to its energy mix.

Dubai initiative launched by His Highness Sheikh Mohammed bin Rashid Al Maktoum, Prime Minister of the UAE and Ruler of Dubai, to transform Dubai into the smartest city in the world.

Dubai's Chamber has over 150,000 members and is a regional leader in Corporate Social Responsibility and takes great efforts to enhance the sustainability of its own operations while encouraging others to do the same. Reapplying LEED EBOM postrenovation, to the Platinum level, was imperative to be able to independently verify the results of its head office's green retrofit and prove that existing buildings in the region can be upgraded to the highest green building standards.

United Kingdom: The Association for Environment Conscious Building (AECB) was founded in 1989 and incorporated in January 2005 to increase awareness within the construction industry of the necessity to respect the environment and to promote sustainable building in the United Kingdom. The AECB is now under the Energy Performance of Building Directive (EPBD), Europe has made a mandatory energy certification since January 04, 2009. A key part of this legislation is that the EPBD requires all EU countries to enhance their building regulations and to introduce energy certification schemes for buildings. All countries are also required to have inspections of boilers and air conditioners.

A mandatory certificate called the Building Energy Rating system (BER) and a certification Energy Performance Certificate (EPC) is needed by all buildings that measure more than 1000 square meters (approximately 10,765 sq. ft.) in all the European nations. Furthermore, when buying or selling a home, it is now law to have a certificate. Certificates are also required on construction of new homes and for rented homes the first time the property is let after October 01, 2008. The certificate records how energy efficient a property is as a building and provides A-G ratings. These are similar to the labels now provided with domestic appliances such as refrigerators and washing machines.

The UK Green Building Council (UK-GBC) also called for the introduction of a Code for Sustainable Buildings in March 2009 to cover all nondomestic buildings, both new and existing. Although the Code for Sustainable Buildings is owned by the government, it is developed, managed, and implemented by industry and covers refurbishment as well as new construction. Furthermore, from September 01, 2009, the Welsh Assembly Government planning policy put in place a national standard for sustainability for most new buildings proposed in Wales.

According to the BREEAM (BRE Environmental Assessment Method) website, the BREEAM assessment process was created in 1990 as a tool to measure the sustainability of new nondomestic buildings in the United Kingdom with the first two versions covering offices and homes. BREEAM is the leading and widely used environmental assessment method in the United Kingdom for buildings, setting the standard for best practice in sustainable design and a measure used to describe a building's environmental performance. It has been updated regularly in line with UK building regulations and underwent a significant facelift on August 01, 2008, called BREEAM 2008. Credits are awarded in each of the areas shown below according to specific performance:

- Management
- Health and Wellbeing
- Energy
- Transport
- Water
- Material and Waste
- Land Use and Ecology
- Pollution

A set of environmental weightings then enables the credits to be added together to produce a single overall score. This allows a building to be rated

on a scale of: Pass, Good, Very Good, Excellent or Outstanding; this is followed by a certificate being awarded to the development.

Some of the dramatic changes to BREEAM 2008 were in response to an evolving and changing construction industry and public agenda, and include:

- Introduction of mandatory credits
- Two stage assessment process introduced (Design stage and PostConstruction stage)
- Additional rating level added (BREEAM Outstanding)
- Environmental weightings modified
- CO₂ emissions benchmarks set to align with the new Environmental Performance Certificate (EPC)
- Changes to certain specific credits
- Updated Green Guide Ratings which will be available online
- Introduction of BREEAM Healthcare and BREEAM Further Education
- Shell only assessments

On 1st of June, BRE launched its new standard for the overseas market—BREEAM International New Construction 2013—which is to be used to assess commercial and residential buildings worldwide. The standard combines two previous international standards, BREEAM Europe Commercial and BREEAM International Bespoke and is the first BREEAM scheme for the certification of residential buildings outside the United Kingdom.

According to the BRE Group, BREEAM International New Construction 2013:

- sets new benchmarks for energy efficiency and operational carbon emissions, including rewards for “carbon negative” buildings
- introduces new requirements on sustainable procurement and postconstruction operational after-care
- adds new reporting requirements on building life cycle CO₂ emissions, construction and operational water consumption, construction waste and VOC emissions
- allows for adaption to the local environment
- introduces credits for appointing a BREEAM-Accredited Professional and credits for a building technology, feature, design or construction method or process recognized as “innovative”

We now have the latest changes in BREEAM 2016 which blend stricter environmental requirements with a simplified certification process. The latest BREEAM scheme officially became available on 21 March and as of March 28, 2016 completely replaces the earlier version from 2013, which

is no longer valid. The update includes certification criteria for new building types such as hotels, schools, and universities, and addresses some of the challenges faced by residential buildings, as more and more properties of this type are turning to sustainable building practices.

In the updated 2016 BREEAM, management credits were also reorganized to allow a better alignment to the construction process; the core & shell certification module for new buildings likewise was redesigned and simplified, to supplement the BREEAM fit-out certification scheme issued in 2015. Energy represents a major touch point for the modernized scheme, as the reference standard for energy efficiency was updated and local energy performance standards are now applicable. It should be noted that BREEAM is considered to be the preferred scheme for a number of the national GBCs across Europe, including the Netherlands, Norway, and others.

ESOS has recently been introduced to facilitate the United Kingdom meeting its requirements under the EU Energy Efficiency Directive and is expected to affect more than 9000 of the largest companies in the United Kingdom. The scheme mandates that these companies undertake obligatory assessments looking at energy use and energy efficiency opportunities at least once in every 4 years. ESOS compliant energy audits are employed to assess total energy consumption (using verifiable energy data) over a consecutive 12-month period known as the reference period. What many miss in the detail, is that the reference period must overlap with the qualification date and end before December 05, 2015.

United States: There are numerous sustainable design organizations and programs in place within the United States. The most widely used rating system is the USGBC which promotes sustainability in how buildings are designed, built, and operated and is best known for the development of the LEED rating system and Greenbuild, a green building conference well known for its promotion of the green building industry and environmental issues.

Today, LEED is adopted in more than 150 countries and territories worldwide and has 76 chapters and 197,000 LEED professionals strong. It also has 12,870 member organizations from all sectors of the building industry; it works to promote buildings that are environmentally responsible, profitable, and healthy places to live and work. The USGBC through its GBCI offers industry professionals an opportunity to receive accreditation as green building professionals. In June 2009, LEED had a complete

overhaul of its rating system and introduced a new version (LEED v3), with a two-tier system. This was followed by its latest version, LEED v4.

The NAHB is a trade association representing home builders, remodelers, and suppliers to the industry; it has formed a voluntary residential green building program called NAHBGreen (www.nahbgreen.org). This program incorporates an online scoring tool, national certification, industry education, and training for local verifiers. The online scoring tool is free to both builders and home owners. The NAHB announced in August 2009 that the number of home builders, remodelers, and other members of the real estate and construction industry who hold the Certified Green Professional (CGP) educational designation now tops 4000. According to NAHB, its *New American Home 2016* is “America’s premier show home! For 2016, the 33rd home in the TNAH series, the 5050 sq. ft. home incorporates the latest green and sustainable building materials, products, energy efficiencies, and construction methods to reduce its impact on the environment and provide the highest quality of life for the occupants. The 2016 New American Home offers a real-world demonstration of the latest concepts in architecture design, construction techniques, new products, and lifestyle trends in the marketplace today!” (Fig. 2.14).

The GBI is a nonprofit network of building industry leaders working to mainstream building approaches that are environmentally progressive but is also practical and affordable for builders to implement. The GBI has introduced a web-based rating tool called Green Globes, which is a green management tool that includes an assessment protocol and a rating system and



Figure 2.14 Photo showing NAHB documenting the New American Home 2016 as it goes through each stage of the construction process. This image reflects America’s premier show home!

guide for integrating environmentally friendly design into both new and existing commercial buildings. As previously discussed in this chapter, many states have now formally recognized the GBI's Green Globes environmental assessment and rating system in legislation. These include: New Jersey, Arkansas, Connecticut, Hawaii, Maryland, Minnesota, North Carolina, Oklahoma, Pennsylvania, South Carolina, Kentucky, Illinois, and Wisconsin.

ENERGY STAR is a program established by the U.S. EPA and U.S. Department of Energy that focuses on creating energy-efficient homes and buildings designed to protect the environment while at the same time saving money for home owners and businesses. The system also rates commercial buildings for energy efficiency and provides ENERGY STAR qualifications for new homes that must meet a series of energy efficiency guidelines established by the EPA. ENERGY STAR has recently released its Most Efficient 2016 Criteria which is a new program element to identify and advance highly efficient products in the marketplace. This program is designed to identify the most efficient products among those that qualify for the ENERGY STAR in particular product categories.



The Green Design and Construction Process



3.1 GENERAL OVERVIEW

Gone are the days of green building being a niche market. Ecofriendly construction or Building green no longer focuses only on environmental factors and considerations, but it also takes into account how the environment integrates with other factors such as cost, schedule, operations, maintenance, tenant/employee, and other considerations. Furthermore, it is important to understand that no matter how good building green may be for the environment, not many developers would be willing to jump on the “green” bandwagon if the alternative is cheaper. This is particularly true in the construction industry where, for commercial buildings, traditional methods could prove to be significantly cheaper. Research clearly shows that people in contemporary societies such as the United States and Europe generally spend most of their time inside buildings and we apparently take for granted the shelter, protection, and comfort that our buildings provide. Unfortunately, we rarely give sufficient thought to the systems that allow us to enjoy these services unless we are faced with an unfortunate power interruption or some other problem. Furthermore, not many people fully comprehend the full extent of the environmental consequences that allow us to maintain indoor comfort levels. This may be partly because modern buildings continue to increase in complexity. Likewise, buildings’ functions continue to change and become increasingly costly to build and maintain, as well as requiring constant adjustment to function effectively over their life cycle. And while sustainable design strategies may normally cost no more than conventional building techniques, the real goal of interdependence between strategies, known as holistic design, makes determining the true cost often difficult to assess. Furthermore, it is frequently found that the returns on sustainable design are generally measured by numerous intangibles, such as worker productivity, health, and resource economy. But for many building owners, developers, and designers it is more likely that determinations on sustainable design strategies will be made based on initial construction costs or by a quick return on investment rather than

on the positive returns based on a building's lifecycle and the many positive attributes of a green building.

While sustainability and green building construction continues to advance, nevertheless, the increasing presence of large numbers of conventionally designed and constructed buildings on the market today is fortifying their negative impact on the environment as well as on occupant health and productivity. Additionally, these buildings have become increasingly expensive to operate and maintain in a highly competitive market. Owners and developers as well as the construction industry have finally come to realize that their contribution to excessive resource consumption, waste generation, and pollution is unacceptable and must be addressed. Reducing negative impacts on our environment and establishing new ecofriendly goals as well as adopting guidelines and codes that facilitate the development of green/sustainable buildings as proposed by the USGBC, Green Globes, and similar organizations must be a priority for this generation. Of note, the International Green Construction Code (IgCC), which was recently approved after considerable research and development, is another sign of the seriousness that the federal government is taking regarding the negative impact of conventional building construction on the environment. The IgCC was established to aid in the construction of sustainable buildings in the business and residential sectors. The IgCC initiative began in 2009 with cooperating sponsors American Institute of Architects (AIA) and ASTM International. The release of Public Version 1.0 was announced by the International Code Council on March 11, 2010. Public Version 2.0 was released on November 19, 2010. This law in its final format was officially published in March 2012. It applies to all new and renovated commercial buildings and residential buildings in excess of three stories. The latest updated version is the 2015 IgCC which was released in June 2015, and an upcoming version is the 2018 IgCC Development.

This historic code was long overdue and was bound to have a significant impact on future trends as it set mandatory baseline standards for all aspects of building design and construction, including site impacts, energy and water efficiency, building waste, and materials. Local governments and states have the choice of adopting the code, but once they do, it becomes enforceable. Furthermore, according to Wikipedia, the goal of the IgCC is to decrease energy usage and carbon footprints along with several other issues including:

- The code addresses site development and land use, including the preservation of natural and material resources as part of the process.
- Enforcement of the code will improve indoor air quality (IAQ) and support the use of energy-efficient appliances, renewable energy

systems, water resource conservation, rainwater collection and distribution systems, and the recovery of used water, also known as gray water.

- The IGCC emphasizes building performance, including features such as a requirement for building system performance verification along with building owner education, to ensure the best energy-efficient practices are being carried out.
- A key feature of the new code is a section devoted to “jurisdictional electives,” which will allow customization of the code beyond its base-line provisions to address local priorities and conditions.

Thus, with this new National Building Code, the concept of building “green” ceased to be in the realm of the theoretical and moved deep into the mainstream of current construction practice, and the general acceptance by the industry as well as familiarity with green elements and procedures will continue to drive down building costs. The method of building construction and materials that is employed also impacts the development of IAQ that can present an array of health challenges. Green buildings can address many of these environmental concerns, which is why it has become an essential component of our society. Building “green” therefore not only offers an opportunity to use existing resources more effectively but at the same time helps create healthier buildings, improve employee productivity, reduce the negative impact on the environment, in addition to achieving significant cost savings over the building’s lifecycle. Green buildings are also referred to sometimes as sustainable buildings, perhaps because they are structures that are designed, built, renovated, operated, or reused in an ecological and resource-efficient manner.

In today’s world of rapidly dwindling fossil fuel, the increasing impact of greenhouse gases on our climate has made sustainable architecture particularly relevant. For this and other reasons, the new national building codes go a long way to addressing these pressing needs to find suitable ways to reduce buildings’ energy loads, increase building efficiency, and employ renewable energy resources in our facilities. Green construction is environmentally friendly because it uses sustainable, location-appropriate building materials and employs building techniques that reduce energy consumption. Indeed, the primary objectives of sustainable design and construction are to avoid resource depletion of essential resources such as energy, water, and raw materials, and to prevent environmental degradation. Sustainability also places a high priority on health issues, which is partly why green buildings are generally more comfortable and safer to live and work in (Fig. 3.1) than conventional buildings.



Figure 3.1 The U.S. Green Building Council awarded The Kresge Foundation headquarters which is built on a three-acre site in Troy, Michigan, a Platinum-level rating, the highest attainable level in the Leadership in Energy and Environmental Design rating system. The state-of-the-art facility was completed in 2006 and serves as a model of sustainable design and an educational resource for the local community. The headquarters integrates a 19th century farmhouse and barn—part of the offices for many years—with a new contemporary two-level, 19,500-square-foot, glass and steel building. *Source: Kresge Foundation.*

Familiarity with the new IgCC as well as other “green” certification systems such as LEED and Green Globes is essential for government (federal and state) contractors and certainly is recommended for contractors in the private sector. Even before the introduction of the new green codes, various arms of the federal government required that their public projects meet certain “green” standards whether it be LEED certification standards, Green Globes, or ENERGY STAR, etc., in addition to various monetary and tax incentives. For example, the General Services Administration (GSA) required that all building projects meet the LEED certified level and target the LEED Silver level. The GSA however, while strongly encouraging projects to apply for certification, did not require it. The U.S. Navy also, while requiring appropriate projects to meet LEED certification requirements, does not require actual certification. On the other hand, the U.S. Environmental Protection Agency (EPA) requires all new facility construction and acquisition projects consisting of 20,000 sq. ft. or more to achieve a minimum LEED Gold certification. The U.S. Department of Agriculture also now requires all new or major renovation construction to achieve LEED Silver certification. We have yet to assess how the new National

Green Building Codes will impact organizations such as LEED, Green Globes, etc.

Some of the more important reasons why it is worthwhile for owners and developers to consider green building design and construction include:

1. Green buildings are generally energy efficient which means that they will save on operating costs over time; at a time of sharply rising energy costs, this can be particularly useful.
2. Many government agencies provide financial incentives for green building projects which provide a great inducement for building owners and developers to cash in on the “greenness” of their development projects through tax credits, financial incentives, carbon and renewable energy tradable credits, and net metering excess donations. Whether these incentives will be affected by the new codes or not has yet to be determined.
3. Not many people realize that in some cases it may actually be cheaper to build green. For example, a building that takes advantage of passive solar energy and includes effective insulation may require a smaller, less expensive HVAC system to serve the building. Also, purchasing recycled products can often be cheaper than purchasing comparable new products, and incorporating a construction plan that minimizes waste will ultimately save on hauling and landfill charges.
4. The market demand for green buildings continues to rise, particularly in high-end residential projects and prestige corporate office projects. A BOMA (Building Owners and Managers Association) Seattle survey, for example, recently found that 61% of real estate leaders believe that green buildings enhance their corporate image and 67% of these leaders also believe that over the next 5 years tenants will increasingly make green features of a property an important consideration when choosing space.
5. Green buildings are in a much better position to respond to existing and future governmental regulation. Building construction and operations are a major factor in nationwide greenhouse gas emissions and energy use, and we can expect future governmental regulations and the new green codes to present a major challenge directed at the building industry.
6. Green building helps contribute to conservation, and one of the cheapest ways of stretching a limited resource is to conserve it. If new buildings can be built and operated in a way that conserves energy and materials, these limited resources will go farther and minimize the need for capital-intensive projects to increase them.

7. Support green building practices is important because it helps reduce greenhouse gas emissions which in turn can help prevent climate change. Greenhouse gases are those gases in the atmosphere that are transparent to visible light but which absorb infrared light reflected from the earth, thus trapping heat in the atmosphere. Many naturally occurring gases have this property, including water vapor, carbon dioxide, methane, and nitrous oxide. A number of human-made gases such as some aerosol propellants also have this property.

On the other hand, with conventional methods of construction, owners and developers face a number of challenges such as:

- Higher final construction costs
- Prolonged project closeout
- Often over budget
- Frequently over schedule
- Excessive change orders
- Greater potential disputes, arbitration, and litigation
- Inability to solve problems satisfactorily



3.2 GREEN BUILDING PRINCIPLES AND COMPONENTS

The best approach to sustainable design that is both environmentally sensitive and reduces energy use over the life of the building is to adopt a program or programs that are designed to meet all sought objectives. And while the clear intent of green building is to be sited, designed, constructed, and operated to enhance the well-being of its occupants and to support a healthy community and natural environment with minimal adverse impact on the ecosystem (Fig. 3.2), this is not always easy to achieve.

3.2.1 Principles of Green Design

Cities and municipalities across the country are now adopting green building standards, which is why for many years ASHRAE and ICC have

in accordance with the project's erosion control plan. (b) Rooftop photovoltaic panels. (c) Auditorium interior. Bren Hall uses silt fencing, straw-bale catch basins, and scheduled grading activities in accordance with the project's erosion control plan. Building Bren Hall with sustainable materials and methods is estimated to have added only 2% to the building cost, which will easily be offset over time by energy savings. *Source: Donald Bren School of Environmental Science & Management at www.esm.ucsb.edu; photos Kevin Matthews, Artifice Images.*

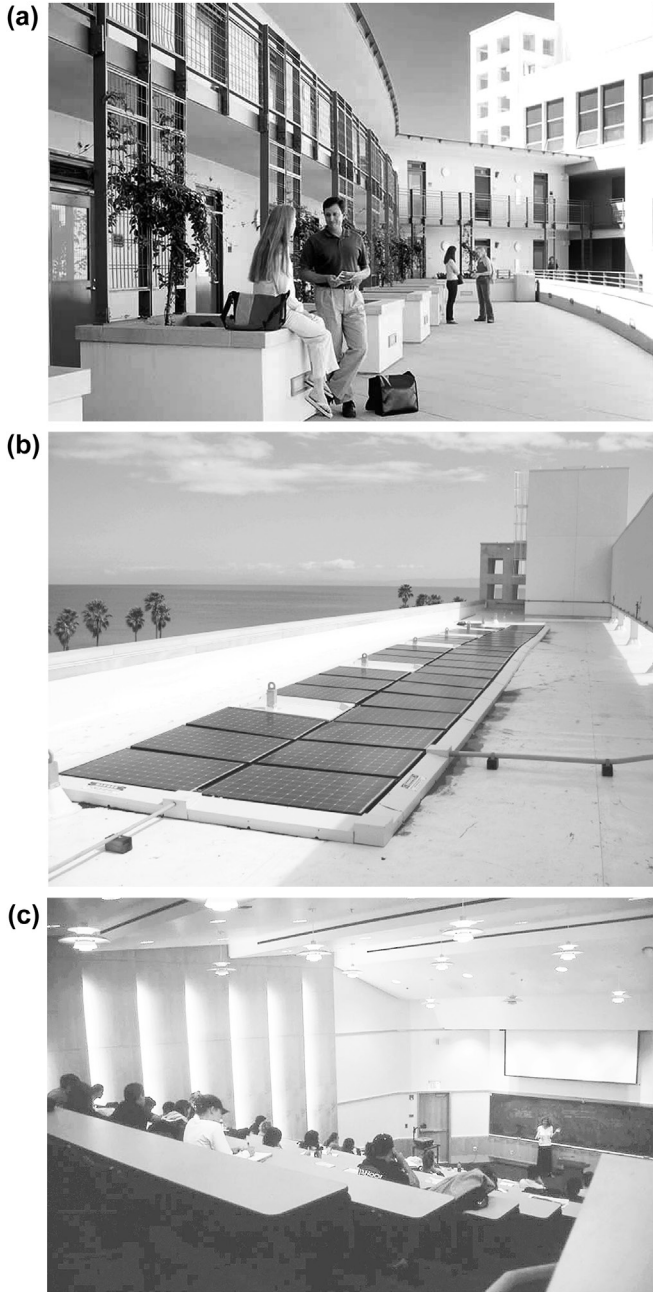

Figure 3.2 (a) Bren Hall—faculty and students on third-floor terrace of Donald Bren School of Environmental Science & Management at UCSB which is a LEED Gold Pilot project. It utilized silt fencing, straw-bale catch basins, and scheduled grading activities

worked on the development of specific codes and standards that can be transformed into the industry standard of care for the design, construction, operations, and maintenance of both commercial and residential buildings in the United States and globally. Prior to the recently launched IgCC, the USGBC has been leading a nationwide green building movement centered on the LEED Green Building Rating System. LEED which was launched in 2000 has been mandated by many jurisdictions as a de facto building code. The convergence of these efforts in the IgCC may be the most significant development in the buildings industry over the last decade. We are currently in the process of evaluating just how the new IgCC codes will impact organizations such as LEED and Green Globes in the years to come. But as ICC Chief Executive Officer Richard P. Weiland lately stated, “The emergence of green building codes and standards is an important next step for the green building movement, establishing a much-needed set of baseline regulations for green buildings that is adoptable, usable and enforceable by jurisdictions,” and “The IgCC provides a vehicle for jurisdictions to regulate green for the design and performance of new and renovated buildings in a manner that is integrated with existing codes as an overlay, allowing all new buildings to reap the rewards of improved design and construction practices.”

From state-of-the-art building technologies to inventive construction methods and better decision-making systems, projects are getting smarter. Given the fast development of emerging construction opportunities, owners should demand faster projects, lower costs, and improved buildings. In today’s competitive world, the practice of sustainable architecture and construction revolves mainly around innovation and creativity. One of the main attributes of green building is that materials and techniques are employed that do not have a negative impact on the environment. Likewise, the building’s inhabitants do not choose materials solely because they are more familiar with their use. For example, there are many recycled products that can be used in the construction of sustainable structures like ceramic floor tiles which can be made from recycled glass. Bamboo flooring is another suitable alternative to wood that is less expensive and is actually harder than hardwood floors and more durable. Also, flooring made from cork oak bark, for example, is friendly to the environment, since cork harvesting does not harm the trees it is taken from.

It is important to address the many traditional building design concerns of economy, utility, durability, and aesthetics. Green design strategies underline additional concerns regarding occupant health, the environment, and

resource depletion. To address all these concerns, there are numerous green design strategies and measures that can be employed such as:

- Encourage use of renewable energy and materials that are sustainably harvested
- Ensure maximum overall energy efficiency
- Ensure that water use is efficient
- Minimize waste water and run-off
- Conserve nonrenewable energy and scarce materials
- Optimize site selection to conserve green space and minimize transportation impacts
- Minimize human exposure to hazardous materials
- Minimize ecological impact of energy and materials used
- Encourage mass transit, occupant bicycle use, and other alternatives to fossil-fueled vehicles.
- Conserve and restore local air, water, soils, flora, and fauna
- Minimize adverse impacts of materials by employing green products
- Building orientation to take maximum advantage of sunlight and microclimate

By taking a holistic approach to implementing these strategies, puts us in a better position to preserve our environment for future generations by conserving natural resources and protecting air and water quality. It also provides critical benefits by increasing comfort and well-being and helping to maintain healthy air quality. Green building strategies are also good for the economy by reducing maintenance and replacement requirements, reducing utility bills and lowering the cost of home ownership, and increasing property and resale values. In practical terms, green building is a whole-systems-approach to building design and construction that employ features including:

1. Energy-efficient and water-saving appliances, fixtures, and technologies
2. Building quality, durable structures with good insulation and ventilation
3. Taking advantage of the sun and site to increase a building's ability for natural heating, cooling, and daylighting
4. Recycling and minimizing construction and demolition waste
5. Use of healthy products and building practices
6. Incorporation of durable, recycled, salvaged, and sustainably harvested materials
7. Landscape to use native, drought-resistant plants and water-efficient practices (Fig. 3.3)
8. Designing for livable neighborhoods

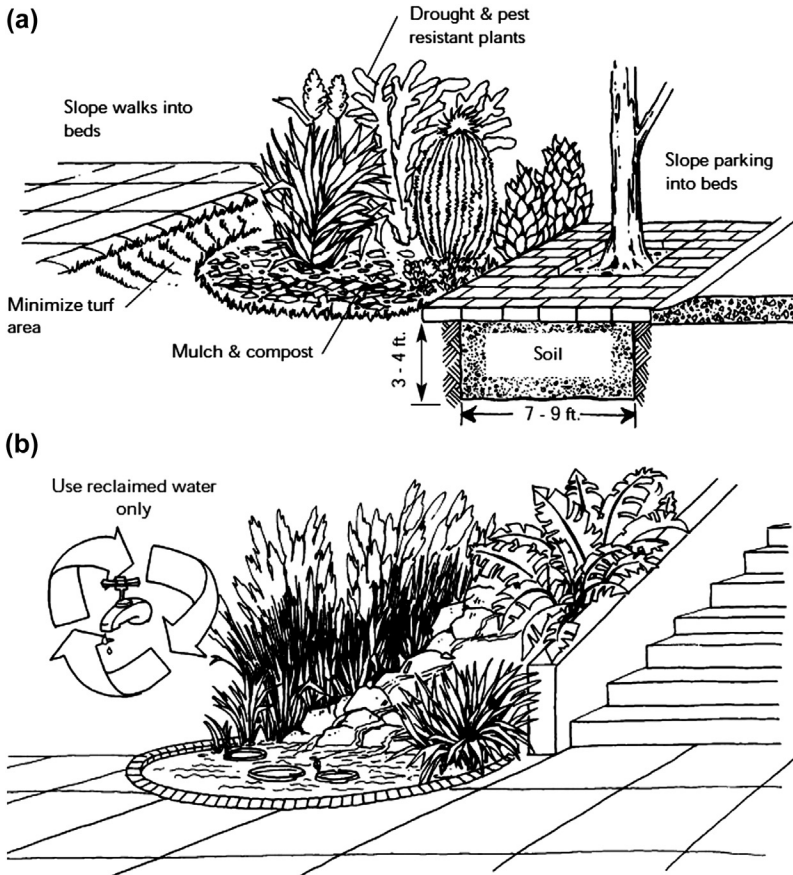

Figure 3.3 (a) Sketch showing the use of native and drought-resistant planting that can significantly enhance the environment in addition to providing opportunities for food and decorative gardens. Sketch (b) shows the use of reclaimed water. *Source: City of Santa Monica Green Building Guidelines for Design: Landscape, 2010.*

Integrated Design

It has become almost imperative to achieve success in green building to employ a holistic approach and have an integrated design team that includes the designers, BIM manager, structural, mechanical, electrical, civil, lighting, plumbing, and landscape engineers, and possibly others, in addition to the contractor, to work with the project owner or developer to find the most effective way to meet the owner's goals and objectives. This is aided by adapting the various systems to each other as an integrated whole and recognizing the interconnectivity of the systems and components that cumulatively make up a building and the disciplines involved in its design. Unlike the traditional approach, integrated

design correctly assumes that each system affects the functioning of the other systems, which is why these systems must be harmonized if they are to perform together at maximum efficiency. Optimizing the building's performance and thus reducing the adverse impact on the environment and minimizing its total cost must be the ultimate objective of sustainability.

It should be apparent from the above that the first and most important steps toward sustainability in the area of real estate development is to focus on areas relating to energy efficiency, water efficiency, waste efficiency, and design efficiency, on a per building and a whole development basis. The following factors are the main components for achieving green building and are rewarded by the majority of green rating systems including LEED, BREEM, and Green Globes.

Site Selection

This is one of the cardinal features of successful green building; it basically emphasizes the reuse and restoration of existing buildings and sites. The intent of the sustainable site selection is to encourage good stewardship of the land in addition to ensuring that any negative project impacts on surrounding areas during and after project construction are minimized. Site selection is also concerned with rehabilitating contaminated or brownfield sites (determined by a local, state, or federal agency), as well as preserving natural and agricultural resources. Other features of site selection include the promotion of biodiversity and maximizing open space by reducing development footprint as well as reducing light trespass to minimize light pollution associated with interior light building and exterior light luminance not to exceed site boundaries. Additionally, it includes stormwater management through supporting natural hydrology and reducing water pollution by increasing pervious area and on-site infiltration, reduction of construction waste, reducing the heat island effect, and encouraging use of public or low-environmental-impact transportation options.

The IgCC, however, significantly eliminates development on greenfields (undeveloped land), although there are exceptions based primarily on existing infrastructure. It includes clear guidelines for site disturbance, irrigation, erosion control, transportation, heat island mitigation, gray water systems, habitat protection, and site restoration.

Energy Efficiency

In many ways this is the most important issue surrounding green building and is also the element of a project that can most significantly impact

reductions in the operating costs. Energy efficiency measures may be eligible for federal and state tax credits and other financial incentives as required by the current ASHRAE/IESNA 90.1 standard. The comprising components of this standard are (1) the building envelope, (2) heating, ventilation, and air conditioning, (3) water heating, including swimming pools, (4) power, including building power-distributed generation systems, (5) lighting, and (6) other electrical equipment. As for the IgCC requirements, it stipulates that total efficiency must be “51% of the energy allowable in the 2000 International Energy Conservation Code” (IECC), and building envelope performance must exceed that by 10%. It also sets minimum standards for lighting and mechanical systems and mandates certain levels of submetering and demand-response automation. California also approved new green codes (“CalGreen”) which took effect in January 2011. David Walls, executive director of the state building commission says that “The new code’s mandatory measures will help reduce greenhouse-gas emissions by 3 million metric tons by 2020.” As far as California Title 24 standards are concerned, the majority of buildings generally strive to meet this standard. The following strategies contribute to achieving both the IgCC and CalGreen goals:

- Energy-efficient heat/cooling system should be used in conjunction with a thermally efficient building shell. Other prudent energy saving opportunities may exist with heat recovery options and thermal energy storage. High R-value wall and ceiling insulation to be installed; minimal glass to be employed on east and west exposures and light colors for roofing and wall finishes.
- Encourage the incorporation of renewable energy sources such as solar, wind, or other alternative energy into the HVAC system to reduce operational costs and minimize the use of fossil fuels.
- Minimize as much as possible electric loads created by lighting, appliances, and other systems.
- Passive design strategies, including building shape and orientation, passive solar design, and the use of natural lighting, can dramatically impact building energy performance.
- Employ modern energy management controls as improperly programmed controls and outdated technology can mislead a building owner to believing that a building is performing more efficiently than it actually is. Replacing, upgrading, or reprogramming the temperature controls and the energy management system will ensure equipment operates at optimum efficiency.
- Strategies should be developed to provide natural lighting and views where this will improve well-being and productivity. A green building is typically designed to take advantage of the sun’s seasonal position to

heat a building's interior in winter and frequently incorporates design features such as light shelves, overhanging eaves, or landscaping to mitigate the sun's heat in summer. Room orientation should generally be designed to improve natural ventilation.

- Install high-efficiency lighting systems with advanced lighting control systems and incorporating motion sensors linked to dimmable lighting controls. Inclusion of task lighting can reduce general overhead light levels.
- Use BIM computer modeling when possible to optimizing design of electrical and mechanical systems and the building shell.
- Most existing buildings have never been commissioned during construction, and as they age they require regular maintenance. In this respect, retro-commissioning can be extremely useful by resolving problems that occurred during the design or construction phases, or address problems that have developed throughout the building's life, and thus make a substantial difference in energy usage and savings.

It should be noted that the ASHRAE Standard 90.1, 2013 edition (ANSI/ASHRAE/IES Standard 90.1-2013—Energy Standard for buildings except low-rise residential buildings) has now been updated to include new features and more detailed requirements, as well as including changes from more than 100 addenda. ASHRAE Standard 90.1 is on continuous maintenance and is designed to be republished on a 3-year cycle. The next updated version is 90.1-2016. As for the 2013 modifications, they include:

- “Revised, stricter opaque element and fenestration requirements at a reasonable level of cost-effectiveness
- Improvements to daylighting controls, space-by-space lighting power density limits, and thresholds for toplighting
- Revised equipment efficiencies for heat pumps, packaged terminal air conditioners (PTACs), single package vertical heat pumps and air conditioners (SPVHP and SPVAC), and evaporative condensers
- New provisions for commercial refrigeration equipment and improved controls for heat rejection and boiler equipment
- Improved requirements for expanded use of energy recovery, small-motor efficiencies, and fan power control and credits
- Improved equipment efficiencies for chillers
- Clarifications for the use of prescriptive provisions when performing building energy use modeling, and revisions to enhance capturing daylighting when performing modeling calculations
- A new alternate compliance path to Section 6, “Heating, Ventilating, and Air-Conditioning,” for computer room systems, developed with ASHRAE Technical Committee (TC) 9.9.”

Water Efficiency and Conservation

Conservation is a particularly cost-effective strategy that should be pursued aggressively, regardless of other parallel efforts to ensure a sustainable water supply. This establishes maximum consumption of fixtures and appliances and sets specifications for rainwater storage and gray water systems. Of note, the United States annually draws out an estimated 3700 billion gallons more water from its natural water resources than it returns. Many municipalities have legislation in place requiring storm water and wastewater efficiency measures while the Energy Policy Act of 1992 which was enacted to provide for improved energy efficiency, already requires water conservation for plumbing fixtures. The need to implement water efficiency measures is to conserve our depleting water resources and preserve water for agricultural uses, in addition to reducing the pressure on water related ecosystems. There are numerous efficiency measures that can be implemented to advance water efficiency and conservation including:

1. Employing ultra low-flush toilets, low-flow shower heads, and other water conserving fixtures will help minimizing wastewater.
2. Incorporate dual plumbing systems that use recycled water for toilet flushing or a gray water system that recovers rainwater or other non-potable water for site irrigation.
3. Recirculating systems to be used for centralized hot water distribution, and point-of-use hot water heating systems for more distant locations.
4. Use a water budget approach that schedules irrigation systems.
5. Incorporate self-closing nozzles on hoses and state-of-the-art irrigation controllers.
6. Employ micro-irrigation techniques to supply water in nonturf areas; buildings to be metered separately from landscape.

Materials and Resources

Choosing the most appropriate building material is very important because it can have an enormous impact on the natural environment partly caused by the many processes involved such as extraction, production, and transportation, all of which can negatively impact our ecosystem. But it is also important because some materials may release toxic chemicals that are harmful to building occupants. Green building generally avoids using potentially toxic materials such as treated woods, plastics, and petroleum-based adhesives which can degrade air and water quality and cause health problems. Additionally, building demolition may cause materials to release hazardous or non-biodegradable material pollutants into the natural environment or into drinking water reserves. Sustainable

building materials also reduce landfill waste of which the IgCC codes mandate a minimum of 50% of construction waste must be diverted from landfills, and at least 55% of building materials must be salvaged, recycled-content, recyclable, biobased, or indigenous. The IgCC also mandates that buildings must be designed to span for a minimum of 60 years of life, and must show a service plan that justifies that. The following aspects should be considered when choosing building materials for a project:

- Choose sustainable construction materials and products whenever possible. Their sustainability can be measured by several characteristics such as recycled content, reusability, minimum off gassing of harmful chemicals, zero or low toxicity, durability, sustainably harvested materials, high recyclability, and local production. Use of such products promotes resource conservation and efficiency, minimizes the adverse impact on the environment and helps to harmonize with its surroundings.
- Employing dimensional planning and other material efficiency strategies reduce the amount of building materials needed and cut construction costs. For example, the design of rooms to 4-foot multiples minimizes waste by conforming to standard-sized wallboard and plywood sheets.
- If possible, reuse and recycle construction and demolition materials. Using recycled-content products also cuts costs and assists in the development of markets for recycled materials that are being diverted from landfills, an example of which is the use of inert demolition materials as a base course for a parking lot.
- Allocate adequate space to facilitate recycling collection and to incorporate a solid waste management program that reduces waste generation.
- Require waste management plans for managing materials through deconstruction, demolition, and construction.

Employing recycled/reused materials helps to ensure the sustainability of resources. If building projects use only virgin raw materials these materials will gradually be exhausted. As the availability of raw materials become scarce, prices will rise and before long the materials will no longer be obtainable. This trend has already started to impact the availability of certain raw materials which are either no longer available or have become very scarce, and can only be obtained recycled from existing projects. Recycling and reusing materials helps ensure that these materials will be readily available for years to come.

Indoor Environmental Quality and Safety

The adoption of green construction principals can contribute substantially to a superior interior environment, which in turn can significantly reduce

the rate of respiratory disease, allergy, asthma, sick building symptoms (SBS), and enhance tenant comfort and worker performance. Materials such as carpet, cabinetry adhesives, paint and other wall coverings with zero or low levels of Volatile Organic Compounds (VOCs) will release less gas and improve a building's IAQ. On the other hand, building materials and cleaning and maintenance products that emit toxic gases, such as volatile organic compounds (VOC) and formaldehyde should be avoided as these gases can have a very negative impact on occupants' health and productivity. Daylighting can also improve the interior quality by boosting the occupant's mood with natural light. Adequate ventilation and a high-efficiency, in-duct filtration system should be provided. Heating and cooling systems that ensure proper ventilation and filtration can have a dramatic and positive impact on IAQ. The potential financial benefits of improving indoor environments can be very significant.

To prevent indoor microbial contamination materials should be chosen that are resistant to microbial growth. Provide effective roof drainage and drainage for the surrounding landscape, and proper drainage of air-conditioning coils. Other building systems should be designed to control humidity.

Waste Management Issues

These issues are connected to several areas of green building, from waste reduction measures during construction to waste recycling measures. Separating trash to be recycled has become a way of life in America. In fact it is estimated that 31.5 million tons of construction waste is produced annually in the United States. The EPA, says that more than 34% of garbage is recycled, a gain of over 400% since 1960. Furthermore, nearly 40% of solid waste in the United States is produced by construction and demolition.

Commissioning Operation and Maintenance

Green building measures cannot achieve their objectives unless they function as intended according to the specifications and contract documents. The incorporation of operating and maintenance factors into the design process of a building project can contribute to the creation of healthy working environments, higher productivity, and reduced energy and resource costs. Whenever possible therefore, designers should specify materials and systems that simplify and reduce maintenance and life-cycle costs, use less water, energy, and are cost-effective. Other benefits of commissioning besides reduced energy costs include lower operating costs, reduced contractor

callbacks, better building documentation, and verification that the systems are performing in accordance with the owner's project requirements.

Building commissioning and enhanced commissioning are also necessary imperatives that include testing and adjusting the mechanical, electrical, and plumbing systems to ensure that all equipment meets design intent. It also includes instructing and educating building owners and the upkeep staff on the operation and maintenance of equipment. As buildings age their performance will generally decline and can only be assured through regular maintenance or through retro-commissioning.

Livable Communities and Neighborhoods

We need to help define those structures and strategies that will advance the design of more livable ecofriendly communities and neighborhoods. There are several issues that pertain to community and neighborhood development and which should be addressed such as the application of ecologically appropriate site development practices, the incorporation of high-performance buildings, and the incorporation of renewable energy. In addition, the development of new communities and neighborhoods, and the housing incorporated into such developments, may also involve looking into issues not normally considered in single-structure projects. Such issues may include evaluating the community's location, the proposed structure and density of the community, and the ramifications of the community on transportation requirements. Other issues that should be considered include setting the standards for the community's infrastructure and the standards to be applied to specific development projects within the community, as all these factors influence the environmental impacts of the development, and the ongoing livability of the community as an integrated whole.

The introduction of the new IgCC has clearly impacted the construction industry which has for some years been part of the mainstream in the United States. Likewise, the escalating costs of energy and building materials, coupled with warnings from the EPA about the toxicity of today's treated and synthetic materials, have prompted architects and engineers to revise their approach to building techniques that employ native resources as construction materials and increasingly use nature (daylight, solar, and ventilation) for the heating and cooling process. Green developments are generally more efficient, last longer and cost less to operate and maintain than conventional buildings. Moreover, green developments generally provide greater occupant comfort and higher productivity than conventional

developments, which is why most sophisticated buyers and lessors prefer them, and are usually willing to pay a premium for green developments.

The U.S. Department of Energy (DOE) estimates that buildings in the US consume annually more than one-third of the nation's energy and contribute approximately 36% of the carbon dioxide (CO₂) emissions released into the atmosphere. This is partly due to the fact that the vast majority of buildings today continue to use mechanical equipment powered by electricity or fossil fuels for heating, cooling, lighting, and maintaining IAQ. This means that the fossil fuels used to condition buildings and generate electricity are having an enormous negative impact on the environment; they emit a plethora of hazardous pollutants such as volatile organic compounds (VOCs) that cost building occupants and insurance companies millions of dollars annually in health care costs. In addition, we have the problem of fossil fuel mining and extraction which adds to the adverse environmental impacts, while fomenting price instability which is causing concern among both investors and building owners. The latest IgCC will foster and mandate the creation of buildings that use less energy and both reduces and stabilizes costs, as well as having a positive impact on the environment.

The U.S. Department of Energy (DOE) early on had the foresight to appreciate the urgent need for buildings that were more energy efficient and in 1998 it took the initiative and decided to collaborate with the commercial buildings industry to develop a 20-year plan for research and development on energy-efficient commercial buildings. DOE's High-Performance Buildings Program's primary mission is to help create more efficient buildings that save energy and provide a quality, comfortable environment for workers and tenants. The program is targeted mainly towards the building community, particularly building owners/developers, architects and engineers. Today we have in place the knowledge and technologies required to reduce energy use in our homes and workplaces without having to compromise comfort or aesthetics. The building industry has until recently remained aloof or uninformed and has resisted taking full advantage of these important advances. It is expected that with the new green codes coming into play future building projects will be designed and operated taking into account the many environmental impacts to produce healthier and more efficient buildings.

3.2.2 High Performance and Smart/Intelligent Buildings

Green buildings are increasingly being transformed into high-performance "smart/intelligent buildings" that are equipped with the latest technologies,

integrated systems, custom user applications and large amounts of data. The concept of intelligent buildings takes green to a whole new level. Not surprisingly, high performance buildings and building automation have become recognizable landmarks in today's contemporary society; they typically consist of programmed, computerized, "intelligent" network of electronic devices that monitor and control the mechanical and lighting systems in a building. The United States Energy Independence and Security Act 2007, defines a high performance building as, "A building that integrates and optimizes on a lifecycle basis all major high performance attributes, including energy [and water] conservation, environment, safety, security, durability, accessibility, cost-benefit, productivity, sustainability, functionality, and operational considerations" (Energy Independence and Security Act, 2007, 401 PL 110-140).

On March 16, the 2016 Building Energy Summit was held in Washington, DC, and according to Natalie Grasso, senior editor for *Work Design Magazine*, the five things learned at the 2016 Building Energy Summit which brought together building owners, energy experts, and technology forerunners to discuss the business and social case for more energy efficient buildings are:

1. By 2030, over 500 billion devices will be connected to the Internet
2. The economic ROI on smart buildings is a big one — but it's the smallest component of the value proposition as a whole
3. Real estate is about to become a totally digital business, and it's going to make the workplace better
4. 23% of global energy use is from commercial buildings
5. Even old buildings can be energy pioneers

Due partly to rising energy costs an increasing number of new buildings are incorporating central communications systems to the extent that the "intelligent" or "smart" building has become an integral part of mainstream America. Indeed, many of today's federal facilities have succeeded in achieving high performance buildings that save energy and reduce the environmental impact on our lives. Increasing consumer demand for clean renewable energy and the deregulation of the utilities industry have encouraged and energized growth in green power such as solar, wind, geothermal steam, biomass, and small-scale hydroelectric sources of power. In addition, President Barak Obama's administration has encouraged small commercial solar power plants to emerge around the country and serve some energy markets within the United States.

The decision to operate a high performance building requires various proactive management processes for energy and maintenance. It may be

prudent and more effective therefore when deciding to implement high performance building projects to initially instigating a green design “charrette” or multi-disciplinary kick-off meeting to articulate a clear road map for the project team to follow. A crucial advantage of holding a green design charrette during the early stage of the design process, is that it offers team professionals (with possible assistance of green design experts and facilitators), to brainstorm on achieving design objectives as well as alternative solutions. This goal-setting approach helps identify green strategies for members of the design team and helps facilitate the group’s ability to reach a consensus on performance targets for the project and to ensure that these performance targets are achieved.

Designers of sustainable buildings need to pay careful attention to measured performance expectations. Once performance measures are determined a follow up is required to establish performance goals and the metrics to be employed for each measure. Minimum requirements, or baselines, are typically defined by codes (e.g., the IgCC) and standards which may differ from one jurisdiction to another. Alternatively, performance baselines can be designed to exceed the average performance of a specific building type, measured against similar buildings that have recently been built or against the performance of a very well documented building of a particular type.

Over recent years, several green building rating systems have been established to set standards for the evaluation of high performance. To date, the most widely recognized system for rating building performance in the United States is LEED (Leadership in Energy and Environmental Design) and Green Globes which provide various consensus-based criteria to measure performance, along with useful reference to baseline standards and performance criteria. However, a LEED or Green Globes certification, by itself, does not ensure high performance in terms of energy efficiency as certification may have been achieved by acquiring other non-energy related categories such as Materials and Resources or Sustainable Sites. For this reason specific energy related goals must still be set. To some degree this is being addressed in the United States by the recently adopted national green codes (IgCC) and California’s “CalGreen” that mandate green specifications.

In today’s highly competitive field, many professionals consider integrated design to be the cornerstone of the green building process. It is enhanced by the use of the latest computer energy modeling tools such as the Department of Energy’s DOE 2.1E, Building Information Modeling (BIM) and other computer programs. These programs can inform the building team of the impacts of energy-use implications very early in the

design process by factoring in relevant information such as climate data, seasonal changes, building massing and orientation, and daylighting. It can also readily prompt investigation and survey of cost-effective design alternatives for the building envelope and mechanical systems by forecasting energy use of various combined alternatives. But before dwelling too deeply into green design and the integrated design process and to fully comprehend and understand its meaning, it may be advisable, if not necessary, to first describe the more conventional design process. The traditional process is a linear and segmented process whereas integrated design is a more interactive, more egalitarian and more consultative process. Thus the traditional design approach typically starts with the architect and the client agreeing on a budget and design concept, followed by a general massing scheme, typical floor plans, schematic elevations and, usually the general exterior appearance as determined by these design criteria and design intent. The mechanical and electrical engineers are then asked to implement the design and to suggest appropriate systems. Building information modeling (BIM) programs are increasingly being introduced and incorporated into the design process.

Although this is gradually changing, the conventional design approach remains at this point the main method employed by the majority of general-purpose design consultant firms, which unfortunately tends to suppress the achievable performance to conventional levels. However, the introduction of the updated green codes will likely encourage a more holistic approach to design and construction, especially since the sequential contributions of the members of the design team in the traditional design process consists mainly of a linear structure. The opportunity for optimization is limited during the traditional design process, and optimization in the later stages of the process is usually difficult if at all viable. Research has shown that this process has often proven to be inferior and inappropriate producing high operating costs and often coupled with a sub-standard interior environment. These factors can have a negative impact on a property's ability to attract quality tenants or achieve desirable long-term rentals in addition to a reduced asset value for the property.

3.2.3 Building Information Modeling (BIM)

Over the years, we have seen building construction continue to grow in complexity and change under the influence of emerging technologies. To meet these challenges a number of new software programs have emerged that are having a positive impact on the entire design, planning and construction community. Among them is introduction of BIM software which is the latest

development in computer-aided design and which is being touted by many industry professionals as a lifesaver for complicated projects because of its ability to correct errors at the design stage and accurately schedule construction amongst other attributes. BIM embraces 3D modeling concepts, information database technology, and interoperable software in a computer application environment that design professionals and contractors can use to design a facility, simulate construction, and accurately estimate the project's cost.

In this regard, Autodesk says, “building information modeling (BIM) software facilitates a new way of working collaboratively using a model created from consistent, reliable design information – enabling faster decision-making, better documentation, and the ability to evaluate sustainable building and infrastructure design alternatives using analysis to predict performance before breaking ground.” In fact some industry professionals forecast that buildings in the not too distant future will be built directly from the electronic models that BIM and similar programs create, and that the design role of architects and engineers will dramatically change (Fig. 3.4).



Figure 3.4 Highlands Lodge Resort and Spa project, a joint venture of Q&D Construction and Swinerton Builders, Inc. where Vico, a BIM software package was used. The five-star hotel and high-end luxury condominiums has a total gross floor area of 406,500 sq. ft./37,720 sq. meter and is built on a roughly 20 acre site at the Northstar-at-Tahoe Ski Resort in Northern California. *Source: Vico Software Inc.*

In this respect, BIM is gradually changing the role of drawings for the construction process, improving architectural productivity, and making it easier to consider and evaluate design alternatives. Combined with clash detection programs, designers can ensure no systems interfere with each other, preventing field coordination problems before they arise on the jobsite. This modern modeling technology is particularly valuable in sustainable design because it enables project team members to create a virtual model of the structure and all of its systems in 3D in a format that can be shared with the entire project team thereby facilitating the process of integrating the various design teams' work. This allows team members to identify design issues and construction conflicts and resolve them in a virtual environment before the actual commencement of construction, thus directly promoting the utilization of an integrated team process. This is discussed in much greater detail in [Chapter 5](#) (Building Information Modeling).

Already BIM technology is being employed by a vast array of architectural and engineering consultants, and as BIM's popularity continues to surge it is rapidly becoming pivotal to building design, visualization studies, cost analysis, contract documents, 3D simulation and facilities management. As Autodesk Revit is aggressively making headway in its market penetration of architectural and engineering firms it is projected that within the next few years, Revit will have achieved a significant market share of major projects designed in the United States and possibly other countries.



3.3 HIGH PERFORMANCE DESIGN STRATEGIES

Although it is difficult to find a definition of a high-performance building that everyone agrees upon, perhaps the one characteristic that most will agree upon is that high performance buildings reflect design excellence. This may be partly because they are typically designed in a holistic, integrative fashion that allows them to offer benefits such as minimize environmental impact (significantly reducing greenhouse gas emissions), save energy and natural resources, provide optimized healthy interiors, and produce cost savings over their life cycle. Yet the real value of high performance buildings can be easily underestimated when using traditional accounting methods that fail to recognize “external” municipal and regional costs and benefits. A much greater accuracy can be achieved when high performance building cost evaluations effectively address the economic, social, and environmental benefits that typically accompany green buildings.

3.3.1 Green Design Strategies

Improved technology is making it much easier and more cost-effective for designers and engineering professionals to incorporate sustainability into their high performance design strategies. Likewise, there are many recommended practices that can reduce the environmental and resource impacts of buildings, and enhance the health and satisfaction of their occupants. The most prominent strategies that come to mind include:

- 1. Using less to achieve more:** The most effective green design solutions are able to address a number of needs with only a few elements. For example, a concrete floor may be simply finished with a colored sealant that reflects daylight for better illumination, and eliminates air pollutant emissions from floor coverings. The floor can also be used to store daytime heat and nighttime cold to provide occupant comfort. Thus a carefully designed element serves as structure, and finished surface, distributes daylight, and stores heat and cold, thus saving materials, energy resources, capital and operating costs.
- 2. Incorporate design flexibility and durability:** Buildings that are designed with the flexibility to adapt to changing functions over long useful lives reduce life-cycle resource consumption. Durable sustainable structural elements that contain generous service space and are able to accommodate movable partitions can last for many decades, instead of being demolished because they are incapable of adapting to changing building functions. Durable envelope assemblies reduce life-cycle maintenance and energy costs and improve comfort.
- 3. To achieve maximum effectiveness combinations of design strategies must be carefully considered:** Green buildings are incorporating increasingly complex systems of interacting and interrelated elements. Intelligent green design must consider the impact of these elements and systems on each other, and on the building as a whole. As an example, the need for mechanical and electrical systems is greatly affected by building form and envelope design. Combining strategies like daylighting, solar load control, and natural cooling and ventilation can all work together to reduce lighting, heating and cooling loads. Carefully combining these strategies can save resources and money, both in construction, operation and maintenance.
- 4. Take advantage of site conditions:** Buildings are usually considered more sustainable when they respond to local microclimate, topography, vegetation and water resources; they are also usually more comfortable and efficient than conventional designs that rely on technological fixes and ignore their

surroundings. As an example, Santa Monica in California has exemplary solar and wind resources for passive solar heating, natural cooling, ventilation and daylighting, but has meager local water supplies (some of which have recently been polluted). Taking advantage of such free natural resources, and conserving scarce high-priced commodities are appropriate approaches to reduce costs and connect occupants to their surroundings.

5. Adopt preventive maintenance, not repairing after the fact:

Addressing potential problems from the beginning by applying preventive maintenance is both practical and economically prudent. For example, using low-toxicity building materials and installation practices is more effective than diluting indoor air pollution from toxic sources by employing large quantities of ventilation air.

Another attribute of green design is “Smart Growth” which concerns many communities around the country. It relates mainly to the ability to control sprawl, reusing existing infrastructure, and creating walkable neighborhoods. Locating suitable places to live and work within walking distance or near public transport is an obvious advantage towards reducing energy. It is also more logical and resource-efficient to maintain or reuse existing roads and utilities than having to build new ones. The preservation of open spaces, farm lands and undeveloped land, strengthens and reinforces the evolution of existing communities and helps maintain their quality of life. It also helps reduce the pollution of the environment.

3.3.2 The Integrated Design Process (IDP)

There are several fundamental differences between the IDP approach to design and the conventional design approach. The IDP approach is basically a collaborative one for designing buildings that emphasizes the development of a holistic or whole building design process in which the owner takes on a more direct and active role in the process and the architect assumes the role of team leader rather than sole decision maker. Additional key consultants including the BIM, structural, electrical, mechanical, lighting, and other players become an integral part of the team from the outset and participate in the project’s decision making process – not after completion of the initial design (Fig. 3.5). Therefore, from a design perspective, the key process difference between green-building design and conventional design is the concept of integration. Therefore, practitioners of an integrated process need to develop new skills that might not have been previously required in their professional work. Some of these new required skills to succeed in applying the integrated process include:

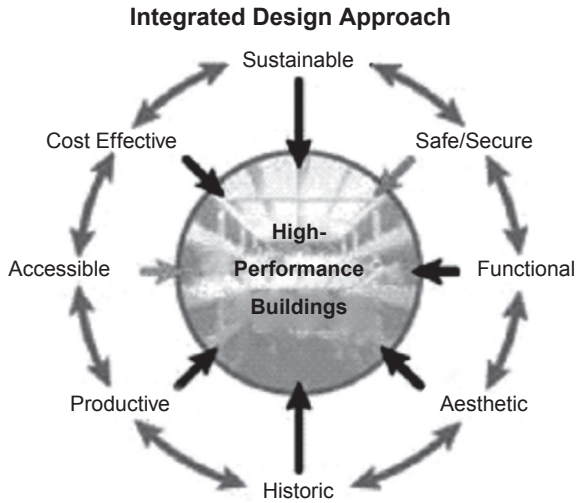

Figure 3.5 Diagram showing the various elements that impact the design of high-performance buildings using the Integrated Design Approach. With the integrated design approach multidisciplinary collaboration is required, including key stakeholders and design professionals, from conception to completion of the project.

critical thinking, analysis and questioning, teamwork, ability to collaborate with others on the team, good communication skills, and a deep understanding of natural processes. An integrated process differs in its way of thinking and working; it creates a team from professionals who have traditionally been used to working as distinct entities. Thus in the IDP approach the building is viewed as an interdependent system, as opposed to an accumulation of its separate components. The objective of looking at all the component systems together is to ensure that they work in harmony rather than conflict with each other.

Furthermore, now more than at any time in history, the successful design of buildings today requires the integration of various kinds of information from different consultants into a synthetic whole. And to achieve an effective and well-designed sustainable building project today indeed requires the employment of an integrated design process with clear and precise design objectives, which should be identified as early as possible and held in proper balance during the design process. This integrated design approach to design and construction has become necessary to achieve a successful high-performance building. For example, by working collaboratively as a team the main players (architect, engineers, BIM manager, landscape architect, etc.), can maneuver and direct the ground plane, building shape, section, and

planting scheme to provide increased thermal protection, and reduce heat loss and heat gain. By reducing heating and cooling loads the mechanical engineer, is able to reduce the size of mechanical equipment necessary to achieve comfort. Moreover, the architect, lighting and mechanical engineers can work in unison to design for example, a more effective interior/exterior element such as a light-shelf which can serve not only as an architectural feature, but can also provide needed sun-screening, and thus reduce summer cooling loads while at the same time allowing daylight to penetrate deep into the interior. This results in a more efficient environmental performance in addition to on-going operational savings.

Early in the IDP process, the project owner/client will typically appoint a person to undertake the role of leader for the project that is proficient and capable of leading a team to design and build the project on the basis of specific requirements in the form of a project brief for space and budgetary capacity. The project brief accompanying this planning activity should describe existing space use; include realistic estimates of both spatial and technical requirements, and contain a space program around which design activity can develop. Depending on a project's size, type and complexity, there may be a need to employ a construction manager (CM) or a general contractor and who may come on board at this point. It has been shown that the best buildings almost always result from active, consistent, organized collaboration among all the players.

Upon completing the Pre-design activities, the architect, designer of record (DOR), and other key consultants, in collaboration with the other team members or sub-consultants, may produce preliminary graphic proposals for the project or portions of it via a 3D modeling program (e.g., BIM) or manually. The intention of the preliminary proposals are meant more to stimulate thought and discussion than to describe any final outcome, although normally the fewer changes initiated before bidding the project the more cost-effective the project will be. It is crucial to involve all relevant consultants and sub-consultants early in the process in order to benefit from their individual insights and to prevent costly changes further along in the process. Also early in the process decision-making protocols and complementary design principles must be established in order to satisfy the goals of the project team's multiple stakeholders while achieving the overall project objectives. The final design that emerges will incorporate the interests and requirements of all project team participants including the owner, while also meeting the overall area requirements and project budget that was established during the Pre-Design phase of the project.

By this time a schematic design proposal will be in place which should include a site location and organization, a 3D model of the project, space allocation, and an outline specification including an initial list of systems and components that form part of the final design. A preliminary cost estimate can also now be made and depending on the size and complexity of the project, it may be performed by a professional cost estimator or computer program at this point. For smaller projects this service may be performed as part of a preliminary bidding arrangement by one or more of the possible builders. On larger projects, the cost estimate can be linked to the selection process for a builder, assuming other prerequisites are met such as experience, and satisfactory references. If a BIM manager is employed, he/she can perform this task.

The schematic design is followed by the design development phase. This phase entails going into greater detail for all aspects of the building, including systems and materials, etc. The collaborative process continues with the architect working hand in hand with the owner and the various contributors and stakeholders. The resulting outcome of this phase is a detailed design on which a consensus of all players exists and who may be asked to sign off. When the project design is developed using an integrated team approach, the end product is usually a design that is highly efficient with minimal, if not zero, incremental capital costs, and reduced maintenance and long-term operating costs and which avoid having to make costly changes late in the game.

At this point the development and production of *contract documents* follows which involves converting the design development information into formats that can be used for pricing, bidding, permitting, and constructing the project. An efficient set of contract documents can be achieved by careful scrutiny, and accountability to the initial program requirements as outlined by the design team and the client, in addition to careful coordination and collaboration with the technical consultants on the design team. Design, budgetary and other decisions continue to be made with the appropriate contributions of the various players. Changes in scope during this phase should be avoided as they can significantly impact the project and once pricing has commenced can invite confusion, errors, and added costs. Cost estimates may be made at this point, prior to or simultaneous with bidding, in order to assure compliance with the budget and to check the bids.

Even after the general contractor is selected during the *construction phase*, other members of the project team must remain fully involved, as there will remain many outstanding issues that will need to be addressed such

as previous decisions that may require clarification, or supplier samples and information that must be reviewed for compliance with the contract documents, and proposed substitutions that need evaluation. Whenever proposed changes affect the operation of the building, the owner/client must be informed and approval sought. Any changes in user requirements may require modifications to the building's design which will necessitate consultation with the other consultants and sub-consultants to assess the implications and ramifications that such changes may incur. Any proposed changes must be priced and incorporated into the contract documents as early as possible.

In the final analysis the ultimate responsibility for ensuring that the building upon completion meets the requirements of the contract documents lies with the design team. The level of a building's success of meeting program performance requirements can be evaluated through the commissioning and enhanced commissioning processes (preferably employing an independent third party). Here the full range of systems and functions in the building are evaluated and the design and construction team may be called upon to make some required modifications and adjustments to the systems. Colin Moar, commissioning operations manager for Heery International says, "To get the best value, hire the commissioning agent to get involved during the concept and schematic design phases". Upon the building becoming fully operational, a post-occupancy evaluation may be conducted to confirm that the building meets the original and emergent requirements for its use and that meet the owner's expectations. This is discussed in greater detail in [Chapter 15](#) (Green Business Development).

3.3.3 Green Building Design and Delivery

The full impact of the new National Green Building Code has yet to be determined although one thing seems certain, and that is that the process of green building design and construction differs fundamentally from traditional standard practice. Successful green buildings result from a number of things, including a design process that displays a strong commitment to the environment and to health issues. Measurable targets challenge the design and construction team, and allow progress to be tracked and managed throughout development and beyond. Employing computer energy simulations offers the ability to assess energy conservation measures early and throughout the design process. By collaborating early in the conceptual design process the expanded design team is able to generate alternative concepts for building form, envelope and landscaping, and also focus on

minimizing peak energy loads, demand and consumption. Design alternatives are aimed at minimizing the buildings' construction cost and its life-cycle cost and their evaluation is on the basis of capital cost as well as reduced life-cycle cost. Assessments include costs and environmental impacts of resource extraction; materials and assembly manufacture; construction; operation and maintenance in use; and eventual reuse, recycling or disposal. Computer energy simulation is but one of the tools used to incorporate operational costs into the analysis. Computer energy simulation is also employed to evaluate a project's effectiveness in energy conservation, and its construction costs. Typically, heating and cooling load reductions from better glazing, insulation, efficient lighting, daylighting and other measures allows smaller and less expensive HVAC equipment and systems, resulting in little or no increase in construction cost compared to conventional designs. The use of simulations to refine designs and ensure that energy-conservation and capital cost goals are met is extremely valuable; and to demonstrate regulatory compliance. For this reason simulations are necessary to guarantee the projects overall success.

In conventional, non-green buildings, the different specialties associated with project delivery, from design and construction through building occupancy, are responsive in nature, utilizing restricted approaches to address particular problems. Each of these specialties typically has wide-ranging knowledge and experience in their specific fields, and they provide solutions to problems that arise solely based on their knowledge and experience in their specific fields. For example, an air-conditioning specialist if asked to address a problem of an unduly warm room will suggest increasing the cooling capacity of the HVAC system servicing that room, rather than investigate the source of the problem of why this room is unduly warm. The excessive heat gain could, for example, be mitigated by incorporating operable windows or external louvers. The end results therefore while often being functional is nevertheless highly inefficient so that the building ends up comprising of different materials and systems with little or no integration between them.

With integrated design, you typically have properly engineered and functioning systems that help ensure the comfort and safety of building occupants. They also empower designers to create environments that are healthy, efficient and cost-effective. Integrated design is a critical factor and consistent component in the design and construction of green buildings. The summary description outlined below highlights the benefits of integrated design and the main attributes and characteristics that differentiate

conventional and integrated design process. Being able to keep the goals and objectives for the project in mind throughout design and construction process is certainly one of the unique benefits of integrated design.

3.3.4 Putting Together the Integrated Multidisciplinary Project Team

As mentioned earlier, the design of green buildings requires the integration of many kinds of information into a well-designed, useful, and resilient whole. According to the World Building Design Guide (WBDG), “An integrated design process includes the active and continuing participation of users and community members, code officials, building technologists, contractors, cost consultants, civil engineers, mechanical and electrical engineers, structural engineers, specifications specialists, and consultants from many specialized fields.” It is important therefore that all members of the multi-disciplinary team collaborate closely, from the beginning of conceptual design, and throughout the design process and construction. For sustainable projects the design team usually has to broaden itself to include certain specialists and other interested parties, such as energy analysts, BIM specialist, materials consultants, cost consultants, and lighting designers; often, contractors, operating staff and prospective tenants are also included. This enlarged design team provides fresh perspectives reflecting new approaches, and feedback on performance and cost. The design process becomes a continuous, sustained team effort from conceptual design through commissioning and occupancy.

In most building projects, the architect is required to lead the design team and coordinate with sub-consultants, and other experts, etc. The architect is also required to ensure compliance with the project brief and budget. In some cases, the architect has the authority to hire some or all of the sub-consultants; in larger projects the owner may decide to contract directly with some or all of them. The architect usually administers and manages the production of the contract documents and oversees the construction phase of the project, ensuring compliance with the contract documents by conducting appropriate inspections, and managing submissions, approvals, and evaluations by the sub-consultants. The architect also oversees the evaluation of requests for payment by the builder and other professionals and chairs monthly or bi-weekly site meetings. Depending on the size and complexity of the project, the owner may hire a BIM manager whose role and responsibilities will need to be clearly defined.

Involvement at the earliest phases of the project of the *civil, structural, mechanical and electrical engineers* is imperative as they are an integral part of

the project team and essential for achieving a total understanding of the various regulatory and other aspects (e.g., structural, heating, ventilation and air-conditioning, etc.) of the construction project; these consultants may be hired directly by the owner or the architect. Each consultant produces that portions of the contract documents that is within his/her specialty and all participate in assessing their part of the work for compliance with those contract documents.

A *landscape architect* may be hired as an independent consultant depending on the type and size of the project. If a landscape architect is employed, this should be early in the design process to assess existing natural systems, how they will be impacted by the project and ways to facilitate accommodation of the project to those systems. The landscape architect will also organize the arrangement of land for human use involving vehicular and pedestrian ways and the planting of groundcover, plants, and trees. This requires extensive experience in sustainable landscaping including erosion control, managing stormwater runoff, green roofs, and indigenous plant species.

Other specialized consultants may be required and as with all contributors to the integrated design process, these consultants should be involved early in the design process to combine their suggestions and requirements in the design so as to guarantee that their contributions are taken into account to ensure maximum efficiency.



3.4 THE DESIGN PROCESS FOR HIGH PERFORMANCE BUILDINGS

Today we are witnessing a rapidly changing world in which building construction practices and advances in architectural modeling technologies have reached a unique crossroad in history with changing needs and expectations. And with many successful new building projects taking shape globally, it calls into question the performance level of many of our more typical construction endeavors, forcing us to reevaluate just how far our conventional buildings are falling short of the mark and what needs to be done to meet these new challenges. High performance outcomes necessitates a far more integrated team approach to the design process and marks a departure from traditional practices, where emerging designs are handed sequentially from architect to engineer to sub-consultant (Fig. 3.6 a,b). As mentioned above, an integrated holistic approach results in a typically more unified, more team-driven design and construction process that

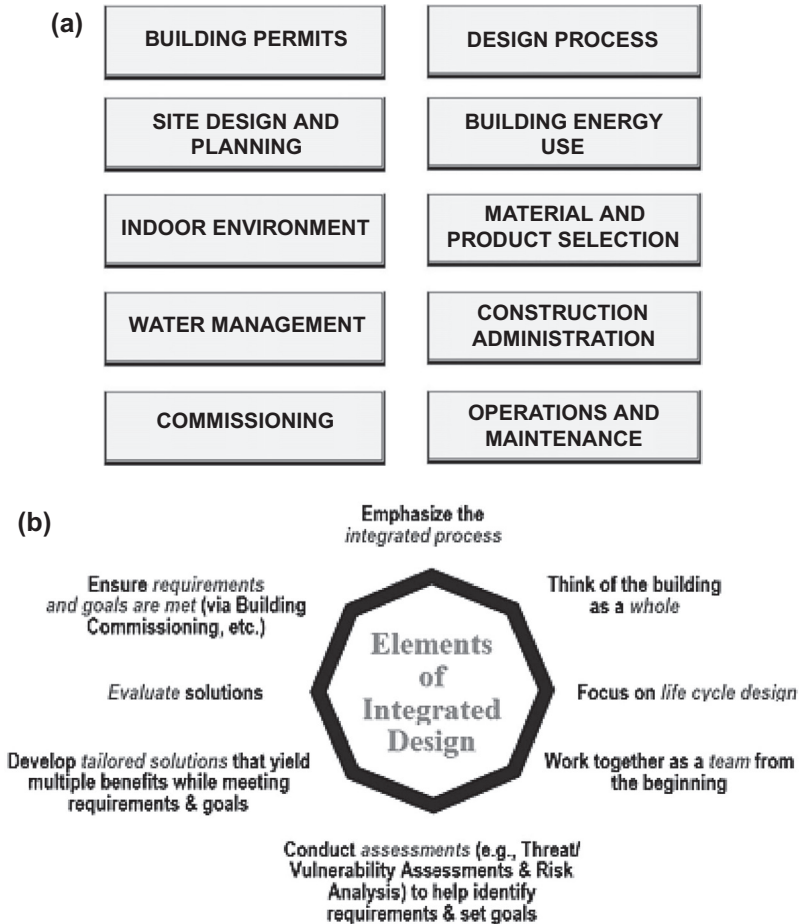

Figure 3.6 (a) Main elements of high performance building design. (b) The Integrated Design Process. Diagram depicting the standard operation of the integrated project team.

encompasses different experts early in the design setting process. This process increases the likelihood of creating high performance buildings that achieve significantly higher targets for energy efficiency and environmental performance than traditionally designed buildings.

The best buildings result from active, consistent, organized collaboration among all players which is why in the absence of an interactive approach to the design process it would be extremely difficult to achieve a successful high-performance building. The process draws its strength from the knowledge and expertise of all the stakeholders (including the owner) across the

life cycle of the project in addition to their early collaborative involvement in recognizing the need for the building, through planning, design, construction, operation, and maintenance of the facility and building occupancy is part of this process. Also, by implementing a team-driven approach high performance buildings are basically utilizing a “front-loading” of expertise. The process typically begins with the consultant and owner leading a green design charrette with all the stakeholders (design professionals, operators, and contractors) in a brainstorming session reflecting a “partnering” approach that encourages collaboration in achieving high performance green goals for the new building, while breaking down traditional adversarial roles.

By implementing best practices guidelines and an integrated team-driven approach we maximize the likelihood of achieving superior results in the building design and construction of a project. The application of integrated design methods elevates energy and resource efficiency practices into the realm of high performance. This approach differs from the conventional planning and design process of relying on the expertise of various specialists who work in their respective specialties somewhat isolated from each other. The integrated design process on the other hand encourages designers from all the relevant disciplines to be collectively involved in the design decision-making process and to work together in harmony to achieve exceptional and creative design solutions that yield multiple benefits at no extra cost.

Design charrettes can be very instrumental in complex situations where the interests of the client often conflict particularly when they are represented by different factions. Charrette team members are expected to discuss and address problems beyond their field of expertise. Although final solutions may not necessarily be produced, important interdependent issues are often studied and clarified. Conducting a facility performance evaluation to confirm that all the designated high-performance goals have been met and will continue to be met over the life cycle of the project is also an important consideration. Retrocommissioning is another factor that should be considered to ensure that the building will continue to optimally perform through any potential adjustments and modifications in the future.

It has been clearly stated earlier in this chapter, that when computer energy simulations are conducted, they should be as early as possible in the design process and continue until the design is complete, to offer a reliable assessment of energy conservation measures and to allow the design team to generate several alternative concepts early in the process for the building’s form, envelope and landscaping. Computer energy simulation has proven

to be an excellent tool to assess the project's effectiveness in energy conservation, as well as its construction costs. Employing sustainable approaches that reduce heating and cooling loads allows the mechanical consultant to design a more appropriate, more efficient and less expensive HVAC system thus resulting in minimal if any increase in construction cost compared to conventional designs.

Computer simulations have many positive attributes such as allowing us to see how a design can be improved and to ensure that energy-conservation and capital cost goals are met, in addition to checking that a design complies with all regulatory requirements. Furthermore, alternative design proposals can be created and readily evaluated either on capital cost or on the basis of reduced life-cycle cost. The primary aim of exploring alternative designs is to simultaneously minimize both a buildings' construction cost and its life-cycle cost. But in order to more accurately assess these costs requires a comprehensive approach that includes accurate information on costs and environmental impacts on all aspects of construction including resource extraction and materials and assembly manufacture. It also requires costs relating to operation and maintenance in use to final reuse, recycling and disposal. There are several computer tools that are available to facilitate performing life-cycle cost analysis such as computer energy simulations that can be employed to incorporate operational costs into the analysis.

The awe and admiration of high performance sustainable buildings are witnessing a dramatic upsurge in the property development market and moreover, is emerging as an important market sector both in the United States and globally. At the same time this increased demand for high performance buildings has encouraged facility owners, investors and design professionals to reevaluate their position with regard to high performance buildings and the integrated design process. This reassessment of emerging patterns and primary processes on successful high-performance building projects is having a consequential impact on both the private and government sectors.

Many government agencies have started to take a serious approach to sustainability, and in January 2006, a Federal Leadership in High Performance and Sustainable Buildings Memorandum of Understanding (MOU) was signed, for which the signatory agencies commit to federal leadership in the design, construction, and operation of High-Performance and Sustainable Buildings. An important component of this strategy is the implementation of prevalent approaches to meet certain requirements relating to various sustainable activities such as planning, siting, designing, and building, operating, and maintaining high performance buildings. The MOU contains a number of

guiding principles to be adopted by federal leadership in high performance and sustainable buildings. These incorporate greater detailed guidance on the principles for optimizing energy performance, conserving water, improved IEQ, integrated design, reducing the impact of materials and other issues. Since the signing of the MOU many federal facilities have already succeeded in creating high performance buildings that save energy and reduce the negative impact on the environmental and people throughout the United States.

The Interagency Sustainability Working Group (ISWG), as a subcommittee of the Steering Committee established by Executive Order (E.O.) 13423, initiated development of the guidance to assist agencies in meeting the high performance and sustainable buildings goals of E.O. 13423, Section 2(f). When the December 05, 2008 guidance on high performance federal buildings was originally issued, it included:

- Revised Guiding Principles for new construction
- New Guiding Principles for existing buildings
- Clarification of reporting guidelines for entering information on the sustainability data element (#25) in the Federal Real Property Profile
- Clarification and explanation of how to calculate the percentage of buildings and square footage that are compliant with the Guiding Principles for agencies' scorecard input

Whether and how this guidance will be impacted by the new national green codes that have been recently issued is not clear.

The latest update is *The Federal Energy Management Program (FEMP)* which provides guidance to help agencies comply with the 2016 Guiding Principles for Sustainable Federal Buildings, which were issued by the Council of Environmental Quality (CEQ) on February 26, 2016.

The FEMP states that there are "Six Guiding Principles apply to existing buildings and new construction or modernization:

- Employ integrated design
- Optimize energy performance
- Protect and conserve water
- Enhance indoor environmental quality
- Reduce environmental impact of materials
- Assess and consider climate change risks."

These Guiding Principles are used by the Office of Management and Budget to score federal agencies' progress and compliance within the "Green Buildings" category on the agency's annual scorecards. It should be noted that the 2016 Guiding Principles (as of February 26, 2016) update and replace the original December 2008 version with the intent to echo

the evolution of sustainable building design, construction, and operating practices since the 2008 Guiding Principles, and to better incorporate other building-related Executive Order 13693 requirements. This reflects the Federal government's commitment to lead by example in curbing the greenhouse gas (GHG) emissions that are driving climate change; to this end, President Obama signed Executive Order (EO) 13693 on February 19, 2015. It is estimated that the EO will cut Federal GHG emissions by 40% over the next decade from the 2008 levels—saving taxpayers an estimated \$18 billion in avoided energy costs—while increasing the share of electricity the Federal Government consumes from renewable sources to 30%.



3.5 GREEN PROJECT DELIVERY SYSTEMS

Selecting the most appropriate project delivery system will typically be determined by the owner during the concept design phase. Each delivery system has its characteristic advantages and disadvantages depending on the type and size of the project under consideration. Indeed, selection of the right project delivery system is one of the most significant factors that impact a construction project's ability to succeed. But before making a final determination on the delivery system to be employed, the owner will need to have a proper understanding of the attributes and challenges of the different systems. Project delivery is simply a process by which all of the processes, procedures and components of designing and building a facility are organized and incorporated into an agreement that results in a completed project. The process begins by fully stating the needs and requirements of the owner in the architectural program from concept design to final contract documents. There are a wide range of construction project delivery systems. In this respect, Barbara Jackson, author of *Construction Management Jump Start*, says "there are basically three project delivery methods: design-bid-build, construction management, and design-build." Jackson goes on to say, "These three project delivery methods differ in five fundamental ways:

- The number of contracts the owner executes
- The relationship and roles of each party to the contract
- The point at which the contractor gets involved in the project
- The ability to overlap design and construction
- Who warrants the sufficiency of the plans and specifications

Regardless of the project delivery method chosen, the three primary players – the owner, the designer (architect and/or engineer), and the contractor – are always involved."

Deciding on what project delivery approach is the most appropriate for a given project may be the single most pressing question in many owners' minds. To attempt to answer this question, the owner must first define and prioritize how to measure the project's success and choose a project delivery approach that will take the project in that direction. The expectation is that the delivery system chosen will produce the highest quality and most efficient project at the lowest cost and earliest time. But whichever system is chosen, the owner must maintain realistic expectations and not expect perfection as no project delivery approach is perfect nor can any guarantee a perfect project. The project delivery approach that is chosen by the owner will determine the expected trade-off between the owner's control of the project delivery process and the anticipated risks that come with this decision. Likewise, the owner's project delivery choice will also govern the amount of involvement, both in time and expertise, required of the owner to make the project delivery successful. This has prompted many owners especially on large or complex projects to engage design and construction professionals as independent advisors to assist them in making informed decisions and meet these demands. While these professionals advise, serve and represent the owner, they should have no other interest in the project other than the protection of the owner. Conflict of interest must be avoided at all costs.



3.6 TRADITIONAL GREEN DESIGN-BID-BUILD PROJECT DELIVERY

In most countries around the world, the traditional Design/Bid/Build (DBB) delivery method has been the approach of choice in both public and private construction projects. It remains the project delivery system that is most widely used today and which is still required by some states. And because of its long history, the design-bid-build method is well understood by the majority of owners, contractors and industry professionals. With this delivery system, risk is minimized through the owner's control and oversight of both the design and construction phases of the project. The design-bid-build process usually provides the lowest first costs based on submitted tenders, but takes the longest time to execute. However, this method has been somewhat modified in addition to increasing complexity by the inclusion of green/sustainability features into the equation.

Thus, when employing the traditional project delivery system, the owner contracts separately for the design and construction of the project to a planned budget. The owner will typically contract directly with a design

professional for complete design of the project including contract documents and professional assistance during the bidding stage. The design professional often provides project oversight and continues to administer the construction phase of the project on behalf of the owner. This involves reviewing shop drawing submittals, monitor construction progress and check payment requests as well as processing contractor RFI's re the construction documents and addressing change order requests. When the plans and specifications (bidding documents) are complete, they are released for bidding and solicitation of tenders to prequalified contractors. Prequalification requires certain information that facilitates the selection of potential constructors. This information includes proof of past experience in similar work, financial capability, a record of exemplary performance by responsible references and current work in hand to ensure that the contractor is not overloaded.

Allegations of owner favoritism (whether real or perceived) in the selection process can be largely eliminated by allowing all qualified contractors to tender on an equal low-bid basis. The design of the project must be completed prior to contractor bidding and selection. Once the general contractor is selected (normally through a competitive bid process) which in most cases is the lowest acceptable bidder, the owner enters into a separate contract with the general contractor to build the project. This process is generally perceived to be a fair process for contractor selection for the project. Under the design-bid-build project delivery system, the owner retains overall responsibility for project management and all contracts are generally executed directly with the owner. When a lump sum price is agreed to between owner and contractor, the owner can usually rely upon the accuracy of the price and is able with the assistance of the consultant designer to compare submitted bids to ensure that the best contract price has been obtained. It should be noted that there is no legal agreement between the contractor and the designer of record.

The design-bid-build process has several important advantages; e.g., it provides much needed checks and balances between the design and construction phase of the project. It also provides the owner with the ability to provide significant input into the process throughout the project's design phase. The traditional design-bid-build process also has some disadvantages, the main one being that it is a lengthy and time-consuming process and the owner often has to address disputes that may arise between the contractor and the design professionals due to errors or other unexpected circumstances. With this process the ultimate estimated cost of construction is unknown until bids are finalized, bearing in mind that the system encourages

potential change orders which will most likely increase costs. Moreover, there is no builder input during the design process which opens the project to potential change orders. Also, there is zero owner involvement through the bid process and normally the general contractor selects all subcontractors, although generally there is no contractor buy-in to green process and concepts. However, there is always the risk with this system that construction bids exceed the project's stated budget (because plans and specifications are completed prior to tendering the project), the consequence of which is either being forced to abandon the project altogether or having to redesign it to fit within the available budget. Another important consideration with this type of delivery system is that the owner is normally required to make a significant financial up front commitment in order to have a complete design in hand as part of the contract documents before solicitation of tenders. According to Petina Killiany, Associate Vice President of PinnacleOne, a leading construction consulting firm the design/bid/build approach is generally best suited for projects that meet certain requirements such as:

- The owner desires the protection of a well-understood design and construction process;
- The owner desires the lowest price on a competitive bid basis for known quantity and quality of the project;
- The owner has the time to invest in a linear, sequential, design/bid/build process;
- The owner needs total design control.

Killiany also maintains that there are certain project success factors that owners sacrifice when using the design/bid/build approach which are, "First, because there is no input from the contractor during the design phase, their input is lost on what may provide the best value in the trade-off between scope and quality. The construction contract is usually performed on a lump sum basis, any savings are not returned to the owner. Design/bid/build projects normally do not allow for fast track design and construction, and as a result, can take more time than those delivered by other approaches." It should be noted that should gaps be discovered between the plans and specifications and the owner's requirements, or errors and omissions are found in the design, it is the owner's responsibility to pay to rectify these mistakes.



3.7 GREEN CONSTRUCTION MANAGEMENT

The ASHRAE Green Guide states that, "The construction manager method is the process undertaken by public and private owners in which a firm with extensive experience in construction management and general

contracting is hired during the design phase of the project to assess project capital costs and constructability issues.” This project delivery system is a process by which a “construction manager” is added to the construction team to oversee some or the whole project independent of the construction work itself. The CM’s role and responsibilities should be clearly defined. For example, it can be to oversee aspects of the project such as scheduling, cost control, the construction process, safety, the CxA, bidding, or oversee all aspects of the project until final completion.

Joseph Hardesty of Stites & Harbison PLLC says, “In many ways, the construction management process is not, by itself, a separate construction delivery system but is a resource the owner can use to assist in the construction project. The added cost of a construction manager must be weighed against the benefits this consultant brings to the project. Often, the architect can fulfill the role provided by a construction manager. However, depending upon the degree of sophistication of the owner’s in-house construction staff, and depending upon the complexity of the project, a construction manager can provide an essential element to the construction project.” Hardesty goes on to say, “A construction manager is most useful on a large, complex project which requires a good deal of oversight and coordination. A construction manager is also helpful to an owner who does not have a sophisticated in-house construction team. A construction manager can help the owner control costs and avoid delays on complex projects.”

The two basic types of construction management to consider under this method are: (1) The agency CM and (2) The at-risk CM (sometimes called CM/GC).

1. The *agency* CM is a fee-based service in which the CM acts as advisor to the owner and is exclusively responsible to the owner and acts on the owner’s behalf throughout the various stages of the project. The owner will separately commission the general contractor and designer of record. With this method the CM basically acts as an extension of the owner’s staff and assumes little risk except for that involved in fulfilling its advisory roles and responsibilities. With this method the general contractor remains responsible for the construction work and still carries out construction management functions relative to their internal requirements for managing the project to completion. However, the agency CM is not at risk for the budget, the schedule or the project’s performance nor does the CM contract with subcontractors.
2. The *at-risk* CM delivery approach does not differ significantly to the traditional design/bid/build method in that the CM replaces the general contractor in this scenario during the construction phase and commits

to delivering the project on time and within a guaranteed maximum price (GMP). The CM holds the risk of subletting the construction work to trade subcontractors and guaranteeing completion of the project for a fixed price negotiated at some point either during or upon completion of the design process. However, unlike design/bid/build, during the development and design phases the at-risk CM's role is chiefly advise the owner on relevant issues.

It is the duty of the owner to weigh the relative advantages and disadvantages of each construction delivery system prior to beginning the project. Petina Killiany lists some of the at-risk CM advantages over design/bid/build delivery system:

- Because construction can often begin before the design is complete, the overall project duration can be shorter;
- The owner generally gets better estimates of the ultimate cost of the project during all phases of the project;
- The owner benefits from a contractor perspective in making decisions on the trade-offs during the design phase between cost, quality, and construction duration;
- Constructability and design reviews by the contractor prior to bidding often result in better designs and lower trade contractor contingencies and bids;
- The expertise of the CM in pre-qualifying trade contractors helps achieve better performance and workmanship by the trades;
- The architect and contractor working together during the design portion can result in a better team effort after the GMP is established.

However, in some jurisdictions the at-risk CM approach faces the possibility of not being permitted by statute to a public owner. Also, not being a traditional method of delivery, some owners may not fully understand how to successfully implement this method, and as a result, feel forced to rely on the advice of the CM when they should in fact be questioning it. Moreover, the owner should consider the size and complexity of the project, the relative importance of cost or schedule and the in-house expertise the owner has to manage the project before deciding whether this delivery method is appropriate for the project.

It should be noted that when the Project Management/CM is engaged in an advisory capacity the service is totally different, for while project owners can't totally avoid risks, it is possible to mitigate them to an acceptable level. Richard Sitnik a Senior Project Manager with Pinnacle One says, "When given appropriate responsibility and the ability to provide effective

leadership, Project Managers/CMs as Advisors promote project success through informed, experience-based decision making, and well-disciplined and regimented project controls.” Sitnik also opines that the Project Manager/CM as advisor can provide a wide range of services to the owner throughout the design, bidding, negotiation, and construction phase of the project. Below are some of the more pertinent services outlined by Sitnik:

- perform needs assessments
- provide direction on alternate project delivery systems
- assist in the selection of appropriately qualified consultants
- manage governmental agency approvals
- identify and manage risks
- anticipate potential problems before they become costly
- produce master budgets and schedules
- establish project controls
- control costs
- perform quality controls

The greatest value of engaging a Project Manager/CM as Advisor occurs when he/she is engaged very early in the design process to initiate the establishment of controls, including budgets and master schedules. This will not only contribute to greater design efficiency, but also to fewer change orders in the field and less likelihood of surprises to the owner on bid day. The principal role of the Project Management/CM as advisor is to minimize delays, cost overruns, and a failure to meet project objectives. This can be achieved by basically providing the owner with total support and impartial advice and counsel, and guiding the owner to make informed decisions, without comprising the ability to coordinate the multiple agendas and sometimes conflicting interests of the design professionals, contractors, and owners.

On occasion the term “Program Management” is used which is essentially the same service as Project Management/CM as Advisor, the distinction being that Program Management is the term used when applied to large, complex, and multi-project programs. The general benefit to the owner in employing a Program Manager is the expertise and experience these firms bring to the table such as assisting the project owner develop an appropriate overall strategy to manage projects within the program, as building projects may differ in their requirements and method of construction. When Program Managers oversee processes that consist of more than one building, then allocation of the various roles may differ so that e.g., one building/project may comprise of an

architect, general contractor, and a Project Manager/CM as Advisor, while a design-builder or at-risk CM may construct another project within the program. However, all construction projects are always likely to contain some risk, and employing a Program Manager and/or a Project Manager/CM as advisor would minimize this risk and should be seriously considered for large or complicated projects, particularly in cases where owner is faced with the risk and responsibility of choosing and implementing a project delivery approach, but lacks appropriate in-house technical capability or who needs an increase in staff when timeframes restrict their use.



3.8 GREEN DESIGN-BUILD PROJECT DELIVERY

There are several definitions of the design-build process. The Design-Build Institute of America (DBIA) describes this method as “an integrated delivery process that has been embraced by the world’s great civilizations. In ancient Mesopotamia, the Code of Hammurabi (1800 BC) fixed absolute accountability upon master builders for both design and construction. In the succeeding millennia, projects ranging from cathedrals to cable-stayed bridges, from cloisters to corporate headquarters, have been conceived and constructed using the paradigm of design-build.”

One of the distinguishing features of the design-build approach is that there is only one contract, meaning that the owner contracts with one entity (the designer/builder) that will assume responsibility for the entire project, i.e., its design, supervision, construction and final delivery. The selection process usually consists of soliciting qualifications and price proposals from various design/builders, usually teams of contractors and designers, before or during the conceptual design phase of the project. The design-build team is generally led by a contractor (often with a background in engineering or architecture), resulting in the owner issuing a single contract agreement to the contractor, who in turn contracts with a designer for the design. According to Killiany, design-build when permitted is generally suited for projects in which:

- The owner is willing to forego control of design and does not seek a highly complex design program/solution
- The owner can provide a complete definitive set of performance specifications and program for design for the design/builder to serve as the basis for the design/builder’s proposal and the owner’s contract with the design/builder

- The owner has realistic expectations for the end-product and a thorough understanding of risk giving up the control of the design
- The owner desires a fast delivery method and is willing to compensate the design-build team for its assumption of risk for design and construction.

3.8.1 Design-Build Process Basics

Many project owners prefer the design-build project delivery system to the design-bid-build system because it provides a single point of responsibility for design and construction rather than having to contract separately for the design phase and then for the construction with two separate entities which may also be the reason it is gaining popularity as the project delivery system of choice (Fig. 3.7a). Although it has the advantage of removing the owner from contractor and design disputes, it has the disadvantage of eliminating some of the checks and balances that often occur when the design and construction phase are contracted separately. Other disadvantages for the owner include the loss of much of the control of the project that exists under a design-bid-build process, and the owner/architect advisory relationship that exists in the design-bid-build process which sometimes results in the project not meeting the owner's expectations.

Nevertheless, interacting with a single entity has obvious advantages for the owner, such as easier co-ordination and more efficient time management. The design-build contractor or firm will endeavor to streamline the entire design process, construction planning, obtaining permits, etc. One advantage with the design-build process is the ability to overlap activities so that certain construction activities on parts of the project can begin even before finalization of the design. There are times, when the main contractor may involve other organizations on the project with him, but in such cases too, the contractor will be the one dealing with them and assume responsibility. This overlapping offers flexibility to make changes to the design, while construction is in progress. With the traditional design-bid-build system, this isn't possible, since construction cannot begin prior to finalization of the blueprints and contract documents (Fig. 3.7b).

According to the Design-Build Institute of America (DBIA), an organization that defines, teaches and promotes best practices in design-build, recently released research shows that design-build project delivery systems embody close to 40% of the total market share in the United States, based on dollar value at the end of 2012. This represents an 8% increase since 2005. The research also shows that the Military sector clearly dominates design-build project delivery systems with an 81% market share.

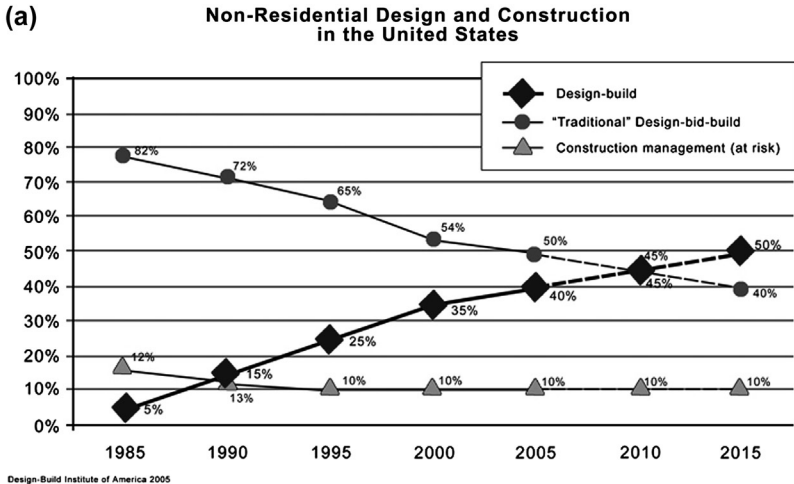

(b) Design-Build Contract Relationships

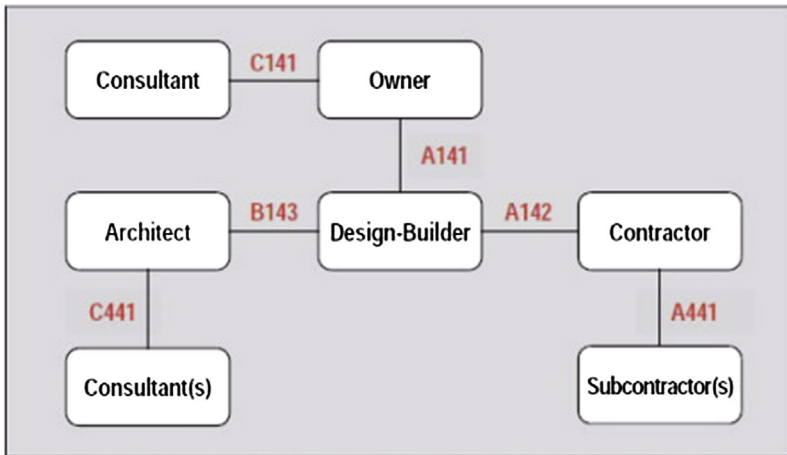

Figure 3.7 (a) Graph showing the rising popularity of Design-Build in non-residential construction in the United States over the years. (b) Design-Build Contract Relationships: Documents: AIA Documents A141, Owner/Design-Builder Agreement; A142, Design-Builder/Contractor Agreement; A441, Contractor/Subcontractor Agreement for a Design-Build Project; B143, Design-Builder/Architect Agreement; C141, Owner/Consultant Agreement for a Design-Build/Project; and C441, Architect/Consultant Agreement for a Design-Build Project. Source: (a) Design Build Institute of America (b) American Institute of Architects.

3.8.2 The Advantages and Disadvantages of Design-Build

There are several important potential advantages and disadvantages for the numerous parties involved in a design-build contract, especially if all the parties correctly understand the mechanics of the process as it applies to their project. Kenneth Strong and Charles Juliana of Gordon and Rees LLP, lists some of the advantages and disadvantages below:

A. Design-Build Advantages

1. **Time Savings:** By combining the selection of a designer and a contractor into one step, the design-build method eliminates the time lost in the DBB process. Further, the design-build contractor is able to start construction before the entire design is completed. For instance, the design-build contractor can start excavation as soon as the foundation and utility relocation design has been prepared. Meanwhile, the design professional can continue design work for the rest of the project during excavation.
2. **Cost Savings:** Potential costs savings can be realized with the design-build system because it has high value engineering capabilities due to the close coordination between the A/E and construction contractor. Construction contractors have direct and real experience with the cost of purchasing and installing materials and, in the design-build system, can share that experience directly with the design professional during the Design Phase of the project. This process has the potential to translate into lower costs which savings can then be passed on to the owner.
3. **One Point of Contact:** The one point of contact feature for both design and construction is integral to the design-build system. The advantages of this feature are relative - having only one entity to deal with in many instances will outweigh the oversight benefits an owner would otherwise get from contracting separately with a design professional for the project design.
4. **Fewer Change Orders:** A definite advantage of the design-build system is that an owner can expect far fewer change orders on a design-build project. However, if an owner decides it wants a design change during the design-build project, and, that change is not covered by the defined scope of the project, that would be considered an extra. Still, in the design-build system, the owner is not liable for any errors the design professional makes because the design professional is part of the design-build team.

5. **Reduced Risk to the Owner:** The shifting of liability for design quality from the owner to the design-build contractor is one of the most significant features of the design-build project delivery system. The advantage to the owner is that it now knows from the outset the cost of that risk. As the design-build contractor is in a better position than the owner to manage and minimize that risk, this is a significant advantage of design-build contracting.
- B. Potential Disadvantages to using the Design-Build Method**
1. **Loss of Control of Project Design:** In the design-build system, the shift in responsibility for the design from the owner to the contractor implicitly includes some shift in control. The owner should evaluate the degree to which this loss of control will affect the success of the project. If the owner has specific needs or requirements, it should satisfy itself that it can clearly articulate them in defining the scope of work, or accept the risk that it will have to pay extra to get what it wants via the change order process. Change orders issued to revise scope are not inherently less likely or less expensive in the design-build project delivery method.
 2. **Less Project Oversight/Control of Quality:** As has been discussed, one of the advantages of the design-build concept is the cooperation between the design professional and the construction contractor because they both are part of the same team: the design-build contractor. However, this feature can also be a disadvantage, as the architect is no longer the owner's independent consultant and is now working with and for the contractor. For owners who do not have their own design-proficient staff, the loss of the architect's input and judgment may expose them to quality control problems. The owner considering design-build project delivery ignores this issue at its peril. If the owner is one that is used to having the design professional act as its agent, it should make plans to have another entity take that responsibility.
 3. **Suitability of Design-Build Teams:** In the DBB methodology, while public agencies are bound by state law to hire the lowest responsive, responsible bidder for construction work, they have more flexibility in selecting designers for their projects. In other words, DBB public owners are allowed to take into account in the selection of a designer more than simply which candidate offered the lowest price. In design-build, the public owner loses the latitude it had in DBB in selecting a design firm. True, the risk for adequacy of the design has

been shifted to the design-build contractor, but that is little solace to an owner if the finished project is structurally sound but operationally deficient.

Other potential challenges or disadvantages include difficulty in pricing the work. It is often difficult to establish a firm price for a project if the design is incomplete which often reflects the situation when the design-build organization is selected. Costly tendering is another issue. Owners are usually expected to pay for the efforts by design-build organizations to formulate their tenders which normally may include preliminary design work in order to be able to present a cost estimate for the project.

3.8.3 Factors That Impact the Decision to Choose Design-Build

Before deciding whether the design-build methodology is the most appropriate delivery system for a given project, the following factors should be taken into consideration:

- Design-build is an appropriate project delivery system for projects that needs to be completed within a tight time frame.
- An important factor that will impact the delivery system selection is the type of project to be constructed. An appropriate candidate for design-build is a project where the performance and form of the finished project is sufficiently described in a scope document. However, the design-build may not be the best method to adopt in a project in which the owner's needs are very specific and specialized.
- Several cost saving benefits in terms of the budget can be achieved using the design-build system, in addition to cost savings achieved by shifting more cost control responsibility to the contractor. For example a construction contractor may wish to use certain materials and methods that meet the owner's requirements but were not originally considered by the designer. Any potential cost savings that may accrue from the contractor's proposed modifications should be passed on to the owner rather than the contractor.

3.8.4 AIA Design-Build Documents

The construction industry has witnessed over recent decades, the steady increase in popularity of the design-build project delivery system on vertical construction projects. Project owners and contractors however, have displayed rising concern that the standard AIA forms of agreement for design build projects did not adequately address their needs. In direct response to

these concerns, the AIA decided to completely overhaul the design-build forms of agreement which resulted in the introduction of several completely new forms of agreement and the retirement of the 1996 series (the A191, A491 and the B901) of agreements.

The new agreements include the AIA A141-2014 Agreement Between Owner and Design-Builder (replaces A141TM-2004 which replaces A191-1996); The AIA Document A142-2014 replaces AIA Document A141-2004, Standard Form of Agreement Between Design-Builder and Contractor, and consists of the Agreement portion and four exhibits: Exhibit A, Terms and Conditions; Exhibit B, Insurance and Bonds; Exhibit C, Preconstruction Services; and Exhibit D, Determination of the Cost of the Work. The previous A142-2004 Agreement Between Design-Builder and Contractor (replaces A491-1996); the B142-2004 Agreement Between Owner and Consultant where the owner contemplates using the Design-Build method of project delivery (no 1996 counterpart); the B143-2004 Agreement Between Design-Builder and Architect (which B143-2004 Agreement Between Design-Builder and Architect which in turn replaces B901-1996); the G704-2004 Acknowledgment of Substantial Completion of a Design-Build Project (no 1996 counterpart). The G744-2014, is the Certificate of Substantial Completion for a Design-Build Project. Because of the nature of design-build contracting, the project owner assumes many of the construction contract administration duties performed by the architect in a traditional project. Because there is not an architect to certify substantial completion, AIA Document G744-2014 requires the owner to inspect the project to determine whether the work is substantially complete in accordance with the design-build documents and to identify the date when it occurs. AIA Document G744-2014 is a variation of AIA Document G704-2000 and provides a standard form for the owner to certify the date of substantial completion.

In 2008 the AIA also published AIA Document A441-2008, Standard Form of Agreement Between Contractor and Subcontractor for a Design-Build Project, and AIA Document C441-2008, Standard Form of Agreement Between Architect and Consultant for a Design-Build Project.

C141-2014 (formerly B142-2004), Standard Form of Agreement Between Owner and Consultant for a Design-Build Project. According to the AIA, the AIA Document C141-2014, provides a standard form for the upfront services an owner may require when considering design-build delivery. The consultant, who may or may not be an architect or other design professional, may perform a wide ranging array of services for the

owner, including programming and planning, budgeting and cost estimating, project criteria development services, development of bridging documents, conducting construction, and administration services. AIA Document C141-2014 consists of the agreement portion and one exhibit, Exhibit A, Consultant's Services. Exhibit A provides a menu of briefly described services that the parties can select and augment to suit the needs of the project. Note: AIA Document B142-2004 expired on December 31, 2015.

It is true that the design-build form of delivery system has several advantages for building owners, yet they have come to realize and understand that with this system, they exercise less overall control in guaranteeing that the owner's "intent" is clearly articulated and this has been a great cause for concern. From this concern emerged a concept known as "Bridging" which is discussed in greater detail in [Chapter 14](#) (Types of Building Contract Agreements); it is defined as the owner's means of conveying its intent to the design-build team, and can take on various forms so that the owner can assume a more expansive role, in which the owner can provide much greater input in the design, or alternatively the owner can assume a more restricted role, and simply set forth its intent in a more conceptual form.



Green Project Cost Monitoring and Closeout



4.1 OVERVIEW

The primary objectives of any project are to ensure that it is completed on time, within the budget and according to specifications. The Project Management Institute (PMI) defines project management as “the art of directing and coordinating human and material resources throughout the life of a project by using modern management techniques to achieve predetermined objectives of scope, cost, time, quality, and participating objectives.” However, in the case of construction project management, one can take PMI’s definition and insert it into a construction context for a definition of a construction project manager.

Moreover, in addition to lenders, there are several other manor players including owners, contractors, architects/engineers, and material or equipment suppliers that are typically involved in the construction of new facilities and major renovations, and who together try and achieve these objectives. The borrower who is typically the project owner is often required to present the Lender with conceptual designs and specifications, proformas, construction cost estimates, etc., for the primary purpose of providing enough information to enable the lending institution to make a loan determination. Upon receipt of the various drawings and documents, the Lender usually hires a Construction Consultant to advise and get a professional objective review of the construction loan commitments and payments requests to fully protect the lending institution. The Construction Consultant then examines all the documents on behalf of the Lender, including the conceptual design and specifications, and contract documents for engineering soundness and compliance with governmental regulations. An assessment of cost comparables is then made for similar projects, in addition to a trade-by-trade breakdown. Upon completion, this estimate is compared with the borrower’s estimate for general agreement and discrepancies.

Of note, the lender’s interest in each property is subject to rights and restrictions stated and articulated in the loan documents. In the case of new

construction, the Consultant is usually hired by the Lender prior to commencement of the project and basically has the responsibility of administering the project to completion. The Consultant therefore assumes that satisfactory access to the property, staff, vendors, and documents will be provided by the borrower. In the event the borrower fails to cooperate, the Lender will apply its leverage to assist administrator in securing access and all information necessary to monitor the project and to protect the Lender's rights. On no account should a Lender's representative seek access to any property, staff, vendor, or documents if the borrower refuses such access or restricts the Lender's representative from performing its contractual duties as per contract.

4.1.1 Project Evaluation and Analysis

It may be prudent here to clarify what evaluation is. Evaluation is basically a process which:

- Supports a specific project, by measuring the extent to which the objectives are achieved, and highlights areas for potential development and improvement,
- Identifies achievements,
- Facilitates and encourages decisions to be taken, including modifications to objectives and the project methodology.
- Make recommendations for further development of the project.

Once it is established that the borrower's estimated costs are in line with typical local costs, the Consultant proceeds to prepare a comprehensive review of the project plans and specifications to assure the lender that the design is in compliance with good engineering practice. A detailed written report is prepared and submitted to the Lender describing important aspects of the project and to include comments on the following:

- Completeness of plans, specifications and related information and their conformance with all applicable building codes and zoning ordinances.
- If LEED or other green certification is being sought, confirm that documents meet all requirements.
- If International Green Construction Code (IgCC) is applicable, ensure all documents are in conformance with these codes.
- Design of architectural, structural, HVAC, electrical, plumbing, fire-protection systems, elevators, site improvements and other relevant information.
- Borrower's itemized trades cost breakdown.
- Soil borings contents, load tests, engineering reports, and environmental impact studies
- Areas of potential complications, which would become a problem to the Lender.

- Architectural and engineering agreements, material and construction contracts for completeness, function, responsibility, and costs.
- Conformity of materials (eco-friendly when possible) specified with project's overall quality objectives.
- Conformity of project scope and design as outlined in the plans and specifications and the project description as set forth in the loan agreement.
- Attaining borrower's projected date of construction commencement and date of final completion.

It is really important to ensure that the above are accomplished, for as Paul Eldrenkamp, founding partner of The DEAP Energy Group, says, "One of the most striking things about our industry is just how many chances there are to make mistakes. For every opportunity you have to get something right, it seems, there's a 1000 chances to get it wrong."



4.2 FRONT-END PROJECT ANALYSIS

Prior to construction, the Lender's representative will often be requested to perform a one-time front-end analysis which will be summarized in a separate Project Analysis Report (PAR), dated and signed by the Consultant(s) performing the front-end analysis. The PAR will include a review the borrower's plans and specifications to evaluate the completeness of these documents. Moreover, construction lenders will frequently request an analysis of the contractor's estimated construction costs to determine if available funds are sufficient to complete the proposed project, and opine on the feasibility of the project. During this process, all other relevant contract documents, such as Environmental Reports, Geotechnical Reports, the construction contract, permits, etc., are also reviewed. If questions or problems arise, the Lender normally contacts the borrower, contractor, or their representative for prompt clarification, in order to accommodate the loan closing time frame. The original project front-end analysis report is typically delivered to the Lender within roughly three weeks following receipt of the required documents and notice to proceed from the Lender. It should normally include:

- A Construction Documents Review
- A Construction Costs Review
- A Preclosing Construction Progress Inspection
- A Preclosing Site Inspection
- Attendance at the Lender's Preconstruction Meeting
- Team selection and preparing a preproject plan

4.2.1 Construction Documents Review

Two complete, half size, sealed, and signed sets of the plans and specs itemized below are forwarded to the Consultant. Plans are to be an exact duplicate set of those submitted to the Department of Buildings and the Lender. A list of the drawings from the architect's office should accompany the drawings forwarded to the Lender's representative, which references each drawing as to the date of preparation and last revision date. If one of the sets is not stamped "Approved" by the Building Department, a letter should then accompany the plans from the architect's office confirming that the documents are an exact duplicate set of those approved by the Building Department. Copies of all revised drawings (with revisions indicated) and specification addenda should be forwarded as issued. One (1) complete set of existing building plans and specifications (as-builts if available) should also be forwarded. The documents should include the following:

- Specifications/Project Manual
- Site Plans and Off-Site Plans, if any
- Landscape Plans
- Zoning Sheets
- Architectural and Interior Design
- Structural Plans and Calculations
- HVAC
- Electrical
- Plumbing
- Fire Protection
- Parking structure plans and specifications.

The exchange of information required by the Construction Consultant to begin the loan monitoring includes the following:

Letter of Agreement: One of the first issues to be resolved is a letter of agreement between the Construction Consultant and the Lender spelling out the extent of services to be performed, fee rate, and payment method.

The Owner's Agreements with Contractors: The Construction Consultant should be familiar with all the parties involved in the project. It should also be noted that there may be other work proceeding in the project that differs from the Owner/Contractor's Agreement listed with the lender; these should be taken into account so that the lender may understand potential liabilities on the project. The American Institute of Architects (AIA) Document A101 standard form of agreement between Owner and Contractor is widely used where the basis of payment is a stipulated sum (fixed price).

Plans and Specifications: The Construction Consultant should review the architect or designer's plans and specifications to confirm that the lender's intended understanding of value will be translated to the contractor. At the site, the Construction Consultant will confirm that materials specified for the project are in fact used and any modifications are appropriately documented for the protection of the parties.

Survey: The instrument survey should be completed at the appropriate time and submitted to the Construction Consultant for verification of compliance with all zoning requirements.

Title Report/Deed: The Construction Consultant should review the title report and take note of any special restrictions or conditions that may be placed on the property and confirm that the project conforms to these restrictions.

Contractor's Schedule of Costs: Development of an accurately broken down Contractor's Schedule of Costs into significantly small items will avoid overpayment to the contractor and is one of the most important tasks of the Construction Consultant. This will also be the data used to determine the value of draws against completed work in place to date. This schedule is intended to work hand-in-hand with the construction schedule.

Confirmation of Utilities: The Construction Consultant should confirm prior to the release of the financial commitment letter that specified utilities are available to the property or that the contractor has made alternative arrangements.

Building Permit: Before building construction is permitted to commence, verification that a proper building permit was issued should be confirmed. Sometimes partial building permits are issued which can present a great deal of difficulty for the lender, and therefore, it is important to fully investigate the reasons for partial permit. Changes or conditions requested by the municipality should also be noted.

Release from Special Entities: Releases from special entities should be confirmed before construction begins. This might include special approvals from design review boards, curb cut permits, etc.



4.3 REQUISITION FORMAT

Many lenders have developed their own requisition form or format that they would prefer for the Borrower to use. The Lender should be

consulted to see whether such a form exists. Failing that, the most widely used application for payment standards forms are:

- **AIA Forms—G702 Application and Certificate for Payment,**
- **ConsensusDOCS 291: Application for Payment (GMP)—** Facilitates the calculation and documentation of progress payments where the basis of payment is a guaranteed maximum price.
- **EJCDC (Engineers Joint Contract Documents Committee) contract documents:** This is another alternative to the AIA contracts.

If the AIA documents are to be used, the requisition should be put together with the line items organized in the AIA G702 format and with as many line items as reasonably possible. Where line items contain more than one trade or work scope they should be broken down into the individual subcontracts that will be awarded for same. All of the subcontractual costs are to be subtotaled prior to adding general conditions, a builder's or developer's fee, and the contingency line items. The AIA contractor form G702 Application and Certificate for Payment is a convenient method with which the contractor can apply for payment and the architect can certify payment is due.

With respect to AIA document G702 Application and Certificate for Payment, the AIA requires the contractor to show:

- The status of the contract sum to date, including the total dollar amount of the work completed and stored to date;
- The amount of the retainage (if any);
- The total previous payments (if any);
- A summary of the change orders (if any);
- The amount of the payment currently being requested.

AIA Document G702 serves as both the contractor's application and the architect's certification. Using it can expedite payment and reduce the possibility of error. If the application is correctly completed and acceptable to the architect, the architect's signature certifies/ confirms to the owner that a payment in the amount indicated is due to the contractor. Also, this form allows the architect to certify an amount other than the amount applied for, with the architect providing a satisfactory explanation. G703 Continuation Sheet for G702 breaks the contract sum into portions of the work in accordance with a schedule of values required by the general conditions.

In reviewing of the Payment Requisition, the Project Architect/ Administrator (the "Administrator") is authorized by the Lender only to approve funds commensurate with the value of work-in-place at the time of the site visit. The Administrator will not approve projected or anticipated

values of completion. Fig. 4.1 is a sample letter addressed to the Lender Bank confirming the procedure and monthly document requirements to allow disbursement of funds.

Prior to the site visit, the requisition columns for related work completed during the period covered, and the columns relating to the total value of work completed to date, should be completely penciled-in. The requisition should also include the Architect-of-Record's sign-off. And to support the value of work completed to date for the various line items,

Name _____ Date _____
 Title _____
 Name of Bank _____
 Street Address _____
 City, State Zip _____
 () - (tel) _____
 () - (fax) _____
 Email _____

Re: ABC Project No. _____
 Loan Disbursement Requirements
 Name of Borrower _____
 Name of Project _____

Dear _____ :

Attached is a copy of ABC's "Monthly Documentation Requirements".

Please review, revise, and fill in the blanks so as to comply with Name of Bank's disbursement procedure requirements/policies and this project's construction loan agreement (CLA). Your attention is specifically directed to Item Nos. 4, 8, 9, 10, 11, 12, 13, and 14.

Please fax an edited copy of this schedule to this office and ABC will then revise the attached schedule and send same to the borrower as per your requirements.

Please do not hesitate to call me should you have any questions at ext. _____.

Sincerely,

ABC GREEN INTERNATIONAL, INC.

Name _____
 Project Manager _____

 enclosure

SK:\PMO\CHECKLST\MONTHLY.LTR

Figure 4.1 A sample letter to the Lender is shown to approve and comment upon the monthly document requirements from the project owner (borrower) to facilitate normal disbursement procedure requirements.

MONTHLY DOCUMENTATION REQUIREMENTS
Construction Loan Monitoring Services

In accordance with the Construction Loan Agreement (CLA), the following items are to be provided by the borrower to ABC Green International prior to each monthly advance:

1. Subcontracts & Purchase Orders	All executed subcontracts and purchase orders greater than \$ _____ or for which the aggregate cost of services, work, or materials will exceed \$ _____.
2. Payment & Performance Bonds	Copies of executed bonds are to be provided from the GC or CM and all subcontractors as required by the contract and loan agreements prior to releasing payment for same.
3. Trade Payment Breakdowns ("TPB")	Fully detailed TPBs are to be submitted for every subcontract and purchase order. All TPBs are to be approved by the borrower or the CM, should a CM be used.
4. Revised Budgets	Any revised direct cost construction budgets or cost-to-complete budgets.
5. Monthly Job Cost Report	This schedule will typically indicate: the original budget; buyout status to date by showing actual subcontract amounts; scope changes prior to subcontract; approved, pending, and anticipated change orders; total value of work in place; balance to completion, and the total anticipated project cost. This spread sheet report is to be prepared by the borrower if a GC is used or by the CM and then approved by the borrower.
6. Payment Requisition	A direct cost payment requisition prepared in the format of AIA Document No. G702 with the following modifications: line item amounts are to reflect actual subcontract amounts; work completed is to be on a cost incurred basis - not on a percentage of completion; and stored materials are not to be included in the value of work completed, but tracked on a separate Stored Material Inventory Control Schedule. Retainage is to be withheld as per the CLA requirements. The requisition is to be signed-off by the designer-of-record.

Figure 4.1 Cont'd

the Borrower (project owner) submits the subcontractor's schedule of values, prepared by all of the subcontractors for the Consultant's review and approval. These schedules should be previously reviewed and approved by the Borrower and his CM or GC to guard against front-loading prior to the Consultant receiving them. Lump sum amount subcontractor invoices while necessary, on their own are not deemed adequate to establish value of work completed and should be corroborated.

The Consultant should be satisfied that the amount requested accurately reflects the value of work-in-place, and also that the line item has a sufficient

MONTHLY PROJECT STATUS REQUIREMENTS - continued

7. Partial & Full Waivers of Lien	Partial waivers are to accompany each subcontractor requisition for subcontracts greater than \$_____. Conditional final waivers are to be obtained from each subcontractor and the GC or CM prior to final payment being released.
8. Change Orders	Copies of all change orders complete with sign-off by the architect or engineer-of-record should the change order result in a deviation from the lender's set of approved contract drawings and/or specifications.
9. Change Order Schedule	A separate schedule identifying each change order, the subcontractor, the add or deduct amount, the date received, and whether it has been approved or if it is pending.
10. Stored Material Documentation	<p>Not all lenders allow funding of stored materials. If funding for stored materials is permitted, review the CLA requirements for the caps on a single stored item and the aggregate dollar amount of materials to be funded at any given time. Consult the CLA to determine if corresponding proportional amounts of general conditions and developer's fee are permitted to be released for stored materials prior to the materials actually being installed. Also, determine whether retainage is to be withheld for stored materials. Typical documentation required by the lender in order to receive funding consists of:</p> <ul style="list-style-type: none"> • Stored Material Inventory Control Schedule • Subcontracts • Bills of sale • UCC statements • Insurance certificates • Inspection and acceptance certificates
11. General Conditions	General conditions are to be funded on a cost-incurred basis, but the amount disbursed is not to exceed the direct cost percentage of completion. Check to determine whether the CLA permits monthly equal payment funding.
12. Retainage	Check to determine whether the CLA requires retainage on such items as stored materials, general conditions, the CM fee, and the developer's fee.

Figure 4.1 Cont'd

balance available to effect completion of the outstanding work. And unless otherwise directed by the Lender, monies and percentages of completion approved will be based solely upon the actual subcontract amount, and not the line item's original budgeted amount. Should there be a buyout savings, this "savings" is to be allocated to the requisition's contingency budget. Ideally, the Consultant/Administrator typically tries to reach agreement on the value of work-in-place prior to leaving the job site.

MONTHLY PROJECT STATUS REQUIREMENTS - continued

13. Shop Drawing Documentation	Not all lenders fund for shop drawings; check the CLA. If funding is permitted, have the designer-of-record provide a statement that the shop drawings prepared have been approved. An approved shop drawing invoice complete with back-up documentation for the time expended is also usually required.
14. Trade Mobilization Cost	Not all lenders fund for trade mobilization costs; check the CLA. Some lenders will fund half the up-front mobilization costs leaving the half to be paid upon completion of "demobilization" costs. Cost breakdown documentation for the basis of this invoice is usually required.
15. Designer-of-Record's Field Observation Reports	On a weekly basis, all Field Observation Reports are to be forwarded to ABC. Please have ABC placed on the routing list.
16. Monthly Compliance Certification	Certification by the appropriate designers-of-record that the work completed during the payment requisition period was performed in compliance with the lender's set of approved drawings and specifications.
17. As-Built Foundation Plan	Upon completion of the foundation, an as-built foundation survey certified to the bank is to be prepared by a licensed surveyor and accompanied by a statement from the designer-of-record that the foundation was constructed within the required setbacks and to the correct elevations. With respect to a pile foundation, a certified as-driven pile location plan and certified pile log will be required prior to release of funds in addition to an as-built foundation survey.
18. Construction Schedule	All construction schedule revisions.
19. Testing Reports	Copies of all testing reports. Testing results which deviate from the design requirements should be accompanied with a copy of the designer-of-record's response to same. Please have ABC placed on the routing list.
20. Work Log	A trade-by-trade man-day count synopsis for the payment requisition period.
21. Photos	Copies of prints, if monthly construction progress photos are being taken.
22. Certificates of Occupancy	Whether temporary or permanent, as the space or units are accepted by the local governmental authority.

Figure 4.1 Cont'd

Monthly Job Cost Reports: The borrower should provide a monthly Job Cost Report/Project Status Report (JCR/PSR) or as required by the Lender that will detail such information relating to the project as:

- The actual contract or purchase order costs compared to the original budget's line items
- Total amount of change orders (approved and pending)
- Total estimated project cost

The JCR has considerable value as it provides timely information about the status of the project budget and allows the Administrator to take whatever action may be necessary to bring the project into compliance with the original budget. The JCR will essentially provide for each item, the quantity and/or percentage completed to date, the cost of the item to date, the estimated cost remaining to complete the item, and the total cost estimate for the item at completion. An estimate cost for the entire project is arrived at by calculating the sum totals of these costs.



4.4 SITE VISITS AND OBSERVATIONS

Normally construction field observations consist of visits to the site at intervals appropriate to the stage of construction or as otherwise agreed in writing. This is necessary to monitor the progress and quality of the work and to determine in general if the work is proceeding in accordance with the Contract Documents, and preparing related reports and communications. Regular site visits for observations and direct communication with the contractor also help facilitate a smooth building process.

4.4.1 Lender's Preconstruction Meeting

But prior to conducting normal site visits, one of the first and most important steps in the design phase is a design kickoff or orientation meeting. This is usually scheduled by the Project Manager at or about the time that the contract with the Design Professional is executed and approved, depending upon the project. The main attendees at this meeting generally include the main stakeholders and participants with an interest in the project, including the design team, cost estimator, commissioning agent, and owner. The agenda generally includes introduction of personnel involved in the project, discussion of administrative procedures, discussion of project scope, budget and schedule, and a site visit and walk-through. The Design Professional/Project Manager should record attendance and prepare and distribute an agenda and minutes of the design kickoff meeting. The Design Professional should also prepare a project directory of all participants, including name, title, address, e-mail address, phone, and fax.

Following the acceptance of the successful bid and subsequent award of the contract for construction, the Owner, along with the Contractor and Administrator/Consultant shall schedule Preconstruction Meeting preferably at the site (prior to closing of the loan). The purpose of the Preconstruction Meeting is to discuss the specific requirements of the Contract Documents and how they relate to the daily operation of the construction project (Fig. 4.2). Also on the agenda will be a discussion of the lines of authority and communication.

(a)**AGENDA****Germantown Housing Project
Project Kick-off Meeting****ABC Project No. A30115****Date: February, 7, 2015****1. Project Overview**

- a. What is the development plan?

2. Project Team

- a. Who comprises the project team? What is the project extent of involvement?
- b. Table of Organization.

3. Plans & Specifications

- a. Are the base building plans and specifications complete?
- b. Any part of the project being completed on a design/build basis?

4. Construction Period

- a. When is the projected start and completion dates?
- b. Project duration?
- c. Schedule updates and who will prepare them?

5. Project Budget and Contracts

- a. Direct cost budget and what are the components? Is there a detailed direct cost estimate and breakdown; when last updated?
- b. Copies of subcontracts, purchase orders, etc.
- c. What is timetable on Owner/GC/CM Agreement?
- d. Any trade payment breakdowns available?
- e. Any work to be performed with GC's own forces? If so, what are the trades? What percentage of the entire contract amount does such work represent?
- f. What percentage of the direct cost has been secured by subcontract pricing to date?

Figure 4.2 (a) Typical agenda for a preconstruction kick-off meeting. Actual agenda will depend on type of project, project requirements, and circumstances. (b) Example of worker's compensation.

6. Existing Building Condition Survey Reports

- a. Envelope/Structural Report
- b. MEP Systems

7. Permit Status

- a. Are permits issued as a whole or in stages?
- b. Status of documentation review by municipality.
- c. Schedule of necessary permits.

8. Bonds

- a. Will the GC/CM, if any be securing a 100% Performance and Payment Bond for the project?
- b. Will subcontractors be bonded? If so, who?

9. Architect/Engineer Field Inspection Reports and Punch lists

Will architect/engineer field inspections be conducted, at what frequency, and will reports and punch lists be prepared?

10. Quality Assurance Program

What type of program is in place for quality assurance in addition to the municipality required controlled testing?

11. Change Orders

- a. That is the procedure for change order approval?
- b. A separate schedule is requested identifying each change order, the subcontractor, the add or deduct amount or scope change, the date received, and whether it has been approved or is pending review.

Figure 4.2 Cont'd

The Lender in collaboration with the Owner and Design Team shall coordinate and establish the date, time, and place the meeting will be held. The purpose of this meeting is to meet collectively with all parties to the construction project (including the owner's representative, lender's representative, architect, primary engineers, contractor's project manager, and supervisory staff as well as major subcontractors and vendors) and discuss the status of the work, construction documents, and contractual relationships, and the Lender's draw procedures and requirements. Sometimes, certain outside agencies may be called in to attend the initial meeting such as fire marshals and public utility personnel.

(b)**WORKER'S COMPENSATION**

	Limit of Liability
Worker's Compensation	Statutory Benefits
Employer's Liability	\$ 500,000

COMPREHENSIVE GENERAL LIABILITY

(including coverage of Contractual Liability assumed by the Contractor under Indemnity Agreement set forth below and completed operations coverage).

	Limit of Liability
Bodily Injury	\$ 1,000,000 per occurrence
Property Damage	\$ 1,000,000 per occurrence
Professional Liability	\$ 1,000,000 per occurrence or claims made form (coverage shall be maintained for three years following expiration of the assignment).

COMPREHENSIVE AUTOMOBILE LIABILITY

	Limit of Liability
Bodily Injury	\$ 1,000,000 per occurrence
Property Damage	\$ 1,000,000 per occurrence

Of note, it is now common practice to limit liability to the Consultant's fee or a sum of say \$ 50,000, whichever is greater.

Figure 4.2 Cont'd

This meeting usually covers all of the items listed in the General Conditions and Supplemental Conditions of the contract but in greater detail. The preconstruction meeting offers an opportunity for the main participants to be introduced and get to know one another. Also, discussing certain items in advance can alleviate future misunderstandings that might otherwise impair the process. Some of the more common issues to be discussed during the preconstruction meeting include:

- Introduction of personnel and individual roles and accountabilities
- Names of contacts for the bank and the contractor
- Amount of retainage to be withheld
- Number of draws allowed per month

- Contractor shall ensure that competent Superintendent is on site at all times when work is taking place
- Scheduling/Coordination: Construction Duration, Contract dates (Start and Completion dates), Hours of operation
- Mobilization and site logistics (site access and security, temporary utilities, temporary facilities)
- Construction Coordination Issues (requests for Information (RFIs), subcontracts, submittals, shop drawings)
- Schedule Issues (Notice to proceed, work schedule, sequence of work, liquidated damages)
- Payment Issues (application for payment, schedules of value). Clarify how draw request is to be submitted
- Change Orders and additional work
- Completion Procedures (substantial completion, final inspection, final punch-list, final waivers of lien, final payment)
- Clarify method of payment and advances for materials stored on site
- Dispute Issues

4.4.2 Preconstruction Documents

The preconstruction phase of a project is probably just as important as the actual construction phase. During the preconstruction phase, the rules and boundaries of the project are determined and defined, including the overall scope of work. This phase also allows us to identify any potential problems and to create a complete building plan. By having a complete plan, the project's estimated cost can be determined as well as its schedule for completion, permitting, and other factors. The most important goal of comprehensive drawings is to make sure that the project is completed on time and within budget.

Thus, following the preconstruction meeting and prior to commencement of construction, the contract administrator or owner and/or architect will ensure that certain documents have been executed between the owner and the contractor, including but not limited to the following:

- “Notice of Commencement” from Owner
- “Notice to Proceed” from the Owner
- Property survey from the Owner
- All required Permits, Licenses, and Governmental Approvals
- Insurance coverage to be carried by the contractor and all subcontractors
- Bonds—contractor's copies of its performance and payment bonds in addition to proof that subcontractors have furnished surety bonds as required by the Contract Documents

Notice of Commencement: In order to protect the owner and mandate notice to the owner of potential lien claimants, the Notice of Commencement must be prepared and filed before the project commences. It is a legal document prepared by the owner's attorney or financial lending institution and recorded with the Clerk of the County Court. The owner is required to have it recorded and a copy must be posted by the owner at the project site. The owner, administrator and/or architect should also obtain a photocopy of the Notice of Commencement for his project files. Financing institutions will likewise require the filing of a Notice of Commencement as a provision of the loan agreement.

A Notice of Commencement is a recorded statement executed by the owner, and is considered to be one of the most important documents on a construction project and is the first document filed for the lien process, yet its importance is frequently overlooked by contractors. The Notice of Commencement identifies the name and address of the owner and requires that all persons that provide labor and materials to send a Notice to Owner. Recording the Notice of Commencement is necessary and by doing so the owner can require the general contractor to supply releases of lien from all persons that have served a "Notice to Owner." Construction must commence within 90 (90) days from the date that the Notice of Commencement had been recorded. The Notice of Commencement is effective for one year after it is recorded unless otherwise provided in the Notice. Failure to pay attention to the Notice of Commencement can have serious consequences and adversely affect a contractor's ability to recover for the work performed on a project. The three main issues that contractors need to pay attention to regarding their project's Notice of Commencement are:

- When does the Notice of Commencement expire?
- Was the bond attached to it?
- When was the Notice of Commencement recorded?

By posting the Notice of Commencement at the project site and on public record the name of the owner, the contractor, and surety are provided, so that anyone wishing to file Notice to owner may do so. Owners can protect their property from liens by requesting the general contractor to provide proof that all laborers, material men, and suppliers have been fully paid. Requiring the general contractor to furnish partial and final releases of lien to the owner will prevent those persons from placing liens on the owner's property due to nonpayment by the general contractor. Any work executed at the project site prior to the Notice of Commencement is not covered by the lien laws, and while the Notice of Commencement is the

**(a) Texas Department of Housing and Community Affairs
Colonia Self Help Center Program**



Pre-Construction Conference Report and Notice to Proceed			
County: _____	Contract Number: _____		
Homeowner Name(s): _____	Homeowner Address: _____		
Building Contractor Name: _____	Building Contractor Address: _____	Contract Amount: _____	
<p>Statement of Homeowner: I/We, the undersigned, [hereinafter referred to as Homeowner], participated at _____, on this date, _____, in a pre-construction conference prior to signing a contract for the rehabilitation, reconstruction, or new construction of my/our property. Homeowner(s) acknowledge that I/we understand the terms of the contract, the explanation of the work to be performed by Building Contractor, the roles of the county and Colonia Self Help Center, and our responsibilities during the construction phase. Homeowner's questions have been adequately answered and I/we are aware that assistance will be provided by the county as requested.</p>			
_____ Signature of Homeowner	_____ Date	_____ Signature of Homeowner	_____ Date
<p>Statement of Building Contractor I, the undersigned, [hereinafter referred to as Building Contractor], hereby certify that I participated in a pre-construction conference with the above-referenced Homeowner and the Colonia Self Help Center's authorized representative at the above-referenced location on this date. Building Contractor understands the procedures to be followed for work write-ups, change orders, work performance, construction, requests for inspections, and requests for payments. Building Contractor understands and hereby certifies that, upon completion, the work performed will meet or exceed all minimum construction standards, specifications, regulations, and codes as required by the Colonia Self Help Center Program and state law. Building Contractor hereby certifies that the work performed will be warranted for a period of one year from date of project completion.</p>			
_____ Signature of Building Contractor		_____ Date	
<p>Statement of Colonia Self Help Center Representative I, the undersigned, hereby certify that I participated in a pre-construction conference with the above-referenced Homeowner and Building Contractor at the above-referenced location on this date.</p>			
_____ Signature of Colonia SHC Authorized Representative		_____ Date	
<p>Notice to Proceed</p> <p><input type="checkbox"/> I/We, the undersigned, hereby authorize the above-referenced Building Contractor to commence work on the property located at _____ within _____ days of the execution of this document. The property will be available to Building Contractor to perform the specified work between _____ a.m. and _____ p.m., seven days a week, unless otherwise specified by Homeowner. If Building Contractor does not commence work within the specified time, the Homeowner may, upon proper notification, consider Building Contractor to be in default.</p> <p><input type="checkbox"/> I elect to withhold authorization to proceed until a later date at which time a separate Notice to Proceed will be issued.</p>			
_____ Signature of Homeowner	_____ Date	_____ Signature of Homeowner	_____ Date

Figure 4.3 (a) Typical notice to proceed document issued by the Texas Department of Housing and Community Affairs. (b) A homeowner's notice to proceed with rehabilitation construction. This is one of the most important documents that the contractor should be aware of and failure to do so can have serious adverse consequences and significantly impact a contractor's ability to recover for work performed on a project.

(b) SAMPLE NOTICE TO PROCEED

TO: Contractor

FROM: Homeowner Name(s)

SUBJECT: Notice to Proceed with Rehabilitation Construction

Name of Homeowner(s), as owner(s) of the property located at Address award the rehabilitation contract to Name of Contractor, on Date. Contractor is hereby notified to commence work set forth in the contract on or before Date.

All work is to be done in accordance with program specifications, conditions provided in the contract, and the work write-up that has my (our) initials on each page and signature on last page.

The project must be fully complete within Number consecutive calendar days after Date. The date of completion of all work is, therefore Date.

If the contractor does not commence work within the specified time, I (We) may upon proper notification, consider the rehabilitation contract to be in default.

_____ Signature of Homeowner	_____ Date
_____ Signature of Homeowner	_____ Date
_____ Signature of Contractor	_____ Date
_____ Signature of Grantee	_____ Date

Figure 4.3 Cont'd

owner's responsibility, the owner, administrator, and/or Architect should so advise the owner of both the need and benefits of such a document. The Owner/Contractor Agreement should stipulate that work is not to commence until the Notice of Commencement has been issued. Two typical examples of a Notice to Proceed issued by the State of Texas and a homeowner are shown in [Fig. 4.3a](#) and [b](#).

Notice to Proceed: The notice to proceed is the document that certifies the contractor of the acceptance of its proposal and officially directs the contractor to commence work within a specified time such as 10 business days. Work to be executed under the owner/contractor agreement generally begins on the date specified in the notice to proceed document, and as

articulated in the general conditions of the contract for construction. The notice to proceed also triggers the project commencement date by establishing the reference date from which the project duration is measured; often the contract will stipulate that work is to be completed within a stated number of calendar days after the contractor receives its notice to proceed. At this point, it is considered good practice for the owner to notify unsuccessful tenderers. The notice to proceed implies that the site is free of encumbrances and therefore is available for the contractor's use. However, if there are unresolved issues, then the owner may issue a letter of intent stating that it intends to contract with the contractors upon resolving any outstanding issues.

The owner and/or architect shall recognize that the "Date of Commencement" is the official date for the start of the construction project and is specifically identified in the Notice to Proceed. However, it would often be difficult for the contractor to start work on the very date the notice to proceed is issued unless the contractor has had prior knowledge of the notice to proceed and adequate time to mobilize the firm's resources, project team, and equipment to the site.

4.4.3 Walk the Site/Project

Upon awarding the project and the contractor commences work on site, the project Consultant or Administrator representing the Lender shall periodically visit the site and walk the entire project to observe the construction progress in conjunction with and for the purpose of reviewing each monthly construction draw application for payment throughout the entire duration of the construction project, unless notified otherwise by the Lender. At the time of the regular monthly site visit the Consultant/Administrator shall conduct a separate walk-thru of the project, to determine the percentage of completion and subsequent to review of the draw application for payment. The purpose of this walk-thru will be to observe and determine, in detail, the quality of workmanship and materials, and conformance to the contract documents.

The consultant is required to conduct periodic site observation reviews during the construction process. These regular site visits enable the consultant to ascertain whether construction is progressing satisfactorily and in substantial compliance with plans, specifications, and applicable building codes. The consultant's role includes commenting on the quality of workmanship, materials, stored materials, scheduling, and possible issues. Construction lenders require verification by the consultant that requests for payment of construction funds are accurate and suitable for disbursement.

Any issues that need addressing or questions needing answers are discussed with on-site personnel as applicable and if the issues are significant, they are reported to the lender. They are also promptly submitted to the borrower for explanation or corrections.

The Consultant will vary the inspections schedule to meet the Lender's needs, e.g., from once a week to once a month, as often as needed, to verify satisfactory performance and progress at time of each requisition for payment from the Borrower. A written report of each on-site inspection is submitted to the Lender within an agreed time-frame, and which should typically include:

- A detailed description of the construction progress achieved since the previous inspection of the project.
- Observation of quality of work in place and whether construction is proceeding in general accordance with the approved plans and specifications.
- A calculated percentage of work in place, overall and by trade.
- Comments on whether the work is proceeding according to schedule and an estimated date as to when the project will be completed.
- Annotated photographs of the project (20–40 photographs) showing progress of construction, problem areas, and unacceptable work or conditions.
- Unfavorable discrepancies, if any, with recommendations of corrective action.

Reports are presented in a form designed to convey accuracy and provide the Lender with a feeling of actually “walking through” the site with the Consultant.

4.4.4 Photo Documentation

Prior to the advent of digital photography, site progress photos were typically printed to $3\frac{1}{2} \times 5$ in. formats for inserting into standard reports. However, today digital cameras have transformed the industry and are now almost exclusively used to document construction progress (although video is also sometimes used). The objective of photographing a project whether an existing building or one under construction is to document representative conditions and use reasonable efforts to document typical conditions present including material or physical deficiencies, if any. There are several formats that can be used, but Consultants most often use one of two templates depending on the Lender's needs. These consist either of two photos per page or six photos per page (Fig. 4.4). Captions explaining each photo are helpful to more clearly explain and convey relevant information

(a)

XYZ Office Park
May 26, 2016



5. View showing the Elevator Lobby on the 5th floor of XYZ Office Park that was previously leased by Doe International. Base Building and Tenant Improvements are substantially complete.



6. Interior view showing vacant space on the 5th floor of XYZ Office Park. Base Building is complete. Letter of Intent reportedly in hand from Global Computer Solutions.

 ABC Green International, Inc.

XYZ Project No. A19421

Figure 4.4 (a, b) Typical templates using two and six photographs per page. Photographs are almost always required for reports and other documentation.

(b)

ABC Highrise Apartments



1 Interior – View of work in progress on Unit 302 on the third floor of the ABC Apartments. About 230 units are now complete and 12 others are in progress. Unit is scheduled to be completed by end of January 8, 2012



2 Interior – View showing work in progress on the upgrading of the Bathroom plumbing in Unit 1104 on the eleventh floor. Unit is scheduled to be completed by January 10, 2012



3 Interior – View of Kitchen of Unit 1120 on the eleventh floor of the ABC Apartments. Apartment unit is complete and ready for hand over.



4 Interior – View of Living room in Unit No. 1120 on the eleventh floor of the ABC Apartments, showing status of renovation. Work on unit is complete.



5 Interior – View of new Office Workspace on the first floor which is scheduled to be completed by third week of January 10, 2012



6 Interior – View of newly created Handicap unit (No. 225) on the second floor of the ABC Apartments. View of Kitchen area. Unit is temporarily being used as an office

Figure 4.4 Cont'd

regarding the project. It is also sometimes helpful to add an arrow pointing to the particular item of interest in the photograph for maximum effect.

Photography is an extremely effective way of recording factual observations. Photographs can provide information detail that would be difficult to convey using other mediums. Later, notes or captions can be added to the photographs for further clarification. If dealing with an existing building or project under construction, the first step is to take photographs of the project from various angles with particular attention to detail of work, e.g., that is defective, etc. This is done prior to writing the report, as it will refresh your memory as to what was taking place during your site visit and it will alert you to specific items that may require the attention of both the Lender and contractor. The various photos can also be referenced within the “Field Observations” section of the report.

Photographs should be sorted and placed in a logical manner within a photo template with captions to reflect the various aspects of the project that are to be portrayed and then included in the report. For most assignments (depending on size, complexity, condition of facility, and at what stage of construction the building is at), the number of photographs will typically range between 20 and 40 photos. The aspects that should typically be photographed of a project depend largely on the type of project but would normally include some or all of the following aspects:

1. Site (from various angles)
2. Exterior/Building Envelope
3. Roof
4. Interior
5. Structural
6. Mechanicals
7. Electrical
8. Plumbing
9. Fire Protection/Life Safety
10. Garages/Carports
11. Elevators (and lobbies)
12. Amenities
13. ADA
14. Detail photographs should follow
15. Stored Materials (How will advances for materials stored on-site be treated?)

Once the photographs have been organized in a logical sequence, prepare the photo sheets and number each photo with appropriate captions.

On the photo sheets, the various components of the project should be identified. For multistory buildings, each photograph should identify the floor or elevation shown. The object is to convey to the Lender the project's progress and any other relevant information pertaining to the project. Comments placed on the photographs should convey a thorough familiarity with the project and highlight information not clearly shown in the photographs.



4.5 LOAN DISBURSEMENTS—DRAW APPLICATION REVIEWS

A Lender's construction risk management practices are designed to look out for the interests of both the Lender, as well as the borrower. Both borrower and bank interests lie along the same path toward successful completion of construction. There are numerous things that could go wrong during the construction phase of the loan, and many issues that need clarification prior to commencement of the project such as:

- Ensure that the loan documents match the approval
- Ensure that the proposed budget has sufficient funds to complete the project
- Check that there is adequate equity in the project
- Ensure that the draw requests balance
- The proposed budget must pass the plan and cost review

4.5.1 Value of Work in Place

During the scheduled site meetings the Borrower's payment requisitions are reviewed and evaluated by the Consultant/Administrator usually on the basis of accurate quantities of work in place and approved. Following the on-site inspection the results are compared with the Borrower's requisition for funding for work in place up to the time of the inspection. Any discrepancies should be promptly resolved, preferably prior to submission of the requisition to the lending institution. The main purpose of closely monitoring the flow of construction loan dollars is to ensure that, at any given time during the life of the loan, that sufficient funds remain in the undisturbed portion of the loan to complete the project. Any delays in the work should be promptly reported to the Borrower and Lender.

For the purpose of calculating the total value of work in place, the contractor has to break down the Schedule of Values into items or quantities of

work which can readily be evaluated by the Administrator when estimating the work in place. This breakdown is separate from the Schedule of Values and does not replace it. The main purpose of the breakdown is to prevent potential disagreements between the contractor and the administrator when evaluating the quantities of work completed. But the value of work in place should be developed prior to writing the monthly report. This is because developing a number for work in place will exemplify where the emphasis has to be placed when writing the body of the report and the summary. By knowing the total value of work in place and the amount approved for the period covered, the Administrator will be alerted as to whether the pace of the project is slowing down, speeding up, or whether a particular line item is heading for a cost overrun, and whether potential challenges can be expected down the road, etc.

The contractor can then proceed to prepare a certified copy of the Application for Payment in the format outlined in the contract documents. The Administrator is given a copy of the Application for Payment and verifies that it is correct as per the site review meeting. The contractor shall bring to the review meeting all materials required to properly evaluate the Application for Payment, including stored material invoices, Release of Liens, etc. The administrator, owner and the contractor assess the project's current status along with the contractor's application for payment and agree upon the amount due the contractor as outlined in the contract documents.

Should the Administrator and the contractor not agree on an appropriate amount to be disbursed as per the Application for Payment, the contractor may then prepare and submit an Application for Payment that he/she considers to be appropriate and in line with the work in place. The Owner and/or Architect will then in consultation with the Administrator, recommend to the Owner the amount that he/she feels should be certified for payment. The certified value of work-in-place is based essentially upon the latest site visit and the latest contractor's application for payment. In [Fig. 4.5](#) we see an example of how the certified current value of work-in-place is calculated and which is typically included in the PSR that is sent to the Lender and other stakeholders.

4.5.2 Stored Materials Funding

The Lender has the final say on whether or not stored materials will be funded, and if so, how? In many cases, lenders have indicated their willingness to negotiate this item. However, the Lender must exercise great care and ensure that the funding procedures for stored material comply with

Certified Value of Work-in-Place

Based upon our previous site visit, the GC's Application for Payment No. (*Exhibit "B"*), ABC has determined the current value of work-in-place to be as follows:

Original Direct Cost Budget	\$ 156,286,487	
Adjustments as Approved by BA	+ 0	
Adjusted Direct Cost Budget	\$ 156,286,487	(1)
Total Value of Work Completed To-Date	\$ 43,429,128	
Stored Materials	+ 0	
Subtotal Work Completed and Stored	43,429,128	(2)
Less Retainage	- 2,594,341	
Total Completed Less Retainage	\$ 40,834,787	
Less Previous ABC Certification	- 15,376,052	(3)
Current Certification	\$ 25,458,735	
Cost to-Complete BLA Adjusted Direct Cost Budget, Including Retainage	\$ 115,451,700	
Cost-to-Complete Based upon ABC's Recommended budget of \$165,000,000	\$ 124,165,213	
(1) Based upon Borrower's Direct Cost Budget as follows:		
Off-Site Work	\$ 300,000	
On-Site Work	23,861,912	
Shell/Common Area Construction	59,694,900	
Speciality Tenant Construction	6,732,600	
Speciality Tenant Allowances	11,290,100	
Anchor Tenant Construction	14,640,164	
Anchor Tenant Allowances	+ 39,766,811	
Total Direct Cost Budget	\$ 156,286,487	
(2) Work Completed and Stored To-Date as Follows:		
Off-Site Work	\$ 0	
On-Site Work	25,000,000	
Shell/Common Area Construction	13,515,987	
Speciality Tenant Construction	66,097	
Speciality Tenant Allowances	442,493	
Anchor Tenant Construction	737,775	
Anchor Tenant Allowances	+ 3,666,775	
Total Work Completed To-Date	\$ 43,429,128	
(3) Includes amounts not certified by ABC		

Figure 4.5 Example of how the current value of work in place is calculated.

the Building Loan Agreement (BLA) requirements. So unless specifically authorized by the Lender, the Consultant/Administrator has no contractual authority to approve stored materials. This should be clarified in the general conditions or supplemental conditions. If funding for stored materials is requested, the Consultant/Administrator will note and report to the Lender how the materials are protected from theft, the elements, and vandalism.

The Consultant/Administrator should inspect the insurance certificates for the same to ensure that the Lender is named as a co-insured. Likewise, the Consultant should inspect the invoice, bill-of-sale, a Uniform Commercial Code statement or a contract verifying the cost of the materials in question.

Some of the challenges that stored material funding face are because many lending institutions absolutely prohibit payment for materials until they are physically installed into the improvement. The Lender's main concern is due to increased exposure in the event of a failure by the general contractor or borrower, since recovery of these materials or their cost has traditionally been difficult, if not impossible. Faced with these problems, the lending institutions have often modified their approach to "materials only" payments so that if materials are suitably stored at a bonded warehouse off site payments may sometimes be made. The bottom line is whether payment is to be made for stored materials, and this hinges on the policies of the Lender. It is important to state the conditions for stored material funding in the contract documents. The Borrower would be well advised to reach agreement on the policy toward such advances early in the discussions with the Lender, preferably prior to closing the loan. Stored materials should be tracked on a separate stored material inventory schedule provided by the Lender. It is strongly recommended that the Consultant/Administrator review the BLA regarding the Lender's policy of funding for stored materials because funding may be reserved as a Lender's business decision. If the Lender does decide to proceed with funding the stored materials, a proportionate amount of the general condition or fee monies may be retained.

4.5.3 Changing Orders

Although we often may not be able to escape them, we can try to minimize the hassle and anxiety they can cause by employing the correct procedures. Change orders are in fact changes to the contract (a legal document) and are themselves legal documents. Once a change order is executed, it becomes part of the contract, and cannot be reversed. The only way to make further modification to a contract is to process another change order. The owner is required to provide a schedule and copies of all approved change orders as well as a schedule of pending change orders. Change orders should not be approved unless they have been previously approved by the owner, and there are sufficient funds within the contingency budget to absorb them. After the Owner completes the review of the Proposal Request and approval for the Change Order is obtained, the Administrator shall prepare a Change

CHANGE ORDER

AIA DOCUMENT G701

- Distribution to:
- OWNER
 - ARCHITECT
 - CONTRACTOR
 - FIELD
 - OTHER

PROJECT:
(name, address)

CHANGE ORDER NUMBER:

INITIATION DATE:

TO (Contractor):

ARCHITECT'S PROJECT NO:

CONTRACT FOR:

CONTRACT DATE:

You are directed to make the following changes in this Contract:

Not valid until signed by both the Owner and Architect.
Signature of the Contractor indicates his agreement herewith, including any adjustment in the Contract Sum or Contract Time.

The original (Contract Sum) (Guaranteed Maximum Cost) was \$.
 Net change by previously authorized Change Orders \$.
 The (Contract Sum) (Guaranteed Maximum Cost) prior to this Change Order was \$.
 The (Contract Sum) (Guaranteed Maximum Cost) will be (increased) (decreased) (unchanged)
 by this Change Order..... \$.
 The new (Contract Sum) (Guaranteed Maximum Cost) including this Change Order will be \$.
 The Contract Time will be (increased) (decreased) (unchanged) by () Days
 The Date of Substantial Completion as of the date of this Change Order therefore is

_____ ARCHITECT	_____ CONTRACTOR	_____ OWNER
_____ Address	_____ Address	_____ Address
_____ By	_____ By	_____ By
_____ Date	_____ Date	_____ Date

sk projects\clm\template\changeorder.doc

Figure 4.6 Example of typical change order template.

Order, as outlined in the Contract Documents, utilizing AIA Document G701 or its equivalent. The Change Order will be produced in (3) three copies and forwarded to the Contractor for signature. The Contractor's signature on the Change Order request acknowledges that the work will be completed as described in the Change Order for the stated amount (Fig. 4.6). Any additional time, if requested, for the Change Order work will be

incorporated into the Change Order. Failure by the Contractor to request additional time for the Change Order work will prohibit the Contractor from doing so at a later date. The need for contract changes may be the result of many causes. Among the most common are:

- Plan deficiency (errors or omissions)
- Modified/amended design criteria
- Specification conflict or ambiguity
- Extra work or unanticipated need
- Contractor proposed change (material substitution, etc.)
- Settlement of disputes.
- Price adjustments for increased or decreased quantities.

Once the Contractor has signed the Change Order all (3) three copies will be returned to the Consultant/Administrator or the Owner and/or Architect for signature and certification. The Change Order will then be submitted to the Owner for final signature and distribution. The Owner, Administrator, Contractor, and Owner and/or Architect will receive (1) one signed and certified copy of the Change Order for their records. The Change Order will then be added to the next monthly Application for Payment. The Change Order will be recorded in the Project Log Book and a copy of the Change Order included in the Log Book and a copy will also be transmitted to the Central File System.

The BLA should be checked by the project Administrator for the approval requirements of individual and aggregate change orders amount. Once the change order is approved, a Notice to Proceed is issued to the contractor. However, before this can happen, the Administrator/Owner's Representative will issue a written directive to the contractor asking for a Request for Proposal for the change order work within 10 days for the subject work. This will then be followed with a Notice to Proceed or a Notice to Proceed immediately with the work. The Notice to Proceed will specify the manner in which the owner will pay for the work in question. An independent estimate should be done prior to any negotiation with the Contractor. The options available will be stipulated in the Contract Documents and will usually consist of:

1. An accepted estimate (e.g., using bid prices from recent contracts with similar work and quantities)
2. Time and material estimate
3. Unit costs (e.g., using the "Means Cost Estimating Guide")

The RFP should also address subcontractor mark ups, labor rates, and various other requirements regarding change order pricing. The contractor should not commence with the change order work unless the contractor

receives a written Notice to Proceed. The exact wording and format of the Notice to Proceed form will vary depending on the nature of the work and requested pricing method.

Sometimes Owners will prefer to organize Change Order payments to be separate from the Application for Payment. Likewise, the Contractor may request assurance from the owner that adequate funds are available to pay for the Change Order before executing the work. Financing and lending institutions generally stipulate that all Change Orders be processed through their office before executing the work. Contractor's Performance and Payment Bond, and Builder's Risk Insurance need to be adjusted to reflect substantial changes to the Contract Sum. The Contractor is essentially obligated to execute any Change Order authorized by the Owner even if a dispute occurs regarding the actual cost of the Change Order work or its impact on the Project Schedule. These matters can typically be resolved by exercising provisions included in the Contract Documents.

4.5.4 Lender/Owner Retainage

Retainage is the withholding of certain portions of monies due a contractor for work in place or monies withheld from each progress payment earned by a contractor or subcontractor until a construction project is complete. It acts as an incentive to complete the work, and is one of the line items identified on the contractor's application for payment. It has been the subject of considerable discussion over recent years and it is quite apparent that many lending institutions do not have a uniform practice on either the amount of retainage or the manner in which it is collected. It is routinely called for in both private and public construction contracts. On public projects, state laws often require the use of retainage and specify the amount and the conditions for releasing it. Otherwise, retainage is governed by contract.

Most Lenders generally prefer using a conservative approach in which a full 10 percent (10%) is withheld of all items of construction and is kept through the entire construction period. On the other hand, a liberal policy is maintained in which no retainage is withheld on any item. Between the two extremes, a wide variety of practices are prevalent, including holding a retainage on certain items only or reducing the total amount withheld after a certain point in construction has been reached (usually 50 percent (50%) of project completion). Experience and knowledgeable Borrowers try to negotiate the most liberal agreement possible at the outset of the loan program. It is also common practice for the general contractor to impose retainage on their subcontractors as well although most general contractors try where possible to work with their subcontractors to facilitate early payment.

The Owner may make payments which reflect adjustments in the retainage amounts as provided in the Contract Documents upon the contractor achieving successful execution of the Certificate for Substantial Completion. The reduction in retainage shall be made with the exception of amounts which have been determined to reflect the costs for remaining work to be completed and/or work requiring correction. In these cases, the Administrator, upon consultation with the Owner and/or Architect, shall establish a value for remaining work and suggest that the Owner retain three (3) times the value of incomplete work. The minimum amount retained for each unacceptable item should reflect the estimated cost to have an alternative Contractor brought in to complete or correct the item in question. This includes any costs for mobilization and/or equipment required to correct or complete any outstanding construction deficiencies.

4.5.5 General Conditions

Many standard General Conditions have been developed by numerous trade and professional organizations, but perhaps the most widely used general conditions are those published by the AIA, AIA Document A201 2007 form of General Conditions and the ConsensusDOCS 200 form of General Conditions. Of note, ConsensusDocs just released an entirely updated standard IPD agreement and new IPD Joining Agreement (ConsensusDocs 300). One of the advantages of using the AIA standard is that most contractors and architects are familiar with it. However, many state organizations and universities, etc., have their own standard general conditions depending on the project.

The General Conditions set forth the rights and responsibilities of each of the parties such as the owner and contractor in addition to the surety bond provider, the authority and responsibilities of the design professional and the requirements governing the various parties' business and legal relationships and is considered to be one of the most essential documents associated with the construction contract. It is really imperative that the contractor knows exactly what is contained in the general conditions and its implications. If it proves too difficult to read or there is simply not enough time, the project may be put at risk. Some of the general clauses contained in the general conditions that can have a direct affect on the success of a project, if appropriate attention is not paid to them include:

General Provisions: Includes basic definitions for the contract and roles of the various parties, the work, the drawings and specifications and other issues such as change orders, punch lists, etc. In addition, it clarifies the ownership, use, and overall intent of the contract documents.

Owner Responsibilities: Among other things, it outlines the services and information the owner is required to supply depending on the General Conditions format that is used. For example, the Owner shall, at the written request of the Contractor, prior to commencement of the Work and thereafter, furnish to the Contractor reasonable evidence that financial arrangements are in place to fulfill the Owner's obligations under the Contract. Furnishing of such evidence shall be a condition precedent to commencement or continuation of the Work. After such evidence has been furnished, the Owner shall not materially vary such financial arrangements without prior notice to the Contractor. Also, except for permits and fees which are the responsibility of the Contractor under the Contract Documents, the Owner will secure and pay for necessary approvals, easements, assessments, and charges required for construction, use or occupancy of permanent structures, or for permanent changes in existing facilities. Also outlined are the extent of the owner's right, the owner's right to stop the work and the right to carry out the work.

Contractor Role and Responsibilities: This section lays out the obligations of the contractor under the contract. For example, the Contractor warrants all equipment and materials furnished, and work performed, under the contract, against defective materials and workmanship for a specified period (usually 12 months) after acceptance as provided in the contract, unless a longer period is specified, regardless of whether the same were furnished or performed by the contractor or any subcontractors of any tier. It also includes things like supervision and construction procedures, materials, labor and workmanship, patents, substitutions, record drawings, shop drawings, product data and samples, taxes, permits and contractor's construction schedules. Additionally, the contractor shall, without additional expense to the owner, comply with all applicable laws, ordinances, rules, statutes, and regulations.

Administration of the Contract: This section assigns duties to the architect or as specified for the administration of the contract. Specific clauses dealing with the architect's responsibility for visiting the site and making periodic inspections are included. The section also addresses how requests for additional time, claims and disputes are to be addressed. Generally, the Owner's representative (or Lender's representative) will administer the construction contract. The Architect will assist the Owner's representative with the administration of the contract as indicated in these contract documents. The project administrator will not be responsible for the contractor's failure to perform the work in accordance with the requirements of the Contract Documents.

Subcontracts and Subcontractor Relations: This section deals with the general contractor awarding of subcontracts to specialty contracts for certain portions of the work. The Contractor is required here to furnish the Owner and the Architect, in writing, with the name, and trade for each subcontractor and the names of all persons or entities proposed as manufacturers of products, materials, and equipment identified in the Contract Documents and where applicable, the name of the installing contractor. By appropriate agreement, the contractor shall require each subcontractor, to the extent of the work to be performed by the subcontractor, to be bound to the contractor by terms of the Contract Documents, and to assume toward the contractor all the obligations and responsibilities, including the responsibility for safety of the subcontractor's work, which the contractor, by these documents, assumes toward the owner and project administrator.

Construction by Owner or Separate Contractors: This clause basically states that the Owner reserves the right to perform construction or operations related to the project with the owner's own work force and that the owner has the right to award separate contracts as stipulated in the contract documents. In this respect, No contractor shall delay another contractor by neglecting to perform his/her work at the appropriate time. Each contractor shall be required to coordinate his/her work with other contractors to afford others reasonable opportunity for execution of their work.

Changes in the Work: This section highlights how changes (overhead and profit on change orders; time extensions; inclusions) are authorized and processed. The Owner may authorize written change orders regarding changes in, or additions to, work to be performed or materials to be furnished pursuant to the provisions of the Contract. The amount of adjustment in the contract price for authorized change orders will be agreed upon before such change orders become effective. Likewise, an order for a minor change in the work may be issued by the Architect alone where it does not involve changes to the contract sum.

Time and Schedule Requirements: The Contractor acknowledges and agrees that time is of the essence of this Contract. The contract time therefore may only be changed by a change order. Contract time is the period of time set forth in the contract for construction required for substantial completion and final completion of the entire work or portions of the work as defined in the contract documents. This part of the contract therefore deals largely with issues relating to project startup, progress, and completion relative to the specific project schedule in addition to issues relating to delay (Notice and Time Impact Analysis) and

extensions of time to the contract. The general conditions should clarify certain issues such as, how many days after a delay does a contractor have to give notice, and how is the notice to be delivered (verbally, by mail, by registered mail)?

Payments and Completion: The importance of this section is that it identifies how the contractor will be paid and specifies how applications for progress payments are to be made. The contract sum is stated in the Agreement and with the authorized adjustments reflects the total amount payable by the owner to the contractor for performance of the work under the Contract Documents. Before the first Application for Payment, the contractor shall submit to the architect a schedule of values allocated to various portions of the work, prepared in such form and supported by such data to substantiate its accuracy as the Architect may require. This schedule, unless objected to by the Architect, shall be used as a basis for reviewing the contractor's applications for payment. The owner's representative may decide not to certify payment and may withhold approval in whole or in part, to the extent reasonably necessary to protect the owner.

Protection of Persons and Property: This section of the general conditions addresses safety concerns for both the owner's property and the personnel on the project. According to the AIA form 201, "The Contractor shall be responsible for initiating, maintaining and supervising all safety precautions and programs in connection with the performance of the Contract." It basically means that the contractor shall conduct operations under this contract in a manner to avoid the risk of bodily harm to persons or risk of damage to any property. Moreover, the contractor is required to comply with applicable safety laws, standards, codes, and regulations in the jurisdiction where the work is being performed.

Insurance and Bonds: These issues deal with various insurance and bonding requirements of the parties. For example, the Contractor is required to purchase such insurance as will protect the Contractor from claims which may arise out of or result from the contractor's operations under the contract and for which the contractor may be legally liable, whether such operations be by the contractor or by a subcontractor or by anyone directly or indirectly employed by any of them, or by anyone for whose acts any of them may be liable. Furthermore, the owner shall have the right to require the contractor to furnish bonds covering faithful performance of the contract and payment of obligations arising as stipulated in

bidding requirements or specifically required in the Contract Documents including but not limited to Contractor's obligation to correct defects after final payment has been made as required by the Contract Documents on the date of execution of the Contract.

Uncovering and Correction of Work: This section deals with acceptance of the work in place by the architect or owner's representative and stipulates when the contractor is responsible for uncovering and/or correcting work that is considered unacceptable. The AIA 201 form here states that "If a portion of the Work is covered contrary to the Architect's request or to requirements specifically expressed in the Contract Documents, it must, if required in writing by the Architect, be uncovered for the Architect's examination and be replaced at the Contractor's expense without change in the Contract Time." The Owner may in its sole discretion accept work which is not in accordance with the Contract Documents, instead of requiring its removal and correction. In Such case the contract sum will be adjusted as appropriate and equitable.

Miscellaneous Provisions: This section addresses various issues such as successors and assigns, wage rates, tests and inspections, rights and remedies, codes and standards, records, general provisions and written notice.

Termination or Suspension of the Contract: This section deals with the terms under which parties may terminate or suspend the contract. The Contractor may terminate the Contract if the Work is stopped for a period of 30 consecutive days through no act or fault of the Contractor or a Subcontractor, employees or any other persons or entities performing portions of the Work under direct or indirect contract with the Contractor. Similarly, in addition to other rights and remedies granted to the Owner under the Contract Documents and by law, the Owner may without prejudice terminate the Contract with the Contractor under specific conditions. The Owner may also, at any time, terminate the Contract in whole or in part for the Owner's convenience and without cause.

Lenders will often require general conditions to be disbursed in direct proportion to the percentage of completion of the subcontractual costs so that the Lender is assured that general condition monies will be adequate throughout the project's duration. In some cases, especially in CM and "cost plus a fee" contracts, the Borrower's contract requires that he pays general conditions on either an equal monthly payment or on a cost incurred basis. The Lender should be consulted beforehand to determine the Lender's funding policy.

4.5.6 Supplemental Conditions

The Supplemental Conditions amend or supplement the Standard General Conditions of the Construction Contract and other provisions of the Contract Documents, and whereas general conditions can apply to any project of the type being designed and built, supplemental conditions or special conditions usually deal with matters that are project specific and beyond the scope of the standard general conditions and although they generally augment them. These sections may either add to or amend provisions in the general conditions. Below are examples of project-specific information that may appear in this section:

- Project phasing or special construction schedule requirements
- Safety and security precautions
- Insurance coverage certificates
- Additional bond security
- Cost fluctuation adjustments
- Materials or other services furnished by the owner
- Temporary facilities requirements
- Prevailing wages
- Permits, fees, and notices
- Bonus payment information
- Submittals

4.5.7 The Designer of Record/Administrator Sign Off

Project closeout is the final action to be taken in the construction process. Yet before the Designer of Record (DOR)/Administrator is able to sign off and the owner takes possession of the building, certain requirements need to be met. For final completion and before final payment can be made a number of issues need to be addressed including the following:

- A certificate of occupancy is in place
- All liens of GC/CM and trade contractors are released or satisfied and outstanding claims resolved
- The architect must certify final completion and all “punch-list” items are complete
- The architect must certify that final inspection has been satisfactorily conducted
- All warranties, guaranties, and operating manuals have been received
- Final lien waivers and contractor affidavits are obtained for all work performed—from architect, GC/CM, and trade contractors

- Close-out agreement—complete all outstanding issues with each trade contractor and with the general contractor, and confirm commencement date for guaranty period, etc.
- Commissioning has been satisfactorily completed



4.6 PREPARING THE PSR

Regular PSRs help ensure that the Lender, Owner, and other stakeholders have clear visibility to the true state of a project and that Management stays properly informed about project progress, difficulties, and issues, by periodically getting the right kinds of information and updates from the project manager based on site visits and meetings. Frequent communication of project status and issues is a vital part of effective project risk management. The PSRs should let management and stakeholders know whether the project is on schedule to deliver the project as planned and whether there are issues that need to be addressed.

4.6.1 Draw Applications—Documents Required

The Consultant needs to conduct an inventory and review of construction documents which include, but are not limited to:

- Plat Plan/Boundary Survey/Site Plan
- Topography Plan
- Environmental Site Assessment
- Soils Investigation Report
- Construction Plans
- Construction Specifications
- Addenda/Change Orders
- Construction Contracts(s)/Schedule of Values
- Architect's Contract(s)
- Construction Schedule
- Building Permits
- Foil Documents
- Utility Letters
- Estimated Variances

4.6.2 Waivers of Lien

A lien is a “hold” against your property that, if unpaid, allows a foreclosure action, forcing the sale of your property or home. It is recorded with

the County Recorder's office by the unpaid contractor, subcontractor, or supplier. Sometimes liens occur when the prime contractor has not paid subcontractors or suppliers. Legally, the property owner (Borrower) is ultimately responsible for payment—even if they have already paid the prime contractor. The Borrower (owner) is required to provide copies of all partial/full waivers of lien from subcontractors, vendors, etc., to the Administrator, normally on a monthly basis, usually with the payment application (Fig. 4.7). These partial waivers are to accompany each general contractor and subcontractor requisitions on a monthly basis. While most borrowers execute them on a monthly basis as the project progresses, some prefer to wait until the project is completed and submits them with the final request for payment. In some cases the borrower may request that upon signing the contract the subs waive their right to lien the job. Waivers should be properly organized, stating what trade they are for and included as exhibits in the report. As a project approaches completion, copies should be obtained of all lien waivers. For any that are not forthcoming, recommend to the Lender that they be obtained or deducted from the retainage. The four main types of lien waivers are:

1. Conditional lien waiver and release upon progress payment discharges all claimant rights through a specific date, provided the payments have actually been received and processed, which makes it the safest waiver for claimants.
2. Unconditional lien waiver and release upon progress payment: This waiver unconditionally discharges all claimant rights through a specific date with no stipulations.
3. Conditional lien waiver and release upon final payment: This lien waiver releases all claimant rights to file a mechanics lien with certain provisions if there is evidence that they have been paid to date.
4. Unconditional lien waiver and release upon final payment: This provides the safest type of lien waiver for owners; it generally releases all rights of the claimant to place a mechanics lien on the owner's property unconditionally. However, claimants should issue this type of release only when they are satisfied that their work is complete and that the payment has cleared their bank. Owners should demand this release when claimant is paid in full.

4.6.3 Testing Reports

The review of testing results should normally be undertaken on a monthly basis. A set of Contract Documents should be submitted to the construction testing agency for their review prior to the commencement of any

PARTIAL WAIVER OF LIENS

Project Description: _____

 Period Ending: _____, 20__
 Work Performed: _____
 Work Performed by: _____
 Under Contract to: _____
 Contract Date: _____
 Original Contract Amount: \$ _____
 Change Order Amounts: + _____
 Adjusted Contract Amount: \$ _____
 Work Completed to Date: \$ _____
 Less Retainage Not Yet Due: - _____
 Net Amount Due to Date: \$ _____
 Less Payments Received to Date: - _____
 Total Payment Due: \$ _____

THE UNDERSIGNED (1) acknowledges receipt of the amount set forth above as payments received to date, (2) to the extent of such payments, waives and releases any claim which it may now or hereafter have upon the land and improvements described above in the project description, (3) that the amount of payments received to the date of this waiver represents the current amount due in accordance with our contract and work completed, and (4) warrants that it has not and will not assign any claims for payment or right to perfect a lien against such land and improvements and warrants that it has the right to execute this waiver and release.

THE UNDERSIGNED further warrants that (1) all workman employed by it or its subcontractors upon this Project have been fully paid to the date hereof, (2) all materialmen from whom the undersigned or its subcontractors have purchased materials used in the Project have been paid for materials delivered on or prior to the date hereof, (3) none of such workman and materialmen has any claim or demand or right of lien against the land and improvements described above, and (4) stipulates that he is an authorized officer with full power to execute this waiver of liens.

THE UNDERSIGNED agrees that _____ and any lender and any title insurer may rely upon this waiver.

 By _____
 Title _____

Sworn to me this ____ day
 of _____, 200__.

 Notary Public

NOTE: Return four (4) signed releases to _____ at _____, _____, _____ to the attention of _____ . Additional payments will not be made until the signed releases are returned.

Figure 4.7 Example of a partial waiver of liens.

construction. The testing agency will provide a copy of their current rate schedule for types of test work and also provide a budget estimate for the specific project for the Owner's review and to make a determination. Upon the owner's acceptance and approval, the owner and/or Administrator will authorize the testing agency in writing to proceed with required tests. After the administrator reviews the billing with the owner and/or architect, it is given to the owner for payment. The contractor's is responsible for coordinating and scheduling required testing activities for the project. The different types of testing reports received (concrete, mortar, timber, etc.) should be recorded and whether or not they're in compliance with the design specifications. Any test results that fail should be brought to the attention of the owner requesting an explanation before deciding what action is to be taken. A letter may be sent to the DOR noting the failed test and requesting comment, depending on the test's significance and its impact on the project.

The Owner needs to provide the Administrator with copies of all controlled testing reports. The testing agency normally provides test reports within 48 h to the Administrator, designated engineering consultants, contractor, and owner. It is the Administrator's duty to immediately respond, in writing to any test reports that indicates that the work fails to conform to the Contract Documents and to ensure that remedial action is taken. Since the contractor is ultimately responsible for the construction means and methods, it becomes the contractor's responsibility to propose a solution to rectify any construction deficiencies.

4.6.4 Daily Work Log

The day-to-day activities that take place on the job site are generally monitored with the use of daily work logs. The owner should provide a copy of a typical page from the project's daily work log for the day prior to the Administrator's site visit and meeting. The contractor's daily log will normally be submitted to the Administrator on a weekly basis. It will typically contain:

1. Daily activities
2. Meetings and important decisions
3. Unusual events such as stoppages, and emergency actions
4. Material delivery, equipment on site, etc.
5. Visitors
6. General weather conditions
7. Conversation and telephone records

8. Problems or potential delays
9. Accidents
10. Change orders received (pending or implemented)

4.6.5 Construction Schedule and Schedule of Values

Project Schedules are to be provided which consist of monitoring the progress of the contractor and subcontractors relative to established schedules and making status reports to the owner. Upon reviewing them, the Administrator may discuss how the project stands with respect to the owner's construction schedule and/or the target date for completion. Any factors contributing to delay or progress should be mentioned (e.g., good weather, a strike, tight management, etc.). If the initial construction schedule is revised, the owner should submit a copy of the revised schedule to the Administrator. Fig. 4.8 is a construction schedule to monitor how the work is progressing in relation to the contractor's schedule. The Project Construction Schedule shall be prepared in accordance with the Contract Documents in either PERT, BAR, GANTT, or C.P.M. format. The Project Construction Schedule shall be updated each period by the Contractor and

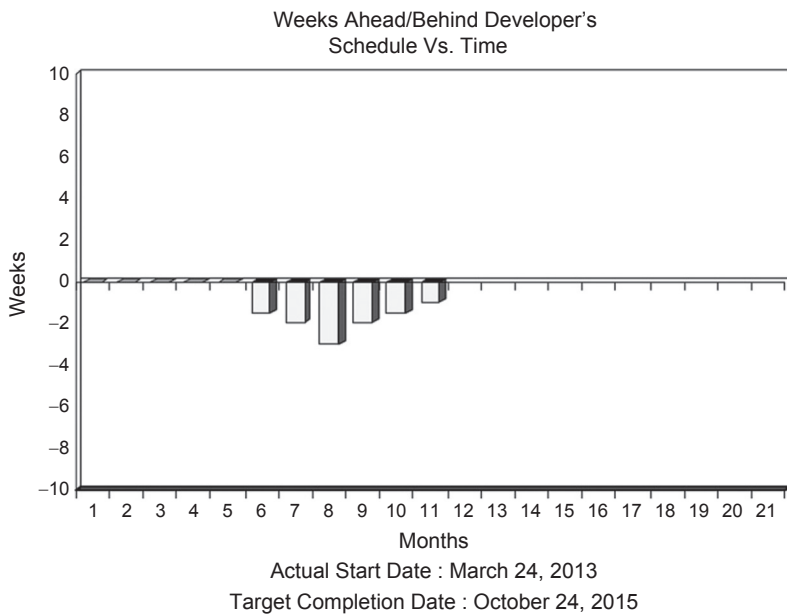

Figure 4.8 Typical construction schedule with an actual start date of March 24, 2012, and a target completion date of October 24, 2015.

verified by the Administrator to ensure that the schedule is always up to date and accurate. The updated Project Construction Schedule shall form part of each monthly Application for Payment and shall also be included in the Administrator's monthly PSR.

A schedule of values is a list with the dollar amount assigned to each area of work that will be completed on a construction project. It shall be prepared in accordance with the Contract Documents and which equals the total cost of the project. Line items for the Schedule of Values shall be divided into the appropriate specification divisions and broken down to reflect material and labor costs for each item. Unit measurement for the materials described in the Schedule of Values shall be included. These numbers will be required to estimate the value of work in place at any specific time. The Schedule of Values for the project will ultimately become the source for verifying costs for any additional work and establishing prices for potential modifications to the Contract Documents (Change Orders). Schedule of values ConsensusDOCS 293 form which provides a breakdown of the cost of elements of the work can be used with the ConsensusDOCS application for payment forms ConsensusDOCS 291 and 292.

4.6.6 Project Progress Meetings

Periodically and depending on the project, various meeting will take place at the job site throughout the construction process, most of which are well scheduled in advance. Depending on the type and size of project and the agreement between the Lender and the Administrator, these meetings are usually held at regular intervals, usually on either a bi-weekly or monthly basis unless an unscheduled special meeting is called to address special issues. The main purpose of these meetings is to discuss and review the project's progress and to provide a forum in which the main participants (administrator, contractor, subcontractor, architect, engineers, and others) can discuss their concerns as well as a submitted application for payment. These meetings are usually chaired by the project Administrator and can be fairly formal in nature with a written agenda. Meetings are normally recorded and the minutes are distributed to all the participants within a week of the specified meeting.

4.6.7 Stored Materials Funding and Documentation

It is necessary for all materials stored on site be in a secured area. Where the contractor is requesting funds for stored materials, a stored materials schedule for such materials should be delivered to the PM and the Application

for Payment and Sworn Statement of General Contractor (AIA Document G702) or equivalent document must list the dollar amounts of all stored materials. All such items must be verifiable by the Consulting Professional.

This section is included only if there are materials for which funding has been requested by the general contractor that are stored either on or off site (Fig. 4.9). Where funding is permitted, typical documentation that is required by the owner or lender should be provided in order to approve funding. And where the Contractor seeks payment for materials that have not been incorporated into the improvements and are not stored on site, the following back-up documents are required in order to process the request:

1. A stored materials statement for the off-site or on-site materials.
2. Evidence of insurance on the stored material (whether at the off-site location or in transit). Identify the type of material, value, and location.
3. Bill of Sale evidencing Borrower's ownership of the stored materials, including a list of materials, value, and location.
4. Letter from the Consulting Professional or approved third party inspector stating that materials have been sighted and inventoried and that they are suitably stored and marked for the project in question.
5. Materials stored off-site shall be in an independent bonded warehouse with prior approval of the owner or lender and at no cost to the owner/lender.
6. Any material having architectural finishes will require inspection and acceptance by the Architect. In no case will payment be made for bulk marble, granite, etc., that has not been fabricated and inspected.

Furthermore, the owner or lender may approve funding for stored materials under certain conditions such as in cases where ordering of materials require a long lead time. Items that are being fabricated and stored with the manufacturer should also be marked and segregated from the manufacturer's other supplies. Prior to request for payment on materials "in process" being fabricated, the Architect or other firm or agency acceptable to the Lender should inspect the materials and preferably document the inspection with appropriate photographs.

4.6.8 Subcontracts and Purchase Orders

Subcontracts and purchase orders are typically signed during the general course of construction, and thus copies of these should be provided to the Administrator. If this is a general contractor built project where subcontracts are not to be made privy to the owner, then the Lender usually requires copies of all major subcontractor trade payment breakdowns prepared on a percentage of completion basis instead of a dollar amount.

4.6.9 Payment and Performance Bonds

To assure the owner that the contractor will complete all obligations set out in the contract, a Performance Bond is often stipulated in the general conditions provided that no action by the owner or the owner's agents prevents or inhibits the contractor from the implementation of the contract requirements. However, it appears that lending institutions have started to lessen their emphasis on "bonded" contracts. A number of lenders have been disappointed to find they are involved in extended litigation after invoking the very bond they looked to for protection. Moreover, bonding companies often will not bond an owner-builder. Although a number of title companies previously offered a "completion guarantee" designed to assure interim lenders that their project would be completed, but due to suffering extensive losses these title companies have largely withdrawn such policies. Indeed, the most perilous and defining phase of the delivery of a new project is the actual construction. The construction phase, due to the infinite number of inherent risks associated with the activity, rises far above the other phases of the project delivery when claims, failures, problems, and defaults are taken into consideration.

In all cases, the Administrator should be aware of both the Owner's rights (and Lender's rights) under the Contract as well as the obligations necessary to protect those rights. Should the Administrator, while acting as the Owner's agent in administering the new project, fail to properly ensure the rights of the Owner due to negligence of the requirements, incorrect documentation or the untimely issuance of notice, the Administrator may certainly be held liable by the Owner and will be held responsible for any losses whether moral or financial. The Administrator should also be aware of all requirements necessary to ensure the protection of the payment and performance bonds. As a construction expert and owner's representative, the Administrator's role in administering the construction contract requires verification of all notices that are made and that all prerequisites are followed by both the Owner and Contractor.

Default by the contractor during the construction phase of the project is considered the greatest potential risk for both Owner and Lender. For this reason, it is important for the successful project Administrator to exercise both caution and diligence while reviewing the types of payment and performance bonds required by the contract. Normally, the Administrator should specify standard AIA bond forms A312 (Performance and Performance Bonds) or equivalent; these documents are not only respected by the Surety industry, but have been thoroughly tested and generally upheld through

the judicial process. Separate payment bond and performance bond with separate bond numbers and power of attorney offer the Owner protection equal to double the face value of the construction project. It may be wise to avoid use of combination payment and performance bonds because of recent legal precedents that have held that the surety was obligated to pay only the face value of the construction project through a combination of claim against both sides of the combined bond.

Payment and performance bonds offer the owner the appropriate protection against countless scenarios of contractor default, subcontractor nonpayment, material or supplier nonpayment and liens, yet the Administrator should also recognize the surety and its agents for what they really are—sharp and intelligent businessmen who will carry out all their obligations and responsibilities under the bonds, provided all aspects of the default are in fact the contractor's responsibility. However, the surety may be relieved from their obligations, in whole or in part, by the erroneous actions or negligence of the Administrator or the improper actions of the Owner, in which case the surety may try to mitigate their losses to the maximum extent possible under the law. Thus by the time the surety becomes involved in a construction project, the relationships between the Owner, Contractor, and Administrator may very well be uncomfortable to say the least. The surety certainly is not a deep pocketed, sympathetic benefactor that doles out money to those most deserving, just because there is a payment and performance bond.

It is necessary for the Administrator to read and understand the wording and requirements of each type of bond, for just as every project is unique so is every situation involving the surety. There is no substitute for studying and fully understanding the requirements of the bond to ensure that each and every action required by the Administrator is not only fully implemented but fully implemented within the specified time frames delineated in the bond documents. It should also be noted that the statements and opinions expressed herein reflect a general attitude of surety and its general position when confronted with differing construction situations. However, the reader should be alerted to the fact that these opinions are not intended to be legal advice but rather are generic in nature.

4.6.10 RFI and Other Logs

The contractor will sometimes issue RFIs to the Administrator or owner for clarification of design information or to present any other questions; it

includes a summary log containing the status of each request. It is a formal procedure and each inquiry and response should be tracked and documented. To avoid potential litigation, it is critically important to get a quick response. They often originate from a subcontractor, vendor or craftsmen who need certain information to continue working. Most contractors have a standard format that they use to keep the RFIs consistent throughout the contract.

4.6.11 Permits and Approvals

Prior to the commencement of any building construction, the owner is required to apply and receive a building permit for the project from the local authority. This may be the single most critical aspect of the preconstruction process; sometimes it is acquired prior to the bidding process. A delayed permit can cause considerable hardship and project complications. Building permits also contain inspection schedules and zoning ordinance for the project. A copy of the ordinance under which project was approved as well as copies of all variances, approvals and declaration, and any other zoning information or approvals pertinent to the project should be in the possession of the owner, DOR, and the Administrator. Other permits and approvals need to be provided such as:

- A print of the zoning sheet should be included which highlights all calculations along with evidence that the zoning computations have been approved by the planning board.
- A comprehensive list of all permits necessary to be able to proceed with the construction of the proposed improvements prepared by the DORs. Additionally, copies of all permits secured to date with the remaining provided, as and when they are available.
- A complete list of all agreements between the borrower (owner) and any governmental agreements and between the borrower and any governmental agencies for the construction of the suggested changes and copies of all agreements.
- Copies of all appropriate approval/permits from the Landmarks Commission, Historical Preservation Group, and other related agencies for historical renovation and restoration work.
- Statements of Existing Certificate of Occupancy and/or Certificate of Occupancy (“CO”) procedures and any special requirements to obtain a CO upon completion of the work. Also to be noted if any temporary COs (TCOs) have been issued for partial or phased completion.

- Schedule of Building Code Violations if any.
- Copies of utility load calculations prepared by the engineers-of-record and confirmation that existing services are or are not adequate to serve the proposed project in addition to confirmation from the appropriate authority of availability, adequacy, and intent to provide the following utilities for the proposed project: (1) Water, (2) Gas, (3) Electricity, (4) Steam, (5) Sanitary Sewers, and (6) Storm Sewers.



4.7 FINAL CERTIFICATION AND PROJECT CLOSEOUT

Project close-out and final acceptance phase can be initiated upon receiving notice from the contractor(s) that the work or a specific portion thereof is acceptable to the Owner and is sufficiently complete, in accordance with Contractor Documents, to allow occupancy or utilization for the use for which it is intended and can take place when all contract requirements, warranty, and close-out documents along with all punch list items have been resolved. Normally, a “punch list” of unfinished and/or defective work complete with remedial cost is prepared for possible escrow purposes. Upon the owner’s request for the final loan advance, the Administrator collates and examines all permits, approvals, waiver of liens, and other close-out documents specified in the loan agreement. Upon approval of these documents, the Administrator makes another site inspection and verifies and certifies that the work was completed in accordance with the plans, specification, and loan agreement and there are no outstanding issues on the matter.

Documents typically required for project closeout include the following:

1. As-Built signed/sealed record drawings, which show all changes from the original plans
2. As-Built Record Specifications—Contractor’s Certificate of Compliance with Plans and Specifications
3. Architect’s issuance of Certificate of Substantial Completion and/or final acceptance and issuing final Certificate(s) for Payment after a detailed inspection with the Owner’s representative is conducted for conformity of the work to the Contract Documents to verify the list submitted by the Contractor(s) of items to be completed or corrected
4. Architect’s certified copy of the final punchlist of itemized work stating that each item has been completed or otherwise resolved for acceptance

5. Determination of the amounts to be withheld until final completion of outstanding punchlist items
6. Notification to Owner and Contractor(s) of deficiencies found in follow-up inspection(s), if any
7. Certification from Borrower that all close-out requirements including but not limited to, as-built drawings, warranties, operating and maintenance manuals, keys, affidavits, receipts, releases, etc., have been received, reviewed as necessary, and approved for each subcontractor
8. Completed Commissioning and Closeout Manual
9. Record of Approved Submittals and Samples
10. Certification of No Asbestos Products Incorporated in Project.
11. Certificates of Use, Occupancy, or Operation
12. Securing and receipt of consent of surety or sureties, if any for reduction or partial release of retainage or the making of final payment(s) and consents of surety for final payments, if bonds are provided
13. Final release of claims and waivers of lien in a form satisfactory to lender and the title company from all subcontractors, suppliers, and the general contractor and indemnifying the Owner against such liens
14. Affidavit of payment of Debt and Claims

4.7.1 As-Built Drawings/Record Drawings

Contractor must furnish as-built record drawings made from the Architect/Engineer's Contract Drawings, or subsequent updates thereof, annotated and with actual as-built conditions. Most contracts stipulate that the contractor maintains a set of As-Built (sometimes erroneously called record drawings) as the project progresses. As-built drawings record actual dimensions, locations, and features that may differ from the original contract documents and must show all changes in the Work relative to the original Contract Documents; as well as additional information of value to Owner's records but not indicated in the original Contract Documents. When the drawings are in an electronic format, the contractor may be required to correct the drawing files and highlight the modifications. An example of this is the location of underground utilities which differs from the original drawings. In such cases, the contractor would be directed (normally in writing) to make the change, whereas the design professional fails to make the necessary modification as they are the responsibility of the general contractor. It is usually stipulated that the contractor submits a final complete and accurate set of as-built drawings to the owner prior to receipt of final payment.

As-Built plans represent the existing field conditions at the completion of a project. Accurate project plans are sometimes needed for possible litigation involving construction claims and tort liability suits.

The most qualified individual to note the field changes that occurred (called “redline corrections”) is usually the Resident Engineer, architect, or BIM Manager of a completed project. As-Built plans are preferably completed within the project using an electronic format such as AutoCad or MicroStation. Having the drawing saved as a CADD or other digital system file makes it easier to store and update whenever necessary.

4.7.2 Contractor’s Certificate of Compliance

Certificates of Compliance can apply to various issues such as discrimination and affirmative action, subcontractor work, etc. The general contractor must agree and certify compliance with applicable requirements of the contract documents. The Certificate of Compliance is valid for a limited time, say, 180 days, and it is the responsibility of the contractor to renew the Certificate prior to the expiration date, while the project is still in the construction phase. Temporary Certificate of Compliance may often be issued for a portion or portions of a building that may safely be utilized prior to final completion of the building. In this respect the contractor also agrees to obtain compliance certifications from proposed subcontractors prior to the award of subcontractors exceeding an agreed sum as per contract documents. Furthermore, the Contractor is required to coordinate the efforts of all subcontractors and obtain any required letters of compliance from the Administrator or Owner’s consultant. The Owner is usually required to pay any fee associated with these letters. However, the Contractor shall reimburse the Owner for any costs resulting from failed tests or inspections conducted to obtain a letter of compliance. This reimbursement procedure is spelled out in the contract documents, and should be made as part of a credit change order.

4.7.3 Architect/Administrator’s Certificate of Substantial Completion

The Contract Documents will define the date of Substantial Completion and is considered to be the date which the Administrator, Owner, and/or Architect will certify that the work, or designated portion of the work, may be beneficially occupied or utilized by the Owner for its intended use. For this purpose, the AIA G704 standard form is used for recording the date of

substantial completion of the work or a designated portion thereof. This process takes off when the Contractor considers the work, or designated portions of the work as previously agreed to by the Owner, is substantially complete; The contractor then prepares and submits to the Administrator a punch list of items which remain to be completed or corrected. The AIA G704 form provides for agreement the time to be allowed for completion or correction of the items and the date when the owner will be able to occupy the project or designated portions thereof. The form will also designate responsibility for maintenance, heat, utilities, and insurance. If the Administrator concludes that the work is substantially complete, the AIA form is then prepared for acceptance by the contractor and owner. The failure of the contractor to include any items on the list will in no way alter his responsibility to complete or correct these items per the Contract Documents. Likewise, where there is no architect to certify substantial completion, the AIA Document G744–2014 can be used which requires the owner to inspect the project to determine whether the work is substantially complete in accordance with the design-build documents and to identify the date when it occurs. The AIA Document G744–2014 is a variation of AIA Document G704–2000 and provides a standard form for the owner to certify the date of substantial completion.

There are variations of the G704–2000 such as the G704CMa–1992, Certificate of Substantial Completion, the Construction Manager-Adviser Edition serves the same purpose as G704–2000, except that this document expands responsibility for certification of substantial completion to include both the architect and the construction manager. There is also the G704DB–2004 which is a variation of G704–2000 that acknowledges Substantial Completion of a Design-Build Project. Because of the nature of design-build contracting, in this form the project owner assumes many of the construction contract administration duties performed by the architect in a traditional project. Because there is no architect to certify substantial completion, the AIA Document G704DB–2004 requires the owner to inspect the project to determine whether the work is substantially complete in accordance with the design-build documents and to acknowledge the date when it occurs. In addition as an alternative to the AIA documents for a Certificate of Substantial Completion for Design-Build Work, the Owner and Designer-Builder can use ConsensusDOCS 481 and for a Certificate of Final Completion for Design-Build Work ConsensusDOCS 482 can also be used.

Use of the term “beneficial occupancy” generally is an indication that the project or portions thereof are complete to a sufficient degree to allow the Owner to utilize the project or portions thereof, for their intended usage. Relevant systems such as the mechanical systems, life safety systems, telecommunications systems, and any other systems which are required to properly utilize the project or portions thereof, shall be complete and in good working order. Items remaining to be completed shall be such that their correction does not inconvenience or disrupt the Owner’s normal operations at the site.

The Owner/Lender or their representative (Administrator) should be consulted to confirm that there are no other evident construction deficiencies that are not on the contractor’s punch list. It is very important to emphasize that responsibility for preparing the original punch list lies with the Contractor. If the Administrator is requested to make a Substantial Completion inspection, and it is obvious that the contractor’s punch list is incomplete, the inspection shall be discontinued and of which the contractor advised.

The Certificate for Substantial Completion should not be issued until the Administrator can verify that the following conditions are in place:

- Written statement from the Contractor that the project or designated portion thereof is substantially complete or that construction is sufficiently complete for beneficial occupancy by owner (with relevant lien waivers).
- Correctly executed Consent of Surety for Reduction in Retainage per the Contract Documents is in place.
- Contractor’s “Punch List” with Administrator’s supplementary comments added. However, prior to any retainage being released Administrator must certify substantial completion and Administrator (or DOR), general contractor and owner must agree upon “punch-list” work to be completed.
- TCO from appropriate agency with all required permits/approvals.

Normally there is a Lender involved in the project, and the Certificate of Substantial Completion shall be prepared by the Administrator and certified by the Owner and/or Architect, prior to being submitted to the Owner and the Contractor for their written acceptance of the responsibilities assigned them in the Certificate. The Certificate of Substantial Completion shall also establish the dates and responsibilities of any transitional arrangements which will be required between the Owner and the Contractor.

4.7.4 Architect/Administrator's Certified Copy of Final Punchlist

The Contractor's final punchlist will be given to the Administrator for review of the list and the completed work to determine whether the list is both accurate and complete. Items which require correction and/or completion, that are not included in the contractor's punchlist, shall be supplemented by the Administrator. The Owner should be informed that the items on the punch list shall be rectified and/or completed within the time limit set forth in the Certificate of Substantial Completion. The Contractor shall also be advised that any correction and/or completion of punch list items shall be conducted in a manner so as not to adversely affect or disrupt the Owner's occupancy of the facility.

4.7.5 COs, Use, and Operation

A CO is a document issued by a local government agency or building department certifying that the building in question complies with all applicable building codes, safety codes, health code requirements, and other laws, and basically stating that the building is in a condition suitable for general occupancy. The procedure and requirements for the CO vary widely from jurisdiction to jurisdiction and on the type of structure. In the United States, obtaining a certificate is generally required whenever a new building is constructed, or when a building built for one use is to be used for another (e.g., an industrial building is converted for residential use). Likewise, a certificate is required when the occupancy of a commercial or industrial building changes, or ownership of a commercial, industrial, or multiple-family residential building changes. The purpose of this certificate therefore is to document that the use is permitted, and that all applicable safety code and health code requirements have been met.

A Use and Occupancy Certificate is required for the space to be used prior to opening any business. It is also generally necessary both to be able to occupy the structure for everyday use, as well as to be able to sign a contract to sell the space or close on a mortgage for the space. A CO is proof that the building complies substantially with the plans and specifications that have been submitted to, and approved by, the local authority. It basically complements a building permit, that document that is filed by the applicant with the local authority before commencement of construction to signify that the proposed construction will adhere to all relevant ordinances, codes, and laws. Particular attention should be paid to the new IgCCs and whether they apply.

Often a TCO will be applied for. This grants residents and building owners all of the same rights as a CO, except that it is valid only for a temporary period of time. In New York City, for example, TCOs usually expire 90 days from the date of issue although it is not uncommon and perfectly legal, for a building owner to re-apply for a TCO, following all the steps and inspections required originally, in order to extend their TCO for another period of time. Temporary Certificate of Occupancies are generally sought after and acquired when a building is still under minor construction, but where there is a certain section or number of floors in a building that are considered to be habitable (e.g., in a high-rise apartment building), and upon issuance of a TCO, can legally be occupied or sold.

4.7.6 Final Waivers of Lien

Once the project in hand is finished, the contractor is usually required to complete a final lien waiver (Fig. 4.10). The general contractor is also required to obtain conditional final waivers from each subcontractor, vendors, and certain individuals prior to final payment being released. A final lien waiver is basically a document from a contractor, subcontractor, material supplier, equipment lessor, or other parties to the construction project stating they have received full payment and waive any future lien rights to the property. It should be noted that in the United States, liens cannot be filed against public property. Moreover, some states only use a conditional waiver on progress payment and an unconditional waiver on final payment.

The mechanics lien process can prove extremely valuable to contractors, subcontractors, material suppliers, and other related parties to a construction project in enforcing their claims, if done according to the laws of the various states, or the federal government. These parties are entitled to be paid for their material or labor contributions to the improvement of real property. Most lien waiver forms for the process can be obtained online or from local office supply stores or professional organizations like the AIA.

4.7.7 Miscellaneous Issues

Commissioning and Warranties

Establish commissioning procedures and date for the commencement of all warranties. Commissioning and warranty review services to consist of:

- Monitoring compliance by GC/CM with commissioning of operating systems, etc.; GC/CM must obtain from trade contractors and give owner all required warranty documents and operating manuals; “as-built” (record) drawings; etc.

(a) CONTRACTOR/VENDOR FINAL RELEASE AND LIEN WAIVER

The undersigned represents and warrants that it has been paid and has received (or that it will be paid and will receive via proceeds from this pay application) \$ _____ as full and final settlement under the contract/agreement dated _____ (including any amendments or modifications thereto) (the "Contract") between the undersigned and _____ ("Contractor/Vendor") for the _____ Project owned by _____ ("Owner") (PO Number: _____). In consideration for this final payment, and other good and valuable consideration, receipt of which is acknowledged, the undersigned makes the following representations and warranties:

1. The undersigned and Owner have fully settled all terms and conditions of the Contract (including any amendments or modifications thereto), as well as any other written or oral commitments, agreements, and/or understandings in connection with the Project.
2. The undersigned has been paid in full (or it will be paid in full via proceeds from this pay application) for the labor, services, and materials in connection with the Contract, including all work performed or any materials provided by its subcontractors, vendors, suppliers, materialmen, laborers, or other persons or entities.
3. The undersigned has paid in full (or it will pay in full via proceeds from this pay application) all its subcontractors, vendors, suppliers, materialmen, laborers, and other person or entity providing services, labor, or materials to the Project; there are no outstanding claims, demands, or rights to liens against the undersigned, the Project, or the Owner in connection with the Contract on the part of any person or entity; and no claims, demands, or liens have been filed against the undersigned, the Project, or the Owner relating to the Contract.
4. The undersigned releases and discharges Owner from all claims, demands, or causes of action (including all lien claims and rights) that the undersigned has, or might have, under any present or future law, against Owner in connection with the Contract. The undersigned hereby specifically waives and releases any lien or claim or right to lien in connection with the Contract against Owner, Owner's property, and the Project, and also specifically waives, to the extent allowed by law, all liens, claims, or rights of lien in connection with the Contract by the undersigned's subcontractors, materialmen, laborers, and all other persons or entities furnishing services, labor, or materials in connection with the Contract.
5. The undersigned shall indemnify, defend, and hold harmless Owner from any action, proceeding, arbitration, claim, demand, lien, or right to lien relating to the Contract, and shall pay any costs, expenses, and/or attorneys' fees incurred by Owner in connection therewith.

The undersigned makes the foregoing representations and warranties with full knowledge that Owner shall be entitled to rely upon the truth and accuracy thereof.

DATED:

(Contractor/Vendor company name)

By:

Title:

STATE OF _____
COUNTY OF _____

I, a Notary Public for the above County and State, certify that _____ personally came before me this day and acknowledged that he/she is _____ [title] of _____ [company name], and that he/she, as _____ [title], being authorized to do so, executed the foregoing on behalf of _____ [company name]. Witness my hand and official seal this ____ day of _____, 20____.

Notary Public

My Commission Expires:

NOTICE: THIS DOCUMENT WAIVES RIGHTS UNCONDITIONALLY AND STATES THAT YOU HAVE BEEN PAID FOR GIVING UP THOSE RIGHTS. THIS DOCUMENT IS ENFORCEABLE AGAINST YOU IF YOU SIGN IT, EVEN IF YOU HAVE NOT BEEN PAID.

Figure 4.10 (a, b) Two examples of final waiver of lien formats.

(b)

FINAL WAIVER OF LIENS

Project Description:

Contract Date:
Work Performed:
Work Performed by:
Under Contract to:

Listed below is the final information regarding the above contract:

Contract Price	\$ _____
Net Extras/Deductions	+ _____
Adjusted Contract Price	\$ _____
Amount Previously Paid	- _____
Balance Due-Final Payment	\$ _____

The undersigned, being duly sworn, deposes, certifies and says that:

(i) He (She) is an officer of, and is duly authorized to make this affidavit, waiver and release on behalf of _____ ("Contractor").

(ii) Contractor has received in full all payments (plus applicable retention) due through the date of this instrument for all labor, services, equipment and materials (sometimes referred to as the "work") furnished to _____ ("Owner") on the job of above project.

(iii) Contractor has paid in full or otherwise satisfied all of its obligations for labor, materials, equipment and services and all other indebtedness associated with the performance of Contractor's work on the Project, including without limitation payment in full to, or other satisfaction of, all persons and entities (the "Subcontractors") which have furnished labor, services, equipment or materials to Contractor.

(iv) In consideration of the payments received, and upon receipt of the applicable retention, Contractor forever waives, releases and relinquishes any and all claims and rights to a mechanic's lien, stop notice, bond right, equitable claim or right to any fund, and right to a labor and material bond or other bond on the Project and all other rights and claims that Contractor has on the Project.

(v) Contractor guarantees to Owner that the work furnished by Contractor (including work furnished by the Subcontractors) on the Project is and, after receipt of the applicable retention, shall be lien free, that the Subcontractors have no right to any mechanic's lien, stop notice, bond right, equitable claim or right to any fund, any right to a labor and material bond or other bond on the Project or other rights and claims with respect to the Project, and Contractor agrees to indemnify _____ and _____ against any claim or lien asserted through or under Contractor with respect to the Project, including without limitation any claim or lien asserted by any person who has furnished labor, materials, equipment or services to Contractor.

(vi) The undersigned further guarantees that all portions of the work furnished and installed by them are in accordance with the contract and that the terms of the contract with respect to these guarantees will hold for the period specified in said contract.

Sworn to me this _____ day of _____, 200__.

By _____
Title _____

Notary Public

NOTE: Return four (4) signed releases to _____ at _____, _____ to the attention of _____. Payment will not be made until the signed releases are returned.

Figure 4.10 Cont'd

- Consultation and recommendation to the Administrator and Owner during the duration of warranties in connection with inadequate performance of materials, systems, and equipment under warranty
- Inspection(s) prior to expiration of the warranty period(s) to evaluate adequacy of performance of materials, systems, and equipment
- Documenting defects and/or deficiencies and assisting the Owner in providing instruction to the Contractor(s) for rectifying noted defects and deficiencies.

Architect's Supplemental Instructions

The Project Architect/Administrator may issue additional instructions or authorize minor changes in the work not involving an adjustment in cost or requiring an extension of time by issuing a document called the Architect's Supplemental Instructions (ASI), and are often documented by AIA document, ASI G710. It is intended to assist the project architect and administrator in performing its obligations as interpreter of the contract documents in accordance with the owner-architect agreement and the general conditions. The Administrator will prepare and issue an ASI for all additional work that is not included in the Contract Documents and which will not modify the contract sum or extend the contract time. Additionally, such changes shall be effected by a written order signed by the Architect/Administrator or Project Manager directing the Contractor to execute the work promptly.

All ASIs need to be recorded in the Project Log Book. The Administrator may prepare the ASI for the Owner and/or Architect's signature. The Administrator is generally encouraged whenever possible to try and resolve small incidental issues by means of the ASI. The ASI shall be forwarded to the Contractor for signature as an acknowledgment that the work described will not modify the contract sum or contract time.

Time Extensions

In many projects the contractor may feel during the course of the construction process a need to put forward a request for an extension in the contract time. This can be for one of several legitimate reasons that are totally beyond the control of the Contractor such as:

- Inclement weather
- Owner requested changes or additions to the original scope of the work (e.g., Change Order or Construction Change Directive)
- Delays caused by slow responses to RFIs
- Late material shipments from suppliers
- Slow processing of submittals or shop drawings
- Labor strikes

Inclement weather is one of the most common requests for time extensions. The Contractor should make allowances for a normal amount of severe weather in the project construction schedule. Time extensions are granted only for abnormally severe weather, defined as weather which was both detrimental to construction activities and more frequent than usually experienced during that time of year. It is important to note that adverse weather during certain phases of construction (e.g., pouring of concrete floors or foundations) can affect the construction schedule more

adversely than good weather can benefit the construction schedule during other phases. The Contractor is typically required by the Construction Documents to notify the Administrator, Owner, and/or Architect of any potential claim for additional time, due to delay, within 20 days of the commencement of the delay. When reviewing claims for time extensions, the Contractor's daily log should be reviewed to verify that the bad weather occurred during the specified date and that lost time for that period was actually what the Contractor experienced.

Time extensions requested for delinquent or late material deliveries should be verified and the contractor should be asked to furnish verification of the original date for which the material order was placed. In many cases, the contractor or the subcontractor failed to place the order in sufficient time to ensure the delivery of the material meets the contractor's schedule. Time extensions may consist of simple requests for extensions of time or the requests may be more complex and include a request for cost reimbursement related to the extra time request. Except for exceptional circumstances, it may be prudent to try and retain all time extension requests until the project's completion.

Shop Drawing Submittal and Review Procedure

The purpose of the Shop Drawing submittal process is to ensure that the products, materials, equipment, etc., provided, are in compliance with the contract documents which is why the review and approval of Shop Drawing submittals are required prior to fabrication, installation, and/or use of the submitted product. Furthermore, the importance of this process cannot be overemphasized because a delay in this process can cause a delay to the overall completion of the project. There are many items associated with construction that cannot be ordered out of a product brochure or off the shelf. In many cases items need to be fabricated in a shop or manufactured specifically for the project. To confirm the owner's intent, "shop drawings" are required which are essentially the supplier's or fabricator's version of information shown on the drawings in the contract documents. The review and approval of shop drawings is a careful and methodical process. Shop drawings are typically submitted by subcontractors or vendors and contain greater detail and configurations of the item in question sufficient to fabricate and erect the item. Shop Drawing submittals also include design drawings, detailed design calculations, fabrication, installation drawings, erection drawings, lists, graphs, operating instructions, catalog sheets, data sheets, samples, schedules, and similar items. Once completed, they are submitted

to the general contractor who sends them off to the project Administrator (or architect) for final approval. Upon approval they are returned to the general contractor and subcontractor for fabrication.

Many items in the construction process including steel rebar bends, steel beams, trusses, architectural woodwork, and ornamental metalwork require shop drawings. In the case of structural steel, for example, shop drawings may include welding details and connections that are not typically part of the structural engineer's drawings. The term submittal often refers to the totality of the shop drawings, product data and samples; all of these documents are submitted to the owner or owner's representative for approval prior to fabrication and manufacturer of the items they represent. Once approved, submittals may become part of the contract documents and should be incorporated into a submittal log. To be included in the contract documents the shop drawings must have been in existence at the time of the signing of the construction contract and were incorporated by reference into the contract, and also drawings that are added later as contract modifications and that are signed by the owner and the contractor, such as change orders and construction change directives.

Arthur F. O'Leary, author of *A Guide to Successful Construction*, and *Learning To Live With This "Necessary Evil"* says "To the construction industry, shop drawings seem to be a necessary evil. Contractors find them expensive to produce and architects find them unappealing to review. Both find them time-consuming and costly to administer. We seemingly cannot construct buildings without them; but they have become a perennial source of annoyance and confusion and more importantly, a significant source of professional liability claims against architects. Undiscovered mistakes in shop drawings will often lead to unexpected or undesired construction results as well as exorbitant economic claims against architects, engineers, and contractors. Some shop drawing anomalies have resulted in costly construction defects, tragic personal injuries, and catastrophic loss of life."

O'Leary goes on to say, "The principal reason architects and engineers need to review the shop drawings is to ascertain that the contractor understands the architectural and engineering design concepts and to correct any misapprehensions before they are carried out in the shop or field. They review shop drawings of any particular trade or component to determine if the contract drawings and specifications have been properly understood and interpreted by the producers and suppliers.

The shop drawings should prove to the architect's satisfaction that the work of the contract would be fulfilled. If the shop drawings indicate that

the work depicted will not comply with the intent of the contract drawings and specifications, the architect has an opportunity to notify the contractor before the costs of fabrication, purchase, or installation have been incurred.”

The Administrator should employ the following procedure for the processing of all shop drawings and related product data relating to the project:

1. Shop drawings are required to be submitted in the format required by the Contract Documents. Shop drawing received in any other format may be returned to the Contractor with a “Not Reviewed” note attached to the submittal.
2. Shop drawing shall be initially reviewed by the Contractor and stamped accordingly. Shop drawings which do not bear the contractor's approval stamp may be returned to the Contractor to be resubmitted as required. Additionally, shop drawings containing excessive errors and/or that clearly indicate that the Contractor's review was inadequate.
3. Submittals are to be date stamped upon receipt and stamped with the standard office review stamp directly below the date stamp.
4. The Standard AIA G-712 Shop Drawing Review form is to be used for Submittals. A separate sheet shall be used for each specification division. Log submittals are to be by CSI number and number chronologically.
5. Shop drawing submittals shall be as required by the Contract Documents. All transmittals to Administrator and consultants shall be recorded in the Shop Drawing Log in the same manner as those submittals reviewed by the Owner and/or Architect. The shop drawing number should be written in the upper corner of the transmittal for ease in tracking.
6. The Architect's shop drawing review shall be conducted using a printed copy of the submittal. All correct items and deficient items needing correction are to be marked preferably using different colored markers. All questions during review process need to be noted.
7. The corrected drawing with appropriate review comments, date stamp, and approval stamp with necessary action indicated shall be transmitted back to the Contractor. The return submittal shall be recorded in the Shop Drawing Log with a submittal number, date, and status of transmitted item recorded. If the submittal is rejected, this should be noted.
8. Marked-up copies of the submittals should be retained for reference. It is suggested that the copies be marked accordingly (e.g., “mark-up,” “Final,” “Rejected,” etc.).

Once approved, the shop drawings should be distributed to the relevant parties including the Administrator, Owner, General Contractor, and

Architect of Record. Often steps have to be taken in the shop drawing review process to avoid any unnecessary work or assumption of responsibility by the Administrator, such as:

- Avoid accepting responsibility for such things as verifying field dimensions, confirming compatibility with other submitted items etc., as this work is clearly described in the Contract Documents as the responsibility of the General Contractor.
- Normally shop drawings are processed within (10) 10 working days. The Contractor should be advised in writing if the review for a particular submittal is anticipated to take longer than this.
- Shop drawings and project samples should be kept in a file cabinet at the Administrator's desk and not in the central file system.
- When the shop drawings for specialized equipment are furnished by the fabricator, it would be prudent to take the following precautions:
 - The Administrator's responsibilities should be carefully reviewed as they relate to the shop drawing.
 - Statements in the Owner/Architect agreement that may relieve the Architect of responsibility of design and construction work by others should not be solely relied upon.
 - It is advisable to consider bringing in a specialist (engineer) to design and approve the equipment if it presents unusual risks, not a fabricator. The specialist review should be requested prior to approving the equipment.
 - Consider having design and construction details checked by a qualified specialist if they are outside the Administrator's expertise.

Freedom of Information Letters (FOIL's)

The Freedom of Information Law (FOIL) allows the general public access to records maintained by the government. FOIL requests are often used as a means with which to check each subject property for building and code compliance, as well as locate its CO. The Research Log provides space in which to keep track of the numerous agencies and officials that are invariably contacted to try and locate the municipal departments that record and maintain such information. It is necessary to submit these "Foil" requests as soon as possible since most agencies, under the Freedom of Information Act, are usually given anywhere from 7 to 10 business days to respond. The information found on Foil requests is typically listed by agency, state, municipality, and then building or fire department. Responses to these requests are to be used as exhibits in the PSR. Note that some states such as Virginia

stipulate that they are not required to provide such information, even under Freedom of Information statutes, if the person or entity making the request is located outside of the state. In such instances the Administrator should be notified immediately.



4.8 QUALITY CONTROL AND QUALITY ASSURANCE

Although quality control and quality assurance are important concepts, many project managers and design professionals lack a deep understanding of their meanings and the differences between them. In fact, both these terms are often used interchangeably to refer to ways of ensuring the quality of a service or product. However, the terms are different in both meaning and in purpose. The ISO 9000 defines quality control as “the operational techniques and activities that are used to fulfill requirements for quality,” whereas its definition of quality assurance is “all those planned and systematic activities implemented to provide adequate confidence that an entity will fulfill requirements for quality.” This means that quality control refers to quality-related activities associated with the creation of project deliverables. Quality control is used to verify that deliverables are of acceptable quality and that they are complete and correct. Quality assurance on the other hand refers to the process used to create the deliverables, and can be performed by a manager, client, or third-party reviewer.

Quality assurance is based on a process approach. Quality monitoring and its assurance ensure that the processes and systems are developed and adhered in a manner that the deliverables are of superior (or at least acceptable) quality. This process is intended to produce defect-free goods or services with basically minimum or no rework required. Quality control, however, is product-based approach. It checks whether the deliverables satisfy specific quality requirements as well as the specifications of the customers or not. Should the results prove negative, suitable corrective action is taken by quality control personnel to rectify the situation. Another major difference between quality control and quality assurance is that assurance of quality is generally done before starting a project, whereas the quality control generally begins once the product has been manufactured. During the monitoring process, the requirements of the customers are defined and based on those requirements the processes and systems are established and documented. After manufacturing the product, the quality control process typically begins. Based on the client requirements and standards developed during the quality guarantee process, the quality control personnel check

whether the manufactured product satisfies those requirements or not. Assurance of quality is therefore a proactive or preventive process to avoid defects, whereas quality control is a corrective process to identify the defects in order to correct them.

The majority of activities falling under the scope of quality assurance are conducted by managers, clients, and third party auditors. Such activities may include process documentation, developing checklists, establishing standards, and conducting internal and external audits. Designers, Engineers, inspectors, and supervisors on the shop floor or project sight perform quality control activities. Quality control activities are varied and include performing and receiving inspection, final inspection, and other activities.

Quality control and quality assurance are both to a great extent interdependent. The quality assurance department relies predominantly on the feedback provided by the quality control department. For example, should a recurrent problem occur regarding the quality of the products, then the quality control department provides necessary feedback to the quality monitoring and assurance personnel that there is a problem in the process or system that is causing product quality issues. Upon determining the principal cause of the problem, the quality assurance department then instigates changes to the process to rectify the situation and to ensure that there are no quality issues to worry about in the future. Similarly, the quality control department follows the guidelines and standards established by quality assurance department to check and ensure that deliverables meet the quality requirements. For this reason, both departments are fundamental to maintaining the high quality of deliverables. And although both quality control and quality assurance are different processes, the strong interdependence between them can sometimes leads to confusion among design professionals and contractors.



Building Information Modeling (BIM)



5.1 WHAT IS BUILDING INFORMATION MODELING—BRIEF HISTORY AND OVERVIEW

Gone are the days when architects, engineers, and contractors typically operated independently of one another, offloading their portion of the project to those next in line. This may be because for over two decades, it has been recognized that early collaboration using virtual information models between all actors in a building project can reduce risks, construction timelines, and overall project costs. Indeed, Building Information Modeling (BIM) is one of the most promising developments in the architecture, engineering, and construction fields for many years. It has changed the way contractors and engineers do business, but while its application is still relatively new, and there is still much to learn, great strides have been made.

BIM was introduced nearly two decades ago mainly to distinguish the information-rich architectural 3D modeling from the traditional 2D drawing. It is being acclaimed by its advocates as a lifesaver for complicated projects because of its ability to correct errors early in the design stage and accurately schedule construction. Although over recent years, the term “Building Information Modeling” or “BIM” has gained widespread popularity, it has failed to gain a widespread consistent definition. According to Patrick Suermann, PE, NBIMS Testing Team Leader, “BIM is the virtual representation of the physical and functional characteristics of a facility from inception onward. As such, it serves as a shared information repository for collaboration throughout a facility’s lifecycle.” The NIBS (National Institute of Building Sciences) sees it as “a digital representation of physical and functional characteristics of a facility...and a shared knowledge resource for information about a facility forming a reliable basis for decisions during its life-cycle; defined as existing from earliest conception to demolition.” But generally speaking, BIM technology allows an accurate virtual model of a building to be constructed digitally. Completed computer-generated models contain accurate and well-defined geometry and pertinent data required

to facilitate the construction, fabrication, and procurement activities necessary to realize the final building.

BIM thus consists mainly of 3D modeling concepts, in addition to information database technology, and interoperable software in a desktop computer environment that architects, engineers, and contractors can use to design a facility and simulate construction. This technology allows members of the project team to generate a virtual model of the structure and all of its systems in 3D and to be able to share that information with the entire project team. Likewise, the drawings, specifications, and construction details are fundamental to the model, which includes attributes such as building geometry, spatial relationships, quantity characteristics of building components, and geographic information. This allows the project team to quickly identify design and construction issues and resolve them in a virtual environment well before the construction phase in the real world.

BIM is therefore, primarily a process by which you generate and manage building data during a project's life cycle. BIM typically uses three-dimensional, real-time, dynamic building modeling software to manage and increase productivity in building design and construction. The process produces the Building Information Model, which encompasses all relevant data relating to building geometry, spatial relationships, geographic information, and quantities and properties of building components. The construction technology for the BIM process is continuing to improve with the passing of time, as contractors, architects, engineers, and others continue to find new ways to improve the process. One of the many significant advantages of using modern BIM design tools is as Chuck Eastman, Director, Digital Building Laboratory, states, they now "define objects parametrically. That is, the objects are defined as parameters and relations to other objects, so that if a related object changes, this one will also. Parametric objects automatically re-build themselves according to the rules embedded in them. The rules may be simple, requiring a window to be wholly within a wall, and moving the window with the wall, or complex defining size ranges, and detailing, such as the physical connection between a steel beam and column."

But before one can give a precise definition of BIM, one must resolve the ambiguity over whether BIM is or is not fundamentally different from CAD. In the author's opinion, BIM is not CAD, nor is it intended to be CAD. CAD is a replacement for pen and paper, a documentation tool, and CAD files are basic data. It consists of elements that are lines, arcs, and circles—and sometimes surfaces and solids, which are purely graphical representations of building components. Moreover, early definitions

asserting that BIM is basically a 3D model of a facility are incorrect and do not reflect the truth, nor do they adequately communicate the capabilities and potential of digital, object-based, interoperable BIM processes and tools and modern communications techniques. BIM programs today are design applications in which the documentation flows from and is a derivative of the process, from schematic design to construction to facility management. Furthermore, with BIM technology, an accurate virtual model of a building can be constructed digitally, and when completed, the computer-generated model will contain all the relevant data and accurate geometry needed to support the construction, fabrication, and procurement activities required to execute the project.

Kenneth Stowe, PE, a construction technology expert and development strategist at Autodesk, Inc. reaffirms this and comments, “The construction industry is in the early stages of an historic transformation: from a 2D environment to a model-based environment. The benefits are many and are enjoyed by various members of the project team. Some firms are leading in *planning and directing the whole team in BIM participation*, implementing best practices, and making a point of measuring those benefits. The savings can be in the millions of dollars. The project durations are being reduced by weeks or months.”

It is sometimes difficult to determine who first coined the term BIM. Some claim that Charles M. Eastman at Georgia Tech coined the term BIM, the theory being based on a view that the term BIM “Building Information Model” is basically the same as “Building Product Model,” which Eastman has used extensively in his book and papers since the late 1970s. Other writers believe it was first coined by architect and Autodesk building industry strategist Phil Bernstein, FAIA, who reportedly first used the actual term BIM “building information modeling,” which was later accepted by Bentley and others (see [Fig. 5.1](#)). It is claimed that Graphisoft produces the original BIM—in the original terminology Virtual Building—software, known as Archicad. But many firms and organizations made contributions to BIM’s continuing development. For example, Skidmore, Owings & Merrill, LLC (SOM) is one such pioneering firm which made significant contributions to the development and use of BIM.

Early on, SOM created a multipurpose, database-driven, modeling system known as AES, or Architecture Engineering System, and single-handedly pioneered its development. AES is regarded by some as the precursor to today’s BIM tools. Indeed, in the future, SOM “envisions BIM as a vehicle for real-time performative design simulation and environmental analysis,

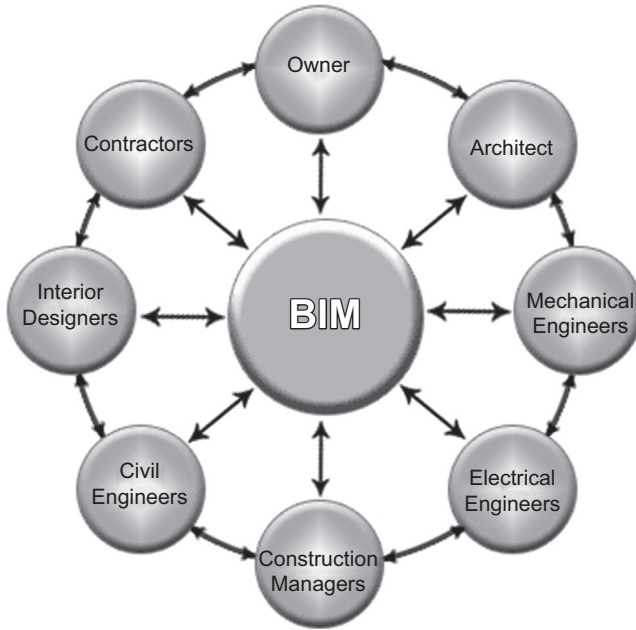

Figure 5.1 Diagram showing the relationship of BIM to the various stakeholders and project team members. BIM technology continues to manifest itself as the most feasible and reliable option in the building construction industry. BIM can minimize errors and omissions made by the project team by allowing the use of conflict detection technology where the computer informs team members whenever parts of the building are clashing or in conflict. *Source: ADVENSER Engineering Services Private Ltd.*

enabled through new visual and tactile feedback systems. This will allow architects to focus on building performance that can truly be validated—obtaining and interpreting data as one simultaneously designs—and will encompass new modes of collaboration. SOM envisions the architect/engineer in a pivotal role in this new virtual design and construction collaborative environment: as the conceiver of ideas and the manager of knowledge.”

Dana (Deke) Smith, FAIA, Executive Director buildingSMART alliance and who has been involved with the development of BIM since its inception, says that, “One of the basic principles and metrics for BIM implementation is the ability to enter data one time and then use it many times throughout the life of the project.” Smith identifies the 10 principles of BIM as:

1. Coordinate and plan with all parties before you start
2. Ensure all parties have life cycle view—involve them early and often
3. Build the model, then build to the model

4. Detailed data can be summarized (The reverse is not possible)
5. Enter data one time then improve and refine over life
6. Build data sustainment into business process—keep data alive
7. Use information assurance and metadata to build trust—know data sources and users
8. Contract for data—good contracts make good projects
9. Ensure data are externally accessible yet protected
10. Use international standards and cloud storage to ensure long-term accessibility

Smith believes that, “We are still all too often slaves to the stovepipes that have been our industry’s tradition, where information is collected for a specific instance and then not reused by others. There are currently many reasons for this: perceived intellectual property concerns, perceived liability issues, organizations pushing their own agenda, proprietary approaches, and simply not knowing that someone already entered the information because of poor ability to collaborate.

One group taking this challenge head-on is buildingSMART International. buildingSMART International is a coalition of more than 50 countries worldwide which are focused on implementing an open standard, BIM approach to interoperability of information for building construction and facility maintenance. The North American chapter of this group is the buildingSMART alliance. While it is our belief that the final goal will be an international, standards-based, information exchange, the primary goal of interoperability remains at the foundation of this effort, using whatever format is universally easiest to use at the time.”

BIM software has proven to be a very promising tool that allows architects and engineers to digitally model the different elements of a building (shape, structure, heating/cooling, cost, materials etc.) in real-time and quickly understand how specific changes in design or construction models will impact other variables like structure, loads, energy efficiency, and the fiscal bottom line. BIM has especially helped to enable sustainable design—allowing architects and engineers access to higher tech tools than ever before to carefully integrate and analyze things such as, heat gain, solar, ventilation, and energy efficiency in their designs (Fig. 5.2).

Today, we have several organizations that have initiatives underway to develop a National BIM Standard. In December 2007, the first version of the National BIM Standard (NBIMS Version 1) which was written by a team of 30 subject matter experts was passed, and which primarily established



Figure 5.2 Miami Science Museum—using BIM for Green Building which was designed by Grimshaw Architects, MiaSci won a grant from the US Department of Energy in 2009 to incorporate BIM into the design process to explore different environmental issues during the design stage and to ultimately produce a greener building.

the approach for developing open BIM standards. However, it has failed to take hold in the architecture, engineering, and construction (AEC) community mostly because of its reliance on the Industry Foundation Class (IFC) file format for 3D modeling. After several years, the National Institute of Building Sciences buildingSMART Alliance developed Version 2 of the National BIM Standard–United States (NBIMS-US) which is a significant improvement on Version 1. On July 2015, the National Institute of Building Sciences buildingSMART alliance released the latest edition of the nation’s consensus-based standard governing BIM. The NBIMS-US Version 3 (V3) covers the full life cycle of buildings from planning and design through construction and operations. The United Kingdom has also recently come out with its own AEC (UK) BIM Standards. Moreover, the adoption of BIM is now mandated in the United Kingdom from 2016.

BIM processes are helping countless firms in diverse industries to operate more productively, to produce higher quality work, to attract better talent, and to attract new business. And today, multiple federal agencies are implementing BIM initiatives, from GSA and Army Corps of Engineers to the US Coast Guard and Sandia National Laboratories. Finith Jernigan, AIA, President of Design Atlantic, Ltd says, “To prosper in today’s fast changing and unpredictable markets, you need new ways of doing business more

effectively.” And although BIM is not a technology, it does require appropriate technology to be implemented effectively. It is therefore almost certain that all governmental or public infrastructure bid requirements will now include use of BIM. This trend is similar in the private sector.



5.2 BASIC BENEFITS AND CHALLENGES/RISKS OF USING BUILDING INFORMATION MODELING

According to Sam Neider, director and cofounder, Proactive Controls Group, Pittsburgh, PA, “BIM allows the reduction of risk through better information throughout the process. So when you look at a project, not only are you gaining efficiencies via clash detection, coordination, scheduling, etc., you are also reducing owner’s risk of exposure for schedule and budget overruns, for claims, etc. Looking at the current economy, owners that would put down big dollars to do a project are no longer doing so. So what will help convince them to do so? You need to convince them there is a much better risk scenario out there and that is what BIM (and IPD) is delivering.”

The rapid embracing of BIM is fundamentally changing the way AEC project teams work together to communicate, resolve problems, and build efficient projects faster and at less cost. In today’s highly competitive construction market, it is no longer sufficient to execute a project in the real world of concrete, girders, sheet metal, pipe, and racks. In many cases, requests for proposals (RFPs) on most large projects now require contractors and subcontractors to execute the project first in the virtual world using BIM, and understandably so.

5.2.1 Benefits of Using Building Information Modeling

Effective use of BIM can have a dramatic impact on a project through improved design, enhanced constructability, and quicker project completion, saving time and money, both for the owner as well as the project team. BIM is also emerging as the solution to reduce waste and inefficiency in building design and construction, although some organizations are taking a wait-and-see approach regarding BIM, seeking clear evidence for return on the investment that it would entail.

The most significant benefits of BIM include the following:

- Lower net costs and risks for owners, designers, and engineers
- Development of a schematic model prior to the generation of a detailed building model allows the designer to make a more accurate assessment

of the proposed scheme and evaluate whether it meets the functional and sustainable requirements set out by the owner, thus helping increase project performance and overall quality (Fig. 5.3)

- Improved productivity due to easy retrieval of information
- Improved coordination of construction documents
- Coordination of the construction reduces construction time and eliminates change orders
- Contractor and Subcontractors' costs and risks are reduced
- BIM allows accurate and consistent 2D drawings to be generated at any stage of the design. This in turn reduces the amount of time needed to produce construction drawings for the different design disciplines while minimizing the number of potential errors in the construction drawings process
- Increased speed of project delivery
- Embedding and linking of vital information such as vendors for specific materials, location of details, and quantities required for estimation and tendering

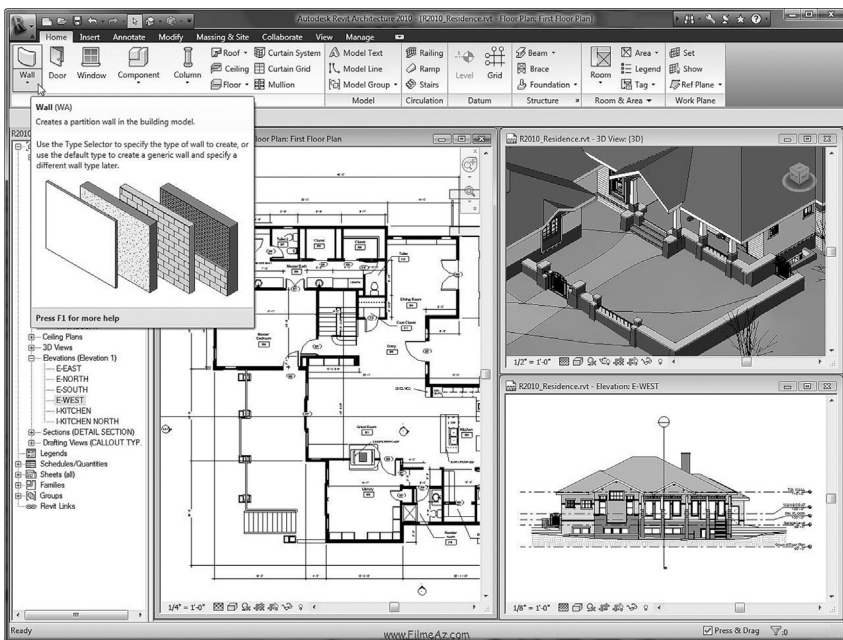

Figure 5.3 Diagram showing use of Autodesk Building Information Modeling (BIM) solutions to achieve better design results. According to Autodesk, “BIM helps improve the way work gets done by providing more insight and greater predictability.”

- BIM allows the project team and owner to visualize the design at any stage of the process with the understanding that it will be dimensionally consistent in every view, thereby improving monitoring efficiency and reducing operating costs
- Realtors, appraisers, and bankers save money
- BIM technology will generally facilitate coordination and collaboration by multiple design disciplines. This shortens the design period, while helping to reduce potential design errors and omissions. It also affords greater insight and early detection of possible design problems, thereby allowing for better performance prediction
- First responders can make buildings safer

Kenneth H. Stowe, PE, on the other hand says, “There are ten measurable ways for project teams to benefit from a comprehensive BIM solution. They fall into two categories—each with five ways to leverage BIM.” According to Stowe, these are:

Better Planning, Cost Forecasting, and Control

- Model-to-Cost integration means that more design options can be quickly and accurately priced for capital cost and compared to building performance gains.
- 3D Visualization invites richer participation resulting in fewer RFI's and Change Orders.
- 3D Coordination for the subcontractors means clash-free geometry in the field, reducing rework.
- 4D construction simulation and communications heightens the power of planning for safety and field efficiency.
- 3D geometry fosters confidence in Prefabrication enabling higher quality, lower labor costs, and accelerated schedules.

Lean Project Teamwork and Communications

- The ability to affordably simulate building performance leads to better decisions for structure, comfort, lighting, energy performance, resource conservation, materials performance
- Coordinated documents in a lean and automated, dramatically reducing wasted effort and rework, and fostering confidence in the specialty trades
- Rich digital teamwork leads to early builder and owner guidance for more constructible designs and efficiencies during maintenance
- Confidence in the geometry enables Just-in-Time deliveries, leading to safer and well-orchestrated field work

- Stability in the design configuration leads to labor productivity improvements, leading directly to high performing construction

More information and analysis including a list of the benefits of BIM, can be found by going online and visiting sites like Wikipedia or Autodesk at:

https://en.wikipedia.org/wiki/Building_information_modeling or <http://www.autodesk.com/solutions/bim/overviewor>

It should be noted that each member of the project team may have a different concept of what is considered to be the most beneficial aspect of BIM. Thus, BIM Wiki, for example, breaks down these benefits to specific groups and then goes into greater detail, for each group as follows:

1. Benefits at Planning
 - 1.1. Benefits to the Planner/Designer
 - 1.2. Benefits to the Cost Engineer
 - 1.3. Benefits to the Owner
2. Benefits at Design
 - 2.1. Benefits to the Architectural Designer
 - 2.2. Benefits to the Electrical Designer
 - 2.3. Benefits to the Mechanical Designer
 - 2.4. Benefits to the Plumbing Designer
 - 2.5. Benefits to the Landscape Designer
 - 2.6. Benefits to the Structural Designer
 - 2.7. Benefits to the Telecom Designer
 - 2.8. Benefits to the Civil Engineering Designer
 - 2.9. Benefits to the Cost Engineer
 - 2.10. Benefits to the Specifications Writer
 - 2.11. Benefits to the Owner
3. Benefits at Construction
 - 3.1. Benefits to the Construction Manager
 - 3.2. Benefits to the Construction Contractor
 - 3.3. Benefits to the Owner
4. Benefits at Operations
 - 4.1. Benefits to the Occupant
 - 4.2. Benefits to the Owner
5. Benefits at Maintenance
 - 5.1. Benefits to the Occupant
 - 5.2. Benefits to the Owner

BIM Wiki then renders additional detail, for example, for the plumbing designer, the benefits are seen as:

- Fixture schedules can be synchronized or linked to the architects schedule with a mere key stroke if desired.

- Fixture schedules, plans, riser diagrams, sections, and details can be automatically synchronized.
- Designer and his/her collaborators can visualize fixture layout and piping in 3D throughout the design process.
- Collisions and interferences can be determined immediately and automatically by software and integrated designs. NO MORE RFIs to process, because BIM contains the information they need.
- Riser diagrams can be developed once and then automatically synchronized with the plans. All engineering data (such as drainage fixture units) can be automatically and continuously followed in plan and analyzed in a variety of views and filters.
- Revisions to the plan, including architecture, can be checked in much less time compared to CAD or drafting methods.
- Designer can add, delete, and modify fixtures and outlets easily with automatic update to the engineering data and the model.

The US National Institute of Standards and Technology (NIST) issued a report in August 2004 entitled “Cost Analysis of Inadequate Interoperability in the U.S. Capital Facilities Industry” (NIST GCR 04-867); the NIST report concludes that, as a conservative estimate, \$15.8 billion is lost annually by the US capital facilities industry caused by inadequate interoperability due to “the highly fragmented nature of the industry, the industry’s continued paper-based business practices, a lack of standardization, and inconsistent technology adoption among stakeholders”.

Chris Rippingham, BIM engineer at San Francisco-based DPR Construction, says “Our thinking is that if we can sit at the table with the other great minds in the project—the architects, MEP and structural engineers, and our key subcontractors—as early as possible, then we can all deliver the most efficient building.” He goes on to say, “We definitely try to collaborate as much as possible even in situations where the contract doesn’t obligate us to do that, but with our experience in integrated delivery that’s our normal way of working.”

Integration and transition of models has led to increased cost effectiveness in employing BIM, and although the transition process may be long and expensive, the ultimate benefits of BIM are certainly worth the investment. When BIM is properly used, it coordinates the MEP trades, expands prefabrication opportunities, increases productivity, eliminates most rework, and reduces labor costs, while improving the consistency of the final work product. This is echoed by the EMCOR Group, Inc., headquartered in Norwalk, Connecticut, which considers it well worth the contractor’s time, effort, and financial investment to make the transition. EMCOR also emphasizes that successful implementation

and use of BIM requires significant investments in technology, staff, and training. EMCOR and its subsidiaries (such as Dynaletric) have considerable first-hand experience with this transition, having more than 200 trained professionals who are well versed in using BIM. And with increasing usage of BIM among trade contractors, combined with improved delivery methods, the building industry continues to move closer to realization of major BIM benefits—including substantial cost and savings of time.

BIM technology also gives apartment building owners, architects, engineers, contractors, and fabricators affordable access to a full range of interactive tools for refitting of buildings for enhanced energy conservation, thereby helping to “green” these buildings. MonsterCommercial.com, a commercial real estate information service, says that “Utilizing sophisticated parametric change technology, BIM software enables energy savings assessments for every conceivable aspect of a project – from floor plan designs to high-tech thermal imaging analysis.”

5.2.2 Risks Associated With Applying Building Information Modeling to Sustainable Projects

As mentioned earlier, the advent of BIM technology is having a tremendous impact on the construction industry while simultaneously making the overall design systems for construction projects more efficient. It is also rapidly becoming the dominant system for project design delivery. And while the use of BIM benefits far outweighs the negatives and has the potential to reduce risk, it is nevertheless imperative to have a total understanding of the impact of these challenges and risks on a project. Moreover, we find that BIM also begins to blur the allocations of responsibility developed over generations, to the extent that it has become necessary for all members of the project team (i.e., architects, engineers, contractors, owners, and developers) to adapt legal safeguards. It may take some time to fully comprehend the full scope of BIM’s legal ramifications and the sources of potential risk that are generated by utilizing BIM on a green project. Mike Bordenaro, Cofounder, BIM Education Co-op feels that “The biggest hindrance to achieving these benefits is the lack of Universal acceptance, support and implementation of Open Standards as represented by the work of the buildingSMART alliance.” The Alliance for Construction Excellence (ACE) and other organizations list some of the challenges that a project would face by employing BIM and collectively as a team determines how to address these challenges in the rapidly changing technology of today. Contract provisions dealing with potential risks that are unique to BIM should not be overlooked by the parties and should be addressed in their design–build/BIM

contracts. Perhaps, the most anticipated potential liabilities/risk challenges and questions that would confront a BIM project include the following:

- **Information Management:** The function of a BIM model includes the projection of values, cost savings and/or efficiencies, but what happens if when the building is completed, these projections fail to materialize?
- **Ownership of the model at various stages of the project.** Does the owner have sole ownership of the model after construction?
- **Copyright—**How should intellectual property rights be addressed? It is important to license and secure all intellectual property used within the model and to ensure that proprietary information or copyrighted information integrated into the BIM model is not a risk of copyright or patent infringement. Also, it should be predetermined who owns the data in the BIM model and who determines their use?
- **Control concerns:** To create BIM models requires coordination. Which party is responsible for this and who has access to the models and to what degree? Does the party managing the modeling process take on any additional liability exposure? There is often a concern that the Model may change without all stakeholders input.
- **Concern that design and construction fees do not support the BIM process (or training for BIM).**
- **The BIM process will be a complete paradigm shift for the design and construction industry.**
- **Legal/Insurance language and procedures will need future clarification.**
- **Level of detail from the design team and what level of accuracy and reliance is the information provided by the team to the BIM model?**
- **BIM modeling allows the design–build team to improve on the project’s potential aesthetics, but what happens when those projections do not meet expectations?**
- **Project-specific standards for file sharing and is there a recognized protocol for the preservation of different replications of the model for historical purposes as well as for possible conflict?**
- **2D documents are generated from the design model for permits and distributed to general contractor (GC) and subcontractors along with the 3D design model.**
- **Shop drawings and submittals may only be eliminated for subcontractors, vendor/suppliers participating in the development of the model. There will be others who have no need to access the model (i.e., toilet accessories, components, etc.).**
- **What happens when a BIM model is based on or includes faulty information provided by specialty equipment vendors?**

It is apparent from the above that with the advent of BIM technologies, methodologies, and processes, it is extremely important to identify who or what holds key project details: i.e., the Architect or the GC, the model or the drawings, because with that ownership, comes great reward or risk. Identifying these legal risks should assist the parties in addressing the unique challenges that are associated with the use of BIM, particularly since there are few standard form contracts currently on the market that adequately address BIM legal risks. It should be noted that contracts play a pivotal role in defining deliverables, interactions with project stakeholders, and risk obligations for commercial building projects. On June 30, 2008, ConsensusDOCS 301 BIM Addendum was released, which is described as a product of industry consensus of current best practices in the use of BIM techniques and technology. ConsensusDOCS contracts are continuously updated to keep pace with the latest changes in construction practices and legal updates. ConsensusDOCS contracts were developed by a coalition of 35 leading industry associations representing owners, contractors, subcontractors, designers, and sureties. Additionally, it is also the first contract form that is specifically applicable to projects using BIM and remains the only industry standard document (with the AIA documents) to adequately address the legal uncertainties associated with utilizing BIM. ConsensusDOCS contract document series include:

- 200 Series—General Contracting
- 300 Series—Collaborative
- 400 Series—Design-Build
- 500 Series—CM At-Risk
- 700 Series—Subcontracting
- 800 Series—Program Management

But while the BIM Addendum reflects a good starting point, it is nevertheless an addendum designed to be used with other traditional standard form contracts and preferably should not be used as a stand-alone contract. And as with any addendum the parties should carefully review underlying agreements and address any inconsistencies that may exist between the addendum and the base contract documents.

Project stakeholders should be made aware that there is apparently no case law that currently addresses BIM legal risks, as there is no case law that tests the adequacy of the BIM Addendum. However, for project participants to be in a better position to avoid potential conflict, they examine the unique potential BIM risks of their project and address these risks upfront.



5.3 INTEGRATED PROJECT DELIVERY—SHARING INTELLIGENT DATA FOR SUSTAINABLE SOLUTIONS

The type of communication that should take place should be discussed among the various parties involved in a project and how data sharing should be approached. Advantage should be taken of the three-dimensional information, such as that provided by BIM, which allows all members of the Building Team to visualize the many components of a project and to determine how they will work together. BIM and other 3D tools convey the idea and intent of the designer to the entire Building Team and lay the groundwork for integrated project delivery (IPD).

IPD is a recently adopted innovative approach to the design and construction of buildings. Charles Thomsen, FAIA, FCMAA (fellow, American Institute of Architects/fellow, Construction Management Association of America), a leading expert in this field, defines it thus: “Integrated project delivery is an approach to agreements and processes for design and construction, conceived to accommodate the intense intellectual collaboration that 21st century complex buildings require.” At the core of IPD is the capability to have all data that affect a project to be stored in one unified database.

Thomsen says IPD projects can generally be characterized by eight common themes, which include the following:

- A legal relationship
- A management committee
- An incentive pool
- A no-blame working environment
- Design assistance
- Collaboration software
- Lean construction
- Integrated leadership

The main objective of IPD is to promote maximum collaboration, open sharing of project goals and risks, and maximizes the knowledge and insights of all participants (Fig. 5.4). The end result of this process being an increase in value to the owner, and a reduction in waste and inefficiencies as well as increased productivity throughout the various phases of design, fabrication, and construction of the project. When IPD teams are first formed, they are typically faced with the challenge of determining how they will organize themselves to enable themselves to collaborate

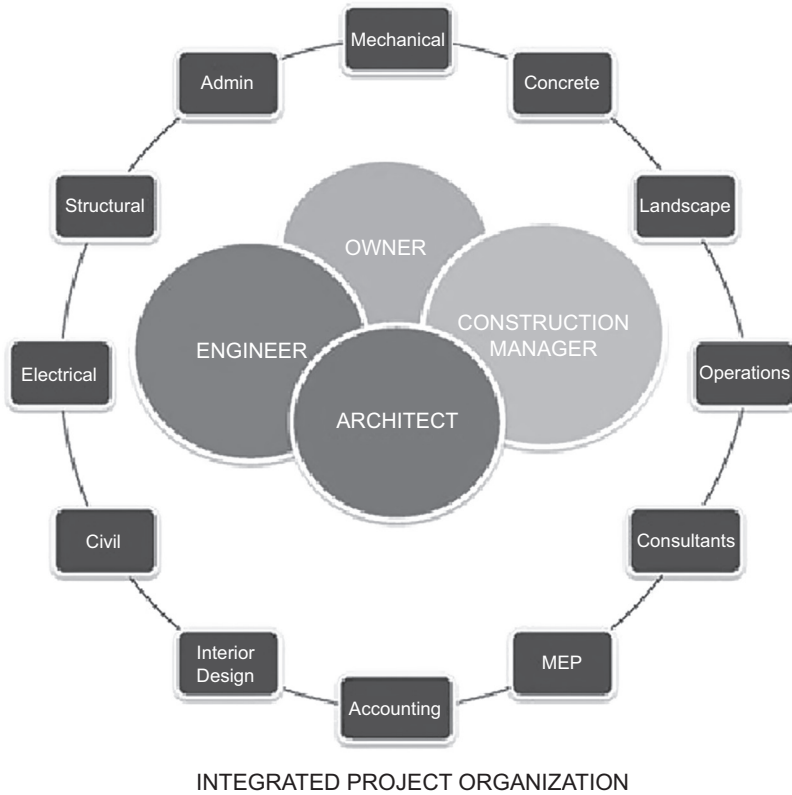

Figure 5.4 Diagram showing integrated project organization.

effectively, and what processes they should follow, and in what sequence. Previously, sequential exchange of paper-based documentation was the main information-sharing method between project participants for the vast majority of design and construction projects. By challenging traditional methods of delivery, IPD has paved the way for improved, faster, and less costly building projects in addition to streamlined information and material supply chains, and more efficient processes throughout the building design and construction industry.

While the sequential exchange method has worked typically well in most idealized project situations, particularly where there is adequate time to fully develop the design intent, evaluate it, and then modify it as often as necessary prior to fabrication and installation, in complex project situations, owners and their project design and construction teams find themselves having to work in parallel and with incomplete information.

The fundamental essence of IPD revolves around the concept of having all stakeholders involved on a project working together as early as possible—preferably during schematic design—to accumulate, combine, and focus the expertise of the parties toward the development of a project prior to anything being designed. Furthermore, as an inducement to the parties, shared risk and shared reward contracts are established upfront with the clear understanding that all parties must work together for the good of the project.

An IPD Guide was developed jointly by the AIA's Documents Committee and the AIA California Council, as a tool to assist owners, architects, engineers, contractors and other key stakeholders, to move toward unified models and improved design, construction, and operations processes.

From the above, it is clear that BIM and IPD have changed the way we hire and mentor, in addition to rethinking our approach to handling data requirements. Here the underlying principle that needs to be remembered is the realization that adopting BIM and IPD workflows means improved communication both internally within the organization and externally with clients and trade partners.



5.4 BUILDING FORM WITH BUILDING INFORMATION MODELING

BIM transcends beyond traditional 2D drawings to include the additional dimensions of height and time. And because BIM allows active material input in the model, (including data required for LEED credits), any proposed changes can quickly be analyzed to confirm that these changes do not adversely impact the project's objectives (Fig. 5.5). Likewise, by providing a long-term repository warehouse for data-representing design intent, LEED and green documentation are much less likely to be deleted or overlooked in the BIM model. Moreover, BIM allows architects, engineers, and contractors to weigh the costs and benefits of the majority of building components and their interrelationships. Also, the affirmation of the design options by the BIM model facilitates the reduction of design contingencies and allows the construction schedule to be consolidated. The provision of more accurate scheduling and improved cost take-offs, reduce the risk and construction contingencies thus allowing the owner the potential to incorporate even more green features that may not have initially fitted the project's cost model. BIM also allows architects, engineers, and contractors the luxury of importing/exporting data from a wide variety of related software with ease,

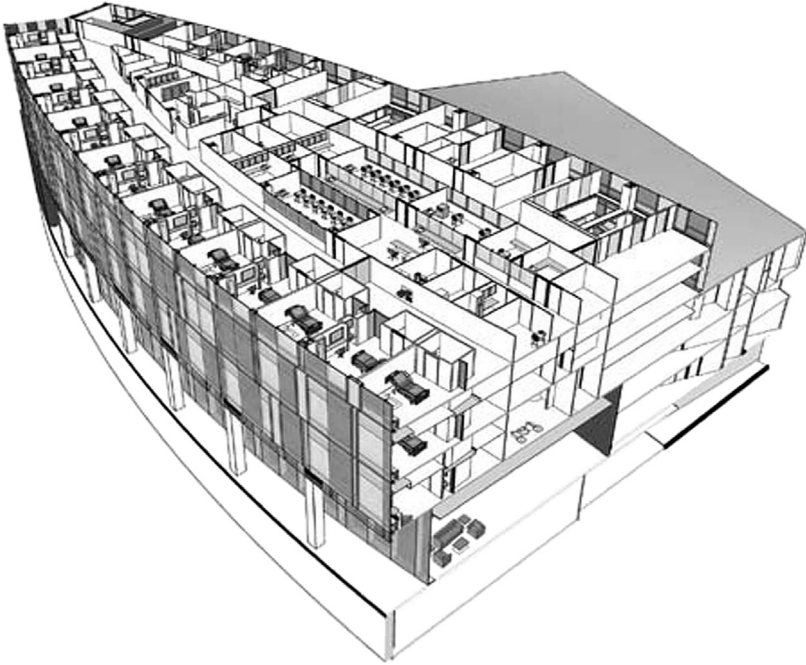

Figure 5.5 Use of BIM to “green an apartment building.” *Source: Monster Commercial.*

thereby simplifying design coordination and reducing the potential for loss of green goals in the transcription between software and individual users. The employment of BIM from the outset can help reduce green design fees partly because the data embedded in the model reduces multiple inputting processes, and any design modifications are immediately reflected. Such design variations might typically have resulted in a change order whereas now they may be checked quickly and with minimal effort to determine their impact on the project. There are clear signals that the industry is irreversibly headed in these new directions. It is worthwhile noting that up to 20 LEED credits can be validated and documented by using BIM.

5.4.1 Customizing Building Information Modeling

There is a saying that necessity is the mother of invention, and this would definitely apply to BIM in the contracting industry. Much of BIM’s development has been focused largely toward serving the needs of architectural and engineering firms. One of the key advantages of applying BIM systems is its flexibility and allowing project participants to customize existing

elements, or create new elements, which can then be incorporated into the design. Indeed, customization can usually provide great benefits in the use of BIM software. However, it has been shown that a number of firms that are using BIM technology are not reaping the greatest benefits due to some difficulties such as the lack of communication between the various participants in the design and the construction. To address such issues, it is strongly recommended to bring on board a new professional with a special role specializing in the application of BIM technology, standards, and modeling and who would also undertake the coordination needed in BIM contexts. Such a *BIM Manager* (the precise title of such a specialist is immaterial) would be an integral part of the project team and would be a small investment compared to the potential benefits. Many AEC sector companies are already employing BIM Managers although their precise function and responsibilities frequently require defining. This is particularly important because to this day, software vendors have yet to build a BIM product that comes out of the box with content that totally meets the requirements of the various industry contractors and fabricators.

Over the course of several years, Dynaletric, an electrical subcontractor and an EMCOR Company, is an industry leader in BIM applications. And through the implementation of Virtual Design and Construction (VDC), Dynaletric has been able to develop and execute electrical services and systems. To achieve this, a layer standard had to be determined and keyed—e.g., a layer for conduit, a layer for hangers, etc., which allowed the system to be designed to automatically place each component type on the appropriate layer. These latest efforts include embedding calculations into the BIM which are aimed at improving prefabrication and to make the project team more efficient allowing it to achieve schedule and cost savings while making the overall project more efficient. As a result of all this in-house customization (doing everything from schedules and take-offs to automatic engineering calculations), when a BIM engineer models an electrical system on a project, it will be very accurate indeed.

5.4.2 Making the Transformation

As previously discussed, successful implementation and utilization of BIM requires significant investments in technology, staff, and training. There is no “magic wand” solution, which is why in adopting the process, one’s eyes should be wide open. Furthermore, upon taking the decision to transition to BIM, careful consideration should be given to the purchase of BIM software, which should be carefully evaluated. Once the goals and priorities

are analyzed and determined, one can proceed forward, bearing in mind that any transition from CAD to the new BIM technology will require additional investment for among other things, to purchase more powerful PC hardware, software, servers, as well as high-speed telecommunications to support the process. It will then also require additional investment to customize the application software.

The transition to BIM will also require the hiring of a specialist BIM Manager—someone with a solid foundation of BIM technology and computer skills, and who understands the process of collaboration, in addition to possessing the technical and intellectual capabilities to integrate this knowledge into the BIM model. The figure shown as Fig. 5.6 was almost unanimously selected by the jury as the winner in the category Design/Delivery Process Innovation using BIM, and it has a LEED Gold certification. M.A. Mortenson Company was committed to using BIM in all aspects of the Hall project and created the role of design coordinator to manage coordination, interdisciplinary model creation, and interoperability.

BIM is frequently associated with Industry Foundation Classes (IFCs) and aecXML, which are data structures for representing information it uses. IFCs are described as object-based file formats with a data model developed in BIM by buildingSMART of the International Alliance for Interoperability (IAI) to facilitate interoperability between software platforms in the building industry. However, aecXML is a specific XML mark-up language that typically employs IFCs to create a vendor-neutral means to access data generated by BIM. It was developed for use mainly in the AEC and facility management industries, in conjunction with BIM software. There are also other data structures on the market, but most of these are proprietary.

In addition to BIM technology being used for new construction, there are continuing attempts at creating BIM software that can be applied for older, preexisting facilities. For this, they typically reference key metrics such as the Facility Condition Index (FCI). The FCI is essentially used in Facilities Management to provide a benchmark to compare the relative condition of a group of facilities. However, to validate the accuracy of these models, they require being monitored over time, because whenever an attempt is made to model an existing building, numerous assumptions must be made regarding data relating to materials, design standards, building codes, construction methods, and the like. This makes it far more difficult and complex to modify an information model of an existing building from the design stage.

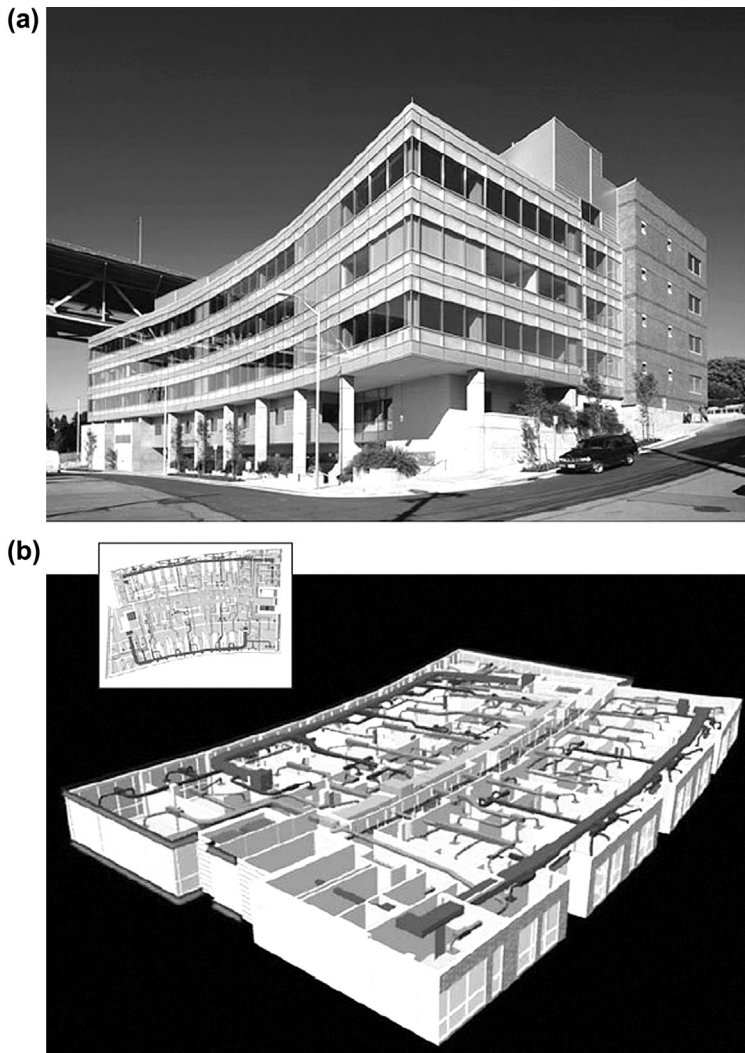

Figure 5.6 (a)The full 3D model of a building and (b) the mechanical systems layout model that allowed the Benjamin D. Hall Interdisciplinary Research Building to be designed with an extra floor. Source: www.mortenson.com/Resources/Images/11321.pdf.



5.5 BUILDING SYSTEMS WITH BUILDING INFORMATION MODELING

A BIM Modeler can easily extract intelligent property data from a BIM model for the purposes of engineering, prefabrication, and take-off. However, this was not possible in off-the-shelf software; Dynalectric had to customize its BIM system to enable its staff to perform these functions. In addition, Dynalectric has in place a 4000+ object library that contains custom objects intelligently linked together to both populate the model as well as to derive information from it, including scheduling, seismic calculations, and so forth. The benefits of customized BIM software are many, including annotating drawings and creating schedules. For example, by merely employing pertinent intelligent property data to conduit and parts, the BIM modeler or staff can easily get a take-off of the conduit to determine the number of linear feet or quantity of hangers. In this way, it is possible to annotate conduit elevations by simply pulling up live data from the actual model components in the drawing.

Moreover, customization has enabled the BIM modeler and the project team to easily perform engineering calculations without hesitation. Likewise, a set of routines can be easily be formulated that would work within the intelligent property data to calculate strut loads, and which is capable of recalculating automatically as the user changes the length of the object. This system in turn, enables the BIM modeler and the project team to perform live engineering calculations including “what-if” scenarios, quickly and accurately.

5.5.1 Virtual Best Practices

Over the last decade, we have witnessed BIM technologies emerge from the research and development (R&D) arena and enter the main stream of green construction. And it must be apparent from this that BIM has become much more than an electronic drawing tool, allowing project participants and stakeholders full collaboration. Generally, the BIM Manager (or the GC) is responsible for designing and implementing the BIM execution plan. This will vary from project to project but includes determining what is to be modeled and at what level of detail, as well as facilitating mechanical, electrical, and plumbing (MEP) coordination.

However, in today’s BIM technology world, each trade is given architectural and structural models from the owner. The trades then commence

routing their systems. The use of Design BIM systems facilitates detection of internal conflicts, and the employment of model viewing systems such as NavisWorks, offers the ability to detect and highlight conflicts between the models and other information imported into the viewer. Each trade contractor would then post regularly, say, on a weekly basis its systems to an FTP or other shared website. The BIM Manager (or GC) can then assemble all of the models into a composite using say, NavisWorks, which enables project team members to integrate and share data and drawings from the various software programs. The composite BIM can be viewed, manipulated, modified, and analyzed for conflicts among the trades and then hammer out modifications to resolve the conflicts. This process continues throughout the project—floor by floor and quadrant by quadrant until all the conflicts are finally resolved and “fit” in the virtual building. This integration of key systems into the model BIM can greatly reduce conflict issues.

The continuous development of BIM will mean greater and improved opportunities to owners, architects, engineers, constructors, and manufacturers who will be able to model reality in the built environment with greater accuracy and reliability, particularly with the use of plug-ins, network (BIM) servers brought online, the availability of enhanced third-party interface and analysis tools able to function with major BIM software packages, and local hardware with increased capacity to handle, store, and manipulate larger files on a cost-effective basis. This combining of the most advanced virtual reality modeling technology in computer science and applying the most current business process in the construction industry, the BIM technology world is progressing so rapidly that much of the published data may already be out of date.

5.5.2 AIA Document E202

Because BIM is a relatively new technology, there were some legal challenges and other issues that necessitated clarification. To help clear up these legal issues with BIM, the AIA recently released document E202, which lays out standard procedures and responsibilities for BIM models, but most importantly, it serves as a standard contract for projects using BIM. This document also establishes certain rules and regulations such as who owns the model, how it is used, and the party responsible for each model element. Because of the unique nature of each project, Document E202 cannot give a blanket declaration of each; rather it lays out a legally binding frame work of rules and then allows for adaption to each unique project (AIA, 2008, p. 1).

AIA Document E202 has been a huge boon to BIM-based contracts. People all across the building industries recognize AIA and have embraced their efforts in simplifying the complex legal environment around BIM. Because BIM is in many respects still new, many of those dealing in construction law simply do not know how to work with BIM. Document E202 created a standard BIM-based contract that addresses many of the legal issues and challenges faced when using BIM.



5.6 THE FUTURE OF BIM AND ITS USE WORLDWIDE

BIM is now used widely all over the world such as the United States, United Kingdom, France, Germany, Finland, Denmark, Australia, Malaysia, and Singapore. Moreover, internationally it is increasingly gaining the attention of the building industry and organizations involved in AEC in addition to the owners and operators of building projects and other structures. BIM Standard efforts in the United States, Europe, and elsewhere in the global arena assume that this digital information is shareable, interoperable among different stakeholders' information systems, based on accepted open standards, and definable in contract language.

Discussing the future of integrated BIM, Dennis Neeley, AIA, Product Director, Reed Construction Data, believes that "Owners need to start immediately setting standards for their BIM projects. They need to provide the objects that their designers will use, or they need to get the manufacturers that they work with to provide the objects. They need to be consistent across all projects. Standardization on space designs, assemblies and objects and the data attached and associated is critical. The Reed SmartBIM site (www.SmartBIM.com) shows the concept, the Spaces section shows how an owner could create complete models of each of their spaces populated with the equipment and furnishing needed, including services like power, communications, etc. During construction, the BIM project must be updated with changes and substitutions. These steps will insure the downstream value and use of the BIM projects. These BIM projects can be integrated into companies GIS systems. The sooner owners get integrated BIM projects (BIM, IPD, and FM) the sooner they will see unbelievable savings."

It should be noted that the application of the global BIM standards will necessitate the reflection of "business views" of information exchanged between AEC and owner/operator interests. The set standards will build upon standards already in use.

Worldwide use of BIM outside the United States

BIM is now widely used in countries around the world such as the United States, United Kingdom, France, Germany, Denmark, Finland, Norway, Iceland, Australia, Malaysia, and Singapore.

5.6.1 United Kingdom

Many firms in the United Kingdom continue to resist using BIM, partly because of the seismic change in culture that it would necessitate. However, this has started to change now that the British government plans to make it compulsory on all public projects, in the belief that this new technology would facilitate improved ways of working that will reduce cost and add long-term value to the development and management of public sector buildings. To help establish BIM on public projects, a task group has been formed headed by Mark Bew to draw a road map and to phase in uptake over a period of 5 years. Recognizing that BIM is not a mature technology yet in the United Kingdom, the level to which it will be mandated on projects will reflect the ability of the industry. However, if this plan is to succeed, the UK construction industry will need to go through a steep learning curve. Still, one example of the successful employment of BIM is at Heathrow Terminal 5 where its use reduced project costs by £210m.

We are now witnessing a surprising upsurge in support for new working methods in the United Kingdom as industry challenges intensify, thereby spurring the UK AEC Industry to make a significant move toward incorporating BIM in its projects. One of the main drivers for the AEC industry to move toward using BIM has been the need to accelerate productivity. Pete Baxter Autodesk senior director Northern Europe, says, “BIM methods of working have been shown to create major efficiencies by eliminating inaccuracies, waste and clashes – and at the same time maintaining transparency and accountability. It’s no surprise that new working challenges have tipped the balance in BIM’s favor.”

In the United Kingdom, the Construction Project Information Committee (CPIC), has the responsibility for providing best practice guidance on the content, form, and preparation of construction production information and making sure this best practice is disseminated throughout the UK construction industry. CPIC, which is formed by representatives of many of the major UK industry institutions, has proposed a definition of BIM for adoption throughout the UK construction industry and has moreover invited all UK industry parties to debate the subject to facilitate reaching an agreed starting point. One of the main stumbling blocks to

adopting a good working method that can significantly improve the quality and sustainability of the deliveries from the design and construction team to the owners is the lack of a clear definition of the term added to the proliferation of interpretations that currently exist.

5.6.2 France

In France, there are a number of organizations that are pushing for a more integrated adoption of BIM standards, to improve software interoperability and cooperation among players of the building industry. Such organizations include the FFB (Fédération française du bâtiment), or the French arm of buildingSMART International who are supporting IFCs. Software editing companies on the other hand such as Vizelia were early adopters of IFCs and are now reaping the benefits from the full potential of BIM in the Green Building newly emerging business.

According to the McGraw-Hill Construction SmartMarket Report (2010), "France has the highest adoption rate of BIM among construction professionals surveyed at 38%, although it is only slightly higher than rates in the UK and Germany." The report goes on to say that "A very high percentage of French adopters (72%) use BIM on 30% or more projects." The report concludes that French users see the most value from BIM through: reduced conflicts during construction (76%) and improved collective understanding of design intent (71%).

5.6.3 Germany

The SmartMarket Report (2010), says that "German adopters as a group use BIM 47% of the time on 30% or more of their projects." In Germany, architects have the highest adoption rate among industry professionals with (77%), followed by engineers (53%) and finally contractors (10%).

The US Army Corps of Engineers' implementation of BIM systems has also now arrived in Europe. The Corps now requires BIM to be used for many projects in its various mission areas and across its divisions, and that number continues to steadily increase. Jim Noble, Engineering Branch chief for the District, says that "Many German firms in private industry are on board with BIM. The challenge for us is that many architects the bauämter uses do not have much experience with BIM." It is expected to take some time to fully incorporate BIM into the Europe District construction process due largely to the legal process as outlined in signed agreements between the United States and German governments that stipulate how BIM projects are to be accomplished in Germany. "Our job now is to get together

with our partners, agree on some parameters, starting points and interpretations and move forward. We're doing just that," according to Noble.

5.6.4 Finland

A higher implementation of BIM in Finland has been achieved than in neighboring Scandinavian countries. Moreover, Finland now requires BIM to be used on all public sector projects. In recent surveys, it was shown that architects were the main users of BIM in their projects (approximately 93%) and engineer's usage was roughly 60%. It should also be noted that there is a great commitment of the Finland's public sector toward wider BIM implementation. Further evidence of this is the BIM guidelines which have been drafted as a result of the R&D ProIt project conducted with industry-wide support. These guidelines are in the Finnish language and cover general fundamentals of product modeling in construction projects, architectural design projects, and structural design projects as well as product modeling in building services design projects. And although these guidelines describe product modeling in detail, they do not provide adequate data exchange specifications, thus providing potential for further development in the guidelines.

BIM advocates in Finland's private sector are also quite active and a number of corporations such as Skanska Oy and "Tekes", are earnestly conducting R&D in BIM. Likewise, research organizations and universities as well as the Association of Finnish Contractors and the state client (Senate Properties) are also active in promoting implementation of BIM in the industry.

5.6.5 Norway

Graphisoft Norway and Solibri, Inc. have partnered in response to an increasing need for BIM quality assurance and Model Checking in Norway. For this reason, BIM is being promoted and used in Norway by various public organizations and contractors including the civil state client Statsbygg and the Norwegian Homebuilders Association. Norway has also recently produced a BIM guidelines based on the experiences from the Statsbygg's HIBO project (prepared in coordination with the NBIMS standard in the United States).

The private sector has also been active in promoting BIM. For example, Selvaag-Bluethink is developing BIM and ICT solutions based on BIM. Norway's SINTEF is the leading organization conducting research in BIM and is a part of Erabuild which is a network of national R&D programs,

focusing on sustainable tools to improve construction and operation of buildings. Moreover, Norway is recognized as being among the first few countries to develop International Framework for Dictionaries (IFD) standard for the construction industry.

5.6.6 Denmark

In 2007, Denmark (like Finland) required BIM to be used on all public sector projects. The overall usage of BIM continues to increase in Denmark. According to a survey conducted in 2006 (cited in Kiviniemi et al., 2008), roughly 50% of architects, and 40% of engineers in Denmark were using BIM for some parts of their projects in 2006. One of the leading Danish user driven organizations is “bips” which has a strong influence in the implementation of IT in the Danish construction industry. Moreover, the mandatory demands on BIM from Danish state clients have moved the use of BIM to a higher level in Denmark.

In the Public Sector, Denmark boasts at least three public agencies that have initiated the implementation of BIM. These are: The Palaces and Properties Agency, The Danish University and Property Agency, and Defense Construction Service. Although government projects in Denmark do not represent a large portion of the total property area, their impact on the market created by the IFC requirements is significant. There are other government agencies like Gentofte Municipality and KLP Ejendommehave which have also adopted the requirements from the Digital Construction project in Denmark.

The Danish government has aggressively outlined its requirements for using BIM in the governmental projects. These governmental requirements are called “Byggherkravene” (Wong et al., 2009). Starting January 2007, all architects, designers, and contractors participating in governmental construction projects are required to adopt a number of new digital routines, approaches, and tools. Under the Digital Construction program initiated by the Danish Enterprise and Construction Authority, a package of guidelines relating to 3D was developed. These guidelines are concerned with both the setting up and fulfilling requirements in file and database-based CAD/BIM applications.

“Bips” is also developing BIM guidelines for the private sector and has adopted the results from the Digital Construction project. It is also promoting new working methods to the Danish Construction Industry. The Danish Enterprise and Construction Authority is an organization supporting BIM R&D in Denmark as well as other Danish organizations and universities

such as Aalborg University which is focused on IFC model servers and 3D Models, and Aarhus School of Architecture which is focusing on product configuration, design intent and IFC model server, and the Technical University of Denmark which is focused on interoperability.

5.6.7 Hong Kong

The construction industry in Asia Pacific is undergoing fundamental changes and is rapidly automating and streamlining its processes to stay abreast with the international business ecosystem. In this respect, Hong Kong is considered to be one of the most advanced countries in the region to adopt building technologies, and Hong Kong has played an important role in setting up standards in the industry. By deploying cutting-edge technologies in its projects, Hong Kong has demonstrated its effectiveness and efficiency in completing world-class building projects.

5.6.8 China

The country is currently experiencing the world's largest construction boom, and BIM is providing a competitive advantage to Chinese architects and engineers. Moreover, the 2008 Beijing Olympics and the 2010 World Expo in Shanghai have prompted the investment of billions of dollars in new construction in those cities and which already have some of the highest commercial and industrial rents in Asia.

The recent building frenzy taking place in China along with its burgeoning pollution problems has induced many Chinese architects to take a keen interest in sustainable design. It goes without saying that using a building information model facilitates the complex design evaluations and analyses that support key aspects of sustainable design and enables the project team to balance China's construction growth with environmental concerns. Moreover, China's rapid building growth presents enormous challenges as well as enormous opportunities. By embracing BIM, China's building industry is able to take advantage of the productivity benefits that surround a digital building methodology, thus giving designers a distinctive competitive edge in the midst of the country's whopping construction boom.

Wuhan Architectural Design Institute (WADI) is one of China's main multidiscipline architectural design firms, with 625 employees, including 242 architects. In 2004, WADI selected Autodesk Revit to help it transition directly from its existing 2D-drafting solution (AutoCAD) to BIM. In preparation for bidding and using the Revit architecture, one WADI



Figure 5.7 The auditorium complex in central China is 15,000 square meters (161,460 sq. ft.).

architect was reportedly able in just 4 days to produce all of the schematic design and presentation documentation for the building shown in [Fig. 5.7](#).

5.6.9 Singapore

Construction and Real Estate Network (CORENET) is Singapore's principal organization for the development and implementation of BIM for government projects. CORENET, a major IT initiative, was launched in 1995 by Singapore's Ministry of National Development. It provides various information services including e-Information Systems such as eNPQS and e-Catalog to its clients, as well as e-Submission and Integrated Plan Checking Systems. IT Standards are being adopted in Singapore's Construction Industry based on the guidelines of International Alliance for Interoperability (buildingSMART).

Singapore also now requires the adoption of BIM for various kinds of approvals such as building plan approvals and fire safety certifications, and the BIM "Integrated plan checking" guidelines are now operational.

Finally, although BIM is a relatively recently discovered technology in an industry that is often slow to adopt change, most early adopters feel confident that it will quickly grow to play an ever more crucial role in building design and construction. BIM has been defined as an integrated process that allows architects, engineers, builders, owners, and other stakeholders to explore a project's key physical and functional characteristics digitally—prior to being built, and although BIM is the future, it is certainly already here now.



Green Building Materials and Products



6.1 OVERVIEW

In construction terms, any material that is used for building purposes can be considered to be building material. And when designing a green building, it is vitally important to carefully consider the choice of materials to be used to achieve the desired sustainability goals. The U.S. Green Building Council (USGBC) believes that building materials choices are fundamental to achieving success in sustainable design. This is due to many factors including the extensive network of extraction, processing, and transportation steps required to process them. Additionally, the numerous activities normally required to create building materials may have a negative impact on the environment by polluting the air, water, destroying natural habitats, and depleting natural resources. Also, incorporating green products into a project should not imply sacrifice in performance or aesthetics nor does it necessarily entail higher project cost.

History shows us that for thousands of years, man has used naturally occurring materials, such as clay, sand, reed, wood, and stone, to construct his habitat. But in addition to naturally occurring materials, man has, with the passing of time, developed and supplemented these with a variety of man-made products—some more and some less synthetic. Moreover, building materials manufacture has long been an established industry in many countries around the world, from the United States to China and Iraq, and their use is typically compartmented into specific specialty trades, such as carpentry, roofing, flooring, and plumbing.

The concept of repair and reuse of a building instead of tearing it down and building new structure is a highly effective strategy for minimizing environmental impact. And refurbishment and rehabilitation of existing building components helps minimize any potential negative impact on the environment and saves natural resources, including the raw materials, energy, and water resources required for new construction. It also helps reduce pollution that might take place as a by-product of manufacturing,

extraction, and transportation of raw materials, in addition to minimizing the creation of solid waste that often ends up in landfills.

Some states, such as North Carolina, have a Building Reuse and Restoration Grants Program that provides grants for the restoration and upfitting of vacant buildings in rural communities or in economically distressed urban areas, as well as for the expansion and renovation of buildings currently occupied by certain types of businesses. Many rating systems including the USGBC's LEED Rating System also recognize the importance of building reuse. Reusing a building can contribute to earning points under LEED "Materials Resource Credits on Building Reuse". Of note, according to the USGBC, project teams may pursue the entire LEED v4 Materials and Resources (MR) category in place of the MR credits from LEED v2009 but all prerequisites must be met including:

- Storage and collection of recyclables (Required)
- Construction and demolition (C & D) waste management planning (Required)
- Building life-cycle impact reduction Up to 5 points
- Building product disclosure and optimization—environmental product declarations Up to 2 points
- Building product disclosure and optimization—sourcing of raw materials Up to 2 points
- Building product disclosure and optimization—material ingredients Up to 2 points
- C & D waste management Up to 2 points

6.1.1 Definition of Green Building Material and Products

Green building materials cover a vast area of themes and materials. The application and use of these materials further complicates the subject. Moreover, green building means different things to different people—it is a multifaceted concept that lends itself to numerous interpretations. Likewise, Green building materials defy easy definition; one characteristic is that they are ecofriendly and are composed of renewable, rather than nonrenewable resources. In general, building materials are called "green" because they have minimal or no negative impact on the environment (and in some cases may even have a positive impact). It should be noted that there is no perfect green material, but in practice, there is an upsurge in number of materials on the market that reduce or eliminate negative impacts on people and the environment. And especially today, with building and construction activities worldwide consuming billions of tons of raw materials each year, it has become increasingly imperative to employ green

building materials and products and so help in the conservation of dwindling nonrenewable resources internationally.

Many green materials are made from recycled materials, which help the environment and puts waste to good use in addition to reducing the energy required to make them. Building materials are also considered green when they are made from renewable resources that are sustainably harvested. An example of this is flooring that is made from sustainably grown and harvested lumber or bamboo. Durability is another characteristic of a sustainable product, and some building materials are considered to be green mostly because they are very durable. A typical example of this is a durable form of siding that outlasts less durable products, resulting in substantial savings in energy and materials over the lifetime of a property. Additional benefits can be achieved when a durable product is made from environmentally friendly materials, such as recycled waste.

6.1.2 Natural Versus Synthetic Materials

Building materials generally fall into one of two classifications, natural and synthetic. Natural building materials are those materials that have not gone through any process or minimally processed by industry, such as timber or glass. Synthetic materials, on the other hand, are made in industrial settings and gone through processing after considerable human manipulations; they include plastics and petroleum-based paints. Both have their advantages and disadvantages.

Clay, mud, stone, and fibrous plants (e.g., bamboo and reeds) are among the most basic natural building materials. These materials are being used together by people all over the world to create shelters and other structures to suit their local habitat. In general, stone and/or brush are used as basic structural components in these buildings, while mud is generally used to fill in the space between, acting as a form of mortar and insulation.

In many cases, it has been clearly demonstrated that natural materials cannot cope with nor meet the required specifications of today's industrial challenges of the construction industry. Plastic is a case in point and a good example of a typical synthetic material. The term "plastic" covers a range of synthetic or semisynthetic organic condensation or polymerization products that can be molded or extruded into objects, films, or fibers. The term is derived from the material's malleable nature when in a semiliquid state. Plastics vary immensely in heat tolerance and are hard-wearing, highly adaptable, can be molded and cast in a variety of forms, and can mimic, and perform the task of, most other building materials. Plastics continue to be viewed as a potential replacement for other natural building materials.

Combined with this adaptability, its general uniformity of composition and lightness facilitate its use in almost all industrial applications.

A material's "greenness" is generally based on certain criteria; we mentioned its durability and also whether the material is renewable and resource efficient in its manufacture, installation, use, and disposal. Other considerations are whether the material is ecofriendly and supports the health and well-being of occupants, construction personnel, and the public; whether the material is appropriate for the application, and what the environmental and economic tradeoffs among alternatives are.

Considerable research remains to be conducted to enable persons to satisfactorily evaluate alternatives and select the best material for a project. Appropriate material selection should consider a number of factors including its impact throughout its life cycle (from raw-material extraction to use and then to reuse, recycling, or disposal). A life-cycle assessment (LCA) is a systematic set of procedures for compiling and examining the inputs and outputs of materials and energy and the associated environmental impacts directly attributable to the functioning of a product or service system throughout its life cycle. The areas of impact to consider at each stage in the life cycle of a material include:

- Energy required for extraction, manufacturing, and transport
- Natural-resource depletion; air and water pollution; hazardous- and solid-waste disposal
- Energy performance in useful life of material and its durability
- Impact of material or product on indoor air quality (IAQ); exposure of occupant, manufacturer, or installer to harmful/toxic substances; moisture and mold resistance; cleaning and maintenance methods

Properties that typical green building materials and products may share include:

- Recyclability of building material or reusable when no longer required
- Sustainably harvested from rapidly renewable resources such as genuine linoleum flooring, bamboo flooring, wool carpets, strawboard, cotton ball insulation (made from denim scrap). Using rapid renewables helps reduce the use and depletion of finite raw materials
- Durability
- Minimal toxic emissions generated by the product
- Wood or wood-based materials meet Forest Stewardship Council's (FSC) Principles and Criteria for wood building components
- May contain postconsumer recycled content
- Can be salvaged for reuse, refurbished, remanufactured, or recycled

- Manufactured from a waste material such as straw or fly ash or a waste-reducing process
- Minimally packaged and/or wrapped with recyclable packaging
- Locally extracted and processed, which means less energy used in extraction, processing, and transport to the job site. Regional economies are helped by using materials and products manufactured regionally
- Water-efficient
- Manufactured with a water-efficient process
- Energy-efficient in use
- Minimal waste and pollution generated in the manufacturing process
- Generates renewable energy
- Financial viability

6.1.3 Storage and Collection of Recyclables

According to LEED the intent of this prerequisite is essentially to reduce the waste that is generated by building occupants and hauled to and disposed of in landfills by encouraging the storage and collection of recyclables. Thus, “Storage and Collection of Recyclables” is a MR prerequisite in most of the LEED Rating System categories. This is also why LEED stipulates that an area needs to be provided that is dedicated to recycling inside the building, so that occupants can have the option to recycle their paper, cardboard, glass, plastic, and metals. This recycling means that there is a reduction in the need for virgin materials as well as a significant reduction in the amount of waste otherwise going to landfills.

It should be noted that LEED has not set any specific standards or requirements for this area, but the USGBC guidelines ([Table 6.1](#)) state that the area should be easily accessible, serve the entire building(s), and be dedicated to the storage and collection of nonhazardous materials for recycling. The average waste per employee is estimated to be about 3 pounds per day! It is therefore important that the building occupants have the option to maintain good recycling programs throughout the lifespan of the building.



6.2 LOW-EMITTING MATERIALS

The intent of low-emitting materials is to reduce concentrations of chemical contaminants that can damage air quality, human health, productivity, and the environment. This is partly why most major manufacturers and suppliers today offer a low-emitting option for any of the materials recommended for credits in the Indoor Environmental Quality section of the

Table 6.1 Recycling storage-area guidelines based on overall building square footage

Commercial building (square footage)	Minimum area (square footage)
0 to 5,000	82
5,001 to 15,000	125
15,001 to 50,000	175
50,001 to 100,000	225
100,001 to 200,000	275
200,001 or greater	500

Source: USGBC.

LEED Building Design & Construction reference guides. “Green” appears to be the latest trend, and everyone’s trying to get in and hop on the bandwagon. People are increasingly seeking out “healthy” buildings to live and work in. LEED addresses low-emitting materials within the Indoor Environmental Quality section of this book. Among the most straightforward credit to earn, of the IEQc4 credits, is IEQc4.5, particularly if you choose to meet the credit by using Greenguard Indoor Air Quality certified furniture. For the latest LEED updates, visit www.usgbc.org. Low emitting materials.

With respect to the New Construction rating system, credits MR4.1–4 relate to low-emitting materials such as adhesives and sealants, paints and coatings, flooring systems, and composite wood and agrifiber products.

Many of the environmental impacts associated with building materials have already taken place by the time the materials are installed. Pollutants are emitted during the extraction from the ground, or harvesting from forests, and during manufacture. Energy has therefore been invested throughout production. Certain materials, such as those containing ozone-depleting HCFCs and volatile organic compound (VOCs), may continue emitting pollutants during their life cycle. Some materials will also have negative environmental impacts associated with their disposal. Important considerations to bear in mind when selecting building materials and products include the following:

- Avoid materials and products that generate substantial amounts of pollution (VOCs, HCFCs, etc.) during manufacture or use.
- Specify salvaged building materials or that is produced from waste or contain postconsumer recycled content.
- Avoid materials made from toxic or hazardous constituents (benzene, arsenic, etc.).
- Specify materials with low embodied energy (the energy used in resource extraction, manufacturing, and shipping).

- The regional economy and the environment are helped by using materials and products manufactured regionally.
- Encourage environmentally responsible forestry by using wood or wood-based material that meets FSC's Principles and Criteria for wood building components and avoid materials that unduly deplete limited natural resources, such as old-growth timber.

This credit adds new international compliance options for projects outside of North America. Moreover, project teams will now have to identify the total surface area for flooring/ceilings, walls, and insulation, and the surface area with compliant materials for each category. Of note, there are various resource-efficient products that are available at no extra charge, while others may cost more. Also, if the installation differs from standard practice, it may raise labor cost if an installer is unfamiliar with a product.

6.2.1 Adhesives, Finishes, and Sealants

The New Construction credit template for IEQc4.1, low-emitting adhesives and sealants, for example, requires the project manager or specifier to list all indoor adhesives, sealants, and sealant primer products to be used on the project and input the following information:

- Name of Product Manufacturer
- Product Name and Model
- Product VOC Content (g/L)
- Source of VOC Data
- South Coast Air Quality Management District (SCAQMD) Rule #1168 as of 2007) Allowable VOC Content (g/L), as indicated in [Fig. 6.1](#). Aerosol adhesives not covered by Rule 1168 must meet Green Seal Standard GS-36 requirements in effect on October 19, 2000. All indoor-air contaminants that are odorous, potentially irritating, and/or harmful to the comfort and well-being of installers and occupants should be avoided or minimized.

An important characteristic of Sealants is that they can increase the resistance of materials to water or other chemical exposure, while caulks and other adhesives can assist in controlling vibration and strengthen assemblies by spreading loads beyond the immediate vicinity of fasteners. These properties enhance durability of surfaces and structures, but they do so at a cost, because very often they are shown to be hazardous in manufacture and application. Moreover, construction-adhesive formulas often contain in excess of 30% volatile petroleum-derived solvents, such as hexane, to maintain liquidity until application. This has caused workers to become exposed to toxic solvents; and, as the materials continue to outgas during curing, the occupants may be potentially exposed to emissions for extended periods.

Architectural Applications (SCAQMD 1168)	VOC Limit (g/L less water)	Specialty Applications (SCAQMD 1168)	VOC Limit (g/L less water)
Ceramic tile	65	Welding: ABS (avoid)	325
Contact	80	Welding: CPVC (avoid)	490
Drywall and panel	50	Welding: plastic cement	250
Metal to metal	30	Welding: PVC (avoid)	510
Multipurpose construction	70	Plastic primer (avoid)	650
Rubber floor	60	Special-purpose contact	250
Wood: structural member	140		
Wood: flooring	100	Sealants and Primers (SCAQMD 1168)	
Wood: all other	30	Architectural porous primers (avoid)	775
All other adhesives	50	Sealants and nonporous primers	250
Carpet pad	50	Other primers (avoid)	750
Structural glazing	100		
		Aerosol Adhesives (GS-36)	VOC Limit
Substrate-Specific Applications		General-purpose mist spray	65%
Fiberglass	80	General-purpose web spray	55%
Metal to metal	30	Special-purpose aerosol adhesives	70%

VOC weight limit is based on grams/liter of VOC minus water. Percentage is by total weight

Figure 6.1 Adhesives, sealants, and sealant primers: South Coast Air Quality Management District (SCAQMD) Rule #1168. VOC limits are listed in the table and correspond to an effective date of July 1, 2005 and rule-amendment date of January 7, 2005. *Source: USGBC.*

Industry tests indicate that water-based adhesives work as well as or better than solvent-based adhesives and can pass all relevant ASTM and APA performance tests. Also, water-based adhesives can be purchased at comparable costs from numerous manufacturers, and when adhesives are purchased in bulk, larger containers can often be returned to vendors for refill.

Most stains and sealants also emit potentially toxic VOCs into indoor air. One way of managing this problem is by employing materials that do not require additional sealing, such as stone, ceramic and glass tile, and clay plasters. The toxicity and the air and water pollution generated by the manufacture of chlorinated hydrocarbons such as methylene chloride strongly reinforces the need for responsible, effective alternatives, such as plant-based, nontoxic, or low-toxicity sealant formulations.

LEED requires that all adhesives and sealants used on building interiors (defined as inside the weatherproofing system and applied on-site) need to comply with the reference standards shown in Fig. 6.1. Environmentally preferable cleaning methods and products can lessen indoor-air pollution and solid/liquid waste generation. Safe cleansers are readily available and are competitively priced and ecofriendly. The improper use and disposal of some common cleaning and maintenance products can contribute to indoor-air contamination, toxic waste, and water pollution.

The active ingredients in cleaners are surfactants, of which biodegradability is a key factor. Even low surfactant concentrations in runoff have shown to pose risks to the environment. Petroleum-derived surfactants generally break down more slowly than vegetable oil-derived fatty acids; some materials are even resistant to municipal sewage treatment. The harmful effects of toxins can be minimized by implementing the following:

- Storing hazardous materials outside the building envelope.
- Select materials with a durable finish and that do not require frequent stripping, waxing, or oiling (such as linoleum, cork, or colored concrete).
- Select products that have approved third-party or government-agency certification:

Green Seal, Scientific Certification Systems (SCS), Environmental Protection Agency (EPA) Environmentally Preferable Purchasing Program, General Services Agency, California Integrated Waste Management Board (CIWMB) Recycled Content Product Directory

- Whenever possible, select biodegradable, nontoxic cleansers.
- Avoid selecting cleansers, waxes, and oils that are labeled as toxic, poisonous, harmful, or fatal if swallowed, corrosive, flammable, explosive, volatile, requiring “adequate ventilation” or safety equipment, or causing cancer or reproductive harm.
- Place mats at all building entrances to minimize stripper use; refinish only areas where the finish surface is wearing; clean regularly, and dust-mop and/or vacuum frequently and wet mop with a liquid cleaner.

6.2.2 Paints and Coatings

Paints generally consist of a mixture of solid pigment suspended in a liquid medium and applied as a thin, (often opaque) coating to a surface for protection and/or decoration. Primers are the first coat in a paint system (i.e., basecoats), whose main function is to increase the adhesion between substrate and the total paint system (i.e., of subsequent coats of paint or varnish). Sealers are also basecoats and are applied to a surface with the

main function of helping reduce the absorption of subsequent coats of paint or varnish and to prevent bleeding through the finish coat by sealing in aggressive chemicals (e.g., alkalinity). Paint was first used on a large scale thousands of years ago by the Egyptians and Babylonians in their buildings and temples.

It should be noted that the LEED Guidelines for Paints, Coatings, and Primers may vary from one LEED Program to another, although USGBC has made a determined effort to make this credit more consistent through the introduction of LEED 09. Also, LEED considers Paints and Coatings as referring only to paints and coatings used on the interior of the building, since exterior paints will not affect a building's "indoor air quality." Generally speaking, the USGBC requires that paints and coatings applied on-site and used on the interior of the building (defined as inside the weatherproofing system) must comply with the following referenced standards:

- Architectural paints, coatings, and primers applied to interior walls and ceilings: Do not exceed the VOC content limits established in Green Seal Standard GS-11. Of note, Green Seal redesigned GS-11 to promote the creation of safer coatings by restricting a comprehensive list of harmful chemicals, including heavy metals, certain phthalates, formaldehyde donors, carcinogens, mutagens, reproductive toxins, hazardous air pollutants, and ozone-depleting compounds.
- Anticorrosive and antirust paints applied to interior ferrous metal substrates: Do not exceed the VOC content limit of 250 g/L established in Green Seal Standard GC-03, *Anti-Corrosive Paints*, Second Edition, January 7, 1997.
- Clear wood finishes, floor coatings, stains, and shellacs applied to interior elements: Do not exceed the VOC content limits established in SCAQMD Rule 1113, *Architectural Coatings*, for January 1, 2004. [Table 6.2](#) shows the allowable VOC levels stipulated by SCAQMD.

Santa Cruz County officials often point out that paint can have significant environmental and health implications in its manufacture, application, and disposal. Most paint, even water-based "latex," is derived from petroleum. Its manufacture requires substantial energy and water and creates air pollution and solid/liquid waste. VOCs are typically the pollutants of greatest concern in paints. VOCs from the solvents found in most paints (including latex paints) are released into the atmosphere during manufacture and application and for weeks or months after application. VOCs emitted from paint and other building materials are associated with eye, lung, and skin irritation, headaches, nausea, respiratory problems, and liver and kidney damage. Manufacturers

Table 6.2 Allowable volatile organic compound levels in paints and finishes

Type	Limit (g/L)
Paints	
Flat	50
Nonflat	50
Primers, sealers, and undercoats	100
Quick-dry enamels	50
Finishes	
Clear wood	Varnish, 350
	Lacquer, 550
Floor coatings	100
Sealers	Waterproofing, 250
	Sanding, 275
	All others, 200
Shellacs	Clear, 730
	Pigmented, 550
Stains	250

Note: Grams/liter less water and exempt compounds, according to SCAQMD.

continue to employ the latest technology to reduce the VOCs found in these paints while maintaining costs at a reasonable level.

Although exposure to solvents emitted by finish products can be significant, renewable alternatives, such as milk paint, addresses many of these concerns. In this case, there may be a premium price to pay, and some products may not be suitable for exterior applications. Paint manufacturers have started to produce reformulated low- and zero-VOC latex paints with excellent performance in both indoor and outdoor applications and which can be purchased for the same or lower price than older high-VOC products. Paints that meet GS-11 standard meet stringent performance criteria and are low in VOCs and aromatic solvents, do not contain heavy metals, formaldehyde, or chlorinated solvents.

There are other alternative paints on the market such as silicate paints which are solvent free and may be used on concrete, stone, and stucco. Silicate paints have many advantages; they are odorless, nontoxic, vapor permeable, naturally resistant to fungi and algae, noncombustible, colorfast, light reflective, and even resist acid rain. Though silicate paints are more expensive, their extraordinary durability provides some compensation, plus the fact that these paints cannot spall or flake off and will only crack if the substrate cracks.

6.2.3 Flooring Systems

There are many kinds of flooring systems available in today's marketplace, from nonmagnetic access flooring systems to carpet, wood block, and resinous flooring. Each system is designed to meet different requirements and to satisfy the rigorous demands of high-traffic commercial, residential, and institutional applications as well as the aesthetic requirements for high-visibility public and private facilities. "Green" flooring is nontoxic, environmentally friendly and made from sustainably harvested, recycled, or reclaimed sources.

Carpet

Carpet is a very controversial material and in most cases, it is not considered to be green. And as with any product, significant environmental impacts can occur throughout a carpet's life cycle—i.e., its manufacture, use, and disposal. By considering a variety of life cycle attributes, from the materials used to manufacture and install carpet to recycling and disposal issues, purchasers can make informed decisions about carpet, including the potential health concerns it presents.

Various VOCs can be emitted from carpet materials, although VOC emissions from new carpet usually fall to very low levels within 48–72 h after installation if good ventilation is provided.

Most carpet products are synthetic, usually derivatives of nonrenewable petroleum products; their manufacture requires substantial energy and water and creates harmful air and solid/liquid waste. Today, however, many carpets are being manufactured with recycled content (e.g., plastic bottles), and moreover, a growing number of carpet manufacturers are refurbishing and recycling used carpets into new carpet. At the end of its useful life, most carpet tends to end up in landfills, and the EPA states that "Over four billion pounds of carpet enter the solid waste stream in the U.S. every year, accounting for more than one percent by weight and about two percent by volume of all municipal solid waste (MSW)."

Carpet remains the most popular floor covering in the United States and is installed on nearly 70% of our floors. Synthetic carpeting is the most common line of products, constructed from petroleum-based materials that have been linked to health concerns. Carpets, their backings, and adhesives used with carpets have been shown to off-gas many unhealthy VOCs, all of which pollute indoor and outdoor air. Nylon is the most popular fiber used as the face fiber in commercial carpet. Polypropylene (olefin), PET, and recycled PET are also employed in carpet face fiber. In general, carpet made

from PET and polypropylene face fiber is not as durable as carpet made from nylon face fiber. Redesigned carpets, new adhesives, and natural fibers are now available that emit low or zero amounts of VOCs. For improved air quality, selected carpets and adhesives should meet a third-party standard, such as the Carpet and Rug Institute (CRI) Green Label Plus or the State of California's Indoor Air Emission Standard 1350.

From an environmental standpoint, natural fibers are an ecofriendly and preferable carpeting option because they are renewable and biodegradable. A traditional material is wool, and in many parts of the world, sheep are still raised specifically for carpet fibers. Wool carpets are more durable than synthetics, resist dust mites, moisture, and fire and also can be more comfortable under foot. Wool carpets often use jute backing, upping the sustainable nature of these carpet products. Other natural fiber options include sisal, seagrass, abaca, coir, and wool floor coverings. One of the disadvantages of carpets is that they tend to harbor more dust, allergens, and contaminants than many other materials (Fig. 6.2). Durable flooring, such as a concrete-finish floor, linoleum, cork, or reclaimed hardwoods, is generally preferable in helping to improve IAQ.

The LEED intent of low-Emitting carpet systems is to reduce the quantity of indoor-air contaminants that are odorous and potentially irritating and or harmful to the comfort and well-being of installers and occupants.



Figure 6.2 Photo of FLOR carpet squares laid in a flexible and practical “tile” format. The tiles are made from renewable and recyclable materials and are available in a range of colors, textures, and patterns. More than two million tons of carpets are landfilled in the United States each year. *Courtesy: FLOR, Inc.*

Additionally, for LEED credits, all carpet installed within a building's interior must meet or exceed testing and product requirements of the CRI Green Label Plus program for VOC emission limits. Carpet pads installed within a building's interior must also meet or exceed CRI's Green Label program for VOC emission limits. Adhesives and sealants used in carpet-system installation must comply with SCAQMD Rule #1168.

The EPA has developed five guiding principles to help federal government purchasers incorporate environmental considerations into purchasing decisions and which provide a framework purchasers can use to make environmentally preferable purchases. They are:

1. Include environmental factors as well as traditional considerations of price and performance as part of the normal purchasing process.
2. Emphasize pollution prevention early in the purchasing process.
3. Examine multiple environmental attributes throughout a product's or service's life cycle.
4. Compare relative environmental impacts when selecting products and services.
5. Collect and base purchasing decisions on accurate and meaningful information about environmental performance.

It should be noted that in LEED 2009 NC, C&S, and CI, the title of EQ 4.3 has been changed from Carpet to Flooring Systems, and this credit has been substantially expanded. From 2009 onward, LEED has stipulated that all hard-surface flooring must be certified as compliant with the FloorScore standard by an independent third party (Third-party certification means that an independent organization has reviewed the manufacturing process of a product and has independently determined that the final product complies with specific standards for safety, quality or performance). FloorScore is a program developed by the Resilient Floor Covering Institute (RFCI) together with SCS to test and certify flooring products and flooring adhesive products for compliance with IAQ emissions targets. Flooring products covered by FloorScore include vinyl, linoleum, laminate flooring, wood flooring, ceramic flooring, rubber flooring, wall base, and associated sundries. A FloorScore certification means healthier, cleaner air and therefore healthier living/working conditions.

Polyvinyl Chloride/Vinyl

PVC or Polyvinyl chloride is also referred to as "Vinyl," is one of the most widely used synthetic materials in building and construction due to its durability, versatility, and cost. In addition to flooring, PVC is common in

pipes, vinyl siding, vinyl flooring, wire insulation, conduit, window frames, packaging, wall covering, roofing, and many other products. PVC is generally transparent with a bluish tint. It is attacked by many organic solvents but has a very good resistance to oils, and it has a low permeability to gases. In its rigid form, PVC is available in sheets which can readily be welded to produce tanks, trays, and troughs. It is not recommended for use above 158°F (70°C) although it can be taken to 176°F (80°C) for short periods. PVC is important because it accounts for nearly 50% of total plastic use in construction and because it is increasingly recognized as problematic. Vinyl is common place today with about 14 billion pounds being produced annually in North America. It is inexpensive, and not all of its alternatives have yet worked out all their negative issues. Moreover, as the USGBC suggested in its long-awaited report on PVC, all materials have potential pitfalls, from IAQ to disposal. PVC is difficult to recycle for many reasons including its high chlorine content which makes recycling complicated and expensive because it cannot be mixed with other plastics.

It is said that vinyl composition tile (VCT) accounts for more square footage than any other category of resilient flooring. Today, millions of square feet of VCT have been installed around the world, in commercial buildings, retail stores supermarkets, hospitals, and schools. VCT has been extensively used because of its benefits: good strength relative to its weight, durability, water resistance, and adaptability. Vinyl tends to be inexpensive, in part because production typically requires roughly half the energy required to produce other plastics. Products made from vinyl can be resistant to biodegradation and weather and are effective insulators. The physical properties of vinyl can be tailored for a wide variety of applications. Many firms are increasingly concerned about difficulty in recycling VCT and the negative environmental impacts this creates and are therefore struggling to find appropriate alternatives.

Vinyl/PVC's main problem is its "Toxic Lifecycle"; its life cycle begins and ends with hazards, most stemming from chlorine, its primary component. Chlorine makes PVC more fire resistant than other plastics. The production of PVC requires hazardous chemicals such as vinyl chloride (a simple chemical made of chlorine, carbon, and hydrogen), which causes cancer, and very hazardous chemicals are by-products of that same production, including dioxin and PCBs. Lead, cadmium, and other heavy metals are sometimes added to vinyl as stabilizers; and phthalate plasticizers, which give PVC its flexibility, pose potential reproductive risks. Also, some consumer products such as phthalates can over time leach out or off-gas harmful chemicals, exposing building occupants

to materials linked to reproductive-system damage and cancer in laboratory animals. Manufacturing vinyl or burning it in incinerators produces toxic by-products including dioxins, which are among the most toxic chemicals known to man. Research has shown that the health effects of dioxin, even in minute quantities, include cancer and birth defects.

PVC is one of the most environmentally hazardous consumer materials being produced. It is a strong thermoplastic material that is made from vinyl chloride monomer (VCM) and ethylene dichloride, both of which are carcinogens and acutely toxic. The production of PVC causes the release of these toxic carcinogens into the environment, and there is no way to confidently quantify these hazards and upset condition impacts for an LCA or risk analysis. Clean-air regulation and liability concerns have been effective in reducing total VCM releases since 1980, while PVC use has roughly tripled. Most PVC products are believed to be basically harmless when properly used. However, some of the additives and softeners can leach out of certain vinyl products. And although PVC resin is inert in normal use, older PVC products are frequently contaminated with traces of VCM (many of the older landfills have been releasing toxic fluids for decades), which can leach into the surrounding environment and contaminate drinking water.

There are many possible substitutes on the market which may cost more or require different maintenance, but many of these alternatives can outlast plastics with proper care. Moreover, for many applications, particularly indoors where occupants can be directly exposed to off-gassing plasticizers, substitution of vinyl would clearly be prudent for maintaining health and well-being of occupants. Below are some potential examples of possible material alternatives:

- Flooring made from cork, natural linoleum, tile, finished concrete, or earth
- Stucco, lime plaster, reclaimed wood, fiber-cement, and FSC-certified wood siding
- Natural wall coverings instead of vinyl wallpaper
- Windows framed with fiberglass, FSC-certified wood, or possibly wood-based composites utilizing formaldehyde-free binders
- Substituting glass shower doors instead of vinyl curtains

Tile

Tile production is an ancient process, dating back to ancient Babylonian and Egyptian times. Tiles typically start out in the earth, where the raw materials are quarried and refined. Once the raw materials are quarried, prepared,

and properly mixed, the tiles can be formed. Tiles are primarily made from fired clay (porcelain and other ceramics), glass, stone or cement; it provides a useful option for flooring, countertops, and wall applications whose principal environmental requirement is durability. Tile is very durable, even in high-traffic areas, eliminating the waste and expense of replacements. Tile production, however, is energy intensive, although tile made from recycled glass requires less energy than tile made from virgin materials. Among tiles' positive attributes is that they do not burn, will not retain liquids, and do not absorb fumes, odors, or smoke and, when installed with low- or zero-VOC mortar, can contribute to a building's good IAQ. But such tile performance can only be achieved if it has the appropriate surface hardness for the location. Tile hardness is measured on the Porcelain Enamel Institute (PEI) scale of 0–5, with 0 being the least hard, indicating a tile that should not be used as flooring, and five signifying a surface designed for very heavy foot traffic and abrasion. Floor tiles can easily last as long as the building they are installed in if properly maintained.

The environmental impacts of mining, producing, and delivering a unit of tile requires important considerations, although ceramic tiles production today have a lower environmental impact compared with other materials, thanks to an intense activity of technological, and production innovations conducted by the ceramics industry. Most of the tiles used in the United States today, are imported (roughly 75%). The remaining amount represents about 650 million square feet of ceramic tile produced by U.S. factories each year, together with the billions of square feet manufactured globally. This requires mining millions of tons of clay and other minerals and substantial energy to fire material into hardened tile. Once the raw materials are processed, a number of steps are put into motion to obtain the finished product. These steps include batching, mixing and grinding, spray-drying, forming, drying, glazing, and firing. In modern facilities, many of these steps are now accomplished using automated equipment. Stone, while requiring relatively little energy to process, nevertheless, requires significant energy to quarry and ship. Selecting tile produced regionally may dramatically reduce the energy use and pollution of transport and thus facilitate achieving a LEED credit.

In the United States, more than 95% of the tile industry's product consists of glazed or unglazed floor tile and wall tile, including quarry tile and ceramic mosaic tile (Fig. 6.3). Due to the industry's focus on decorative tiles, it has become completely dependent on the economic health of the construction and refurbishing industries. The only real difference between



Figure 6.3 Interior showing installation of Crystal Micro double-loading polished tile.
Source: Foshan YeShengYuan Ceramics Co. Ltd.

the production process for ceramic glazed tile and ordinary ceramic tile is that the glazed tile includes a step known as glazing. There are many ways to glaze ceramic tile; basically, it requires a liquid made from colored dyes and a glass derivative known as flint that is applied to the tile, either using a high-pressure spray or by direct pouring. This in turn gives a glazed look to the ceramic tile. Tile in low-traffic areas, particularly roofing, may use lower-impact water-based glazes. Glazed tiles have the advantage of being practically stainproof, even though they can be more slippery. Unglazed tiles on the other hand are generally more slip resistant but may require a sealant. Also, the integral color and generally greater thickness of unglazed tiles tend to make them more durable than glazed tiles. Factory-sealed tiles can help minimize or eliminate a source of indoor VOC emissions. Glass floor tile can also offer a nonskid surface appropriate for ADA compliance. When installing stone tile, especially for countertop applications, a nontoxic sealer should be used for the grout and tile surface. Also, it is important that the final product meets certain specifications regarding physical and chemical properties. These properties are determined by standard tests established by the American Society of Testing and Materials (ASTM). The ASTM tests measure properties such as abrasion resistance, chemical resistance, mechanical strength, dimensional stability, water absorption, frost resistance, and linear coefficient of thermal expansion.

6.2.4 Earthen Building Materials

Earthen building materials were used from Neolithic times—even before the invention of writing. But the techniques and methods for earth construction are numerous and vary with culture, climate, and resources. The primary types of earthen building materials include adobe bricks, made from clay, sand, and straw; rammed earth, compressed with fibers for stabilization; and cob, made of clay, sand; and straw that are stacked and shaped while wet, as well as wattle and daub and earth plasters and finishes. Provided they are obtained locally, earthen building materials can reduce or eliminate many of the environmental problems posed by conventional building materials since they are plentiful, nontoxic, biodegradable, and reusable. Well-built earthen buildings are known to be durable and long lasting and require little maintenance.

For thousands of years, people throughout the world have built comfortable homes and communities with earthen materials that provide excellent shelter. Though the domestic popularity of earthen materials waned during the 20th century, a revival has emerged since the 1970s. By contrast, modern “stick-frame” construction, which requires specialized skills and tools, has been a standard practice in the United States only since the end of World War II and remains today uncommon in many parts of the world. Main considerations in regard to earthen construction include:

- Earthen construction is generally labor intensive, although minimal skill is required.
- Earthen walls are thick and may comprise a high percentage of floor area on a small site, making its use inappropriate.
- Multistory and cob structures require post-and-beam designs.

It may be more difficult to obtain necessary permits in certain jurisdictions, although code recognition and structural testing are available in most states. Also, unit production costs will differ in relation to local conditions including availability of soil and its suitability for stabilization, etc. If labor is done primarily by building professionals, the square-foot cost of earthen construction is comparable to conventional building methods. Advantages and benefits of earthen materials include:

- Abundance of the raw material—earth.
- They are durable and require low maintenance.
- They are ecofriendly with minimal environmental impact, provided materials come from local sources.
- High thermal insulating properties. Thermal mass helps keep indoor temperatures stable, particularly in mild to warm climates.

- High sound insulation.
- No waste generated during construction.
- They are biodegradable or reusable.
- Construction is inexpensive and simple, with high workability and flexibility. Structures are therefore easy to build, requiring few special skills or tools.
- When well designed, they provide pleasing aesthetics.
- They are highly resistant to fire.
- Not susceptible to insects or rodents.
- Inert—contains no toxic substances—therefore require no toxic treatments and do not off-gas hazardous fumes, thus are good for chemically sensitive individuals.

Earthen flooring, also called adobe floor, varies in its construction but is generally durable, inexpensive, an ecologically sustainable solution, and uniquely aesthetic complement to a home or office. Since “dirt” is abundantly plentiful and indigenous, earthen flooring can save money and virtually eliminates the waste, pollution, and energy necessary to manufacture a floor. The use of earth floors in the United States are still most often confined to outbuildings and sheds, but, if properly installed, can also be used in interior spaces (Fig. 6.4). For interior use, earth floors must be properly insulated, moisture sealed, and protected from capillary action of water by sealing with a watertight membrane underlayment. Oftentimes, an earthen floor may be constructed of two or three layers. A typical earthen floor might include 70% sand and 30% clay, with lots of chopped straw for much needed tensile strength.

Prior to proceeding with construction, the removal of any vegetation under the floor area is needed, followed by ramming of the area. The ground must be dry before installation of the floor. After the surface is moisture



Figure 6.4 Illustration showing the method for installing an earth floor. Source: Brian “Ziggy” Liloia, “Building My Cob House” blog.

proofed, a foundation of stone, gravel, or sand is installed, 8–10 inches (20–25 cm) deep. An insulating layer such as a straw-clay mixture is then installed. The key to a good earthen floor is the proper mixture of dirt, clay, and straw. Stabilizers such as starch paste, casein, glues, or Portland cement are sometimes added to obtain a harder floor. Earthen floors are first troweled to a smooth finish and then usually sealed with an oxidizing oil such as linseed or hemp oil, which hardens it. Sweep or vacuum any loose debris and dust, as well as possible light mopping or sponging. Time should be given for the moisture to dry before applying the oil.

Considerations and attributes of earthen-floor installation include:

- Earthen material is generally inexpensive when found locally.
- Construction waste elimination; any excess earth can be reincorporated into the landscape.
- Earthen materials are easy to process and require little or no transport and therefore produce minimal to zero pollution. Even when produced by a machine, a finished earthen slab is estimated to have 90% lower embodied energy than finished concrete.
- Earthen floors are durable with proper maintenance and repairable and when properly sealed can be swept or moist mopped; stabilized earthen flooring is not dusty.
- It is labor intensive to install. Not a problem in developing countries where labor is very cheap.
- In high-traffic areas such as entries or workspaces, flagstones or other protective materials may be required.
- More durable than vinyl because it is repairable but more vulnerable to scratching and gouging than hard tile or cement.
- Few contractors in the United States are experienced in the installation of earthen flooring.

6.2.5 Windows

Windows are vital elements in construction because they provide ventilation, natural light, views, and a connection to the outside world in addition to significantly improving the health, comfort, and productivity of a building's occupants. Drafty, inefficient, poorly insulated, or simply poorly chosen windows can present a major source of unwanted heat loss, discomfort, and condensation and thus compromise the energy efficiency of a building's envelope. Window manufacture whether made of aluminum, plastic, steel, or wood will require energy and will likely generate air pollution. Energy efficiency is one of the main considerations in reducing

the environmental impacts of a window, followed by waste generated in manufacturing and general durability. However, these negative aspects have largely been addressed by modern technology. Fig. 6.5 shows the various components of a window. According to Gregg D. Ander, FAIA, “In recent years, windows have undergone a technological revolution. High-performance, energy-efficient window and glazing systems are now available that can dramatically cut energy consumption and pollution sources: they have lower heat loss, less air leakage, and warmer window surfaces that improve comfort and minimize condensation. These high-performance windows feature double or triple glazing, specialized transparent coatings, insulating gas sandwiched between panes, and improved frames. All of these features reduce heat transfer, thereby cutting the energy lost through windows.”

Windows come in a variety of glazing options. Each option offers a different thermal resistance or R-value. R-Values are a thermal resistance measure that is used in the building industry. A high R-value indicates that the window has a greater resistance to heat flow and a higher insulating value than a window with a low R-value. It should be noted that R-values are approximate and vary with temperature, type of coating, type of glass, and distance between glazings. R-value is the inverse value of the U-factor ($R = 1/U$) and is expressed in units of hr-sq ft-°F/Btu. U-value gives you the rate of heat flow due to conduction, convection, and radiation through

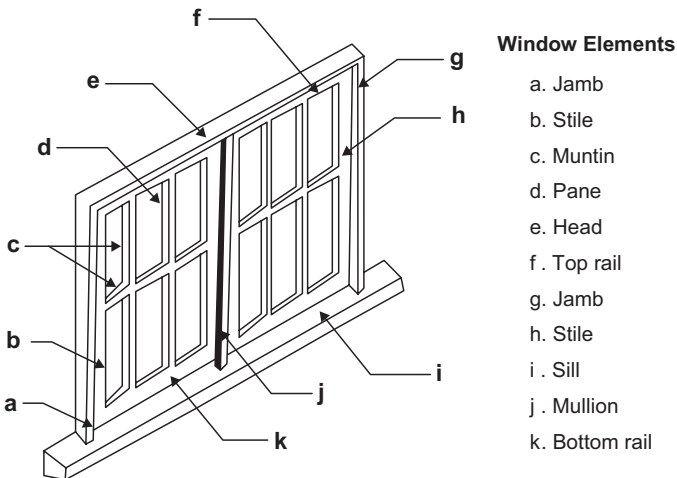

Figure 6.5 Drawing of a window showing individual elements.

a window resulting from a temperature difference between the interior and exterior. The higher the U-factor, the more heat is transferred (lost) through the window. Below are typical examples of R-values from lowest to greatest resistance:

- Single glazing and acrylic single glazing are similar; $R = 1.0$.
- Single glazing with a storm window and double glazing are similar: $R = 2.0$.
- Double glazing with a low-E coating and triple glazing are similar: $R = 3.0$.
- Triple glazing with a low-E coating: $R = 4.0$.

It is interesting to note that for a conventional insulated stud wall $R = 14.0$.

Residential window frames are typically made from aluminum, wood, vinyl, or fiberglass, or combinations of wood and aluminum or vinyl (i.e., “clad”). Older, single-pane windows rarely perform as well as new windows and should preferably be reused only in unheated structures such as greenhouses or barns. Each material has a different cost, insulating ability, and durability, as shown below:

- Wood is a natural material that requires continuous maintenance (stain or paint) for durability. Likewise, the wood source should be certified by an accredited organization such as the FSC.
- Fiberglass is energy intensive to manufacture but is strong and durable and has excellent insulation value.
- Aluminum and steel are poor insulators and very energy intensive to manufacture. Also, over time, aluminum will oxidize leaving a dull pitted appearance. When using metal-framed windows, look for recycled content and frames insulated with “thermal breaks” to limit the loss of heat to the exterior.
- Vinyl is a product of the plastics industry, offers good insulation but is highly toxic in its manufacture and if burned. Vinyl windows are usually nonpaintable but do offer a lifetime free maintenance. High-efficiency windows typically utilize dual or triple panes with low-E (low emissivity) coatings and gas fill (typically argon) between panes to help control heat gain and loss. Factory-applied low-E coatings on internal glass surfaces are more durable and effective than films. High-quality, efficient windows are widely available from local retailers. To make an informed choice, consider only windows that have National Fenestration Rating Council (NFRC) ratings (see sidebar). The EPA ENERGY STAR label for windows can be a useful summary of these factors.

Factors That Can Impact the Full Frame R-Value of a Window

- Type of glazing material used (e.g., glass, transparent coatings, suspended film, treated glass, single, double or triple glazing).
- The number of air chambers created by multiple layers of suspended film or glass panes.
- Type of gas (e.g., argon), if any, is used to fill the air space(s).
- Air and water “tightness” of the window can significantly affect a window’s performance.
- The thermal resistance and attributes of the frame and spacer materials affect a window’s performance.

The NFRC is a nonprofit, public/private organization created by the window, door, and skylight industry and is composed of manufacturers, suppliers, researchers, architects and designers, code officials, utilities, and government agencies. The NFRC has developed a window energy rating system based on whole product performance and provides performance ratings in five categories. They are:

- The U-factor is a measure of a window’s ability to keep heat inside or outside a building. U-factor values generally range from 0.25 to 1.25 and are measured in $\text{Btu}/\text{h}\cdot\text{ft}^2\cdot^\circ\text{F}$. The lower the U-factor, the better the window insulates. Values of 0.4 or lower are recommended.
- The solar heat-gain coefficient (SHGC) summarizes a window’s capability to block heat caused by sunlight. SHGC is measured on a scale of 0–1; values typically range from 0.25 to 0.80. The lower the SHGC, the less solar heat the window transmits. SHGC values of less than 0.4 are preferable.
- Visible-light transmittance (VLT) measures the amount of light the window lets through a window. Desired VLT varies with taste and application. VLT is measured on a scale of 0–1; values generally range from 0.20 to 0.80. The higher the VLT, the more light you can see.
- Condensation Resistance measures how well the window resists water buildup. It is scored on a scale from 0 to 100. The higher the condensation resistance, the better. Condensation can contribute to mold growth, although new, high-quality windows (with a low U-factor) are generally better equipped to resist condensation than older windows.
- Air Leakage (AL) measures the rate at which air passes through joints in the window. AL is measured in cubic feet of air passing through one square foot of window area per minute. The lower the AL value, the less AL. Most industry standards and building codes require an AL of $0.3\text{ cf}\cdot\text{m}/\text{ft}^2$.

6.2.6 Miscellaneous Building Elements

Gypsum Wall Board (Drywall)

Gypsum board is the most common indoor building material in the United States. In the United States and Canada, gypsum board is manufactured to comply with ASTM Specification C 1396 which was designed to replace several existing ASTM specifications, leaving one reference standard for all gypsum board products. This standard is to be applied whether the core consists of natural ore or synthetic gypsum.

Gypsum wall board, also known as drywall, or plasterboard is a plaster-based wall finish that is available in a variety of standard sizes; 4 ft wide by 8 ft high is the most common. Thicknesses vary in 1/8-inch increments from 1/4 to 3/4 inch. Gypsum wall board, which is also known by its proprietary names Drywall and Sheetrock, is ubiquitous in construction. Gypsum wall board is a benign substance (basically paper-covered calcium sulfate), but it has significant environmental impacts because it is used on a vast scale; domestic construction uses an estimated 30 billion square feet per year. Advantages of gypsum board include its low cost, ease of installation and finishing, fire resistance, nontoxicity, sound attenuation, and availability. Disadvantages include: difficulty in curved-surface application and low durability when subject to damage from impact or abrasion.

Gypsum board manufacturers are increasingly relying on “synthetic” gypsum as an effective alternative to natural gypsum. It is estimated that roughly 45% of the gypsum used by U.S. manufacturers in 2010 was of the synthetic variety. Synthetic gypsum and natural gypsum have similar general chemical compositions ($\text{CaSO}_4 \cdot 2\text{H}_2\text{O}$). The vast majority of the synthetic gypsum used by the industry is a by-product of the process used to remove pollutants from the exhaust created by the burning of fossil fuels for power generation. If synthetic gypsum was not used to manufacture gypsum panel products, it would end up in landfills.

Though synthetic gypsum-board use is growing in popularity, and reclaimed gypsum board can easily be recycled into new gypsum panels that conform to the same quality standards as natural and synthetic gypsum, doing this may not be practical because gypsum is an inexpensive material which can require significant labor to separate and prepare for recycling. Gypsum-board face paper is nearly 100% recycled from newsprint, cardboard, and other postconsumer waste streams, but most recycled gypsum in wall-board products is postindustrial, made from gypsum-board manufacture.

Ecology Action, a nonprofit environmental consultancy states that the main environmental impacts of gypsum include habitat disruption from mining, energy use and associated emissions in processing and shipment, in addition to solid waste from disposal. Some of these impacts can be significantly reduced by the use of “synthetic” or recycled gypsum board. Synthetic gypsum, which is now used in about 30% of drywall, is a by-product of coal-fired power plants. It is sometimes confused with fly ash another coal combustion product with which it has very little in common. In excess of 80% of coal fly ash sold in the United States is used in gypsum board.

New technologies have helped in the development of several new Gypsum board products that have come on the market and that are more environmentally friendly and superior in many ways to the traditional gypsum board. One such example is the new ecofriendly EcoRock Drywall which has significantly changed and improved the drywall product from its basic material elements to its production processing methods. EcoRock is a fully recyclable and highly attractive alternative. It is manufactured from 80% postindustrial recycling and exploits material from steel and cement plant waste and can be safely discarded in landfills. EcoRock is naturally cured and dried, which means that 80% less energy is required than the traditional methods use in the manufacturing process. Moreover, it contains no gypsum, thus eliminating the need for high-intense energy consumption during production and improves air quality by eliminating airborne mercury. EcoRock drywall, which creates 60% less dust, is resistant to termites and is 50% more resistant to mildew and mold.

Siding

Siding is the external covering or cladding applied to the outermost surface of an exterior wall with the main function of providing protection from adverse effects of extreme weather, moisture and excess water, the heat and ultraviolet radiation of the sun. There are many types of siding materials that one can choose from, such as plastic (vinyl) siding, fiber cement siding, wood siding, composite siding, metal siding, and masonry siding to name but a few. Selecting siding that is reclaimed, recyclable, or incorporating recycled material will reduce waste and pollution. However, the environmental impact of a siding product will vary considerably according to the material it is made from.

Siding may be formed of horizontal boards or vertical boards (also known as weatherboarding in some countries), shingles, or sheet materials. In all these cases, avoiding wind and rain infiltration through the joints is a real challenge that is met by overlapping, by covering or sealing the joint, or alternatively

by creating an interlocking joint (such as a tongue-and-groove or rabbet). Creating rigid joints between the siding elements is not practical because materials will contract or expand according to the changing temperature and humidity. Moreover, siding may be attached directly to the building structure (studs in the case of wood construction) or to an intermediate layer of horizontal planks called sheathing. There are many types of siding including:

Vinyl siding is made from a PVC plastic and is very widely used. Unlike wood or cedar, it would not rot or flake. Vinyl siding has grown in popularity because it requires little maintenance and is generally less costly to purchase and install than most other siding materials. The main drawbacks of vinyl are that it cracks, fades, and grows dingy over time. It is also controversial because of environmental concerns.

Earth or lime plasters may last a long time and do not require much maintenance. Cement or lime is commonly added to improve its hardening and durability attributes, but the relatively low (or zero) overall cement content of natural plasters means that the material requires relatively small amounts of pollution and energy use to prepare and install. Deep eaves or overhangs are often needed to protect the siding from extended moisture exposure and which are critical to the extending the natural plaster's useful life.

Fiber cement siding has proven to be extremely durable, in addition to many products being backed by 50-year or lifetime warranties. The siding is made from cement, sand, and cellulose fiber. In addition to its improved ecofriendliness, fiber cement siding also comes with a lower price tag than other materials. Moreover, it is fire resistant and pest resistant and emits no pollutants in use. However, it does possess a high embodied energy due to its cement content.

Quality cement stucco is another alternative material that can be extremely durable, which helps minimize long-term waste, but it is also energy intensive to manufacture. Cement substitutes such as fly ash or rice-hull ash can mitigate the environmental cost of stuccos.

Metal siding comes in a variety of metals, styles, and colors. It is very durable and recyclable and typically contains significant postconsumer recycled content. It is generally energy intensive to manufacture, although recycled steel and aluminum require far less energy than virgin ore. Metal siding is most often associated with modern, industrial, and retro buildings. Utilitarian buildings often use corrugated galvanized steel sheet siding or cladding, and corrugated aluminum cladding is common where a more durable finish is required.

Composite siding such as hardboard is made of newspaper or wood fiber mixed with recycled plastic or binding agents. It is highly durable and generally resists moisture and decay. It also often has significant recycled

content and is not prone to warping or cracking like wood. Composites generally do not require frequent repainting, and some need not be painted at all, saving waste and valuable resources.

Wood siding is one of the oldest types of siding and is popular in old and historic homes. Wood siding's main disadvantage is that it requires more maintenance (polishing and painting) than many of the other siding options. If it is not well maintained, wood can easily be the least durable option, generating significant waste. Wood siding is also more vulnerable to warping, splitting, and damage by insects and termites. Among its positive attributes is that it is renewable and requires relatively little energy to harvest and process. Wood siding can also be made of unpainted weather-resistant woods such as redwood.

As with most green products, selecting the most appropriate green siding is often a matter of weighing trade-offs in longevity, biodegradability, insulation, maintenance, and, sometimes, cost. Final selection will also depend largely on your objectives and requiring you to prioritize which attributes will best meet these objectives. Such considerations should include:

- Selecting the most durable siding product that is appropriate. Siding failures that allow water into the wall cavity can lead to expensive repairs, the waste of damaged components, and the environmental costs of replacement materials. Fire resistance is a feature that helps reduce the financial and environmental impact of rebuilding, particularly in high-risk areas.
- For existing buildings, consideration should be given to refinishing existing siding to minimize waste, pollution, and energy use.
- Preference should be given to selecting materials that are biodegradable, have recycled content, and/or are recyclable.
- Reclaimed or remilled wood siding should be used to reduce demand for virgin wood and waste. Painted wood should be tested for lead contamination prior to use.
- New wood siding should display an FSC-certified label.
- Although vinyl is durable, it is not considered a green building material. Attributed disadvantages include pollution generated in manufacturing, air emissions, human health hazards of manufacturing and installation, the release of dioxin and other toxic persistent organic pollutants in the event of fire, and the difficulty in recycling it.

6.2.7 Roofing

A roof system's primary function is to protect against and manage the weather elements, particularly precipitation, thereby protecting the interior and structural components of a structure from deterioration. There are two

basic types of roof construction, sloped or pitched and flat. Sloped roofs are generally covered with individual pieces of overlapped shingling material to prevent water penetration. Flat roofs are basically watertight membranes that should have just enough of a slope to allow water to run off. Flat roofs are more popular in hot arid climates, particularly in developing countries where they are used in the evenings for sleeping, etc. In the United States and Europe, however, flat or low-slope roofs are typically selected when the roof is expected to accommodate rooftop equipment.

The most critical characteristics of roofing materials are moisture/water resistance, dependability, and durability. The development of new materials and processes are needed to minimize creation of new health or environmental safety problems. The transporting and processing of the materials are coming under increasingly strict regulation to protect the health of workers involved in production and distribution. Roofing material extraction, manufacture, transport, and disposal pollute air and water, deplete resources, and damage natural habitats. Roofing materials comprise an estimated 12–15% of C & D waste.

For a roof to be environmentally sustainable, it must be durable and long lasting and ideally also contain recycled or low-impact materials. Roofs that are environmentally friendly can provide several advantages such as aesthetically pleasing design options, reduced life-cycle costs (LCCs), and environmental benefits such as reduced landfill waste, energy use, and impacts from harvesting or mining of virgin materials. It takes roughly the same materials, energy, and labor to manufacture and install a 50-year-warranted roof as a 30-year roof, yet the first option is “greener” because disposal and the roof’s lifetime cycles are extended, thereby providing a better investment. Moreover, a properly installed 50+ rated roof can reduce roofing waste by 80–90% over its lifetime, relative to a roof with a warranty of only 20 years.

Normally, mild climates are better suited for passive temperature controls that reduce winter heating and reduce or eliminate the need for mechanical cooling. The need for air conditioning is generally less in mild climates because operable windows and skylights are often employed that can easily provide ventilation and cooling, particularly in smaller buildings. But even larger commercial buildings can be cooled effectively in mild climates without the use of air conditioning providing care is taken in the initial design, and the design of the roofing structure minimizes heat gain. And although cool roofing does not renew resources, it is often a highly cost-effective way to conserve them. Likewise, electricity from solar photovoltaic panels reduces demand for fossil fuels and is therefore environmentally friendly.

Choosing Roofing Materials

Choosing the right roofing materials requires taking into consideration numerous factors, including climate and weather conditions in the project area, the roof's lifespan expectancy, budget, aesthetic preferences, and various sustainability factors. Some primary considerations that could impact the type of roof to be chosen include:

- Roof's ability to resist heat flow from the roof into the interior, whether through insulation, radiant barriers (highly reflective material that inhibits heat transfer by thermal radiation), or both.
- Roof's capacity to reflect sunlight and reemit surface heat. Cool roofs can reduce cooling loads and urban heat-island effects while extending roof life.
- Roof's ability to reduce ambient roof air temperatures through evaporation and shading, as in the case of vegetated green roofs.
- Roof's recyclability and/or capability of being reusable at the end of its useful life to minimize waste, pollution, and resource use. Roofs with high postconsumer recycled content (up to 30%) are preferable.
- Look for nonhalogenated fire-retardant roofing membranes (i.e., materials that do not contain bromine or chlorine) that meet fire code requirements. Burning of PVC and thermoplastic olefin (TPO) produces strong acids and persistent toxic organic pollution, such as dioxin.

For local fire codes compliance, the roof may require protective ballast such as concrete tile. Existing PVC and TPO roofing membranes, as well as underlying polystyrene (PS) insulation, are increasingly being recycled as federal construction-specification requirements generate increased demand in the industry. The following are some of the roofing options for residential and commercial applications:

- Clay or cement tiles are very durable and made from abundant materials, but they are heavy and expensive. Ensure that structure can take additional weight.
- Recycled plastic, rubber, or wood composite shingles are generally durable, lightweight, and sometimes recyclable but they are not biodegradable.
- Composition shingles are very popular and typically have a lifetime of 15–30 years although some manufacturers offer up to 50-year warranties. The composition shingle has a fiberglass mat core which gives the shingle flexibility and provides some fire resistance. The exterior of the composition shingle has a weather-resistant asphalt coating embedded with crushed rock. Composition shingle roofs can be recycled but are susceptible to algae growth unless an antialgae coating is applied.
- Fiber cement is durable and fire- and insect proof but is heavy and not renewable or biodegradable but may be used as inert fill at demolition.

- Metal (e.g., aluminum, steel) is a durable, fire- and insect proof recyclable material. It typically contains recycled content, but manufacture is generally energy intensive and causes pollution and habitat destruction.
- Built-up roofs are said to have a track record exceeding 150 years, but their durability depends largely on the structure, installation, flashing, and membrane chosen. Also, most membranes are not made from renewable resources, although some may contain recycled content. Although built-up roofs are highly reliable, their market share has declined significantly over recent decades mainly due to the increasing cost of tar. Of note, high-VOC products emit air pollution during installation.
- Vegetated green roofs are most commonly installed on low-pitched roofs (at least one inch of rise for every foot of run, to facilitate drainage). Green roofs help reduce the negative aspects of conventional roofing, while adding green space to the property.
- Wood shakes have a rustic appearance and are biodegradable, but they are also flammable and not very durable. Wood shakes are not typically considered to be a “green” option for areas that are fire prone.

New technologies continue to emerge that encourage the promotion of sustainability/green building and green roofs, because green roofs offer many economic, social, and environmental benefits. Today we are witnessing increasing efforts to make usable space on existing rooftops and/or new roofs to allow additional living space (Fig. 6.6). Green or “living” roofing which involves the use of vegetation as the weathering



Figure 6.6 Example of a 70,000-square-foot vegetated roof on the LDS Assembly Hall building, Salt Lake City, UT. Source: American Hydrotech, Inc.

surface has proved very successful because it helps reduce extremes in rooftop temperature that shorten the life of a roof (leading to increased C & D waste), conserves energy, and extends the useful life of the roof. An important factor in creating these spaces is the need to use lightweight and recycled materials and to help with managing storm water run-off because traditional drainage systems using pipe and stone are not plausible. Green roof systems are a natural and cost-effective way of providing additional clean air through the transference of CO₂ and oxygen between the plants and vegetation and the atmosphere, thereby helping to control urban air pollution.

The main reasons that Green roofing has proven to be effective is that the large surface area of soil and plants helps to reradiate heat; it also provides shade and insulation for the waterproof roof membrane, while the plants' transpiration provides cooling. The net result of this is a 25- to 80-degree decrease in peak roof temperature and a much reduced cooling-energy demand (up to 75%). Cooler roof temperatures will also reduce the urban heat-island effect and thus help reduce the cooling load for surrounding buildings.

In addition to the environmental benefits, green roofs provide aesthetic and cost benefits (as well as benefiting local property values). The soil and vegetation in many common designs can retain up to 75% of a one-inch rainfall and will filter the remainder. This on-site storm-water management helps reduce demand on storm-water infrastructure, saving resources and money for the entire community. To help address this issue, New York City property owners are assessed a tax based on the volume of storm water run-off, whereas, they are offered a tax reduction if the building has a green roof. Green roofs can often facilitate urban wildlife microhabitat. Although not a replacement for wild land, a vegetated roof can accommodate birds, beneficial insects, and native plants far better than tar and gravel. Contemporary green-roof designs generally contain a mixture of hard and soft landscaping. It is very important therefore that the selected drainage/retention layer is capable of supporting any type of landscape from roadways and paths to soil and trees so as to permit excess water to drain unobstructed underneath as shown in [Fig. 6.7a-c](#).

Green roof systems generally contain certain essential layers and components to be viable. The main layers generally consist of: vegetation; soil; filter and a waterproofing membrane; root barrier; drainage and irrigation system; roof membrane; and sometimes an insulation layer. AWD, a leader in roof garden and prefabricated drainage systems, notes that the main components,

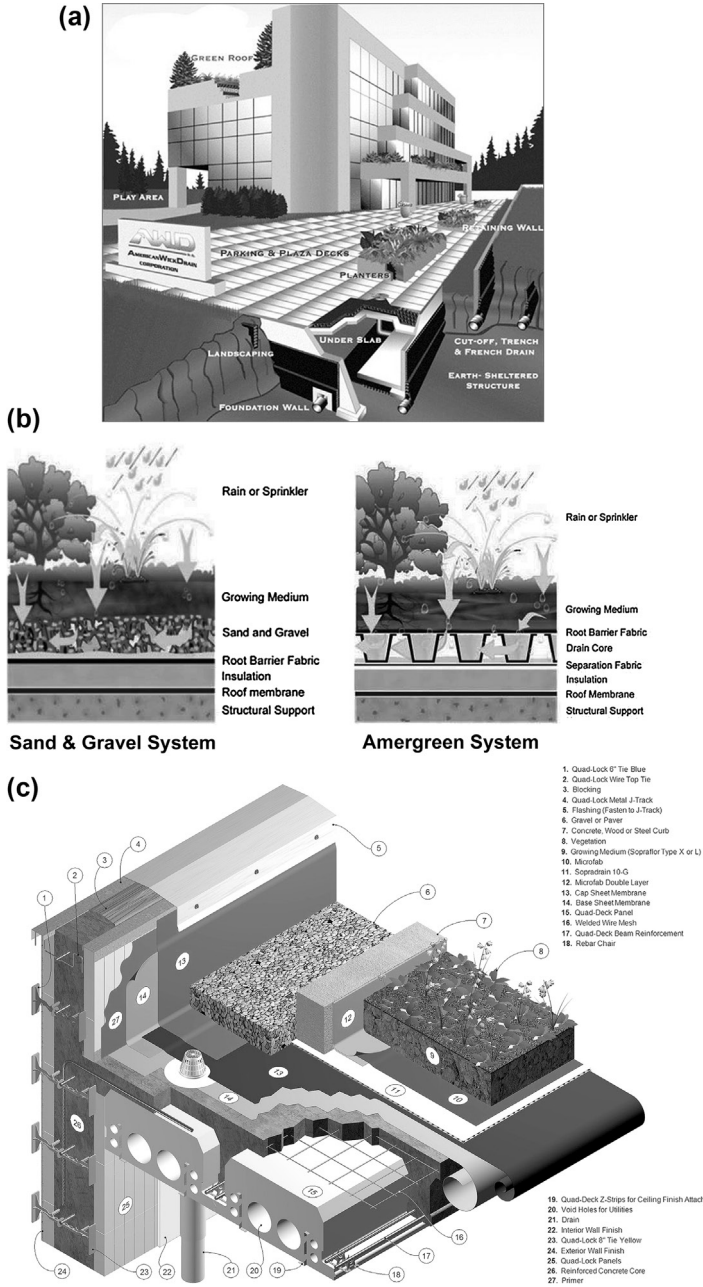

Figure 6.7 (a) Rendering showing commercial application of green elements. (b) Drawing showing two types of roofing systems: sand and gravel system and the Amergreen roofing system. (c) Drawing of a Quad-lock roofing system detail. (a, b) Source: American Wick Drain Corporation; (c) Source: Quad-lock Insulating Concrete Forms.

materials, and locations to take into consideration when contemplating the installation of a green or vegetated roof are:

- **Structural support:** Roof and roof garden systems are required to have an underlying structural system in place to support additional weights resulting from use of normal building materials such as concrete, wood, etc. The structural engineer needs to consider the load of the roof-garden system in the initial design phase.
- **Roofing membrane:** The design engineer has a number of roofing membrane options available at his/her disposal. The final membrane choice may be decided by several factors such as loads imposed by the rooftop garden, by available membrane protection elements in the rooftop-garden system, by root penetration properties of the membrane, and by membrane drainage and aeration requirements.
- **Membrane protection:** The roofing membrane may require protection from installation damage, long-term water exposure, UV exposure, drainage-medium loads, chemical properties, or growing-medium loads.
- **Root barrier:** A root barrier filter fabric may be required between the growing medium and the lower components to allow excess water in the growing medium to drain while preventing small particles in the growing medium from moving into drain core. It may also be needed to eliminate or mitigate potential root penetration into the roofing membrane, drainage medium, or water-storage medium. The optimum location is above the membrane, drainage medium, and water-storage medium so that all three components are protected. Alternate locations may require multiple roof-guard elements to avoid long-term root penetration. While some systems have the root barrier placed under the drainage layer, AMERGREEN, for example, who specialize in green roofs, states that it designs the root barrier “at the most effective location for system performance—above the drainage layer and in direct contact with the soil medium”. Some roofs do not incorporate a specific insulation layer unless a higher insulation is required. Insulation (usually based on a rigid synthetic board foam) may be installed above the structural support, depending on the thermal design of the structure. Insulation may also be installed above or below the roofing membrane whichever proves more effective.
- **Drainage medium:** An appropriate drainage medium is required to ensure the proper range of water content in the growing medium. An excess of water can have an adverse effect and cause root rot. Insufficient water can result in poor vegetation growth. There are various drainage-medium

options ranging from gravel to materials designed specifically for this purpose. Plastic materials usually combine the drainage function with water storage and aeration in addition to protecting the membrane from roots and potentially damaging materials in the growing medium.

- **Aeration:** It is a vital element to promote optimal vegetation growth. The aeration medium usually serves as both drainage and aeration medium. The open channels incorporated in the prefabricated drain core are designed to provide necessary air to the plant roots.
- **Growing medium:** There are a number of natural and manufactured materials that may be used as a growing medium. Soil is often mixed with other materials to reduce weight, to provide better structure for roots, as well as to provide essential nutrients, oxygen, and water.
- **Water storage:** While the growing medium will store a certain quantity of water, additional water storage may be required to provide more efficient growth of vegetation. Most prefabricated plastic roof-garden products have water-storage capability. The plastic cones of the prefabricated core provide positive water-storage reservoirs. Likewise, sand and gravel may hold a certain amount of water.
- **Vegetation:** This provides the upper and most visible layer of the roof-garden system. There is a wide variety of typical landscaping and garden plants that may be employed for a rooftop garden. An experienced landscape architect should preferably be involved in plant selection to ensure that the vegetation chosen is appropriate both for the geographic region and for a rooftop-garden environment. Moreover, careful consideration should be given to the type of vegetation chosen as this will inevitably affect the selection of other components of the roof-garden system such as root protection, water and aeration needs, and drainage requirements—all of which are affected by plant selection.

Extensive and Intensive Green Roofs

There are basically two primary categories of green roofs—extensive or intensive—although a green roof is frequently designed to contain features of both and are then referred to as a semiextensive or semiintensive green roof (sometimes spelled *greenroof*). The roof's function or objective of the roof space usually determines the final design—e.g., whether it is intended as an ecological cover or whether it is intended for human recreation, vegetable gardening, etc.

Extensive green roofs (sometimes called ecoroofs or low-profile roofs) typically contain a layer of soil medium that is relatively thin (two to six

inches) and lightweight (weighs 10 to 50 pounds per square foot for the entire system when fully saturated with water). They are lightweight, relatively easy to install, durable, require very low maintenance, and cost effective. Extensive green roofs are usually built when the main goal is for an ecological roof cover with limited human access. Ideal plants for this type of roof are low growing, horizontally spreading root ground covers, having a general maximum plant height of 16–24 inches. Alpine-type plants are typically successful because they have the necessary attributes for green roofs including high drought, wind, frost, and heat tolerance. Appropriate plants include sedums and other succulents, flowering herbs, and certain types of grass.

Intensive green roofs (sometimes called high profile) often look like traditional roof gardens because they are designed to accommodate trees and gardens. Soil can be as deep as needed to accommodate the desired tree or plant species, but deeper, denser soil dramatically increases dead load, requiring a stronger and more expensive structure, greater maintenance, and either terracing or a relatively flat roof. The engineered soil media for an intensive green roof usually contains about 45–50% organic material to 50–55% mineral material and when fully saturated with water, weighs between about 80 and 120 lbs/sq. ft. or more. The inclusion of architectural and decorative elements such as waterfalls, ponds, gazebos, etc. are possible, and these green roofs provide recreation spaces and encourage interaction between nature and a building's occupants. It should be noted that there are green-roof options available for almost any building type or location. Among the many benefits attributed to green roofs include:

- They provide greater insulation and more moderate rooftop temperatures, which reduce cooling and heating requirements, saving energy and money. Research by the National Research Council of Canada found that extensive green roofs reduced the daily energy demand for air conditioning in the summer by over 75% (Liu, 2003).
- They are considered a best practice because they facilitate filtration and detention of storm water, reducing pollution and the cost of new and expanded infrastructure as paved areas increase. Green roofs can reduce the amount of storm water runoff volume to sewer systems by 50–90% and peak storm water runoff flow by 75–90% resulting in decreased stress on sewer systems at peak flow periods. By comparison, a typical roof will retain 10% of storm water runoff.
- They naturally absorb dust and filter harmful particulates and airborne pollutants. They also have superior noise attenuation, especially for low-frequency sounds. An extensive green roof, for example, can reduce

sound from outside by 40 decibels, while an intensive one can reduce sound by 46–50 decibels (Peck et al., 1999).

- They are an effective fire retardant. Green roofs generally have a much lower burning heat load (the heat generated when a substance burns) than do conventional roofs.
- They reduce ambient air temperatures, lowering urban heat-island effects and helping to enhance microclimate of surrounding areas, because one of plants' natural functions is to cool the air through the release of water through plants into the atmosphere.
- They extend the life of roof membranes, by decreasing exposure to large temperature fluctuations that can cause microtearing and protect the roof from ultraviolet radiation, extreme temperatures, and mechanical damage. Plant species, soil depth, and root-resistant layers are carefully matched to ensure that the roof membrane is not damaged by the roots themselves.
- Lightweight extensive systems can be designed with dead loads comparable to standard low-slope roofing ballast. Structural reinforcement may not be necessary, and cost can be comparable to conventional high-quality roofing options.
- Can increase a building's marketability, resulting in higher rents and increased resale value. A recent study by UMass Boston estimates that green roofs can increase a property's value by an average of 15%. Green roofs can also facilitate employee recruiting and decreases employee and tenant turnover.
- They can transform rooftop eyesores into attractive assets.

6.2.8 Wood

There are thousands of species of wood, which can probably best be separated into two broad categories: hardwoods and softwoods.

Wood Types

The distinction between hardwood and softwood is botanical, rather than referring to the strength or hardness of the wood. "Hardwood" is a term generally applied to trees that lose their leaves in winter, whereas "Softwood" generally describes evergreens such as pine and redwood. It should be noted that hardwoods are not necessarily hard and softwoods are not necessarily soft (e.g., balsa is a hardwood, and white cypress is very strong softwood). The different types of wood have a multitude of uses and in many cases are interchangeable.

Pressure-treated lumber such as chromated copper arsenate (CCA) pressure treated wood has been popular over the decades partially due to its resistance to rotting, insects, and microbial agents. Existing CCA-treated lumber, however, poses a challenge because arsenic is acutely toxic and carcinogenic and was shown to be leaching into surrounding soils; this prompted it being largely phased out in a cooperative effort between manufacturers and the EPA (effective December 31, 2003). CCA is a chemical wood preservative containing chromium, copper and arsenic. CCA has been classified by the EPA as a restricted use product, i.e., for use only by certified pesticide applicators.

Reuse of CCA pressure treated wood would help conserve forest resources and keep a potentially useful resource out of landfills. Still, permitting its reuse would allow CCA to continue to leach arsenic into soils. CCA-treated wood should not be composted or disposed of in green-waste or wood-waste bins. CCA-treated wood is now mandated to be disposed of in a lined landfill or as class I hazardous waste. The burning of CCA-treated wood is highly toxic. Newer alternative wood treatments which are less toxic, such as copper azole (CA) and alkaline copper quaternary (ACQ), are more corrosive than CCA. To address this, and to minimize rust and prevent staining, manufacturer-recommended fasteners should be employed. The following points should be considered when working with wood products:

- Reuse wood in good condition.
- Repair and/or refinish existing decks, railing, or fencing with nontoxic materials.
- Build with durable materials such as plastic lumber. The composition of plastic lumber varies widely, from 100% postconsumer recycled content to 100% virgin plastic resin.
- The majority of plastic lumber products currently on the market are made from polyethylene although some manufacturers are also employing PS and PVC. In addition, there are some plastic lumber products that rely on a commingled mix of different types of plastics, collected mainly from municipal recycling programs.
- If the structural elements will be in contact with soil and water, consider:
 - Heartwood (the dense inner part of a tree trunk), yielding the hardest timber from decay-resistant species such as redwood or cedar that has been FSC-certified as harvested from a responsibly managed forest.
 - When the use of pressure-treated lumber is required, the two water-resistant preservatives currently employed are CA and ACQ, which are significantly less toxic than CCA.
 - Remaining stocks of CCA should be avoided.

- For fencing, consider ecofriendly alternatives such as a living fence of bushes, shrubs, or live bamboo in urban settings or fencing made of a rapidly renewable material such as cut bamboo.

As wood is a renewable material, it requires less energy than the majority of other materials to process into finished products, as opposed to the significant negative environmental impacts caused by the logging, manufacture, transport, and disposal of wood products. Standard logging practices are known to cause erosion, pollute streams and waterways with sediments, damage sensitive ecosystems, reduce biodiversity, and lead to a loss of soil carbon. These impacts can be reduced by the minimization of wood use through the substitution of suitable alternatives, e.g., reusing salvaged wood, selecting wood from responsibly managed forests, controlling waste, and minimizing redundant components. Where salvaged or reclaimed wood is unavailable or not applicable (e.g., for structural applications), specify products that are certified by an approved and accredited organization such as the FSC.

Engineered lumber (also known as composite wood or man-made wood), consists of a range of derivative wood products that are manufactured by pressing or laminating together the strands, particles, fibers, or veneers of wood with a binding agent to produce a range of different types of building products such as structural framing lumber and trim material. Engineered wood is normally straighter, more stable, and structurally consistent than dimensional lumber. Its superior strength and durability allows it to displace the use of large (and increasingly unavailable), mature timber. In joist and rafter applications, the reconstituted products have proven to be particularly useful because of their ability to span long distances with less sagging than similarly sized conventional lumber. Engineered lumber is also less susceptible to humidity-induced warping than equivalent solid woods, although the majority of particle-based and fiber-based boards require treatment with an appropriate sealant or paint to prevent possible water penetration.

There are numerous applications for engineered products. Generally, they are products that are engineered to meet precise application-specific design specifications and are tested to meet national or international standards. Employing engineered lumber instead of large-dimension rafters, joists, trusses, and posts can save money and reduce total wood use by up to 35%. Engineered lumber also allows for wider spacing of members, which in turn allows for increasing the insulated portion of walls. Other advantages include its ability to form large panels from fibers taken from

small-diameter trees, small pieces of wood, and wood that has defects; these panels can be used in many engineered-wood products, especially particle-based and fiber-based boards. Engineered-wood products are used in a number of ways, usually in applications similar to solid wood products, but many builders prefer engineered products because they are economical and typically longer, stronger, straighter, more durable, and lighter than comparable solid lumber.

Engineered-wood products also have several disadvantages in comparison to dimensional lumber; for example, they require more primary energy for their manufacture than solid lumber. They are also less fire resistant and have adhesives that can potentially release toxins into the environment, as well as being prone to moisture damage. An expressed concern with some resins is the release of formaldehyde in the finished product, often seen with urea-formaldehyde-bonded products. Working with engineered wood products can therefore potentially expose workers to toxic constituents that could cause harm. The applications of engineered wood products are varied and include being used as columns, beams, joists, girders, rafters, studs, and bracing. Although engineered wood is generally more expensive than dimensional lumber, the cost can be offset to some degree by labor savings and improved quality of the product.

Wood adhesives have been important in helping use timber resources efficiently. The main function of an adhesive is to bond wood components such as veneer, particles, strands, and fibers, etc. Moreover, an adhesive must provide the necessary strength immediately following manufacture as well as after long-term use. Prior to the introduction of synthetic adhesives in the 1930s, the adhesives used for bonding wood were generally made from natural polymers found in plants and animals.

Today, natural adhesives continue to being used (but to a much lesser extent) in some nonstructural products; they do not provide the necessary strength and durability required for many of today's engineered wood products. To address the needs of contemporary engineered wood products, polymer scientists have developed various types of synthetic adhesives that are designed to perform a variety of functions in product applications. These man-made polymers resemble natural resins in physical characteristics, but they can be tailored to meet specific woodworking requirements. The choice of an adhesive is determined by several factors; these include cost, structural performance, moisture resistance, fire performance, adhesive curing needs, etc. Generally, there are two primary categories of adhesives currently employed in engineered wood; the first category is for structural

products, and the second is for interior nonstructural products. This first group of resins includes:

- Phenolic (also called phenol formaldehyde or PF), which has a yellow/brown or dark reddish color and is available as liquid and powder or in film form. It is commonly used for exterior exposure products and used to produce softwood plywood for severe service conditions.
- Resorcinol, which is purple in color and waterproof/boil proof, is typically used for structural wood beams.
- Melamine-formaldehyde resin, which is white in color, heat- and water-resistant, and preferred for exposed surfaces in more costly designs. Its use is limited to a few special applications such as marine plywood where the need for a light-colored water-resistant adhesive justifies its cost.
- Methylene diphenyl diisocyanate (MDI) which is an aromatic diisocyanate, although not benign, is the least hazardous of the commonly available isocyanates. It is generally expensive, waterproof, and does not contain formaldehyde.
- Polyurethane (PU) resin, which MDI is also generally expensive, waterproof, and does not contain formaldehyde. It is used largely in the sphere of coatings and adhesives because of its high reactivity, high flexibility in formulation and application technologies, adhesion and mechanical properties, and resistance to adverse weather.

Typical examples of structural products include OSB, plywood, end-jointed lumber, glued laminated timber (glulam), I-joists, and structural composite lumber. The second group of adhesives includes adhesives formulated from materials of natural origin such as animal, vegetable, casein, and blood glues. They lack the temperature capabilities or environmental durability evidenced by structural adhesives. Nevertheless, they generally provide an instantaneous bond due to their pressure sensitive or hot melt characteristic. Nonstructural adhesives are generally used for interior applications, although many new products are also seeing exterior applications as well. Nonstructural adhesives also include adhesives such as urea formaldehyde resin (UF), which is widely used for the manufacture of interior grade plywood and also for the manufacture of particleboard. It is considered to be the most widely used thermosetting resin for wood, which although not waterproof, is, nevertheless, popular because it is inexpensive. Moreover, the low resistance to heat and moisture of these adhesives makes their use appropriate for indoor, nonstructural wood products.

Sheathing is the structural covering of plywood or oriented strand board (OSB) that is applied to studs and roof/floor joists to provide shear strength

and serve as a base for finish flooring or a building's weatherproof exterior. Sheathing is considered to be the second most wood-intensive element of wood-frame construction. Exterior Gypsum Sheathing comes in various sizes including a 1/2" thick, 2' wide with a tongue-and-groove edge or, 1/2" & 5/8" thick, 4' wide square edge product. 5/8" Exterior Gypsum Sheathing has a Type X core, for use in fire-rated assemblies. Engineered-wood sheathing materials do have some environmental tradeoffs because the wood fibers are typically bound with formaldehyde-based resins. Interior-grade plywood typically contains UF, which is less chemically stable than the PF found in water-resistant exterior-grade plywood and OSB. This advantage makes exterior-grade plywood preferable for indoor applications, as it emits less toxic and suspected carcinogenic compounds.

There are numerous alternatives to these wood-intensive conventional and engineered materials. For example, fiberboard products rated for structural applications (such as Homasote, a 100-percent-recycled nailable structural board) are considered alternatives to plywood and OSB. Structural-grade fiber-cement composite siding combines sheathing and cladding, providing shear strength and protection from the elements while reducing labor costs for installation. It is promoted as being ecofriendly because it requires fewer trees, would not burn, would not rot, extends the life of a paint job, and usually is warranted for 50 years.

This product is relatively new but has become increasingly popular since its introduction, in part because it can be manufactured to have the realistic appearance of wood, stucco, or masonry. Its main drawback, however, is that it is heavy to lift, and its installation requires specialized cutting tools. Water-resistant exterior-grade gypsum sheathing is one of the options that can be employed as an underlayment for various exterior siding materials such as wood, stucco, metal or vinyl siding, masonry veneer, etc., to reduce wood requirements. The panel is manufactured with a wax-treated, water-resistant core faced with water-repellent paper on the face and back surfaces as well as on the long edges. Structural insulated-panel construction provides interior and exterior sheathing as well as insulation in precut, factory-made panels. And by designing for disassembly, sheathing materials can be readily reused or recycled. Also, designs that combine bracing with nonstructural sheathing can provide necessary strength while increasing insulation and reducing wood requirements. Medium-density fiberboard (MDF) is an engineered composite wood product that is nonstructural and somewhat similar to particleboard. MDF is one of the most rapidly growing composite board products to enter the market in recent years. It typically consists of low-value wood by-products

such as sawdust combined with a synthetic resin such as UF or other suitable bonding system and joined together under heat and pressure. Additives are often introduced during the manufacturing process to impart additional characteristics. MDF panels are therefore manufactured with a variety of physical properties and dimensions that allow the end product to be designed with the specific characteristics and density needed. MDF is widely employed in the manufacture of furniture, kitchen cabinets, laminate flooring, paneling, door parts, shelving, millwork, and moldings. Generally, it can provide an excellent substitute for solid wood in many applications, except when the stiffness of solid wood is needed.

MDF can be dangerous to use if the correct safety precautions are not taken. MDF contains UF, which may be released from the material through cutting, and sanding, and which may cause irritation to the eyes and lungs. It is necessary therefore to have proper ventilation when using it, and facemasks are needed when cutting or sanding MDF with machinery because the dust produced can be very dangerous. And although MDF is highly toxic to manufacture, it does not emit VOCs in use. MDF will accept a wide variety of sealers, primers, and coatings to produce a hard, durable tool surface, but it is not suitable for high-temperature applications. MDF-type panels can also be made using waste wood fiber from demolition wood and waste paper.

The properties of MDF will likely vary from country to country and region to region, based on where it is produced; thus the properties of MDF board produced in China will likely differ from MDF boards produced in Romania or Indonesia. MDF also comes in several densities depending on the intended application. The surface of MDF is generally flat, smooth, uniform, dense, and free of knots and grain patterns. The homogenous density profile of MDF allows intricate and precise machining and finishing techniques for superior finished products. Trim waste is significantly reduced when using MDF compared to other substrates. Stability and strength are important attributes of MDF, which can be machined into complex and delicate patterns that require precise tolerances. Moreover, its smooth surfaces also make MDF an excellent base for veneers and laminate applications.

Some of the current environmental pollution problems are created by burning and dumping of agricultural residues and, together with concern for the conservation of future forest resources, have generated considerable interest in finding suitable outlets to utilize the large amounts of crop residues being produced annually. And because agricultural residues are abundant and renewable annually, it became evident that they are excellent alternative sources to replace wood and wood fiber. Increasing constraints on residue burning have also been

a prime motivator for their introduction. This new environmentally friendly technology for turning agricultural residues into ecofriendly boards entails compressing the agricultural residue materials with nonformaldehyde glues; the panels provide an excellent alternative to plywood sheets 3/8 inch and thicker and can be used in much the same way as MDF. They can also replace OSB and MDF for interior walls and partitions work.

Agricultural-residue (ag-res) boards are made from waste wheat straw, rice straw, jute, coconut coirs, bagasse, cotton stalks, casuarina leaves, banana stem, or even sunflower seed husks. Ag boards are aesthetically pleasing, often stronger than MDF and just as functional. Under heat and pressure, microscopic “hooks” on the straws link together, reducing or eliminating the need for binders. The use of new soy adhesives promises both improved performance and economics to the ag-composites industry. They are also expected to be safer to handle and to reduce VOC emissions.

Homasote is a brand name that has become synonymous with the product generically known as cellulose based fiber wall board. It is a panel product made of 100-percent postconsumer recycled newspaper fiber and has actually been in production longer than plywood and OSB (about 100 years). It has many potential fiberboard applications specific to sound control in floors and walls, tackable wall board, fire protection for roof decks, concrete expansion joints, low emission IAQ, and thermal insulation. Homasote is weather resistant, structural, and extremely durable, and it has two to three times the strength of typical light-density wood fiberboards. Furthermore, it is nontoxic, wax emulsified for moisture and mold resistance and integrally protected against termites and fungi, ensuring a healthy environment, conserving natural resources, and reducing solid waste in landfills.

Framing

Advanced framing, or optimum-value engineering (OVE) as it is sometimes referred to, consists of a variety of framing techniques designed to reduce the amount of lumber used and waste generated in the construction of wood-framed structures. This helps reduce material cost and use of natural resources while at the same time increasing energy efficiency by providing more space for insulation. It also helps reduce the processes of extraction and manufacture, as well as transport, and lumber disposal which deplete resources, damage natural habitats, and pollute air and water.

Another problematic issue here is that dimensional lumber supplies depend upon larger trees that need decades to mature. Although OVE framing techniques are accepted by code, for one reason or another, they have

received limited market penetration and acceptance by builders, framers, and consumers (less than one percent of the residential building market), and this is despite the long-term experience and significant resources that continue to support its use. Provisions for several key OVE framing practices can be found in model U.S. building codes (ICC, 2012a,b).

Modern OVE advanced framing techniques include the spacing of studs at 24-inch on center (o.c.); 2-foot modular designs that reduce cutoff waste from standard-sized building materials (Fig. 6.8a); in-line framing that reduces the need for double top plates; building corners with two studs; and insulated headers over exterior building openings (or no headers for non-load-bearing walls). The advantage of spacing studs at 24-inch o.c. rather than 16-inch o.c. is that it reduces the amount of framing lumber required

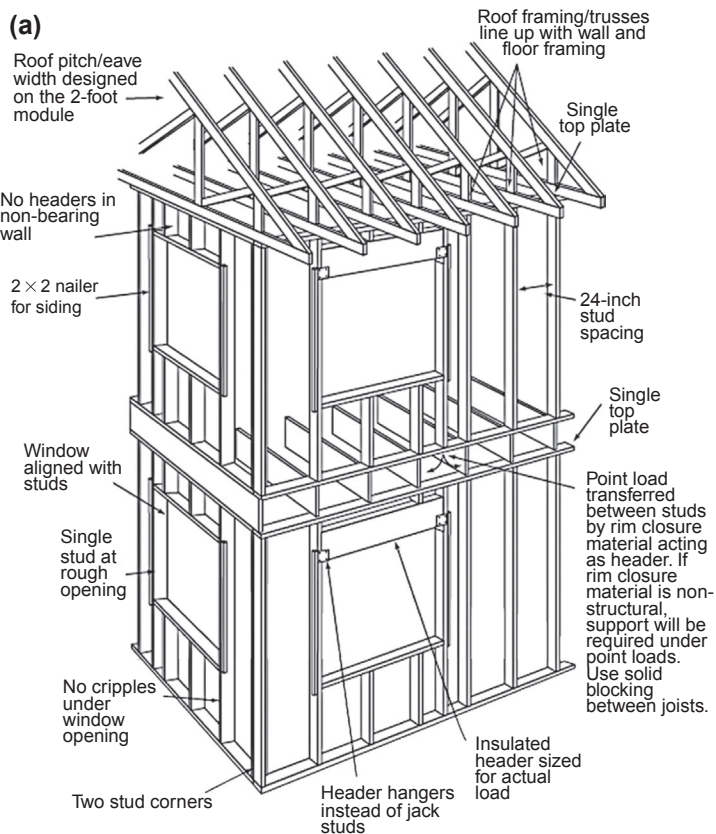

Figure 6.8 (a) Isometric drawing illustrating advanced framing techniques used in residential construction. (b) Isometric drawings illustrating OVE framing details used in residential construction. *Source: Adapted from Building Science Corporation.*

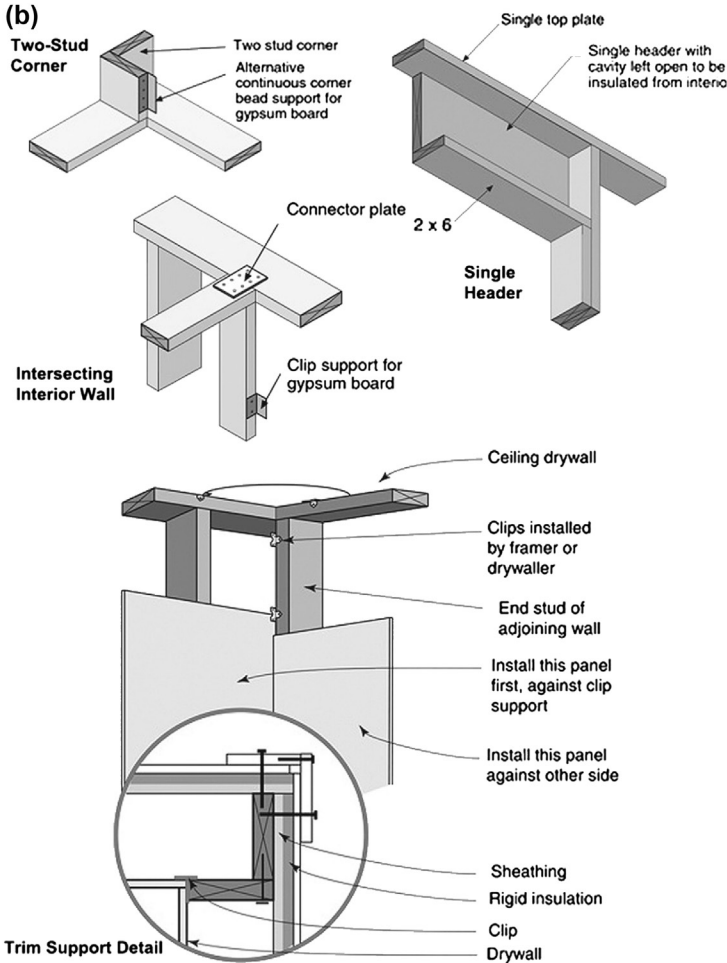

Figure 6.8 Cont'd

to construct a home and replaces framing members with insulation. This allows the wall to achieve a higher overall insulating value and costs less to construct than a conventionally framed wall while still meeting the structural requirements of the home.

Still, to achieve maximum success, advanced framing techniques should be considered at the earliest phases of the design process. For this reason, preliminary building design and planning decisions can significantly impact the ability to effectively implement OVE practices or offset potential benefits that can be achieved by using them. Likewise, including OVE framing details on construction plans can greatly facilitate proper implementation

(Fig. 6.8b). Another key aspect of appropriately selecting OVE framing techniques is the careful consideration of all factors that can impact the final result, including trade-offs that may affect detailing and installation of nonstructural components (such as flooring, trim, and siding) to ensure that the lumber savings are justifiable.

Home owners and builders alike can benefit from advanced framing techniques by providing structurally sound homes that require less material and have lower labor costs than a conventionally framed house. Moreover, additional construction cost savings can be achieved from less construction waste to be disposed of, which also helps the environment. The use of fewer studs in OVE improves energy efficiency and enhances insulation values because fewer studs help maximize the insulated wall area through replacing lumber with increased insulation material and reduction of thermal bridging (conduction of heat through framing).

Conventional framing is often found to be structurally redundant, using wood unnecessarily for convenience. The Department of Energy's Office of Building Technology points out that with advanced framing techniques, savings in material costs of some \$500 per 1200sq. ft. can be achieved in addition to 3–5% of labor costs and a 5% saving in annual heating and cooling costs. While it is true that advanced framing is more wood efficient than conventional framing, it is also true that some alternative structural technologies such as insulated structural systems, straw bale or earthen construction, and high recycled-content steel framing with thermal breaks place fewer demands on our forest resources than OVE framing techniques.

OVE framing techniques have without a doubt been proven to be effective, yet some techniques are, nevertheless, not allowed under certain circumstances (i.e., areas prone to high winds or with seismic potential) or in some jurisdictions. Local building officials should therefore be consulted early in the design phase to verify or obtain acceptance of these techniques. According to the Partnership for Advancing Technology in Housing (PATH), "The OVE techniques that can be practical to implement (if visibly marked on the construction plans) and have noticeable material savings, thermal benefits, and contribute to the quality of the framing job include:

- Right sizing headers according to the IRC 2006
- Three-stud insulated corners
- Ladder-blocking for intersecting walls
- 24" o.c. floor joist framing (using L/480 deflection limits). The use of 2-foot modules helps to make the best use of common sheet-goods' sizes and reduce waste and labor."

PATH goes on to say that, “Future design and construction guidelines for OVE framing must address OVE decision-making factors and potential trade-offs with respect to serviceability considerations, energy-efficiency impacts, installation practices, and manufacturer requirements for various assemblies, components, and finishes. In addition, OVE guidance in the area of wall bracing would fill a needed void created by increased complexity of wall bracing provisions in modern building codes. Current guides tend to stress material savings without in-depth consideration of some of the cost and performance trade-offs involved. The goal should be to optimize, not maximize, the use of OVE framing in the context of all costs and objectives associated with a building project.

Additional OVE framing practices, such as the use of single headers or band-joint headers, should be incorporated into prescriptive building codes to facilitate their use without incurring the added cost of professional engineering for each application.”

Structural insulated panels (SIPs) are high-performance building panels used in floors, walls, and roofs mainly for residential and light commercial buildings. The panels usually consist of two sheets of rigid structural facing board, such as OSB or plywood, which is applied to both sides of a core of rigid foam plastic such as expanded PS (EPS) that is 4 or more inches thick. Alternative skin material can be used for specific purposes. The result of this simple sandwich is a strong structural building system for building walls, roofs, and floors that are significantly more energy-efficient, cost-effective, and yield-improved R-values compared to traditional framing. SIPs are manufactured under factory controlled conditions and can be custom designed for each project. In addition to SIP's excellent insulation properties, it offers airtight assembly, noise attenuation, and superior structural strength. Though SIP panels may initially cost more per square foot than conventional construction, total construction costs are often minimized due to reduced labor and faster completion.

The superior insulation afforded by utilizing the SIP system as well as cost savings due to the reduction in construction waste is especially significant when compared to conventional stick or steel stud systems. SIP panels can be delivered pre-cut to the precise dimensions required, and each panel contains the structure, insulation, and moisture barrier of the wall system. OSB is the most common sheathing and facing material in SIP, reducing wood use by as much as 35% and reducing pressure on mature forests by allowing the use of smaller farm-grown trees for structural applications. OSB differs from traditional plywood in that it has no gaps, laps, knots,

or voids. In most applications, OSB sheathing is also dimensionally stronger and stiffer than comparable dimensional plywood boards, and is a low-emitting material. However, one of an SIP panel's adverse characteristics and for which it has been often criticized is its environmental footprint. Usually the resin adhesive that the OSB strands are bonded together with is not ecofriendly and usually contains formaldehyde which can be toxic, allergenic, and carcinogenic. Recent technological developments appear to be addressing this issue and make SIPs more environmentally friendly.

SIPs are generally chosen for their versatility, strength, cost effectiveness, and energy efficiency and are engineered and custom-manufactured to give the designer greater control over the project, which includes materials and costs. Another advantage of insulated structural systems is that they integrate a building's structure and insulation into a single component. These characteristics also make them suitable for a wide range of residential and commercial applications. SIP wall assemblies are custom-made according to specifications and drawings and therefore tend to be well sealed, thus enhancing energy efficiency. As with any tightly sealed structure, moisture control and well-designed ventilation are critical. SIP construction systems can make a significant contribution to good IAQ; the plastic insulating foams used in their manufacture (EPS or PU/polyisocyanurate) are chemically stable.

SIP cores can be made of several materials, of which EPS is the most common. EPS requires less energy to manufacture than some of the other options and is more recyclable than PU or polyisocyanurate. Many products now offer a 1-h fire rating when installed with 5/8-inch or thicker gypsum sheathing. Another advantage of EPS foam is that it is expanded with pentane, which does not contribute to ozone depletion or global warming; additionally, it is often recaptured at the factory for reuse, thus adding to its value.

Although PU and polyisocyanurate have superior insulation properties per inch of foam than EPS and offer greater resistance to thermal breakdown, they are unlikely to be recycled. Moreover, PU and polyisocyanurate use HCFC blowing agents, which contribute to global warming and ozone depletion (although to a lesser degree than CFCs). Research is currently underway to develop more suitable ecofriendly alternatives for use in SIPs—new resins derived from soy.

The beauty of using straw-core SIPs is that they are made from waste agricultural straw, are renewable, and recyclable, and pressed-straw core does not require a binding agent. The drawback of using straw-core SIPs is that

they offer less insulation per inch of thickness and are significantly heavier than other options; energy used in shipping is a significant consideration when using straw-core SIPs. Preplanning is one of the keys to successful SIP construction, and there are a number of factors to consider when building with SIPs, include:

- SIP designs should be to standardized panel dimensions. Also, to minimize waste, SIP panels should be ordered precut to meet project requirements when delivered to the job site, including window and door openings. This will save 20–30% on framing labor and approximately 30% on waste costs.
- Plumbing and electrical runs need to be predetermined so that the manufacturer can accommodate these needs.
- A tighter house means smaller HVAC systems (up to 40% savings), so when sizing the heating system, consider the thermal performance of SIPs to save money up front and energy over time. Oversized heating and cooling systems are inefficient.
- With improved IAQ, smaller or no air purification systems are required in many climates.
- Roofs using SIP systems often do not require ventilation, making them appropriate for low-slope roofs. If local jurisdiction mandates ventilated roofs, consider SIPs with integrated air channels or upgrading from composition roofing.
- Check to see whether the SIP supplier or manufacturer is willing to take back any offcuts for recycling.

Insulated concrete forms (ICFs) are forms or molds that have built-in insulation for accepting reinforced concrete and are rapidly becoming a mainstream preferred building product. The forms consist of large interlocking modular units that are dry-stacked (without mortar) and filled with concrete. The forms lock together somewhat like LEGO bricks and serve to create a form for the structural walls of a building. Concrete is pumped into the cavity every several feet to form the structural element of the walls. ICFs usually employ reinforcing steel (rebar) before concrete placement to give the resulting walls flexural strength, similar to that of bridges and concrete high-rise buildings. ICFs also employ an insulating material as permanent formwork that becomes a part of the finished wall.

After the concrete has cured or firmed up, the ICFs are left in place permanently to increase thermal and acoustic insulation and render greater fire protection. ICFs can also accommodate electrical and plumbing installations (Fig. 6.9). The end result leaves you with a high-performing wall that is structurally sound, insulated, strapped, has a vapor barrier, and is ready to

accept final exterior and interior finishes. ICFs can generally be considered “green” materials because they are durable, produce little or no waste during construction, and significantly improve the thermal performance of concrete walls. Also, there are no CFCs, HCFCs, or formaldehydes, or wood to rot and mold.

There are essentially three main types of ICF systems on the market. Each type addresses significantly different construction issues and different completed results to the owner. The comparisons are typically based on a

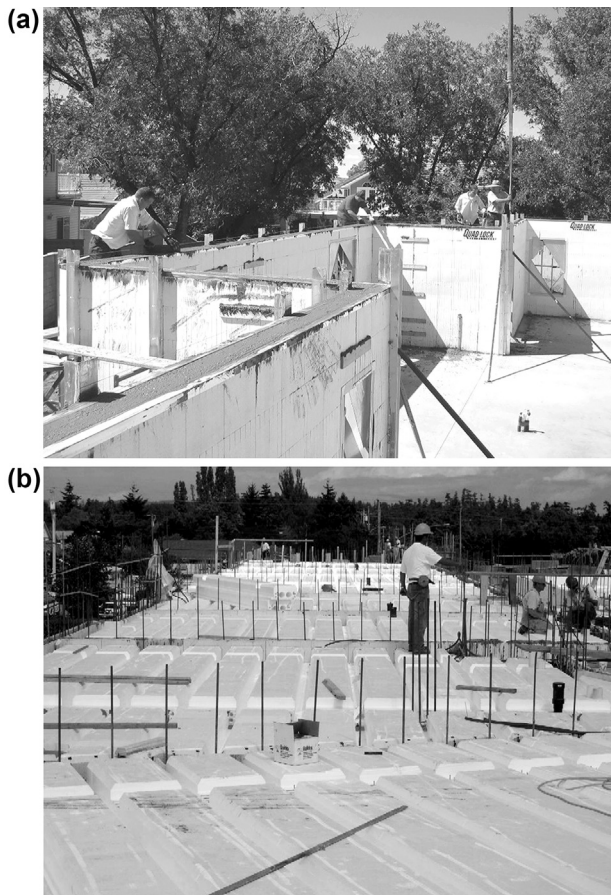

Figure 6.9 (a, b) Two Photos depicting application of insulating concrete formwork Quad-Lock system. This can be considered a “green” material as it is durable, produces little or no waste during construction, and greatly improves the thermal performance of concrete walls and floors. Moreover, Quad-lock panels are molded of fire-retardant Expanded Polystyrene, which is a foamed insulation that has a zero ozone-depletion rating. *Source: Quad-Lock Building Systems.*

variety of different test standards, criteria, and calculations. The different features of the three types are shown below:

- The solid monolithic concrete forms or flat system forms consist of an even thickness of concrete throughout the walls like a conventionally poured wall.
- The waffle-grid system creates a waffle pattern where the concrete is thicker at some points than others.
- The screen grid or post-and-beam system forms consist of detached horizontal and vertical columns of concrete.

An important characteristic of standard concrete is that it is a dense material with a high heat capacity that can be utilized as thermal mass, thereby reducing the energy required to maintain comfortable interior temperatures. One of concrete's negative attributes is that it is not a good insulator, and standard formwork is therefore waste intensive. Additionally, toxic materials are frequently required to separate the formwork from the hardened product. ICF is able to address these weaknesses by reducing solid waste, air and water pollution, and (potentially) construction cost. ICF wall systems have proven to be thermally superior, thus enhancing their usefulness for passive heating and cooling; comfort is also enhanced and energy costs are reduced. Any possible higher initial costs that are incurred can be offset or minimized by the downsizing of the heating/cooling system.

A variety of materials can be employed in the manufacturer of ICF systems including lightweight foamed-concrete panels, rigid foams such as EPS and PU, and composites that combine concrete with mineral wool, wood waste, paper pulp, or EPS beads. Likewise, there are several ICF systems currently on the market that substitute straw bales or fiber cement for PS, such as BaleBlock and Faswall. Rigid foams used in ICFs are generally less green because they do not have significant recycled content and are less likely to be recyclable at the end of their life. However, this does not preclude them from being reused in fill or other composite concrete products to meet market demands.

A distinct attribute of ICFs is that they offer the structural and fire-resistance benefits of reinforced concrete; structural failures due to fire are therefore not common place. By adding flame-retardant additives, PS ICFs tend to melt rather than burn, and interior ICF walls tend to contain fires far better than wood frame walls, improving overall fire safety. As is the case in most heated structures, a key design consideration for ICF walls is moisture control. Solid concrete walls sandwiched in PS blocks tend to be very well sealed to enhance energy efficiency, but they consequently also tend to

seal water vapor within the structure. Potential mold growth and impaired IAQ are serious health concerns that require attention and need addressing. A simple approach to resolving this is by incorporating mechanical ventilation. Certain systems such as straw bale and RASTRA tend to be more vapor permeable, thereby reducing this concern. Several ICF products such as RASTRA are more ecofriendly because they are made from recycled postconsumer PS (foam) waste products.

6.2.9 Concrete

Concrete is a composite building material made up of three basic components: water, aggregate (rock, crushed stone, sand, or gravel), and a binder or paste such as cement. The cement hydrates after mixing and hardens into a stonelike durable material with which we are all familiar. Concrete has a low tensile strength and is generally strengthened by the addition of steel reinforcing bars; this is commonly referred to as reinforced concrete.

Over the centuries, concrete has proven to be a strong, durable, yet inexpensive building material and is widely used as a structural building material in the United States and throughout the world. Due to the increasing scale of concrete demand, the impacts of its manufacture, use, and demolition are widespread. Habitats are disturbed from materials extraction; significant energy is used to extract, produce, and ship cement; and toxic air and water emissions result from cement manufacturing. It is estimated that approximately one ton of carbon dioxide is released for each ton of cement produced, resulting in 7–8% of man-made CO₂ emissions. And although concrete is generally only 9–13% cement, it, nevertheless, accounts for 92% of concrete's embodied energy. Cement dust contains free silicon dioxide crystals, the trace element chromium, and lime, all of which can have negative impacts on worker health and the environment. Mixing concrete requires large amounts of water and generates alkaline waste water and runoff that can contaminate vegetation and waterways.

Admixtures are often added to a concrete mix so as to achieve certain specific goals. Below are some of the main admixtures that are used and what they are designed to achieve:

- *Accelerating admixture* is added to concrete to reduce the concrete's setting time and to accelerate achieving early strength. The amount of reduction in setting time will vary according to the amount of accelerator used. Although calcium chloride is a low-cost accelerator, specifications will often specify a nonchloride accelerator to prevent the corrosion of reinforcing steel.

- *Retarding admixtures* are frequently required in hot weather conditions to facilitate delaying the setting time. They are also used to delay set in more difficult jobs or for special finishing operations such as exposing aggregate. Retarders also often act as a water reducer.
- *Fly Ash* is a residue from coal combustion. Fly ash can replace 15–30% of the cement in the concrete mix. Its use is quite popular as a cement substitute, and its use improves concrete performance, giving greater compressive strength, decreased porosity, greater durability, improved workability, and more resistance to chemical attack, although the curing time is increased. Using fly ash also creates significant benefits for the environment.
- *Water reducing admixtures* will reduce the amount of water needed in the concrete mix. The water–cement ratio will be lower while the concrete’s strength will be greater. Most low-range water reducers reduce the water needed in the mix by 5–10%.
- *Air Entraining Admixtures* should be used whenever concrete is exposed to freezing, thawing, and deicing salts. Air entraining agents entrain microscopic air bubbles in the concrete, so that when the hardened concrete freezes, the frozen water inside the concrete expands into these air bubbles instead of damaging the concrete.

The incorporation of local and/or recycled aggregate (such as ground concrete from demolition) is an excellent way to reduce the impacts of solid waste, transit emissions, and habitat disturbance.

In nonstructural applications, concrete use may be reduced by trapping air in the finished product or through the use of low-density aggregates. Trapped air displaces concrete while enhancing insulation value and reduces weight and material costs without compromising its durability and fire resistance. Similar insulation and weight–reduction benefits are provided by other low-density aggregates such as vermiculite, perlite, pumice, shale, PS beads, and mineral fiber. Cast-in-place or precast concrete and concrete-masonry unit (CMU) considerations include the following:

- Recycling of demolished concrete on site for use as aggregate or fill material for new projects or recycle at local landfills.
- Whenever possible, redeploy portions of existing structures, such as slabs or walls that are in satisfactory condition.
- Employing precast systems to minimize waste of forming material and to reduce the impact of wash water on soils.
- Incorporating the maximum amount of fly ash, blast-furnace slag, silica fume, and/or rice-husk slag appropriate to the project can reduce cement use by 15–100%.

- The employment of alternative material substitutes for concrete should be considered such as ICFs to reduce waste, enhance thermal performance, and reduce construction schedules. Likewise, cellular, foamed, autoclaved-aerated, and other lightweight concretes add insulation value while reducing weight and concrete required. The use of earthen and rapidly renewable materials, such as rammed earth, cob, or straw bale, also help reduce the need for insulation and finish materials in both residential and commercial projects.
- Nontoxic form-release agents to be used when possible.
- Waste can be minimized by carefully planning concrete material quantities.
- Fabric-based form systems should be considered for footings to achieve faster installation and greater wood savings.
- Wood waste and material costs can be reduced by employing steel or aluminum concrete forms, which unlike many wood forms can be reused many times over.
- Permeable or porous/pervious surfaces allow water to percolate into the soil to filter out pollutants and recharge the water table.

Urban and suburban sites typically contain large areas of impermeable surfaces which are causing a number of problems. It is estimated that up to 75% of urban surface area is covered by impermeable/impervious pavement, which are solid surfaces that do not allow water to penetrate, which forces it to run off, and inhibits groundwater recharge, contributing to erosion and flooding, conveying pollution to local waters, and increasing the complexity and expense of storm-water treatment. Also due to the heat-absorbing quality of asphalt and other paving materials, sites with high ratios of impermeable surfaces increase ambient air temperatures and require more energy for cooling, thereby creating a heat island effect.

One of the main characteristics of permeable surfaces/paving (also known as porous or pervious surfaces), on the other hand, is that it contains voids that allow water to percolate into the soil to filter out pollutants and recharge the water table. Pervious paving may incorporate recycled aggregate and fly ash, which help reduce waste and embodied energy. Pervious paving is suitable for use in parking and access areas, as it has a compressive strength of up to 4000 psi. It also mitigates problems with tree roots; percolation areas encourage roots to grow deeper. Enhanced heat exchange with the underlying soil can decrease summer ambient-air temperature by 2–4°F.

Concrete poured-in-place applications require on-site formwork which acts as a mold to give shape to walls, slabs, and other project elements as they cure to a satisfactory strength and after which it is removed (Fig. 6.10).



Figure 6.10 Photo of carpenters setting concrete formwork for high-level waste facility pit walls. *Source: Bechtel Corporation.*

Plywood and milled lumber are the most common form materials, contributing to construction waste and the impacts of timber harvesting and processing. Wooden formwork can be made from salvaged wood and typically be disassembled and reused several times.

Form release agents are materials that prevent the adhesion of freshly placed concrete to the forming surface (which is usually plywood, overlaid plywood, steel, or aluminum). Such materials prevent concrete from bonding to the form, which can mar the surface when forms are dismantled. There are two principal categories of release agents available; these are barrier (nonreactive or passive) and reactive (or chemically active). Barrier release agents prevent adhesion by creating a physical film or barrier between the forming surface and the fresh concrete. Reactive or Chemically active release agents on the other hand work by the process of a chemical reaction between the release agent and the calcium (lime) that is available in fresh concrete. A soapy film is created which prevents adhesion. Also, as it is a chemically reactive process, there is generally little to no residue on the forming surface or concrete thus providing for a cleaner process.

Traditional form releasers such as diesel fuel, motor oil, and home heating oil are carcinogenic and are now prohibited by a variety of state and federal regulations, including the Clean Air Act, because it exposes construction personnel (and potentially occupants as well) to VOCs. Low- and zero-VOC water-based form-release compounds that incorporate soy or other biologically derived oils dramatically reduce health risks to construction staff and occupants and often make it easier to apply finishes or sealants when necessary. Many soy-based options are generally less expensive than their petroleum-based counterparts.

The designing of concrete formwork necessitates that all factors that will adversely affect concrete-formwork pressure be taken into consideration. These factors include the rate of placement, concrete mix, and temperature. The rate of placement should generally be lower in the winter than in the summer. It does not matter how many cubic yards are actually placed per hour or how large the project is. What does matter is the rate of placement per height and time (height of wall poured per hour). Moreover, the forms should also be of sufficient strength and stability to enable it to carry all live and dead loads that may be encountered before, during, and after placing of the concrete. Most exterior type APA panels can be used for concrete formwork because these panels are manufactured with waterproof glue.



6.3 BUILDING AND MATERIAL REUSE

The term *building reuse* generally means leaving the main portion of the building structure and shell in place while performing a “gut rehab,” as it is known in the trade.

6.3.1 Building Reuse

The intent of this LEED Credit is to extend the life cycle of existing building stock, reusing building materials and products, retain cultural resources, reduce waste, protect virgin resources, and reduce environmental impacts of new buildings as they relate to materials manufacturing and transport. This is particularly important for green building because repairing a building rather than tearing it down saves natural resources as well as a significant reduction of materials ending up in the landfill. The reuse of materials is also important because of the embodied energy that is within the production, manufacture, transportation, and construction of the new material. Reuse discourages the production of new products and minimizes the negative impact of embodied energy through reduction in raw material extraction. A key factor in building reuse is the durability of the original structure.

In some states, including North Carolina, grants are provided to renovate vacant buildings in rural counties or in economically distressed urban areas. Note that disaster-recovered materials such as trees uprooted by tornadoes or hurricanes are not eligible for LEED credit.

Maintaining Structural Elements: Existing Walls, Floors, and Roof

LEED requirements for New Construction are to maintain a minimum of 50, 75, or 95% (for up to three points) of the existing building structure (based on surface area), including structural floor and roof decking as well as the envelope (exterior skin and framing but excluding window assemblies and non-structural roofing material). It is possible to achieve a credit by maintaining a minimum of 50% (by area) of interior nonstructural elements of an existing building, such as interior walls, doors, refurbished wood floors, and ceiling systems, of the new building. Hazardous materials that are remediated as a part of the project scope are to be excluded from the calculation of the percentage maintained. The credit will not apply if the project includes an addition to an existing building where the square footage of the addition is more than twice the square footage of the existing building.

Table 6.3 below shows the minimum percent of building-structure reuse required for achieving LEED credits for New Construction (always check USGBC website for latest update). However, for Core and Shell, you are required to maintain a minimum of 25, 33, 42, 50, or 75% of existing walls, floors, and roof for up to five credits. Schools must maintain 55 or 75% of existing walls, floors, and roof for up to two credits. It is strongly advised to check with LEED for the updated requirements of a particular category.

Potential Technologies and Strategies

Potential technologies and strategies: Consider the use of salvaged, refurbished, or reused materials from previously occupied buildings, including structure, envelope, and elements. Hazardous materials that pose contamination risk to building occupants and that are remediated as a part of the project scope shall be excluded from the calculation of the percentage maintained. Upgrade components that would improve energy and water

Table 6.3 Minimum building structure reuse

Building reuse (%)	Points
55	1
75	2
95	3

efficiency, such as windows, mechanical systems, and plumbing fixtures. However, mechanical, electrical, plumbing, or specialty items and components should be excluded for this credit. Furniture may be included only if it is included in the other MR Credits.

Interior Nonstructural Elements

Retain 50% of interior nonstructural elements for New Construction and Schools and 40 and 60% for Commercial Interiors. The intent here according to LEED is to extend the life cycle of existing building stock, conserve resources, retain cultural resources, reduce waste, and reduce environmental impacts of new buildings as they relate to materials' manufacturing and transport.

LEED Requirements

Maintain at least 50% (by area) of existing interior nonshell and nonstructural elements (interior walls, doors, floor coverings, and ceiling systems) of the completed building (including additions). If the project includes an addition to an existing building, this credit is not applicable if the square footage of the addition is more than two times the square footage of the existing building.

In terms of potential technologies and strategies, LEED requires that consideration be given to the reuse of existing buildings, including structure, envelope, and interior nonstructural elements. Hazardous elements that pose contamination risk to building occupants are to be removed, and components that would improve energy and water efficiency, such as mechanical systems and plumbing fixtures, should be upgraded. For the LEED credit the extent of building reuse needs to be quantified, and the owner/developer must provide a report prepared by a qualified person outlining the extent to which major building elements from a previous building were incorporated into the existing building. The report should include preconstruction and postconstruction details highlighting and quantifying the reused elements such as foundations, structural elements, and facades. Windows, doors, and similar assemblies may be excluded.

6.3.2 Materials Reuse

Materials reuse should be 5 and 10% for New Construction, Schools, and Commercial Interiors (30% for furniture and furnishing), and 5% for Core and Shell. The intent is to reuse building materials and products to protect and reduce demand for virgin resources and to reduce waste, thereby reducing impacts associated with the extraction and processing of virgin resources.

LEED Requirements

Use salvaged, refurbished, or reused materials such that the sum of these materials constitutes at least 5, 10, or 30% (for Commercial Interiors, Furniture, and Furnishings), based on cost of the total value of materials on the project. Mechanical, electrical, and plumbing components and specialty items such as elevators and equipment are not to be included in this calculation. Include only materials permanently installed in the project. Furniture may be included, providing it is included consistently in MR Credits 3–7. Most credits in the Material and Resource category are calculated using a percentage of total building materials.

LEED Potential Technologies and Strategies

Include the identification of opportunities to incorporate salvaged materials into the building design and research potential material suppliers. Salvaged materials such as beams and posts, flooring, paneling, doors and frames, cabinetry and furniture, brick, and decorative items should be considered. The difference between Reuse and Recycling is that Reuse is essentially the salvage and reinstallation of materials in their original form, whereas Recycling is the collection and remanufacture of materials into a new material or product, typically different from the original. Biodegradable material breaks down organically and may be returned to the earth with none of the damage associated with the generation of typical waste materials.

C & D are estimated to be responsible for about 30% of the U.S. solid-waste stream. Real-world case studies by the Alameda County Waste Management Authority, for example, have concluded that more than 85% of that material, from flooring to roofing to packaging, is reusable or recyclable. For this reason, reusing materials slated for the landfill has become an extremely eco-friendly way to build, so as to avoid negative elements such as the extraction, manufacture, transport, and disposal of virgin building materials which pollute air and water, deplete resources, and damage natural habitats.

The salvaging of materials from renovation projects and specifying salvaged materials can reduce the costs of material while adding character to projects and maximizing environmental benefits, such as reduced landfill waste, reduced embodied energy, and reduced impacts from harvesting/mining of virgin materials (e.g., logging old-growth or tropical hardwood trees, mining metals, etc.). On the other hand, some materials require remediation or should not be reused at all. For example, materials contaminated by hazardous substances such as asbestos, arsenic, and lead paint must be treated and/or disposed of properly. Avoiding materials that will cause

future problems is critical to long-term waste reduction as well as the health of communities and the environment.

Factors that impact the selection of reusable building materials include:

- Reusing existing building shells, when appropriate, can yield the greatest overall reduction in project impacts.
- Materials from remodeling or renovations should be reused on site.
- Products containing hazardous materials such as asbestos, lead, or arsenic should be disposed of properly or remediated prior to reuse.
- Building materials composed of one substance (e.g., steel, concrete, wood, etc.) or that are readily disassembled are generally easiest to reuse or recycle.
- For remodels and redevelopment, adequate time should be allowed in the construction schedule for deconstruction and recycling.
- Replace inefficient fixtures, components, and appliances (e.g., toilets using more than 1.6 gallons per flush, single-pane windows, and refrigerators or other appliances over 5 years old).
- Note that salvaged materials can vary in availability, quality, and uniformity. Ensure that materials are readily available to meet project needs before specifying them.
- Materials should be carefully evaluated to ensure that they offer the best choice for the application. They need to be durable and can preferably be readily disassembled for reuse, recycling, or biodegrading at the end of the useful life of the building.
- Materials composed of many ingredients, such as vinyl siding, OSB, or particleboard are generally not recyclable or biodegradable.



6.4 CONSTRUCTION WASTE MANAGEMENT

The overall intent of the Construction Waste Management credit is to avoid materials going to landfills during construction by diverting the construction waste, demolition debris, and land-clearing debris from landfill disposal and incinerators; redirecting recyclable recovered resources back to the manufacturing process; and redirecting reusable materials to appropriate sites.

6.4.1 LEED Requirements

Recycle and/or salvage at least 50 or 75% of nonhazardous construction, demolition, and packaging debris (95% for extra credit). Develop and implement a construction waste-management plan that at a minimum identifies and quantifies the materials generated during construction that is to be

salvaged, recycled, refurbished, or diverted from disposal and notes whether such materials will be sorted on-site or comingled. Typical items would include recycled cardboard, metal, brick, acoustical tile, concrete, plastics, clean wood, glass, gypsum board, carpet and insulation, as well as doors and windows, ductwork, clean dimensional wood, paperboard, paneling, cabinetry and plastic used in packing, etc. MEP (mechanical, electrical, plumbing) may now be included although this is not clear from the LEED reference books (Fig. 6.11). Excavated soil, rocks, vegetation, hazardous materials, and land-clearing debris do not contribute to this credit. Calculations can be done by weight or by volume but must be consistent throughout.

Documentation is required for each credit a project attempts to achieve using the LEED system to prove the activity was completed. LEED letter templates are to be used to certify that requirements are met for each prerequisite and credit. Additional documentation may also be required. The contractor will generally be responsible for completing the required LEED documentation for these two credits since the responsibility for construction waste management lies with the contractor.

The LEED Letter Template has to be signed by the architect, owner, or other responsible party, tabulating the total waste material, quantities diverted and the means by which they were diverted, and declaring that the credit requirements have been met. As a portion of the credits in each application may be audited, the contractor should be prepared with backup documentation. Most LEED projects will require a waste-management



Figure 6.11 Truck from DRC Emergency Services unloading construction and demolition debris at Birmingham's New Georgia Landfill, which is being used for brush, tree, construction, and demolition debris from the April 27, 2011, tornadoes. *Source: Birmingham News/Joe Songer.*

plan with regular submittals tracking progress. The plan should indicate how the required recycling rate is to be achieved, including materials to be recycled or salvaged, cost estimates comparing recycling to disposal fees, materials-handling requirements, and how the plan will be communicated to the crew and subcontractors. All subcontractors are required to adhere to the plan in their contracts. Considerations relating to construction waste reduction include:

- The smaller the project, the less material used, reducing both solid waste and operating costs.
- Design of assemblies to match the standard dimensions of the materials to be used.
- Disassembly design should be considered so that materials can be readily reused or recycled.
- Track recycling through construction process (general contractor to keep records, i.e., receipts of recyclable and waste diversion pickups).
- Designate site in construction area for separation process.
- Employ clips and stops to support drywall or wood paneling at top plates, end walls, and corners. Clips can provide the potential for two-stud corners, reducing wood use, easing electrical and plumbing rough-in, and improving thermal performance.
- Materials attached with removable fasteners are generally quicker, cheaper, and more feasible to deconstruct than materials installed with adhesives, although adhesives distribute loads over larger areas than fasteners used alone.
- When possible, make use of existing foundations and structures in good condition, reducing waste, material requirements, and possibly labor costs.
- Design for flexibility and changing use of spaces.
- Specify materials such as SIPs, panelized wood framing, and precast concrete that can be delivered precut for rapid, almost waste-free installation.
- For wood construction, consider 24-inch on center framing with insulated headers, trusses for roofs and floors, finger-jointed studs, and engineered-wood framing and sheathing materials.
- Whenever practical, specify materials with high recycled content.

According to the United States Environmental Protection Agency (U.S. EPA), “Commercial construction typically generates between 2 and 2.5 pounds of solid waste per square foot, the majority of which can be recycled. Salvaging and recycling C&D waste reduces demand for virgin resources and the associated environmental impacts. Effective construction

waste management, including appropriate handling of non-recyclables, can reduce contamination from and extend the life of existing landfills. Whenever feasible, reducing initial waste generation is environmentally preferable to reuse or recycling.”

The EPA goes on to say that, “The Construction Waste Management Plan should ideally recognize project waste as an integral part of overall materials management. The premise that waste management is a part of materials management, and the recognition that one project’s wastes are materials available for another project, facilitates efficient and effective waste management.”

It is also important for waste-management requirements be taken into account early in the design process and be a topic of discussion at both preconstruction and ongoing regular job meetings to ensure that contractors and appropriate subcontractors are fully informed of the implications of these requirements on their work prior to and throughout construction. Furthermore, the EPA states that “Plan Implementation of the waste management should be coordinated with or part of the standard quality assurance program and waste management requirements should be addressed regularly throughout the project. If possible, adherence to the plan would be facilitated by tying completion of recycling documentation to one of the payments for each trade contractor.”



6.5 RECYCLED MATERIALS

Material Recycling can be defined in several ways depending largely on the different processes that recycling is involved in. It can be as simple as reusing a given product beyond its intended use such as passing old clothes on to charities, the poor, or relatives, to avoid throwing them out so that someone else can make good use of them. However, Recycling is more commonly associated with the practice of recovering old goods from the waste stream and reincorporating them into the manufacturing process, thus allowing them to be turned into new products. The Recycling process of waste materials into new products therefore helps prevent the waste of potentially useful materials and reduces the potential consumption of fresh virgin materials. Additionally, it lessens energy usage, reduces air pollution (by incineration), and reduces the need for “conventional” waste disposal. Recyclable materials is a key component of modern waste reduction and can take many forms including different kinds of plastic, paper, glass, metal, textiles, and electronics.

According to the Environmental Building News (BuildingGreen.com), “*Recycled content* refers to the portion of materials used in a product that have been diverted from the solid waste stream. If those materials are diverted during the manufacturing process, they are referred to as *preconsumer* recycled content (sometimes referred to as postindustrial). If they are diverted after consumer use, they are *postconsumer*.”

Postconsumer content is generally viewed as offering greater environmental benefit than preconsumer content. Although preconsumer waste is much more vast, it is also more likely to be diverted from the waste stream. Postconsumer waste is more likely to fill limited space in municipal landfills and is typically mixed, making recovery more difficult.

To claim that it is using preconsumer recycled content, a company must be able to substantiate that the material it is using would have become garbage, had it not purchased it from another company’s waste stream, for example. If a manufacturer routinely collects scraps and feeds them back into its own process, that material does not qualify as recycled.”

Recycled content is the most widely cited attribute of green building products. The LEED intent for MR Credit 4.1 is to protect virgin resources by increasing demand for building products with recycled content.

The LEED requirements are: “Use materials with recycled content such that the sum of postconsumer recycled content plus one-half of the preconsumer content constitutes at least 10% (based on cost) of the total value of the materials in the project. The recycled content value of a material assembly shall be determined by weight. The recycled fraction of the assembly is then multiplied by the cost of assembly to determine the recycled content value.

Mechanical, electrical and plumbing components and specialty items such as elevators shall not be included in this calculation. Only include materials permanently installed in the project. Furniture may be included, providing it is included consistently in MR Credits 3–7.”

Recycled content is to be defined in accordance with the International Organization of Standards (ISO) document, *ISO 14021—Environmental Labels and Declarations—Self-declared Environmental Claims (Type II Environmental Labeling)*. Companies claiming to use preconsumer recycled content must be able to substantiate that the material it is using would have been discarded, had it not been purchased from another company’s waste stream. However, if the manufacturer routinely collects scraps and feeds them back into its own process, that material according to LEED does not qualify as recycled.

Many federal, state, and local government agencies around the nation have established “buy recycled” programs aimed at increasing markets for recycled materials. Among these include, The California Department of Resources Recycling and Recovery (CalRecycle), San Mateo County, Iowa Program, Montgomery County, and others. These programs support the Department of General Services (DGS), other State agencies, as well as local governments in establishing policies and practices for purchasing recycled-content products (RCPs), in addition to supporting activities that promote waste reduction and management. Likewise, a principal goal of these programs is supporting all recycling activities to reduce solid-waste disposal, and many communities in the United States now offer regular curbside collection or drop-off sites for certain recyclable materials. Materials collection in itself, however, is insufficient toward making the recycling process work. Successful recycling also requires that manufacturers produce viable products from the recovered materials and, in turn, there is a market ready to purchase products made of recycled materials.

Recyclability is a characteristic of materials that maintain useful physical or chemical properties after serving their original purpose and which therefore allows them to be reused or remanufactured into additional products through a recognized process. In fact, many national and international companies constantly seek an environmental marketing edge by advertising the recycled content of their products, which is often undocumented or certified and often misleading. Such claims come under the jurisdiction of the Federal Trade Commission (FTC), which first published definitions for common environmental terms in its Green Guides in 1992. The LEED Rating System offers credit for recycled-content materials, referencing definitions from ISO 14021. However, these definitions leave a lot of gray areas, which many manufacturers often interpret in their own favor. Third-party certification of recycled content is useful in maintaining a high standard and offering the ability to verify any claims that are made regarding sustainability.

Waste is not a luxury we can afford, although we have to bear it. Yet, the extraction, manufacture/transport, and disposal of building materials continue to clog our landfills, pollutes our air and water, deplete our resources, and damage our natural habitats. The CIWMB notes that C & D waste comprised 22% of California’s solid-waste stream in 2004. Probably, more than 85% of that material, from flooring to roofing, and much of that material can be salvaged for reuse or recycled. In addition to C & D waste,

we must also consider the material in our recycling bins, our used bottles, paper, cans, and cardboard, which can provide suitable raw materials for RCPs. But keeping a material out of the landfill is only the first step to putting “waste” back into productive use. The “waste” has to be reprocessed into a new, quality product, and that product must be cable of being sold to an entity that recognizes its benefits. The reprocessing of our “waste” as the raw material for new products, increases demand for recycling, and encourages manufacturers to employ more recycled material, continuously strengthening this cycle.

The benefits of using recycled-content materials are many and include reduced pollution, reduced solid waste, reduced energy and water use, reduced greenhouse gas emissions, and a healthier IAQ. Below is a partial list of materials that are readily recyclable and which generally may cost less to recycle than to dispose of as garbage:

- Acoustical ceiling tiles
- Asphalt
- Asphalt shingles
- Cardboard
- Carpet and carpet pad made of plastic bottles (or sometimes from used carpet); up to half of all polyester carpet made in the United States contains recycled plastic
- Concrete containing ground-up concrete as aggregate, fly ash—a cementitious waste product from coal-burning power plants—asphalt, brick, and other cementitious materials
- Countertops made with everything from recycled glass to sunflower-seed shells
- Drywall made with recycled gypsum and Homasote wall board made from recycled paper
- Fluorescent lights and ballasts
- Insulation, such as cotton made from denim, newspaper processed into cellulose, or fiberglass with some recycled-glass content
- Land-clearing debris (vegetation, stumpage, dirt)
- Metals (pipes, rebar flashing, steel, aluminum, copper, brass, and stainless steel)
- Paint (use a hazardous waste outlet)
- Plastic film (sheeting, shrink wrap, packaging)
- Plastic and wood-plastic composite lumber from plastic and wood chips, ideal for outdoor decking and railings
- Tile containing recycled glass

- Window glass
- Wood (Includes engineered products; nails are acceptable)
To achieve maximum benefit when selecting a recycled-content building material, the following points should be taken into consideration:
 - Choose materials that contain the highest recycled content possible. For example, a recycled product that is 70% recycled is preferable to one that is only 10% recycled and 90% virgin material.
 - Choose materials with high postconsumer recycled content. Some “recycled” content is waste from manufacturing processes. Reducing manufacturing waste is important, but recycling postconsumer material is necessary to close the loop.
 - Choose materials that are appropriate for the application in hand.
 - Salvaging (reusing) whole materials is preferable to recycling, and all but eliminates waste, energy, water use, and pollution.
 - When possible, choose materials that are both recycled and also recyclable or biodegradable at the end of their useful life. Ideally, a material may be continuously recycled back into the same product.

Reclaimed wood has many applications, including, but not limited to, flooring, siding, furniture, and in some cases as structural members. Reusing wood from an existing building on site should be carefully considered, or where appropriate, look to salvage yards and on-site deconstruction sales for a portion of a project’s material needs. It is important to note that salvaging or reusing wood can reduce solid waste, save forest resources, and save money. Moreover, reclaimed wood is often available in dimensions, species, and old-growth quality that is no longer available today. [Table 6.4](#) lists examples of Reusable (RU), recyclable (RC) and biodegradable (B) building materials.

Deconstruction consists of the systematic disassembly of a building, with the purpose of recovering valuable materials for reuse in construction, renovation, or manufacturing into new wood products, thereby preserving the useful value of its component materials. Deconstruction is preferable to demolishing; the combination of various tax breaks, new tools, and increasing local expertise are making it easier to keep materials out of the landfill. Deconstruction has grown by leaps and bounds in recent years, due mainly to new for-profit and nonprofit entities throughout the United States. Although deconstruction takes longer and may initially cost more than demolition, it is, nevertheless, likely to reduce the overall project cost. Waste reduction has the benefits of minimizing energy use, conserving resources, and easing pressure on landfill capacity.

Table 6.4 RU, RC, and B building materials

Reusable	Recyclable	Biodegradable
Bricks	Asphalt	Earthen materials
Doors and windows	Bricks	Gypsum wall board
Earthen materials	Concrete, ground and used as aggregate	Linoleum flooring
Gypsum wall board	Metal: Steel, aluminum, iron, copper	Straw bales
Lighting fixtures	Wood and dimensional lumber, such as beams, trusses, studs, and plywood	Wood and dimensional lumber, such as beams, trusses, studs, and plywood
Metal: Steel, aluminum, iron, copper		Wool carpet
Plumbing		
Unique and antique products that may no longer be available		
Wood and dimensional lumber, such as beams, trusses, studs, and plywood		



6.6 REGIONAL MATERIALS

Regional materials are those that are extracted, harvested, and manufactured within a 500 miles radius of the project site. The main LEED intent here is to reduce material transport by increasing demand for building materials and products that are extracted and manufactured within the region where the project is located, thereby supporting both use of indigenous resources and the regional economy as well as reducing the negative environmental impacts associated with transportation.

6.6.1 LEED Requirement

Use a minimum of 10 or 20% (based on cost) of total building materials and products that are extracted, harvested, recovered, or manufactured regionally within a radius of 500 miles of the site (Fig. 6.12). To calculate, either the default 45-percent rule or actual materials cost may be used. All mechanical, electrical, plumbing and specialty items such as elevator equipment need to be excluded. If only a fraction of the product/material is extracted, harvested, recovered, or manufactured within 500 miles of the site, then only



Figure 6.12 Diagram of a map program that is capable of drawing any required radius for any chosen location. *Source: Free Map Tools, www.freemaptools.com.*

that percentage (based on weight) may contribute to the regional value. Furniture may be included only if it is included throughout MR Credits 3 to 7. Of note, “manufacturing” alludes to the final assembly of components into the building product that is furnished and installed by the contractor. Thus, if the hardware comes from Los Angeles, California, the lumber from Vancouver, British Columbia, and the joist assembled in Fairfax, Virginia, then the location of the final assembly destination is considered to be Fairfax, Virginia. One or two points can be earned for using materials that are both harvested and manufactured within a 500-mile radius of the site. In LEED for Commercial Interiors (and in older versions of LEED for New Construction and LEED for Core & Shell), one point is given for merely manufacturing within that radius, and a second point for harvesting as well.

By simply tracking the materials that are typically produced and supplied within 500 miles of the project site, it is possible to achieve the 20-percent-credit threshold without impacting the cost. In some cases, however, the 20-percent threshold can only be achieved by targeting certain materials (e.g., specific types of stone or brick) or limiting the number of manufacturers whose products are to be considered in the project bids. In such instances, there is a possibility of incurring additional costs.

To verify that the extraction/harvest/recovery site is located within a 500-mile radius of the project site, project teams are required to attest to the actual mileage between the project site and the manufacturer and, likewise, attest to the distance

between the project site and the extraction site for each indigenous material in the submittal template. Alternatively, a statement on the manufacturer's letterhead indicating that the point of manufacture is within 500 miles of the LEED project site will also be accepted as part of the documentation and credit submittals. The benefit of using indigenous materials is that it reduces transportation distances and the associated environmental impacts.



6.7 RAPIDLY RENEWABLE MATERIALS

Rapidly renewable materials are those that grow back very quickly. These can be sustainably harvested at a fairly high rate, so the burden of proof is less for certification as it is for wood products. Rapidly renewable materials are numerous and include bamboo, cork, insulation, linoleum, straw-bale, wheat board, wool, etc. These are considered sustainable because they are natural, nonpetroleum-based building materials (petroleum-based materials are nonrenewable) that can be grown and harvested within 10 years. LEED states that the intent of using rapidly renewable materials is to “reduce the use and depletion of finite raw materials and long-cycle renewable materials by replacing them with rapidly renewable materials.” LEED MR Credit 6.0 states that to be eligible for credits, rapidly renewable materials must be equal to no less than 2.5% of the cost of a building project in terms of value. It has been found that the use of rapidly renewable resources can often save land as well as other resources that usually go into conventional materials. Moreover, because of their shorter harvesting cycles, rapidly renewable materials provide environmental benefits and are able to sustain a community for a longer period than more finite sources can.

6.7.1 Bamboo

Bamboo is considered to be one of many rapidly renewable resources for LEED certification under MR Credit 6. Furthermore, some bamboo lines are also made with no formaldehyde, thereby contributing to EQ 4.4—Low-Emitting Materials. Partly because of its rapid regeneration, Bamboo has emerged as an alternative resource to other types of wood commonly used in the United States and abroad. In the past, it was used as a basic material for making household objects and small structures, but continuous research and engineering efforts have enabled bamboo's true value to be realized. That the bamboo plant meets all the criteria of being rapidly renewable is because when harvested sustainably, it will regrow from the same root stalk, maturing in just a few years, whereas trees such as oak and maple take far longer to grow

and are incapable of regrowing from the same plant, in addition to the fact that they can be harvested only once.

Technically, Bamboo is not a wood; it's a giant grass that comes in 1500 varieties that produces hard, strong, dimensionally stable wood. It can be found in many tropical regions of Asia, Africa, and South America. It has been used as both a building material and for furniture construction for thousands of years (Fig. 6.13a). In addition to being considered to be a fast-growing woody plant, it is also one of the most versatile and sustainable building materials available. Bamboo can reach maturity in months in a wide range of climates—and is exceedingly strong for its weight and can be used both structurally and as a finish material. Likewise, it can be clear-cut and will grow right back.

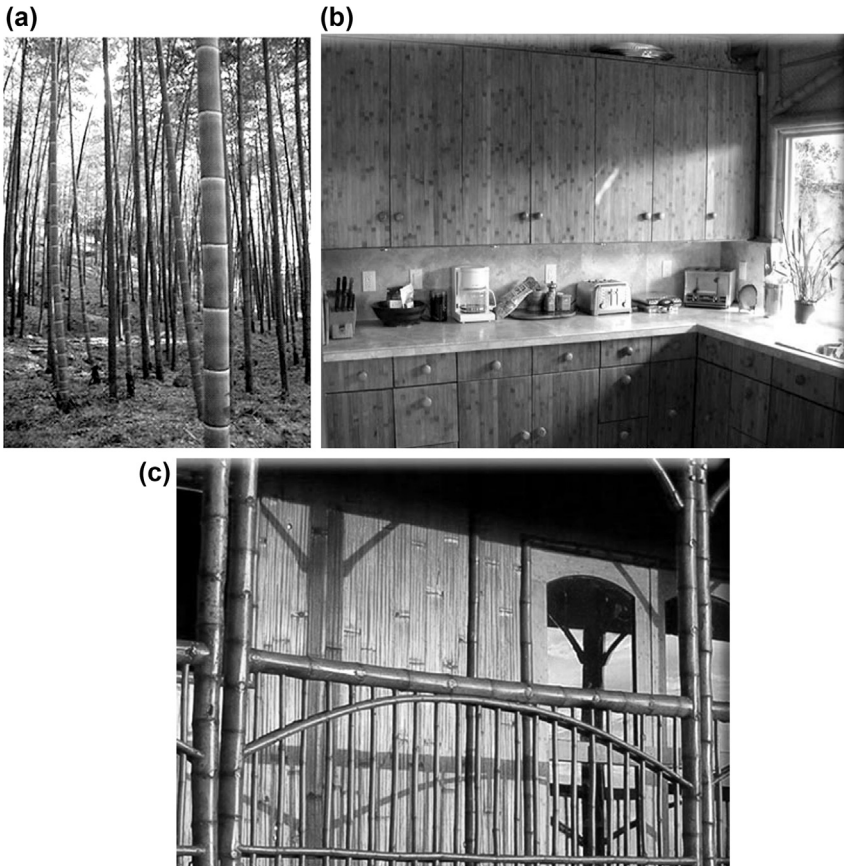

Figure 6.13 (a) Bamboo plants in Kyoto, Japan. (b) Kitchen cabinets made of bamboo. (c) Photo showing use of bamboo as exterior siding. Sources: (a) Wikipedia, photo by Paul Vjaar, 2004; (b and c) Bamboo Technologies.

Bamboo's rapid regeneration, strength, and durability make it an environmentally superior alternative to conventional hardwood flooring. While some hardwood trees may require decades to reach maturity, bamboo can usually be harvested on a 4- or 5-year cycle, and the mature forest will continue to send up new shoots for decades. Pine forests are known to have the most rapid growth among tree species, but bamboo grass species used in flooring can grow much faster—more than 3 ft. per day and produce nearly twice as much harvestable fiber per year. At the same time, Bamboo can yield a product that is 13% harder than rock maple and durability comparable to red oak. Nevertheless, one has to be careful with bamboo as an inferior manufacturing process can sometimes neutralize the hardness benefits of the material itself. Indeed, a poor-quality topcoat will scratch no matter how durable the flooring. Bamboo canes have a natural beauty when exposed which is why it is often used for paneling, furnishings, and cabinetry (Fig. 6.13b and c).

Many developing countries around the world, especially those with more tropical climates, and where Bamboo often grows into larger diameter canes, have a long vernacular tradition for its use in structures. However, the general use of bamboo today in the United States is limited by a lack of architects and/or engineers trained in bamboo design, joining systems, harvesting, treatment and strength of relevant species, as well as a lack of capable carpenters with the skills to economically and efficiently build bamboo structures. One of the issues to confront the sustainability of bamboo is the amount of transportation it requires to get it to North America. The majority of bamboo currently used in hardwood flooring comes from Hunan Province in China which means it has to be shipped across the ocean to get to North America and then put on trucks or trains to get to its final destination.

When using bamboo, particular care should be given to joinery details, since its strength comes from its integral structure, and it cannot be joined with many of the traditional methods used with wood. In this respect, the ancient ways of building with bamboo can be especially informative. Also, exposing bamboo to heavy moisture can eventually destroy it by fungus, which is what happens when it is exposed to adverse weather. Even with direct exposure, it is possible to prevent this by injecting it with chemical formulae of varying levels of environmental acceptability.

Tests have shown Bamboo to be an extremely strong fiber having twice the compressive strength of concrete and roughly the same strength-to-weight ratio of steel in tension. Some bamboo fibers also have greater shear

strength than structural woods and take much longer to come to ultimate failure. However, Bamboo has the ability to bend without breaking which makes it unsuitable for building floor structures due to our low tolerance for deflection and lacking a willingness to accept a floor that has a “bouncy” feel. An appropriate substitute for the standard oak is a ¾-inch-thick bamboo finished floor because it installs the same way, is harder, and expands less. Likewise, vertically laminated flooring and plywood products that consist of layers of bamboo compressed with a binder can create a durable, resilient finish material. And when well maintained, bamboo floors can last for decades. Like most interior-grade hardwood plywood, bamboo flooring is typically made with a urea-formaldehyde binder, which can emit tiny amounts of formaldehyde. To counter this and minimize indoor-air pollution caused by the use of urea-formaldehyde, it is important to choose high-quality products, particularly from manufacturers that provide independent air quality testing data.

6.7.2 Cork

Ninety nine percent of the world’s cork grows in the sunny Mediterranean. Cork is a natural, sustainable product harvested from the bark of the cork oak, *Quercus suber*. It can be first harvested when it is 25 years old, when the virgin bark is carefully cut from the tree. It should be noted that from the three layers of the cork bark that is harvested, only the middle layer is used to make cork products. And the harvesting of cork does not require a single tree to be cut down, and only a percentage of the bark is removed from each tree, thus allowing it to maintain its protection while regenerating. Following this, the tree can be regularly “stripped” of its cork every 9 years for roughly 200 years without any harm coming to the tree. This helps to encourage long-term management of this renewable resource. It is estimated that an 80-year-old cork tree can produce nearly 500 pounds of cork. And unlike synthetic vinyl flooring, cork provides a resilient building alternative with a 50+ year lifespan compared to the 10- to 20-year lifespan of synthetic flooring. It also has a negligible impact on energy performance at its point of use.

Cork applications are becoming increasingly popular due to its unusual characteristics—a combination of beauty, durability (can last for decades), insulation, and renewability (see Fig. 6.14). Likewise, modern cork floors are very durable, fire resistant, and provide thermal and acoustic insulation. In addition to being soft on the feet, Cork is also antimicrobial and inherently resistant to mold and mildew, has low off-gassing from natural oils, does not produce chemicals during the manufacturing process (dioxin specifically), and

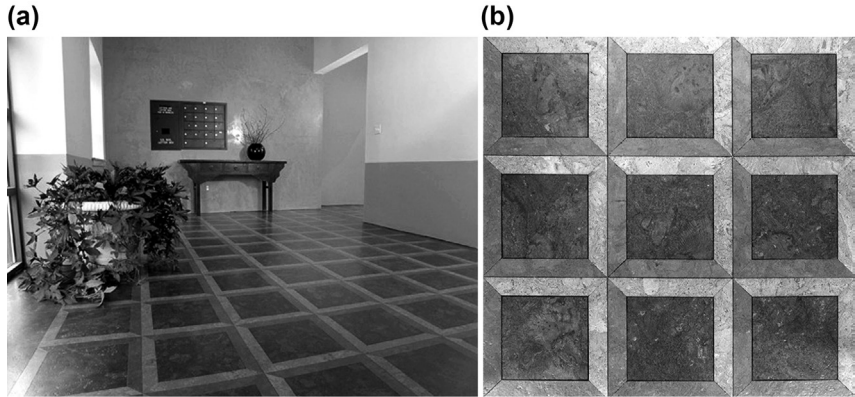

Figure 6.14 (a) Residential interior using cork flooring. (b) Cork pattern detail. *Source: Globus Cork.*

the material is completely biodegradable. Cork adapts well to weight and will recover from large amounts of pressure which makes it appropriate for use in kitchens and laundry rooms. They are usually covered with an acrylic finish but may alternatively be covered with PU for bathroom or kitchen applications. The extraction, manufacture, transport, and disposal of synthetic flooring materials on the other hand, pollutes air and water, depletes resources, damages natural habitats, and can have negative health impacts.

Cork floors are sometimes considered as a natural alternative to carpet because it provides the majority of the benefits of carpet without its liabilities. Carpet can attract and hold indoor pollutants in its fibers, whereas cork is easier to thoroughly clean, sheds no dust or fibers, and is naturally antistatic. In addition to its hypoallergenic properties, it offers thermal and acoustic insulation. But the benefits of using cork go beyond human health; they include less landfill waste (it can be recycled back into the manufacturing process to minimize further waste), many products locally obtainable, exemplary aesthetics, and reduced ecological impacts of harvesting/mining the raw materials. However, there is significant regulation for cork harvesting (unlike bamboo), and to minimize potential damage to the trees and ecosystems, countries that harvest cork monitor the frequency at which the resource can be harvested.

6.7.3 Insulation

The majority of insulation employed in buildings is for thermal purposes, but the term also applies to acoustic insulation, fire insulation, and impact insulation (e.g., for vibrations caused by industrial applications). Insulation will therefore help to protect a building's occupants from heat, cold, and noise, in addition

to reducing pollution while conserving the energy needed to heat and cool a building. Insulation materials will often be chosen for their ability to perform several of these functions at once, and well-insulated building envelopes are primary considerations in comfort and sustainability. Environmentally preferable insulation options can offer additional benefits, such as reduced waste and pollution in manufacture and installation, as well as a more efficient resource use, better recyclability, improved R-value, and reduced or eliminated health risks for installers and occupants. The comfort and energy efficiency of a home or office depend on the R-value of the entire wall, roof, or floor (i.e., whole-wall R-value) and not just the R-value of the insulation.

Fiberglass which is usually the material of choice for insulating ceilings and walls consists of extremely fine glass fibers. Its popularity is often based on economic grounds even though its use may present potential health risks. It is advisable that all fiberglass insulation used be formaldehyde free with a minimum 50% total recycled content (minimum 25% postconsumer). Some products are manufactured with heavier, intertwined glass fibers to reduce the amount of fibers becoming airborne and also to mitigate the fraction of fibers that can enter the lungs. One of the issues with using Fiberglass fibers is that they are friable and can easily become airborne, particularly during installation. These fibers can be inhaled, and some health experts claim that this particulate matter is carcinogenic.

Fiberglass insulation is similar to other glass products in that it is made primarily from silica heated to high temperatures, requiring significant energy and releasing formaldehyde. Short-term effects that may be experienced during installation or other contact include irritation to eyes, nose, throat, lungs, and skin. Longer-term effects are controversial, but OSHA now requires fiberglass insulation to carry a cancer warning label. Binders in most fiberglass batts contain toxic formaldehyde that continues to slowly emit for months or years after installation, potentially contaminating indoor air.

There are also various environmentally preferable insulation options including the use of recycled cotton, which insulates as well as fiberglass and offers superior noise reduction. Cotton insulation typically comes in batt form and is easy to work with. It is also soft, not irritating during installation and poses no health risk to the installer (unlike fiberglass) or occupants, nor does it use a formaldehyde-based binder. To maximize its energy performance, the insulation should be fitted to completely fill the wall and ceiling cavities without being compressed by pipes or wires. Cotton insulation can retain up to 15% moisture, which may not create problems in walls assemblies that are dry or are able dry out between cycles of water loading. However,

care should be taken to avoid repeated wetting and drying which could cause the borate treatment to seep out and encourage the growth of mold. Also, cotton insulation costs roughly twice as much as fiberglass batts, bearing in mind that insulation material costs are generally a very small percentage of the total cost of construction. In addition, the excellent sound and safety qualities of cotton insulation give it an edge over fiberglass.

BioBased Insulation is essentially PU spray-in-place foam that is manufactured with annually renewable soybean oil, which allows it to be classified as a rapidly renewable product. Such innovative products have excellent thermal and sound insulating properties that can help to provide a healthy, comfortable, energy-efficient, and durable residential or commercial building. Depending on the size, cost, and amount of the project insulated, BioBased Insulation can contribute a significant portion of LEED's required 2.5% of rapidly renewable products and materials used in the project.

Likewise, cellulose (recycled newspaper) insulation can be an acceptable alternative because it generates a nontoxic, fire-retardant insulation product. It also acts as an effective protective shield to reduce the transmission of heat or sound and is suitable for insulation of Timber Frame Walls, Attics, and Lofts. It poses no health risk and offers superior R-value per inch. Both cellulose and cotton are treated with borate, which is not toxic to humans and makes both materials more resistant to fire and insects than fiberglass. Some cellulose insulation products are manufactured entirely from recycled newspaper which might otherwise end up in a landfill.

Sprayed PU foam is sometimes used in large to midscale applications and is sprayed onto concrete slabs, into wall cavities of an unfinished wall, or through holes drilled in sheathing or drywall into the wall cavity of a finished wall to provide insulation, vapor barrier, and additional shear strength. Although the cost of Sprayed PU foam can be high compared to traditional insulation, it is offset by many advantages, including increased structural stability (unlike loose-fill), and blocking airflow through expansion and sealing off leaks, gaps, and penetrations. Sprayed cementitious foams such as Air-Krete have similar properties. Air-Krete is environmentally friendly, nontoxic, nonhazardous, fireproof, nonexpansive, insect resistant, mold proof, zero VOC emission, and Insoluble in water.

6.7.4 Linoleum

Linoleum is a highly durable, environment friendly, resilient material that is used mainly for flooring. It is made from a mixture of natural materials such as solidified linseed oil (linoxyn), recycled wood flour, ground cork

dust, pine rosin, and mineral pigments which are mounted onto a jute-fiber backing. Linoleum is also naturally antibacterial and biodegradable. The manufacture of Linoleum requires mixing oxidized linseed oil (or a combination of oxidized linseed oil and tall oil) and rosin with the other raw materials to form linoleum granules. The granules are then pressed onto a jute backing, creating Linoleum sheets. These sheets are then hung and allowed to cure in special drying rooms to achieve the required flexibility and resilience. Maximum waste reduction is achieved by recycling back any linoleum remnants into the production process. Linoleum manufacturing should be conducted in accordance with ISO 14001 standards. LEED credits may be given for purchasing local materials.

Although Flexible vinyl flooring (often incorrectly referred to as linoleum), largely displaced linoleum from the marketplace in the 1960s, Linoleum has made a dramatic reappearance in the marketplace as a flooring choice for those who are environmentally conscientious. In addition, being made of organic materials and purportedly nonallergenic in nature, high-quality linoleum continues to be in use in many places (especially in nonallergenic homes, hospitals, and health care facilities). The two materials are quite different. First costs of linoleum are higher, but linoleum offers certain performance advantages that are superior to vinyl, such as lasting longer, being inherently antistatic, as well as antibacterial. Moreover, all-natural, linoleum requires less energy and creates less waste in its manufacture, and it can be chipped and composted at the end of its useful life. Maintenance of linoleum is likewise less labor intensive and less expensive as it does not require sealing, waxing, or polishing as frequently as vinyl. On the other hand, flexible vinyl flooring remains a more prolific generator of solid waste because it is manufactured from toxic materials and will typically last about 10 years; it is neither biodegradable nor generally recyclable. Linoleum also emits far fewer VOCs when installed with a low-VOC adhesive than flexible vinyl and does not exude the phthalate plasticizers that are an increasing concern for human health.

Vinyl tile is still favored over many other kinds of flooring materials in various commercial and institutional applications where high traffic is anticipated because of its characteristically low cost, durability, and ease of maintenance. The durability of hard VCT may be comparable to linoleum, but recycling has until recently been impractical, which is why VCT tile usually ends up in a landfill. However, new technology has allowed VCT to contain increasingly high percentages of recycled content, reduced energy consumption, and waste generation. But vinyl products can, nevertheless,

be harmful because their manufacture consumes petroleum and involves the generation of hazardous wastes and air pollution. Important Linoleum attributes include:

- It is made from all natural nontoxic materials, and these natural raw materials are available in abundance.
- It does not contain formaldehyde, asbestos, or plasticizers.
- Very durable, often lasting for 25–40 years; this helps reduce waste associated with the frequent replacement of flexible vinyl flooring.
- It is 100% biodegradable at the end of its useful life.
- It is resilient, quiet, and comfortable.
- Linoleum can be 100% recycled. As a common alternative to incineration, linoleum can be safely added to landfill refuse sites, where natural decomposition takes place.
- It is easy to clean and maintain, using gentle detergent with a minimal amounts of water. However, Linoleum floors can be kept in satisfactory condition for long periods without the need for major maintenance.
- While its resistance to temporary water exposure makes it suitable for use in kitchens, its sensitivity to standing water is a concern for use in bathrooms.
- Its natural bactericidal and antistatic properties help control the presence of dust and dirt and the subsequent growth of household mites and/or bacteria.
- It contains virtually no trace of toxic material and therefore very low VOC emissions (no off gassing) when installed with appropriate adhesives, and is thus naturally beneficial to air quality.
- Square-foot cost may be comparable to high-quality flexible vinyl flooring, although flexible vinyl is commonly replaced within 10 years (as opposed to 25–40 years for linoleum) and is toxic to manufacture; it is neither biodegradable nor recyclable.
- It is the same color all the way through, which permits gouges and scratches to be buffed out, reducing long-term costs and waste.

Linoleum is also considered to be a rapidly renewable resource, which has environmental advantages over finite raw material and long-cycle renewable resource extraction.

6.7.5 Straw-Bale Construction

Straw and reeds have been used as building materials in the Middle East for thousands of years (Fig. 6.15). Today, Straw-bale building consists of stacking a series of rows of compressed blocks (bales) of straw (often in running bond),

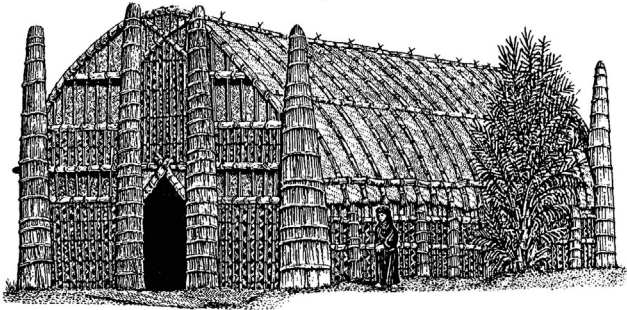

REED DWELLING (MUDHIF)



Figure 6.15 Illustration of a typical Marsh Arab Mudhif (Guest House) made of reed which is similar to that built in Mesopotamia (ancient Iraq) thousands of years ago by the Sumerians.

on a raised footing or foundation, with a moisture barrier between. This can be implemented as fill for a wall cavity (nonload-bearing) or as a structural component of a wall in which the bales may actually provide the support for openings and roof (load bearing). The most common nonload-bearing approach is using a post-and-beam framework that supports the basic structure of the building, with the bales of straw being employed as infill (serving mainly as insulation and plaster substrate). This method is also the main one that is permitted in many jurisdictions, although many localities now have specific codes for straw-bale construction. Until recently, “field-bales,” bales that were created on farms with baling machines have been used, but lately higher-density “recompressed” bales have come into use that are increasing the loads that may be supported. Whereas field bales may be capable of

supporting roughly 600 pounds per linear foot of wall, the high-density bales are designed to support up to 4000 pounds per linear foot. This is particularly important in northern regions, where there is a potential for snow-loading that can exceed the strength of the straw-bale walls.

In wet climates, it is necessary to apply a vapor-permeable finish that precludes the use of cement-based stucco commonly used on load-bearing bale walls, since the interior and exterior sides of a bale wall is usually covered by stucco, plaster, clay, or other treatment. This type of construction can offer structural properties superior to the sum of its parts. Both load- and nonload-bearing straw-bale designs divert agricultural waste from the landfill for use as a building material with many ecofriendly qualities.

Straw-bale construction is increasing in popularity in many parts of the country, partly because it lends itself well to an owner builder project, so that today there are thousands of straw-bale homes in the United States. However, in designing load-bearing straw-bale buildings, architects and engineers must take into consideration the possible settling of the straw bales as the weight of the roof and other elements compress them. It is also important to ensure that the straw is kept dry, or it will eventually rot. For this reason, it is generally best to allow a straw-bale wall to remain breathable; any incorrectly applied moisture barrier may invite condensation to collect and potentially undermine the structure. Additionally, the skin on the straw-bale walls should be treated to resist infestation of rodents and insects.

Straw bale houses can typically save about 15% of the wood that would normally be needed in a conventionally framed house. However, it should be noted that Straw-bales do not hold nails as well as wood, and thus nailing surfaces need to be provided. Also, because of the specialized work that goes into plastering both sides of straw-bale walls (to provide thermal mass), and the extra expense needed to protect them from moisture, the cost of finishing a straw-bale house sometimes exceeds that of standard construction. Moreover, because Straw-bale walls are thick, they may constitute a high percentage of the floor area which may be problematic on a small site. Nevertheless, the final product often provides excellent value because of the superior insulation and wall depth that is achieved. Advantages of employing straw-bale construction methods include:

- Provides extemporary thermal insulation, thereby enhancing occupant comfort. It is estimated that a well-built straw bale home can save you nearly 75% on heating and cooling costs. Applying interior plaster to straw-bale houses increases the “thermal mass” of the home, which helps to stabilize interior temperature fluctuations.

- Straw-bale provides superior acoustic insulation which is particularly helpful for home owners seeking to block out exterior noise emanating from traffic or airplanes in urban environments.
- Straw-bale is environmentally friendly and does not require toxic treatment, thereby helping chemically sensitive individuals.
- Straw-bales are inexpensive (or free), and owners, builders, and volunteers are able to contribute significantly to labor.
- Straw-bale construction offers much greater fire resistance (roughly three times that of conventional construction).
- Typically, a traditional “stick frame” home of 2×6 construction will often have an insulating value of R-14, whereas with a properly insulated roof straw-bale can increase this to an R factor of R-35 to R-50.
- It reduces construction waste which has a positive impact on the environment. The main building material is a waste product, and any excess straw can be used on-site in compost or as soil-protecting ground cover.
- Straw-bale is biodegradable or reusable at the end of its useful life.
- Has potential for major reductions in wood and cement use, particularly in load-bearing straw-bale designs. In a load bearing assembly, the wood in the walls can be completely eliminated, except around the windows.
- Conventional foundations and roofs can be employed with straw bale-buildings.
- Highly resistant to vermin (including termites).
- Provides great potential for aesthetic flexibility from conventional linearity to organic undulation.
- Using straw as insulation means that unhealthy insulation materials cease to be required. For example, fiberglass insulation generally has formaldehyde in it, a known carcinogen will no longer be used. Bale walls also eliminate the use of plywood (which often contains unhealthy glues) in the walls.

As can be deduced from the preceding, straw-bale provides a notable alternative building material that helps to reduce or eliminate many of the environmental problems that plague the environment (Fig. 6.16).

6.7.6 Wheat Board

One of the more popular renewable materials is wheat board, which is a fiber-composite by-product of wheat-straw. This material is environmentally friendly, has no formaldehyde, and can be used to create, among other things, quality furniture and cabinets. Wheat board is a durable material that is produced in 4 foot by 8 foot sheets of various thicknesses and posses



Figure 6.16 An interior of a residence built of straw-bale. *Source: StrawBale Innovations, LLC.*

superior panel properties compared to wood-based composite panels. It can be painted or laminated with a wide variety of surface treatments, sealed, stained, or varnished. It can also be shaped in a wide variety of designs, and is used in millwork, cabinetry, and finished product applications for a renewable, nontoxic alternative to commercial MDF. It can also provide a sustainable alternative to traditional wood flooring and gypsum walls.

In the past, wheat board has been burned or added to landfills. Today, there are a number of manufacturers that produce wheat board in the United States, Canada, and Europe. It is a viable substitute for wood and benefits the environment by reducing deforestation and also lessening both air pollution and landfill use. In addition to its versatility, using wheat board can also help a building project earn crucial LEED credits for rapidly renewable materials (Credit 6—Rapidly Renewable Resources), recycled content (Credit 4.1/4.2—Recycled Content), and IAQ (Credit 4.1 Low-emitting adhesives and sealants).



6.8 GREEN OFFICE EQUIPMENT

Today the nation is transitioning to a more service focused economy, a large portion of which are small businesses, in which the amount of energy-consuming office equipment will also increase.

This is why for some time now enlightened designers, building owners, and leading edge organizations have been searching for ways to reduce their environmental footprint by becoming greener, both at home and at

the work place. Likewise, manufacturers of office equipment are responding to consumer desire for more environmentally sound products. One of the main driving forces behind this trend has been the ENERGY STAR program which was begun by the U.S. EPA in 1992.

Modern research shows that office equipment accounts for approximately 16% of an office's energy use, and buildings generally contribute about 40% of U.S. CO₂ emissions, and therefore even minor changes at the office can potentially have a significant impact. And although the energy component generally represents about 30% of operating expenses in a typical office building, thereby making it the single largest and most manageable operating expense in the provision of office space, many facility operators unlike their enlightened counterparts, nevertheless, fail to focus on the energy-consuming office equipment or appliances when they consider energy consumption. Instead they unwittingly focus on building operations such as lighting and air-conditioning and its shell components.

People often do not realize that the cost of energy to operate office equipment or an appliance over time can cost substantially more than the original cost of the equipment itself. Moreover, choosing the most energy-efficient models available can have a positive impact on the environment while at the same time saving money. Nevertheless, more often than not, building owners and tenants decide to choose the cheapest and least expensive equipment or appliance on the market, which means that the owner/tenant ends up spending the minimum amount up front on an appliance or office equipment, only to find that they are paying through the nose for years to come in recurring monthly energy costs. It is also important that all nonessential electrical equipment (TVs, copiers, computers, VCRs, etc.) be switched off at night or when not in use.

It is no secret that much of the energy and water that appliances and office equipment consume promptly translates into additional fuel being burned at power plants, which in turn contributes to air pollution, and the waste of our limited natural resources. The good news is that continuous technological advances have helped create efficient new appliances and office equipment that can use only one-half to one-third as much energy as those purchased only a decade ago. The Lawrence Berkeley Laboratory reports that the replacement of older appliances and equipment such as refrigerators, dishwashers, clothes washers, thermostats, heating equipment, and incandescent lighting with ENERGY STAR equipment, enough energy and water can be saved to provide an average after tax return on investment (ROI) of over 16%. This is a substantially better return than the

stock market. Moreover, in today's era of escalating energy costs and climate change, energy efficiency has become the most important aspect of greening a business.

In the United States, most retailers carry efficient, durable appliances and office equipment. Appliances and equipment with the ENERGY STAR label are typically preferred, although they are not necessarily always the most efficient of all available models. Nevertheless, ENERGY STAR® products do usually perform significantly better than federal minimum efficiency standards. ENERGY STAR is a label from the U.S. EPA that identifies various energy-saving products in over 60 product categories, including appliances, lighting, office equipment, and consumer electronics. According to a 2002 EPA report, ENERGY STAR-labeled office buildings generally generate utility bills that are 40% less than the average office building. In addition, there are often rebates and/or incentives for the purchase of energy- and water-saving appliances. Inefficient office equipment not only draws power but also emits heat that can contribute to higher cooling bills.

Factors that should be considered when selecting office equipment and appliances:

- Always buy appliances and equipment that use the least energy and preferably are ENERGY STAR-qualified products. The ENERGY STAR label indicates the most efficient light bulbs, computers, printers, copiers, refrigerators, televisions, windows, thermostats, ceiling fans, and other appliances and equipment.
- Install appliances and equipment that use the least water, e.g., low-flow showers, faucets, toilets, urinals, hose valves, etc. (Zero-water urinals, 1-gpf toilets, and 0.5-gmp faucets are all readily available.)
- Choose durable appliances and equipment that meet long-term needs.
- For space and water heating, select natural-gas appliances; gas is often more cost effective and can reduce overall energy, but, like other fossil fuels, it is not a renewable resource.
- Incorporate sealed combustion and direct-vent furnaces and water heaters to increase IAQ.
- Consider using occupancy sensors in offices to minimize unnecessary lighting, as well as "smart" energy-efficient power strips that combine an occupancy sensor with a surge protector; smart power strips will shut down devices (such as monitors, task lights, space heaters, and printers) that can be safely turned off when space is unoccupied. The latest versions can be found with remote control shut-offs, main shut-offs that can power down peripheral equipment, and motion-detecting shut-offs.

- Install low-cost energy monitors that can provide an accurate display of the cost and energy use of individual equipment. Research shows that this step alone can lead to energy savings of up to 40%.

By using green office equipment, there is also the potential to achieve LEED credit points. For example, for existing buildings the requirements for electronics can be found in the MR 2.1 section under “Sustainable Purchasing: Durable Goods, Electric,” which states:

One point is awarded to projects that achieve sustainable purchases of at least 40 percent of total purchases of electric-powered equipment (by cost) over the performance period. Examples of electric-powered equipment include, but are not limited to, office equipment (computers, monitors, copiers, printers, scanners, fax machines), appliances (refrigerators, dishwashers, water coolers), external power adapters, and televisions and other audiovisual equipment.

As for residential construction, ENERGY STAR offers homebuyers many of the features they desire in a new home, in addition to the energy-efficient improvements that deliver better performance, greater comfort, and lower utility bills. To earn the ENERGY STAR label, a home is required to meet strict guidelines for energy efficiency as set by the U.S. EPA. Such homes are typically 20 to 30% more efficient than conventional homes.



6.9 FORESTRY CERTIFICATION AND CERTIFIED WOOD

Forest certification was launched more than a decade ago to help protect forests from destructive logging practices. It involves the green labeling of companies and wood products that meet specific standards of “sustainable” or “responsible” forestry, while at the same time providing a means for independent organizations to develop standards of good forest management and independent auditors to issue certificates to forest operations that comply with those standards. The intention is therefore to reflect a seal of approval and a means of notifying consumers that a wood or paper product comes from forests managed in accordance with strict environmental and social standards. For example, a person shopping for wall paneling or furniture would seek a certified forest product to ensure that the wood was harvested in a sustainable manner from a healthy forest and not procured from a tropical rainforest or the ancestral homelands of forest-dependent indigenous people.

The primary purpose of forest certification is that it provides market recognition for forest producers who meet a set of agreed-upon environmental and social standards. The importance, therefore, of this certification is that it

verifies that the forests are well managed, as defined by a particular standard, and ensures that certain wood and paper products come from responsibly managed forests. This is particularly important today since current forestry practices have a multitude of negative effects on the environment such as soil erosion and loss of wildlife habitat.

The Intent of the LEED Certified Wood credit here is to encourage such environmentally responsible forest-management programs. The Green Globes rating system, unlike the LEED rating system, does not have an FSC-only policy. Moreover, there has been much controversy relating to certified in the LEED Rating System and LEED encountered considerable criticism.

In response to the USGBC's recently released new rating system LEED 2012, which took effect in 2012, the American Forest Foundation (AFF) states that while recognizing the significance of the proposed changes, it believes that the story for wood remains unchanged and the increase recognition of American Tree Farm System wood remains unchanged. AFF believes that "While wood is an energy-efficient, renewable, carbon sequestering material, LEED has done very little to promote the environmental benefits of wood or to encourage builders to choose wood products—essentially blocking wood from the growing green building market." LEED has also been at odds with the National Lumber and Building Material Dealers Association (NLBMDA) regarding certifications. Earlier rewrites of the certified wood policy in the LEED rating systems unfortunately failed to get a two-thirds majority votes from USGBC members to become a policy. Without a two-thirds majority, the policy failed to pass under LEED rules, and the certified wood credits will remain unchanged. Melissa Harden, a Public Affairs Manager at AFF, says that, "Builders and architects can collect few credits under LEED for using wood, and the credits that are related to wood products are even more restrictive. For example, under the current LEED system, the forest certification credit does not recognize the two largest forest certification standards in North America, the American Tree Farm System and the Sustainable Forestry Initiative, only wood certified by the FSC is recognized. LEED 2012 is even more restrictive in only recognizing 'FSC Pure' certified wood products. Very few North American wood products are certified as FSC Pure." Harden goes on to say that "While LEED 2012 does offer some new changes with seeming potential for increased recognition of wood products, these new changes come with additional questions. For example, LEED 2012 would allow materials, like wood, to achieve recognition through performance-based Life Cycle

Assessment (LCA) and Environmental Product Declarations (EPDs).” And although the LEED 2012 recognizes products that are “bio-based,” they rely on the U.S. Department of Agriculture’s (USDA) definition and database of BioPreferred products. USDA’s BioPreferred program currently does not include products with a mature market—therefore including the majority of paper and wood products.

The criteria for LEED certified wood credits continue to change, and it is best to be constantly updated by checking with the USGBC website. Previously, LEED awarded credit to projects that used wood certified to the standards of the FSC for at least half of their wood-based materials. The USGBC has now purportedly broadened the credit to recognize any forest-certification program that meets its criteria. The change is partly in response to criticism that LEED favors one forest-certification program, FSC, over others—in particular, the Sustainable Forestry Initiative (SFI), a rival to the FSC that is portrayed by some environmentalists as being less rigorous. Nevertheless, the revision brings the credit into line with a trend in LEED toward using transparent criteria to determine which third-party certification programs to recognize.

At present the FSC, remains the only certification program granted a “certified wood credit” in the LEED system, although LEED claims that it will recognize wood certification programs that are found to be compliant with the benchmark. On the other hand, wood certification programs that are not found to be in alignment with the benchmark would have a clear and transparent understanding of what modifications are needed to receive recognition under LEED. A number of other programs, including SFI and the Canadian Standards Association (CSA), may face some difficulty with parts of the LEED benchmark system to receive certification.

In recent years, many progressive companies have decided whenever possible to preferentially buy wood and paper from FSC-certified suppliers, although they still use products from other sources to meet their needs. According to the USGBC, homebuilders can currently earn up to 6.5 points out of a possible 136 for using FSC-certified wood. Specifically, they can earn a half point each for using FSC-certified wood in:

- Exterior wall framing
- Exterior wall siding
- Flooring
- Floor framing
- Interior wall framing
- Decking
- Cabinets

- Counters
- Doors
- Trim
- Window framing
- Roof framing
- Sheathing

The SCS has emerged as a global leader in certifying forest-management operations and wood-product manufacturers. It first developed its Forest Conservation Program in 1991, and in 1996 the FSC accredited it as a certification body, enabling it to evaluate forests according to the FSC Principles and Criteria for Forest Stewardship. Through a well-developed network of regional representatives and contractors, SCS provides timely and cost-effective certification services globally. Implementation requirements to achieve the LEED credit include:

- A minimum of 50% of wood-based materials and products used which are certified in accordance with an accredited certifier (e.g., FSC) meeting these principles and criteria for wood building components such as framing, flooring and subflooring, wood doors, etc.
- Based on cost of sustainable wood products as determined by the ratio of total cost of wood material purchased for the project, unlike previous credits which are based on total materials purchased.
- MEP and elevator equipment to be excluded.
- Furniture may be included in calculation.
- Contractor does not require the certification number but supplier does.

To receive the new pilot credit, LEED projects must validate that, based on value, at least 10% of nonstructural products meet any of the following requirements:

- Product environmental claims to be verified by a third party
- Products are certified to third-party multiattribute performance standards
- Product manufacturer completed a LCA report or a third-party verified Environmental Product Declaration for the product.

Many thought that the certified wood controversy had ended last December with USGBC's decision to keep the FSC as the only wood that gets a point for being sustainably harvested. However, a new and very confusing controversial credit has recently been introduced that appears to get a foot in the door for other certification systems. It was recently noted in a press release from UL Environment, which does third-party certification. They explain that the credit is designed to promote use of certified products.

The recently released pilot credit will be used as a “testing ground” or “trial run” credit before its formal adoption into the LEED rating system. This new pilot credit is important to the sustainable building community because certified products provide a mechanism for market transformation as it awards points for improving performance, transparency, and evaluation of the environmental impact of products and materials. The President of UL Environment, Steve Wenc, echoes this, “This move toward increased performance, transparency, authenticity and third-party verification of manufacturers’ claims will help transform the market.” We have yet to see if it does.



6.10 LIFE-CYCLE ASSESSMENT AND LIFE-CYCLE COST ANALYSIS OF BUILDING MATERIALS AND PRODUCTS

LCC analysis (LCCA) is discussed in greater detail in [Chapter 10](#).

6.10.1 Life-Cycle Assessment

LCA, also known as life-cycle analysis, is the analysis method most directly related to sustainability. It is a technique for assessing environmental impacts associated with all the stages of a product’s life from cradle-to-grave. “Cradle-to-grave” begins with the extraction of raw materials from the earth to create the product through materials processing, manufacture, distribution, use, repair and maintenance, and disposal or recycling, thus ending at the point when all materials are returned to the earth. LCA, therefore, is a tool that takes into account the entire life cycle of a product. It assesses the many stages of a product’s life from the point of view that they are interdependent, meaning that one operation leads to the next.

An important characteristic of LCA is that it enables the estimation of the cumulative environmental impacts emanating from all stages in the product life cycle, often including impacts not considered in more traditional analyses (e.g., raw material extraction, material transportation, ultimate product disposal, etc.). Inclusion of these impacts throughout the product’s life cycle provides for a more accurate assessment of a materials true environmental impact and allows LCA to offer a more complete view of the environmental features of the product or process and a fundamentally improved picture of the true environmental compromises in product and process selection. It also takes into account any resale or salvage value recovered during or at the end of the time period examined. This type of analysis allows for comprehensive and multidimensional product comparisons.

6.10.2 Life-Cycle Cost Analysis

According to the National Institute of Standards and Technology (NIST) LCC is defined as “the total discounted dollar cost of owning, operating, maintaining, and disposing of a building or a building system” over a period of time. LCC is therefore an economic evaluation methodology for assessing the total cost of acquiring, owning, and operating a facility over a period of time and takes into consideration relevant costs of alternative building designs, systems, components, materials, or practices in addition to the multiple impacts on the environment (both positive and negative) that building materials and certain products have. LCCA can prove especially useful when comparing project alternatives that fulfill similar performance requirements but differ with respect to initial costs and operating costs, so that one can be selected for maximum net savings. One of the advantages of LCCA is that it can be applied to both large and small buildings as well as to isolated building systems. However, LCCA is not helpful for budget allocation.

Whenever possible, anticipate and determine from the outset the potential health and safety issues that may emerge during the construction, occupation, maintenance, alteration, and disposal of the facility. Many astute building owners apply the principles of LCCA in decisions they make regarding construction or improvements to a facility. While initial cost has always been an important factor in the decision-making process, it is only one factor of several that impact the final decision.

Related to LCA, LCC measures the opportunity cost of one investment versus another alternative and provides data as to which might provide a better ROI. LCC provides a systematic evaluation of financial ramifications of a material, a design decision, or a whole building, and unlike a simple payback analysis, the LCC examines both the initial cost of a project, as well as the expected operations, maintenance, financing, useful life, and any salvage value that the project may have at the end of its life. LCC’s tools can also help calculate future factors such as payback period, cash flow, present value, internal rate of return, and other financial criteria. It can then calculate a present value of the future investment using a discount rate percentage that is specific to the investor’s requirements. This can go a long way toward comprehending how a modest up-front cost for environmentally preferable materials or design features can provide a very sound investment over the life of a building.

Lowest life-cycle cost is considered the most straightforward and easy-to-interpret system of economic evaluation. There are other commonly used measures available, such as internal rate of return, savings-to-investment ratio, net savings (or net benefits), and payback period.

If the same criterion and length of study period are used, then these systems are all compatible with the lowest LCC measure of evaluation. Quantity surveyors, architects, cost engineers, and others might choose any or several of these techniques to evaluate a project. The approach to making cost-effective choices for building-related projects can be quite similar whether it is called cost estimating, value engineering, or economic analysis. Open-book accounting, when shared across the whole project team, helps everyone to see and appreciate the project's actual costs. The LCCA should typically be performed early in the design process while there remains an opportunity to refine or modify the design in a way that would reduce LCCs.

Sieglinde Fuller of the NIST says that "The first and most challenging task of an LCCA, or any economic evaluation method for that matter, is to determine the economic effects of alternative designs of buildings and building systems and to quantify these effects and express them in dollar amounts." Fuller also believes that when viewed over a 30-year period, initial building costs have been shown to generally account for approximately just 2% of the total, while operations and maintenance costs equal 6% and personnel costs reflect the lion's share of 92% (Source: Sustainable Building Technical Manual/Joseph J. Romm, *Lean and Clean Management*, 1994).

A variety of building-related costs are associated with acquiring, operating, maintaining, and disposing of a building or building system. These costs typically fall into one of several categories (see [Chapter 10](#)) including:

- First costs: purchase, acquisition, construction costs
- Operation, maintenance, and repair costs
- Fuel costs
- Replacement costs
- Residual values: resale or salvage values or disposal costs
- Finance charges: loan interest payments
- Nonmonetary benefits or costs

It is not necessary to include costs that are minor and insignificant in amount or costs within each category that are irrelevant to making a valid investment decision. For relevancy, costs should vary from one alternative to another. Significance is achieved when the costs are large enough to make an appreciable difference in the LCC of a project alternative. For calculation purposes, costs are entered as base-year amounts in today's dollars. The LCCA method is then applied which accelerates these amounts to their future year of occurrence and then discounts them back to the base date to convert them to current dollar values.

Of note, detailed construction cost estimates are not required for preliminary economic analyses of alternative building designs or systems. Detailed estimates are usually unavailable until the design is fairly advanced and the possible contingency for cost-reducing modifications has been missed. LCCA can be repeated throughout the different stages of the design process whenever more detailed cost information becomes available. To start with, construction costs may be estimated by referencing historical data from similar facilities, or they can be estimated using government or private-sector cost-estimating guides and databases.

Detailed cost estimates rely mainly on cost databases such as the *R. S. Means Building Construction Cost Database*. They are usually prepared at the submittal stages of design and are based on quantity takeoff calculations. There are also several well-known testing organizations such as ASTM International and the NIST as well as various trade organizations that have reference data available for materials and products they represent or have tested. To avoid or minimize cost overruns, the discerning owner/developer needs to have:

- A complete sustainable design that meets planning and statutory requirements and one that will not later necessitate modification
- A project brief that is comprehensive, unambiguous, and consistent
- Green goals that are appropriate and unlikely to be subject to modification during the course of the project
- A coordinated sustainable design that from the beginning takes into account factors such as maintenance, health and safety, IAQ, etc.
- An uncomplicated payment mechanism that incentivizes the parties to achieve common and agreed objectives
- Clear leadership with a qualified project team and appropriate management controls in place
- Project estimates using BIM technology or similar to provide realistic and comprehensive cost estimates
- An appropriate risk allocation and contingency that is clear and unambiguous



6.11 THIRD-PARTY CERTIFICATION

The LEED third-party certification program is an internationally recognized green building certification system and benchmark for the design, construction, and operation of high-performance green buildings, and that a building or community was designed and built employing strategies

and methods intended to improve performance in metrics such as energy savings, water efficiency, and improved indoor environmental quality, etc. According to Alice Soulek, Vice President of LEED development, “Third-party certification is the hallmark of the LEED program,” and “Moving the administration of LEED certification under GBCI will continue to support market transformation by delivering auditable third-party certification. Importantly, it also allows USGBC to stick to the knitting of advancing the technical and scientific basis of LEED.”

Moving the administration of the LEED certification process to the Green Building Certification Institute (GBCI), a nonprofit organization established in 2007 with the support of USGBC, was a wise decision and is having far-reaching positive ramifications for the USGBC and its influential LEED rating systems. Working together with the selected certification bodies, GBCI is now in a better position to deliver a substantially improved, ISO-compliant certification process that will continue to grow with the green building movement.

USGBC has decided to outsource LEED certification to independent, accredited certifiers overseen by GBCI. In that respect, the USGBC’s Leadership in Energy and Environmental Design (LEED) v3 has announced the names of the certification bodies for the updated LEED Green Building Rating System. The companies are well known and respected for their role in certifying organizations, processes, and products to ISO and other standards. A list of the members can be found in [Chapter 2](#), Section 2.3.5. This development in the certification process has been undertaken as an integrated part of a major update to the technical rating system that was put in place as LEED 2009. The update will also include a comprehensive technology upgrade to LEED Online aimed at improving the user experience and expanding its portfolio-management capabilities.

To acquire LEED credits, third-party testing and certification are required, so as to provide an independent analysis of manufacturers’ environmental performance claims, based upon established standards. This provides building owners and operators with the tools required to have an immediate and measurable impact on their buildings’ performance. Sustainable building strategies should be considered early in the development cycle. An integrated project team will include the major stakeholders of the project, such as the developer/owner, asset and property-management staff, BIM manager, architect, engineer, contractor, and landscape architect.

Making choices based on third-party analysis is often easier than LCA, but it is vitally important to determine the independence, credibility, and

testing protocols of the third-party certifiers. Michelle Moore, senior vice president of policy and public affairs at USGBC, says, “We believe in third-party certification,” and “the USGBC provides independent third-party verification to ensure that a building meets these high performance standards. As part of this process, USGBC requires technically rigorous documentation that includes information such as project drawings and renderings, product manufacturer specifications, energy calculations, and actual utility bills. This process is facilitated through a comprehensive online system that guides project teams through the certification process. All certification submittals are audited by third-party reviewers.” Moore also believes that the separation of LEED from the certification process will bring LEED into alignment with norms established by the ISO for certification programs.

For healthy IAQ, green-building materials and methods should typically have zero or low emissions of toxic or irritating chemicals and be moisture, and should also be mold resistant. Green materials and products are typically manufactured with a low-pollution process from nontoxic components, have low maintenance requirements, and do not require the use of toxic cleansers. This may explain why most green materials do not emit VOCs, particularly indoors, and are free of toxic materials such as chlorine, lead, mercury, and arsenic. While individual products do not carry LEED points, they can, nevertheless, contribute to LEED points. Green-building strategies include the monitoring of indoor pollutants and poor ventilation through the use of radon and carbon monoxide detectors. The use of ozone-depleting gases such as halons and HCFCs are to be avoided.

Indoor Environmental Quality

7.1 GENERAL OVERVIEW

Indoor Environmental Quality (IEQ) is essentially described as the conditions inside the building, which typically includes air quality, and access to daylight, views, pleasant acoustic conditions, and occupant control over lighting and thermal comfort. And it is not surprising to learn that poor IEQ has become one of the major concerns we face today not only in the home, but also in education facilities and the workplace. IEQ can lead to poor health, learning difficulties, and productivity problems. This is particularly worrying since the majority of us spend most of our time indoors (especially in the United States); it is not surprising therefore that we should expect our indoor environment to be healthy and free from the plethora of hazardous pollutants. Indoor pollution is found to exist under many diverse conditions from dust and bacterial buildup in ductwork to second-hand smoke and the off-gassing of paint solvents, all of which are potential health hazards.

Studies by the *American College of Allergies* show that roughly 50% of all illness is aggravated or caused by polluted indoor air (Fig. 7.1). Moreover, cases of building-related illness (BRI) and sick building syndrome (SBS) continue to rise. In fact, recent studies point to the presence of more than 900 possible contaminants, from thousands of different sources, in a given indoor environment. It is not surprising therefore that indoor air pollution is now generally recognized as having a greater potential impact on public health than most types of outdoor air pollution, causing numerous health problems from respiratory distress to cancer.

Furthermore, a building interior's air quality is one of the most pivotal factors in maintaining building occupants' safety, productivity, and well-being. This heightened public awareness has led to a sudden surge of building occupants demanding compensation for their illnesses. Especially in today's increasingly litigious society, they add another factor to be addressed—protecting their investment from liability due to air-quality issues. Moreover, tenants are not only suing building owners, but some are also architects, engineers, and others involved in the building's construction.

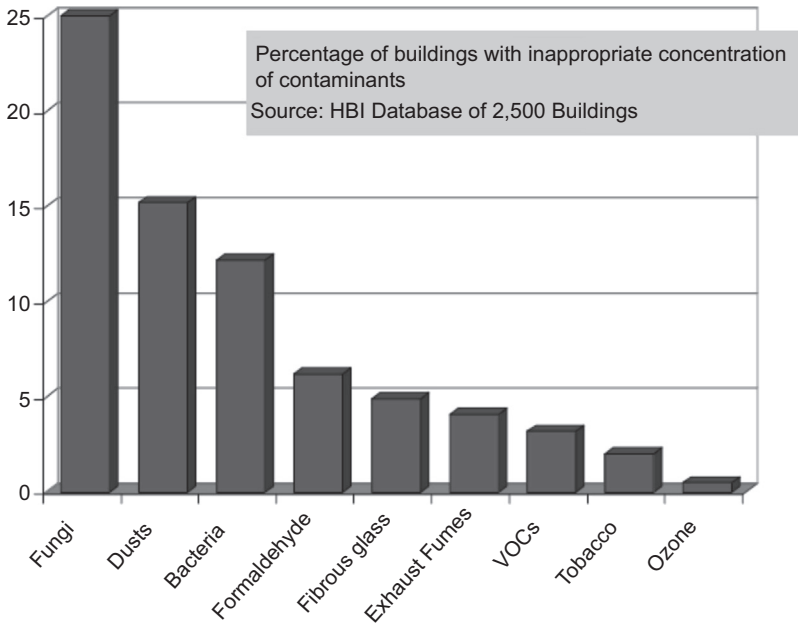

Figure 7.1 Percentage of buildings with inappropriate concentration of contaminants. Source: HBI Database.

This has induced building owners to shift the blame by making claims against the consultant, the contractor, and others involved in the facility's construction. But while architects and engineers to date have not been a major target of publicity or litigation arising out of IAQ issues, nevertheless, the potential scope and cost of some of the incidents have led to everyone associated with a project being blamed when the inside air of a building appears to be the cause of its occupants becoming sick. This is causing great concern among design professionals because it can ultimately result in a loss of reputation, as well as cost time and financial losses.

Because of the intense competition to maintain high occupancy rates, forward-thinking owners and managers of offices and public buildings find themselves under increasing pressure to meet or exceed the demands of the marketplace in attracting and retaining tenants. Furthermore, technological breakthroughs are bringing down the cost of facility monitoring systems and making them more affordable for a wider range of building types. By reducing the cost of facility monitoring, many financial and maintenance obstacles are removed, making permanent monitoring systems an appropriate consideration for a broader range of facilities managers. Schools, health

care facilities, and general office buildings can benefit from measuring many of the environmental conditions and use that information to respond to occupant complaints, optimize facility performance, and keep energy costs in check.

In addition, feedback from the indoor environment can be used to establish baselines for building performance and document improvements to indoor air quality. Facility monitoring systems can be valuable instruments for improving indoor air quality, identifying energy-savings opportunities, and validating facility performance. Automating the process of recording and analyzing relevant data and providing facility managers adequate access to this information can improve their ability to meet the challenge of maintaining healthy, productive indoor environments.

7.1.1 Causes of Indoor Pollution

Poor indoor air quality is usually the result of sources that release gases or particles into the air. Inadequate ventilation is generally considered the single most common cause of pollutant buildup (Fig. 7.2a) because it can increase indoor pollution levels by not bringing enough outdoor air in to dilute emissions from indoor sources and by not removing indoor air pollutants to the outside. High temperature and humidity levels can also increase concentrations of some pollutants. The second most common cause of pollutant buildup is inefficient filtration (Fig. 7.2b). But despite fundamental improvements in air filter technology, too many buildings continue to persist in relying on inefficient filters, or continue to be negligent in the maintenance of acceptable filters.

There are several factors that can trigger an investigation into indoor air quality contamination including the presence of biological growth (mold),

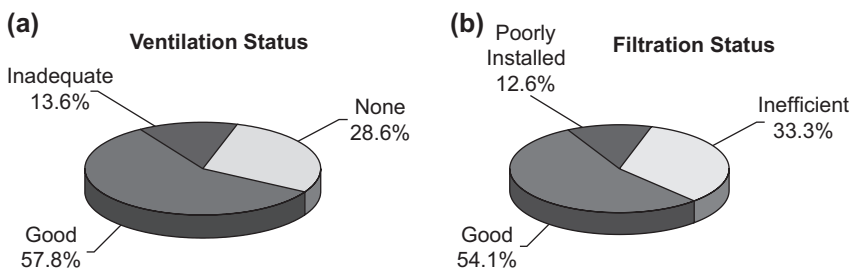

Figure 7.2 (a) Inadequate Ventilation is the single most common cause of pollutant buildup. (b) Inefficient filtration is the second most important factor in the cause of indoor pollution. *Source: HBI Database.*

unusual odors, adverse health concerns of occupants, and a variety of other symptoms or observations, such as respiratory problems, headaches, nausea, irritation of eyes, nose, or throat, fatigue, etc. Any information that is extracted from continuous monitoring can help minimize the total investigative time and expense needed to respond to occupant complaints; the information can also be used proactively in the optimization of building performance. IEQ and energy efficiency may be classified into three basic categories: (1) Comfort and ventilation, (2) Air cleanliness, and (3) Building pollutants.

Within these basic categories, facility-wide monitoring systems are available that can provide independent measurement of a range of parameters, such as temperature, humidity, total volatile organic compounds (VOCs), carbon dioxide (CO₂), carbon monoxide (CO), and airborne particulates. Unfortunately, until recently, there has been insignificant federal legislation controlling indoor air quality. This has changed with the adoption of the new International Green Construction Code (IgCC) in the United States. Also, several engineering societies such as the American society of Heating, Refrigerating, and Air-Conditioning Engineers (ASHRAE) have established guidelines which have been generally accepted by designers as minimum air design requirements for commercial buildings. ASHRAE has established two procedures for determining minimum acceptable ventilation rates. They are:

- The Ventilation Rate Procedure. This stipulates a minimum ventilation rate based on space functions within a specified building type and is based on respiration rates resulting from occupants' activities.
- The Indoor Air Quality Procedure (this requires the monitoring of certain indoor air contaminants below specified values). Air sampling techniques require the use of a device to impinge organisms from a specific volume of air and place it onto a sterile agar growth medium. The sample is then incubated for a specified period of time (say, 7 days). The colonies are then counted and the results recorded. When testing the air of a potentially contaminated area, it is best practice to have comparative samples of air from both the contaminated area and outside air of the potentially contaminated building.

7.1.2 Sick Building Syndrome

SBS describes a range of symptoms thought to be linked to spending time in a particular building, most often a workplace, but for which no specific cause can be established. Thus, SBS is when building occupants sometimes

complain of symptoms that do not appear to fit the pattern of any specific illness and which are difficult to trace to any specific source. This has been labeled SBS and is a fairly recent phenomenon. The term is used to describe situations in which building occupants experience acute health and discomfort effects that appear to be caused by time spent in a building, but often no specific illness or cause can be identified. These complaints may be localized in a particular room or zone, or may be widespread throughout the building. Research has identified the factors and symptoms that impact SBS. They include:

- thermal discomfort
- psychological stress
- noise
- headaches and dizziness
- nausea (feeling sick)
- aches and pains
- fatigue (extreme tiredness)
- shortness of breath or chest tightness
- eye and throat irritation
- irritated, blocked, or runny nose
- skin irritation (skin rashes, dry itchy skin)

It is worth noting that there are various measures that can be taken at work to help prevent the symptoms of SBS, such as:

- Open windows to avoid getting too hot
- Organize and prioritize the workload to help prevent stress
- Take regular screen breaks of a few minutes (if you use a computer) for every hour that you are sitting at your desk
- Go outside for some fresh air and a walk during lunchtime and break time
- Exercise regularly, eat healthily foods and maintain good posture.

The Environmental Protection Agency's (EPA) Indoor Air Quality Website contains pertinent information regarding strategies for identifying the causes of SBS as well as finding possible solutions to the problem. According to industry IAQ standards, SBS is diagnosed if significantly more than 20% of a building's occupants complain of adverse health effects such as headaches, eye irritation, fatigue and dizziness, etc., over a period of two weeks or more, but without a clinically diagnosable disease being identified, and the SBS symptoms disappear or are diminished when the complainant leaves the building.

7.1.3 Building-Related Illness

BRIs on the other hand are defined as a heterogeneous group of disorders whose etiology is linked to the environment of essentially modern air-tight buildings. These are typically characterized by features such as sealed windows, and dependence on heating, ventilation, and air-conditioning systems for air circulation. BRIs usually appear in nonindustrial office buildings, but it is also found in apartment buildings, single-family homes, schools, and libraries. There are two categories of BRIs, specific or non-specific. Diagnosis is based on history of exposure and clinical findings, and treatment is generally supportive.

Specific BRIs are those for which a link between building-related exposure and illness is proved. Typical examples include:

- *Legionella* infection
- Occupational asthma
- Inhalational fever
- Hypersensitivity pneumonitis

Unlike SBS, the causes of BRIs can be determined and are typically related to allergic reactions and infections. It has been known for some time that indoor environments strongly affect human health. The EPA, for example, has estimated that pollutant concentration levels (such as VOCs) inside a building may be two to five times higher than outside levels. A 1997 study by W.J. Fisk and A.H. Rosenfeld (Estimates of Improved Productivity and Health from Better Indoor Environments, *Indoor Air* 7, 158–172) estimates that the cost to the nation's workforce of upper respiratory diseases in 1995 reached \$35 billion in lost work which doesn't include an estimated additional \$29 billion in health care costs. The report suggests that by just having healthier and more efficient indoor environments, these costs could be reduced by 10–30%. To fully profit from the fiscal, physical, and psychological benefits of healthy buildings, projects need to incorporate a comprehensive, integrated design, and development process that seeks to:

- Ensure adequate ventilation
- Provide maximum access to natural daylight and views to the outdoors
- Eliminate or control sources of indoor air contamination
- Prevent water leaks and unwanted moisture accumulation, and
- Improve the psychological and social aspects of space.

The current marketplace shows that many of the building products used contain chemicals that evaporate or “off-gas” for significant periods of time after installation. When substantial quantities of these products are utilized inside a building, or products are used that have particularly

strong emissions, they pollute the indoor air and can be hazardous. Some products readily trap dust and odors and release them over time. Building materials particularly when damp can also support growth of mold and bacteria, which can cause allergic reactions, respiratory problems, and persistent odors (i.e., SBS symptoms). There are currently several environmental rating methods for buildings, but it is not always clear whether these methods assess the most relevant environmental aspects or whether other considerations lie behind the specific methods chosen. General concern for occupant health continues to increase with increased awareness and this has translated into public demand for more exacting performance requirements for materials selection and installation, improved ventilation practices, and better commissioning and monitoring protocols.

The Insurance Information Institute (III) reports a dramatic increase in IAQ-related lawsuits within the United States and that there are currently thousands of IAQ-related cases pending. This follows several lawsuits with large damage awards particularly relating to mold that have been won in recent years by building occupants suffering from health problems linked to chemicals off-gassed from building materials, that is setting legal precedents across the country. Among the primary reasons for the dramatic increase in mold claims include:

- More energy-efficient buildings with less fresh air infiltration
- Health-related issues
- Changes in building materials such as particle board, oversight board, and “synthetic stucco” or Exterior Insulation Finish Systems
- Lawyers’ awareness of billions won in bad faith or personal injury litigation
- Mold exposure scientifically linked to adverse health effects

Because of this and the flood of IAQ-related lawsuits has prompted insurance companies to reexamine their policies and their clients’ design and building methods. An effective way to reduce health risks and thus minimize potential liability is to follow a rigorous selection procedure for construction materials aimed at minimizing harmful effects to occupants.



7.2 FACTORS THAT AFFECT IEQ

USGBC says “IEQ encompasses the conditions inside a building—air quality, lighting, thermal conditions, ergonomics—and their effects on occupants or residents.” According to a report on IEQ released in July 2005, there are a growing number of people suffering from a range of

debilitating physical reactions from exposures to everyday materials and chemicals found in building products, floor coverings, cleaning products, and fragrances, among others (<http://ieq.nibs.org/>). In addition, there are those who have developed an acute sensitivity to various types of chemicals, a condition known as Multiple Chemical Sensitivity (MCS). The range and severity of these reactions vary as do the potential triggering agents.

7.2.1 Indoor Air Quality

The health and productivity of employees and tenants are greatly influenced by the quality of the indoor environment, and studies consistently reinforce the correlation between improved IEQ and occupants' health and well-being. The adverse effects to building occupants caused by poor air quality and lighting levels, the growth of molds and bacteria, off-gassing of chemicals from building materials can be significant. One of the chief characteristics of sustainable design is to support the well-being of building occupants by reducing indoor air pollution. This can best be achieved through the selection of materials with low off-gassing potential, appropriate ventilation strategies, providing adequate access to daylight and views, and providing for optimum comfort through control of lighting, temperature levels, and humidity.

Inorganic Contaminants

Inorganic substances such as asbestos, radon, and lead are among the leading indoor contaminants whose exposure can create significant health risks.

Asbestos

This is a generic term given to a variety of naturally occurring, hydrated fibrous silicate minerals that possess unique physical and chemical properties that distinguish them from other silicate minerals. Such properties include thermal, electric, and acoustic insulation, chemical and thermal stability, and high tensile strength, all of which have contributed to their wide use by the construction industry (Table 7.1). Yet, though banned in certain products and uses, this mineral continues to pose a significant health threat. High concentrations of airborne asbestos can occur during demolition and after asbestos-containing materials are disturbed by cutting, sanding, and other activities. Asbestos-containing materials are also found in concealed areas such as wall cavities, below ground level, and other hidden spaces. In many older establishments, asbestos-based insulation was used on heating pipes and on the boiler. An adequate Asbestos Survey requires the Inspector to perform destructive testing (i.e., opening walls, etc.) to inspect areas likely to contain suspect materials.

Table 7.1 Partial list of materials that may contain asbestos**Sample asbestos-containing material list**

Acoustical ceiling texture	Gray roofing paint
Asphalt flooring	High-temperature gaskets
Base flashing	HVAC duct insulation
Blown-in insulation	Incandescent light fixture backing
Boiler/tank insulation	Joint compound/wallboard
Breaching insulation	Laboratory hoods/tabletops
Brick mortar	Laboratory fume hood
Built-up roofing	Mudded pipe elbow insulation
Caulking/putties	Nicolet (white) roofing paper
Ceiling tiles/panels/mastic	Packing materials
Cement board	Paper fire box in walls
Cement pipes	Pipe insulation/fittings
Cement roofing shingles	Plaster/wall joints
Chalkboards	Poured flooring
Construction mastics	Rolled roofing
Duct tape/paper	Roofing shingles
Ductwork flexible connections	Sink insulation
Electrical cloth	Spray-applied insulation
Electrical panel partitions	Stucco
Electrical wiring insulation	Subflooring slip sheet
Elevator brake shoes	Textured paints/coatings
Fire blankets	Vapor barrier
Fire curtains/hose	Vermiculite
Fire doors	Vinyl floor tile/mastic
Fireproofing	Vinyl sheet flooring/mastic
Furnace insulation	Vinyl wall coverings

Note: This is a sample list of products that may contain asbestos. It is intended as a general guide to show which types of materials may contain asbestos and is not all inclusive.

The EPA and US Consumer Product Safety Commission have also banned several asbestos products. But asbestos-containing material became more of a high-profile public concern after federal legislation known as Asbestos Hazard Emergency Response Act was enacted in 1987. Today, asbestos can still be found in older homes, in pipe and furnace insulation materials, asbestos shingles, millboard, textured paints and other coating materials, and floor tiles. Asbestos is considered the most widely recognized environmentally regulated material during building evaluations.

Health Hazards: The risk of airborne asbestos fibers is generally low when the material is in good condition. However, when the material becomes damaged or if it is located in a high activity area (family room, work shop, laundry, etc.), the risk increases. Increased levels of exposure to airborne

asbestos fibers will cause disease. When these fibers get into the air, they may be inhaled and remain and accumulate in the lung tissue, where they can cause substantial health problems including lung cancer, mesothelioma (a cancer that attacks the chest and abdominal linings), and asbestosis (irreversible lung scarring that can be fatal). Symptoms of these diseases do not show up until many years after exposure began. Studies show that people with asbestos-related diseases were usually exposed to elevated concentrations on the job although some developed disease from exposure to clothing and equipment brought home from job sites. While the process is slow, and years may pass before health problems are evidenced (Thus, it could be at least 10 years or more before asbestosis occurs, or several decades before symptoms of cancer emerge), the result and, thus, the risk are well established.

Radon

Radon is a natural colorless (at ordinary temperatures), odorless, tasteless, radioactive soil gas, i.e., that is emitted from the soil as a carcinogenic by-product of the radioactive decay of radium-226. Radon is the heaviest known gas (atomic number 86) and is often found associated with uranium ores. Radon also exists as a dissolved gas in some spring waters (e.g., those at Hot Springs, Arkansas, USA). The by-product can, however, cling to dust particles which when inhaled, settle in bronchial airways. Generally, radon is drawn into a building environment by the presence of air pressure differentials. The ground beneath a building is typically under higher pressure than the basement or foundation. Air and gas move from high-pressure areas to low-pressure areas. The gas can enter the building through cracks in walls and floors, as well as penetrations associated with plumbing, electrical openings, sump wells, etc., in building spaces coming in close contact with uranium-rich soil. Vent fans and exhaust fans also facilitate to put a room under negative pressure and increase the draw of soil gas, which can increase the level of radon within a building.

Radon exposure becomes a concern when it becomes trapped in buildings and indoor levels of concentrations buildup, which is why adequate ventilation is necessary to prevent the gas from accumulating in buildings to dangerous levels as this can pose a serious health hazard. Where radon is suspected, a survey should be conducted to measure the concentrations of radon in the air and determine whether any actions will be required to reduce the contamination. Radon levels will vary from region to region, season to season, and one building to another. Radon levels are typically at their highest during the coolest part of the day when pressure differentials are at their greatest.

High concentration of radon in the air is often an indication of possible radon contamination of the water supply (if a private water supply is present). In this case, a water test for radon is the prudent first step. Should high concentrations of radon be found in the water, then an evaluation of ventilation rates in the structure as well as air quality tests for radon would be highly recommended. Generally speaking, high radon concentrations are more likely to exist where there are large rock masses, such as in mountainous regions. The United States EPA recommends that buildings should be tested every few years to assess the safety of radon levels.

Radon Mitigation: Everything being equal, elevated radon levels should not necessarily deter investors from purchasing a property, as the problem can usually be easily resolved—even in existing buildings, without having to incur great expense. However, lowering high radon levels requires technical knowledge and special skills which means a trained radon reduction contractor who understands how to fix radon problems should be used. The EPA has published several brochures and instructional aides regarding radon-resistant construction. This is perhaps the most cost-effective way to handle a radon problem, as it is easier to build the system into the building rather than retrofit it later. Also, EPA studies suggest that elevated radon levels are more likely to exist in energy-efficient buildings than otherwise. If your building has a radon system built in, the EPA recommends periodic testing to ensure that the system is working properly and that the radon level in your building has not changed.

Health Risks: The principal health hazard associated with exposure to elevated levels of radon is lung cancer. Research suggests that while swallowing water with high radon levels may also pose risks, these are believed to be much lower than those from breathing air containing radon. However, the real threat is not so much from the radon gas itself but from the products that it produces such as lead, bismuth, and polonium when it decays. The risk is greatest for people with diminished lung capacity, asthma sufferers, and smokers, and so on. And although energy-efficient construction may save energy bills, it may also increase occupants' exposure to radon and other indoor air pollutants.

Radon Testing Methods: There are many methods that can be used for Radon testing. For short-term testing, consultants typically use electret ionization chambers which generally last about a week. The chambers method work by incorporating a small charged Teflon plate screwed into

the bottom section of a small plastic chamber. When the radon gas enters the chamber, it begins to decay and creates charged ions that deplete the charge on the Teflon plate. By registering the voltage prior to deployment and then reading the voltage upon recovery, a mathematical formula is used to calculate the radon concentration levels within the building. Thus fortunately, Radon detection devices are commercially available, and the short-term radon test devices used for screening purposes are generally inexpensive, and sometimes free.

Lead

Lead is a highly toxic metal found in products including paint, ceramics, pipes, solders, gasoline, batteries, and cosmetics. Since 1980, federal and state regulatory standards have helped to minimize or eliminate the amount of lead in consumer products and occupational settings. In fact, for several decades, lead has been known to be a harmful environmental pollutant and in late 1991, the Secretary of the Department of Health and Human Services described lead as the “*number one environmental threat to the health of children in the United States.*” There are many ways in which humans may get exposed to lead: as mineral particles in ambient air, drinking water, food, contaminated soil, deteriorating paint, and dust. Lead is a heavy metal and does not break down in the environment and continues to be used in many materials and products to this day. Lead is a natural element and most of the lead in use today is inorganic lead, which enters the body when an individual breathes (inhales) or swallows (ingestion) lead particles or dust once it has settled. Lead dust or particles cannot penetrate the skin unless the skin is broken. Organic lead, however, such as the type used in gasoline can penetrate the skin.

Lead Levels in the Indoor Environment: Because of its widespread use and the nature of individual uses, lead has for some time been known to be a common contaminant of interior environments. For centuries, lead compounds like white lead and lead chromate have been used as white pigments in commercial paints. In addition to their pigment properties, these lead compounds were valued because of their durability and weather resistance which made their use more viable particularly in exterior white paints.

The most common sources of lead exposure in the United States today consist mainly of old lead-based paint found in older homes, and old piping, contaminated soil, household dust, drinking water, lead crystal, and lead-glazed pottery. One of Lead-based paint’s main characteristics is that it can

begin to flake and peel as it ages, and can also become airborne, or ingested which can lead to serious health problems; this is of grave concern since the majority of homes and buildings built before 1960 contained heavily leaded paint. Even as recently as 1978, there were homes and buildings that used lead paint. This paint may have been used on window frames, walls, the building's exterior, or other surfaces. Because of potentially serious health hazards and negative publicity, lead content was gradually reduced until it was banned altogether in 1978 (in the United States). In commercial buildings, lead was used primarily as a paint preservative.

Although lead piping has sometimes been used in older buildings, it was not legally required to be replaced, which is why it can create a health hazard because the piping is frequently found to be deteriorating and leaching into the building's drinking water. In some buildings, lead solder has also been used in copper pipes installation, but in most jurisdictions, this procedure has now been banned due to water contamination resulting from the deterioration of the solder. The potential for water contamination can often be removed by chemical treatment of the water. Where this cannot be accomplished, the piping may have to be replaced.

Unfortunately, lead is still allowed in paint for bridge construction and machinery and thus remains a significant source of exposure. Its continued use is mainly due to its ability to resist corrosion and its ability to expand and contract with the metal surface of a structure without cracking. But even if its use were banned today, there would still be potential exposure to workers and surrounding communities for many years to come because of the many metal structures, such as bridges, that have been coated with it.

Health Risks: Lead is a highly toxic substance that affects a variety of target organs and systems within the body including the brain and the central nervous system, renal, reproductive, and cardiovascular systems. High levels of lead exposure can cause convulsions, coma, and even death. However, the nervous system appears to be the main target organ system for lead exposure. Effects of lead poisoning depend largely on dose exposure. Contact with lead-contaminated dust is the primary method in which most children are exposed to harmful levels of lead. Pregnant women, infants, and children are more vulnerable to lead exposure than adults because lead is more easily absorbed into growing bodies, and the tissues of small children are more sensitive to the damaging effects of lead. In adults, high lead levels have many adverse effects, including causing kidney damage, digestive problems, high blood pressure, headaches, diminishing memory and concentration, mood changes, nerve disorders, sleep disturbances, and muscle

or joint pain. Likewise, lead can seriously impact the ability of both men and women to bear healthy children.

Lead Paint Testing: Various testing methods and procedures can be used to identify the presence of lead paint. In the field, the most widely applied method is the use of an X-ray Fluorescent lead-in-paint analyzer (XRF). The XRF analyzer is normally held up to the surface being tested for several seconds. The analyzer then emits radiation which is absorbed and then fluoresces (is emitted) back to the analyzer. The XRF unit breaks down the signals to determine if lead is present and if so, in what concentration. An XRF analyzer can normally read through up to 20 layers of paint, but it is expensive, and should only be used by trained professionals.

Combustion-Generated Contaminates

Combustion (burning) by-products are essentially gases and tiny particles that are created by the incomplete burning of fuels. And there are many combustion by-products including, fine particulate matter, carbon monoxide (CO), nitrogen oxides, and tobacco smoke. These fuels (such as natural gas, propane, kerosene, fuel oil, coal, coke, charcoal, wood, and gasoline, and materials such as tobacco, candles, and incense), when burned, produce a wide variety of air contaminants. If fuels and materials used in the combustion process were free of contaminants and combustion were complete, emissions would have been limited to carbon dioxide (CO₂), water vapor (H₂O), and high-temperature reaction products formed from atmospheric nitrogen (NO_x) and oxygen (O₂). Sources of combustion-generated pollutants in indoor environments are many and include wood heaters and woodstoves, furnaces, gas ranges, fireplaces, and car exhaust (in an attached garage). Other combustion-generated contaminants include respirable particles, aldehydes such as formaldehyde (HCHO) and acetaldehyde, as well as a number of VOCs; fuels and materials containing sulfur will produce sulfur dioxide (SO₂). Particulate-phase emissions may include tar and nicotine from tobacco, creosote from wood, inorganic carbon, and polycyclic aromatic hydrocarbons.

Carbon Dioxide

Carbon Dioxide is a colorless, odorless, heavy, incombustible gas that is found in the atmosphere and formed during respiration. It is typically obtained from the burning of gasoline, oil, kerosene, natural gas, wood, coal, and coke. It is also obtained from carbohydrates by fermentation, by reaction of acid with limestone or other carbonates, and naturally from

springs. CO₂ is absorbed from the air by plants in a process called photosynthesis. Although carbon dioxide is not normally a safety problem, a high CO₂ level can indicate poor ventilation which in turn can lead to a buildup of particles and more harmful gases such as carbon monoxide that can negatively impact people's health and safety. CO₂ is used extensively in industry as dry ice, or carbon dioxide snow, in carbonated beverages, fire extinguishers, and so on.

Carbon Monoxide

Carbon Monoxide is an odorless, colorless, lighter than air, nonirritating gas that interferes with the delivery of oxygen throughout the body and which can kill you. CO is the leading cause of poisoning deaths in the United States and occurs when there is incomplete combustion of carbon-containing material such as coal, wood, natural gas, kerosene, gasoline, charcoal, fuel oil, fabrics, and plastics. CO can build up indoors and poison people and animals who breathe it. CO is typically found in fumes produced any time fuel is burned in cars or trucks, small engines, stoves, lanterns, grills, fireplaces, gas ranges, or furnaces. And the fact that CO cannot be seen, smelled, or tasted makes it especially dangerous because one is not aware of being poisoned. Moreover, doctors frequently misdiagnose CO poisoning. The most common indicators of CO poisoning are headache, dizziness, weakness, chest pain, upset stomach, vomiting, and confusion. CO symptoms are frequently described as "flu-like." Breathing in a large quantity of CO can cause unconsciousness or death. And persons who are sleeping or drunk can die from CO poisoning before they have symptoms. Particularly at risk for CO poisoning are infants, the elderly, and persons with chronic heart disease, anemia, or breathing problems.

Testing methods for Carbon Monoxide: The only reliable method currently used to test for the presence of carbon monoxide is an electronic device known as a carbon monoxide alarm. In the home, CO detectors should be placed in areas where the family spends most of its time such as the family room, bedroom, or kitchen, but placed far enough away from obvious and predictable sources of CO, such as a gas stove, to avoid false alarms.

Nitrogen Dioxide

Nitrogen Dioxide (NO₂) is a colorless, odorless gas that irritates the mucous membranes in the eye, nose, and throat and causes shortness of breath when exposed to high concentrations. Documented evidence also indicates that

high concentrations or continued exposure to low levels of nitrogen dioxide increases the likelihood of respiratory problems. Because nitrogen dioxide is relatively insoluble in tissue fluids, it enters the lungs, where it may expose lower airways and alveolar tissue. Nitrogen dioxide inflames the lining of the lungs and can reduce immunity to lung infections. Likewise, documented evidence from animal studies shows that repeated exposures to elevated nitrogen dioxide levels may lead, or contribute, to the development of lung diseases such as emphysema. Excessive exposure can cause problems such as wheezing, coughing, colds, flu, and bronchitis and can also have significant impacts on people with asthma because it can cause more frequent and more intense attacks. People at particular risk from exposure to nitrogen dioxide include children with asthma and older people with heart disease or other respiratory diseases. Nitrogen dioxide is also a major concern as an air pollutant because it contributes to the formation of photochemical smog, which can have significant impacts on human health.

Organic Contaminants—Aldehydes, VOCs/Semivolatile Organic Compounds, Pesticides

Modern industrialized societies have developed such a massive array of organic pollutants that it is becoming increasingly difficult to generalize in a meaningful way as to sources, uses, or impacts. The main organic compounds include VOCs, the very volatile organic compounds (VVOCs), semivolatile organic compounds (SVOCs), and particulate organic materials (POMs). POMs may comprise components of airborne or surface dusts. Organic compounds often pose serious indoor contamination problems and include the aldehydes, VOCs/SVOCs, which include a large number of volatile as well as less volatile compounds, and pesticides and biocides which are largely SVOCs. Organic compounds that are known to be contaminants of indoor environments include a large variety of aliphatic hydrocarbons, aromatic hydrocarbons, oxygenated hydrocarbons (such as aldehydes, ketones, alcohols, ethers, esters, and acids), and halogenated hydrocarbons (primarily chlorine and fluorine containing). VOC concentration levels are generally higher in indoor environments than in outdoor air.

In recent years, we have witnessed a steady increase in the number of identified VOCs. They are characterized by a wide range of physical and chemical attributes—the most important of which are their water solubility and whether they are neutral, basic, or acidic. VOCs are released into the indoor environment by extensive sources. VOCs pose many health hazards such as being potent narcotics that cause a depression in the central nervous

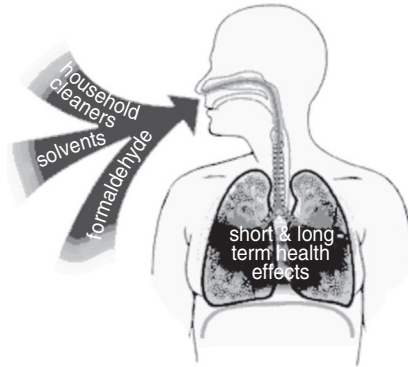

Figure 7.3 Diagram showing inhalation of volatile organic compounds. *Source: Air Advice Inc., Portland, OR.*

system and others can cause eye, nose, and throat irritation; headaches; loss of coordination; nausea; and damage to the liver, kidneys, and central nervous system (Fig. 7.3). A number of these chemicals are suspected or known to cause cancer in humans.

Formaldehyde

Formaldehyde (HCHO), also known as urea-methanal, is a colorless, pungent-smelling gas, and one of the more common VOCs found indoors and which is an important chemical used widely by industry to manufacture building materials and numerous household products. Additionally, it is a nontransparent thermosetting resin or plastic, made from urea and formaldehyde heated in the presence of a base. It is also a by-product of combustion and certain other natural processes and thus, may be present in substantial concentrations both indoors and outdoors. On condensing, it forms a liquid with a high vapor pressure, and due to its high reactivity, it rapidly polymerizes with itself to form paraformaldehyde. Formaldehyde, by itself or in combination with other chemicals, serves a number of purposes in manufactured products such as a component of glues and adhesives, and as a preservative in some paints and coating products.

Some of the attributes of urea-formaldehyde (UF) resin include high tensile strength, flexural modulus, and heat distortion temperature, low water absorption, mold shrinkage, high surface hardness, and volume resistance. UF copolymeric resins are present in many building materials such as wood adhesives which are used in the manufacture of pressed wood products including particle board, medium-density fiber board (MDF), plywood, finish coatings (acid-cured), textile treatments, as well as in the production of UF

foam insulation (UFFI). However, most people are unaware that formaldehyde is given off by materials other than UFFI. Certain types of pressed wood products (composition board—e.g., MDF, paneling, etc.), carpeting, and other material can be formaldehyde sources. Many of these products use a UF-based resin as an adhesive. Some of these materials will continue to give off formaldehyde much longer than UFFI. Like the majority of VOCs, formaldehyde levels will decrease substantially with time and/or with increased ventilation.

Health Risks: For some people, formaldehyde can be a respiratory irritant, and continuous exposure to it can be dangerous. More specifically, chronic, low-level, continuous, and even intermittent exposure to formaldehyde can cause chemical hypersensitivity and provides an accelerating factor in the development of chronic bronchitis and pulmonary emphysema. This has caused considerable concerns about the risks of cancer and bronchial health impacts from formaldehyde. These concerns and several market factors are driving major changes in the composition and technology of these resins. In addition, significant pressure from the green building movement through market selection and certification programs, plus emissions regulations from the California Air Resources Board, has moved manufacturers to seek new ways to reduce formaldehyde emissions or eliminate formaldehyde entirely from formulas. It should be noted that upon condensing, HCHO forms a liquid with a high vapor pressure. Due to its high reactivity, it rapidly polymerizes with itself to form paraformaldehyde. Because of this reaction, liquid HCHO needs to be kept at a low temperature or mixed with a stabilizer (such as methanol) to prevent or minimize polymerization.

Polychlorinated Biphenyls

Polychlorinated Biphenyls (PCBs) are oils used primarily as a coolant in electrical transformers. Although production and sale of PCB was banned by the EPA in 1979, a large number of PCB-filled transformers remain in use. It has also been estimated that some 2,000,000 mineral oil transformers still contain some percentage of PCB. PCBs may also be found in light ballasts and elevator hydraulic fluids. PCBs are a suspected carcinogen, but if properly sealed or contained, they do not pose a hazard.

Hydrocarbons

Hydrocarbons are a class of organic chemical compounds consisting only of the elements hydrogen (H) and carbon (C) and are a colorless, flammable, toxic liquid. They are cardinal to our modern way of life and its quality and

being one of the Earth's most important energy resources. Hydrocarbons are the principal constituents of petroleum, natural gas, and are also derived from coal. The bulk of the world's hydrocarbons are used for fuels and lubricants, as well as for electrical power generation and heating.

Many of the symptoms associated with exposure to aliphatic hydrocarbons may include watery eyes, nausea vomiting, dizziness, weakness, central nervous system effects such as depression, convulsions and, in extreme cases, coma. Other symptoms may include pulmonary and gastrointestinal irritation, pulmonary edema, bronchial pneumonia, anorexia, anemia, nervousness, pain in the limbs, and numbness. Benzene is found in most hydrocarbons and is considered to be one of the more serious contaminants and is known to cause leukemia. Air quality tests may be necessary as well as tests for contaminants in the soil around the foundation.

Pesticides

Pesticides are chemical poisons, designed to control, destroy or repel plants and animals such as insects (insecticides), weeds (herbicides), rodents (rodenticides), and mold or fungus (fungicides). They include active ingredients (those intended to kill the target) and inert ingredients, which are often not "inert" at all. Pesticides are generally toxic and can be absorbed through the skin, swallowed, or inhaled and as such are unique contaminants of indoor environments. Studies show that approximately 16 million Americans are sensitive to pesticides, because their immune systems have been damaged as a result of prior pesticide exposure. In addition, pesticides have been linked to a wide range of serious and often fatal conditions: cancer, leukemia, miscarriages, genetic damage, decreased fertility, liver damage, thyroid disorders, diabetes, neuropathy, still births, decreased sperm counts, asthma, and other autoimmune disorders (lupus, etc.).

Pesticides are carefully regulated by the Federal Government, in cooperation with the States, to ensure that they do not pose unreasonable risks to human health or the environment. There are currently more than 1055 active ingredients registered as pesticides, which are formulated into thousands of different pesticide products that are available in the marketplace including some of the most widely used over the past 60 years that are persistent and have become globally distributed.

According to the EPA, "The process of registering a pesticide is a scientific, legal, and administrative procedure through which we examine the ingredients of the pesticide; the particular site or crop where it is to be used; the amount, frequency, and timing of its use; and storage and disposal

practices. In evaluating a pesticide registration application, we assess a wide variety of potential human health and environmental effects associated with use of the product. The company that wants to produce the pesticide must provide data from studies that comply with our testing guidelines.”

The EPA also states that “Potential human risks range from short-term toxicity to long-term effects such as cancer and reproductive system disorders.” These include aldrin, chlordane, dichlorodiphenyltrichloroethane, dieldrin, endrin, heptachlor, mirex, toxaphene, and lindane (hexachlorocyclohexane, HCH). Many pesticides (most notably chlordane, used for termite treatment) are serious hazards. It is hoped that ecological methods of pest control will in the future replace the overdependence on chemicals that now threatens our ecosystem. The EPA regulates “pesticides under broad authority granted in two major statutes, the Federal Insecticide, Fungicide, and Rodenticide Act and the Federal Food, Drug, and Cosmetic Act. These laws have been amended by the Food Quality Protection Act and the Pesticide Registration Improvement Act.”

Biological Contaminants

Mold and mildew, viruses, bacteria, and exposures to mite, insect, and animal allergens are biological pollutants arising from various sources such as microbiological contamination (e.g., fungi, bacteria, viruses), mites, pollens, and the remains and dropping of pests such as cockroaches. Of particular concern are those biological contaminants that cause immunological sensitization manifested as chronic allergic rhinitis, asthma, and hypersensitivity pneumonitis. Pollutants of biological origin can also significantly impact indoor air quality and cause infectious disease through airborne transmission.

One of the major contributors to poor indoor air quality, mold growth, and unhealthy buildings is the presence of moisture, but by controlling the relative humidity (RH) level, the growth of some sources of biologicals can be minimized. Standing water, water-damaged materials, rainwater leaks, or wet surfaces also serve as a breeding ground for molds, mildews, bacteria, and insects as well as contaminated central HVAC systems which can then distribute these contaminants through the building.

A method often used for deterring rainwater intrusion into walls is the rain screen approach, which incorporates cladding, air cavity, drainage plane, and airtight support wall to offer multiple moisture-shedding pathways. The concept of the rain screen principle is simple; it is to separate the plane in a

wall where the rainwater is shed and where the air infiltration is halted. In terms of construction, this means that there is an outer plane which sheds rainwater but allows air to freely circulate, and an inner plane which is relatively airtight.

Mold and Mildew

Mold and Mildew are forms of musty smelling fungi that thrive in moist environments. Their function in nature is primarily to break down and decompose organic materials such as leaves, wood, and plants. They grow, penetrate, and infect the air we breathe. There are thousands of species of molds which include pathogens, saprotrophs, aquatic species, and thermophiles. Molds are part of the natural environment growing on dead organic matter and are present everywhere in nature; their presence is only visible to the unaided eye when mold colonies grow (Table 7.2).

Different mold species will vary enormously in their tolerance to temperature and humidity extremes. The key to controlling indoor mold

Table 7.2 Table showing partial list of typical types of molds found in damp buildings

Fungal species	Substrate	Possible metabolites	Potential health effects
<i>Alternaria alternata</i>	Moist window-sills, walls	Allergens	Asthma, allergy
<i>Aspergillus versicolor</i>	Damp wood, wallpaper glue	Mycotoxins, VOCs	Unknown
<i>Aspergillus fumigatus</i>	House dust, potting soil	Allergens	Asthma, rhinitis, hypersensitivity pneumonitis
		Many mycotoxins	Toxic pneumonitis infection
<i>Cladosporium herbarum</i>	Moist window-sills, wood	Allergens	Asthma, allergy
<i>Penicillium chrysogenum</i>	Damp wallpaper, behind paint	Mycotoxins	Unknown
		VOCs	Unknown
<i>Penicillium expansum</i>	Damp wallpaper	Mycotoxins	Nephrotoxicity?
<i>Stachybotrys chartarum (atra)</i>	Heavily wetted carpet, gypsum board	Mycotoxins	Dermatitis, mucosal irritation, immunosuppression

VOCs, volatile organic compounds.

Source: California Department of Health Services, Environmental Health Investigations Branch.

growth is to control moisture content, and the temperatures of all surfaces, including interstitial surfaces within walls. Mold generally needs a temperature range between 40°F and 100°F to grow, and maintaining RH levels between 30% and 60% will help control mold and many of these known biological contaminants. Winter humidification and summer dehumidification controls/modules can supplement central HVAC systems when climate excesses require additional conditioning measures.

Exposure to fungus in indoor air settings has emerged as a significant health problem of great concern in both residential environments as well as in workplace settings. Fungi are primitive plants that lack chlorophyll and therefore feed on organic matter that they digest externally and absorb or must live as parasites. True fungi include yeast, mold, mildew, rust, smut, and mushrooms. When mold spores land on a damp spot indoors, they can grow and start digesting whatever they are growing on.

Four vital elements are needed for mold to grow, they are: viable spores, a nutrient source (organic matter like wood products, carpet, and drywall), moisture, and warmth. The mere presence of humid air in itself is not necessarily conducive to fostering mold growth, except where air has an RH level at or above 80% and is in contact with a surface. Mold spores are carried by air currents and can reach all surfaces and cavities of buildings. When the surfaces and/or cavities are warm and contain the right nutrients and amounts of moisture, the mold spores will grow into colonies and gradually destroy the things they grow on. Likewise by removing any of the four essential growth elements, the growth process is inhibited or nonexistent.

To execute a mold remediation project, the first step requires determining the root cause of the mold growth. The next step is to evaluate the order of magnitude of the mold growth, which is usually done through visual examination. Since old mold growth may not always be visible, investigators may need to use instruments such as moisture meters, thermal imaging equipment, or borescope cameras to identify moisture in building materials or “hidden” mold growth within wall cavities, HVAC ducts, etc. Toxic molds and fungi are a significant source of airborne VOCs that create IAQ problems as can be seen in [Fig. 7.4](#). Toxicity can arise from inhalation or skin contact with toxigenic molds. Some molds produce toxic liquid or gaseous compounds, known as mycotoxins, in addition to infectious airborne mold spores which often cause serious health problems to residents and workers.

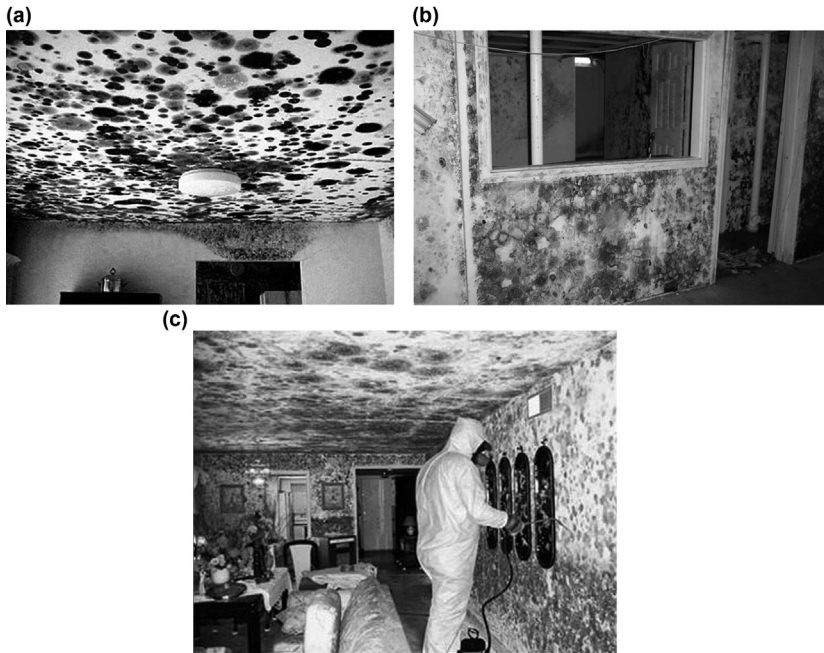

Figure 7.4 (a) Example of mold on a ceiling that is growing out of control which can be found in damp buildings. (b) Example of mold on a wall that has grown out of control. (c) Example of an extreme case of toxic mold growth in the process of being treated. *Courtesy: Applied Forensic Engineering, LLC. (a) Source: mold-kill.com.*

Bacteria and Viruses

Many millions of people around the globe suffer daily from viral infections of varying degrees of severity and at immense cost to the economy including the costs for medical treatment of infected people, costs of lost income due to inability to work, and costs of decreased productivity of those who are infected. In fact, viruses have been identified as the most common cause of infectious diseases acquired within indoor environments, particularly those causing respiratory and gastrointestinal infection. The most common viruses causing respiratory infections include influenza viruses, rhinoviruses, corona viruses, respiratory syncytial viruses, and parainfluenza viruses; whereas viruses responsible for gastrointestinal infections include rotavirus, astrovirus, Norwalk-like viruses. Some of these infections like the common cold are very widely spread but are not severe, while infections like influenza are relatively more serious.

While bacteria cause bacterial infections, viruses cause viral infections. And while antibiotic drugs usually kill bacteria, they are not effective against viruses. Examples of infections caused by bacteria include strep throat, tuberculosis, and urinary tract infections. Common diseases caused by viruses include chicken pox, AIDS, and common colds. In some cases, it may be difficult to determine whether a bacterium or a virus is causing a person's symptoms. Many ailments such as pneumonia, meningitis, and diarrhea can be caused by either type of microbe.

Bacteria and viruses are minute in size and readily become airborne and remain suspended in air for hours which makes them a cause of considerable concern due to their ability to transmit infectious diseases. While there are many methods for the infection to spread, the most significant, from an epidemiological point of view is airborne transport. Microorganisms can become airborne when droplets are given off during speech, coughing, sneezing, vomiting, or atomization of feces during sewage removal. Q fever (also known as query fever), which is a bacterial infection caused by the bacteria *Coxiella burnetii*, is another emerging infectious disease among US soldiers serving in Iraq.

Liquid and solid airborne particles (aerosols) in indoor air originate from many indoor and outdoor sources. These particles may differ in size, shape, chemical composition, and biological composition. Particle size signifies the most important characteristic affecting particle fate during transport and it is also significant in affecting their biological properties. Bacterial aerosols have also been found to be a means to transmit a number of major diseases as shown in [Table 7.3](#) below:

According to Professor Lidia Morawska of Queensland University of Technology in Australia, the degree of hazard created by biological contaminants including viruses in indoor environments is controlled by a number of factors like:

- The type of virus and potential health effects it causes
- Mode of exit from the body

Table 7.3 Major infectious diseases associated with bacterial aerosols

Disease	Causal organism
Tuberculosis	<i>Mycobacterium tuberculosis</i>
Pneumonia	<i>Mycoplasma pneumoniae</i>
Diphtheria	<i>Corynebacterium diphtheriae</i>
Anthrax	<i>Bacillus anthracis</i>
Legionnaires' disease	<i>Legionella pneumophila</i>
Meningococcal meningitis	<i>Neisseria meningitidis</i>
Respiratory infections	<i>Pseudomonas aeruginosa</i>
Wound infections	<i>Staphylococcus aureus</i>

Table 7.4 Some of the major infectious diseases associated with viral aerosols

Disease	Virus/bacteria type
Influenza	<i>Orthomyxovirus</i>
Cold	<i>Coronavirus</i>
Measles	<i>Paramyxovirus</i>
Rubella	<i>Togavirus</i>
Chicken pox	<i>Herpes virus</i>
Respiratory infection	<i>Adenovirus</i>

- Concentration levels
- Size distribution of aerosol containing the virus
- Physical characteristics of the environment (temperature, humidity, oxygenation, UV light, Suspension medium, etc.)
- Air-circulation pattern
- Operation of heating, ventilation, and air-conditioning system.

The physical characteristics of the indoor environment as well as the design and operation of building ventilation systems are of paramount importance. Ducts, coils, and recesses of building ventilation systems often provide fertile breeding grounds for viruses and bacteria that have been proven to cause a wide range of ailments from influenza to tuberculosis. Likewise, a number of viral diseases may be transmitted in aerosols derived from infected individuals. A number of infectious viral diseases and associated causal viruses transmitted through air are shown below in [Table 7.4](#).

Rodent, Insect, and Animal Allergens

The Illinois Department of Public Health, a typical large city in the United States says it annually receives more than 10,000 complaints about rodent problems and performs tens of thousands of rodent control inspections and baiting services. Effective measures need be taken to prevent entry by rodents, insects, and pests from entering the home or office. Cockroaches, rats, termites, and other pests have plagued commercial facilities for far longer than computer viruses. According to the National Pest Management Association, pests can cause serious threats to human health, including such diseases as rabies, salmonellosis, dysentery, and staph. But in addition to pests presenting a serious health concern to a building's occupants, they also distract from a facility's appearance and value.

Rats

Large communities of rats exist today within and beneath cities, traveling unnoticed from one building to another, along sewers and utility lines. Each

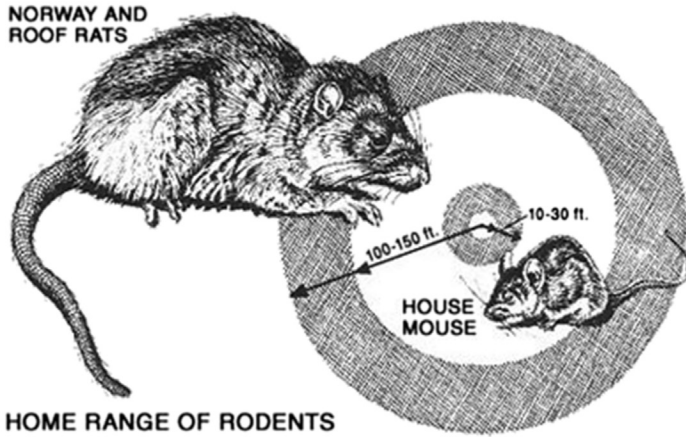

Figure 7.5 Drawing showing typical home range of rodents. *Source: Illinois Department of Public Health.*

rat colony has its own territory, which can span an entire city block and harbor more than 100 rats. As they explore their territories, rats and mice discover new food sources and escape routes. A rat’s territory or “home range” is generally within a 50-foot to 150-foot radius of the nest, while mice usually have a much smaller range, living within a 10-foot to 30-foot radius of the nest (Fig. 7.5). In places where all their needs (food, water, shelter) are met, rodents have smaller territories.

Insects

Today, more than 900,000 species of insects have been identified and additional species are being identified everyday. Some of these insects are known sources of inhalant allergens that may cause chronic allergic rhinitis and/or asthma. They include cockroaches, crickets, beetles, moths, locusts, midges, termites, and flies. Insect body parts are especially potent allergens for some people. Cockroach allergens are also potent allergens and are commonly implicated as contributors to SBS in urban housing and facilities with poor sanitation. Most of the allergens from cockroaches come from the insect’s discarded skins (Fig. 7.6). As the skins disintegrate over time, they become airborne and are inhaled. Cockroaches have been reported to spread at least 33 kinds of bacteria, 6 kinds of parasitic worms, and at least 7 other kinds of human pathogens.

Mites: Mites are microscope bugs that thrive on the constant supply of shed human skin cells (commonly called dander) that accumulate on carpeting, drapes, furniture coverings, and bedding (Fig. 7.7). The proteins in that combination of feces and skin shedding are what cause allergic reactions in

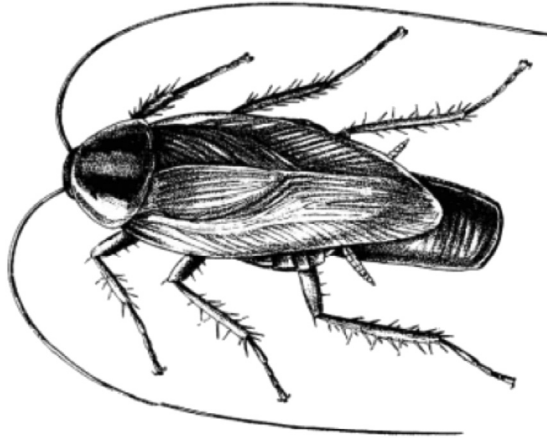

Figure 7.6 Drawing of an American cockroach.

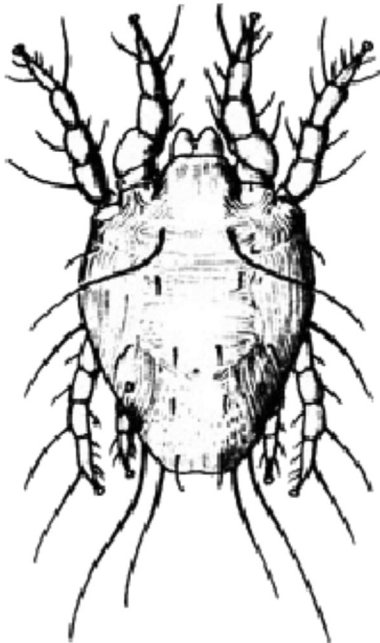

Figure 7.7 Drawing of a dust mite. *Source: EHSO.*

humans. Dust mites are perhaps the most common cause of perennial allergic rhinitis. Dust mites are the source of one of the most powerful biological allergens and flourish in damp, warm environments. It is estimated that up to 15% of people are allergic to dust mites which due to their very small size

(250–300 μm in length) and translucent bodies, are not visible to the naked eye. To be able to give an accurate identification, one needs at least a 10 \times magnification. Dust mites have eight hairy legs, no eyes or antennae, and a mouthpart group in front of the body (resembles head) and a tough, translucent shell. Dust mites have multiple developmental stages, commencing with an egg, then developing into larva, followed by several nymph stages, and finally the adult. They also prefer warm, moist surroundings like the inside of a mattress particularly when someone is lying on it, but they may also accumulate in draperies, carpet, and other areas where dust collects. The favorite food of mites appears to be dander (both human and animal skin flakes). Humans generally shed about 1/5 ounce of dander (dead skin) a week. Dust mite populations are usually highest in humid regions and lowest in areas of high altitude and/or dry climates.

Ants: Ants are found throughout the United States, although species found in different regions of the country vary. There are in excess of 20 varieties of ants invading homes and offices throughout the United States, particularly during the warm months of the year (Fig. 7.8). Worldwide, there are more than 12,000 species, but of these, only a limited number actually cause problems. Among the more common ant species in the United States are the Argentine, Odorous House, Carpenter, Fire, Pavement, and Pharaoh Ants. Destructive ant species include fire and carpenter ants. Fire ants are vicious, unrelenting predators and have a powerful, painful sting. More than 32 deaths in the United States have been attributed to severe allergic reactions to fire ant stings. Ant infestations are more likely to occur in single-family dwellings, because colonies usually nest outdoors and will only come inside in search of food or water.

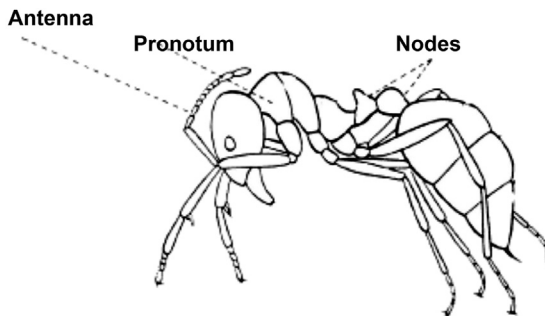

Figure 7.8 Illustration identifying primary features of an ant.



Termite

Figure 7.9 Illustration of a termite.

Termites: Although there are more than 2000 species of termites across the world, only 50 or so of those species are found within the United States. Termites live in colonies; this means they live and work together to gather food and raise their young (larvae). Termites can pose a major threat to structures, which is why it is important to address any termite infestation as soon as possible. A qualified termite control company, or inspector should look for the many telltale signs termites usually provide such as small holes in wood, straw-shaped mud tubes, crumbling drywall, termite insect wings, and sagging doors or floors (Fig. 7.9).

Animal Allergens

Allergens are produced by many mammalian and avian species and can be inhaled by humans and cause immunological sensitization as well as symptoms of chronic allergic rhinitis and asthma. These allergens are normally associated with dander, hair, saliva, and urine of dogs, cats, rodents, and birds, although pollens, ragweed, and a variety of other allergens can find their way indoors from the outdoors. Ragweed is known to cause what is commonly referred to as “hay fever,” or what allergist/immunologists refer to as *allergic rhinitis*. In the United States, seasonal allergic rhinitis (hay fever), which is caused by breathing in allergens such as pollen, affects more than 35 million people.

7.2.2 General Steps to Reducing Pollutant Exposure

Pollutant source removal or modification is the best approach whenever sources are identified and control is possible. These may include:

- Routine maintenance of HVAC systems
- Applying smoking restrictions in the home and the office
- Venting contaminant source emissions to the outdoors

- Proper storage and use of paints, pesticides, and other pollutant sources in well-ventilated areas and their use during periods of nonoccupancy
- Allowing time for building materials in new or remodeled areas to off-gas pollutants before occupancy

Most mechanical ventilation systems in large buildings are designed and operated not only to heat and cool the air, but also to draw in and circulate outdoor air. One cost-effective method to reduce indoor pollutant levels is to increase ventilation rates and air distribution. At a minimum, HVAC systems should be designed, to meet ventilation standards in local building codes. In practice, however, many systems are not operated or adequately maintained to ensure that these design ventilation rates are in place. Often IAQ can be improved by operating the HVAC system to at least its design standard, and to ASHRAE Standard 62-2001 (there are numerous addenda to this standard; visit <https://www.ashrae.org/standards-research--technology/standards--guidelines>) if possible. When confronted with strong pollutant sources, local exhaust ventilation may be required to exhaust contaminated air directly from the building. The use of local exhaust ventilation is particularly advised to remove pollutants that accumulate in specific areas such as restrooms, copy rooms, and printing facilities. Air cleaners can also be a useful adjunct to source control and ventilation although they are somewhat limited in their application. Air cleaners are discussed in [Section 7.3.5](#) of this chapter.

Indoor air pollution is currently ranked among the top four environmental risks in America by the EPA, which may explain why for many forward-thinking real estate property managers it is becoming a standard of doing business to have their buildings routinely inspected as part of a Proactive IAQ Monitoring Program.

Investigating Indoor Air Quality

Indoor Air Quality (IAQ) investigations provide evaluations of air quality in both public and commercial buildings. Indoor air quality is defined by the depiction of concentrations of pollutants and thermal conditions that may negatively affect the health, comfort, and performance of a building's occupants. Thus, the procedure for investigating IAQ may be characterized as a cycle of information gathering, hypothesis formation, and hypothesis testing. It typically begins with a walkthrough inspection of the problem area to gather information relating to the four basic factors that influence indoor air quality namely:

- A building's occupants
- A building's HVAC system

- Possible pollutant pathways
- Possible sources of contamination

7.2.3 Thermal Comfort

Defining thermal comfort is somewhat elusive other than it is a state of well-being and involves temperature, humidity, and air movement among other things. Wikipedia says, “Thermal comfort is the condition of mind that expresses satisfaction with the thermal environment and is assessed by subjective evaluation (ANSI/ASHRAE Standard 55).” Often heard complaints facility managers get from building occupants is that their office space is either too cold or too hot. Studies show that people of different cultures generally have different comfort zones; even people belonging to the same family may feel comfortable under different conditions, and keeping everyone comfortable at the same time is not an easy matter. Regarding levels of thermal satisfaction, the Center for the Built Environment states “Current comfort standards specify a ‘comfort zone,’ representing the optimal range and combinations of thermal factors (air temperature, radiant temperature, air velocity, humidity) and personal factors (clothing and activity level) with which at least 80% of the building occupants are expected to express satisfaction.” This is the goal outlined by the ASHRAE in the industry’s gold standard of comfort—*Standard 55, Thermal Environmental Conditions for Human Occupancy*. ASHRAE Standard 55 also specifies what thermal conditions are deemed likely to be comfortable to occupants.

As previously mentioned, employee health and productivity are greatly influenced by the quality of the indoor environment. When temperature extremes—too cold or too hot—become the norm indoors, all building occupants suffer. In spaces that are either very hot or very cold, individuals must expend physiological energy to cope with the surroundings—energy that could be better utilized to focus on work and learning, particularly since research has shown that people simply don’t perform as well, and attendance declines, in very hot and very cold workplaces. Poor air quality and lighting levels, off-gassing of chemicals from building materials, and the growth of molds and bacteria can all adversely affect building occupants. Sustainable design supports the well-being of building occupants and their desire to achieve optimum comfort by reducing indoor air pollution. This can be achieved by applying a number of strategies such as the selection of materials with low off-gassing potential, providing access to daylight and views, appropriate ventilation strategies, and controlling lighting, humidity, and temperature levels.

Below are a number of relevant standards, codes, and guidelines (check websites for latest updates):

- ASHRAE Standard 62-1999: Ventilation for Acceptable Air Quality
- ASHRAE 129-1997: Measuring Air-Change Effectiveness
- South Coast Rule #1168, South Coast Air Quality Management District
- Regulation 8, Rule 51, of the Bay Area Air Quality Management District
- Canadian Environmental Choice/Ecologo
- Best Sustainable Indoor Air Quality Practices in Commercial Buildings
- Guidelines for Reducing Occupant Exposure to VOCs from Office Building Construction Materials
- Carpet and Rug Institute Green Label Indoor Air Quality Test Program

7.2.4 Noise Pollution

Much research has been conducted on noise pollution which is considered to be a form of energy pollution in which distracting, irritating, or damaging sounds are freely audible. Noise and vibration from sources including HVAC systems, vacuums, pumps, and helicopters can often trigger severe symptoms, including seizures, in susceptible individuals. In the United States, regulation of noise pollution was stripped from the federal EPA and passed on to the individual states in the early 1980s. Although two noise-control bills passed by the EPA remain in effect, the EPA can no longer form relevant legislation. Needless to say, a noisy workplace is not conducive to getting work done. What is not so apparent is that constant noise can lead to voice disorders for paraprofessionals in the office where many employees spend time on the telephone, or routinely use their voices at work. And although good engineering design can mitigate noise pollution levels to some extent, it is frequently not to acceptable levels, particularly if a significant number of individual sources combine to create a cumulative impact. Nevertheless, humans, whether tenants or building occupants have a basic right to live in environments that are relatively free from the intrusion of noise pollution, even though this may not always be possible.

Defining Noise

Noise can be defined as a form and level of environmental sound that is generally considered likely to annoy. The City of Berkeley's Planning and Development Department on the other hand defines sound as pressure variations in air or water which can be perceived by human hearing and the objectionable nature of sound could be caused by its pitch or its loudness. In addition to the concepts of pitch and loudness, there are several methods

to measure noise. The most common is use of a unit of measurement called a decibel (dB). On the dB scale, the zero represents the lowest sound level that a healthy, unimpaired human ear can detect. Sound levels in dBs are calculated on a logarithmic basis. Thus, an increase of 10 dB represents a 10-fold increase in acoustic energy, and a 20 dB increase is 100 times more intense (10×10), etc. The human ear likewise responds logarithmically, and each 10-dB increase in sound level is perceived as approximately a doubling of loudness.

Impact of Noise

Sound is of great value; it warns us of potential danger and gives us the advantage of speech and the ability to express joy or sorrow. But sometimes sound can also be undesirable. For example, sound may interfere with and disrupt useful activities. Sometimes too, sounds such as certain types of music (e.g., pop or opera) may become noise at certain times (e.g., after midnight), in certain places (e.g., a museum), or to certain people (e.g., the elderly). There is therefore the introduction of a value judgment among people as to when sound becomes unwanted noise which is why it is difficult to offer a clear definition of “good” or “bad” noise levels in any attempt to generalize the potential impact of noise on people.

Health Effects

Wikipedia points out that elevated noise in the workplace or home can “cause hearing impairment, hypertension, ischemic heart disease, annoyance, sleep disturbance, and decreased school performance. Changes in the immune system and birth defects have been attributed to noise exposure, but evidence is limited.” Hearing Loss is potentially one of the disabilities that can occur from chronic exposure to excessive noise, but it may also occur in certain circumstances like after an explosion. Noise exposure has also been known to induce dilated pupils, elevated blood pressure, tinnitus, hypertension, vasoconstriction, and other cardiovascular impacts.

The Occupational Safety and Health Administration (OSHA) has a noise exposure standard which is set at just below the noise threshold where hearing loss may occur from long-term exposure. The impact of noise on physical stress reactions can be readily observed when people are exposed to noise levels of 85 dB or higher. The safe maximum level is set at 90 dB averaged over 8 h. If the noise is above 90 dB, the safe exposure dose becomes correspondingly shorter. Adverse stress-type reaction

to excessive noise can be broken down into two stages. The first stage is where noise is above 65 dB making it difficult to have a normal conversation without raising one's voice. The second is the link between noise and socioeconomic conditions that may further lead to undesirable stress-related behavior, increase workplace accident rates or in many cases, stimulate aggression and other antisocial behaviors when they are exposed to chronically excessive noise.

Major Sources of Noise

The prevailing sources of artificial noise pollution in today's urban communities that are outside the control of affected individuals include:

- Transportation: cars, trucks, buses, trains near railroad tracks, and aircraft near airports
- Routine activities of daily life
- Construction activity
- Industrial-plant equipment noise

Cities in the United States currently can only adopt noise exposure standards for noise levels emanating from trucks, trains, or planes and then not permit land uses to be developed in areas with excessive noise for an intended use. Cities also play a role in enforcing state vehicle code requirements regarding muffler operation and may set speed limits or weight restrictions on streets that impact noise generation. However, a city's actions are typically proactive with regard to nontransportation sources and reactive for sources outside the city's control. Noise Abatement and reduction of excessive noise exposure can be accomplished by reducing the noise level at the source, increasing the distance between the source and the receiver, and place an appropriate obstruction (e.g., a wall) between the noise source and the receiver.

A noise wall may sometimes be the only practical solution since vehicular noise is exempt from local control and relocation of sensitive land uses away from freeways or major roads is not practical. Yet with noise walls we have both a positive side, the ability to reduce the noise exposure to affected persons, and a negative side, that is effectively blocking the line of sight between source and receiver. A properly sited wall can reduce noise levels by almost 10 dB which for most people translates to being about one-half as loud as before. Unfortunately, the social, economic, and aesthetic costs of noise walls are high. While noise walls would screen the traffic from receivers, it may also block beautiful views of trees, parks, and water, and may also give drivers a claustrophobia feeling of being surrounded by massive walls.

7.2.5 Daylighting and the Daylight Factor

The sun has been our principal source of light and heat for millions of years, and we have become almost totally dependent on it for our health and survival. The world and, in particular, the sustainable design movement is now returning to nature because of its increasing concern with global warming, carbon emissions, and sustainable design, and has started to take positive steps to increase its use of managed admission of natural light in both residential and nonresidential buildings. Daylighting has come to play a pivotal role in programs such as LEED, the new IgCC and now has increased recognition in California's Title 24 energy code. According to Craig DiLouie of the Lighting Controls Association daylighting is defined as "the use of daylight as a primary source of illumination to support human activity in a space." Direct sunlight is a most powerful source and has the greatest impact on our lives; it not only provides visible light, but also provides ultraviolet and infrared (heat) radiation (Fig. 7.10).

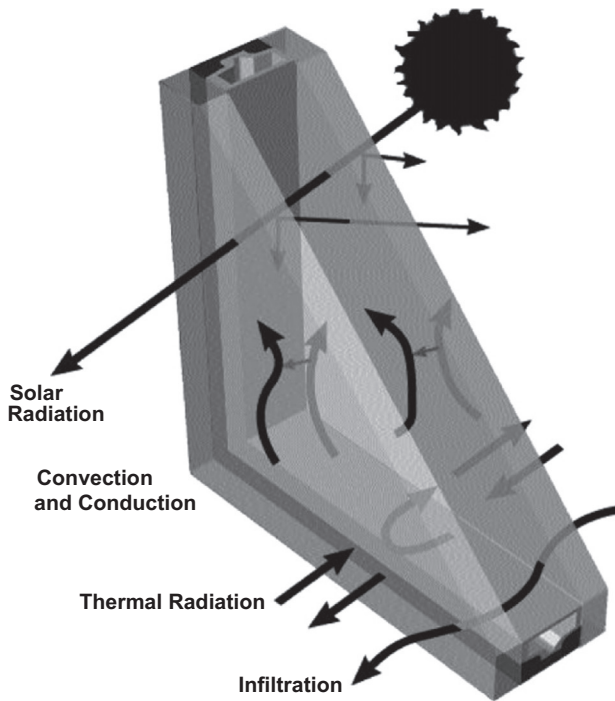

Figure 7.10 The three major types of energy flows that occur through windows: (1) Nonsolar heat losses and gains in the form of conduction, convection, and radiation (2) solar heat gains in the form of radiation and (3) airflow, both intentional as ventilation and unintentional as infiltration. *Source: US DOE.*

Assessing the daylight quality in a room traditionally consisted of a manual average daylight factor (DF) calculation, or based on a computerized version of the manual method. The term “average DF” is sometimes construed to be the average DF on all surfaces, whereas the output from most computer-based calculations reflect average DF calculations derived from a series of points on the working plane. But in light of recent technological advances, daylight design is rapidly moving forward and is now able to provide the kind of information that would accommodate all of the requirements of the daylight consultant, the architect, and the end user. The ideal package should integrate natural lighting and electrical lighting calculations and also take into account an evaluation of the thermal impact on window design. [Table 7.5](#) lists recommended illumination levels for various locations and functions.

Daylight availability in a room is normally expressed by a measure commonly called the DF. Chris Croly, a building services engineering associate with BDP Dublin and Martin Lupton, a director with BDP Lighting, however, state that, “The calculation of daylight factor using traditional methods becomes particularly difficult when trying to assess the effects of transfer glazing, external overhangs, or light shelves. Modern radiosity or ray tracing calculations are now readily available and are easy to use but still generally offer results in the form of daylight factor or lux levels corresponding to a particular static external condition.” They define DF as, “the ratio of the internal illuminance to that on a horizontal external surface located in an area with an unobstructed view of a hemisphere of the sky.” The DF thus describes the ratio of outside luminance over inside luminance, expressed

Table 7.5 Table showing recommended illumination levels

Area	Foot-candles
Building surrounds	1
Parking area	5
Exterior entrance	5
Exterior shipping area	20
Exterior loading platforms	20
Office corridors and stairways	20
Elevators and escalators	20
Reception rooms	30
Reading or writing areas	70
General office work areas	100
Accounting/bookkeeping areas	150
Detailed drafting areas	200

in percent. The higher the DF, the more natural light that is available in the room. The impact of direct sunlight to both illuminances must be considered separately and is not included. The DF can be expressed as:

$DF = 100 \cdot E_{in} / E_{ext}$, where E_{in} represents the inside illuminance at a fixed point and E_{ext} represents the outside horizontal illuminance under an overcast (Commission Internationale de l'Eclairage (CIE) sky) or uniform sky, as defined by the CIE.

Daylighting Strategies

Research over the years clearly demonstrates that effective daylighting saves energy and improves the quality of the visual environment, while reducing operating costs and enhancing occupant satisfaction. Thus, while daylight can reduce the amount of electric light needed to adequately illuminate a workspace and therefore reduce potential energy costs, allowing too much light or solar radiation into a space can have a negative effect, resulting in heat gain, offsetting any savings achieved by reduced lighting loads. Some architectural/design firms known for their sustainable design inclinations like HOK and Gensler design the majority of their buildings to be internally load-dominated, meaning the buildings need to be cooled for most of the year. Strategies for improved daylighting include use of miniature optical light shelves, light-directing louvers, light-directing glazing, clerestories, roof monitors and skylights, light tubes and heliostats. It is important to appreciate that whatever tools are applied in the daylighting design process, to be successful will involve the integration of several key disciplines including architectural, mechanical, electrical, and lighting. As with sustainable design in general, an integrated design approach is needed where team members are brought into the design process early to ensure that daylighting concepts and strategies are satisfactorily implemented throughout the project (Fig. 7.11).

The application of innovative and advanced daylighting strategies and systems can significantly enhance the quality of light in an indoor environment as well as improve energy efficiency by minimizing lighting, heating, and cooling loads thereby reducing a building's electricity consumption. By providing a direct link to the outdoors, daylighting helps create a visually stimulating and productive environment for building occupants, at the same time significantly reducing the total building energy costs.

Note that when light hits a surface, part of the light is reflected back. This reflection normally takes the form of diffused (nondirectional) and is dependent on the object's reflection. The reflection of the outside ground

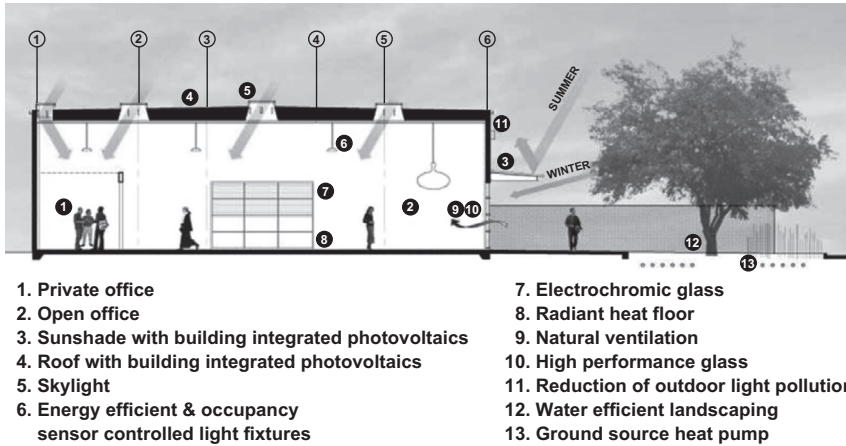

Figure 7.11 Schematic drawing illustrating an integrated approach to the design of a building's various systems in the new IDEAs headquarters. *Courtesy: Integrated Design Associates, Inc.*

is typically in the order of 0.2% or 20%. This means that in addition to the direct sunlight and skylight components, there also exists an indirect component which can make a significant contribution to the lighting inside a building, especially since the light reflected off the ground will hit the ceiling thus adding to its brightness.

Daylighting and Visual Comfort

Designing for natural light has for many years been a challenge that designers often face, due to the fluctuations in light levels, colors, and direction of the light source. This led architects and engineers to make some unwise design decisions which in the 60s and 70s culminated in hermetically sealed office blocks that were fully air conditioned and artificially lit. This in turn led to a sharp increase in complaints and symptoms attributed to BRIs and SBS. Gregg Ander, FAIA says that "In large measure, the art and science of proper daylighting design is not so much how to provide enough daylight to an occupied space, but how to do so without any undesirable side effects." Designers should adopt practical design strategies for sustainable daylighting design that will increase visual comfort by applying three primary techniques. These are basic lighting approaches that reflect the strategies of sustainability and thus support the larger ecological goal. These strategies are:

- Architectonic: What has made daylighting design so difficult until recently is the lack of specific design tools. Today most large architectural

practices have a diverse team of consultants and design tools that enable them to undertake complex daylighting analysis, whereas the typical school, or small office do not have this capability or the budget for it.

- Environmental: using the natural forces that impact design, resource, and energy conservation.
- Human Factors: the impact on people and their experience. Designers need to achieve the best lighting levels possible while avoiding glare and high-contrast ratios. These can usually be avoided by not allowing direct sunlight to enter a workspace, e.g., through the use of shading devices.

A study conducted by the Heschong Mahone Group (HMG), a California architectural consulting firm, concluded that students who received their lessons in classrooms with more natural light scored as much as 25% higher on standardized tests than students in the same school district but whose classrooms had less natural light. This appears to confirm what many educationalists have suspected, i.e., that children's capacity to learn is greater under natural illumination from skylights or windows than from artificial lighting. The logical explanation given is that "daylighting" enhances learning by boosting the eyesight, mood, and/or health of students and their teachers.

Another investigation by HMG looked at the relationship of natural light to retail sales. The study analyzed the sales of 108 stores that were part of a large retail chain. The stores were all one storey and virtually identical in layout, except that two-thirds of the stores had skylights while the others did not. The study specifically focused on skylighting as a means to isolate daylight as an illumination source, and avoid all of the other qualities associated with daylighting from windows. When they compared the sales figures for the various stores they discovered a statistically compelling connection between skylighting and retail sales performance, and found that stores with skylight systems had increased sales by 40%—even though the design and operation of all the store sites was remarkably uniform, except for the presence of skylights in some of the stores. The study showed that all other things being equal, an average nonskylit store in the chain would likely increase their sales by an average of about 40% just by adding skylights, even though the design and operation of all the store sites was remarkably uniform, except for the presence of skylights.

Technology is moving at such a rapid pace and architects are now increasingly specifying high-performance glass with spectrally selective coatings that only allows visible light to pass through the glass while keeping out the infrared wavelength. This eliminates most of the infrared and ultraviolet radiation while allowing the majority of the visible light spectrum through

the glass. But even with high-performance glass, much of the light can be converted to heat. Glass with high visible light transmittance still allows light energy into a building, and when this light energy then hits a solid surface, it is absorbed and reradiated into the space as heat.

Combining daylighting with efficient electric lighting strategies can provide substantial energy savings. The building's planning module can often give indications on how best to organize the lighting. In any case, the lighting system must correlate to the various systems in place including structural, curtain wall system, ceiling system, and furniture system. Likewise, initial lighting costs may rise when designing for sustainability and implementing energy-efficient strategies. These energy-saving designs may require items like dimmable ballasts, photocells, and occupancy sensors, all of which are not typically covered in most traditional project budgets (Fig. 7.12). However, these items would normally be included if an integrated design approach was employed and where daylight strategies were appropriately employed at an early phase of the project's design.

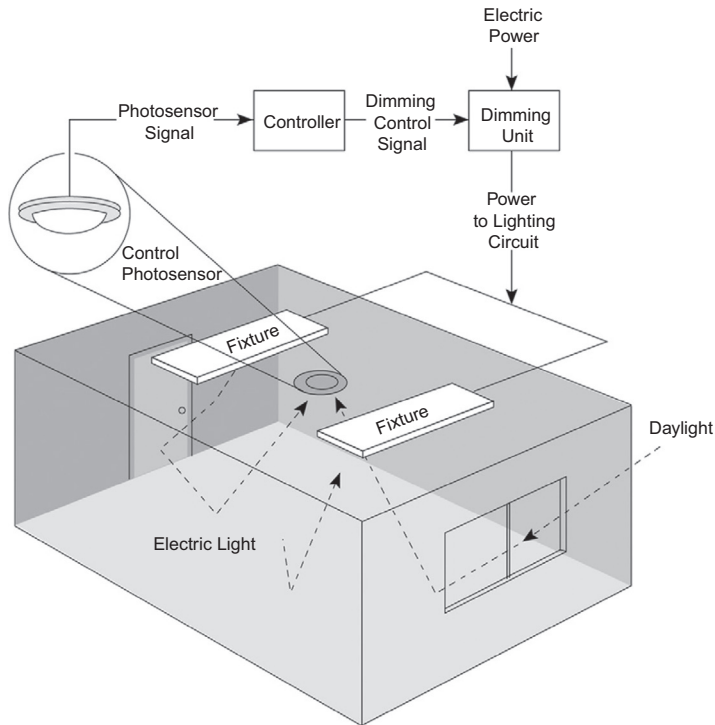

Figure 7.12 Schematic diagram of a room utilizing a photoelectric dimming system. The ceiling-mounted photosensor reads both electric light and daylight within the space and adjusts the electric lighting as required to maintain the design level of total lighting. Source: Ernest Orlando Lawrence Berkeley National Laboratory.

Daylight has many positive attributes, the main one being enhancing the psychological value of space. Likewise, the introduction of daylight into a building reduces the need for electric lighting during the day while helping to link indoor spaces with the outdoors for the building occupants. However, natural light also has its negatives such as glare, overheating, variability, and privacy issues. It is left to the designer therefore to find ways to increase the positive aspects of using natural light in buildings, while at the same time reducing the negative. Addressing glare requires keeping sunlight out of the field of view of building occupants while protecting them from disturbing reflections. Addressing overheating means adding appropriate exterior shading, filtering incoming solar radiation or even using passive control means such as thermal mass. Furthermore, addressing the variability and privacy issues requires creative ways to block or alter light patterns and compensate with alternative sources of light.

In recent years, the implementation of daylighting strategies at an early stage of a building design has become vital for the success of the building's lighting strategy. This is because previously simple tools that can predict the performance of advanced daylighting strategies were not available to the designer. The data output from their daylighting studies could be extremely useful for fine-tuning and finalizing the building's orientation, massing, space planning, and interior finishes. Innovative daylighting systems are designed to redirect sunlight or skylight to areas where it is most needed, yet avoiding glare.

The financial and competitive pressures of powerful market forces are driving some owners and design teams to seek architectural solutions such as the utilization of highly glazed, transparent façades. While these trends may offer clear potential benefits, such approaches also expose owners to real risks and costs associated with them as well. The general interest in potential benefits from these design solutions can be summarized as follows:

- Most building owners desire daylight and find concepts and buildings that employ highly transparent façades preferable to the dark-tinted or reflective buildings of the 1970s and 1980s.
- Building owners are generally aware of the potential health and productivity benefits of daylight.
- The evident shift toward highly glazed façades is coupled with interior designs that reflect the desire of building owners to provide views and daylight to their employees. Open plans and, low-height partition furniture layouts, allow the daylight zones to be extended from a conventional 10–15 ft (3.0 to 4.6 m) depth to a 20 ft (6.1 m) or even 30 ft (9.1 m) depth from the window wall.

- The increased use of low-reflectance, higher brightness flat-screen LCD monitors, has allowed architects to employ design solutions that involve increasing daylight and luminance levels within buildings. But to take full advantage of natural daylight and avoid potential dark zones, it is critical that the lighting designer plans the lighting circuits and switching schemes in relation to the building's fenestration system.

These systems use optical devices that initiate reflection, refraction, and/or use the total internal reflection of sunlight and skylight. And with today's advancing technology daylighting systems can be programmed to actively track the sun's movement or passively control the direction of sunlight, skylight, and other shading systems (Fig. 7.13). Some owners are being driven by the financial and competitive pressure of powerful market forces to seek architectural solutions such as the utilization of highly glazed, transparent façades. While these trends may offer clear potential benefits, such approaches also expose owners to real risks and costs associated with their use. The following are significant potential risks associated with highly glazed façades:

- Increased sun penetration and excessive brightness levels that exceed good practice may cause or heighten visual discomfort.
- Adequate tools may not always be available to reliably predict thermal and optical performance of components and systems, and to assess environmental quality.

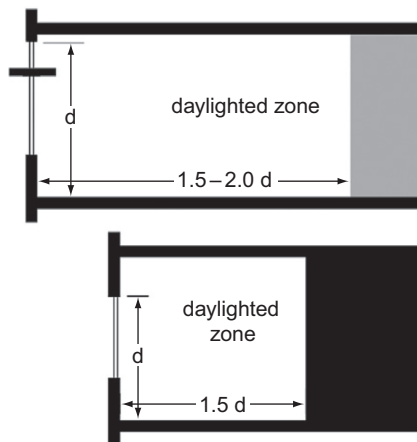

Figure 7.13 A rule of thumb for daylight penetration with typical depth and ceiling height is 1.5 times head height for standard windows, 1.5 to 2.0 times head height with light shelf, for south facing windows under direct sunlight. *Source: Ernest Orlando Lawrence Berkeley Laboratory.*

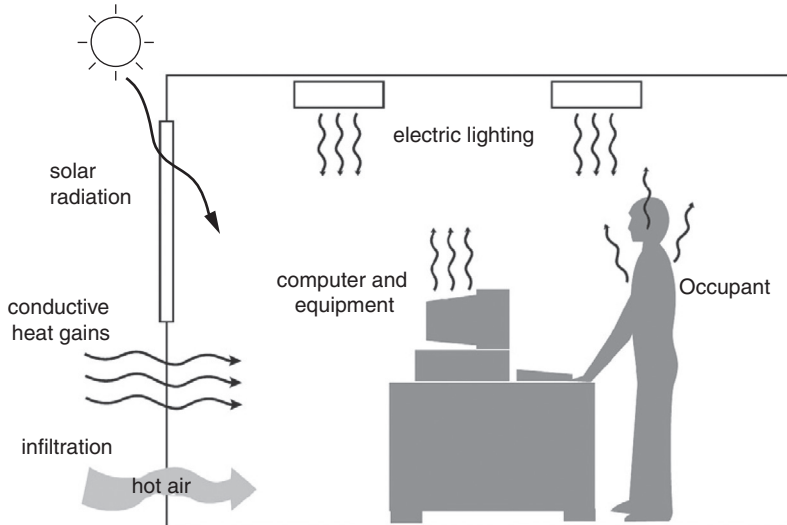

Figure 7.14 Graphic of various cooling load sources. *Source: Ernest Orlando Lawrence Berkeley Laboratory.*

- Buildings utilizing transparent glazing generally use greater cooling loads and cooling energy, which has the potential for thermal discomfort (Fig. 7.14).
- Increased cost of automated shading systems and purchasing lighting controls utilizing dimming ballasts and difficulty in commissioning systems after installation.
- Technical difficulty and high cost of reliably integrating dimmable lighting and shading controls with each other and with building automation systems to ensure effective operation over time.
- Uncertainty of occupant behavior with the use of automated, distributed controls in open landscaped office space and the potential for conflict between different needs and preferences.

Large glazed spaces in work areas (as distinct from corridors, lobbies, etc.) require much better sun and glare control to reap potential benefits and minimize possible risks. Appropriate solutions must be delivered by systems that can rapidly respond to exterior climate and interior needs. One of the challenges facing manufacturers is how to provide such needed increased functionality at lower cost and lower risk to owners. Due to various advantages and disadvantages, lighting consultants often recommend the use of switching for spaces with nonstationary tasks such as corridors, and continuous dimming for spaces where users perform stationary tasks,

such as offices. It has been shown that daylight harvesting using continuous dimming equipment automatically controlled by a photosensor, can generate 30–40% savings in lighting energy consumption, thereby significantly reducing operating costs.

Shades and Shade Controls

The greatest benefit of harvesting daylight can be achieved implementing a shading strategy that is tailored to the building in question. In hot climates, exterior shading devices have been found to work well to both reduce heat gain and diffuse natural light prior to entering the workspace (Fig. 7.15). Examples of such devices include light shelves, overhangs, vertical louvers, horizontal louvers, and dynamic tracking or reflecting systems. Thus, for example, exterior shading of the glass can eliminate up to 80% of the solar heat gain. Shades and shade control strategy is based on the perception that occupants of commercial buildings typically prefer natural light to electric light, and the shade system goals would normally include maximizing use of natural light within a glare free environment, while avoiding direct solar radiation on occupants through interception of sunlight penetration. Such a strategy may also include facilitating occupant connectivity with the outdoors through increased glazing and external views.

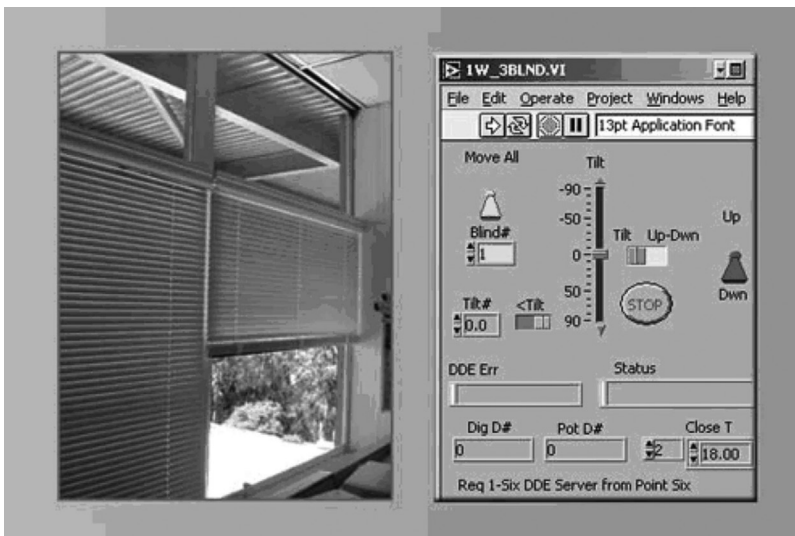

Figure 7.15 A venetian-blind system at a Berkeley Lab office building is equipped with a “virtual instrument” panel for IBECS control of blinds settings. *Courtesy: HPCBS.*

7.2.6 Views

Research over the years has shown that windows providing daylight and ample views can dramatically affect building occupants' mental alertness, productivity, and psychological well-being. David Hobstetter, principal in Kaplan-McLaughlin-Diaz, a San Francisco-based architectural practice reaffirms this saying, "Dozens of research studies have confirmed the benefits of natural daylight and views of greenspace in improving a person's productivity, reducing absenteeism and improving health and well-being." Though some educators opine that views out of windows may be unnecessarily distracting to students, the CEC's 2003 study of the Fresno school district found that a varied view out of a window, that included vegetation or human activity and objects in the far distance, supported better learning.

Such findings confirm results of earlier research, such as a 1984 hospital study that concluded that postoperative patients with a view of vegetation took far fewer painkillers and experienced faster recovery times than patients looking at plain concrete walls. Another revealing study noted that computer programmers with views spent 15% more time on their primary task, while workers without views spent 15% more time talking on the phone or to one another.

Building occupants generally relish contact with the outside world, even if only through a windowpane, and landscapes not surprisingly are preferred to cityscapes, and in many countries around the world, views, whether high-rise or otherwise, are normally considered mere perks. Moreover, some researchers contend that the view from a window may be even more important than the daylight it admits. The California Energy Commission's 2003 study of workers in the Sacramento Municipal Utility District's call center found that better views were consistently associated with better performance: "Workers with good views were found to process calls 7% to 12% faster than colleagues without views. Workers with better views also reported better health conditions and feelings of well-being, while their counterparts reported higher fatigue."

Researchers have also concluded that views of nature improve attention spans after extended mental activity has drained a person's ability to concentrate. Among the main building types that can most benefit from the application of daylighting are educational buildings such as schools, administrative buildings such as offices, maintenance facilities, and storage facilities such as warehouses.

7.3 VENTILATION AND FILTRATION

In ancient times, buildings whether a Babylonian palace, an Egyptian temple or a Roman castle, were ventilated naturally using either “badgeer/malqafs” (wind shafts/towers) or some other innovative method (Fig. 7.16) since mechanical systems did not exist at the time. Andy Walker of the National Renewable Energy Laboratory says, “Wind towers, often topped

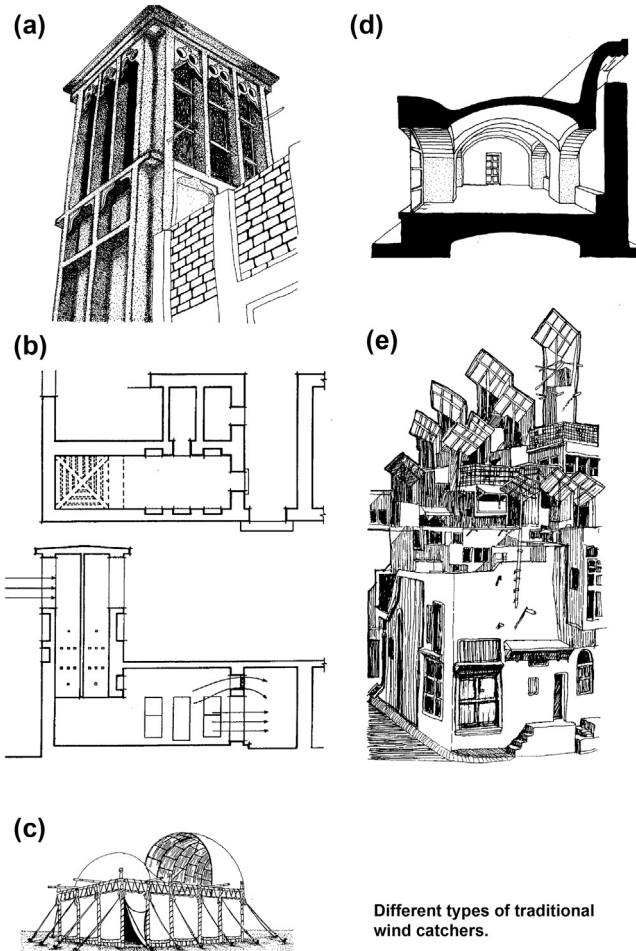

Figure 7.16 Drawings depicting various types of wind catchers (“badgeer”/“malqaf”) used in traditional and ancient architecture. (a) Multidirectional traditional Dubai wind catcher. (b) Plan and section of Dubai wind catcher. (c) Ancient Assyrian wind catcher. (d) Section through traditional wind scoop. (e) Traditional Pakistani wind catchers.

with fabric sails that direct wind into the building, are a common feature in historic Arabic architecture, and are known as ‘malqafs.’ The incoming air is often routed past a fountain to achieve evaporative cooling as well as ventilation. At night, the process is reversed and the wind tower acts as a chimney to vent room air.”

It is not surprising that with today’s increased awareness of the cost and environmental impacts of energy use, natural ventilation has once again come to the fore and become an increasingly attractive method for reducing energy use and cost and for providing acceptable IEQ. Natural ventilation systems utilize the natural forces of wind and buoyancy, i.e., pressure differences to move fresh air through buildings. These pressure differences can be a result of wind, temperature differences, or differences in humidity. The amount and type of ventilation achieved will depend to a large extent on the size and placement of openings in the building. In today’s polluted environment, inadequate ventilation is one of the main culprits that cause increased indoor pollutant levels by not bringing in enough outdoor air to dilute emissions from indoor sources and by not removing these indoor air pollutants to the exterior.

7.3.1 Ventilation and Ductwork

Appropriate ventilation is vital for the health and comfort of building occupants. It is specifically needed to reduce and remove pollutants emitted from various internal and external sources. Good design combined with optimum airtightness is a prerequisite to ensuring healthy air quality, occupant comfort, and energy efficiency. Sufficient air supply and movement can be tested and analyzed to determine efficiency of an HVAC system. Regular maintenance of ductwork is pivotal to achieving both better indoor environment and system stability. Ductwork can be evaluated, cleaned, and sealed to prevent airflow and potential quality issues. All ductwork should be analyzed by a professional trained and certified by the National Air Duct Cleaning Association.

7.3.2 Air Filtration

It is surprising that to date, we lack Federal standards for air filter performance. Air cleaning filters are designed to remove pollutants from indoor air, to improve the indoor environment and breathe cleaner air. Proper filtration removes dirt, dust, and debris from the air you breathe and reduces pollen and other allergens, which can cause asthmatic attacks and allergic reactions. Filters awarded the *High-Efficiency Particulate Air* accolade has to satisfy certain standards of efficiency such as those set by the United States

Department of Energy (DOE). To qualify as HEPA by government standards, an air filter must remove 99.97% of all particles greater than 0.3 μm from the air that passes through. A filter that is qualified as HEPA is superior to those unqualified, but is also subject to interior classifications. And although air cleaning devices may help to control the levels of airborne allergens, particles, and in some cases, gaseous pollutants in a facility, they may not decrease adverse health effects from indoor air pollutants.

The marketplace is currently flooded with various types of air filters including mechanical filters, electronic filters, hybrid filters, gas phase, and ozone generators—some of which are designed to be installed inside the ductwork of a facility's central heating, ventilating, and air-conditioning (HVAC) system to clean the air in the whole facility. Other types include portable room air cleaners which are designed to be used to clean the air in a single room or specific areas, and are not intended for complete facility filtration. Filters are often rated according to the Minimum Efficiency Reporting Value (MERV), which is a filter rating system devised by the ASHRAE to standardize and simplify filter efficiency ratings for the public. In the MERV rating system, the higher the rating, the higher the efficiency of the air filter; thus a MERV 12 filter will remove smaller particles from the air than a MERV 8 filter. Before making a determination on the most appropriate filter for a project or home, adequate research is required (see ANSI/AHRI Standard 680 (I-P)-2009).

7.3.3 Air Purification

Pollutants are released more or less continuously from many sources, such as building materials, furnishings, and household products like air fresheners. Some sources, related to activities carried out in the home or workplace, release pollutants intermittently. These include smoking, the use of unvented or malfunctioning stoves, furnaces, or space heaters, the use of solvents in cleaning and hobby activities, the use of paint strippers in redecorating activities, and the use of cleaning products and pesticides. High pollutant concentrations can remain in the air for extended periods after some of these activities cease if appropriate action is not taken. While air filtration removes particulate, air purification is required to remove the things a filter fails to, such as odors and gases. Chemicals in paints, carpets, and other building materials (i.e., VOCs) are harmful to building occupants and should be removed through air purification. There is also an increasing concern regarding the presence of biological infectious agents, and one

way to address these potential problems is through air purification on a regular basis. These concerns have encouraged the use of air purifiers that are intended to relieve allergy symptoms, fight pollution, eradicate airborne pollutants, remove unwanted smells, and eliminate germs.

7.3.4 Amount of Ventilation

There are various means for outdoor air to enter and leave a building particularly infiltration, natural ventilation, and mechanical ventilation. Outdoor air can infiltrate a building through openings, joints, and cracks in walls, floors, and ceilings, and around windows and doors. Natural ventilation involves air moving through opened windows and doors. Air movement associated with infiltration and natural ventilation is a consequence of air temperature differences between the indoor and outdoor air and by wind. When insufficient outdoor air enters a home, pollutants can accumulate to elevated levels to a degree that they can pose health and comfort problems. In the event that natural ventilation is insufficient to achieve good air quality, there are a number of mechanical ventilation devices, from outdoor-vented fans that will intermittently remove air from a room, such as bathrooms and kitchen, to air handling systems that utilize fans and duct systems to continuously remove indoor air and distribute filtered and conditioned outdoor air to strategic points throughout the building. The rate at which outdoor air replaces indoor air is known as the *air exchange rate*. Insufficient air infiltration, natural ventilation, or mechanical ventilation means that the air exchange rate is low and rising pollutant levels should be expected.

Residents or occupants are occasionally in a position to take appropriate action to improve the indoor air quality of a space by removing the source, altering an activity, unblocking an air supply vent, or opening a window to temporarily increase the ventilation; in other cases, however, the building owner or manager is the only one in a position to remedy the problem. Building management should be prevailed upon to follow guidance in EPA's IAQ Building Education and Assessment Model (I-BEAM). I-BEAM expands and updates EPA's existing Building Air Quality guidance and is considered to be a complete state-of-the-art program for managing IAQ in commercial buildings. Building management should also be encouraged to follow guidance in EPA and NIOSH's Building Air Quality: A Guide for Building Owners and Facility Managers. The BAQ guidance is available in a downloadable PDF format.

7.3.5 Ventilation Improvements

Increasing the amount of outdoor air coming indoors is another approach to lowering the concentrations of indoor air pollutants. Many heating and cooling systems, including forced air heating systems, do not mechanically bring fresh air into the house. This can often be addressed by opening windows and doors, or running a window air conditioner with the vent control open increases the outdoor ventilation rate. In residents, local bathroom or kitchen fans that exhaust outdoors can be used to remove contaminants directly from the room where the fan is located while increasing the outdoor air ventilation rate. Good ventilation is especially important when undertaking short-term activities that can generate high levels of pollutants like painting, paint stripping, or heating with kerosene heaters. Such activities should preferably be executed outdoors whenever possible. The following design recommendations can help achieve better ventilation in buildings:

- Naturally ventilated buildings should preferably be narrow, as it is difficult to distribute fresh air to all areas of a wide building using natural ventilation. The maximum width that one may expect to ventilate naturally is estimated at 45 ft. Consequently, buildings that rely on natural ventilation typically have an articulated floor plan. Use of mechanical cooling is recommended in hot, humid climates.
- Occupants should be able to operate window openings.
- The use of fan-assisted cooling strategies should be considered. Employing ceiling and whole-building fans can provide up to 9°F effective temperature drop costing about one-tenth the electrical energy consumption of mechanical air-conditioning systems.
- Decide whether an open- or closed-building ventilation approach potentially offers the best results (A closed-building approach is more appropriate in hot, dry climates where there is a large diurnal temperature range from day to night. An open-building approach is more effective in warm and humid areas, where the temperature difference between day and night is relatively small).
- Maximize wind-induced ventilation by siting the ridge of a building perpendicular to the summer winds. Also, buildings should be sited where summer wind obstructions are minimal. A windbreak of evergreen trees may also be useful to mitigate cold winter winds that tend to come predominantly from the north.
- When possible, provide ventilation to the attic space as this greatly reduces heat transfer to conditioned rooms below. In buildings with

attics, ventilating the attic space greatly reduces heat transfer to conditioned rooms below. Ventilated attics have been found to be approximately 30°F cooler than unventilated attics.

Air Cleaners

Air cleaners come in a variety of types and sizes ranging from relatively inexpensive tabletop models to larger more sophisticated and expensive systems. Some air cleaners are highly effective at particle removal, while others, including most tabletop models, are much less so. It should be noted that air cleaners are generally not designed to remove gaseous pollutants. The effectiveness of an air cleaner is expressed as a percentage efficiency rate. It depends on how well it collects pollutants from indoor air and how much air it draws through the cleaning or filtering element. The latter is expressed in cubic feet per minute. The fact needs noting that even an efficient collector that has a low air-circulation rate will not be effective; neither will an air cleaner with a high air-circulation rate but a less efficient collector. All being said, the long-term performance of any air cleaner depends to a large extent on maintaining it in accordance with manufacturer's directions.

Another critical factor in determining the effectiveness of an air cleaner is the level and strength of the pollutant source. Tabletop air cleaners, in particular, may not be capable of adequately reduce amounts of pollutants from strong nearby sources. Persons who are sensitive to particular pollutant types may find that air cleaners are useful mostly when used in conjunction with collaborative efforts to remove the source of pollution.

Ventilation Systems

Most large commercial buildings have mechanical ventilation systems that are typically designed and operated to heat and cool the air, as well as to draw in and circulate outdoor air. However, ventilation systems themselves can be a source of indoor pollution and contribute to indoor air problems if they are poorly designed, operated, or maintained. They can sometimes spread harmful biological contaminants that have steadily multiplied in cooling towers, humidifiers, dehumidifiers, air conditioners, or inside surfaces of ventilation ducts. For example, problems arise when, in an effort to save energy, ventilation systems are incorrectly programmed and bring in adequate amounts of outdoor air. Other examples of inadequate ventilation occur when the air supply and return vents within a space are blocked or placed in a manner that prevents the outdoor air to reach the breathing zone of building occupants. Improper location of outdoor air intake vents

can also bring in contaminated air, particularly from automobile and truck exhaust, fumes from dumpsters, boiler emissions, or air vented from kitchens and bathrooms.

For naturally ventilated spaces, refer to California High Performance Schools (CHPS) Best Practices Manual Appendix C, “A Field Based Thermal Comfort Standard for Naturally Ventilated Buildings.” For Mechanically Ventilated Spaces designers should refer to ASHRAE Standard 55-1992, Addenda 1995 “Thermal Environmental Conditions for Human Occupancy.”

RELEVANT CODES AND STANDARDS.

- Energy Policy Act of 2005 (PDF 1.9MB, 550 pages)
- Naturally ventilated buildings should be designed to provide thermal comfort, to achieve adequate moisture and contaminant removal, and to meet or exceed Government Energy Conservation Performance Standards.
- Standards for building thermal comfort have been defined by ASHRAE 55.
- Standards for adequate ventilation rates and contaminant levels are found in ASHRAE 62
- Additional standards effecting ventilation practice have been developed by:
- American Conference of Governmental Industrial Hygienists (ACGIH)
- ACGIH: provides threshold limit values for chemical substances and physical agents and biological exposure indices.
- OSHA
- OSHA (1989), Air Contaminants: examines Air Contaminants-Permissible Exposure limits (Title 29, Code of Federal Regulations, Part 1910.1000).
- Federal energy standards: The US DOE has updated 10 CFR 435 to reflect the codified version of the ASHRAE/Illuminating Engineering Society of North America Standard 90.1 to be closer to the existing voluntary sector code. This new federal standard, 10 CFR 434 Energy Code for New Federal Commercial and Multi-Family High Rise Residential Buildings, is mandatory for all new federal buildings. For existing buildings, refer to ASHRAE 100 Energy Conservation in Existing Buildings. For residential buildings, the applicable standard is ASHRAE 90.2 Energy Efficient Design of Low-Rise Residential Buildings. Methodology and Procedures for Life-Cycle Cost Analysis are described in 10 CFR 436.



7.4 BUILDING MATERIALS AND FINISHES—EMITTANCE LEVELS

Although several studies have been conducted over the years to investigate the impact of pollution emitted by building materials on the indoor air quality and then relating the results to ventilation requirements, there has been a lack of systematic experiments, in which building materials are initially ranked according to their pollution strength, and then analyzing the impact on the indoor air quality when using these materials in real rooms. Such studies would allow us to quantify the extent to which using low polluting building materials would reduce the energy used for ventilation of buildings without having to compromise indoor air quality. One of the primary objectives of an ongoing research project is to quantify this energy-saving potential based on the effects on the perceived air quality.

7.4.1 Toxic Building Materials

The Healthy Building Network (HBN) identifies the primary building materials that are considered toxic and which have unacceptable high VOC emittance levels. Examples are given in the following subsections.

Polyvinyl Chloride

Polyvinyl chloride (PVC) and its by-products contain known carcinogens that are released as they age and release dioxin when burned. This is why HBN singled it out for elimination. Likewise because of its uniquely wide and potent range of chemical emissions throughout its life cycle including many of the target chemicals listed below. It is virtually the only material that requires phthalate plasticizers, frequently includes heavy metals and emits large amounts of VOCs. In addition, during manufacture, it produces a large quantity of highly toxic chemicals including potent carcinogen dioxins, vinyl chloride, ethylene dichloride, PCBs, and others. Moreover, when burned, it releases hydrochloric acid and more dioxins. It is therefore prudent to avoid products made with PVC.

Volatile Organic Compounds

As discussed earlier, VOCs consist of thousands of different chemicals, such as formaldehyde and benzene, which evaporate readily into the air. Depending on the level of exposure, they can cause dizziness, headaches, eye, nose, and throat irritation or asthma, and in some cases, can also cause

cancer, induce longer term damage to the liver, kidney, and nervous system, and stimulate higher sensitivity to other chemicals. When dealing with wet products such as paints, adhesives, and other coatings, ensure that the products contain no or low VOC in them. Look for the *Green Seal* when using certified paints or paints with less than 20 g/L VOCs. For adhesives and coatings, make sure they are South Coast Air Quality Management District compliant.

To minimize VOCs in flooring and carpet, wall covering, ceiling tiles, and furniture, it is advisable to use only CA 01350 compliant products. A number of programs currently use the CA 01350 testing protocol to measure the actual levels of individual VOCs emitted from the material and compare it to allowable levels set by the state of California. These include CHPS, CRI's Green Label Plus, SCS's Indoor Advantage, RFCI's FloorScore, and GreenGuard's Children and Schools Certification Program. Try to avoid flooring that requires waxing and stripping, a process which will release more VOCs than the original material. Care should be taken to ensure that there is no added formaldehyde present in all composite wood products and insulation.

Phthalates

Di(2-ethylhexyl) phthalate and other phthalates have attracted considerable adverse publicity for their use in PVC medical products and in toys (although the US Congress banned six kinds of phthalates from toys 8 years ago) and concerns have been raised about their impact on the development of young children. However, phthalates are chemicals that can be found almost everywhere. They are in soaps, plastics, and even cosmetics. Phthalates are also in our foods and are used widely in flexible PVC building materials and have been linked to bronchial irritation and asthma. It is important therefore to avoid using products with phthalates (including PVCs).

Heavy Metals

Even though these metals are known to be health hazards, they continue to be used for stabilizers or other additives in building materials. Lead, mercury and organotins are all known potent neurotoxins, which is particularly damaging to the brains of fetuses and growing children. Cadmium is a carcinogen and can cause a variety of kidney, lung, and other damage. Look therefore for products that do not contain heavy metals that are health hazards.

Halogenated Flame Retardants

The use of flame retardants in many fabrics, foams, and numerous plastics is known to have saved many lives over the years. However, the halogenated flame retardants (HFRs); including PBDEs and other brominated flame retardants (BFRs) have been found to disrupt thyroid and estrogen hormones, which can cause developmental effects, such as permanent changes to the brain and to the reproductive systems. The use of products that have HFRs should be avoided.

Perfluorocarbons

Perfluorocarbons (PFCs) (sometimes referred to as fluorocarbons) are colorless and have high density, up to over twice that of water. Numerous treatments for fabric and some building materials have been based on PFCs that—like the HFRs—are characteristically highly persistent and bioaccumulative and hence are concentrating at alarming levels in humans. PFOA is a major component of treatment products such as Scotchgard, Stainmaster, Teflon, and Gore-Tex, and has been linked to a range of developmental and other adverse health effects. Thus avoid all products that are treated with a PFC-based material.

7.4.2 Resources for Locating Healthy Building Materials

Because of the great diversity of materials used in the construction and manufacturing industries, it is difficult to produce a single building materials list or certification that covers all of the relevant health and environmental issues. For example, the HBN's PVC-Free Alternatives Database (www.healthybuilding.net/pvc/alternatives.html) is a Construction Specifications Institute-prepared listing of PVC-free alternatives for a wide range of building materials. The following list should be useful:

Green Seal-Certified Products: Paints and coatings that meet the GreenSeal VOC (VOCs) content standards are listed; these materials do not contain certain excluded chemicals and meet typical LEED performance requirements.

EcoLogo: Is an environmental standard and certification mark founded in 1988 by the Government of Canada and now recognized internationally. The EcoLogo Program provides customers—public, corporate, and consumer—with assurance that the products and services bearing the logo meet stringent standards of environmental leadership. The EcoLogo Program is a Type I eco-label, as defined by the International

Organization for Standardization (ISO) and has been successfully audited by the Global EcoLabelling Network as meeting ISO 14024 standards for eco-labeling. Products EcoLogo certifies include carpet, adhesives, and paint.

CHPS (Collaborative for High Performance Schools) Low-Emitting Materials: CHPS maintains a table listing products that have been certified by the manufacturer and an independent laboratory to meet the CHPS Low-Emitting Materials criteria—Section 01350—for use in typical classrooms. Certified materials include adhesives, sealants, concrete sealers, acoustical ceilings, wall panels, wood flooring, composite wood boards, resilient flooring, and carpet. Note: This list also includes paint listings, but CA 01350 is not yet a replacement for low VOC screening (www.chps.net/manual/lem_table.htm).

Green Label Plus: This basically confirms that the Carpet and Rug Institute (a trade association) assures customers that approved carpet products meet stringent requirements for low chemical emissions and furthermore, certifies that these carpets and adhesives meet CA 01350 VOC requirements. Thus, any architect, interior designer, government specifier, or facility administrator who is committed to using green building products just needs to look for the Green Label Plus logo as this signifies that the carpet product has been tested and certified by an independent laboratory and meets stringent criteria for low emissions.

FloorScore: Scientific Certification Systems certifies for the Resilient Floor Covering Institute (a trade association) that resilient flooring meets CA 01350 VOC requirements (see www.scscertified.com/iaq/floorscore_1.html).

GreenGuard for Children and Schools: Air Quality Sciences certifies for GreenGuard that furniture and indoor finishes meet lower of CA 01350 VOC or 1/100 of TLV. The GreenGuard Environmental Institute (GEI) has formulated performance-based standards to define goods with low chemical and particle emissions for use indoors; these primarily include building materials, interior furnishings, furniture, cleaning and maintenance products, electronic equipment, and personal care products. The standard establishes certification procedures including test methods, allowable emissions levels, product sample collection and handling, testing type and frequency, and program application processes and acceptance. GEI now certifies products across multiple industries.

BFRs/HFRs and perfluorochemicals (PFCs): Although no listings are yet screened for these emerging problem chemicals, all halogen-based

flame retardants are likely to be problematic. Flame retardants are added to plastics, particularly fabrics and foams. PBDEs are the most widely used.



7.5 IEQ BEST PRACTICES

An overview of the new International Green Construction Codes clearly reaffirms that IEQ is a critical component of sustainable buildings. Ventilation, thermal comfort, air quality, and access to daylight and views are all important factors that play a pivotal role in determining IEQ.

The Architectural and Transportation Barriers Compliance Board (Access Board) which is an independent federal agency devoted to accessibility for people with disabilities contracted with the National Institute of Building Sciences (NIBS) to establish an IEQ Project as a first step in implementing an action plan. The NIBS issued a project report on IEQ released in July 2005 which revealed that a growing number of people in the United States suffer a range of debilitating physical reactions caused by exposures to everyday materials and chemicals found in building products, floor coverings, cleaning products, and fragrances, and others products. This condition is known as MCS. The range and severity of these reactions are very varied. In addition, the Access Board received numerous complaints from other people who report adverse reactions from exposures to electrical devices and frequencies, a condition referred to as electromagnetic sensitivity (EMS).

The Access Board responded to these concerns by sponsoring a study on ways to tackle the problem of IEQ for persons with MCS and EMS as well as for the general population. In conducting this study for the Board, the NIBS brought together a number of interested parties to explore the relevant issues and to develop an appropriate action plan. The report includes among other things, recommendations on improving IEQ that addresses building products, materials, ventilation, and maintenance issues.

The following are some of the steps and best practices that can be applied to ensure good IEQ (portions of this list are excerpted from “Indoor Environmental Quality” Harvard University Campus Services):

- Conduct a faculty-wide IEQ survey/inspection of the facility, noting odors, unsanitary conditions, visible mold growth, staining, presence of moisture in inappropriate places, poorly maintained filters, personal air cleaners, hazardous chemicals, uneven temperatures, blocked vents.
- Determine operating schedule and design parameters for HVAC system and ensure adequate fresh air is provided to prevent the development of

indoor air quality problems and to contribute to the comfort and well-being of building occupants. Maintain complete and up-to-date ventilation system records.

- Ensure that appropriate Preventive Maintenance is performed on HVAC system including but not limited to outside air intakes, inside of air handling unit, distribution dampers, air filters, heating and cooling coils, fan motor and belts, air distribution ducts and VAV boxes, air humidification and controls, cooling towers.
- Manage and review processes with potentially significant pollution sources such as: renovation and remodeling, painting, shipping and receiving, pest control and smoking. Ensure adequate controls are instituted on all renovation and construction projects and evaluate control impacts on IEQ.
- Control environmental tobacco smoke by prohibiting smoking within buildings or near building entrances. Designate outdoor smoking areas at least 25 ft from openings serving occupied spaces and air intakes.
- Control moisture inside buildings to inhibit mold growth, particularly in basements. Dehumidify when necessary and respond promptly to floods, leaks, and spills. Use of porous materials in basements should be monitored and restricted whenever possible.
- When mold growth is evidenced, immediate action should be taken to remediate.
- Choose low-emitting materials with minimal or no VOCs. This particularly applies to paints, sealants, adhesives, carpet and flooring, furniture, and composite wood products and insulation.
- Monitor Carbon Dioxide (CO₂), and install carbon dioxide and airflow sensors in order to provide occupants with adequate fresh air when required.
- To maintain occupants' thermal comfort, include adjustable features such as thermostats or operable windows.
- Window size, location, and glass type should be selected to provide adequate daylight levels in each space.
- Window sizes and positions in walls should be designed to take advantage of outward views and have high visible transmittance rates (greater than 50%) to ensure maximum outward visibility.
- Incorporate design strategies that maximize daylight and views for building occupants visual comfort.
- Educate cleaning staff regarding use of appropriate methods and products, cleaning schedules, materials storage and use, and trash disposal.

- A process for complaint procedures should be established and IEQ complaints promptly respond to.
- Discuss with occupants how they can participate in maintaining acceptable IEQ.
- Permanent entryway systems such as grilles or grates should be installed to prevent occupant-borne contaminants from entering the building.
- Construction IAQ Management Plan should be in place so that during construction, materials are protected from moisture damage and control particulates through the use of air filters.

There are also a number of suggested IEQ-related recommendations that tenants should follow to ensure that all building occupants maintain a healthy indoor environment. These include:

- The use of air handlers during construction must be accompanied by the use of filtration media with a MERV of eight at each return grill as determined by ASHRAE 52.2-1999.
- Replace all filtration media immediately prior to occupancy; conduct when possible, a minimum 2-week flush out with new filtration media with 100% outside air after construction is completed and prior to occupancy of the affected space.
- Contractors to notify Property Manager 48 h prior to commencement of any work which may cause objectionable noise or odors.
- Protect stored on-site materials and installed absorptive materials from moisture damage.
- All applied adhesives must meet or exceed the limits of the South Coast Air Quality Management District Rule #1168. Also, sealants used as fillers must meet or exceed Bay Area Air Quality Management District Reg. 8, Rule 51.
- Ensure that all paints and coatings meet or exceed the VOC and chemical component limits of GreenSeal requirements.
- Ensure that carpet systems meet or exceed the Carpet and Rug Institute Green Label Indoor Air Quality Test Program.
- Composite wood and agrifiber products should not contain any added UF resins.
- Contractors should provide protection and barricades where needed to ensure personnel safety and should comply with OSHA at a minimum.

Finally, it should be remembered that the air quality of a building is one of the most important factors in maintaining employee productivity and health. Toward this end, IEQ monitoring will help minimize tenant complaints of BRI and SBS, and a cohesive proactive IEQ monitoring program

is a powerful tool that can be used to achieve this goal. Several national and international organizations including the EPA, OSHA, ASHRAE, ASTM, USGBC and others are currently in discussions concerning formulating new standards and updating and improving existing national indoor air quality standards.

The following are some relevant standards, codes, and guidelines:

- ASHRAE Standard 62-1999: Ventilation for Acceptable Indoor Air Quality
- ASHRAE 129-1997: Measuring Air-Change Effectiveness
- IgCC
- South Coast Rule #1168, South Coast Air Quality Management District
- Regulation 8, Rule 51 of the Bay Area Air Quality Management District
- Canadian Environmental Choice/Ecologo
- Best Sustainable Indoor Air Quality Practices in Commercial Buildings
- Guidelines for Reducing Occupant Exposure to VOCs from Office Building Construction Materials
- Carpet and Rug Institute Green Label Indoor Air Quality Test Program.



Water Efficiency and Sanitary Waste



8.1 OVERVIEW

The current popularity of sustainability in the building industry has encouraged it to make taking care of natural resources, a part of our everyday culture, so that the concept of conservation of our natural resources has in now become part of society's green culture. Nonetheless, with respect to water efficiency, Randhir Sahni, AIA, president of Llewelyn-Davies Sahni says, "The United States is notoriously water inefficient. For example, there are many development sites that have water and sewer service, but no buildings because the market evaporated or use changed. So what happens? The MUD (municipal utility district) has to put bacteria or animal manure in the sewer plant in order to operate and maintain the facilities."

Among the more prominent issues facing us today is water conservation and using water more efficiently. In this respect, the LEED Water Efficiency (WE) section now addresses water holistically, looking at indoor use, outdoor use, specialized uses, and metering. Likewise, LEED has raised the bar for water conservation and now requires all projects to reduce water use by at least 20% as a prerequisite to LEED certification, whereas earlier versions of LEED awarded a point for a 20% reduction. This prerequisite was first introduced in LEED 2009 and is significantly more demanding plus it does not apply to earlier versions of LEED. The baseline is determined by assuming that all fixtures meet national codes, as laid out on a fixture-by-fixture basis in the credit requirements. As for LEED for Existing Building, the Operations & Maintenance threshold depends on when the facility was originally constructed or last renovated. Of note, those following the same WE requirements as LEED for New Construction include: LEED for Commercial Interiors, LEED for Core and Shell, LEED for Schools, LEED for Retail, and LEED for Healthcare.

Recent Environmental Protection Agency (EPA) estimates place the amount of freshwater, i.e., water needed for drinking, industry, and sanitation at about 2.5% of the world's total. Roughly, one-third of this is readily

accessible to humans via lakes, streams, and rivers. Demand for freshwater continues to rise, and if current trends continue, experts project that demand for freshwater will double within the next three decades. Since 1950, the United States population has increased by almost 90%. In that same time span, public demand for water increased by 209%. Americans now use an average of 100 gallons of water per person each day. This increased demand has put tremendous stress on water supplies and distribution systems, threatening both human health and environment. Reacting to this potential crisis, the South Nevada Water Authority has put into place a Water Efficient Technologies program that offers financial incentives for capital expenditures when businesses retrofit existing equipment with more water-efficient technologies. Likewise, the EPA has launched WaterSense, a water-oriented counterpart to the ENERGY STAR program that promotes water efficiency and aims to boost the market for water-efficient products, programs, and practices.

In addition, local codes are not always keeping pace with some of the new green codes (e.g., the IgCC) and emerging technologies which are not code compliant but are nevertheless available in the marketplace. These include, gray water systems, rainwater collection systems, high-efficiency irrigation systems, recirculating shower systems, regulations controlling hot water delivery, recirculation of hot water, insulation of hot water piping, demand-type tank-less water heaters, water softeners, and drinking water treatment systems, all of which are being implemented through EPA WaterSense. The EPA estimates that toilets account for roughly 30% of the water used in residences, and Americans annually waste 900 billion gallons by the use of old, inefficient toilets. By replacing an older toilet with a WaterSense labeled model, a family of four could reduce total indoor water use by about 16% and, depending on local water and sewer costs, save more than \$90 annually.

Moreover, water conservation translates into energy conservation and savings. By just 1 in every 10 homes in the United States installing WaterSense-labeled faucets or aerators in their bathrooms, in aggregate, this could result in a saving of about 6 billion gallons of water, and more than \$50 million in the energy costs to supply, heat, and treat that water. The EPA also estimates that if the average home was retrofitted with water-efficient fixtures, there would be a savings of 30,000 gallons of water per year. If only 1 out of every 10 homes in the United States upgraded to water-efficient fixtures (including ENERGY STAR-labeled clothes washers), the resultant savings could reach more than 300 billion gallons and nearly \$2 billion annually. This could have a significant positive economic

impact on small plumbing contractors and small businesses throughout the various sectors. In fact, the recent increased demand and focus on water efficiency can provide a powerful catalyst to helping the emerging water and energy conservation market to revitalize these industries across the country at a time when most small business owners are suffering because of tough economic times.

According to Alliance for Water Efficiency, NFP, “Typical water use efficiency categories within many of the national green building programs (guidelines and standards) include:

- Plumbing fixtures and fixture fittings
- Residential appliances (clothes washers, dishwashers)
- Water treatment equipment (softeners, filtering systems)
- Landscape & landscape irrigation
- Pools, fountains, and spas
- Cooling towers
- Decorative and recreational water features
- Water reuse & alternate sources of water (gray water, rainwater and storm water, cooling condensate and cooling tower blowdown, foundation drain water)
- Specialty processes, appliances and equipment (food service, medical, laboratories, laundries, others)
- Metering & submetering
- Once-through cooling
- Vegetated green roofs
- Building water pressure”



8.2 WASTEWATER STRATEGY AND WATER REUSE/RECYCLING

According to the US Department of Energy (DOE) estimates, commercial buildings consume approximately 88% of the potable water in the United States. This offers facility managers a unique opportunity to make a huge impact on overall US water consumption. Benchmarking a facility’s water use and implementing measures to improve overall efficiency will go a long way to achieving this goal. Likewise, in spite of the limited emphasis by LEED on water efficiency, water-efficient design should be one of the main goals of any project, particularly since our nation’s growing population is placing considerable stress on available

water supplies. And even though the US population has nearly doubled in the last five or six decades, public demand for water has more than tripled! This increased demand is adding to the stress on water supplies and distribution systems, and depleting reservoirs and groundwater can put our water supplies, human health, and our environment at serious risk. According to the EPA, lower water levels can contribute to higher concentrations of natural or human pollutants. Using water more efficiently helps maintain supplies at safe levels, protecting human health and the environment.

The US EPA estimates that an American family of four uses about 400 gallons of water per day. About 30% of this is used outdoors for various purposes including landscaping, cleaning sidewalks and driveways, washing cars, and maintaining swimming pools. Nationally, landscape irrigation counts for almost one-third of all residential water use. This amounts to more than 7 billion gallons per day. Water Efficiency is one of the principal categories of the LEED Rating System and the number of WE credits available depend on the type of certification sought, e.g., New Construction, Commercial Interiors, Schools, etc. However, meeting LEED's Water Efficiency Credit 3-Water Use Reduction is no longer a sure thing, even for commercial office buildings. Moreover, recent feedback from GBCI states that municipally treated process water is no longer acceptable for alternative compliance paths for WEp1 and WEc3 (LEED V3), and municipally supplied gray water may not be used to gain water savings in this prerequisite.

For New Construction, a total of 10 possible points (5 points were allotted to previous versions) can be achieved for Water Efficiency (WE) LEED V3 certification (WE Credits for LEED-Homes: Maximum 15 points possible). The main WE categories and topics to know for LEED N/C include the following:

1. WE Credit 1: Water Efficient Landscaping (4 points)
 - a. Reduce by 50% (2 Points)
 - b. No potable use or no irrigation
2. WE Credit 2: Innovative Wastewater Technologies (2 points)
3. WE Credit 3: Water Use Reduction (2-4 points)
 - a. (20%)
 - b. (30%)

Landscaping irrigation is the main source of outdoor water consumption, accounting for about 30% of the 26 billion gallons of daily water consumption. The intent of water-efficient landscaping in the LEED rating system is to reduce (by at least 50%) or eliminate the amount of potable

water consumption and natural surfaces or subsurface water resources available on or near the project site and used for landscape irrigation.

Best practice strategies:

- Use most appropriate plant material for the project climate
- Use native or adapted plants to reduce or eliminate irrigation
- Use high-efficiency equipment when irrigation is required
- Use climate-based controllers

On occasion, landscape design strategies alone are unable to achieve a project's irrigation efficiency goals, in which case attempts should be made to meeting efficiency demands through optimization of the irrigation system design. For example, use of high-efficiency drip, micro and subsurface systems can reduce the amount of water required to irrigate a given landscape. The USGBC reports that drip systems alone can reduce water use by 30–50%. Climate-based controls, such as moisture sensors with rain shutoffs and weather-based evapotranspiration controllers, can further reduce demands by allowing naturally occurring rainfall to meet a portion of irrigation needs. To earn a LEED WEc3 credit, a reduction is needed in the use of potable water for irrigation by 50–100% compared with a baseline irrigation system typical for the region. Because landscape irrigation can account for nearly 40% of the average office building's potable water consumption, reducing or eliminating potable water use for landscaping can save both water and money. For LEED certification, one point is awarded for a 50% reduction in water consumption for irrigation from a calculated mid-summer baseline case, and a total of two points for a 100% water reduction. While LEED V3 has made it increasingly difficult to obtain WE points, it should have a positive impact on architects and plumbing engineers by continually challenging them to develop creative solutions that reduce building potable water consumption.

To facilitate in greening the supply, it is necessary to tap alternate water sources. LEED recognizes two alternate water sources: rainwater collection and wastewater recovery. Rainwater collection involves collecting and holding on-site rainfall in cisterns, underground tanks, or ponds during rainfall. This water can then be used during the dry periods by the irrigation system. Wastewater recovery can be achieved either on site or at the municipal scale. On-site systems capture gray water (which does not contain human or food processing waste) from the building and apply it to irrigation. Reductions shall be attributed to any combination of the following approaches, including:

- Use a high-efficiency microirrigation system, such as drip, micro misters, and subsurface irrigation systems.
- Replace potable (drinking) water with captured rainwater, recycled wastewater (gray water), or treated water.

- Use of water treated and conveyed by a public agency that is specifically used for nonpotable purposes.
- Factor in plant species, density and microclimate and install landscaping that does not require permanent irrigation systems.
- Apply Xeriscape principles to all new development whenever possible. Xeriscaping is the use of low-water, drought-resistant plants and plants that are accustomed to local rainwater patterns.

Additionally, groundwater seepage that is collected and pumped away from the immediate vicinity of foundations and building slabs are eligible for being used for landscape irrigation to meet the intent of this credit. It must be demonstrated, however, that doing so does not impact the site stormwater management systems. When a landscaping design incorporates rainwater collection or wastewater recovery in particular, it is essential to assemble a team of experts and establish project roles at an early stage in the process. Rainwater collection and wastewater treatment systems stretch over multiple project disciplines, making it particularly important to clearly articulate responsibilities. Having an experienced landscape architect on board is pivotal for a water-efficient landscape and irrigation system design. It is highly recommended to plan early to take advantage of the available LEED points for water-efficient landscaping credits.

Several of the LEED credits deal with gray water and blackwater. Gray water has several definitions; it is typically considered to be untreated wastewater that has not come into contact with toilet waste, such as shower water, water from sinks (other than the kitchen), bathtubs, wash basins, and clothes washers. Gray water use generally includes indoor and outdoor reuse. When used outdoors, the gray water is usually filtered and then used for watering landscape. Indoor gray water use on the other hand, consists of recycled water and is used mainly for flushing toilets. Gray water has other applications including construction activities, concrete mixing, and cooling water for power plants. The Uniform Plumbing Code (UPC) defines gray water as untreated household wastewater that has not come in contact with toilet waste, whereas the International Plumbing Code (IPC) defines it as wastewater discharged from lavatories, bathtubs, showers, clothes washers, and laundry sinks; some jurisdictions allow the inclusion of kitchen sinks to be included with gray water. Blackwater lacks a specific definition that is accepted nationwide but is generally considered to constitute toilet, urinal, and kitchen sink water (in most jurisdictions). However, depending on the jurisdiction, implementing gray water systems that reuse wastewater from

showers and sinks for purposes such as flushing of toilets or irrigation may encounter code compliance restrictions.

8.2.1 Reclaimed Water Versus Gray Water Systems

The recycling of water and putting it back to use is commonly thought of in two different water usage strategies: reclaimed water and gray water, and it is important to distinguish between these systems, although some mistakenly use the terms reclaimed water and gray water interchangeably.

Simply put, reclaimed water is wastewater effluent/sewage that has been treated according to high standards at municipal treatment facilities and that meets the reclaimed water effluent criteria. Its treatment takes place off-site and delivered to a facility. Reclaimed water is most commonly used for nonpotable purposes, such as landscaping, agriculture, dust control, soil compaction, and processes such as concrete production and cooling water for power plants. The use of reclaimed water is increasing in popularity, especially in states such as California, where openness to innovative, environmentally friendly concepts prevails especially in the face of a very real and critical water crisis. For example, Orange County, California, has recently started delivering purified wastewater, providing one of the first “toilet-to-tap” systems to be employed in the Nation.

On the other hand, gray water is the product of domestic water use such as showers, washing machines, and sinks and does not normally include wastewater from kitchen sinks, photo lab sinks, dishwashers, or laundry water from soiled diapers. These sources are typically considered to be blackwater producers because they contain serious contaminants and therefore cannot be reused. Moreover, gray water use is a point-of-source strategy, i.e., gray water collected from a building will be reused in the same building.

8.2.2 Innovative Wastewater Technologies

The intent of the Innovative Wastewater Technologies credit is to reduce wastewater generation and potable water demand, and increase the recharge of local aquifers. To achieve this credit requires a 50% reduction of potable water used for building sewage (blackwater) conveyance that is the product of flush fixtures. You can reduce potable water demand by using water-conserving fixtures, reusing nondrinking water for flushing or reuse water treated on-site to tertiary standards (with the treated water infiltrated or used on site). Tertiary treatment is the final stage of treatment before water can be discharged back into the environment. If tertiary treatment is used, the water must be treated by biological systems, constructed wetlands, or

a high-efficiency filtration system. Of note, a Water Efficient Technologies program is now in place that offers financial incentives to commercial and multifamily property owners who install water-efficient devices and implement new, water-saving technologies. Examples of effective Water Efficient Technologies strategies include the following:

- Ultra-high-efficiency toilets and efficient retrofits
- Use efficient showerheads and efficient retrofits
- Waterless and high-efficiency urinals
- Other ultra-low water consumption products
- Converting a sports field from grass to an artificial surface
- Retrofitting standard cooling towers with qualifying, high-efficiency drift elimination technologies

Strategies for meeting one of the Water Efficiency compliance requirements, reducing potable water use for sewage conveyance, falls into two categories that can be implemented either independently or in concert. As shown above, by simply meeting demands efficiently, the use of ultra-high-efficiency plumbing fixtures can reduce the water required for sewage conveyance in excess of the 50% requirement. To use a typical example, composting toilets (not normally used in commercial facilities) and waterless urinals use no water. These two technologies alone can eliminate a facility's use of potable water for sewage conveyance, qualifying both for this credit's point, plus potentially a LEED Innovation in Design point for exemplary performance. Should the selected plumbing fixtures alone prove to be inadequate to reach the 50% reduction threshold, or if ultra high-efficiency plumbing fixtures are not selected, the water necessary for toilet and urinal flushing can be reduced by a minimum of 50%, or eliminated entirely, by applying strategies such as rainwater collection or wastewater treatment.

An excellent example of how this credit can be achieved is provided by the Southface Eco Office in Atlanta, Georgia (Fig. 8.1). The facility, targeting LEED Platinum certification, was able to completely eliminate the use of potable water for sewage conveyance using a variety of complementary strategies. For example, foam flush composting toilets and waterless urinals are used in the staff restrooms; composting toilets require only 6 ounces of water per use, which significantly reduces the volume of water required for sewage conveyance. Water requirements in the public restrooms are also reduced through the employment of a combination of dual flush toilets, ultra-high-efficiency toilets, and waterless urinals. The remaining reduced volume of water required for sewage conveyance is supplied by rainwater collected from a roof-mounted solar array and stored in a rooftop cistern, in addition to a



Figure 8.1 The new Eco Office in Atlanta, Georgia is a 10,000 square feet. facility seeking LEED-Platinum rating, which was designed as a model for environmentally responsible commercial construction that is achievable utilizing existing off-the-shelf materials and technology. The new Eco Office provides a showcase of state-of-the-art energy, water, and waste-reducing features.

supplemental in-ground storage tank. Early involvement of an experienced and knowledgeable team of local code officials are critical components for the successful design and implementation of nonpotable water supply systems. Furthermore, dual-plumbing lines for nonpotable water supply within the building are fairly easy to plan for during the design phase but much more difficult to retrofit after construction is complete and the building occupied.

8.2.3 Water Use Reduction

The intent of the Water Use Reduction credit according to LEED is to “maximize water efficiency within buildings to reduce the burden on municipal water supply and wastewater systems.” One point was previously awarded for reducing water use by 20% (in LEED V3, it is a prerequisite), and this becomes two points for reducing annual potable water use by 30%. Of note, in LEED V3 a 35% saving entitles three points whereas four points can be achieved for a 40% saving. The fixtures governed by this credit include water closets, urinals, lavatory faucets, showers, and kitchen sinks. For water-using fixtures and equipment, such as dishwashers, clothes washers, and mechanical equipment (nonregulated uses), which are not addressed by this credit may qualify for the LEED Innovation in Design point.

The use of proven, cost-effective technologies can facilitate achieving the required percent reduction necessary to earn points for this credit. The use of low-flow lavatory faucets with automatic controls (0.5 gallons per minute (gpm), 12s per use) is normally sufficient to achieve a 20% reduction in water use, qualifying for the prerequisite. An additional 14% reduction can be achieved by the use of waterless urinals which, when combined with low-flow faucets, should exceed the 30% reduction threshold, thereby earning points.

Here too, the first step in the optimization process, reducing demands, does not apply. It's not possible to design away occupants' needs to use the restroom, wash their hands, or take a shower. Strategies for water-use reduction therefore fall into the same two categories identified for Innovative Wastewater Technologies—either meeting demands efficiently or fulfilling the demand in alternate, more environmentally appropriate means. The two credits complement one another and water savings related to the Innovative Waste Water Technology credit will also contribute to the Water Use Reduction credit. John Starr, AIA, and Jim Nicolow, AIA, of Lord, Aeck & Sargent, architects, state that among the LEED Water Efficiency credits, “Water Use Reduction can often be achieved without the early planning and design integration required by the other two credits. Most alternative plumbing fixtures use conventional plumbing supply and waste lines, allowing these fixtures to be substituted for less-efficient standard fixtures at any point in the design process, and even well into the construction process.”

8.2.4 System Approaches

Local municipalities and individual facilities continue to struggle to meet water needs in the face of dwindling water supplies, facilitating the emergence of a variety of reclaimed water and gray water system approaches. These systems range in their size and complexity. Toward the high end are the multibuilding installations that draw wastewater from municipal sources, followed by the middle tier which includes buildings that have installed storage tanks capable of collecting thousands of gallons of water from rainwater, sinks, and steam condensate, which is then treated and funneled to water reuse sources. There are also the more affordable undercounter systems that are simpler and on a smaller, yet significant, scale that carry out on-the-spot treatment of water that flows down sink drains, which is then pumped directly into toilet tanks. More complex systems should be built into new construction rather than retrofitting them at a later date, whereas on-the-spot collection systems can be implemented at any time. It is

important when specifying sustainable systems and technologies to remain within budget as a matter of setting goals and performing research up front to determine the additional value and payoff of the systems being used.

Gray Water Demonstrations

The volume of gray water produced in a particular building depends largely on the type of facility. For example, a typical office building may not yield as much gray water as a college dorm or multiuse retail and condominium building; the benefits are all about economies of scale and deriving value from the system, no matter how large or how small they may be. Let us consider the amount of potable water that a typical four-person household can save. On average, each person uses 80–100 gallons of water per day with toilet flushing being the largest contributor to this use. The combined use of kitchen and bathroom sinks is only 15% of the water that comes into a home, which is significant considering that 100% of the water that comes into the home has been treated and made potable for drinking.

Thus, with the largest single source of freshwater in the home capable of using gray water instead of potable water, the household is able to make real gains on reusing water that is totally appropriate for toilet flushing. For household and small commercial facilities, the best solution may be to use a gray water system that incorporates a reservoir, which is installed under the sink and attached to the toilet. These gray water systems are designed so that the toilet draws first from the collected water in the reservoir. The system remains connected to the freshwater pipes so that, should flushing deplete the amount of water stored in the reservoir, the toilet can then secondarily draw from outside water. Because toilets are the largest consumers of water in households, such systems are able to save up to 5000 gallons per year.

Differing gray water policies and regulations between states are significantly impacting the extent to which facilities and homeowners can deploy gray water systems. The state of Arizona, for example, has gray water guidelines to educate residents on methods to build simple, efficient, and safe gray water irrigation systems. For those who follow these guidelines, their system falls under a general permit and automatically becomes “legal” which means that the residents do not have to apply or pay for any permits or inspections. California, on the other hand, also has a gray water policy but one that is restrictive which usually makes it difficult and unaffordable to install a permitted system. Many states have no gray water policy and do not issue permits at all, whereas others states issue experimental permits for systems on a case-by-case basis.

The term recycling is usually reserved for waste such as aluminum cans, glass bottles, and newspapers. Water can also be recycled and indeed, through the natural water cycle, the earth has recycled and reused water for millions of years. Water recycling, though, generally refers to using technology to speed up these natural processes. The recycling of water by whichever means provides substantial benefits, including reduction of stress on potable water resources, reduction of nutrient loading to waterways, reducing strain on failing septic tanks or treatment plants, using less energy and chemicals, and costing less than potable water. All of these benefits result in significant savings in both water and energy.

Long-Term Savings

It is worth noting that not long ago, purchasing environmentally friendly building components that met LEED compliance standards may have added more than 10% to total building costs, whereas today, plumbers, engineers, and other specifiers are now discovering that they can adopt higher sustainability standards without necessarily incurring extra costs. And where they do have to spend extra, the long-term payoff more than compensates, when you factor in long-term operating costs, including water and wastewater utility bills, plus the energy it takes to heat water for faucets and showerheads, etc.

According to Flex Your Power, California's energy efficiency marketing and outreach campaign, utilities account for about 30% of an office building's expenses. A 30% reduction in energy consumption can lower operating costs by \$25,000 a year for every 50,000 square feet of office space. This has prompted the public to show greater awareness and take greater notice of how companies and facilities expend water and energy; both users and communities are holding building owners accountable for their use of precious local resources. Engineers need to stay abreast and monitor water and energy efficiency options in the restrooms and elsewhere in their facilities to minimize operating costs and help ensure that buildings meet LEED standards as well as the new International Green Construction Code standards (IgCC).

Construction Waste Management

Commercial construction typically generates between 2 and 2.5 pounds of solid waste per square foot—the majority of which is recyclable. Salvaging and recycling Construction and Demolition (C&D) waste can substantially reduce demand for virgin resources and the associated environmental impacts. Additionally, effective construction waste management, including

appropriate handling of nonrecyclables, can reduce contamination from and extend the life of existing landfills. It is important therefore to devise an overall environmental strategy to enable achieving sustainability goals without sacrificing financial objectives. Thus, whenever feasible, reducing initial waste generation is environmentally preferable to reuse or recycling. Most common Construction & Demolition debris can be recycled including concrete, porcelain, plastic, carpet, rigid plastics, tile, lumber, metals, masonry, rock, insulation, and more.

From the outset, the Construction Waste Management Plan should recognize project waste as an integral part of overall materials management. The premise being that waste management is a part of materials management, and the recognition that one project's wastes are materials available for another project, facilitates efficient and effective waste management. Moreover, waste management requirements should be included as a topic of discussion during both the preconstruction phase and at ongoing regular job meetings, to ensure that contractors and appropriate subcontractors are fully aware of the implications of these requirements on their work prior to and throughout construction. Furthermore, waste management should be coordinated with or part of a standard quality assurance program, and waste management requirements should be addressed regularly throughout the project. All topical applications of processed clean wood waste and ground gypsum board as a soil amendment must be implemented in accordance with local and state regulations.



8.3 WATER FIXTURES AND REDUCING WATER STRATEGY

New technologies have flooded today's mainstream market with thousands of plumbing fixtures and fittings which can help save water, energy, and money. Reducing indoor water use in residences and businesses has, in many cases, been accomplished through water-efficiency standards for plumbing fixtures. These standards generally impose a maximum on the amount of water used per flush by toilets and urinals and per minute by faucets and showerheads. In the United States, these amounts or flow rates are described as gallon per flush (gpf) or gpm. These include, but are not limited to, aerators, metering, and electronic faucets and prerinse spray valves. But when selecting energy-efficient equipment, it is vital to select quality products that meet conservation requirements without compromising

performance. The product should deliver the consistent flow required, while maintaining the water and energy savings of the industry demands. And with restroom fixtures accounting for most of a typical commercial building's water consumption, the best opportunities for increasing efficiency can be found there. Fortunately, there is an increased public awareness combined with an increasing number of higher-efficiency plumbing fixtures becoming more widely available.

One of the best ways to increase water efficiency in buildings is through plumbing fixture replacement and implementation of new technologies, particularly since significant water efficiency improvements over conventional practice are now readily achievable. Replacing older, high-flow water closets and flush valves with models that meet current UPC and IPC requirements is important. While current codes require the lower flow rate for new fixtures, existing buildings often have older, high-flow flush valves. Despite the tremendous water savings available by updating the fixtures, facility managers often avoid the upgrade because of concerns about clogging. Solid waste removal must be 350 g or greater. Fixtures Pass or Fail based on whether the fixture can completely clear all test media in a single flush in at least four of five attempts. Toilets that pass qualify for the EPA WaterSense label. It should be noted that when the Energy Policy Act of 1992 was first enacted, many facility managers at the time experienced problems with the low-flow fixtures clogging due to fixture-design issues which have long since been addressed (Tables 8.1a and b).

The value of selecting water-efficient fixtures will not only reduce sewer and water bills, but efficient water use reduces the need for expensive water supply and wastewater treatment facilities and helps maintain healthy aquatic and riparian environments. Moreover, it reduces the energy needed to pump, treat, and heat water. Water is employed in a product's

Table 8.1a Comparison of plumbing fixture water-flow rates

Plumbing fixture	Before 1992	EPA 1992	Current plumbing codes
Toilets	4–7 gpf	1.6 gpf	1.6 gpf
Urinals	3.5–5 gpf	1.0 gpf	1.0 gpf
Faucets ^a	5–7 gpm	2.5 gpm	0.5 gpm
Showerheads ^a	4.5–8 gpm	2.5 gpm	2.5 gpm

^aAt 80 psi flowing water pressure.

Source: Domestic Water Conservation Technologies, Federal Energy Management Program, U.S. Department of Energy, Office of Energy Efficiency and Renewable Energy, National Renewable Energy Laboratory, October 2002.

Table 8.1b National Green Building Standards and Codes. Comparison of specific water use efficiency provisions—maximum water use

Plumbing	CalGreen ^a	ASHRAE SS 189.1	ASHRAE S191 (draft)	ICC-NAHB HOMES	IAPMO Green Plumbing & Mech Code Supplement	ICC Green Code (PV2 draft)
Residential toilets (per flush)	HET: 1.28 g	HET: 1.28 g	HET: 1.28 g	HET: 1.28 g	HET: 1.28 g	HET: 1.28 g + WaterSense
Commercial toilets (per flush)					1.6 g	1.6 g
Urinals (per flush)	HEU: 0.5 g	HEU: 0.5 g	HEU: 0.5 g	HEU: 0.5 g	HEU: 0.5 g	HEU: 0.5 g + WaterSense (if a flushing urinal)
Residential & commercial “private” lavatory faucets (per minute)	1.5 gpm ^b	1.5 gpm	1.5 gpm	1.5 gpm	1.5 gpm	1.5 gpm + WaterSense
Commercial “public” lavatory faucets (per min.)	0.4 gpm	0.5 gpm	0.5 gpm		0.5 gpm	0.5 gpm
Commercial metering faucets (per cycle ^d)	0.20 gpc	0.25 gpc	0.20 gpc		0.25 gpc	0.25 gpc
Residential kitchen faucets (per minute)	1.8 gpm ^c	2.2 gpm	2.2 gpm			2.2 gpm
Residential showerheads (per minute)	2.0 gpm	2.0 gpm	2.0 gpm	2.5 gpm	2.0 gpm	2.0 gpm + WaterSense
Residential showering compartment—size increment		2600 sq.in.	3000 sq.in.		1800 sq.in.	
Commercial prerinse spray valve (per minute)		1.3 gpm	1.3 gpm		1.6 gpm	1.3 gpm

^aPrescriptive option only.^bAlso a minimum flow rate of 0.8 gpm at 20 psi.^cKitchen faucets may “temporarily” flow at 2.2 gpm but must default to 1.8 gpm maximum.^dMetering faucets have *no flow rate maximum*.

Source: Prepared by John Koeller, © 2010–2011 Koeller and Company. Updated: June 2011.

manufacture, during a product's use, and in cleaning, which means that water efficiency and pollution prevention can occur during several product life cycle stages. Mark Sanders, product manager for Sloan Valve Company's AQUUS Greywater System says, Gray water and reclaimed water strategies make good use of water resources, especially when implemented in conjunction with efficient plumbing systems.

The maximum volume of water discharged, using both original equipment tank trim and using after market closure seals, shall be tested according to the protocol detailed on the WaterSense website. There are two primary approaches to measuring Water volume: gallons per flush for toilets and urinals or gallons per minute for flow-type fixtures such as lavatories, sinks, and showers. Metered faucets with controlled flow rates for preset time periods are measured in gallons per cubic yard. The maximum volume of water that may be discharged by the toilet, when field adjustment of the tank trim is set at its maximum water use setting, shall not exceed 1.68 gpf for single flush fixtures and for dual flush fixtures should not exceed 1.40 gpf in reduced flush mode and 2.00 gpf in full flush mode.

For LEED purposes, baseline calculations should be computed by determining the number and gender of the users. As a default, LEED lets you assume that females use toilets three times per day males once per day in addition to using the urinal two times per day. Both males and females will use the bathroom faucets three times each day and the kitchen sink once for 15s each. The following section will discuss the various types of water-efficient fixtures on the market.

8.3.1 Toilet and Urinal Types

By using water more efficiently, we can help preserve water supplies for future generations, save money, and protect the environment.

High-Efficiency Toilets

The signing into law of the National Energy Policy Act in 1994, requiring that toilets sold in the United States use no more than 1.6 gallons (6L) per flush was a significant step in water conservation. This mandate to conserve has encouraged manufacturers to produce a new generation of high-efficiency toilets (HETs) that use technologies such as pressure assist, gravity flush, and dual flush to remove away waste using as little water as possible. Of these new technologies, the dual flush method has the advantage of intuitive flushing, where the operator can decide electively that less water is required and so uses one gallon (3L) or less per flush instead of the 1.6 gallon maximum.

Currently there are two basic types of toilet fixtures that dominate today's marketplace: (1) Ultra-Low Flush Toilets (ULFTs), aka "low flow" or "ultra low flow," and (2) HETs. ULFTs are defined by a flush volume in the range between 1.28 and 1.6 gpf. The HET is defined as a fixture that flushes at 20% below the 1.6 gpf maximum or less, equating to a maximum of 1.28 gpf. Dual flush fixtures are included in the HET category. This 20% reduction threshold serves as a metric for water authorities and municipalities designing more aggressive toilet replacement programs and, in some cases, establishing an additional performance tier for their financial incentives such as rebate and voucher programs. It is also a part of the water-efficiency element of many green building programs that exist throughout the United States. Unfortunately, this standard currently applies only to tank-type toilets. Flushometer valve toilets have yet to be studied in the same way as tank types, and testing for flushometer valves needs to be performed on the flushometer valve with the various bowls on the market so that the pair can then be rated.

Even though toilets purchased for new construction and retrofits are required to meet the new standards, there, nevertheless, remain millions of older inefficient toilets still in use. As water and sewer costs keep rising, low-flow toilets are becoming increasingly attractive to the American consumer, and local and state governments use rebates and tax incentives to encourage households to convert to these new technologies. The advantages of low-flow toilets in conserving water and thus reducing the demand on local water treatment facilities are obvious. According to the EPA, the elimination of inefficient old style toilets would save the nation about 2 billion gallons of water a day. Having a growing population and an antiquated water treatment infrastructure, water conservation will continue to be a major concern to the public.

Dual Flush Toilets

Dual flush toilets can help make bathrooms more environmentally friendly. They handle solid and liquid waste differently from standard American style toilets, giving the user a choice of flushes. It contains an interactive toilet design that helps conserve water that has become popular especially in countries where water is in short supply and in areas where water supply and treatment facilities are older or overtaxed. The EPA estimates that many states will soon experience water shortages as a result of increased water usage and inefficient water management from aging regional infrastructures. Using less water to flush liquid waste while logical may face cultural biases

in the United States that make accepting such an innovative approach to personal waste removal harder to accept. Interest in low flow and dual flush toilets is on the rise in the United States, partly due to increased government regulation and the rising cost of water and the introduction of incentives in many States for making changes in the way we use the commode.

The method that water is used to remove waste from the bowl impacts the amount of water needed to get the job done. Standard toilets use siphoning action, which basically employs a siphoning tube to discharge waste. A high volume of water that enters the toilet bowl when the toilet is flushed fills the siphon tube and pulls the waste and water down the drain. Upon air entering the tube, the siphoning action stops. Dual flush toilets employ a larger trapway (a hole at the bottom of the bowl) and a wash-down flushing design that pushes waste down the drain. Because no siphoning action is involved, the system requires less water per flush, and the larger trapway diameter facilitates the exit of waste from the bowl. Combined with the savings from using only half-flushes for liquid waste, a dual flush toilet can save up to 68% more water than a conventional low-flow toilet. Use of a larger diameter trapway is the main reason a dual flush toilet does not clog as often as a conventional toilet while requiring less water to flush efficiently and able to save more water than a low-flow toilet when flushing liquid waste. However, it should be noted that a dual flush unit is typically slightly more expensive than comparable low-flow toilet designs. Also dual flush toilets typically retain only a small amount of water in the bowl, and flushing does not always remove all the waste. Even in full flush mode, some occasional streaking will occur.

Composting Toilets

These are dry toilets that use a predominantly aerobic processing system that treats excreta, typically with no water or small volumes of flush water, via composting or managed aerobic decomposition. Because they require little or no water to function effectively, they are particularly suitable (although not exclusively) for use as an alternative to flush toilets in locations where mains water and sewerage connections or waste treatment facility are unavailable, or in locations where water consumption needs to be minimized to the greatest extent possible (Fig. 8.2). A composting toilet can save more than 6600 gallons (24,984 L) of water per person a year.

It is estimated that the average American uses 74 gallons (280 L) of water per day, one-third of which splashes down a flushing toilet. Older toilet may swallow up to 7 gallons (26.5 L) per flush, whereas federal law stipulates only

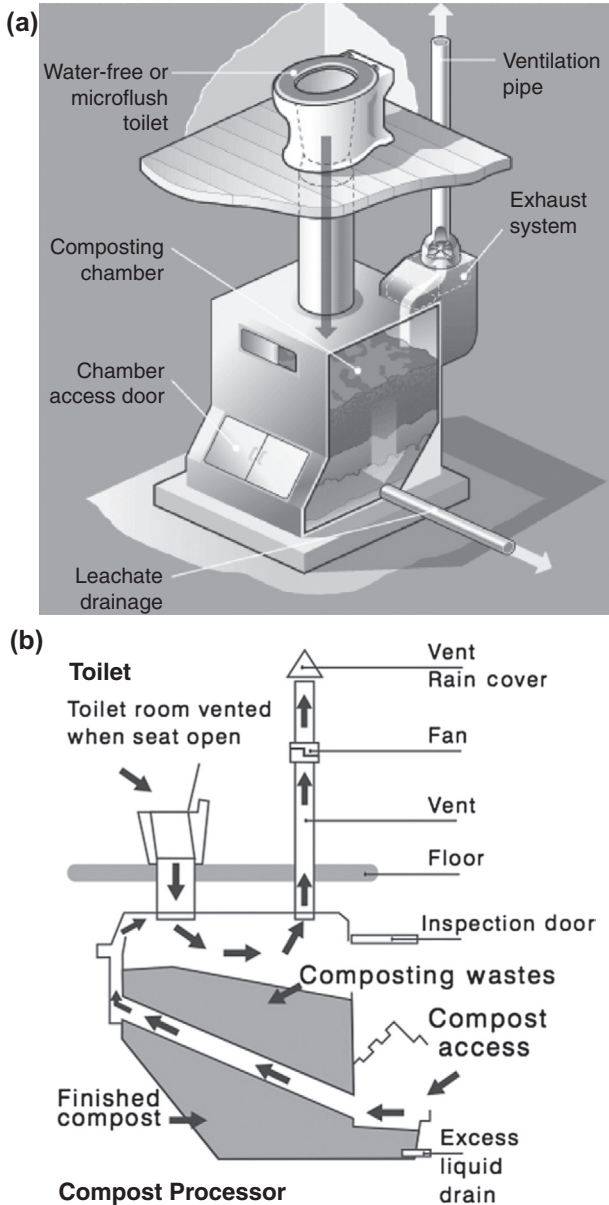

Figure 8.2 Drawing showing how a Composting Toilet works. Composting toilets use the natural processes of decomposition and evaporation to recycle human waste. The waste that enters the toilets is over 90% water, which is evaporated and carried back to the atmosphere through the vent system. The small amount of remaining solid material is converted to useful fertilizing soil by natural decomposition. *Source: HowStuffWorks, Inc.*

1.6 gallon (6.1 L) be used for low-flow models in new homes. Not using water to flush a toilet also cuts out all the energy expended down the line, from the septic system to the treatment plant. That could be beneficial to our waterways.

To function properly, self-contained composting toilets require appropriate ventilation that can keep the smell out of the bathroom while providing enough oxygen for the compost to break down. Some toilets achieve this by employing fans and a heater powered by electricity (some models do not require electricity). The composter also has to be kept at a minimum temperature of 65° Fahrenheit (18.3° Celsius), so for those living off the grid, a heater could potentially require more electricity than used in the rest of the house. The heater does not have to run all the time, however, and one model may only operate at a maximum level of 540 watts for about 6 h a day. As self-contained models are relatively small, the power needed for fans is fairly minimal. It may need from about 80 to 150 watts, which is roughly the same amount of power used by a light bulb. The use of solar panels to power the fans and heater are possible alternatives.

High-Efficiency Urinals

High-Efficiency Urinals (HEUs) are urinals that use 0.5 gpf or less—at least one half of the amount of water used to flush the average urinal (i.e., as opposed to the baseline value of 1.0 gpf). The California Urban Water Conservation Council (CUWCC), in cooperation with water authorities and local agencies, defined them as fixtures that have an average flush volume lower than the mandated 1.0 gpf and zero water consumption urinals. Based on data from studies of actual usage, these urinals save 20,000 gallons of water per year with an estimated 20-year life. HEUs therefore not only help the environment but are making a significant difference in water usage and water bills. In addition to the HEU, there are **Ultra-Low Water Urinals** that utilize only one pint (0.125 gallons) of water to flush. These systems combine the vitreous china fixture with either a manual or sensor-operated flush valve.

They provide effective, low-maintenance flushing in public restrooms while reducing water consumption by up to 88%.

Water-Free Urinals

Water-Free Urinal technologies represent the highest amount (100%) of water savings available. Likewise, with Water-Free Urinals, we see a significant improvement over traditional urinals in both maintenance and hygiene, in

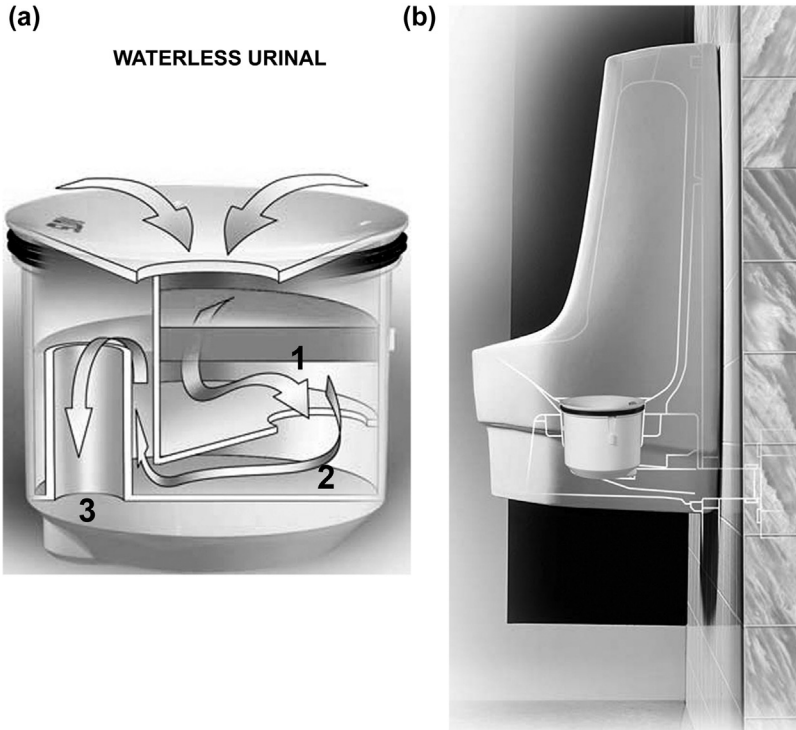

Figure 8.3 (a) Illustration of a waterless urinal diagram showing how it functions: 1. The cartridge acts as a funnel directing flow through the liquid sealant. 2. Preventing any odors from escaping. The cartridge then collects uric sediment. 3. (b) The remaining liquid which is noncorrosive and free of hard water is allowed to pass freely down the drainage pipe. *Courtesy: Sloan Valve Company.*

addition to saving water as well as sewage and water supply line costs. Water-free and HEUs are part of the next generation of water-efficient plumbing products and contribute to US Green Building Council LEED (Leadership in Energy Efficient Design) Credits for water use reduction. These fixtures employ a special trap with lightweight biodegradable oil that lets urine and water pass through but prevents odor from escaping into the restroom (Fig. 8.3). Also, there are no valves to fail and no flooding. Periodic maintenance is required to clean the fixture and maintain the liquid seal device. Installation is easy whether in new or retrofit applications. The initial cost of a Water-free Urinal is often less than conventional no-touch fixtures, lowering your initial investment. The urinal can be used to accumulate water-efficient LEED credits, including innovation points. In lieu of no-water urinals, gray water or rainwater harvesting also could be implemented.

On the other end of the spectrum, we find that wash down urinal treads have steadily decreased flush volume to 0.125 gpf. And while this has helped save significant amounts of water, the marginal flush volume fails to provide enough water to fully flush out the system. This can result in excessive odor and calcite clogged trapways and drain lines.

8.3.2 Faucets and Showerheads

The EPA Act 1992 includes specific requirements for faucet flow rates. For example, residential lavatory faucets must be regulated by an aerator to 2.2 gpm or less, kitchen faucets to 2.5 gpm or less. LEED V3 has adjusted the baseline rate for public faucets from 2.2 gpm down to 0.5 gpm. The updated baseline standard applies to V3 editions of LEED-NC, LEED-CS, LEED-Schools, and LEED-CI systems. The V3 system distinguishes between “public” and “private” commercial restrooms and residential bathrooms. Commercial faucet requirements will vary according to fixture type: handle-operated models are regulated by aerator to 0.5 gpm, whereas self-closing and sensor-operated models are limited to less than 0.25 gallons per cycle. However, today we find that the technology available greatly exceeds EPA Act regulations. While kitchen faucets may require about a 2.5 gpm flow rate to fill a pot in a timely fashion, studies have shown that residential lavatory faucets would be satisfactory for the user even when reduced to even a 0.5 gpm flow rate, and conservation-minded specifiers have started to recommend aerators that deliver this flow rate.

Electronic Faucets

Use of these faucets is an easy way to save energy, and although they are more costly than a traditional faucet, it will pay for itself in water and energy savings in a short period of time. The electronic faucet has a sensor feature which prevents it from being left on and from excess dripping. According to EnergyStar.gov, “hot water leaking at a rate of one drip per second from a single faucet can waste up to 1661 gallons of water over the course of a year.” Electronic faucets typically come equipped with several standard features, including the choice of electric plugin (AC) and battery (DC) battery power options. Of note, recent research has shown that electronic faucets are more susceptible to contamination with bacteria (especially *Legionella*), than manual faucets, and may pose a potential risk for healthcare-associated infections, which has led to their cancellation in several newly constructed hospitals.

Metering Faucets and Aerators

These are less expensive than electronic faucets, yet can deliver similar energy-saving results. Metered faucets which are more common in commercial washrooms are generally mechanically operated fixtures that deliver water (at no more than 0.25 gal/cycle), and then self-close. The manual push feature prevents faucets from being left on after use and prevents unnecessary waste while scrubbing hands. The typical metering faucet's cycle time can be adjusted to deliver the desired amount of water per minute. Many of these devices are designed to allow the user to adjust the temperature before operation. However, in the majority of commercial washrooms sensors are increasingly becoming the standard. But engineers appear to have reached the limit of water efficiency for sensor models: 0.08 gallons per cycle. However, it is not user demand or engineering limitations that have determined this to be the limit; it is due to the fact that other environmental considerations come into play.

Aerators add air into the water stream to increase the feeling of flow, and they are a very common faucet accessory. Aerators are capable of controlling the flow to less than 1.5 gpm and provide a simple and inexpensive low flow/energy solution. They come in a variety of models to provide the exact flow that complies with local plumbing codes.

Flow-Optimized Showerheads

Conventional showerheads use 2.5 gpm, so any shower head that has a lower flow can be considered water efficient. There are many water-saving showerheads on the market that use much less than this, at 1.5 gpm, which produce significant water and cost savings. A 10-min shower can use between 25 and 50 gallons of water because a typical high-flow showerhead uses between 6 and 10 gpm. The flow-optimized single- and three-function showerheads have a flow rate of 1.75 gpm, making it one of the first water-efficient showerheads to offer up to a 30% water savings from the industry-standard 2.5 gpm showerheads without sacrificing performance. This can also contribute toward maximizing LEED points.

The flow rate of 2.5 gpm is both the EPA requirement and the LEED baseline (Baseline basically means that fixtures and appliances should use less water than these to be considered "water efficient"). Attempts to reduce the flow rate still further are mostly met with very unhappy users. Some users even remove the flow restrictors from their fixtures, producing rates of 4–6 gpm, which is clearly not green by any standard. Likewise, flow rates below 2.5 gpm risk failure of certain types of thermostatic mixing valves,

leading to scalding of the user. Before specifying valves and showerheads, it may be prudent to consult the manufacturer of the valve; the information may help alleviate this problem altogether.

8.3.3 Baseline Water Consumption Calculations

To achieve the WE LEED credit, one must first determine the baseline model for water usage in the building. The primary factors in determining this calculation are the types of fixtures in the building, the number of occupants and the flow or flush rate for the specified fixtures. When evaluating a building's water-use efficiency, the USGBC offers a helpful method that allows one to benchmark annual water use and compare that use to current standards.

Establishing Full-Time Equivalent Occupants' Water Use

First one must establish water use based on past annual-use records or on estimates of building occupancy. This should be followed by estimating a theoretical water-use baseline based on the types of fixtures in the building and the number of building occupants. To determine the number of occupants in the building, the number of **Full-Time Equivalent (FTE)** building occupants must be known (acquired from the LEED administrator). The FTE will typically be broken down 50/50 for men and women except in cases where the type of building is meant primarily for one gender, for example, a gym for women. In cases that do not adhere to a strict 50/50 split principal for male and female occupants, an explanation of the design case ration is recommended. This can be included in the narrative section of the LEED online template for this credit. The FTE should include the transient (visitors) building occupants who the building is designed for, in addition to the primary occupants. Projects that will contain both FTE and transient occupants, separate calculations will be required for each type of occupancy.

In [Table 8.2](#), we see an example used by the USGBC to illustrate the calculation process. It represents potable water calculation for sewage conveyance for a two storey office building with a capacity of 300 occupants. The calculations are based on a typical 8-h workday and a 50/50 male/female ratio. Male occupants are assumed to use water closets once and urinals twice in a typical work day (default), and females are assumed to use water closets three times (default). The reduction amount is the difference between the design case and the baseline case.

In [Table 8.3](#), we show the baseline case being used in line with the Energy Policy Act of 1992 fixture flow rates. When undertaking these

Table 8.2 Design case for water use calculation

Fixture type	Daily uses	Flow rate (GPF)	Occupants	Sewage generation (gal)
Low-flow water closet (male)	0	1.1	150	0
Low-flow water closet (female)	3	1.1	150	495
Composting toilet (male)	1	0.0	150	0
Composting toilet (female)	0	0.0	150	0
Waterless urinal (male)	2	0.0	150	0
Total daily volume (gal)				495
Annual work days				260
Annual volume (gal)				128,70
Rainwater or gray water volume (gal)				(36,000)
Total annual volume (gal)				92,700

Source: USGBC.

Table 8.3 Baseline case. The USGBC requires that the baseline case must use the flow rates and flush volumes established by EPAAct 1992

Fixture type	Daily uses	Flow rate (GPF)	Occupants	Sewage generation (gal)
Water closet (male)	1	1.6	150	240
Water closet (female)	3	1.6	150	720
Urinal (male)	2	1.0	150	300
Total daily volume (gal)				1260
Annual work days				260
Total annual volume (gal)				327,600

Source: USGBC.

calculations, the number of occupants, number of workdays, and frequency data should remain the same. Furthermore, gray water or rainwater harvesting volumes should not be included. The baseline case in [Table 8.3](#) estimates that the amount of potable water per year used for sewage conveyance to be 327,600 gallons. This means that a reduction of 72% has been achieved in potable water volumes used for sewage conveyance. Using this strategy can earn one point in LEED's rating system.

Of note, the baseline calculation is based on the assumption that 100% of the building's indoor plumbing fixtures comply with the requirement of the 2006 UPC or the 2006 IPC fixture and fitting performance requirements. Once the baseline has been established for the building, the actual use can be compared and measures can be implemented to reduce water use and increase overall water efficiency. Although this baseline methodology is specific to LEED, it can nevertheless be used in buildings that are not seeking LEED certification.

For calculation purposes on LEED projects, the precise number of fixtures is not important unless there are multiple types of the same fixture specified throughout the building. For example, if there are public restrooms with different water closets on the second floor, their use is to be accounted for as a percentage of the FTE in the LEED credit template calculations. By applying the Energy Policy Act's fixture and flow rates to Full Time Equivalent (FTE) building occupants, the baseline quantity use can be established. To determine the estimated use by the building occupants, FTE calculations for the project must be used consistently throughout the baseline and design case calculations to determine the estimated use by the building occupants.



8.4 RETENTION AND DETENTION PONDS, BIOSWALES, AND OTHER SYSTEMS

Stormwater runoff is generally generated when precipitation from rain and snowmelt events flows over land or impervious surfaces and is unable to percolate into the ground. As the runoff flows over the land or impervious surfaces (paved streets, parking lots, and building rooftops), it accumulates debris, chemicals, sediment, or other pollutants that could adversely affect water quality if the runoff is discharged untreated. The most appropriate method to control stormwater discharges is the application of best management practices (BMPs). Because stormwater discharges are normally considered point sources, they will require coverage under an NPDES permit. Utilizing rainwater collection systems such as cisterns, underground tanks, and ponds, can substantially reduce or eliminate the amount of potable water used for irrigation. Rainwater can be collected from roofs, plazas, and paved areas and then prior to its use in irrigation should be filtered by a combination of graded screens and paper filters.

A retention pond essentially consists of a body of water that is used to collect storm water runoff for the purpose of controlling the release of this runoff. They have no outlets or streams, creek ditches, etc., and after the water collects, it is then released through atmospheric phenomenon such as

evaporation or infiltration. Moreover, retention ponds differ from detention ponds in that a detention pond has an outlet such as a pipe to discharge the water to a stream. A detention pond is similar to a retention pond in that it is a body of water that is used to collect storm water runoff for the purpose of controlling the release of this runoff. However, the pipe that a detention pond contains is sized to control the release rate of the storm water runoff. Although neighborhood ponds serve several purposes, none of these include swimming or wading.

It is important that the pond is of sufficient depth (at least 8–10 feet) to prevent stagnation and algae growth, and to handle the amount of storm-water runoff that is expected to enter it. Most ponds typically have a “safety ledge” at the edge to keep those who unintentionally enter the pond from getting into deep water immediately. This safety ledge is generally no wider than 10 feet and leads directly to much deeper water. The slope off the safety ledge varies greatly, as does the depth of water it leads to. A typical problem that is encountered with ponds is the buildup of bacteria like *Escherichia coli*. Because of the limited water flow and the tendency of wildlife like geese to gather around ponds, they can become breeding grounds for dangerous bacteria. With proper design and maintenance, ponds can be very attractive, but it may require extra planning and more land. It should be noted that some years ago, most detention ponds were nothing more than ugly holes in the ground hidden as far from view as possible. Today, most developers are attempting to incorporate their detention ponds as amenities, whether they have a permanent pool, walking trails, picnic areas, or playgrounds, and so forth. Indeed, ponds today have become less a “waste of land” and more a beneficial use of land, but without maintenance, these ponds can still turn into major liabilities.

Local requirements for rainwater harvest and wastewater treatment will vary from location to location and jurisdiction to jurisdiction, which is why early involvement and input from local code officials is important. The owner should assemble an experienced team, including the architect, landscape architect, civil and plumbing engineers, and rainwater system designer, early in the design process, if realistic efficiency cost-effective goals are to be achieved. Developers will often try to do away with retention ponds and replace them with pervious concrete pavement which while perhaps more expensive than typical concrete pavement, the cost can be partially or fully offset by reducing or eliminating the need for drainage systems and retention ponds and their associated maintenance costs. In addition to the cost savings, elimination of retention ponds can also help meet the goal of reducing site disturbance found in LEED and therefore help earn additional LEED points. Whether it is practical to incorporate detention ponds or

not will depend largely on site development, not large-scale land development. Costs of building a detention versus traditional detention should be studied, bearing in mind that the same storage volume will have to be provided. Then, after adding the cost for pumps, controls, additional storage, and thousands of linear feet of pipe, the decision needs to be made whether all that extra cost outweigh the cost of losing say, 12–15% of your land for a traditional detention pond. Historically, this water was conveniently forced into the city storm drains or into retention ponds, thus becoming someone else's problem. Water from rainstorms and snowmelt needs to be carefully managed to conserve water in time of need, to better clean water before it starts its journey back to local aquifers, and to lessen the burden of excessive water runoff on municipal system drainage systems.

A system of interlocking, porous pavers resting on a multilayer bed of crushed stones and gravel of different sizes can be used for the parking area. This will allow water to diffuse through the surface of the parking lot, slowing the rush of water into the ground, and permitting the surrounding landscaping to absorb the water while being diverted toward bioswales surrounding the property. Bioswales are gently sloped areas of the property designed to collect silt and other rainwater runoff while slowing down the speed with which water collects (Fig. 8.4). The swales are designed so that water is diverted in a manner so as not to encourage erosion of the ground

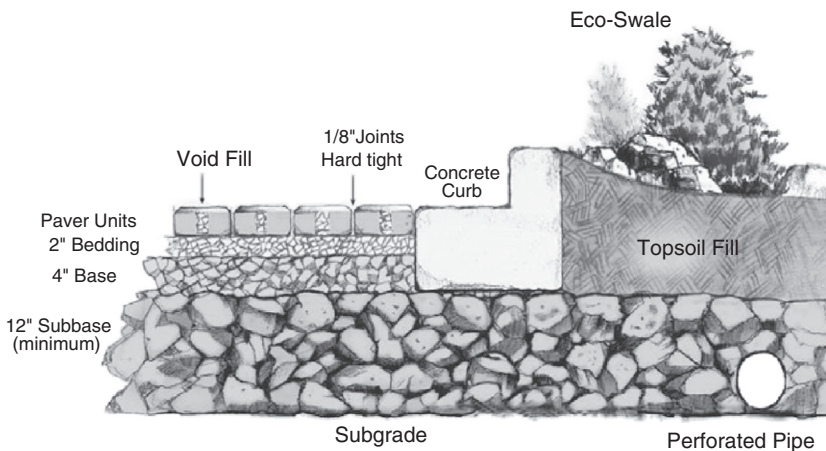

Figure 8.4 Drawing of a typical Bioswale. These consist of gently sloped areas of the property designed to collect silt and other rainwater runoff—and slow down the speed with which water collects. The swales are shaped so that water is diverted but not so sharply as to encourage erosion of the ground and soil. *Source: Other World Computing.*

and soil. The planting of native vegetation in the bioswale can facilitate water absorption, and lengthy root systems can help prevent soil erosion while needing minimum maintenance. The advantage of native plants is that they are hearty and can manage well during periods of dry, hot weather, yet manage to make use of and manage the flow of water from unexpected storms. This ability to combine nature with a well planned surface system can make for an attractive design in addition to being an extremely efficient source of water management and filtering.



Impact of Energy and Atmosphere



9.1 GENERAL INTRODUCTION

Most buildings and facilities today rely on the operation of mechanical and electrical systems to maintain a high level of indoor environmental quality for a building's occupants. Moreover, according to the U.S. Department of Energy (DOE) building operations consume an estimated 40% of the energy and 74% of the electricity produced annually in the United States. Yet the United States often relies on outdated, inefficient power systems that fail to balance energy supply and demand. It is now becoming critically important to revise our approach toward sustainability and green building and to make our buildings more cost-effective and healthy places to live and work in. As previously discussed, this can now be achieved through the use of green strategies such as the integrated design processes that enable the creation of high-performance buildings wherein all systems and components work together to produce overall functionality and environmental performance while meeting the needs of both owner and tenant. However, property developers, design professionals, and so forth are increasingly turning to green building practices, mainly because green buildings reduce the environmental impact of construction, and improve the health and wellness of occupants. It is no secret that green building clearly represents the future of the American construction industry, and it is already creating a wealth of new opportunities and challenges. Moreover, green construction practices can also open doors to receiving local and state financial incentives. In addition, through integrated design we can now create "Net Zero Energy Buildings" (NZEB): buildings that, on an annual basis, draw from outside sources equal or less energy than produced on site from renewable energy sources. There is also the need to adhere to codes designed to protect the environment, conserve energy, and preserve natural resources. The recently launched International Green Construction Code (IGCC) by the International Code Council (ICC) is an example and addresses many of these issues. The intent of the IGCC is to significantly reduce energy usage and greenhouse gases through mandatory green

building design and performance in new and existing commercial buildings. Other primary objectives of the IGCC include preserving natural and material resources both in site development and in land use, in addition to improving indoor air quality (IAQ), supporting the use of energy-efficient appliances, and renewable energy systems, as well as water resource conservation measures.

Thus, because greenhouse gases are directly contributing to air pollution and climate change, there is an urgent need to jump on the green bandwagon. This is becoming even more pressing when we realize that in the United States alone, there are nearly 5 million commercial buildings. Furthermore, commercial buildings and residential buildings together account for roughly 1/3 of all energy consumed, as well as being responsible for 2/3 of the total electricity used within the United States. This is why it is so important for companies to incorporate green construction and green systems. Still, we have yet to see how implementation of the new 2012 IGCC will impact green building systems. Rob Watson, Founding Father of LEED and an International Pioneer in the Modern Green Building Movement, says, "Buildings are literally the worst thing that humans do to the planet. Nothing consumes more energy; nothing consumes more materials; nothing consumes more drinking water, and human beings spend up to 90% of their time indoors so if they are getting sick from their environment, in fact, they are getting sick from their indoor environment not from their outdoor environment." Watson also believes that it is necessary for us to change our paradigms and way of living.

It is important to understand the many aspects that impact the design and construction of creating green buildings that are both healthy and cost-effective. First, however, it would be prudent to overview of the new LEED V3 and V4 Rating systems, particularly as they apply to the Energy and Atmosphere (EA) category and also a brief discussion of some of the changes and new requirements for acquiring LEED credits in this category. It is important to note that many of the exam questions in the LEED exam tend to focus on the energy credits, especially strategies to optimize energy performance. It would therefore be especially prudent to pay particular attention to this category. For the latest updates relating to the LEED 2009 and LEED V4 certification and test requirements, visit the GBCI and USGBC websites: www.gbci.org; www.usgbc.org.

The LEED V3 requirements have changed significantly from its predecessor, with an increased emphasis on sustainable sites, water efficiency, and EA. In terms of possible credits and points, EA must be considered the

Table 9.1 Table showing point allocation for different categories in LEED 2009 rating system

Credit	NC	CI	EB	C&S	Schools
Sustainable sites	26	21	26	28	24
Water efficiency	10	11	14	10	11
Energy and atmosphere	35	37	35	37	33
Materials/resources	14	14	10	13	13
Indoor environmental quality	15	17	15	12	19
Innovation in design	6	6	6	6	6
Regionalization	4	4	4	4	4
Total points	110	110	110	110	110

most important of the seven categories in the new LEED 2009 Rating System. For certification purposes, EA can now earn up to 35 points out of 100 + 10 (Table 9.1). It should be stressed however that no individual product or system in itself can be LEED certified; they can only help contribute to the completion of LEED credits. The significance of the dramatic changes to the LEED 2009 scoring system cannot be overstated, particularly in how it relates to energy modeling. Energy and Atmosphere Prerequisite 2 (minimum energy performance) and Credit 1 (optimize energy performance) have changed significantly. Thus, the threshold for the prerequisite has changed from 14% to 10% and the points awarded in the optimize energy performance credit have increased from a 1–10 point scale to a possible 1–19 point scale, awarding basically nine extra points for same percentage improvement over the baseline building. But what is perhaps even more interesting is that the baseline itself has changed. LEED project teams are mandated to use the ASHRAE Standard referenced in the applicable Reference Guide and are permitted to use addenda within the most recent Supplement to that Standard. The new LEED V3 is largely governed by the 2007 update of ASHRAE 90.1 (as opposed to the previous version, ASHRAE 90.1 2004). The main modifications relating to LEED requirements include mandatory compliance with Appendix G of ASHRAE 90.1 2007.

Building construction values in the United States have over the years, become stricter. For example, in climate zone 3A, minimum compliance for roof insulation has increased from R-15 to R-20 and wall insulation has increased from R-13 to R-16.8. Although glass compliance has remained unchanged, different U-values have been introduced based on the type of glass with the former assembly values of U-0.57 and SHGC-0.25 remaining consistent. Thus, using highly efficient glass remains an appropriate method

for earning percentage points against the baseline. The significance of this change will be dramatically increased in building types where skin loads represent a large percentage of the peak heating, ventilating, and air conditioning (HVAC) load (i.e., office buildings), but be less significant in spaces where persons and ventilation loads dominate the sizing of the HVAC equipment such as in schools and assembly areas.

In the United States, many state and local governments adopt commercial energy codes to establish minimum energy efficiency standards for the design and construction of buildings, and the majority of these energy codes are based on ASHRAE 90.1 or IECC. It should be noted that several organizations have also produced standards for energy-efficient buildings, but ASHRAE and the U.S. Green Building Council (USGBC) are perhaps the best known. ASHRAE Standard 90.1—2007, *Energy Standard for Buildings Except Low-Rise Residential Buildings* was established by the USGBC as the commercial building reference standard for the updated rating program, LEED 2009 (Leadership in Energy and Environmental Design) that launched on April 27, 2009. The latest ASHRAE version is the last in a long succession to the original ASHRAE Standard 90-1975 standard, which is becoming increasingly more stringent.

To qualify for LEED certification, HVAC control systems and lighting control system earn very few points on their own, perhaps three points or so. However, with the addition of the necessary sensors and building controls, the number of achievable points grows considerably—to as much as 25 points and even more with the use of fully integrated building systems. This is because with integrated systems, the building can earn multiple LEED points as well as cost savings by taking such measures as having a zone's occupancy sensor to control both the HVAC and the lighting systems. A comprehensive building operation plan needs to be developed that addresses the many systems heating, cooling, humidity control, lighting, and safety systems. Additionally, there is a need to develop a building automation control plan as well. Energy efficiency measures are recommended to ensure that the building will have the highest percentage of energy savings below the baseline building for the lowest upfront capital costs. Some of these recommended measures may involve minor up front capital costs.

The EA Credit 3 for Commercial Interiors: Measurement and Verification—points can be earned by one of two ways: for projects less than 75% of the total building area, either by having submetering equipment installed to measure and record energy use within the tenant space (2 points) or by negotiating a lease whereby the tenant pays the energy costs

and which are not included in the base rent (3 points). OR for projects that constitute 75% or more of the total building area, continuous metering equipment is installed for one of several end uses such as lighting systems and controls or boiler efficiencies (5 points). Some of the other topics that require close attention in preparing for the LEED exam in the EA category are discussed below (For latest LEED addenda updates, visit: <http://www.usgbc.org/articles/leed-addenda-update-january-2016>).

LEED EA Prerequisite 1: Fundamental Commissioning of Building Systems—Basically, the commissioning plan involves verification that the facility's energy-related systems are all installed, calibrated, and are performing according to the Owner's Project Requirements (OPR) and Basis of Design (BOD). The building is to comply with the mandatory and prescriptive requirements of ASHRAE 90.1 2007 in order to establish the minimum level of energy efficiency for the building type. The plans and data produced as a result of the building commissioning will lay the groundwork for later energy efficiency savings. This prerequisite is discussed in detail in [Chapter 5](#). This is an extremely important prerequisite and should be completely understood. Several questions on this subject frequently turn up on the exams.

LEED EA Prerequisite 2: Minimum Energy Performance—The intent of this prerequisite is to establish the minimum level of energy efficiency for the project. It is important to remember here to comply with both the mandatory and prescriptive provisions of ASHRAE 90.1-2007 or State Codes, whichever is more stringent.

LEED EA Prerequisite 3: Fundamental Refrigerant Management—The intent is to reduce ozone depletion. This can be achieved by zero use of chlorofluorocarbon (CFC)-based refrigerants in new heating, ventilating, air conditioning and refrigeration (HVAC&R) systems. For existing construction a comprehensive CFC phase-out conversion prior to project completion is required if reusing existing HVAC equipment (Montreal Protocol—1995).

LEED EA Credit 1: Optimize Energy Performance—The intent is to increase levels of energy performance in comparison to prerequisite standards. Option 1: Whole Building Energy Simulation using an approved energy modeling program (1–19 Points for NC and Schools and 3–21 Points for SC). Option 2: Prescriptive Compliance Path—Comply with ASHRAE's Advanced Energy Design Guide (1 point) appropriate to the project scope; facility must be 20,000 sq. ft. or less and must be office occupancy or retail occupancy. Option 3: Prescriptive

Compliance Path: Advanced Buildings “Core Performance” Guide (1–3 Points). Facility must be less than 100,000 sq. ft.

Exemplary Performance: For project teams pursuing Option 1, new construction must exceed ASHRAE 90.1 2007 Appendix G baseline performance rating by 50% (previously 45.5% for NC) and for existing buildings by 46% (previously 38.5% for NC) to be considered under the Innovation in Design category.

LEED EA Credit 2: On-site Renewable Energy (1–7 points for NC and schools and 1–4 for CS)—The intent is to encourage increase of renewable energy self-supply and reduce impacts associated with fossil fuel energy use. For the minimum renewable energy percentage for each point threshold, see reference guide.

Exemplary Performance: On-site Renewable Energy—For NC and Schools, projects can earn credit for exemplary performance by showing that on-site renewable energy accounts for at least 15% of annual building energy cost. For the CS category, the on-site renewable energy must account for at least 5% of the annual building energy cost to earn an exemplary performance credit.

LEED EA Credit 3: Enhanced Commissioning: This credit (2 Points) is discussed in [Chapter 5](#). The basic intent is to begin commissioning process early in the design process and implement additional activities after systems performance verification.

Exemplary Performance: Enhanced Commissioning: For NC, CS, and Schools, projects that conduct comprehensive envelope commissioning may be considered for an innovative credit. These projects will need to demonstrate the standards and protocol by which the envelope was commissioned.

LEED EA Credit 4: Enhanced Refrigerant Management (2 Points for NC and CS and 1 Point for Schools)—The intent is to reduce ozone depletion while complying with Montreal Protocol. Option 1: Do not use refrigerants. OR Option 2: Select refrigerants and HVAC&R that minimize or eliminate the emission of compounds that contribute to ozone depletion and global warming. Meet or exceed requirements set by the maximum threshold for the combined contributions to ozone depletion and global warming potential (GWP).

LEED EA Credit 5: Measurement and Verification (3 Points for NC and 2 Point for Schools)—The intent is to provide for ongoing measurement and accountability of building energy consumption. Option 1: Develop and implement a measurement and verification

(M&V) plan consistent with Option D: Calibrated Simulation as specified in the International Performance Measurement & Verification Protocol (IPMVP) Volume III: Concepts and Options for Determining Energy Savings in New Construction, April 2003. The M&V period must last not less than 1 year of postconstruction occupancy. OR Option 2: Develop and implement an M&V plan consistent with Option B IPMVP Volume III: Concepts and Options for Determining Energy Savings in New Construction, April 2003. The M&V period must last not less than 1 year of postconstruction occupancy.

LEED EA Credit 6: Green Power (2 Points for NC, CS, and Schools)—The intent is to encourage and develop the use of grid source, renewable energy technologies. Option 1: Use the annual electricity consumption results of EA Credit 1: Optimization Energy Performance to determine baseline electricity use. OR Option 2: Determine the baseline electricity consumption by using the DOE Commercial buildings Energy Consumption Survey database. Renewable Energy Certificates (RECs) provide the renewable attributes associated with green power. RECs can be provided at a much more competitive cost than from local utilities. A facility is not required to switch its current utility in order to procure off-site renewable energy for this credit.

Exemplary Performance: Green Power—For NC, CS, and Schools, projects that purchase 100% of their electricity from renewable sources may be considered for an innovation design credit.

Finally, fire protection systems should never be comprised as they serve the purpose of life safety. However, just like other building systems, they should be designed, sourced, installed, and maintained in a manner that is environmental friendly and reduces their impacts on the environment as discussed in [Section 9.7](#) of this chapter.



9.2 THE BUILDING ENVELOPE

Wikipedia defines the Building Envelope as “A building envelope is the physical separator between the conditioned and unconditioned environment of a building including the resistance to air, water, heat, light, and noise transfer.” The building envelope consists essentially of all the exterior elements of a building, i.e., roof, exterior walls, foundations, windows, doors, and floors of a structure. These elements together form a barrier that separates the interior of the building from the outdoor environment. There are four basic functions of the building envelope.

These include adding structural support, controlling moisture and humidity, regulating temperature, and controlling air pressure changes. The building envelope forms a complicated but integral entity of a building and yet surprisingly, it is frequently the most neglected. By serving these different functions, the envelope also affects ventilation and energy use within the building. The building envelope generally influences the heat exchange between the building and its environment and regulates the penetration of solar energy into the buildings as well as humidity exchange. Moreover, due to the varied and sometimes competing functions associated with the building envelope, an integrated, synergistic approach would be the most appropriate that considers all phases of the facility life cycle. Furthermore, to function efficiently the envelope's main components must be properly designed, constructed, and maintained and all the elements of the envelope should interact in a systematic manner to affect the flow of heat, air, moisture, and sound into or out of the building. This is particularly important since it is estimated that energy losses through the building's exterior walls, floors, roof, windows, and doors account for 10–25% of the energy used by most buildings, depending on the outdoor conditions and construction of the building elements. The better the building envelope's overall performance; the better will be the health, comfort, and productivity of the occupants; and the lower the utility and maintenance bills. The two chief parameters that govern energy losses are the difference in temperature between the indoor and outdoor environment and the envelope's ability to resist heating transfer due to conduction, convection, infiltration, and solar radiation absorption.

There are numerous envelope systems currently in use, each consisting of multiple components and complex technologies. These components need to be properly detailed and maintained for an envelope to operate at maximum efficiency. By addressing the issues of energy efficiency, moisture infiltration, aesthetics, and occupant comfort, etc., the building envelope elements and component systems can enhance design opportunities and minimize potential risk. Using a “sustainable” approach to building design and construction supports an increased commitment to environmental stewardship and conservation, resulting in an optimal balance of cost, environmental, societal, and human benefits while achieving the goals and objectives of the proposed facility.

The condition of the building envelope is therefore vitally important since failures can result in serious safety and health problems, as well as potential structural damage. For these reasons, it is prudent to retain a licensed engineer or architect with sufficient experience in building envelope issues

and that is capable of conducting a proper investigation and as well as prepare drawings and specifications, which may be needed for repair. Typically, applying a holistic approach to the investigation, i.e., viewing the entire building envelope (i.e., foundations, roofs, and walls, etc.), the building's structural and mechanical systems, is often the best way to identify the real cause of the problem. Also, when a problem is encountered, a hands-on, close-up inspection (not just binocular inspection) is imperative to achieving a correct diagnosis. It is important not to forget that what works for one building may not work for another.

Under guidance from the Federal Envelope Advisory Committee has developed a comprehensive design guide for exterior envelope design and construction for both institutional and office buildings. The Envelope Design Guide (EDG) is continually being improved and updated through the Building Enclosure Councils (BECs). Additionally, the National Institute of Building Sciences (NIBS), under contract from six federal agencies: the Army Corps of Engineers, the Naval Facilities Engineering Command (NAVFAC), the Air Force, the General Services Administration (GSA), the Department of Energy (DOE), and the Federal Emergency Management Agency has developed comprehensive federal guidelines for exterior envelope design and construction for institutional/office buildings. The NIBS Design Guide is intended to provide comprehensive guidance on the design and construction of high-quality, long-lasting enclosures for offices and other public buildings. But although intended to significantly improve the performance of building envelopes within the public sector, it is expected that the guide will also provide a great resource for architects and building owners within the private sector as well.

The building envelope's prime functions are to provide shelter, security, solar and thermal control, moisture control, IAQ control, access to daylight, views to outside, fire resistance, acoustics, cost-effectiveness, and aesthetics. And having a well-insulated building envelope is crucial to creating an environmentally sound building. The reduction of heat transfer through the envelope will help minimize energy used to maintain the interior climate, while at the same time help reduce both utility bills and the environmental costs of fossil fuel use.

9.2.1 Exterior Wall Systems

One approach to characterizing building wall systems is based on the function they serve. Based on this, they can be divided into three broad categories. These are (1) Veneer system, (2) Structural/Load Bearing wall system, and (3) Nonload bearing wall system. But whatever the category,

it is important to comply with local and national code requirements. In this respect, it may be helpful to employ an organization like UL (a global independent safety science company), which provides certification for exterior wall systems and components, thus providing architects and building contractors the evidence needed to demonstrate compliance to code requirements for a wide range of properties including fire propagation resistance to NFPA 285, water penetration resistance to ASTM E331, and air leakage resistance to ASTM E2357.

Exterior building wall systems can also be divided into various categories based on materials employed in the wall system as shown below:

Masonry Wall Systems

Masonry has been used in building construction from prehistoric times to the present day. Today masonry wall systems are employed to form durable cladding systems with various aesthetic effects. In addition to being used for exterior cladding, masonry walls can serve as a portion of the structural framing for the building. Masonry walls are also known for their increased fire resistance of the wall system or structural elements. Masonry is usually constructed on site where the units are laid in mortar to various heights; the strength of the assembly is normally achieved during curing of the mortar. Masonry can also form structural elements (typically bearing walls, columns, or pilasters) and/or the finished cladding system. The Masonry Institute of Washington has recently released a new Masonry Systems Guide Northwest Edition for 2016. This Masonry Systems Guide provides a standardized systems guide of best practices for masonry wall systems design and construction and is an excellent information resource on masonry systems.

Stone Wall Systems

Most thin stone wall systems used for exterior building envelopes take the form of stone panels ranging in thickness from 3/4 to 2 inches. These panels are typically fabricated from granite, while marble, limestone, travertine, and sandstone are also used but to a lesser extent. Overall panel dimensions can vary significantly depending on the panel's design and its function, and also depending on the strength of the stone used in the panel and architectural affect desired. However, maximum panel dimensions are usually in the 3–4 ft range but not more than approximately 6 ft. Each panel typically needs to be independently supported to the building structure or backup system using an assemblage of metal components and anchors. Likewise, the joints at the perimeter of each panel, which are usually 3/8 inch in width

are filled with sealant. A drainage cavity can typically be found behind the stone panels to collect and divert to the exterior water that managed to penetrate through the joints (Fig. 9.1).

Concrete

Concrete is the most widely used building material in the world, for everything from high-rise buildings to bridges to roads and everything in between;

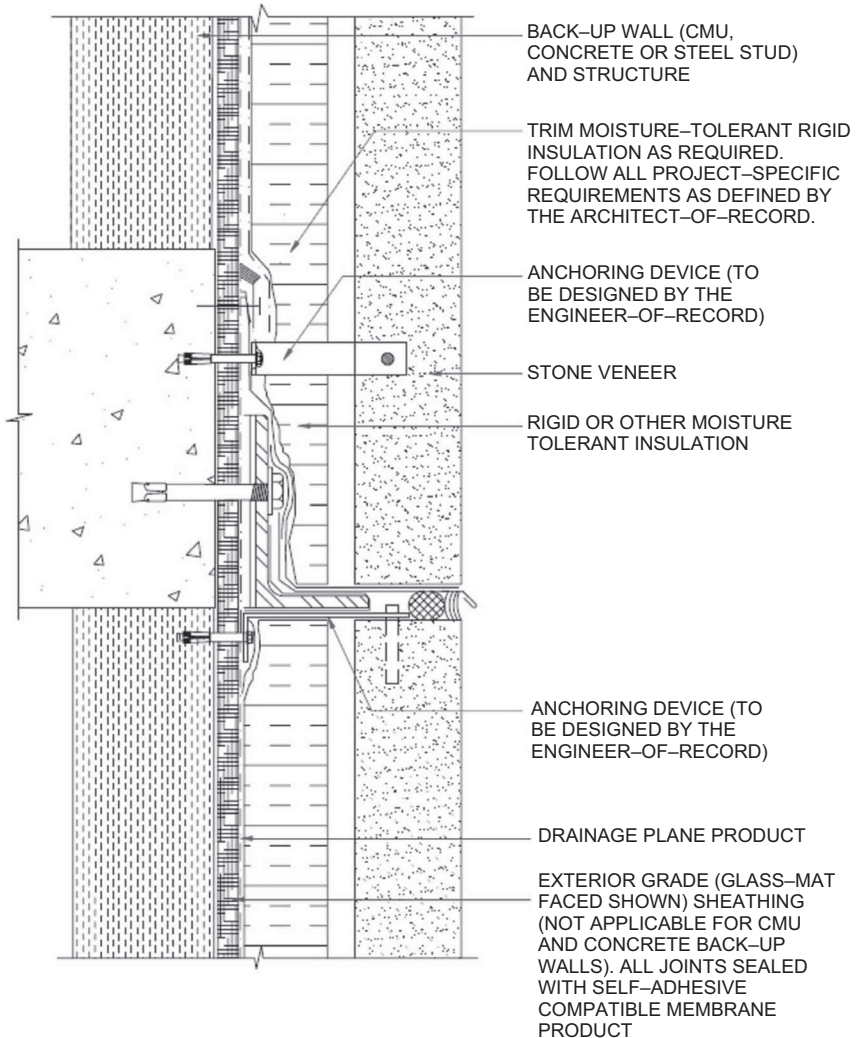

Figure 9.1 Detail of stone veneer with through-wall flashing; not intended for use with an actual project. *Courtesy, Whole Building Design Guide.*

it is also one of the most durable. Yet for all the seeming permanence of concrete, it has come under attack from both natural and man-made forces since the time it was first formed and poured. The relative rate of degradation resulting from these assaults depends on a wide variety of factors of which only some are controllable. Concrete is a man-made material and a composite construction material, composed of cement and other cementitious materials such as fly ash and slag cement, aggregate (generally a coarse aggregate made of gravel or crushed rocks such as limestone, or granite, plus a fine aggregate such as sand), chemical admixtures, and water. Exterior concrete can be produced to provide a durable surface. Concrete unsuited for exterior applications can scale when exposed. Concrete is discussed in greater detail in [Chapter 6](#) (Green Building Materials and Products).

Exterior Insulation and Finish System

Exterior Insulation Finish System, also known by the acronym EIFS, is an exterior wall covering that the Whole Building Design Guide (WBDG) describes as “an exterior wall cladding that utilizes rigid insulation boards on the exterior of the wall sheathing with a plaster appearance exterior skin.” The International Building Code and ASTM International define EIFS as a nonload bearing, exterior wall cladding system consisting of an insulation board attached either adhesively or mechanically, or both, to the substrate; an integrally reinforced base coat; and a textured protective finish coat. But some concern has arisen with EIFS that if not properly installed or maintained, moisture can penetrate through openings in the cladding and become trapped.

EIFS were first introduced in the United States in the late 1960s, and were first used on commercial buildings, and later on homes. Over the years, variations of the EIFS system have been developed. In the case of a wood-framed structure, the trapped water is absorbed by the wood and wood rot, decay, fungus, and insect infestations become problems, none of which are externally visible. Note that all EIFS are proprietary systems and the components of the system should not be modified beyond the limits stated in the manufacturer’s literature.

According to the WBDG, “EIFS is available in two basic types: a barrier wall system or a wall drainage system. Barrier EIFS wall systems rely primarily on the base coat portion of the exterior skin to resist water penetration. Therefore, all other components of the exterior wall must either be barrier type systems or be properly sealed and flashed to prevent water from migrating behind the EIFS and into the underlying walls or interiors. Wall drainage EIFS systems are similar to cavity walls; they are installed over

a weather barrier behind the insulation that acts as a secondary drainage plane. The weather barrier must be properly flashed and coordinated with all other portions of the exterior wall to prevent water from migrating into the underlying walls or interiors.”

It should be mentioned that EIFS today are one of the most tested and well-researched cladding systems in the construction industry. The Oak Ridge National Laboratory and supported by the Department of Energy has validated that EIFS are the “best performing cladding” in relation to thermal and moisture control when compared to brick, stucco, and cementitious fiberboard siding. Moreover, EIFS is in full compliance with the latest building codes, which emphasize energy conservation through the use of continuous insulation and a continuous air barrier. Both these components are incorporated into today’s EIFS products to provide maximum energy savings, reduced environmental impact over the life of the structure, and enhanced IAQ.

Curtain Walls

It is an outer covering of a building in which the outer walls are non-structural but are attached to the building structure and used to keep out the weather. Because the curtain wall is nonstructural it can be made of a lightweight material (such as aluminum-framed walls containing in-fills of glass, metal panels, or thin stone), reducing construction costs. The use of glass as the curtain wall has the advantage of allowing natural light to penetrate deeper within the building. Of note, the curtain wall facade does not carry any dead load weight from the building other than its own dead load weight. In addition, a curtain wall is designed to resist air and water infiltration, resist sway induced by wind and seismic forces acting on the building, and its own dead load weight forces.

Curtain walls generally fall into two basic categories that are based on their method of fabrication and installation. These are as follows: the *unitized or modular systems* (Fig. 9.2a and b) and the *stick systems* (Fig. 9.3a and b). In the stick system, the curtain wall frame (mullions) and glazing panels are installed and connected together piece by piece. In the unitized system, the curtain wall is composed of large units that are assembled and glazed in the factory, shipped to the site, and erected on the building.

Siding/Cladding/Weatherboard

Siding (also known as cladding and weatherboard) is an exterior finish material that is installed over the wall framing or building support

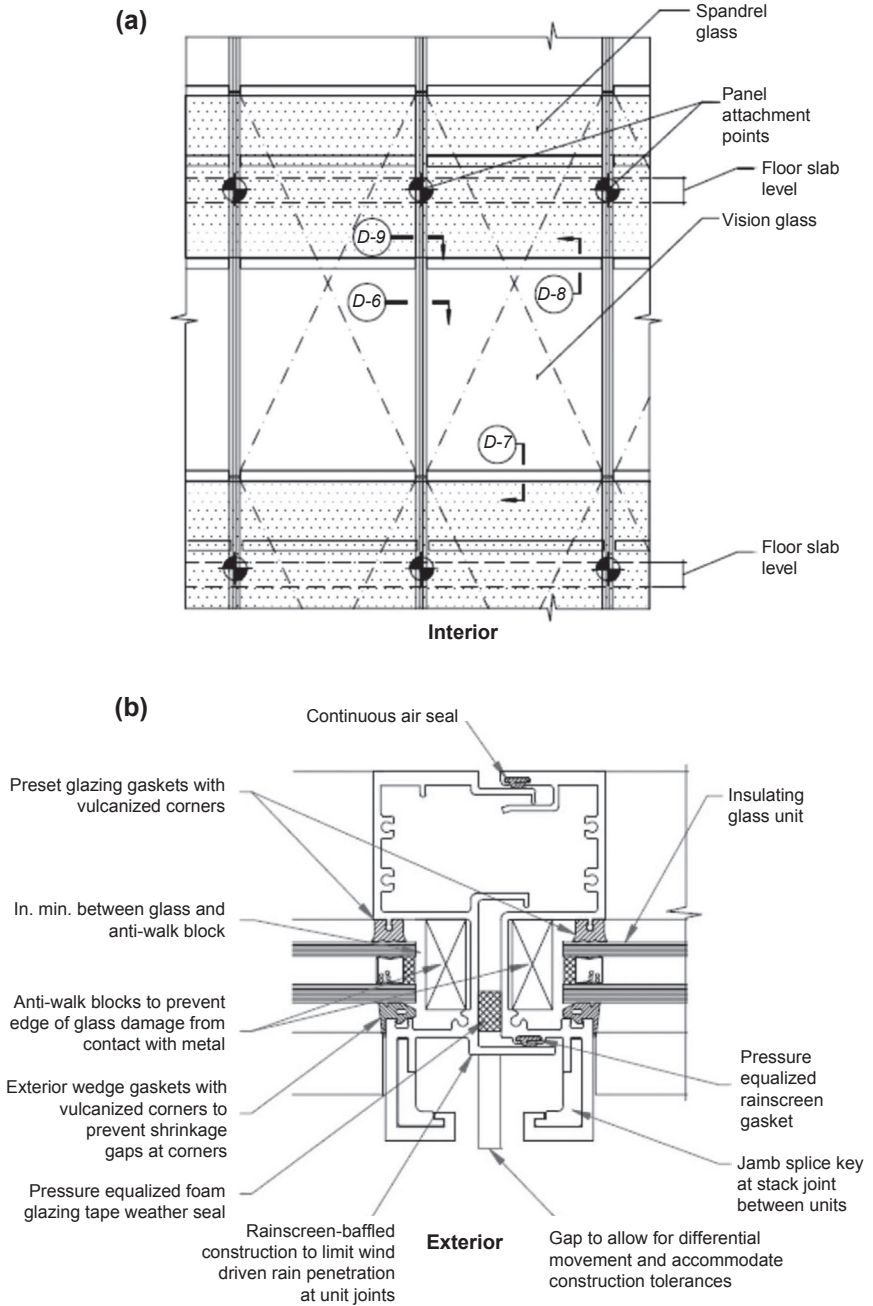

Figure 9.2 (a) Typical Elevation Unitized Curtain Wall System, (b) Vision Glass Jamb Detail—Unitized Curtain Wall System. Courtesy: WBDG.

structure. Siding's main functions are to improve the exterior appearance of the building and also to help keep external elements out. Although siding itself may not be water or wind resistant, if combined with other waterproofing elements like building wrap and insulation, siding systems can help complete the exterior walls of a building. Siding comes in many forms and materials, which are generally chosen based on the design and aesthetics of the building (for further details, see [Chapter 6: Green Building Materials and Products](#)).

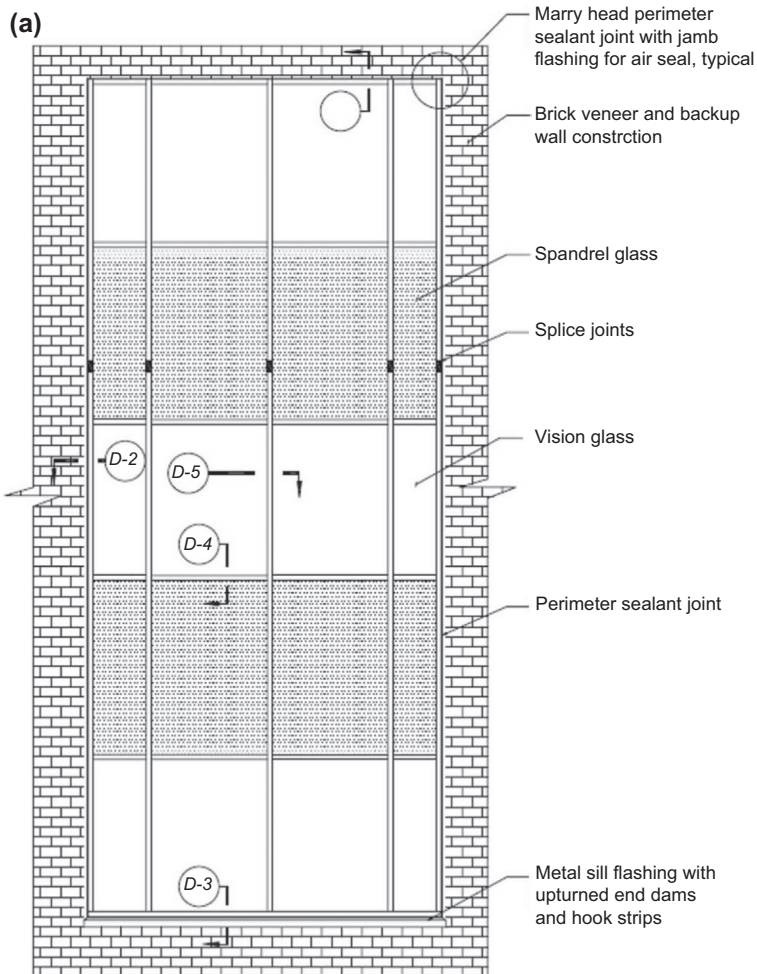

Figure 9.3 (a) Typical Elevation Stick-Built Curtain Wall System, (b) Curtain Wall Head Detail—Stick-Built System. *Courtesy: WBDG.*

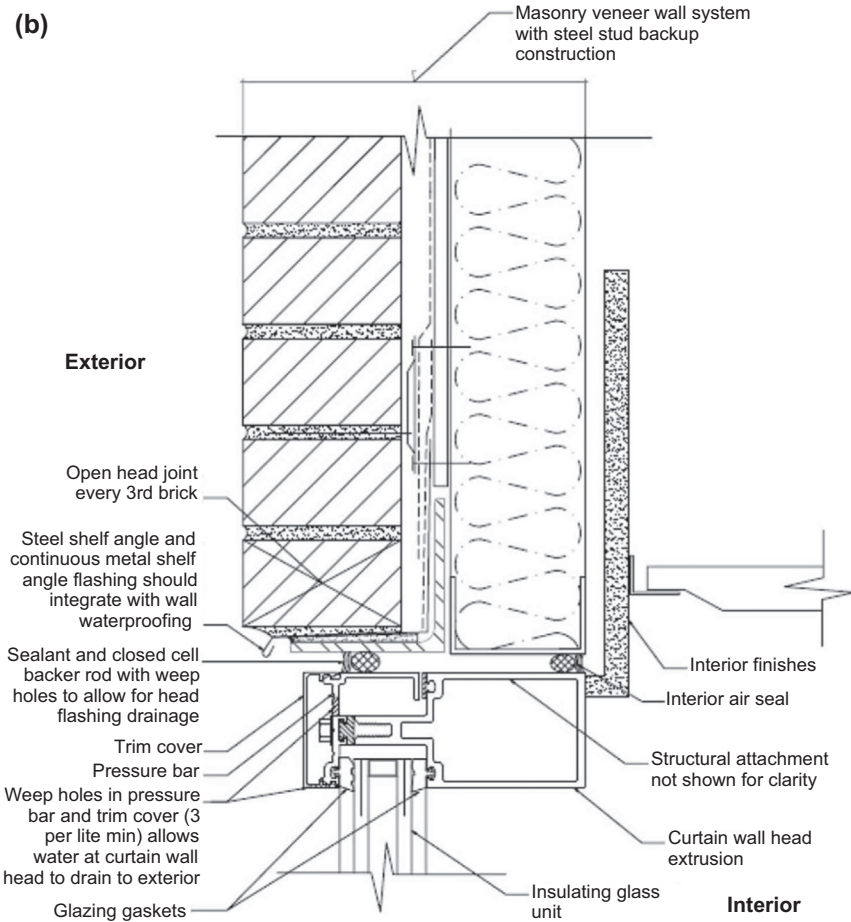

Figure 9.3 Cont'd

Windows, Exterior Doors, and Skylights

These elements are basically holes in the walls and roof that admit light and people. Doors and windows are important elements of the exterior closure system because they provide visual and physical access between the exterior and interior environments and can affect lighting costs by taking maximum advantage of natural daylight. The design and installation of these penetrations are the areas of most frequent water and air infiltration into buildings, which is why energy-efficient doors, windows, and skylights are helpful to reduce heat flow between indoors and outdoors. For this reason, special weatherproofing precautions are often installed around the perimeter of the door (Fig. 9.4). It is estimated that having optimum window and door placement with energy efficient glazing can reduce energy consumption by 10–40%.

9.2.2 Weatherproofing

Leakage problems in construction have become the number one cause of lawsuits, which is perhaps why in today's competitive construction market, building owners and investors seek a structure that is aesthetically pleasing and remains leak free for as many years as possible. Moisture intrusion into buildings causes billions of dollars in property damage annually. Furthermore, moisture in buildings is the number one cause of mold and mildew growth and should be removed before it contaminates the entire buildings and occupants (Fig. 9.5). One of the critical elements in maintaining a weatherproof envelope is the performance of joints in the buildings. All buildings require joints and how you seal these joints is an important factor in determining the overall performance and durability of the envelope. But moisture can intrude into a building in a

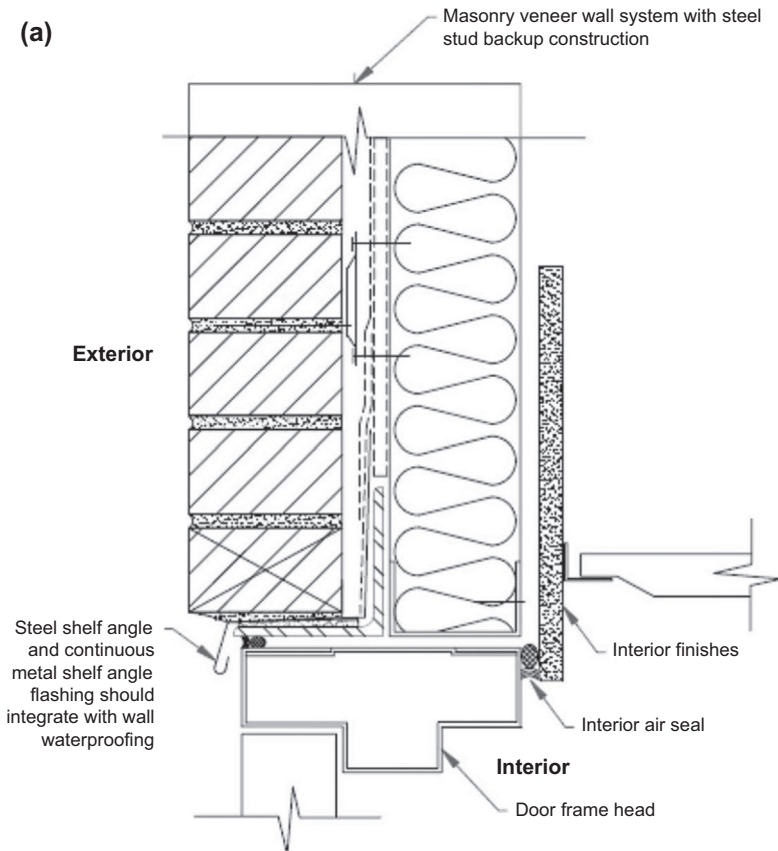

Figure 9.4 Section at door head detail.

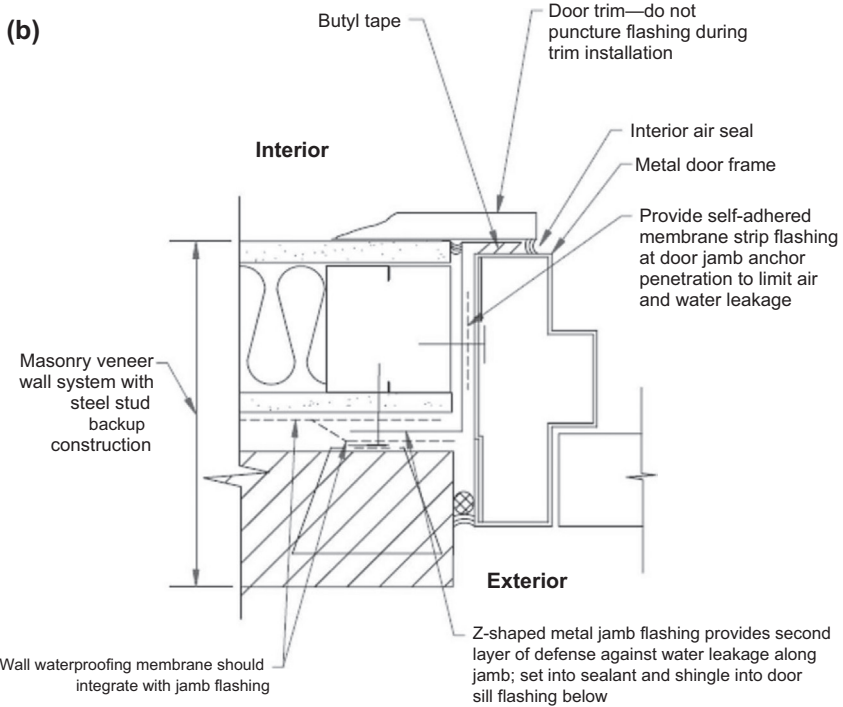

Figure 9.4 Cont'd



Figure 9.5 Photo showing effects of water penetration contributing to mold growth.

number of ways, whether from improperly designed and/or constructed vapor barriers in walls, roofs and floors or through leaks in walls, floors, roofs, windows, and doors caused by improper design, construction, and maintenance.



9.3 INTELLIGENT ENERGY MANAGEMENT SYSTEMS

Over the past decade, we have witnessed the demand for energy growing faster than supply, meaning that for any level of sustainability to be achieved, a more efficient generation, delivery, and consumption of energy is essential, i.e., the clear requisite for Intelligent Energy Management Systems. Indeed, not only can intelligent energy management technologies provide immediate solutions, but correctly implemented, these new intelligent technologies can cut energy use, spending, and emissions, as well as provide a solid foundation to build tomorrow's smarter energy infrastructure. Building automation basically consists of a programmed, computerized, "intelligent" network of electronic devices that monitor and control the mechanical and lighting systems in a building, and as more and more buildings are incorporating central communications systems, the Computer Integrated Building has not only become a reality but has become an integral part of mainstream America and one of the landmarks of today's society. The primary intent being to create an intelligent sustainable building that can reduce energy and maintenance costs. In addition, increasing consumer demand for clean renewable energy and the deregulation of the utilities industry have spurred growth in green power—solar, wind, geothermal steam, biomass, and small-scale hydroelectric sources of power. Small commercial solar power plants are beginning to emerge and have started to serve some energy markets.

9.3.1 Building Automation and Intelligent Buildings

Today over half the world's population lives in cities, and over the next 20 years, it is estimated that nearly 10% more will move to cities. This rising demand for urbanization has encouraged greater efficiency. Thus the concept of intelligent buildings, which was introduced in the United States in the early 1980s. With this approach, intelligent buildings employ high-technology electronics extensively to achieve desired results, which basically consisted of integrating four primary groups (energy efficiency, life safety systems, telecommunications systems, and workplace automation) into a single computerized system.

There have been various definitions of intelligent buildings and sustainability. The definition proposed by the Intelligent Building Institute is "an intelligent building is one that provides a productive and cost-effective environment through optimization of its four basic elements—structure,

systems, services and management—and the interrelationships between them. Intelligent buildings help business owners, property managers and occupants to realize their goals in the areas of cost, comfort, convenience, safety, long-term flexibility and marketability.” Regarding sustainability, the *ASHRAE GreenGuide* defines it as “Providing for the needs of the present without detracting from the ability to fulfill the needs of the future.” An intelligent building, on the other hand, can be said to be one that provides a productive and cost-effective environment through optimization of its basic elements: structure, systems, services and management, and the interrelationships between them. Thomas Hartman, P.E., a building automation expert, on the other hand, believes there are three cardinal elements of an intelligent building. These are as follows:

- 1. The Occupants:** An intelligent building is one that provides easy access; keeps people comfortable, environmentally satisfied, secure; and provides services to keep the occupants productive for their purpose in the building.
- 2. Structure and Systems:** An intelligent building is one that at a bare minimum significantly reduces environmental disruption, degradation, or depletion associated with the building while ensuring a long-term useful functional capacity for the building.
- 3. Advanced Technologies:** An intelligent building is one that because of its climate and/or use is challenged to meet elements 1 and 2 above, and succeeds in meeting those challenges through the use of appropriate advanced technologies.

Many in the engineering field today understand an intelligent building to be a building that incorporates computer programs to coordinate many building subsystems to regulate the interior temperatures HVAC and providing power. The goal is usually to reduce the operating cost of the building while maintaining the desired environment for the occupants (Fig. 9.6). Often people fail to realize that it is really about the use of advanced technologies to dramatically improve the comfort, environment, and performance of its occupants while minimizing the external environmental impact of its structure and systems. The key phrase here is “comfort of its occupants”—which is what it is all about. In the final analysis, intelligent buildings help property owners and developers as well as tenants to achieve their objectives in the areas of comfort, cost, safety, long-term flexibility, and marketability as well as increased productivity.

Although there are numerous commercial-off-the-shelf Building Automation Systems (BAS) now on the market and the majority of facility

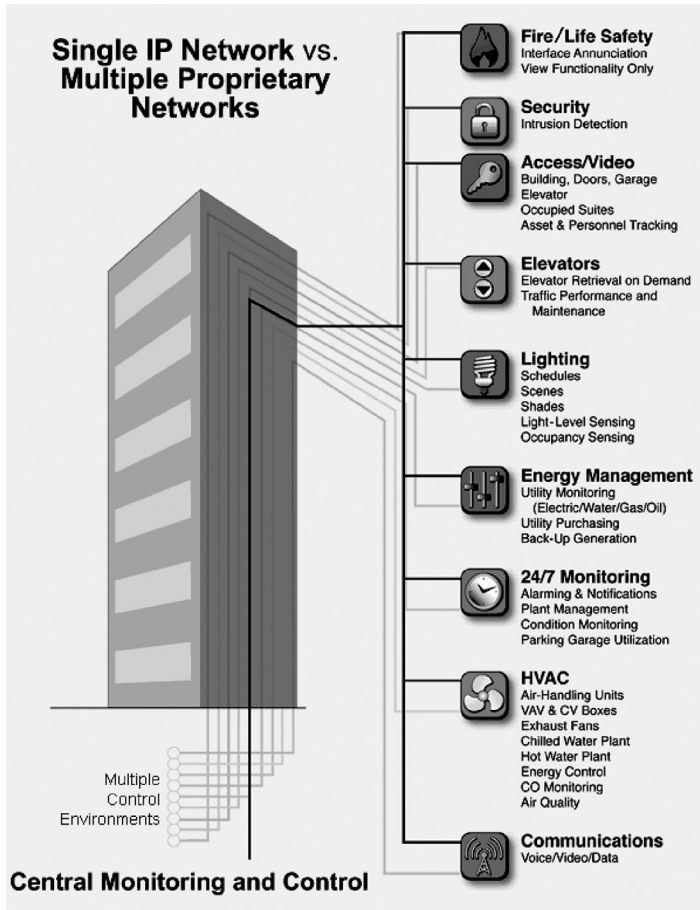

Figure 9.6 An intelligent building is one that can merge building management requirements with IT systems to achieve optimized system performance as well as simplifying general facility operations. In this illustration a single IP network is compared with a multiple proprietary network. *Source: BPG Properties Ltd.*

and building managers recognize the potential value of such systems as a powerful energy saving tool, if it was not for the initial costs involved there would be no hesitation in employing them. As an example, one basic BAS that is readily available saves energy by widening temperature ranges and reducing lighting in unoccupied spaces and reduces costs for electricity by shedding loads when electricity is higher priced. But Bill Lydon, InTech, Chief Editor, airs a degree of caution and says, “It is easy to label a product with the term *commercial off-the-shelf (COTS)*, and lately it is being done more often as a way to lead buyers to believe it should be the only

criteria to select a product. Automation and control professionals should consciously make decisions based on their operational goals.”

In this respect, Kristin Kamm, a senior research associate at E Source notes that some of the most common strategies that BASs employ to cut energy use include:

- **Scheduling:** Scheduling turns equipment on or off depending on time of day, day of the week, day type, or other variables such as outdoor air conditions.
- **Lockouts:** Lockouts ensure that equipment does not turn on unless it is necessary. For example, a chiller and its associated pumps can be locked out according to calendar date, when the outdoor air falls below a certain temperature or when building cooling requirements are below a minimum.
- **Resets:** When equipment operates at greater capacity than necessary to meet building loads, it wastes energy. A BAS can ensure equipment operates at the minimum needed capacity by automatically resetting operating parameters to match current weather conditions. For example, as the outdoor air temperature decreases, the chilled water (CHW) temperature can be reset to a higher value.
- **Diagnostics:** Building operators who use a BAS to monitor information such as temperatures, flows, pressures, and actuator positions may use that data to determine whether equipment is operating incorrectly or inefficiently and to troubleshoot problems. Some systems also use the data to automatically provide maintenance bulletins.

Customized building automation can be complex depending on the needs of the client. As a building owner or operator, you need to have the ability to monitor your building(s) whenever you wish to do so, 24 h a day. With Internet-based systems available, it is now possible to monitor your building from any location that has an Internet connection. Some intelligent buildings now have the capability to detect and report faults in the mechanical and electrical systems, especially critical systems. Many also have the ability to track individual occupants and to adapt building systems to the individual’s wants and needs (e.g., setting a room’s temperature and lighting levels automatically when a homeowner enters), as well as anticipating forecasted weather, utility costs, or electrical demand. There are other nonenergy uses for automation in a building, such as scheduling preventive maintenance for the building, monitoring security, monitoring rent or consumables charges based on actual usage, and even giving directions within the building.

Some of the typical elements and components that are frequently employed in building automation are described below:

Controller: A controller is one of the key components in a BAS; it is basically a small, specialized computer. One of main advantages of today's controllers is that they allow users to have the benefit of networking and gain real-time access to information from multiple resource segments in a building's network, creating an "Intelligent Building." Controllers come in a variety of sizes and capabilities to control devices that are commonly found in buildings, which is why it is important to understand the numerous applications of these controllers. Their main purpose is to regulate the performance of the various facilities within the building. Traditionally, this includes the following:

- Heating, ventilation, and air conditioning systems
- Mechanical systems
- Electrical systems
- Plumbing systems
- Lighting systems
- Security Systems
- Surveillance Systems.

Some BASs can even be designed to control other systems such as the fire alarm system and the building's elevators.

Occupancy sensors: These devices were originally designed for use with security systems, occupancy sensors have been refined and enhanced to control lighting and HVAC in both commercial and residential spaces. There are different types of occupancy sensors such as infrared, ultrasonic, and dual tech sensors that are designed to meet a wide range of applications. Occupancy is usually based on time of day schedules, but override is possible through different means. Some buildings can sense occupancy in their internal spaces by an override switch or sensor. Sensors can be either ceiling mounted or wall mounted, depending on the type and application (Fig. 9.7).

Lighting: Studies show that most of today's buildings are overlit because light levels are set higher than required for the space; spaces are often lit even when they are unoccupied. This wastes energy, creates discomfort, and reduces productivity. But with today's BASs, lighting can be turned on and off depending on the time of day, or the occupancy sensors and timers. There are many different control systems in existence, including time-based control and optimizer parameter-based where a level of illuminance



Figure 9.7 A multicriteria intelligent sensor, Acclimate that incorporates both thermal and photoelectric technologies that interact to maximize detection. Acclimate is a fire sensor with an onboard microprocessor with advanced software that makes adjustments to reduce false alarms. *Source: System Sensor.*

or particular use of lighting is required. One typical example is to turn the lights in a space on for an half hour since the last motion was sensed. A photocell placed outside a building can sense darkness, and the time of day, and modulate lights in outer offices and the parking lot. This is discussed in greater detail in the Lighting section.

Air handlers: Less temperature change is required with most air handlers because they typically mix the return and outside air. Analog or digital temperature sensors may be placed in the space or room, the return and supply air ducts, and sometimes the external air. Actuators are placed on the hot and CHW valves, the outside air and return air dampers. This in turn can save money by using less chilled or heated water [not all Air Handling Units (AHUs) use chilled/hot water circuits]. Some external air needs to be introduced to keep the building's air quality healthy. The supply fan (and return if applicable) is started and stopped based on either time of day, temperatures, building pressures, or a combination of all three.

Constant Volume Air-Handling Unit (CAV): This is a less efficient type of air handler because the fans lack variable speed controls. Instead, CAVs open and close dampers and water supply valves to maintain temperatures in the building's spaces. The CAVs heat or cool the spaces by opening or closing chilled or hot water valves that feed their internal heat exchangers. Generally, one CAV serves several spaces but in larger buildings may incorporate many CAVs.

Variable Volume Air-Handling Unit (VAV): The VAV is a more efficient unit than the CAV, and unlike constant air volume (CAV) systems, that supply a constant airflow at a variable temperature, VAV systems vary the airflow at a

constant temperature. The primary advantages of VAV systems over constant volume systems include more precise temperature control, lower energy consumption by system fans, reduced compressor wear, less fan noise, and further passive dehumidification. This system essentially brings outside air and return air to the AHU, where the temperature and humidity of the incoming air can be controlled. VAVs supply pressurized air to VAV boxes, usually one box per room or area. A VAV air handler can change the pressure to the VAV boxes by changing the speed of a fan or blower with a variable frequency drive or (less efficiently) by moving inlet guide vanes to a fixed-speed fan. The amount of air is determined by the needs of the spaces served by the VAV boxes. Some VAV boxes also have hot water valves and an internal heat exchanger. The valves for hot and cold water are opened or closed based on the heat demand for the spaces it is supplying. A minimum and maximum CFM must be set on VAV boxes to assure adequate ventilation and proper air balance. The main AHU components are the supply fan, heating coil, cooling coil, filter, and humidity control equipment.

VAV Hybrid Systems: In many large systems or systems that have undergone renovation, it is not unusual to find a combination of constant volume and variable volume zones in a single air handler. The hybrid system is basically a variation between VAV and CAV systems. Health-care, laboratory, and process applications are the most prone to this configuration. In this system the interior zones operate as in a VAV system but the outer zones differ in that the heating is supplied by a heating fan in a central location usually with a heating coil fed by the building boiler. The heated air is ducted to the exterior dual duct mixing boxes and dampers controlled by the zone thermostat calling for either cooled or heated air as necessary.

Central plant: Central plant equipment can offer substantial opportunities for generating energy savings, both in the plant and in the connected buildings. It can also improve the comfort conditions of building occupants. However, the main function of a central plant is to supply the AHUs with water. It may supply a CHW system, hot water system, and a condenser water system, as well as transformers and an auxiliary power unit for emergency power. If well managed, these can often help each other. For example, some plants generate electric power at periods with peak demand, using a gas turbine, and then use the turbine's hot exhaust to heat water or power an absorptive chiller.

Chilled water system: This is normally used to cool a building's air and equipment. CHW systems usually incorporate chiller(s) and pumps. Analog temperature sensors are used to measure the CHW supply and return lines. The chiller(s) are sequenced on and off to ensure that the water supply is chilled. The

efficiency of the CHW systems is its ability to integrate and directly interface with the complete BAS via various communications protocols.

Condenser water system: Cooled condenser water is supplied to the chillers through the use of cooling tower(s) and pumps. And in order to ensure that the condenser water supply to the chillers is constant, speed drives are commonly employed on the cooling tower fans to control temperature. Proper cooling tower temperature assures the proper refrigerant head pressure in the chiller. Analog temperature sensors measure the condenser water supply and return lines. The cooling tower set point used depends upon the refrigerant being used.

Hot water system: The hot water system supplies heat to the building's AHUs or VAV boxes. The hot water system will have a boiler(s) and pumps. Analog temperature sensors are placed in the hot water supply and return lines. Some type of mixing valve is typically incorporated to control the heating water loop temperature. The boiler(s) and pumps are sequenced on and off to maintain constant supply.

Alarms and security: All modern BASs incorporate some form of alarm capabilities. If an alarm is detected, it can be programmed to notify someone, since it does little good to detect a potentially hazardous or costly situation if no one is there who can resolve the problem when notified. Notification can be implemented via a computer (email or text message), pager, cellular phone, or audible alarm. Security systems can also be interlocked to a BAS. If occupancy sensors are present, they can also be used as burglar alarms. For insurance and liability purposes, all systems typically keep logs of who was notified, as well as when and how. This is discussed in greater detail in [Section 9.8](#) of this chapter.

There are a large number of propriety http://en.wikipedia.org/w/index.php?title=Building_automation&action=edit§ion=15 protocols and industry standards on the market today, including ASHRAE, BACnet, DALI, DSI, Dynet, Energy Star, KNX standard, LonTalk, and ZigBee. The latest details of these systems can be found by researching the Internet as they are outside our scope.



9.4 MECHANICAL SYSTEMS: AIR CONDITIONING, HEATING, AND VENTILATION

Most tenants living today in urban American cities now take for granted that the buildings they live and work in will have appropriate

mechanical HVAC systems in place. It is understood that these systems are designed to provide air at comfortable temperature and humidity levels, free of harmful concentrations of air pollutants (Fig. 9.8). Moreover, the technological advances and continuous development of air conditioning systems have brought about fundamental changes in the way we design projects because it has allowed investors to build larger, higher, and more efficient buildings than was previously possible. But even though buildings today are being designed with increasingly sophisticated energy management and control systems for monitoring and controlling the conditions of a building's interior space, we nevertheless frequently discover that a building's HVAC equipment routinely fails to satisfy the performance expectations of its designers and owners; yet these failures often going unnoticed for extended periods of time.

The introduction of these new technologies and developments in computers and electronics equipment has made it possible to create HVAC systems that are smarter, smaller, and more efficient. These advancements

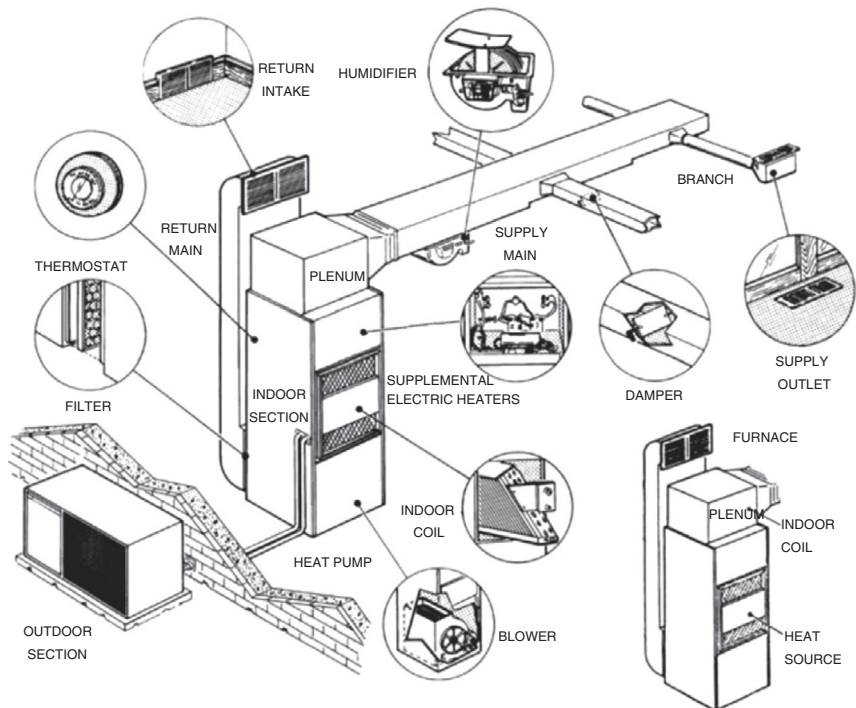

Figure 9.8 Diagram illustrating the basics of HVAC (heating, ventilating, and air conditioning) systems. *Source: Southface Energy Institute.*

have reshaped how the systems are installed, how they are maintained, and how they operate. Among the more important developments in HVAC equipment design in recent years include the introduction of VAV, which basically involves a technique for controlling the capacity of a HVAC system. This means that with these systems, persons who have conditioned air circulating in, on, or around them can control the temperature in their own particular personal space. For example, if two individuals are on the same system and one seeks to increase the temperature, the system can heat that person's space and cool the other. Another advantage is that VAV can change the volume of air delivered to the space and also damper off a space that is not used or occupied, thereby increasing efficiency. The fan capacity control, especially with modern electronic variable speed drives, reduces the energy consumed by fans which can be a substantial part of the total cooling energy requirements of a building. Also, to attain part load cooling capacity, dehumidification with VAV systems is greater than it is with constant volume systems, which modulate the discharge air temperature.

Recent estimates indicate that buildings in the United States annually consume about 42% of America's energy and 68% of its electricity, of which HVAC systems consume a significant percentage. Energy sources that provide power to an HVAC system are usually gas, solid fuels, oil, or electricity, and the conducting medium usually being water, steam, or gas. The heating and cooling source equipment comprises of components that use the energy source to heat or cool the conducting medium. The heating and cooling units (such as air conditioners and AHUs) are the components of the system that are instrumental in modifying the air temperatures in the interior spaces. The assessment of the HVAC system is one of the main components of a general baseline evaluation.

Researchers and others have known for decades that physical comfort is critical to work effectiveness, satisfaction, and physical and mental well-being, and occupants may even be driven to distraction trying to adjust the comfort in their space. As discussed in [Chapter 7](#), Indoor Environmental Quality, we know that uncomfortable conditions in the workplace such as noise, inadequate lighting, uncomfortable temperature, high humidity, ergonomics, and other physiological stressors invariably restrict the ability of people to function to their full capacity, leading in many cases to lower job satisfaction and increases in building-related illness symptoms. And since humans generally spend most of their time indoors, the health, well-being,

and comfort inside buildings are crucial issues because they help us breathe easier and focus our attention better.

9.4.1 Refrigerants: Hydrochlorofluorocarbons and Chlorofluorocarbons

A refrigerant is a substance, usually a fluid (chemical compounds), that is used in a refrigeration cycle to cool a space. Refrigerants capture heat and then release it to another space by using the thermodynamic phenomena of phase changes, in which a fluid changes to a gas or vice versa in the refrigeration cycle. The two refrigerant families most often used in air conditioning systems are **hydrochlorofluorocarbons (HCFCs) and CFCs**. Refrigerants are used primarily in refrigerators/freezers, air conditioning, and fire suppression systems. Mike Opitz, Certification Manager, LEED for Existing Buildings (USGBC) says, “Chemical refrigerants are the heart of a large majority of building HVAC and refrigeration equipment. These manufactured fluids provide enormous benefits to society, but in recent decades have been found to have harmful consequences when released to the atmosphere: all refrigerants in common use until the 1990s caused significant damage to the protective ozone layer in the earth’s upper atmosphere, and most also enhanced the greenhouse effect, leading to accelerated global warming.” For example, in the EA Credit 4 (Enhanced Refrigerant Management) for NC, Schools, and CS, points can be earned by either not using refrigerants (Option 1) or by selecting environmentally friendly refrigerants and HVAC&R that minimize or eliminate the emission of compounds that contribute to ozone depletion and global warming (Option 2).

On September 21, 2007, these and other issues were addressed when parties to the Montreal Protocol, including the United States, overwhelmingly agreed to accelerate the phase out of HCFCs to protect the ozone and combat climate change with adjustments beginning in 2010 to production and consumption allowances for developed and developing countries. This refrigerant phase out of CFCs (production of CFCs ceased in 1995) and HCFCs will have a significant impact on proposed real estate purchases that still utilize this equipment. The 2007 Montreal Protocol definitely energized the green building movement and equipment manufacturers to undergo changes in the types of refrigerants used in certain equipment because of general environmental concerns and to seek suitable more environmental alternatives. It is no longer a question of whether facilities managers will upgrade their HVAC and other equipment, but when and how. This means

that owners and administrators will need to take the long-term view when making decisions that can impact their capital investments.

In accordance with the Montreal Protocol, the Environmental Protection Agency (EPA) is now obligated to phase out HCFC refrigerants used in heat pump and air conditioning systems because of their impact on ozone depletion. CFC refrigerants manufacture has been banned in the United States since 1995. To date, the main alternatives are HFCs and HFC blends, although there are several potential non-HFC alternatives as well. Dupont has produced a complete family of easy-to-use, nonozone-depleting HFC retrofit refrigerants for CFC and HCFC equipment. But while HFCs may be suitable as short to medium-term replacements, they may not be suitable for long-term use due to their high GWP and their impact on the environment.

In some categories of the LEED Rating System, Minimum Energy Performance and Fundamental Refrigerant Management are included as prerequisites, the intent is to establish a minimum level of energy efficiency for the building system and reduce ozone depletion potential, GWP, and support early compliance with EPA Montreal Protocol. The LEED Requirements being to have zero use of CFC-based refrigerants in new HVAC&R systems. When reusing existing base building HVAC, a comprehensive CFC phase-out conversion must be conducted prior to project completion. Also, various categories of the U.S. Green Building Council LEED programs award one credit point for using nonozone depleting, HFC refrigerants.

9.4.2 Types of Heating, Ventilating, and Air Conditioning Systems

HVAC systems account for an estimated 39% of the energy currently used in commercial buildings in the United States. Therefore, most business or government agency have the potential to realize significant savings by improving their control of HVAC operations and improving the efficiency of the system they use. There are basically two approaches to conditioning a room or building. The first method is using a radiant system, the second is using a forced air system. Radiant Systems usually involve running hot or CHW through pipes that loop around the structure and radiate into the conditioned space via a floor surface or radiator pipe. Forced air systems use a fan to push air through a duct system where it is conditioned by a coil on a furnace or air handler before being returned to the space. And while there are a wide variety of HVAC systems in use in today's real estate, no system is right for every application. In order to service the specific needs, there are

a number of different types of HVAC systems available (e.g., single zone/multiple zone, constant volume/variable air volume). The most common classification of HVAC systems is by the carrying mediums used to heat or cool a building. The two main transfer mediums for this purpose are air and water, which take them to emitters. On smaller projects, electricity is often used for heating although some systems now use a combination of transfer media. HVAC systems range in complexity from stand-alone units that serve individual rooms or zones to large centrally controlled systems serving multiple zones in a building or complex.

9.4.3 Heating Systems

As previously mentioned, HVAC is an integral component of a building's design and construction. Likewise, the type of heating system chosen can have a major impact on a project's construction costs, operating expenses, and carbon footprint. Heating buildings, whether commercial or residential is important to keep employees and tenants comfortable. Today, there are a wide variety of different heating systems to choose from, varying in their costs and benefits. The three basic components of heating systems used today to regulate temperature for commercial and residential buildings are as follows: the fuel source, the energy conversion plant, and the energy distribution system. Heating systems can be either central or local. The most commonly used setup is the central heating system where the heating is concentrated in a single central location from where it is then circulated for various heating processes and applications. Some of the more common heating systems currently in use include:

Electric Heating

Electric Heating is a process in which electrical energy is converted to heat. Common applications include space heating, water heating, and industrial processes. An electric heater is therefore a device that transforms electrical energy into heat. Electric heaters contain electric resistors, which act as heating element. The practice of using electricity for heating is becoming increasingly popular in both residences and public buildings. Although electric heating generally costs more than energy obtained from combustion of a fuel, the convenience, cleanliness, and reduced space needs of electric heat often justifies its use. Heat can be provided from electric coils or strips used in varying patterns, such as convectors in or on the walls, under windows, or as baseboard radiation in part or all of a room. Heating elements or wires can even be incorporated in ceilings or floors to radiate low-temperature

heat into a space. Also, by the incorporation of a heat pump the overall cost of electric heating can be reduced significantly.

Electric Baseboard Heaters

Baseboard heating is a fairly common heat source and is essentially a zoned heating system (controlled by thermostats located within each room), meaning that heat can be supplied directly where needed. Also, baseboard heating is simple, quiet, and economical to install because it does not require ductwork, thereby making it worth considering for room additions or in older homes, where adding new ducts might not even be a viable option. However, baseboard heating systems can be expensive to run, particularly if they rely strictly on electricity.

Room are heated by using a process called electric resistance. Inside baseboard heaters are electric cables, and it is these that warm the air that passes through it. Electric baseboard heaters are typically installed along the lower part of outside walls to provide perimeter heating. Room air heated by the resistance element rises and is replaced by cooler room air, establishing a continuous convective flow of warm air while in operation. By superior design and proper placement under a window area, the electric baseboard case causes air to flow naturally. And since baseboard heaters have no moving parts, they rarely break down. Simply removing lint and dust helps keeps most baseboard heating systems working without interruption.

Central Heating

A central heating system provides warmth to the whole interior of a building (or portion of a building) from one point to multiple rooms. When combined with other systems in order to control the building climate, the whole system may be an HVAC system. It is most often used in cold climates to heat a building or group of buildings, although most modern commercial buildings including office buildings, high-rise residential, hotels, and shopping malls are today provided with some form of central heat. There are many different types of central heating systems on the market, most of which comprise of a central boiler (which is actually a heat generator because the water is not “boiled,” it peaks at 82–90°C) or furnace to heat water, pipes to distribute the heated water, and heat exchangers or radiators to conduct this heat to the air. In large systems steam or hot water is usually employed to distribute the heat. However, there is no such thing as a standard central heating system, and each project requires the system to be tailored to meet its own requirements; and with advanced controls a correctly programmed central heating system when

optimized will be able to constantly monitor and automatically adjust the system basically on its own. The term “district heating” is generally applied to systems in which a large number of buildings are supplied with steam from central boiler rooms operated by a public utility.

The main difference between central heating local heating is that with central heating, the heat generation occurs in one place, such as a furnace room in a house or a mechanical room in a large building. The most common method to generate heat involves the combustion of fossil fuel in a furnace or boiler. The resultant heat then gets distributed: typically by forced air through ductwork, by water circulating through pipes, or by steam fed through pipes. Increasingly, buildings utilize solar-powered heat sources, in which case the distribution system normally uses water circulation. With most modern systems, a pump is used to circulate the water and ensure an equal supply of heat to all the radiators. The heated water is often fed through another heat exchanger inside a storage cylinder to provide hot running water. Forced air systems send air through ductwork, which can be reused for air conditioning, and the air can be filtered or put through air cleaners. The heating elements (radiators or vents) are ideally located in the coldest part of the room, typically next to the windows. An important characteristic of central heating system is that it provides warmth to the whole interior of a building or portions of a building as required.

Furnace Heating

This consists of a heating system component that is designed to heat air for distribution to various building spaces. Small capacity furnaces that rely on natural convection for heat distribution can be classified as local systems and can usually effectively condition a single space only. However, furnaces equipped with fans to circulate air over greater distances or to several rooms are used for residential and small commercial heating systems and would be found in most central heating systems in use today. Furnaces typically use natural gas, fuel oil, propane, and electricity for the heat source as well as on-site energy collection (solar energy) and heat transfer (heat pumps). Natural gas furnaces are available in condensing and noncondensing models. The cooling can be packaged within the system, or a cooling coil can be added. When direct expansion systems with coils are used, the condenser can be part of the package or remote. The efficiency of new furnaces is measured by the annual fuel utilization efficiency (AFUE), a measure of seasonal performance. Today’s furnaces are designed to be between 78% AFUE and 96% AFUE. Traditional “power combustion” furnaces are 80–82% AFUE. Above

percent AFUE, a furnace is “condensing,” which generally means it recaptures some of the heat wasted in traditional systems by condensing escaping water vapor. Furnaces, both large and small, are usually automatically responsive to remote thermostats that control their operation. Oil-fired or gas-fired furnaces only need the control of burners to regulate heat. Furnaces that use solid fuels, however, require the admission of additional fuel to the system, and the removal of ashes from the stoker or grates is required.

Radiant Heating

This type of heating is increasing in popularity because it is clean, quiet, efficient, dependable, and invisible. Radiant heating system uses pipes that are installed in the building and has a boiler with either oil or water that is heated in order to get heat in the building. And while it is provided in part by radiation in all forms of direct heating, but the term is usually applied to systems in which floors, walls, or ceilings are used as the radiating units. Steam or hot water pipes are placed in the walls or floors during the construction process, and radiant heating systems circulate warm water through continuous loops of tubing. The tubing system transfers the heat into the floor and upward into virtually any surface including carpeting, hardwood, parquet, quarry and ceramic tile, vinyl flooring, or concrete. If electricity is used for heating, the panels containing heating elements are mounted on a wall, baseboard, or the ceiling of the room. Radiant heating provides uniform heat and is both efficient and relatively inexpensive to operate. But while it may lower energy bills the installation itself might be a little costlier. Efficiency is high because radiant heat raises the inside surface temperature, thereby providing comfort at a lower room air temperature than other systems can provide.

Warm Air Heating Systems

Gravity and Forced Air systems are the two basic types of warm air heating systems currently on the market. The gravity system operates by air convection and is based on the principle that when air is heated it expands, becomes lighter, and rises. Cooler air is dense and therefore falls. The difference in air temperature creates the convection or motivation for air movement. The return of a gravity system must be unrestricted and even a filter is considered too restrictive. This is necessary to develop positive convection and better distribution. The furnace consists of a burner compartment (firebox) and a heat exchanger. The heat exchanger is the medium used to transfer heat from the flame to the air, which moves via ducts to the various rooms. Besides being the medium of heat transfer, the heat exchanger keeps

the burned fuels separate from the air. Often the furnace is arranged so the warm air passes over a water pan in the furnace for humidification before circulating through the building. As the air is heated, it passes through the ducts to individual grills or registers in each room (which may be opened or closed to control the temperature) of the upper floors. The chief problem in this type of system lies in obtaining adequate air circulation, i.e., the system may not heat a facility adequately if the warm air ducts are insufficiently large in diameter, and not slanted upward from the furnace, or properly insulated to prevent heat losses.

As with gravity warm air heating systems, the heat exchanger is the medium of heat transfer and separates the burned fuel from the air that moves through the building. Forced-circulation systems typically have a fan or blower placed in the furnace casing, which blows air through an evaporator coil, which cools the air (Fig. 9.9). This cool air is routed throughout the

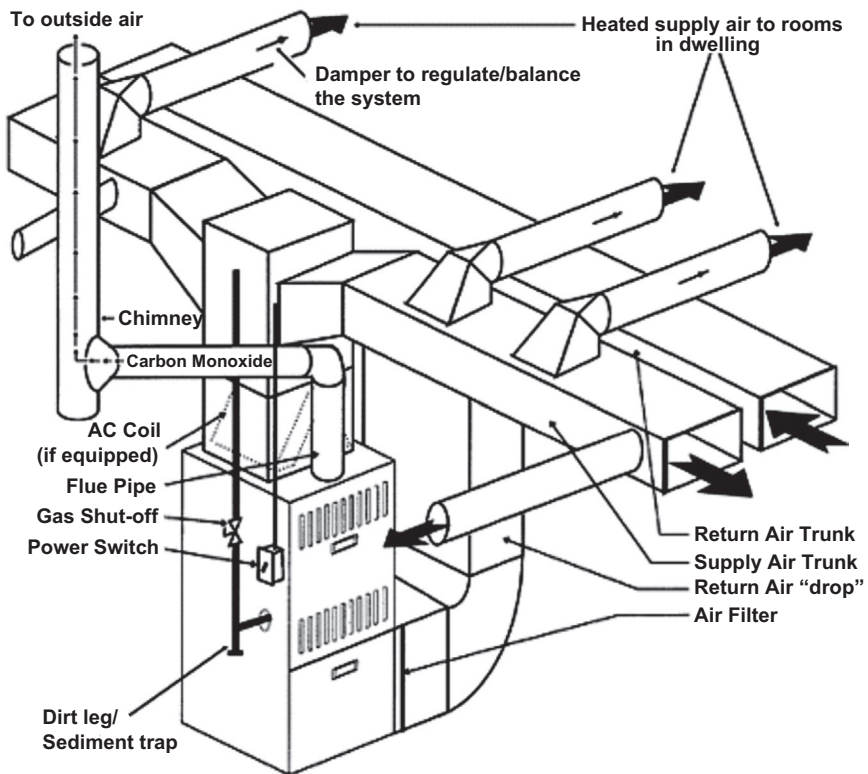

Figure 9.9 Diagram describing how a forced warm air system operates. *Source: warmair.com.inc.*

intended space by means of a series of air ducts thus ensuring the circulation of a large amount of air even under unfavorable conditions. The ability to utilize the same equipment to provide air conditioning throughout the year has given added impetus to the use of forced-circulation warm air systems in residential installations. In addition, when combined with cooling, humidifying, and dehumidifying units, forced-circulation systems may be effectively used for heating and cooling in various types of buildings.

Hot Water Heating Systems

These systems typically have a central boiler, in which water is heated to a temperature of from 140°F to 180°F (60–83°C), and which is then circulated by means of pipes to some type of coil units, such as radiators, located in the various rooms. Circulation of the hot water can be accomplished by pressure and gravity, but forced circulation using a pump is more efficient because it provides flexibility and control. In the rooms, the emitters give out the heat from their surfaces by radiation and convection. The cooled water is then returned to the boiler. In addition, there are combination systems that use ducts for supplying air from the central AHU, and water to heat the air before it is transferred into the conditioned space. Combination boiler heating systems are the most commonly used in central heating systems. Running on mains pressure water eliminates both the need for tanks to be placed in the loft and the need for a hot water cylinder as the water is instantly heated when needed. Hot water circulating systems generally provide convenience and save water but have proven not be cost-effective as well as expending large amounts of energy.

Generally speaking, hot water systems use either a one-pipe or a two-pipe system to circulate the heated water. The one-pipe system uses less pipe than the two-pipe arrangement, which is why it is less expensive to install. However, it is also less efficient because larger radiators or longer baseboards are required at the end of the loop as this part of the loop gets less heat. The operation of a one-pipe system is fairly simple: water enters each radiator from the supply side of the main pipe, circulates through the radiator, and flows back into the same pipe. In boiler hydronic systems, there are different approaches to arrange the piping depending on the budget at installation time and the efficiency level required. As with many hydronic loop systems the two-pipe direct return needs balancing valves, and in both systems an expansion tank is required to compensate for variations in the volume of water in the system.

Modern layouts generally use a two-pipe layout, in which radiators are all supplied with hot water at the same temperature from a single supply

pipe, and the water from these radiators flows back to the furnace to be reheated through a common return pipe. Although the two-pipe system requires more pipe work, it is more efficient and easier to control than the one-pipe system. Another advantage of the two-pipe direct return and reverse return loop over the one-pipe series loop is that it can be zoned. Zoning offers additional control over where and when heat is required which in turn can reduce heating costs. The two-pipe system is thus more efficient and easier to control than the one-pipe system. In both systems an expansion tank is required to compensate for variations in the volume of water in the system. Closed expansion tanks contain about 50% air, which compresses and expands to compensate for volume changes in the water. Another system that is sometimes used is the sealed hot water system. This is basically a closed system that does not need water tanks because the hot water is supplied directly from the mains.

Steam Heating Systems

Steam heating systems take advantage of the high latent heat, which is given off when steam condenses to liquid water. These systems closely resemble hot water systems except that steam rather than hot water is circulated through the pipes to the radiators. Steam is often used to carry heat from a boiler to consumers as heat exchangers, process equipment, etc. Sometimes steam is also used for heating purposes in buildings. Steam heating systems closely resemble their Hydronic systems counterpart except that steam rather than hot water is circulated through the pipes to the radiators and no circulating pumps are required. The steam condenses in the radiators and/or baseboards, giving up its latent heat. Both one-pipe and two-pipe arrangements are employed for circulating the steam and for returning to the boiler the water formed by condensation. In domestic structures and small commercial buildings, the steam is generated at fairly low pressure, less than 15 pound-force per square inch gauge (psig). Three main types of steam systems used are air vent systems, vapor systems, and vacuum or mechanical pump systems. Steam heating systems are rarely installed in new single-family residential construction owing to the cost of the piping installation.

Each heating unit in a one-pipe gravity flow system has a single pipe connection through which it simultaneously receives steam and releases condensate. All heating units and the end of the supply main are sufficiently above the boiler water line so that condensate is able to flow back to the boiler by gravity. In a two-pipe system, steam supply to the heating units and condensate return from heating units are through separate pipes. Air accumulation in piping and heating units discharges from the system

through the open vent on the condensate pump receiver. Piping and heating units must be installed with proper pitch to provide gravity flow of all condensate to the pump receiver.

Vacuum systems resemble vapor systems in that each radiator is equipped with an inlet valve and a steam trap, except that they have a vacuum pump installed in the return piping. A partial vacuum is maintained with the pump in the system so that the steam, air, and condensate circulate more readily. The air is expelled into the atmosphere upon the condensate and air return to a central point from which the condensate is pumped back into the boiler.

Heat Pumps

A heat pump is a device that extracts available heat from one location and transfers it to another—unlike a furnace which creates heat. Heat pumps are actually air conditioners that run in reverse to bring heat from outdoors into the interior. This works by heating up a piped refrigerant in the outdoor air, then pumping the heat that is generated by the warmed refrigerant inside to warm the indoor air. This type of system works best in moderate climates and becomes less efficient in very cold winter temperatures, when electrical heat is needed for auxiliary heating demands. Heat pumps are most efficient when the outside temperature is in the 50°F range. This is because as the outdoor temperature begins to drop, the heat loss of a space becomes greater, requiring the heat pump to operate for longer stretches of time for it to be able to maintain a constant indoor temperature. Also, the fact that most heat pumps use atmospheric air as their heat source presents a problem in areas where winter temperatures frequently drop below freezing, making it difficult to raise the temperature and pressure of the refrigerant. As with furnaces, heat pumps are usually controlled by thermostats. A typical residential application of a water pump system is illustrated in [Fig. 9.10](#).

Reverse Cycle Chiller

This is a recently introduced heat pump variant; it is a type of heating system that uses hot water as a heat source. When the cycle is reversed, reverse cycle chillers (RCCs) have the ability to cool the room. This means the system serves a dual purpose of providing both heating and cooling solutions. The RCCs basically heat or cool an insulated tank of water and then distributes the heating or cooling either through fans and ducts or radiant floor systems. The need for auxiliary electric heating coils and defrosting cycles to prevent icing of the refrigerant is eliminated thus making these systems more suitable for cold climates than traditional heat pumps.

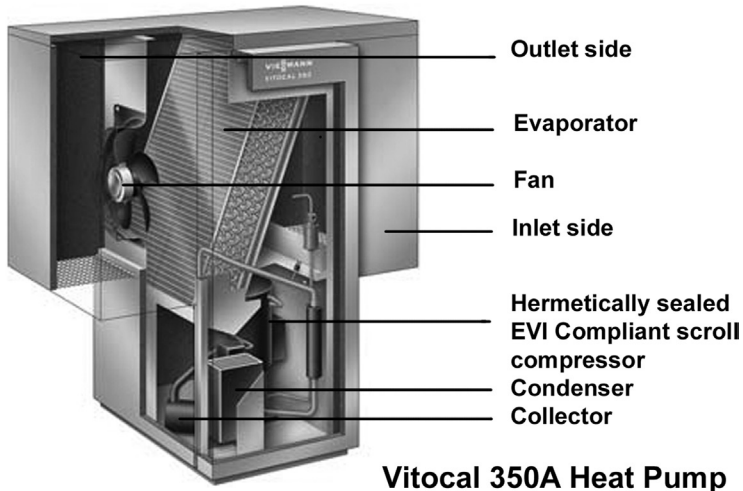

Vitocal 350A Heat Pump

Figure 9.10 The Vitocal 350A-G air/water heat pump; heating output 10.6–18.5 kW.
Source: Viessmann Werke.

Some of the benefits to using reverse chillers include energy efficiency—reverse chillers use about 25–50% of the electricity used in a whole home air conditioning system. Additionally, many are modular systems—i.e., meaning one can easily expand the size of the system if needed simply by adding a new section. Newer models also now offer solar-powered hot water heating for the unit. These systems still require an exterior condenser unit similar to traditional HVAC systems.

Geothermal Heat Pumps

Geothermal heat pumps (GHPs, sometimes referred to as GeoExchange, earth-coupled, ground source, or water source heat pumps) have been in use for several decades. It is a technology that is gaining wide acceptance for both residential and commercial buildings. Studies show that approximately 70% of the energy used in a GHP system is renewable energy from the ground and more than 45% more energy efficient than standard options. According to Energy Star, “Geothermal heat pumps (GHPs) are among the most efficient and comfortable heating and cooling technologies currently available, because they use the earth’s natural heat to provide heating, cooling, and often, water heating.” This system utilizes the relatively constant temperature of the ground or water several feet below the earth’s surface as source of heating and cooling. The earth’s constant temperature is what makes GHPs one of the most efficient (relative to air source heat

pumps), comfortable, and quiet heating and cooling technologies available today. They also last longer, need little maintenance, and do not depend on the temperature of the outside air. Some models of geothermal systems are available with two-speed compressors and variable fans for more comfort and energy savings. Setup costs are normally higher than for conventional systems, but the difference is usually reimbursed in energy savings in 3–10 years, and shorter lengths of time if federal, state, and utility tax credits and incentives are taken into account.

There are four basic classifications of ground loop systems. Three of these—horizontal, vertical, and pond/lake—are closed-loop systems. The fourth type of system is the open-loop option; these systems use well or surface water as the heat exchange fluid that circulates directly through the GHP. Once water has circulated through the system, it returns to the ground through the well, a recharge well, or surface discharge. Which one of these systems is best depends on the climate, soil conditions, available land, and local installation costs at the site. All of these approaches can be used for residential and commercial building applications. The first three classifications are described in [Table 9.2](#).

Hybrid Systems

Another technology option is the Hybrid systems using several different geothermal resources, or a combination of a geothermal resource with outdoor air (i.e., a cooling tower). Hybrid approaches are particularly effective where cooling needs are significantly larger than heating needs.

Table 9.2 Ground-loop system classifications

System	Description
Horizontal	This type of installation is generally the most cost-effective for residential installations, particularly for new construction, where sufficient land is available
Vertical	These systems are often used by large commercial buildings and schools because the land area required for horizontal loops would be prohibitive. Vertical loops are also used where the soil is too shallow for trenching, and they minimize the disturbance to existing landscaping
Pond/lake	This may be the lowest cost option if the site has an adequate body of water. A supply line pipe is run underground from the building to the water and coiled into circles at least 8ft under the surface to prevent freezing

GHPs are appropriate for retrofit or new facilities, where both heating and cooling are desired, and business owners around the United States are now installing GHPs to heat and cool their buildings. These systems can also be located indoors because there is no need to exchange heat with the outdoor air. Although this technology may be more expensive to install than traditional HVAC systems, geothermal systems will greatly reduce gas or electric bills through reduced energy, operation and maintenance costs, thus allowing for relatively short payback periods (Fig. 9.11). Conventional ductwork is generally used to distribute heated or cooled air from the GHP throughout the building.

It is important to check when selecting ground source heat pumps that the models chosen qualify for the ENERGY STAR label, or meet the recommended levels of COP (Coefficient of Performance) and EER (Energy Efficiency Ratio). Efficiency is measured by the amount of heat a system can produce or remove using a given amount of electricity. A common measurement of this performance is the Seasonal Energy Efficiency Ratio (SEER). The Federal Appliance Standards, which took effect on January 23, 2006, will require the new standards for central air conditioners be a minimum of 13 SEER. Most manufacturers now offer SEER 10, 11, 12, and 13 models, and some offer SEER 14. This translates into five separate efficiency options, with model numbers usually keyed to the SEER numbers, so they are easy to recognize. The most efficient models, however, generally involve two-speed compressors systems and variable



Figure 9.11 A residential geothermal heat pump system. *Source: Climate Heating and Cooling, Inc.*

fans and increased heat exchange area, and thus cost significantly more. But even though the installation price of a geothermal system can be several times that of an air source system of the same heating and cooling capacity, the additional costs can be recouped in energy savings in 5–10 years. System life is estimated at 25 years for the inside components and 50+ years for the ground loop. There are approximately 50,000 GHPs installed in the United States annually.

No doubt with the ongoing development of new technologies and innovations heat pump performance will continue to improve. Thus, for example, the introduction of two-speed compressors allows heat pumps to operate close to the heating or cooling capacity that is needed at any particular moment. This saves large amounts of electrical energy and reduces compressor wear. Also, some heat pumps are equipped with *variable speed* or *dual speed motors* on their indoor fans, outdoor fans, or both. The variable speed controls for these fans attempt to keep the air moving at a comfortable velocity, minimizing cool drafts and maximizing electrical savings. Another advance in heat pump technology is the introduction of a device called a *scroll compressor*, which compresses the air or refrigerant by forcing it into increasingly smaller areas. The scroll compressor uses two interleaved scrolls to pump, compress, or pressurize fluids such as liquids and gases. Some reports estimate that heat pumps with scroll compressors provide 10–15°F (5.6–8.3°C) warmer air when in the heating mode, compared to existing heat pumps with piston compressors.

Solar Thermal Collectors

The use of solar radiation for energy purposes is an ancient concept although recent concerns raised relating to the environmental impact of burning fossil fuels have made solar energy a topic of interest again. A solar thermal collector is a device designed specifically to collect heat by absorbing sunlight and may be used to heat air or water for building heating purposes. A solar collector operates on a very simple basis. The radiation from the sun heats a liquid which goes to a hot water tank. The liquid heats the water and flows back to the solar collector. Water-heating collectors may replace or supplement a boiler in a water-based heating system. Air-heating collectors may replace or supplement a furnace. Solar collectors are considered to be one of the renewable energy technologies with the best economics. They have an estimated lifetime of 25–30 years or more and require very little maintenance, only control of antifreeze and pressure in the system. Solar

water-heating collectors may also provide heated water that can be used for space cooling in conjunction with an absorption refrigeration system.

Solar systems are basically either active or passive systems. The terms passive and active in solar thermal systems refer to whether the systems rely on pumps or only thermodynamics to circulate water through the systems. As solar energy in an active solar system is typically collected at a location remote from the spaces requiring heat, solar collectors are normally associated with central systems. Solar water-heating collectors may also provide heated water that can be used for space cooling in conjunction with an absorption refrigeration system. Solar water-heating systems are generally used in hotels and homes in sunny climates such as those found in southern Europe. Since the sun provides free energy, a saving of up to 70% can be made of the energy that would otherwise be used for heating the water. Besides the economical reward there is also a significant environmental advantage. By using solar collectors for heating of water can an average family save up to 1 ton of CO₂ per year. Fig. 9.12 illustrates an example of an indirect active solar system.

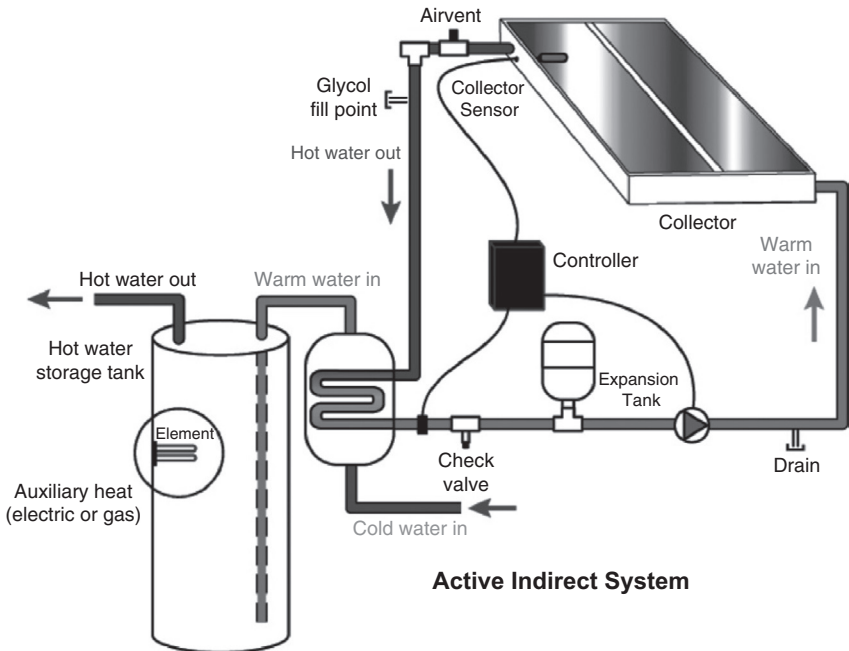

Figure 9.12 Diagram of an indirect active solar system, which is preferred in climates with extended periods of below freezing temperatures. *Courtesy, Southface Energy Institute.*

9.4.4 Ventilation

It should not surprise anyone that proper ventilation is a prerequisite to healthy indoor living. It can be accomplished passively through natural ventilation or forced ventilation through mechanical distribution systems powered by fans. The subject is discussed in greater detail in [Chapter 7](#) (Indoor Environmental Quality).

9.4.5 Air Conditioning Systems

ASHRAE's definition of an air conditioning system is a system that accomplishes four specific objectives simultaneously. These are (1) air temperature control, (2) air humidity control, (3) air circulation control, and (4) air quality control. The fact is that air conditioning systems are typically designed to provide heating, cooling, ventilation, and humidity control for a building or facility. It is much easier to incorporate air conditioning systems into new modern offices and public buildings under construction than to retrofit existing buildings because of the bulky air ducts that will require installation. Moreover, these systems must be carefully maintained to prevent the growth of pathogenic bacteria in the ducts and ensure efficient operation. Air-conditioned buildings (especially in high-rise buildings) often have sealed windows because open windows would disrupt the attempts of the control system to maintain constant air quality.

Currently there are many different types of air conditioner systems on the market, depending on individual needs and requirements. Some use direct expansion coils for cooling such as window units, package unit air conditioners, split system air conditioners, packaged terminal air conditioners like the air conditioners used in hotels, and mini-split ductless air conditioners. Other types utilized CHW for air conditioning, and these are typically commercial air conditioners for large commercial buildings. But whichever type of air conditioner is used, the coils in the air conditioner system are required to be brought to a temperature colder than the air.

When operating properly, air conditioners use direct expansion coils or CHW coils to remove the heat from the air as air is blown across the coils. The evaporator coil in an air conditioner system is responsible for absorbing heat. The evaporator and condenser both comprise of tubing, usually copper, surrounded by aluminum fins. As air (or water in a chiller) passes over the evaporator coils a heat exchange process takes place between the air and the refrigerant. The refrigerant absorbs the heat and evaporates in the indoor evaporator coils and draws the heat out of the air and cools the facility. Finally, the hot refrigerant gas is pumped (compressor) into the

outdoor condenser unit where it returns to liquid form. The main types of air conditioning systems that are currently available include:

Vapor Compression Refrigeration

The vapor compression refrigeration system is the most widely used refrigeration system today for air conditioning of large public buildings, private residences, hotels, hospitals, theaters, restaurants, and a host of other services. This approach involves the operation of a vapor compression refrigeration cycle to induce heat to travel in a direction contrary to gross environmental temperature differences. During the overheated period, the outside air temperature is expected not to be just above the balance point temperature but also above the indoor air temperature. Under such conditions, heat flow will be from higher to lower temperature (from outside to inside). To maintain thermal comfort during overly warm periods requires that heat be removed from a building, not added to it. Through a series of artificially maintained temperature and pressure conditions in a heat transfer fluid (refrigerant), a refrigeration system can induce heat to flow from inside a cooler building to an outside that is warmer. These systems all have four essential components:

- A gas compressor: This is a mechanical device that increases the pressure of a gas by reducing its volume (similar to a pump).
- A condenser: This is a device or unit used to condense a substance from its gaseous to its liquid state, typically by cooling it.
- An expansion or throttle valve (also called a valve).
- An evaporator.

Exterior Wall or Window Air Conditioning Units

Window and through-the-wall electric air conditioning units are often used in single zone applications that do not have central air conditioning installed such as small buildings and trailers. They are also used in retrofit situations in conjunction with an existing system. Basically, they are small ductless units with casings extending through the wall, and are generally noisy and designed to cool small areas, though some larger units may be able to cool larger spaces. The primary advantage of a wall unit over a window unit is that it does not occupy window space. Note that whenever a window unit is installed, part of the window becomes unusable (and reduces incoming daylight).

By removing the cover of an unplugged window unit, it will be shown that it is comprised of a number of components including a compressor, an expansion valve, a hot coil (on the outside), a chilled coil (on the inside), two fans, and a control unit (Fig. 9.13). The wall unit air conditioner works by removing hot air from the room into the unit, and the hot air that enters

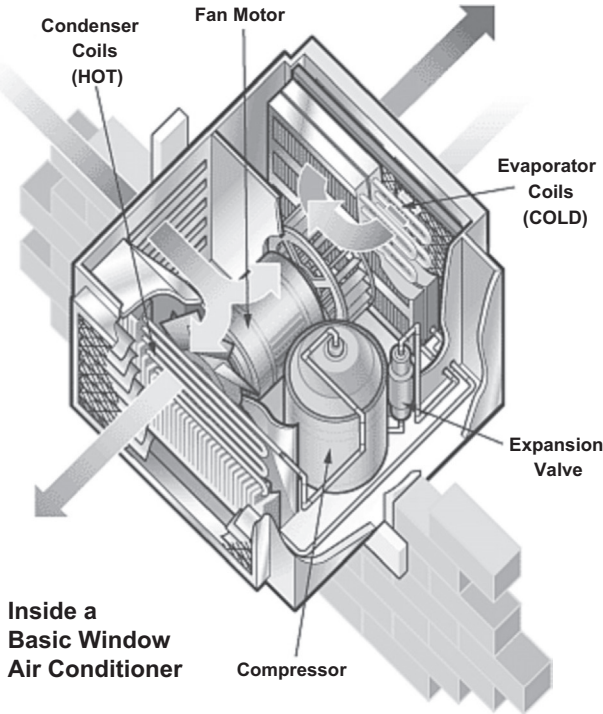

Figure 9.13 Components of a basic window AC unit: a compressor, an expansion valve, a hot coil (on the outside), a chilled coil (on the inside), two fans, and a control unit. Source: HowStuffWorks.com.

the unit is brought over the air conditioning condenser and cooled. The cooled air is then pushed back into the room. Many of the newer units incorporate significant innovations such as electronic touchpad controls, energy saver settings, and digital temperature readouts. Moreover, some of the newer units display significant innovations such as electronic touchpad controls, energy saver settings, and digital temperature readouts. A timer is another improvement now available on new air conditioning units as it allows you to set the AC to cycle on and off at certain times of the day (i.e., the air conditioner might stay off all day and turn on an hour before you are scheduled to come home from work).

Central Air Conditioning Systems

In most modern buildings, air conditioning has become one of those amenities that are frequently taken for granted, and often, particularly in relatively warm climates, we find it has become more the rule than the exception. In

addition to cooling, A/C systems are designed to dehumidify and filter air, making it more comfortable and cleaner. Central air conditioning systems consist of three main components, these are the outdoor unit (condenser and compressor), the indoor unit (blower coil or evaporator), and the indoor thermostat to regulate the temperature. The success of a central air system is dependent upon these three systems appropriately functioning together.

Likewise, the design of an air conditioning system depends among other things, on the type of structure in which the system is to be placed, the amount of space to be cooled, the function of that space, and the number of occupants using it. For example, a room or building with large windows exposed to the sun, or an indoor office space with many heat-producing lights and fixtures, requires a system with a larger cooling capacity than a space with minimal windows in which cool fluorescent lighting is used. Also, a space in which the occupants are allowed to smoke will require greater air circulation than a space of equal capacity in which smoking was prohibited. Air-conditioned buildings often have sealed windows because open windows would disrupt the attempts of the HVAC system to maintain constant indoor air conditions. This must be taken into consideration in any HVAC system design.

With the new technology and “Intelligent Building” craze taking place, many central HVAC systems today are being designed to serve more than one thermal zone with its main components being located outside of the zone or zones being served—usually at a convenient central location in, on, or near the building. Central air conditioning systems are extensively installed in offices, public buildings, theaters, stores, restaurants, and other building types. Although centralized air conditioning systems provide fully controlled heating, cooling, and ventilation, they need to be installed during construction.

In recent years, these systems have increasingly become automated by computer technology for purposes of energy conservation. In older buildings, indoor spaces may be equipped with a refrigerating unit, blowers, air ducts, and a plenum chamber in which air from the interior of the building is mixed with air from the exterior. Such installations are used for cooling and dehumidifying during the summer months, and the regular heating system is used during the winter. [Fig. 9.14](#) shows the general components of a small central air conditioning system that can be used in small commercial buildings or residences.

Split System

A split air conditioner consists of two main parts: the outdoor unit and the indoor unit. It generally implies that the condenser and compressor are

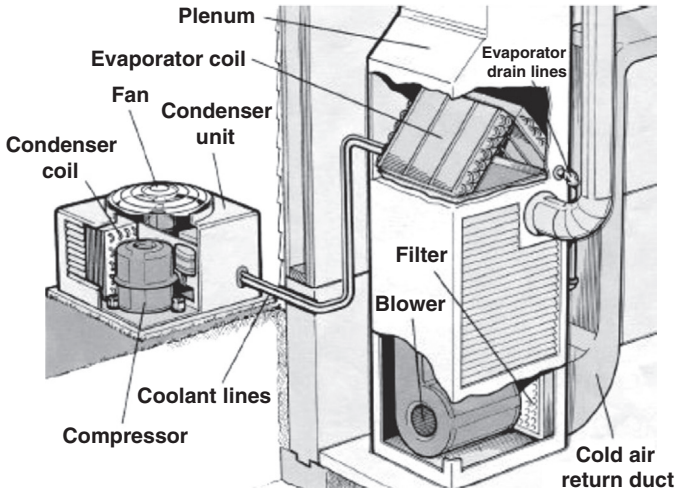

Figure 9.14 Domestic central air conditioners are made up of two basic components: the condenser unit, located outside the house on a concrete slab, and the evaporator coil above the furnace. These components in turn also comprise of several elements. *Source: HowStuffWorks.com.*

housed in an outdoor cabinet and the refrigerant metering device and the evaporator housed in an indoor cabinet. With many split system air conditioners, the indoor cabinet also houses a furnace or a part of the heat pump. The cabinet or main supply duct of this furnace or heat pump also houses the air conditioners evaporator coil. For reverse cycle applications, the heat exchangers can swap roles, with the heat exchanger exposed to outside air becoming the evaporator and the inside heat exchanger becoming the condenser (Fig. 9.15). Split systems may have a variety of configurations. The four basic components of the vapor compression refrigeration cycle—compressor, condenser, refrigerant metering device, and evaporator—can be grouped in several ways. The grouping of components is based on practical considerations, such as available space, ease of installation, keeping noise outside occupied spaces, etc. Split systems are generally more expensive to purchase, but potentially less expensive to install, and a ductless system is practical for homes that do not already have ductwork. The big advantage of a ductless mini-split system is that you can adjust temperature levels for individual rooms or areas.

Where the condensing unit is quite large such as in the case of department stores, businesses, malls, warehouses, etc., it is normally located on the roof. Alternatively, there may be many smaller units on the roof, each

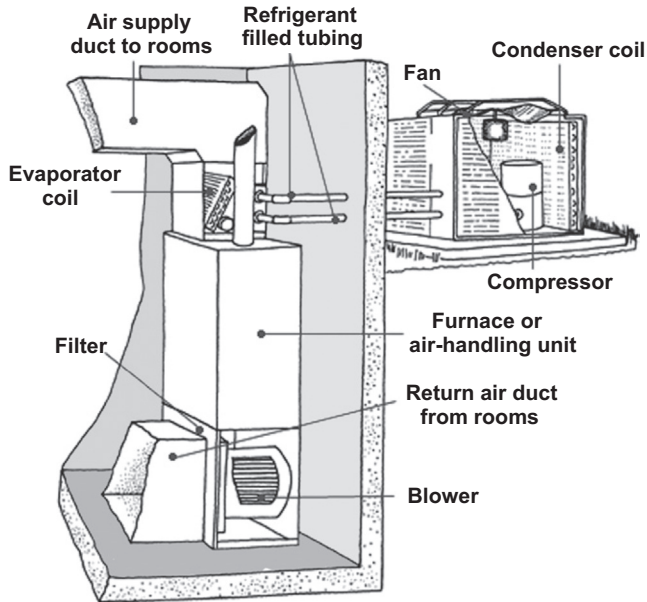

Figure 9.15 A drawing illustrating how a split system works. With a typical “split system,” the condenser and the compressor are located in an outdoor unit; the evaporator is mounted in the AHU, which is often a forced-air furnace. With a “package system,” all of the components are located in a single outdoor unit that may be located on the ground or on the roof of the house. *After: HomeTips.com.*

attached inside to a small air handler that cools a specific zone in the building. The split system approach may not always be suitable for larger buildings and particularly in multistory buildings, because problems start to appear such as the distance between the condenser and the air handler exceeds pipe distance limitations, or the amount of duct work and the length of ducts cease to be viable.

Packaged Systems

Packaged systems are all-in-one solutions, where most of the components for heating and/or cooling are housed in a single cabinet. The main difference between a package unit and the split system unit is that a split system uses indoor and outdoor components to provide a complete comfort system whereas a package unit or self-contained unit requires no external coils, air handlers, or heating units. Packaged air conditioner models are used for medium-sized halls and multiple rooms on the same floor and are usually used for applications where air conditioning of more than 5

tons is required. Packaged units commonly use electricity to cool and gas to heat. Packaged systems typically have all their components located in a single outdoor unit located either on the ground or roof. A packaged rooftop unit is a self-contained AUH, typically used in low-rise buildings, and mounted directly onto roof curbs, discharging conditioned air into the building's air duct distribution system. Packaged HVAC systems will typically contain:

- The air conditioner/heat pump together with the evaporator/fan coil all in one unit
- Thermostat/control interface to enable complete control of the system
- Optional air quality improvers, such as air purifiers, cleaners, ventilators, or UV lamps, which are designed to further clean the air before it circulates within the home or office.

AUHs come in many capacities, from units of just over one ton to systems of several hundred tons that contain multiple compressors and designed for single or multiple-zone application.

9.4.6 Basic Heating, Ventilating, and Air Conditioning System Types

All-Air Systems

These systems represent the majority of systems currently in operation. All-air systems basically transfer cooled or heated air from a central plant via ducting, distributing air through a series of grilles or diffusers to the room or rooms being served. It normally comprises the cheapest equipment cost but is not necessarily the cheapest or easiest to install in a building due to the size of ducting required and the cost to install. It can also be a problem to properly control the temperature, and also the system may be energy inefficient. The overall energy used to cool buildings with all-air systems includes the energy necessary to power the fans that transport cool air through the ducts. Because the fans are usually placed in the air stream, fan movement heats the conditioned air (Fig. 9.16a), thus adding to the thermal cooling peak load. For optimum efficiency, constrictions and sharp changes of direction should be avoided.

All-Water Systems

Robert McDowall, author of *Fundamentals of HVAC systems*, says “When the ventilation is provided through natural ventilation, by opening windows, or other means, there is no need to duct ventilation air to the zones from a central plant. This allows all processes other than ventilation to be

provided by local equipment supplied with hot and chilled water from a central plant.” These systems are generally grouped under the name “all-water systems.” The heating systems represent the largest group of all-water systems. McDowall also notes that “Both the air-and-water and all-water systems rely on a central supply of hot water for heating and chilled water for cooling.”

The conditioning effect in these systems is distributed from a central plant to conditioned spaces via heated or cooled water. Water is an effective heat transfer medium, thus distribution pipes are often of relatively small volume (compared to air ducts). On the other hand, water cannot be directly dumped into a space through a diffuser but requires a more sophisticated delivery device. All-water heating-only systems employ a variety of delivery devices, such as baseboard radiators, convectors, unit heaters, and radiant floors. All-water cooling-only systems are rare with

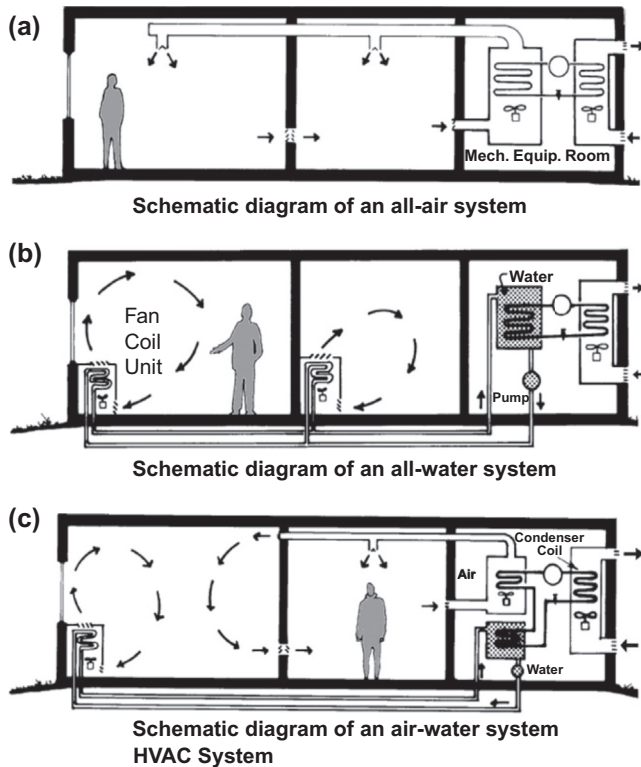

Figure 9.16 Diagram illustrating three basic HVAC systems. (a) All-air system (b) all-water system (c) air–water system. *After N. Lechner.*

valance units being the most common delivery device for such systems (Fig. 9.16b). When full air conditioning is contemplated, the most appropriate delivery device may be the fan coil unit. All-water systems are generally the most expensive to install and own and are classed as the least energy efficient in terms of transfer of energy. Also since water-cooled systems use a cooling tower, it is imperative to ensure that this is properly maintained, otherwise it can lead to problems with legionella or legionnaires disease.

Air–Water Systems

This is another category of central HVAC systems that distribute conditioning effect by means of heated or CHW and heated or cooled air from a central plant (Fig. 9.16c). In an Air–Water system, both air and water are used for providing the required settings in the conditioned space. The air supplied to this space from the central plant is known as primary air, while the water supplied from the plant is referred to as secondary water. Thus the complete system will consist of a central plant for cooling or heating the water and air, as well as a ducting system with fans for conveying the air, and water pipelines and pumps for transmission of the water and a room station. The room station or terminal may take the form of a radiation panel, a fan coil unit, or an induction unit. However, it should be noted that there are several disadvantages in using an air–water system as compared to an all-air systems, such as controls are more complex and complicated due to the need for handling and controlling both primary air and secondary water.

9.4.7 Heating, Ventilating, and Air Conditioning System Requirements

The HVAC industry has been changing at an unusually rapid pace over the last few years and it appears that this trend is likely to continue. It is most important to be aware of regulatory changes, business technologies, and product manufacturing that designers and contractors will be facing. HVAC professionals should also be aware that building spaces such as cavities between walls can support platforms for air handlers, and plenums defined or constructed with materials other than sealed sheet metal, duct board, or flexible duct must not be used for conveying conditioned air including return air and supply air. Care should be taken to ensure that ducts installed in cavities and support platforms are not compressed in a manner that would cause reductions in the cross-sectional area of the ducts.

Connections between metal ducts and the inner core of flexible ducts must be mechanically fastened and openings must be sealed with mastic, tape, or other duct closure systems that meet the codes and standards of local jurisdictions. It should be noted that in most jurisdictions national building codes stipulate that access be provided to certain components of mechanical and electrical systems. This is usually required for maintenance and repair and includes such elements as valves, fire dampers, heating coils, mechanical equipment, and electrical junction boxes. Commercial construction usually takes advantage of ceiling plenums to run horizontal ducts while vertical ducts are contained within their own chases. Depending on the type of structure and depth of the plenum, large ducts may occupy much of this depth, leaving little if any space for recessed light fixtures. Where the plenum is used as a return air space, most local and national building codes prohibit the use of combustible materials such as wood or exposed wire within the space in commercial building projects.

Certain occasions in commercial construction may necessitate the use of access flooring (typically in computer room applications), which consists of a false floor of individual panels raised by pedestals above the structural floor. This is designed to provide sufficient space to run electrical and communication wiring as well as HVAC ductwork. Sometimes small pipes are designed to run within a wall system, whereas larger pipes may need deeper walls or even chase walls to accommodate the pipes. Fan systems that exhaust air from the building to the outside must be provided with back draft or automatic dampers. Gravity ventilating systems must have an automatic or readily accessible, manually operated damper in all openings to the exterior, except combustion inlet and outlet air openings and elevator shaft vents.

9.4.8 Common Heating, Ventilating, and Air Conditioning Deficiencies

It has been found that the most common deficiencies stem from water, which insidiously finds its way to places inside the system, where it corrodes and damages material components and creates a lush growth place for bacteria and other health-threatening organisms. The seriousness of this health threat can be appreciated especially when it is recognized that all the air in a building passes through the air conditioning system several times per hour. Therefore, when maintenance of the equipment is deferred or performed by unqualified personnel, the system will likely increasingly experience problems. However, when properly maintained, a building's HVAC system

can enjoy a substantial life span. HVAC deficiencies fall into two main categories: (1) issues that are fairly simple to address, such as filter or belt replacement, and (2) complex issues requiring the attention of specialized personnel, such as pump or boiler replacement. Another deficiency often encountered is inadequacy of the system for the size of the facility. Most designers of mechanical systems now utilize computer analysis software to determine heating and cooling loads, but a general rule of thumb in an assessment is to compare the actual tonnage of the unit to the standard design tonnage using the formulas below:

$$\text{BTU of Unit} \div 12,000 = \text{actual tonnage of the unit}$$
$$\text{Square footage of the building} + 350 = \text{design tonnage.}$$

Deficiencies and other issues that need to be checked for conformance when conducting HVAC evaluations of existing buildings include the following:

- Evidence of abnormal component vibrations or excessive noise.
- Evidence of unsafe equipment conditions, including instability or absence of safety equipment (guards, grills, or signage).
- The presence of drafts in the room or space being cooled.
- Identify the location of the thermostats.
- Does the building have an exhaust system and are the toilets vented independently or mixed with the common area venting system?
- Insufficient air movement to reach all parts of the room or space being cooled or alternatively, the presence of drafts in the room or space being cooled.
- Return air at the return registers is not at least 10–15°F warmer than the supply air.
- Evidence of leaking caused by inadequate seals.
- Is there a fresh air make up system in the building.
- Evidence of fan alignment deficiencies, deterioration, corrosion, or scaling.

9.4.9 Heating, Ventilating, and Air Conditioning Components and Systems

HVAC systems are the main energy consumers in most buildings, accounting for approximately half of all the energy used in US buildings. And in addition to the energy costs, HVAC systems impact building occupants' health, comfort, and productivity. Therefore, improving HVAC performance saves energy and promotes a healthier, more comfortable interior working conditions, which are key functions of an HVAC system (Fig. 9.17). HVAC

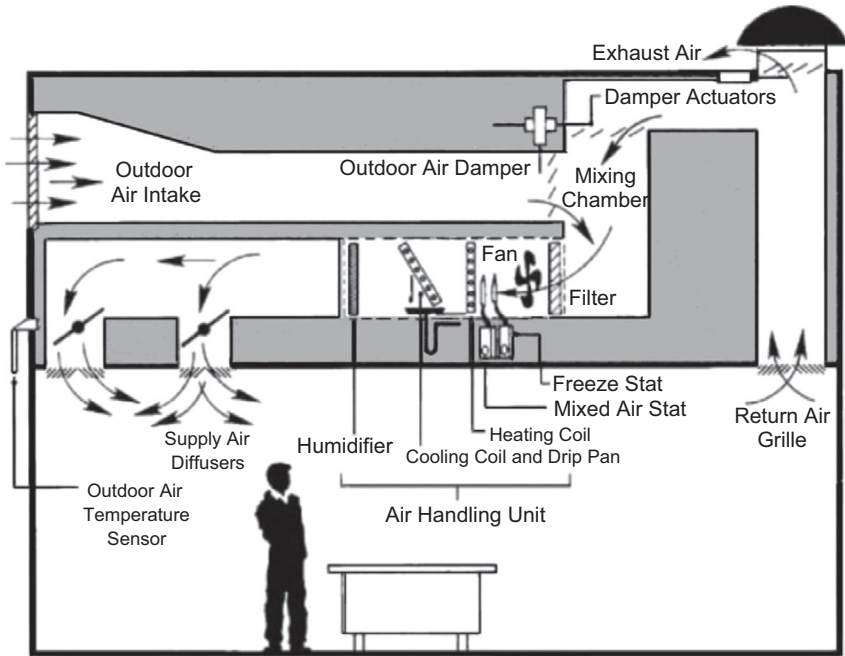

Figure 9.17 Drawing showing typical HVAC (heating, ventilating, and air conditioning) system components that deliver conditioned air to a building or space to maintain thermal comfort and IAQ. *Source: Terry Brennan, Camroden Associates.*

systems generally include a number of active mechanical and electrical systems employed to provide thermal control in buildings. Control of the thermal environment is one of the key objectives of virtually all occupied buildings. Numerous systems and components are used in combination to provide fresh air, as well as temperature and humidity control in both residential and commercial properties.

HVAC system components can generally be grouped into three functional categories: (1) source components, (2) distribution components, and (3) delivery components.

Source Components generally provide or remove heat or moisture. There are four basic types of heat sources employed in buildings: (1) On-site combustion (fuel such as natural gas or coal), (2) Electric resistance (converting electricity to heat), (3) Solar collector on roof to furnace, and (4) Heat pump in furnace. Choosing a heat source for a given building depends on several factors such as source availability, fuel costs, required system capacity, and equipment costs.

Distribution Components are used to convey a heating or cooling medium from a source location to portions of a building that require conditioning. Central systems produce a heating and/or cooling effect in a single location, which is then transmitted to the various spaces in a building that require conditioning. Three transmission media are commonly used in central systems: air, water, and steam. Hot air can be used as a heating medium, cold air as a cooling medium. Hot water and steam can be used as heating media, while cold water is a common cooling medium. When a central system is used, it will always require distribution components to convey the heating or cooling effect from the source to the conditioned locations.

Delivery Components basically serve as an interface between the distribution system and occupied spaces. The heating or cooling effect produced at a source and distributed by a central system to all the spaces within a building has to be properly delivered to each space to promote comfort and well-being. In air-based systems, the dumping of heated or cooled air into each space does not provide the control over air distribution required of an air conditioning system. Likewise, with water-based systems, the heated or cooled media (water or steam) cannot just be dumped into a space. Some means of transferring the conditioning effect from the media to the space is required. “Delivery devices” are designed to provide the interface between occupied building spaces and distribution components.

Normally, when compact systems that only serve a single zone of a building, they frequently incorporate all three functions in a single piece of equipment, whereas systems that are intended to condition multiple spaces in a building (central systems) usually employ distinctly different equipment elements for each function. Furthermore, for each commercial property type, some systems will perform better than others. However, from a lender’s perspective, performance is judged by how well the needs of tenants and owners are met regarding comfort, operating costs, aesthetics, flexibility, and reliability.

Ductwork

The main objective of duct design is to provide an efficient distribution network of conditioned air to the various spaces within a building or complex. To achieve this, ducts must be designed to facilitate air flow and minimize friction, turbulence, and heat loss and gain. Optimal air distribution systems have correctly sized ducts with minimal runs, smooth

interior surfaces, and minimum direction and size changes. Ducts that are badly designed and installed can result in poor air distribution, poor IAQ, occupant discomfort, additional heat losses or gains, increased noise levels, and increased energy consumption. Duct system design requirements and construction can be impacted by the design of the building envelope. A duct system's overall performance can also be impacted by the materials used. Fiber glass insulation products are currently used in the majority of duct systems installed in the United States and serve as key components of well-designed, well-operated, and well-maintained HVAC systems that provide both thermal and acoustical benefits for the life of the building. Other materials commonly used for low-pressure duct construction include sheet metal (galvanized steel), black carbon steel, aluminum, stainless steel, fiberglass-reinforced plastic, polyvinyl steel, and concrete.

HVAC professionals strongly advise to put in place a preventive maintenance inspection program that will help identify system breaches that are typically more prevalent at duct intersections and flexible connections. Supply and return air may both utilize ductwork, which may be located in the ceiling cavity or below the floor slab, depending on the configuration of the system. In single-duct systems, both cool air and hot air utilize the same duct, and in double-duct systems, separate ducts are used for cooling and heating. It should be noted that air flowing through a duct system will encounter friction losses through contact with the duct walls and in passing through the various devices such as dampers, diffusers, filters, and coils. To overcome these friction losses, a fan is utilized which provides both the energy input required to overcome friction losses and also to circulate air through the system. Whether a central HVAC system requires the use of several fans for air supply and return, and for exhaust air is determined by the size of the ductwork to be used. The use of fire dampers will be required whenever ducts penetrate a fire wall. Modern fire dampers contain a fusible link that melts and separates when a particular temperature is reached, causing it to slam shut in the event of a fire. Another major factor that impacts the fabrication and design of duct systems and that has to be considered is that of acoustics, and unless the ducting system is properly designed and constructed, it can act as large speaker tubes transmitting unwanted noise throughout the building. Splitters and turning vanes are often used to reduce the noise that is generated within the ducts.

Grills, Registers, and Diffusers

These are generally employed in conjunction with ductwork and assist in controlling the return, collection, and supply of conditioned air in HVAC

systems. A *grille* is basically a decorative cover for return air inlets; it does not have an attached damper and in most cases, has no moving parts. However, a grille can be used for both supply air and return air. The same is not true for a register or diffuser. Grills are also used to block sightlines to prevent persons from seeing directly into return air openings. A *diffuser* is an air flow device designed primarily to discharge supply air into a space, mix the supply air within the room air, and to minimize unwelcomed drafts. *Registers* are adjustable grill-like devices that cover the opening of a duct in a heating or cooling system, providing an outlet for heated or cooled air to be released into a room. They are similar to diffusers except that they are designed and used for floor or sidewall air supply applications or sometimes as return air inlets. A register differs from a grille in that a damper is included. The grills, registers, and diffusers introduce and blend the fresh air with the air of another location. When fitted together, the grills take in fresh air, the registers blow the air out, and the diffusers scatter the air in the required space within the building.

Thermostats

These are devices whose principal function is to control the operation of HVAC systems, turning on heating or cooling as required. Today's new technologies have had an enormous impact on thermostat design. And one cannot overstate the importance of staying up to date on the latest industry technologies. Contractors who fail to do so may find themselves out of business before they know it. According to APS, which is a subsidiary of Pinnacle West Capital Corp., "Modern programmable thermostats provide the basic function of maintaining comfortable indoor temperatures, but they include other valuable features as well. First, they can be programmed to automatically raise or lower the temperature of your facility according to schedules that you define. Manufacturers claim that you can save three to four percent for each degree you lower your thermostat in the winter and raise it in the summer. Most programmable thermostats allow you to input weekday and weekend schedules. The most sophisticated thermostats will control humidity, outdoor air ventilation, and inform you when the air conditioning filters need to be changed. Some modern thermostats can also include a communications link and demand management features that can be used to reduce air conditioning system energy use during periods of peak electrical demand or high electricity costs. Programmable thermostats can also be combined with HVAC zone control systems to provide optimal comfort and efficiency throughout the

facility. When combined with programmable thermostats, manufacturers claim that zoning systems can save up to 30% on heating and cooling costs while providing superior comfort.”

Boilers and heating systems are now using thermostats to prevent overheating and also control the temperature of the circulating water. Thermostats are fitted to hot water cylinders, boilers, radiators, and in rooms. Thermostat location should be coordinated with light switches, dimmers, and other visible control devices. They are typically placed 48–60 inches above the floor and away from exterior walls and heat sources.

Control of an HVAC system is pivotal to its successful operation. HVAC systems can have single-zone or multizone capabilities. In a single-zone system, the entire building is considered one area, whereas in a multizone system, the building is divided into various zones, allowing specific control of each area. In fact many of today’s newest HVAC systems are designed to incorporate individually controlled temperature zones to improve occupant comfort and provide the ability to manage the heating or cooling of individual rooms or spaces by use. Additionally, it allows us to adjust individual room temperatures for individual preferences and to close off airflow to areas that are rarely used. A zoned HVAC system is typically provided with a series of dampers. The use of zone dampers can save on the installation cost of multiple unit systems. But whether zoning with one HVAC unit using zone dampers or using multiple HVAC units, zoning can save on utility and maintenance costs. More importantly perhaps, the design of the duct system for today’s zoning is an important factor to a comfortable and efficient zoning system.

Likewise, zoning and high efficiency equipment can substantially increase the overall energy performance of a home or office while maintaining rising energy costs to manageable level. Zoning systems can automatically direct the flow of the conditioned air to those zones needing it and at the same time automatically switch over and provide the opposite mode to other zones eliminating the need for constant balance and outlet adjustments based upon continuously changing indoor conditions. But zoning represents just one of several actions that are designed to improve HVAC performance and which gives building occupants personal climate control throughout their work environment.

Boilers

Modern boilers have come a long way in design and technology. For example, today’s modern boilers feature advanced controls, efficient heating,

and are easily integrated into existing boiler systems, thereby providing lower energy costs for tenants, building owners, and facility managers. Boilers are essentially heating system components designed to generate steam or hot water for distribution to various building spaces (Fig. 9.18). But the future of boiler design lies mainly in its integration with renewable heating sources such as solar energy, geothermal, wind, and biomass. As water cannot be used to directly heat a space, boilers are currently only used in central systems where hot water is circulated to delivery devices (such as baseboard radiators, unit heaters, convectors, or AHUs). Once the delivery device is heated with the hot water, the water is returned back to the boiler to be reheated and the water circulation loop continues. Generally speaking, hot water boilers are more efficient than steam boilers for several reasons. For example, there is less heat loss throughout the hot water piping and the shell of the boiler because a hot water boiler operates at a lower temperature than a steam boiler. This means there is less heat loss throughout the entire boiler and piping system. Also, because a hot water boiler operates at a lower temperature, it requires less fuel or energy to convert into heat. An on-site solar energy collection system may serve in lieu of a boiler. Heat transfer systems (heat pumps) likewise may serve as a substitute for a boiler. Constructed of

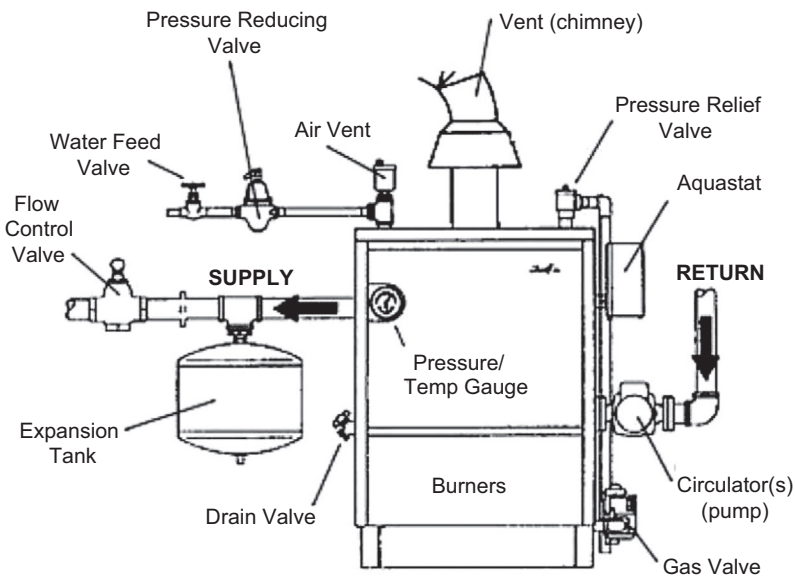

Figure 9.18 Drawing of a gas-fired hot water boiler showing main components. Courtesy: Home-Cost.com.

cast iron or steel, and occasionally copper, boilers can be fired by various fuel sources including natural or propane gas, electricity, coal, oil, steam or hot water, and wood.

Chilled Water Systems

CHW systems are typically used for cooling and dehumidifying a building's air, by circulating it throughout a building or campus complex. CHW systems also may be used for removing process or other heating loads. Essentially, these cooling systems remove heat from one element (water) and move it into another element, which is either ambient air or water. They are a key component of air conditioning systems for large buildings although they typically use more energy than any other piece of equipment in large buildings. It is similar to an air conditioning system in that it is compressor based but a chiller cools liquid while an air conditioning system cools air. Other components are a reservoir, recirculating pump, evaporator, condenser, and a temperature controller. Chillers vary in terms of condenser cooling method, cooling specifications, and process pump specifications. The cooling fluid used is usually a mix of ethylene glycol and water.

Chillers can either be *air-cooled*, *water-cooled*, or *evaporatively cooled*. Water-cooled chillers incorporate the use of cooling towers, which improve the chillers' thermodynamic effectiveness as compared to air-cooled chillers. This is due to heat rejection at or near the air's wet-bulb temperature rather than the higher, sometimes much higher, dry-bulb temperature. Evaporatively cooled chillers are more efficient than air cooled but less efficient than water cooled. Air-cooled chillers are usually located outside and consist of condenser coils cooled by fan-driven air. Water-cooled chillers are typically located inside a building, and the heat from these chillers carried by recirculating water to outdoor cooling towers. Evaporatively cooled chillers are basically water-cooled chillers in a box. These packaged units cool the air by humidifying it and then evaporating the moisture.

CHW systems are mainly employed in modern commercial and industrial cooling applications although there are some residential and light commercial HVAC CHW systems in use. One of the reasons behind the popularity of CHW systems is because they use water as a refrigerant. Water is much less expensive than refrigerant, which makes them cost-effective especially in commercial HVAC air conditioning applications. Thus, instead of running refrigerant lines over a large area of the building, water pipes are run throughout the building and to evaporator coils in air handlers for HVAC air conditioning systems. The CHW is pumped through these pipes

from a chiller where the evaporator coil absorbs heat and returns it to the chiller to reject the heat. Maintaining them well and operating them smartly can yield significant energy savings.

There are two main types of chillers commonly used today: the *compression chiller* and the *absorption chiller*. Absorption chillers use heat to drive the refrigeration cycle, they produce CHW while consuming just a small amount of electricity to run the pumps on the unit. Absorption chillers generally use steam or hot water to drive the lithium bromide refrigeration cycle but can also use other heat sources. Thus, during the compression cycle, the refrigerant passes through four major components within the chiller: the evaporator, the compressor, the condenser, and a flow-metering device such as an expansion valve. The evaporator is the low-temperature (cooling) side of the system and the condenser is the high-temperature (heat-rejection) side of the system. Compression chillers, depending on the size and load, use different types of compressors for the compression process. Mechanical compression chillers, for example, are classified by compressor type: reciprocating, rotary screw, centrifugal, and frictionless centrifugal. Modern dual compressor centrifugal chillers offer many advantages over conventional chillers. From a performance point of view, the chiller is most efficient at 50% capacity. At this point, only one compressor is operating and the evaporator and condenser are twice the size normally used for the compressor size. An advantage a dual compressor chiller offers over a VFD chiller is it does not require significant condenser water temperature relief to provide the savings.

Factors that can impact the choice of a water-cooled chiller or an air-cooled unit include whether a cooling tower is available or not. The water chiller option is often preferred over the air-cooled unit because it costs less, has a higher cooling capacity per horsepower, and consumes less energy per horsepower. Compared to water, air is a poor conductor of heat, making the air-cooled chiller much larger and less efficient which is why it is less frequently used unless it is not possible to construct a water cooling tower.

Cooling Towers

Cooling towers are often found in commercial and industrial sites, helping to keep components cool and to allow the HVAC system to do its job with less stress and strain. The principal function of a cooling tower is to remove heat from the water discharged from the condenser so that the water can be discharged to the environment or recirculated and reused. Cooling towers are used in conjunction only with water-cooled chillers and vary in size from small rooftop units to very large hyperboloid structures. Cooling towers are also characterized by the means by which air is moved. *Mechanical*

draft cooling towers are the most widely used in buildings and rely on power-driven fans to draw or force the air through the tower. They are normally located outside the building.

The two most common types of mechanical draft towers to the HVAC industry are *induced draft* and *forced draft*. Induced draft towers have a large propeller fan at the top of the tower (discharge end) to draw air upward through the tower while warm condenser water spills down. This type requires much smaller fan motors for the same capacity than forced draft towers (Fig. 9.19). Forced draft towers utilize a fan at the bottom or side of the structure. Air is forced through the water spill area and discharged out the top of the structure. After the water has been cooled in the cooling tower, it is pumped to a heat exchanger or condenser in the refrigeration unit where it picks up heat again and is returned to the tower. But like most HVAC components, cooling towers require regular care and maintenance to keep working properly.

Condensers

Air Conditioner Condensers are among the most important components to an Air Conditioning System. They form an essential part of air conditioning systems to cool and condense the refrigerant gas that becomes hot during the evaporation stage of the cooling process. There are two common condenser types, these are air-cooled and cooling tower. Achieving the cooling process is accomplished through the use of air, water, or both.

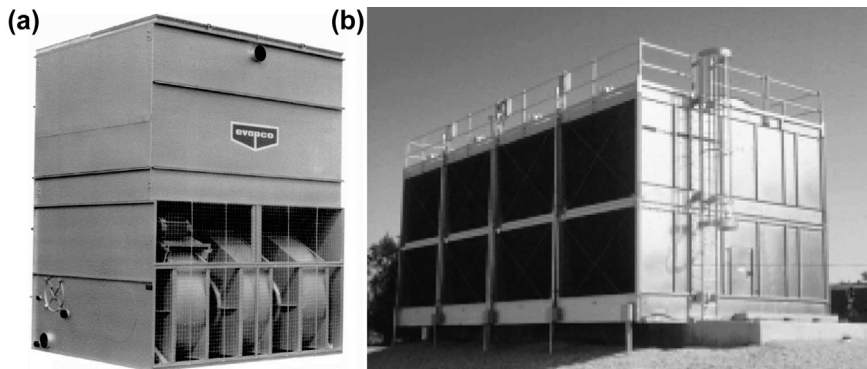

Figure 9.19 (a) Forced draft towers with fans on the air inlet to push air either counterflow or cross-flow to the movement of the water. (b) Induced draft towers have a large propeller fan at the top of the tower to draw air counterflow to the water. Induced draft towers are considered to be less susceptible to recirculation, which can result in reduced performance. *Source: McQuay International.*

Air Filters

The main purpose of using air filters is to remove particles and contaminants from the air. They are a critical component of the air conditioning system; without them, air conditioning systems would become dirty and the interior environment would be filled with pollutants and become unhealthy (Fig. 9.20). Although no individual product or system in itself can be LEED-certified, proper employment of air filtration systems provides tangible ways to improve IAQ and energy efficiency and can contribute to the completion of LEED prerequisites and credits. This is why the right filter media strategy is important and can help buildings become “greener” and meet LEED and other green building rating system criteria. Filters are designed to trap and hold the various types of particulates and contaminants that could affect a person’s health and comfort, including:

- Dust and dirt
- Pollen
- Mold and mold spores
- Fibers and lint
- Metal, plaster, or wood particles
- Hair and animal fur
- Bacteria and microorganisms.

Filtration usually occurs when expended air is brought back into the HVAC equipment to be conditioned and distributed again. The air is forced

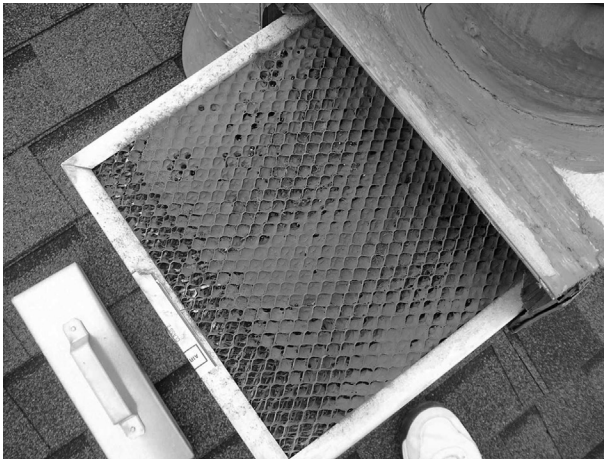

Figure 9.20 A photograph showing a clogged filter that has been removed from an AC unit. It is critically important to change filters periodically to minimize pollution and improve IAQ (indoor air quality).

through the filter, allowing it to remove particulates and other contaminants from the air.

The LEED V4 Reference Guide (depending on the LEED certification targeted) should be consulted for the latest updates and more detailed information relating to achievable credits. For example for EQ Credit 3.1 (Construction IAQ Management Plan: During Construction: “If permanently installed air handlers are used during construction, filtration media with a Minimum Efficiency Reporting Value (MERV) of 8 shall be used at each return air grille, as determined by ASHRAE 52.2-1999”). Upon completion of construction and prior to occupancy (after all interior finishes completed), new MERV 13 filters should be installed followed by a 2-week building flush-out by supplying a total air volume of 14,000 cubic foot of outdoor air per square foot of floor area. Also for NC EQ Credit 5: Indoor Chemical & Pollutant Source Control, the reference guide states, “In mechanically ventilated buildings, provide regularly occupied areas of the building with new air filtration media prior to occupancy that provides a Minimum Efficiency Reporting Value (MERV) of 13 or better. Filtration should be applied to process both return and outside air that is to be delivered as supply air.”

It is necessary to understand ASHRAE 52.1 and 52.2 in order to be able to identify what to look for when selecting the right filter to meet IAQ and energy efficiency requirements to help achieve green building standards. On this point, Dave Matela of Kimberly–Clark Filtration Products says, “One of the biggest determining factors is filtration efficiency, which defines how well the filter will remove contaminants from air passing through the HVAC system. Initial and sustained efficiency are the primary performance indicators for HVAC filters. Initial efficiency refers to the filter’s efficiency out of the box or immediately after installation. Sustained efficiency refers to efficiency levels maintained throughout the service life of the filter. Some filters have lower initial efficiency and do not achieve high efficiency until a ‘dirt cake’ builds up on the filter. Other filters offer both high initial, as well as sustained, efficiency, meaning they achieve an ideal performance level early and maintain that level.”

Of the various types of air conditioning filters on the market, the most common types are conventional fiberglass disposable filters (1 and 2 in.), pleated fiberglass disposable filters (1 and 2 in.), electrostatic filters, electronic filters, and carbon filters. Most air conditioning filters are sized 1 1/2–2 square feet for each ton of capacity for a home or commercial property. Applying MERV Rating is a good way to help evaluate the effectiveness

of a filter. **MERV** means **Minimum Efficiency Reporting Value**, which was developed by the American Society of Heating, Refrigeration and Air Conditioner Engineers—ASHRAE. MERV values vary from 1 to 16, and the higher the MERV value is the more efficient the filter will be in trapping airborne particles. Another consideration is air flow through the HVAC system. Leaving a dirty air filter in place or using a filter that is too restrictive may result in low air flow and possibly cause the system to malfunction. Of note, there are various types of filters with a MERV 13, each having different design requirements and pressure drop. It would be prudent therefore for building owners and designers to consult with a Certified Air Filter Specialist (CAFS) to obtain the best information on the optimum filters and prefilters to obtain LEEDS certification. Filters should be selected for their ability to protect both the general IAQ as well as HVAC system components.



9.5 ELECTRICAL POWER AND LIGHTING SYSTEMS

Rising energy costs and government regulations are some of the reasons why people are rethinking their energy consumption. Growing awareness of climate change and dwindling resources are other factors why energy efficiency is becoming increasingly important in everyday life. Fortunately, the production and transmission of electricity is relatively efficient and inexpensive, although unlike other forms of energy, electricity is not easily stored and therefore must typically be used as it is being produced. Electrical systems can provide a facility with accessible energy for heating, cooling, lighting, and equipment (telecommunication devices, personal computers, networks, copiers, printers, etc.) and appliance operation (e.g., refrigerators and dishwashers). It has witnessed dramatic developments of the last few decades, comprising the fastest-growing energy load within a building. More than ever, facilities today need electrical systems to provide power with which most of the vital building systems operate. These systems control the energy required in the building and distributes it to the location utilizing it. Most frequently, distribution line voltage carried at utility poles is delivered at 2400/4160 volts. Transformers step down this voltage to predefined levels for use within buildings. In an electric power distribution grid, the most common form of electric service is through the use of overhead wires known as a *service drop*, which is an electrical line running from a utility pole to a customer's building or other premises, and it is the point from where customers receive their power from the electric utilities.

However, it should be noted that there are currently several new building management programs on the market that are not only well suited to control individual systems but also allows one to integrate and intelligently link the many building disciplines from HVAC to lighting and shading systems, fire safety, power, and security.

In residential installations in North America and countries that use their system a service drop comprises of two 120 volt lines and a neutral line. When these lines are insulated and twisted together, they are referred to as a *triplex* cable. In order for these lines to enter a customer's premises they must usually first pass through an electric meter, and then the main service panel which will usually contain a "main" fuse or circuit breaker (CB). This CB controls all of the electrical current entering the building at once, and a number of smaller fuses/breakers, which protect individual branch circuits. There is always a main shutoff switch to turn off all power; when CBs are used this is provided by the main CB. The neutral line from the pole is connected to an earth ground near the service panel; often a conductive rod driven into the earth. For residential applications the service drop provides the building with two separate 120 volt lines of opposite phase, so 240 volts can be obtained by connecting a circuit between the two 120 volt conductors, while 120 volt circuits are connected between either of the two 120 volt lines and the neutral line. 240 volt circuits are used for high-power devices and major appliances, such as air conditioners, clothes dryers, ovens, and boilers, while 120 volt circuits are used for lighting and ordinary small appliances. As these are only "nominal" numbers, it means that the actual voltage may vary.

In many countries around the world including Europe, a three-phase 416Y/230 system is used. The service drop consists of three 240 volt wires, or phases, and a neutral wire which is grounded. Each phase wire provides 240 volts to loads connected between it and the neutral. Each of the phase wires carries 50 Hz alternating current which is 120° out of phase with the other two. The higher voltages, combined with the economical three-phase transmission scheme, allow a service drop to be longer than in the North American system and allow a single drop to service several customers. Commercial and industrial service drops are usually much larger and more complex, and so a three-phase system is used. In the United States, common services consist of 120Y/208 (three 120V circuits 120° out of phase, with 208V line to line), 240V three phase, and 480V three phase. 575V three phase is common in Canada, and 380–415V or 690V three phase is found in many other countries. Generally, higher voltages are used for heavy industrial loads and lower voltages for commercial applications.

The difference between commercial and residential electrical installations can be quite significant, particularly with large installations. While the electrical needs of a commercial building can be simple, consisting of a few lights for some small structures, they are often quite complex, with transformers and heavy industrial equipment. When electrical or lighting system deficiencies become evident and need attention, they are usually measurable and include power surges, tripped CBs, noisy ballasts, and other more obvious conditions such as inoperative electrical receptacles or lighting fixtures that are frequently discovered or observed during a review of the system. As illustrated in [Figs. 9.21 and 9.22](#), there are a number of typical deficiencies found in both the electrical and the lighting systems.

In commercial buildings, the major load placed on a given electrical system usually comes from the lighting requirements; therefore, the distribution and management of electrical and lighting loads must always be monitored on a regular basis. Lighting management should also be periodically checked because building space uses change and users relocate within the building. It is also highly advisable for the lighting system to be integrated with the electrical system in the facility. Lighting systems are designed to ensure adequate visibility for both the interior

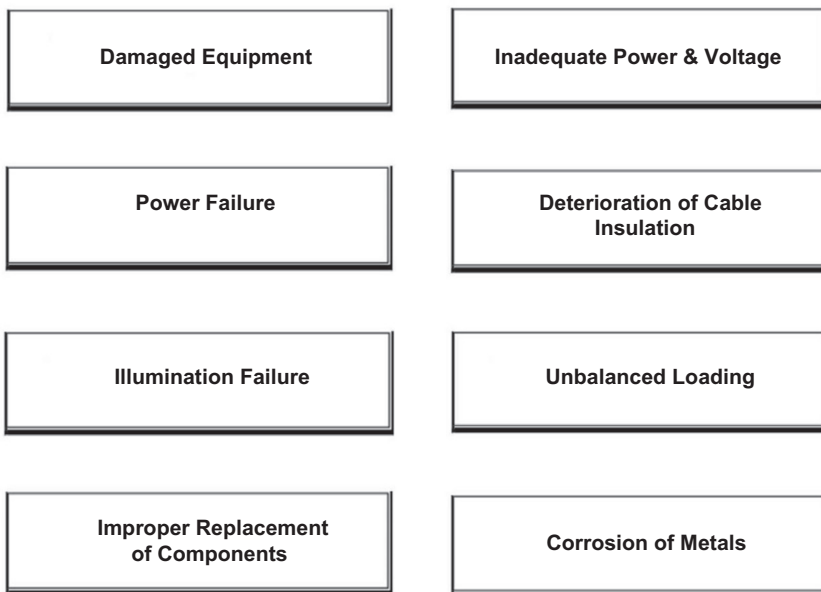

Figure 9.21 Diagram showing typical deficiencies found in electrical systems.

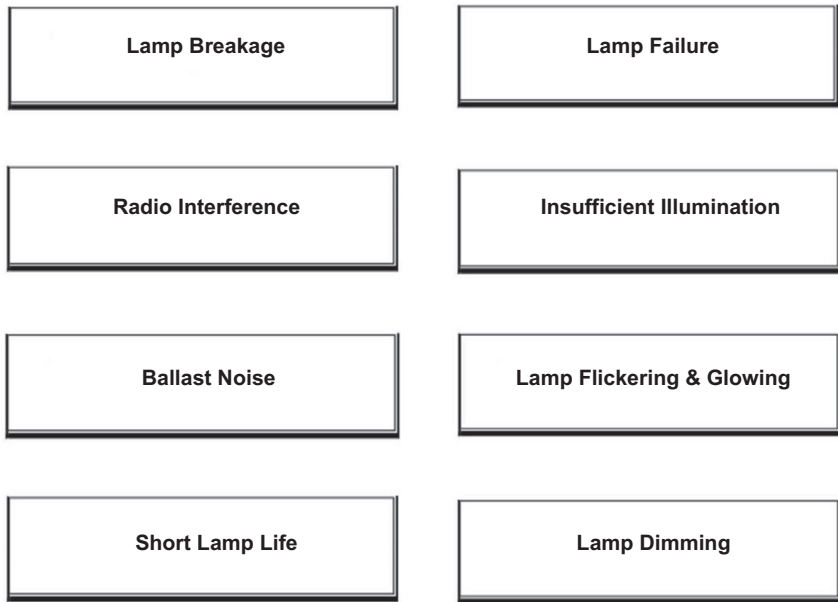

Figure 9.22 Diagram showing typical deficiencies found in lighting systems.

and exterior of a facility and are comprised of an energy source, and distribution elements normally consisting of wiring, and light-emitting equipment.

There are several different electrical codes today being enforced in various jurisdictions throughout the United States. Some of the larger cities, such as New York and Los Angeles, have created and adopted their own electrical codes. The National Electrical Code (NEC) and the National Fire Protection Code (NFPC), published by the National Fire Protection Association (NFPA), cover almost all electrical system components. The NEC is commonly adopted in whole or in part by municipalities. Inspection of the electrical and lighting system should include a determination of general compliance with these codes at the facility. With very large facilities employing complex electrical equipment, it may be necessary to operate it under engineering supervision or alternatively to have a full-time facilities manager.

9.5.1 Understanding Amps, Volts, and Watts

The electrical service in most countries around the world is brought into a building at either 240V or 120V. These numbers are called “nominal,”

meaning that the actual voltage may vary. Most modern buildings receive 240V service, a total achieved by the provision of two individual 120V incoming power lines. Older buildings and electrical services often delivered only 120V. While knowing the available voltage level is important, this information alone is insufficient as it does not indicate the amount of electrical power available inside a building. In order to calculate this we need to know the service voltage at a building, in addition to the service amperage. However, before proceeding it would be prudent to have a basic understanding of some common electrical terms that apply to electrical systems.

Amperage (A or AMP)

This is a unit of electrical current. The Amperage or Amps provided by an electrical service is the flow rate of “electrical current” that is available. Appliances will typically have an Amp rating or if only a wattage is quoted, $\text{Amps} = \text{Wattage} / \text{Voltage}$. Practically speaking, the voltage level provided by an electrical service, combined with the ampacity rating of the service panel, determines the electrical load or capacity. Branch circuit wire sizes and fusing or CBs used to typically set the limit on the total electrical load or the number of electrical devices that can be run at once on a given circuit. Thus, for example, if you have a 100A current flow rate in place, you may be able to run approximately 10 amp electric heaters simultaneously. If you have only 60A available, you will not be able to run more than six such heaters without risking overheating the wiring, tripping a CB, blowing a fuse or causing a fire, which is why it is important to avoid overloading the system.

To be able to determine the amount of electrical service a facility receives the service ampacity and voltage must be known. The safe and proper service amperage available at a property is set by the smallest of the service conductors, the main disconnect fuse or switch, or the rated capacity of the electric panel itself. The main fuse/CB is the only component, which actively limits amperage at a property by shutting off loads drawing more than the main fuse rating. The main breakers or fuses are allowed to have lower overcurrent protection than the capability of the service equipment (panel) and conductors (entrance cable).

Voltage

A Volt (V) can be defined in several ways; often it is defined as the potential difference across a conductor when a current of 1A dissipates 1W of power. Practically speaking, a volt is a measure of the strength of an electrical

source at a given current or amperage level. If we bring 100A into a building at 240V, we have twice as much power available as if we bring in 100A at 120V. However, if we exceed the current rating of a wire it will get hot, risking a fire. This is why fuse devices are employed to limit the current flow on electrical conductors to a safe level and thereby prevent overheating and potential fires. Moreover, as previously mentioned, a “240V” circuit is a nominal rating, which implies that the actual voltage level will vary. In many countries the actual voltage level varies around the nominal delivered “voltage rating” and in fact depending on the quality of electrical power delivered on a particular service, voltage will also vary continuously around its actual rating. Most electrical power systems are prone to slight variations in voltage due to demand or other factors. Generally, this difference is inconsequential, as most appliances are built to tolerate current a certain percentage above or below the rated voltage. However, severe variations in current can damage electrical equipment, which is why installing a voltage stabilizer is always advisable where sensitive electronic equipment is used.

Wattage

In electricity, a watt is a unit of measure of electric power and is equal to current (in amperes) multiplied by voltage (in volts). Most people use a very simple mathematical formula to determine how many watts an electrical circuit can carry or how many watts an electrical device will require: $\text{Watts} = \text{Volts} \times \text{Amps}$. In buildings the unit of electricity consumption measure is the watt hour, which is usually in thousands, called kilowatt hours (kwh). In larger buildings, not only is the total consumption rate measured but also the peak demand as well.

9.5.2 Electrical Components

It is the electrical control system that is used to control a buildings HVAC system. As previously mentioned, modern Building Automated Systems (BAS) can also control indoor and outdoor lighting as well as security, fire alarms, and basically everything else that is electrical in the building. Still, even though electric service is vital to all residential and commercial buildings, it is nevertheless often one of the last components to be installed during the construction process.

Service Connections

Planning the design, construction, and timing of installation of electric service to a construction project should be contemplated from the very

early stages. The service connection equipment basically provides a connection between the power company service and the facility and also measures the amount of electricity a facility uses. From here a meter either feeds a disconnect switch or a main breaker or fuse panel. The connection can be located either overhead or underground. The service connection should be checked for type (i.e., voltage, amperage), and general condition and whether the total power adequately serves the facility's requirements. The equipment should be clean and free from overgrown planting and debris. A detailed discussion of installation requirements of electric service connections is outside our scope.

Switchgear and Switchboards

The function of switching equipment is to control the power supply in the facility and all the services arriving on the site (service drop). This consists of the wires from the main line, a transformer, a meter, and a disconnect switch. The main service switch is the system disconnect for the entire electrical service and is generally used in combination with metering, disconnect switch, protective, and regulating equipment to protect and control motors, generators, transformers, and transmission and distribution lines. The main service switch is the system disconnect for the entire electrical service. To avoid excessive voltage drop and flicker, the distance from the transformer to the meter should not exceed 150 ft. In commercial construction the panel and disconnect should preferably be located outside the building but may be located inside the building if they are accessible from an exterior door.

A switchboard is comprised of one or more panels with various switches and indicators that are used to route electricity and operate circuits. The main switchboard controls and protects the main feeder lines of the system. Switchgear and switchboards should be readily accessible, in good condition, and have protective panels and doors. They should also be checked for evidence of overloading or burn marks. Switchboard covers should not normally be removed.

Switchgears are typically concentrated at points where electrical systems make significant changes in power, current, or routing, such as electrical supply substations and control centers. Switchgear assemblies range in size from smaller, ground-mounted units to large walk-in installations and can be classified as outdoor or indoor units. Commercial and industrial assemblies are usually indoors, while utilities and cogeneration facilities are more likely to have outdoor gear. Manufactured for a variety of functions and power levels, all switchgear conforms to standards set by the Institute of Electrical

and Electronic Engineers (IEEE), the National Electrical Manufacturers Association (NEMA), or the American National Standards Institute (ANSI).

Meters

There are basically two methods of measuring electric consumption in a building. In residential applications, only the total electric consumption is measured. In larger facilities, both the total consumption peak rate demands are measured. This is because large peaks require the utility company to build more power-generating capacity to meet the peak. Commercial services of up to 200 amps single phase may have service panels similar to those found in residences. Larger services may require stand-alone switchboards with one or more meters. In a multiple occupancy building, there may be separate meters for each tenant or common metering.

Panelboards

Electrical panelboards and their cabinets house an assembly of CBs and control and protect the branch circuits. From the panelboards the power generation can be monitored and the power generated can be distributed. In addition to control and protect the branch circuits, panelboards are designed to providing a central distributing point for the branch circuits for a building, a floor, or part of a floor. Each breaker serves a single circuit, and the overload protection is based on the size and current-carrying capacity of the wiring in that circuit. A building may have a number of panelboards and a main panel with a disconnect switch for the entire building. The following are examples of lighting panel types:

- Plug-in CBs (1-pole)
- Bolt-on CBs (1-pole, 2-pole, 3-pole)
- Fusible switch.

To estimate the electric service panel ampacity, Evidence of a tag (normally paper) or embossed rating on fuse pull outs on the panel itself and often includes the amperage rating of the panel. This information is usually present in newer panels on a panel side or on the panel cover. Actual dimensions of an electric panel are not a reliable determinant of ampacity. For example, many larger panels can be fitted with a variety of bus bar and main switch assemblies of varying ampacity.

Aluminum Wiring

During the 1970s, aluminum (instead of copper) wiring became quite popular and used extensively. Since that time however, aluminum-wired connections have been implicated in a number of house fires, and most

jurisdictions no longer permit their use in new installations (<http://www.inspect-ny.com/aluminum/ja-54.jpg>). Aluminum-wired connections have been found to have a very high probability of overheating compared with copper-wired connections and were therefore a potential fire hazard. Over the years, a large number of connection burnouts have occurred in aluminum-wired homes, and according to the U.S. Consumer Product Safety Commission, many fires have resulted, some involving injury and death. The main problem with aluminum wiring is a phenomenon known as “cold creep.” When aluminum wiring warms up, it expands, and when it cools down, it contracts. However, unlike copper, when aluminum goes through a number of warm/cool cycles it begins to lose some of its tightness. To add to the problem, aluminum oxidizes, or corrodes when in contact with certain types of metal, so the resistance of the connection increases. This causes it to heat up and corrode/oxidize still more and until eventually the wire may start getting very hot and melt the insulation or fixture it is attached to, and possibly even cause a fire without ever tripping the CB.

Although aluminum wire “alloys” were introduced in the early 1970s, this did not adequately address most of the connection failure problems. Aluminum wiring is still permitted and used for certain applications, including residential service entrance wiring and single-purpose higher amperage circuits such as 240V air conditioning or electric range circuits. Although the fire risk from single purpose circuits is much less than for branch circuits, field reports indicate that these connections remain a potential fire hazard.

A simple method of identifying aluminum wiring is to examine the wire sheathing for the word aluminum. If you cannot find the word aluminum embossed in the wire sheathing, then look for silver-colored wire instead of the copper-colored wire used in modern wiring. Without opening any electrical panels or other devices, it is possible to still look for printed or embossed letters on the plastic wire jacket where wiring is visible at the electric panel. Some aluminum wire has the word “Aluminum” or a specific brand name such as “Kaiser,” “Alcan,” “Aluminum,” or “AL/2” plainly marked on the plastic wire jacket. Some white-colored plastic wire jackets are inked in red; others have embossed letters without ink and are hard to read. Shining a light along the wire may make it easier to identify. Of note, the fact that no aluminum wiring was evident in the panel does not necessarily mean that none is present. Aluminum may have been used for part of circuits or for some but not other circuits in the building.

Service Outlets and Receptacles

Service outlets include convenience receptacles, motors, lights, and appliances. Receptacles are commonly known as *outlets* or sometimes erroneously as wall plugs (a plug is what actually goes into the outlet). It is preferable for outlets to be three-prong where the third prong is grounded. For large spaces or areas, all of the outlets should not be on the same circuit so that when a fuse or CB trips due to an overload, the space will not be plunged into complete darkness. Important specifications for electrical receptacles include number of poles and grounding method. Today's electrical receptacles have a variety of features. Some devices include surge protection against mild to moderate spikes or peaks in the electrical supply, while others have a locking mechanism or a power light.

Grounding

The grounding of a service to earth is basically a safety precaution and is necessary mainly to protect against lightning strikes or other high-voltage line strikes. It is important to conform to the National Electric Code (NEC) when considering grounding. The NEC is the benchmark for safe electrical design, installation, and inspection to protect people and property from electrical hazards. Official document scope is Adopted in all 50 states. The NEC addresses the installation of electrical conductors, equipment, and raceways; signaling and communications conductors, equipment, and raceways; and optical fiber cables and raceways in commercial, residential, and industrial occupancies.

Earth grounding in a commercial building might be to a grounding rod inside a switchboard, to a steel cold water pipe in the plumbing system, or to the steel frame of a building. Other methods of grounding are also used depending on the equipment or system to be grounded. Grounding also drains the static charges away as quickly as they are produced. Ground wires are typically covered with green insulation or sometimes may be without cover.

Motors, Switches, and Controls

These are devices that convert any form of energy into mechanical energy, especially an internal combustion engine or an arrangement of coils and magnets that converts electric current into mechanical power. Basically, there are four types of motors in general use, they are as follows:

- The *DC Motor* is a rotating electric machine designed to operate from a direct voltage source. It is used for small-scale applications and for elevators, where continuous and smooth acceleration to a high speed is important.

- *Stepper/Switched Reluctance (SR) Motors* are brushless, synchronous electric motors that can divide a full rotation into a large number of steps. The motor's position can be controlled precisely, without any feedback mechanism. Stepper motors are basically similar to SR Motors—in fact the latter are very large stepping motors with a reduced pole count and generally are closed-loop commutated. The main advantage of stepper motors is that they can achieve accurate position control without the requirement for position feedback. Stepper motors operate differently from normal DC motors, which rotate when voltage is applied to their terminals.
- The most common and simple industrial motor is the three-phase *AC Induction Motor*. This type can be either three-phase AC or single-phase AC. The three-phase AC induction motor is a rotating electric machine designed to operate from a three-phase source of alternating voltage and usually applies to larger motors. These motors are characterized by extreme reliability and remain constant in rpm, unless heavily overloaded. The single-phase motor is a rotating machine that has both main and auxiliary windings and a squirrel cage rotor.
- The fourth type of motor in general use is the *Universal Motor*, which is a rotating electric machine similar to a DC motor but designed to operate either from direct current or single-phase alternating current, and which varies in speed based on the load. The universal motor is usually found in mixers, hand drills, and similar appliances. Motors should always be protected against overload by *thermal relays*, which shut off the power when any part of the motor or housing overheats.

Switches and Controls

Switches and controls are devices that direct the flow of power service to the electrical equipment. Safety switches are installed in locations where service cutoff is available in case of emergencies. These include toggle switches, dials, and levers. The quality of control switches is based on the gold or silver plating, which determines life cycles. Today, most vendors now also offer customized rotary switches based on the specific needs of end users.

Emergency Power

For certain facilities, it is an absolute necessity to have standby power with which to ensure continued electrical service when a shutdown of the standard power service takes place. Emergency power is required for life support systems, fire and life safety circuits, elevators, exit, and emergency lighting.

Facilities which require full operation during emergencies or disasters, such as hospitals and shelters, always have backup power. Computer facilities, to ensure continued storage and survival of the data, also commonly have emergency power. For major equipment, a diesel engine generator with an automatic starting switch and an automatic transfer switch is often provided for emergency power (Fig. 9.23) while for lighting, battery units are installed. The typical AC power frequency in the United States is 60 cycles per second or 60 Hz, whereas in Europe, 50 Hz is the standard.

However, for emergency power to function properly, it is imperative to ensure that the interconnected systems are also functioning. This includes but not limited to ancillary equipment such as starters, fuel and lubrication pumps, and cooling equipment. Likewise, distribution systems such as switchgear, panels, controllers, branch circuits, feeders, transfer switches, transformers, and so forth also need to function. Failure of any component in the emergency power system can prevent its proper operation. In regions where there is the possibility of earthquakes, all components of the system must be designed and braced for seismic loads.

Transformers

The US Department of Energy has recently mandated that effective January 1, 2016; distribution transformers manufactured for the United States must meet the new, more stringent Energy Efficiency Standard (DOE, 2016) as part of the Energy Policy and Conservation Act (EPCA). Understanding the



Figure 9.23 Photo of an Amtrak generator for emergency backup power inside a building.

new standard and its impact will help ensure a seamless transition to compliant transformer designs. Transformers are devices that convert an alternating current (A/C) circuit of a certain voltage to a higher or lower value, without change of frequency, by electromagnetic induction. Transformers are used to step up voltage (called “step up” transformers) in order to transmit power over long distances without excessive losses and subsequently step down voltage (called “step down” transformers) to more useable levels. While a transformer changes the voltage of an alternating current (AC) in a circuit to a higher or lower value, it has practically no effect on the total power in the circuit.

The DOE defines a Distribution Transformer as:

- Having input voltage of 34.5 kV or less
- Having an output voltage of 600V or less
- Being rated for operation at a frequency of 60 Hz
- Featuring a capacity range for dry-type transformers of 15–2500 kVA
- Being either a single- or three-phase transformer.

The full standard can be found in the Code of Federal Regulations.

Transformers come in two distinct types: They can be wet or dry type. There are also subcategories of each main type. Lower voltage types are dry, and typically noise generating, with minimal requirements for insulation and avenues for ventilation of heat generated by voltage changes. For wet or liquid-filled transformers, the cooling medium can be conventional mineral oil. Some wet-type transformers use less flammable liquids, such as high fire point hydrocarbons and silicones. Wet transformers are typically more efficient than dry types and usually have a longer life expectancy. There are some drawbacks, however. For example, fire prevention is more important with liquid-type units because the liquid cooling medium used may catch fire (although dry-type transformers are also susceptible) or even explode. Wet-type transformers typically contain a type of fire-resistive fluid or mineral oil such as PCBs, and, depending on the application, wet transformers may require a containment trough for protection against possible leaks of the fluid, which is why they are preferred predominantly when placed outdoors.

For lower voltage type indoor-installed distribution transformers of 600V and below the dry-type transformer is preferred even though they have minimal requirements for insulation and avenues for ventilation of heat generated by voltage changes. Dry-type transformers come in enclosures that have louvers or are sealed. Location of transformers should be carefully considered and there should be clear access surrounding exterior

transformers and adequate ventilation and access for interior transformers, which should be inside a fireproof vault. On-site transformers in parking lots may require bollards or other protection (Fig. 9.24). Transformers should be analyzed for PCB's and their registration number noted. In addition, transformers tend to make a certain amount of noise (hum), which should be addressed if it causes irritation.

9.5.3 Lighting Systems

The main function of good lighting, whether natural or artificial, is to provide visibility and allow us to see so that we can perform our tasks, and thus making a space useable. Different artificial sources produce different kinds of light, and vary significantly in their efficiency, which is the calculated lumen output per watt input. Another primary objective must be to minimize energy usage while achieving the visibility, quality, and aesthetic objectives. The quality and quantity of lighting affect the ambience, security, and function of a facility as well as the performance of its employees. Divergent artificial sources produce different kinds of light, and vary significantly in their efficiency, which is the calculated lumen output per watt input. Regrettably, US lighting design does not readily translate overseas—not when different regions have their own voltage, product standards, construction methods, and conceptions about what light is meant to achieve. However, this is facilitated by increased integration of the lighting systems which simplifies electrical distribution and control systems design. In fact,



Figure 9.24 Illustration of a Transformer located outside a facility and protected by bollards.

energy efficiency is the main theme of the recent (March 2016—Frankfurt, Germany) Light + Building exhibition which is held every 2 years is energy efficiency. Light + Building is the platform when it comes to the latest innovations around lighting and building automation. It is the world's leading trade fair for architecture and technology; the exhibition period is firmly rooted in the calendars of the visitors and exhibitors (210,000 visitors and 2400 exhibitors) to see innovations and trends. Moreover, the popularity of the exhibition is clearly reflected by the number of visitors and exhibitors.

Interior Lighting

Because lighting typically accounts for a significant percentage of the annual commercial business and residential electric bills, it is important to understand the relationship between a source of light, the surfaces that reflect light, and how we see light, and the need to have a common comprehensive lighting language. It goes without saying that without a light source we cannot see, and without surfaces to reflect light, there is nothing to see. Advances in lighting technology can make significant reductions in the amount of money that is spent for lighting a facility. More important, interior lighting should meet minimum illumination levels (Table 9.3). It is important to determine the amount of light required for the activity that will take place in a space. Typically, the illuminance levels needed for visibility and perception increases with high accuracy activities and as the size of details decreases, as contrast between details and their backgrounds is reduced, and as task reflectance is reduced. However, interior lighting must not exceed allowed power limits. Interior lighting includes all permanently

Table 9.3 Table of recommended illumination levels for various functions

Area	Foot-candles
Building surrounds	1
Parking area	5
Exterior entrance	5
Exterior shipping area	20
Exterior loading platforms	20
Office corridors and stairways	20
Elevators and escalators	20
Reception rooms	30
Reading or writing areas	70
General office work areas	100
Accounting/bookkeeping areas	150
Detailed drafting areas	200

installed general and task lighting shown on the plans but does not include specialized lighting for medical, dental, or research purposes and display lighting for exhibits in galleries, monuments, and museums. For this reason, there are many types of interior lighting systems that address these needs and enable us to make full use of a facility around the clock. The most common categories are as follows:

- **Fluorescent Lamps:** This type of fixture has long been preferable to incandescent lighting, in terms of energy efficiency. Fluorescent lighting is far more efficient than incandescent bulbs and has an average life of 10–20 times longer (fluorescent lamps last up to 20,000 h of use), and use roughly one-third as much electricity as incandescent bulbs with comparable output. Compact fluorescent lamps (CFLs) are similar in operation to standard fluorescent lamps but are manufactured to produce colors similar to incandescent lamps. New developments with fluorescent technology, including the high-efficacy T-5, T-8, and T-10 lamps, have pushed the energy efficiency envelope further. Recently, attention has also been paid to the mercury content of fluorescents and the consequences of mercury release into the environment. As with all resource use and pollution issues, reduction is the best way to limit the problem. Even with low-mercury lamps, however, recycling of old lamps remains a high priority.

A fluorescent fixture typically consists of the lamp and associated *ballast*, which controls the voltage and the current to the lamp. Replacing standard incandescent light bulbs with CFLs will reportedly slash electrical consumption in homes and offices where incandescent lighting is widely used. By reducing the amount of electricity used, corresponding emissions of associated carbon dioxide, sulfur dioxide, and nitrous oxide are reduced. CFL technology continues to develop and evolve and is now capable of replacing most of the light fixtures that were originally designed for incandescent light bulbs.

Francis Rubinstein, a scientist and energy-efficiency lighting expert at LBNL's Environmental Energy Technologies Division, believes that fluorescent lighting will continue to dominate the general lighting market and that, in the near-term future, solid-state LED and fluorescent lighting will coexist in hybrid systems—in combination with advanced lighting controls, achieving vast improvements in light efficiency.

- **Incandescent Lamps:** Incandescent lamps have relatively short lives (typically 1000–2000 h of use) and are the least efficient of common light sources. In fact, only about 15% of the energy they use comes out

as light and the rest becomes heat. Nevertheless, remain popular because they produce a pleasant color that is similar to natural sunlight and they are the least expensive to buy. Incandescent lamps come in various shapes and sizes with different characteristics. The most common incandescent outdoor lighting options are metal halide and high-pressure sodium (HPS). Environmental issues include lamp efficacy (lumens per watt), luminaire efficiency, controllability of the light source, potential for PV power, and control of light pollution. To control light pollution, full cutoff luminaires should be specified. It also makes very good sense to use whenever possible environmentally friendly, commercial outdoor lighting systems. For example, Energy Star lights consume only about 20% of the energy consumed by traditional lighting products, thus providing substantial savings in money spent, energy consumed, and greenhouse gas emissions reduction.

Tungsten halogen lamps are a type of incandescent lamp that has become increasingly popular in recent years. They produce a whiter, more intense light than standard incandescent lamps and are typically used for decorative, display or accent lighting. They are about twice as efficient as regular incandescent lamps and last two to four times longer than a typical incandescent lamp.

- **High-Intensity Discharge (HID):** Wikipedia defines HID lamps as “a type of electrical gas-discharge lamp which produces light by means of an electric arc between tungsten electrodes housed inside a translucent or transparent fused quartz or fused alumina arc tube.” This category of high-output light source consists of a lamp within a lamp that runs at a very high voltage. There are basically four types of HID lamps: (1) HPS lamp, (2) Mercury vapor lamps, (3) Metal halide gas, (4) Low-pressure sodium lamps. HID lights require ballasts for proper lamp operation (similar to fluorescent lights). The efficiency of HID sources varies widely from mercury vapor, with a low efficiency—almost as low as incandescent, to low-pressure sodium which is an extremely efficient light source. Color rendering also varies widely from the bluish cast of mercury vapor lamps to the distinctly yellow light of low-pressure sodium.
- **Fiber Optics:** This is an up and coming technology, providing an alternative that is superior to conventional interior and exterior lighting systems. The technology possesses enormous information-carrying capacity, is low cost, and is immune from many of the disturbances that often afflict electrical wires and wireless communication systems. Fiber optics first emerged in the United States during the 1980s as a way

to transmit data far more effectively than other communication systems. Since then researchers have been able to radically improve the efficiency by conveying several data streams over one cable using diverse frequencies.

Fiber optics technology is based on the use of hair-thin, transparent fibers to transmit light or infrared signals. The fibers are flexible and consist of a core of optically transparent glass or plastic, surrounded by a glass or plastic cladding that reflects the light signals back into the core. Light signals can be modulated to carry almost any other sort of signal, including sounds, electrical signals, and computer data, and a single fiber can carry hundreds of such signals simultaneously, literally at the speed of light. The superiority of optical fibers for carrying information from one location to another is leading to their rapidly replacing many older technologies. A typical fiber optic lighting system can be broken down into two basic components: a light source, which generates the light, and the fiber optics, which will deliver the light.

Although fiber optic lighting offers unique flexibility compared to conventional lighting, it does have its limitations. Areas of high ambient light should be avoided as they tend to “wash out” the color. However, often fiber optics can be installed in areas not accessible to conventional lighting. Good ventilation is very necessary for all illuminators. Light-colored reflective surfaces are preferable for end light or sidelight applications. Dark surfaces absorb light and should only be used to provide contrast. Typical applications include cove lighting, walkway lighting, and entertainment illumination (Fig. 9.25). One cannot overemphasize the crucial role that optical fibers played and continue to play in making possible the extraordinary growth in worldwide communications that has occurred over the last 2–3 decades, and which is vital in enabling the proliferating use of the Internet and the creation of the “Information Age.” In fact fiber optics systems were even used aboard the NASA space shuttle Endeavor during its February 2000 mission.

It is a well-known fact that all electric light sources experience lumen depreciation and thus the useful life of a lighting installation becomes progressively less efficient during its operation due to dirt accumulation on the surface and aging of the equipment. The rate of reduction is influenced by the equipment choice and the environmental and operating conditions. In lighting scheme design we must take account of this deficiency by the use of a maintenance factor and plan suitable maintenance schedules to limit the decay.



Figure 9.25 Photo showing glass block walls—optical fiber interior. *Source: Lumenyte International Corp.*

Exterior Lighting Systems

It is generally necessary to have adequate outdoor lighting around buildings and there are many innovative, energy-efficient lighting solutions for outdoor applications. The adequacy of outdoor lighting is an important factor in maintaining good security in parking lots and other outdoor areas. The inadequacy of exterior lighting has been the basis of many lawsuits alleging that the facility owner was negligent in providing a proper level of security. In older buildings it is likely that the outdoor security lighting is inadequate, largely because for many years, lighting in parking lots and other outdoor areas was a low priority for lighting designers. Exterior lighting should be carefully designed and sufficient thought given to its placement, intensity, timing, duration, and color and should meet the requirements of The Illuminating Engineering Society of North America (IES or IESNA). Outdoor lighting used to illuminate statues, signs, flags, or other objects mounted on a pole, pedestal or platform, spotlighting or floodlighting used for architectural or landscape purposes, must use full cutoff or directionally shielded lighting fixtures that are aimed and controlled so that the directed light is substantially confined to the object intended to be illuminated. Facility evaluations are often required to identify inadequate exterior lighting conditions. Lighting controls are necessary to ensure that exterior light is available only when required. Full cutoff lighting fixtures are required for all outdoor walkway, parking lot, canopy and building/wall-mounted lighting,

and all lighting fixtures located within those portions of open-sided parking structures that are above ground. An open-sided parking structure is a parking structure which contains exterior walls that are not fully enclosed between the floor and ceiling.

Many cities and towns around the country have enacted ordinances concerning “light pollution.” These ordinances often set limits on the amount and type of light that can be used for outdoor parking lot lighting. It is important to consult local jurisdiction before making any changes in the lighting system. Moreover, to meet code requirements, automatic controls are typically required for all exterior lights. The control may be a directional photocell, an astronomical time switch, or a BAS with astronomical time switch capabilities. The control should automatically turn off exterior lighting when daylight is available. Lights in parking garages, tunnels, and other large covered areas that are required to be on during daylight hours are exempt from this requirement. Incandescent and HID is the most common type for exterior lighting. Illumination levels should be adequate and in good condition. The growth of trees and other types of landscaping provides another challenge that may have to be addressed. It can have a significant impact on outdoor lighting. Often, a well-designed lighting system becomes ineffective due to tree grow to a point where large portions of the light are blocked out. This can be addressed by arranging to have trees and landscaping regularly trimmed so that the lighting system is not adversely affected.

Emergency Lighting Systems

Emergency power systems are intended to serve three primary functions:

- Provide a safe environment for building occupants in the event of a power loss.
- Protect equipment and property from damage.
- Provide continuity of operations.

In the event of an emergency, where an electric failure occurs, it can cut power to a main lighting system. Emergency lighting systems are arranged to provide continuity of this very essential service, and which are comprised of lighting fixtures connected to the 110-V power source.

NFPA 101 2006 stipulates that Emergency illumination (when required) must be provided for a minimum period of 1.5 h to compensate for the possible failure of normal lighting. NFPA also requires emergency lighting to be arranged to provide initial illumination of not less than an average of one foot-candle and a minimum at any point of 0.1 foot-candle measured along the path of egress at floor level. In all cases an emergency lighting system

must be designed to provide illumination automatically in the event of any interruption of normal lighting (NFPA 101 2006 7.9.2.3). Emergency lighting and LED signs typically use relatively small amounts of energy and have a long life expectancy. Although LED fixtures may cost more than incandescent fixtures, reduced energy costs and labor savings will often quickly make up the difference.

For most facilities, having an emergency lighting system in place is necessary in the event of a power failure or other emergency; emergency lighting in a facility enables the occupants to exit safely. Emergency lighting can consist of individual battery units placed in all corridors, stairwells, lobbies, and key locations that may require sufficient lighting for building user exiting, in interior and some exterior exitways. These batteries are continuously recharged while power is on, and which take over when power is lost. Also, the advantages of this type of emergency lighting system are flexibility; technicians can relocate the systems effortlessly to accommodate any changes in the building's layout. Since each lamp has its own power source, if one goes out, the others will remain in operation. Alternatively, the lighting can be powered by a central battery unit. Fluorescent lamps will require some method of power conversion as batteries are typically 12 volt.

9.5.4 Harmonics

Loads connected to electricity supply systems may be broadly categorized as either linear or nonlinear. There was a time when almost all electrical loads were linear—those that were not made up such a small portion of the total that they had little effect on electrical system operation. That all changed, however, with the arrival of the solid-state electronic revolution. Today, we are immersed in an environment rich in nonlinear loads, including:

- A variety of solid state devices, such as desktop computers,
- UPS equipment,
- Industrial equipment (welding machines, arc furnaces, induction furnaces, rectifiers)
- Office equipment (PCs, photocopy machines, fax machines, and so forth)
- Inverters
- Variable speed drives for asynchronous and DC motors
- Induction motors
- Household appliances (television sets, microwave ovens, fluorescent lighting, and so forth).

Operation of these devices represents a double-edged sword. While they provide greater efficiency, they can also cause serious consequences to power distribution systems—by creating high levels of harmonic distortion. In reality, total harmonic distortion is hardly perceptible to the human ear, and even though the voltage distortion caused by the increasing penetration of nonlinear loads is often accommodated without serious consequences, power quality is compromised in other cases unless steps are taken to address this phenomenon.

Although most of the loads connected to the electricity supply system draw power that is a linear (or near linear) function of the voltage and current supplied to it, these linear loads do not normally cause disturbance or adversely impact other users of the supply system. Some types of loads however cause a distortion of the supply voltage/current waveform due to their nonlinear impedance. Harmonic distortion can surface in electric supply systems through the presence of nonlinear loads of sufficient size and quantity. The severity of problems depends upon the local and regional supply characteristics, the size of the loads, the quantity of these loads, and how the loads interact with each other. Utility companies are clearly concerned about emerging problems caused by increasing concentrations of nonlinear loads resulting from the growing proliferation of electronic equipment, particularly computers and their AC to DC power supply converters, and electronic controllers. By taking a closer look at linear and nonlinear loads, we can get a better understanding of the hows and whys of this distortion.

Harmonic Reduction

Reducing harmonic voltage and current distortion from nonlinear distribution loads such as adjustable frequency drives (AFDs) can be achieved through use of several basic approaches. However, in the presence of excessive harmonic distortion, it is highly recommended to bring in a specialized consultant to correct the issue. Some of the methods used by harmonic specialists to reduce harmonic distortion may include the use of a DC choke, line reactors, 12-pulse converters, 12-pulse distribution, harmonic trap filters, broadband filters, and active filters. Whatever approach is applied to achieve reduction, it must meet the guidelines of the IEEE. Furthermore, control of lower order powerline harmonic emissions from nonlinear loads is rapidly becoming one of the most severe and complex electrical challenges facing the electrical industry, and one that requires close cooperation between utilities, equipment manufacturers, premises owners, and end users if it is to be addressed.



9.6 SOLAR ENERGY SYSTEMS

Solar is one of the fastest growing energy sources in the United States. Solar power which at its simplest is the raw energy created by the sun's rays, and can be either active or passive. Solar technologies use the sun's energy and light to provide heat, light, hot water, electricity, and even cooling, for homes, businesses, and industry. In fact, many believe that passive and active solar energy is the energy source of the future, for nowhere on the planet can we find any other energy source as powerful and without sacrificing our natural resources and environment.

9.6.1 Solar Options

There are many solar options today that can replace much of today's regular energy needs, saving money, and benefiting the environment by cutting down on the use of fossil fuels. New technologies continue to be developed at such a rapid pace while at the same time being used to help us harness this enormous natural energy asset.

Active Solar Energy Systems

Solar electric systems are environmentally friendly because they do not generate emissions of greenhouse gasses or other pollutants, thereby do not have an adverse impact on global climate. Solar electric systems have proven to be reliable and are pollution-free. They make use of our most important renewable source of energy—the sun. And photovoltaic (PV) systems for homes and businesses are becoming more accessible and affordable.

Solar Photovoltaics

PV materials convert sunlight into useful, clean electricity. By adding PV to your home or office, you can generate renewable energy, reduce your own environmental impact, enjoy protection from rising utility costs, and reduce greenhouse gas emissions. Electricity is only one of many uses for solar energy. The sun of course is essential to your garden, and it can heat water very cost-effectively, but the most fundamental use of solar energy is in overall building design. Good design uses solar radiation to passively and/or actively heat your building and to help keep it cool. Solar energy is also increasingly being used for street lighting (Fig. 9.26). Building integrated photovoltaic systems (BIPVs) offer additional design options, allowing electricity to be generated by windows, shades and awnings, roofing shingles,



Figure 9.26 Example of solar power LED street lighting with automatic on–off, lasts for four to five nights after fully charged. *Source: Hankey Asia Ltd.*

and PV-laminated metal roofing, for example. BIPV options can be used in retrofits or new construction.

As previously stated, solar energy is a renewable resource that is environmentally friendly, and unlike fossil fuels, solar energy is available in abundance and is free, and immune to rising energy prices. The many ways that solar energy can be used include providing heat, lighting, mechanical power, and electricity. It helps minimize the impact of pollution from energy generation which is considered to be the single largest contributor to global warming. Renewable energy could clean the air, stave off global warming, and help eliminate our nation's dependence on fossil fuels from overseas. The recent upsurge in consumer demand for clean renewable energy and the deregulation of the utilities industry have spurred growth in green power—solar, wind, geothermal steam, biomass, and small-scale hydroelectric sources of

power. This energy demand is further being served by the emergence of small commercial solar power plants around the country.

For decades, solar technologies in the United States and around the world have used the sun's energy and light to provide heat, light, hot water, electricity, and even cooling, for homes, businesses, and industry. The types of renewable technologies available for a particular facility depend largely on the application and what sort of energy is required, as well as a building's design and access to the renewable energy source. Building facilities can use renewable energy for space heating, water heating, air conditioning, lighting, and refrigeration. Commercial facilities include assembly and meeting spaces, educational facilities, food sales, food service, health care, lodging, stores and service businesses, offices, and warehouses.

In the LEED rating system, the on-site renewable energy credits are not always easily achieved, particularly in urban locations. Essentially, you need to generate 2.5–7% of the buildings electricity from wind, water, or solar energy, which due to the many site constraints in a city environment, leaves us with little more than solar energy to focus on.

9.6.2 Solar Electric System Basics

Solar electric systems, also known as PV systems, convert sunlight into electricity. When interconnected solar cells convert sunlight directly into electricity, they form a solar panel or “module,” and several modules connected together electrically form an array. Most people picture a solar electric system as simply the solar array, but a complete system consists of several other components. The working of a solar collector is very simple (Fig. 9.27). The energy in sunlight takes the form of electromagnetic radiation from the infrared (long) to the ultraviolet (short) wavelengths. This radiation from the sun heats a liquid which goes to a hot water tank. The liquid heats the water and flows back to the solar collector. The solar energy that strikes the earth's surface at any particular time largely depends on weather conditions, as well as location and orientation of the surface, but overall, it averages approximately 1000 watts per 10 sq. ft. (equivalent to one square meter) under clear skies with the surface directly perpendicular to the sun's rays. This solar thermal heat is able to provide hot water for an entire family during the summer. The collector size needed per person is just over 16 square feet (1.5 m^2). An average family of four people therefore needs a collector of about 65 sq. ft. (6 m^2). The most common component equipment generally used in on-grid and off-grid solar electric systems is listed below, although systems vary and not all equipment is necessary for every system

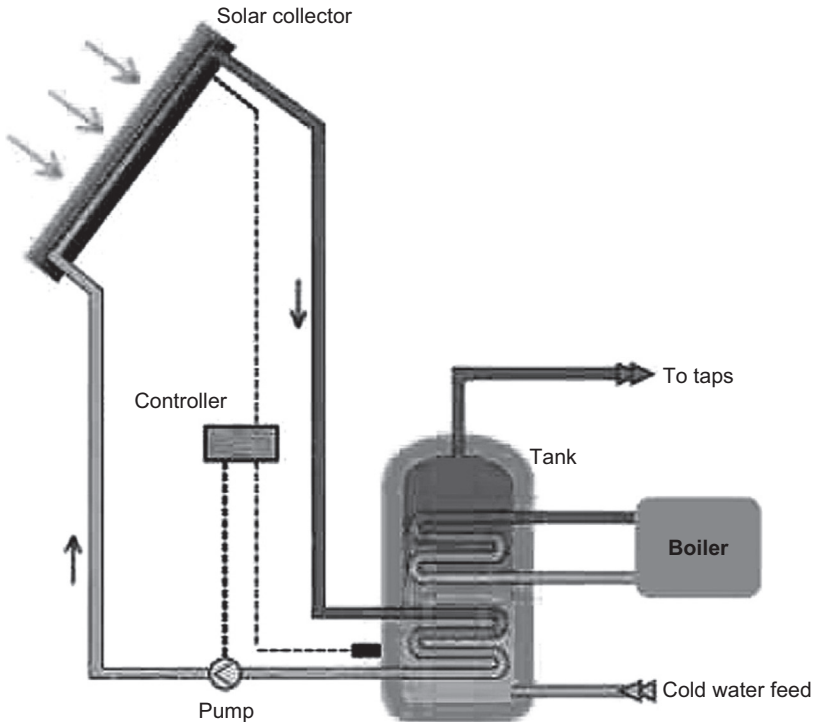

Figure 9.27 Diagram of how a solar thermal collector works.

type. Indeed, understanding the basic components of PV systems and how they function is not particularly difficult.

Solar Electric Panels: PV is the technical word for solar panels that create electricity, and PV material, most commonly utilizing highly purified silicon, converts sunlight directly into electricity. When sunlight strikes the material, electrons are dislodged, creating an electrical current which can be captured and harnessed. The PV materials can consist of several individual solar cells or a single thin layer, which make up a larger solar panel. Panels are usually mounted on either a stationary rack or a tracking rack that follows the movement of the sun (Fig. 9.28), and as they have no moving parts solar electric panels operate silently. Life expectancy of a typical system is 40–50 years. Panels are generally warranted for 20–25 years.

PV has over recent years been making significant inroads as supplementary power for utility customers already served by the electric grid. In fact, grid-connected solar systems now comprise a larger market share than off-grid applications. However, compared to most conventional fuel options,

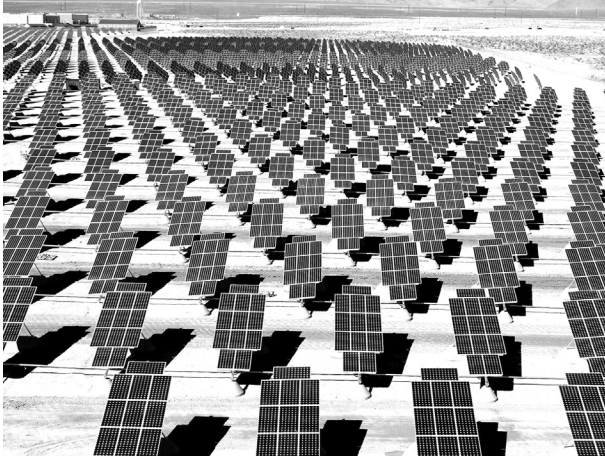

Figure 9.28 Photo taken by Airman first-Class Nadine Barclay of the Nellis Solar Power Plant which is the largest PV power plant in North America. The 70,000 solar panels sit on 140 acres of unused land on the Nellis Air Force Base, Nevada, forming part of a solar PV array that will generate in excess of 25 million kilowatt-hours of electricity annually and supply more than 25% of the power used at the base. *Source: Wikimedia Commons.*

PVs remain a very small percentage of the energy makeup both within the United States and globally. Still, with increasing concerns of global warming, more and more individuals, companies, and communities are choosing PV for a variety of reasons, including environmental, economic, emergency backup, and fuel and risk diversification. The economics of a PV system for a home or business is not just the solar resource, but rather a combination of the solar resource, electricity prices, and local/national tax and other incentives.

One of the critical aspects of solar design is siting. For example, solar panels like full sun, facing within 30° of south and tilting within 30° of the site's latitude. A 1-kW system requires about 80 square feet of solar electric panels. Stationary racks can be roof or pole-mounted. Tracking racks are typically pole-mounted.

Inverter: An *inverter* converts the system's direct current (DC) electricity produced by the PV modules into usable 120Volt alternating current (AC) electricity which is the most common type for powering lights, appliances, and other needs. Grid-tied inverters are utilized to synchronize the electricity they produce with the grid's utility grade AC electricity, allowing the system to feed solar-made electricity to the utility grid. Inverters are typically warranted for 5–10 years.

Array Mounting Rack: Mounting racks provide a secure platform on which to anchor the PV panels, ensuring that they are fixed in place and correctly oriented. Panels can be mounted on a rooftop, on top of a steel pole set in concrete, or at ground level. A PV array is the complete power-generating unit, comprising of one or more solar PV modules (solar panels) that convert sunlight into clean solar electricity. The solar modules need to be mounted facing the sun and avoiding shade for best results. Solar panels generate DC power which can be converted to AC power with an inverter.

Wiring: Selecting the correct size and type of wire will enhance the performance and reliability of the PV system. The size of the wire must be sufficiently large to carry the maximum current expected without undue voltage losses.

Battery Bank: This is used to store solar-produced electricity for evening or emergency backup power. Batteries may be required in locations that have limited access to power lines, as in some remote or rural areas. If batteries are part of the system, a *charge controller* may be required to protect the batteries from being overcharged or drawn down too low. Depending on the current and voltages for certain applications the batteries are wired in series and/or parallel.

Charge Controller: The main function of a charge controller is to protect the battery bank from overcharging. This is achieved by monitoring the battery bank, and when the bank is fully charged, the controller interrupts the flow of electricity from the PV panels. Modern charge controllers usually incorporate maximum power point tracking, which optimizes the PV array's output, thereby increasing the energy it produces.

System Meter: They are used to measure and display several different aspects of a solar electric system's performance and status, tracking how full the battery bank is; how much electricity the solar panels are producing or have produced; and how much electricity is in use.

Array DC Disconnect: The DC disconnect is used to safely interrupt the flow of electricity from the PV array. It is an essential component when system maintenance or troubleshooting is required. The disconnect enclosure houses an electrical switch rated for use in DC circuits, and if required, may also integrate either CBs or fuses.

Main DC Disconnect: Battery-based systems require *Disconnect switches* to allow the power from a solar electric system to be turned off for safety purposes during maintenance or emergencies. It also protects the inverter-to-battery wiring against electrical fires. A disconnect typically consists of a large, DC-rated breaker mounted in a sheet metal enclosure.

AC Breaker Panel: This is the point at which all of a property's electrical wiring meets with the provider of the electricity, whether that is the grid or a solar electric system. The AC breaker panel typically consists of a wall-mounted panel or box that is normally installed in a utility room, basement, garage, or on the exterior of the building. It contains a number of labeled CBs that route electricity to the various spaces throughout a structure. These breakers allow electricity to be disconnected for servicing and also protect the building's wiring against electrical fires.

Kilowatt-Hour Meter: Homes and businesses with a grid-tied solar electric system will often have AC electricity both coming from and going to the electric utility grid. A bidirectional KWH meter is able to simultaneously keep track of how much electricity flows in each direction which tells you how much electricity is being used and how much the solar electric system is producing.

Backup Generator: Off-grid solar electric systems can be sized to provide electricity during cloudy periods when the sun does not shine. But sizing a system to cover a worst-case scenario, like several cloudy weeks during the winter, can result in an unduly large system that will rarely be used to its full capacity. Engine generators can be fueled with biodiesel, petroleum diesel, gasoline, or propane, depending on the design. These generators produce AC electricity that a battery charger (either stand-alone or incorporated into an inverter) converts to DC energy, which is stored in batteries.

9.6.3 Types of Solar Energy Systems

Solar energy technologies use the sun's energy and light to provide heat, light, hot water, electricity, in addition to cooling, for homes, businesses, and industry. Solar electric systems are attracting increasing attention because they are environmentally friendly and do not generate emissions of greenhouse gasses or other pollutants, thereby reducing global climate impacts. Solar panels reflect visible demonstration of concern for the environment, community education, and proactive forward thinking. The three most widely used types of solar electric systems are grid-tied, grid-intertied with battery backup, and off-grid (stand-alone). Each has distinct applications and component needs. However, the majority of households and businesses prefer to choose either a grid-connected or an off-grid system.

Grid-Tied Solar System (alternating current)—also known as on-grid, or grid-intertied PV systems, generates electricity for your home or business and routes the excess power into the electric utility grid. This type of solar electric system does not require storage equipment (i.e., batteries) because it

generates solar electricity and routes it to the electric utility grid, offsetting a home's or business' electrical consumption and, in some instances, even turning the electric meter backward. Living with a grid-connected solar-electric system does not really differ from living with grid power, except that some or all of the electricity used comes from the sun. The crucial issue relative to the PV panels systems is the technical aspects of tying into the electricity grid. Applications of this type require the use of grid-tied inverters that meet the requirements of the utilities.

It is important that the systems do not emit "noise" which can interfere with the reception of equipment (e.g., televisions), switch off in the case of a grid failure, and retain acceptable levels of harmonic distortion (i.e., quality of voltage and current output waveforms). This type of system tends to be an optimum configuration from an economic viewpoint because all the electricity is utilized by the owner during the day and any surplus is exported to the grid. Meanwhile, the cost of storage to meet night-time needs is avoided, because the owner simply draws on the grid in the usual way. Also, with access to the grid, the system does not need to be sized to meet peak loads. This arrangement is termed net metering or net billing. The specific terms of net metering laws and regulations vary from state to state and utility to utility which is why for specific guidelines the local electricity provider or state regulatory agency should be consulted.

The Stand-Alone Grid-Tied Solar System with Battery Backup (alternating current) solar energy system is the same as the grid-tied system except that battery storage (battery bank or generator backup) is added to enable power to be generated even when the electricity grid fails. Incorporating batteries into the system requires more components, is more expensive, and lowers the system's overall efficiency. But for homeowners and businesses that regularly experience utility outages or have critical electrical loads, having a backup energy source is invaluable. The additional cost to the customer can be quantified against the value of knowing that their power supply will not be interrupted.

The Stand-Alone Off-Grid Solar-Electric System without energy storage (direct current) is a configuration (i.e., without any energy storage device) that consists of a PV system whose output is dependent upon the intensity of the sun. In this system, the electricity generated is used immediately and therefore, the application must be capable of work on both direct current (DC) and variable power output. Stand-alone off-grid electric systems are most common in remote locations where there is no utility grid service. These systems operate independently from the grid to provide all the electricity required by a household or small business.

The choice to live off-grid may be because of the prohibitive cost of bringing utility lines to remote locations, the appeal of an independent lifestyle, or the general reliability a solar-electric system provides. However, those who choose to live off-grid often need to make adjustments to when and how they use electricity, to allow them to live and work within the limitations of the system's capabilities.

To meet the greatest power needs in an off-grid location, the PV system may need to be configured with a small diesel generator. This increases the capability of the PV system as it no longer has to be sized to cope with the worst sunlight conditions available during the year. The diesel generator can also provide the backup power, but its use is minimized during the rest of the year of the PV system, to keep fuel and maintenance costs to a minimum.

For any module with a defined peak power, the actual amount of electricity in kilowatt hours (kWh) that it generates will depend primarily on the amount of sunlight it receives. The electrical power output of a PV module is the current that it generates (dependent on its surface area) multiplied by the voltage at which it operates. The larger the module, or the solar array—the number of modules connected together, the more power is generated. A Linear Current Booster can be added to convert excess voltage into amperage to keep a pump running in low light conditions. An LCB can boost pump output by 40% or more. For safety considerations, PV arrays are normally earthed.

With respect to energy production, each kilowatt of unshaded stationary solar electric panels generates about 1200 kW-hours of electricity per year. A 1-kW, dual-axis tracking system will generate about 1600 kWh per year. Power is generated during peak daylight hours. Solar power exhibits a very good peak coincidence with commercial building electrical loads. Dual-axis tracking systems, where the panels follow the sun, will require periodic maintenance as would other systems.

Passive Solar Energy Systems

Passive solar heating and cooling represents an important strategy for displacing traditional energy sources in buildings and is an effective method of heating and cooling through utilization of sunlight. The sun's energy arrives on earth in the primary form of heat and light. To be successful, building designs must carefully balance their energy requirements with the building's site and window orientation. Buildings that are designed to collect, store, and distribute solar energy as heat is referred to as passive solar buildings. Such buildings maximize absorption of sunlight through south-facing windows and use

dark-colored, dense materials in the building to act as thermal mass; the sunlight is stored as solar heat (light colors are less effective for heat storage). But in order to take the best advantage of solar gain, a passive-designed building should have an east–west axis, so that the front of the building is facing south.

The term “passive” indicates that no additional mechanical equipment is used, other than the normal building elements. Solar gains are generally introduced through windows and minimum use is made of pumps or fans to distribute heat or effect cooling. Passive cooling minimizes the effects of solar radiation through shading or generating air flows with convection ventilation.

Correct building orientation, thermal mass, and insulation are specified in conjunction with careful placement of windows and shading. The thermal mass absorbs heat during the day and radiates it back into the space at night. To do this, passive solar techniques make use of building elements such as walls, windows, floors, and roofs, in addition to exterior building elements and landscaping, to control heat generated by solar radiation. Solar heating designs collect and store thermal energy from direct sunlight in a manner that provides energy-efficient space and stable year-round temperatures, yet quiet, and comfortable.

Daylighting design is another solar concept that optimizes the use of natural daylight and contributes greatly to energy efficiency. The quantity and quality of light around us helps determine how well we see, work, and play. Light impacts our health, safety, comfort, morale, and productivity. Whether at home or in the office, it is possible to save energy and still maintain good light quantity and quality. But there are many benefits to using passive solar techniques including simplicity, price, and the design elegance of fulfilling one’s needs with materials at hand. Some of the advantages of passive solar designs include:

- At little or no cost, passive solar design can easily be designed into new construction and can in some cases be retrofitted into existing buildings.
- It pays dividends over the life of the building through reduced or eliminated heating and cooling costs.
- IAQ is improved through elimination of forced air systems.
- Sites with good southern exposure are most suitable.
- Retrofitting is rarely as effective as initially designing for this method.

LEED offers credits in its Indoor Environmental Quality section, Daylight, and Views. The **intent** of the credits appear to be to reduce electric lighting, increase productivity, and provide building occupants with a connection between indoor and outdoor spaces by incorporation of daylight and views into regularly occupied spaces.

LEED Requirements for these credits is to achieve daylight (through computer simulations) in a minimum of 75% or 90% of regularly occupied spaces, and achieve a daylight illuminance level of a minimum of 25 foot-candles and a maximum of 500 foot-candles in a clear sky condition on September 21 at 9.00 a.m. and 3.00 p.m. A combination of side lighting and/or top lighting may be used to achieve the total Daylighting Zone required which is at least 75% of all the regularly occupied spaces. Sunlight redirection and/or glare control devices may be provided to ensure daylight effectiveness. The provision of daylight redirection and/or glare control devices to avoid high-contrast situations should be provided to avoid impeding of visual tasks. Exceptions for areas where tasks would be hindered by daylight will be considered on their merits. It should be stressed that the USGBC Reference Guide or Website should be consulted for the latest updated requirements including possible exemplary performance credits.



9.7 FEDERAL TAX CREDITS FOR ENERGY EFFICIENCY

(Source: ENERGY STAR—U.S. Environmental Protection Agency—U.S. Department of Energy).

Tax Credits for Consumers: There are many tax credits and incentives available for energy efficiency. For example, one is 10% of cost up to \$500 or a specific amount from \$50–\$300. This expires on December 31, 2016. It must be for an existing home and your principal residence. New construction and rentals do not qualify. This is applicable for:

- Windows, Doors, and Skylights
- Insulation
- Roofs (Metal and Asphalt)
- HVAC
- Water Heaters (nonsolar)
- Biomass Stoves
- Air Source Heat Pumps.

Tax credits are available at 30% of the cost, with no upper limit through 2016 (for existing homes and new construction). Second homes qualify but Rentals do not qualify. This is applicable for:

- GHPs
- Solar Energy Systems
- Small Wind Turbines (Residential).

Tax credits are available at 30% of the cost up to \$500 per 0.5 kW of power capacity through 2016 for existing homes and new construction.

Must be principal residence; Rentals and second homes **do not** qualify. This is applicable for:

- Fuel Cells
- Microturbine Systems.

Tax Deductions for Commercial Buildings: A tax deduction of up to \$1.80 per square foot is available to owners or designers of new or existing commercial buildings that save at least 50% of the heating and cooling energy of a building that meets ASHRAE Standard 90.1-2001. Partial deductions of up to \$60 per square foot can be taken for measures affecting any one of three building systems: the building envelope, lighting, or heating and cooling systems. These tax deductions are available for systems placed in service from January 1, 2006 to December 31, 2013. In addition, there are many other tax credits for efficient cars, home builders, home improvements, and so forth.



9.8 FIRE SUPPRESSION SYSTEMS

According to the Fire Suppression Systems Association (FSSA) 43% of businesses closed by fire never reopen and another 29% fail within 3 years. These are stark statistics. Fire suppression systems are used in conjunction with smoke detectors and fire alarm systems to improve and increase public safety. Suppression systems are governed by the codes under the NFPA 13 handbook and include Fire sprinkler systems (wet, dry, preaction, and deluge), gaseous agents, and wet/dry chemical agents. When planning for fire protection, an integrated approach is needed in which system designers analyze the building's components as a total package. To achieve an optimum symbiosis between these components, an experienced system designer, such as a fire-protection engineer, should be involved in the very early stages of the planning and design process. With the increasing number of high rise, high-performance buildings being built both nationwide and globally, the planning for fire protection has taken on a real urgency. Fire suppression design requires an integrated approach in which system designers need to analyze building components as a total package. As with other aspects of sustainable design, to achieve the most beneficial symbiosis between these components, an experienced system designer, such as a fire-protection engineer, should be involved early in the planning and design process and should be an integral part of the project team. Moreover, moving forward, we should start seeking out sustainable environmentally friendly fire-suppression approaches to reduce the environmental impacts during design and testing and also to help a project earn LEED credits.

Fire protection systems play an increasingly pivotal role in overall building design and construction and should never be comprised because they serve the purpose of life safety. Indeed, it is frequently argued that the life safety system is the most important system to be evaluated in a facility, particularly when it comes to high-rise structures. Furthermore, like any other building system, green concepts and specifications can be applied to their design, installation, and maintenance in a manner that reduces their harmful impacts on the environment. Moreover, there have been significant advances recently in fire-detection technology and fire suppression systems in addition to an ongoing development of international and national codes and standards all of which have made possible the “greening” of facility fire safety systems and which is taking on increasing importance for building owners and property developers.

For optimum efficiency, the various components of modern fire-protection systems should work in cohesion to detect, contain, control, and/or extinguish a fire in its early stages—and to survive during the fire. And the installation of environmentally friendly fire-protection technology can help earn credits under the U.S. Green Building Council’s LEED Green Building Rating System for new or retrofitted buildings. A facility’s type, size, and function will generally determine the complexity of the life safety system used.

In some of the smaller structures, the system may comprise of only smoke detectors and fire extinguishers. In other larger more complex buildings, a complete fire suppression system such as fire sprinklers is installed throughout the facility. An important aspect in the assessment of any life safety system includes verification that periodic maintenance, inspection, and testing of the main components of the system is being conducted. [Fig. 9.29](#) illustrates several types of life safety systems normally employed to address fire safety requirements. Each of these gives rise to their own set of issues which need to be taken into account in facility surveys.

The extent of a life safety system survey and the expertise required to perform such an evaluation varies greatly from facility to facility depending on its size and complexity. Additionally, fire detection and prevention technologies have become increasingly sophisticated, intelligent, and powerful in recent years. Frank Monikowski and Terry Victor of SimplexGrinnell highlight some of the advances and emerging technologies that can be found in today’s Life/Safety systems such as:

- *Control Mode Sprinklers*—standard manufactured sprinklers that limit fire spread and stunt high heat release rather than extinguish a fire; they also “prewet” adjacent combustibles.

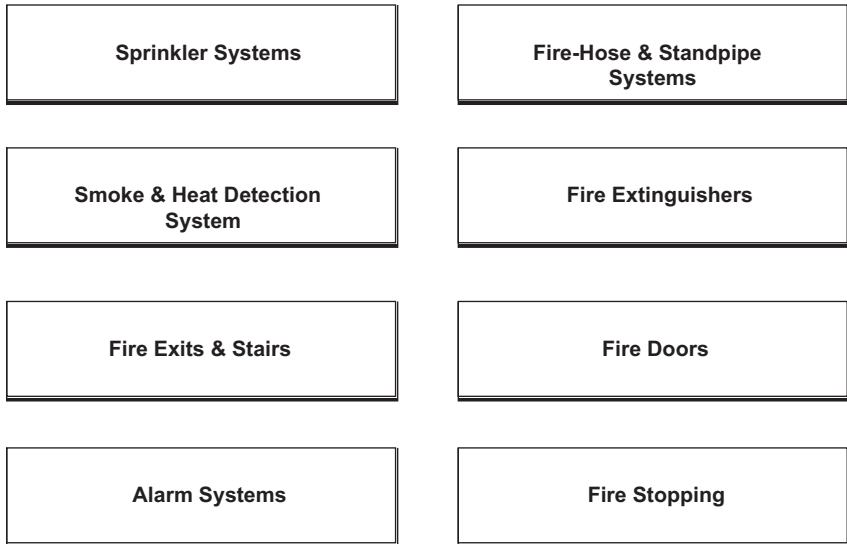

Figure 9.29 Typical fire suppression systems components.

- *Suppression Sprinklers*—operate quickly for high-challenge fires and are expected to extinguish a fire by releasing a high density of water directly to the base of the fire.
- *Fast-Response Sprinklers*—provide quicker response and are now required for all light-hazard installations.
- *Residential Sprinklers*—designed specifically to increase the survivability of an individual who is in the room where a fire originates.
- *Extended coverage sprinklers*—designed to reduce the number of sprinklers needed to protect a given area. These come in quick response, residential, and standard-response types and are also available for both light- and ordinary-hazard occupancies.
- *Special sprinklers, such as Early Suppression Fast Response (ESFR)*—designed for high-challenge rack storage and high-pile storage fires. In most cases, these sprinklers can eliminate the expense and resources needed to install in-rack sprinkler heads.
- *Low-pressure sprinklers*—provide needed water coverage in multistorey buildings where pressure may be reduced. These low-pressure sprinklers bring a number of benefits: reduced pipe size, reduction or elimination of a fire pump, and overall cost savings.
- *Low-profile, decorator, and concealed sprinklers*—designed to be more aesthetically pleasing.

- Sprinkler system valves that are smaller, lighter, and easier to install and maintain and, therefore, less costly.
- *A Fluid Delivery Time* computer program that simulates water flowing through a dry system in order to accurately predict critical “water-to-fire” delivery time for dry-pipe systems.
- *Cost-efficient CPVC piping* for light-hazard and residential sprinkler systems.
- *Advanced coatings on steel pipes*, designed to resist or reduce Microbiologically Influenced Corrosion (MIC) and enhance sprinkler system life.
- *Corrosion monitoring devices* to alert users of potential problems.
- *More efficient coordination in evaluating building sprinkler system need*—including site surveys, accurate measurements, and the use of CAD and hydraulics software to ensure that fire sprinkler system designs respond to the specific risks and the physical layout of the premises.

According to the NFPA, more than 43 million Americans have a disability, which is partly why the NFPA recently developed and issued a new Emergency Evacuation Planning Guide for People with Disabilities. This document provides general information to assist designers in identifying the needs of people with disabilities related to emergency evacuation planning. This guide covers five general categories of disabilities which are *mobility impairments, visual impairments, hearing impairments, speech impairments, and cognitive impairments*. The four elements of evacuation information needed by occupants are *notification, wayfinding, use of way, and assistance*.

9.8.1 LEED Contributions

Fire sprinklers have been an essential component in stopping fire growth and minimizing greenhouse and toxic gas production for over a century. Yet they are not given any credit in the USGBC’s LEED certification program. In fact, fire suppression systems are only indirectly referenced in LEED certification documents. For example, LEED for New Construction (LEED-NC) V3 Energy and Atmosphere (EA) Credit 4, Enhanced Refrigerant Management, and LEED for Existing Buildings: Operations & Maintenance (LEED EBOM) V3 EA Credit 5, Refrigerant Management, the intent being reducing ozone depletion, supporting compliance with the Montreal Protocol and minimizing direct contributions to global warming.

It appears that credits can be earned with the installation/operation of fire suppression systems that do not contain ozone-depleting substances such as CFCs, HCFCs, and halons. Likewise, LEED credits in the Innovation in Design category can also be obtained for fire suppression

systems. The LEED Reference Guide in the relevant category should be consulted, but generally, to earn those points, it is necessary to document and substantiate the innovation and design processes used. Dominick G. Kasmauskas who is with the National Fire Sprinkler Association says, “The fire sprinkler industry plans to work with the USGBC to develop a credit for fire sprinklers in future editions of LEED based on the environmental benefits of sprinkler systems.”

9.8.2 Sprinkler Systems

Since the dawn of history, people have used water as an extinguishing agent and today it is still the preferred choice for modern fire protection in the form of sprinklers and other methods. Sprinklers are the most common, widely specified and most effective fire suppression system in commercial facilities—particularly in occupied spaces. The various types of sprinkler systems are outlined next. However, in situations where the use of sprinklers is not feasible because of special considerations (e.g., water from sprinklers would damage sensitive equipment or inventory), alternative fire suppression systems might be decided upon, such as gaseous/chemical suppression. In the final analysis, the type of sprinkler system employed depends largely on a building’s function. When a system is operating as designed, fire sprinkler systems are highly reliable. However, like any other mechanical system, sprinkler systems need periodic maintenance and inspection in order to sustain proper operation. In the rare event a sprinkler system fails to control a fire, the root cause of failure is often the lack of proper maintenance (Fig. 9.30).

Automatic Sprinkler Systems

Optimized sprinkler system designs offer an effective means of addressing environmental impact and sustainability. Also, as they are the most widely specified, and most effective fire suppression system in commercial facilities, automatic sprinkler systems are now not only required in new high-rise office buildings, but in many American cities it is mandated by code that existing high rises be retrofitted with automatic sprinkler systems. There are several types of sprinkler systems that are commonly used, these include wet and dry pipes, preaction, deluge, and fire cycle systems. Of these, wet pipe and dry pipe are the most common. In a wet pipe system, the sprinklers are connected to a water supply, enabling immediate discharge of water at sprinkler heads triggered by the heat of the fire. In a dry pipe system, the sprinklers are under air pressure which, when the pressure is eased by the opening of the sprinkler heads, fills the system with water.

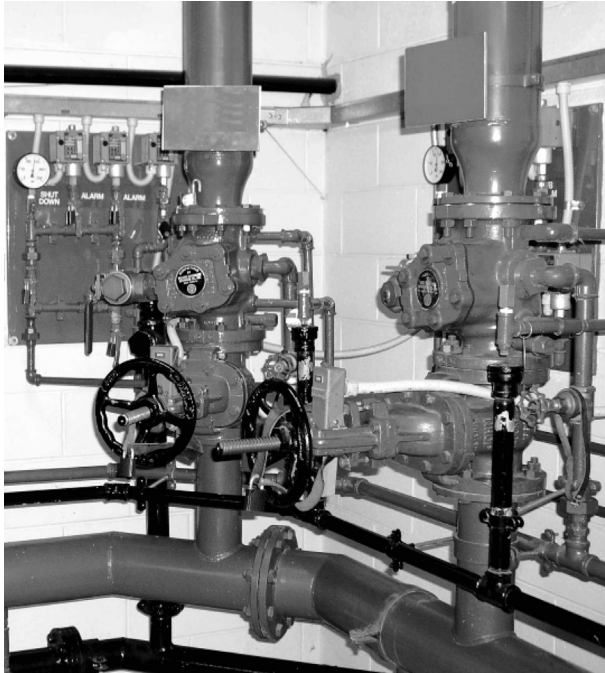

Figure 9.30 Typical fire sprinkler control valve assembly including pressure switches and valve monitors. *Courtesy: Wikipedia.*

Careful attention should be given to proper connections for flow and flow testing when designing automatic sprinkler systems. Likewise, flexible connections and arm overs may be employed to provide a means for facilitating the relocation of sprinklers with minimal need for additional materials if the system designer incorporates appropriate flow restrictions due to friction losses. In cases where employing water sprinklers are not feasible due to special considerations (e.g., water from sprinklers would damage sensitive equipment or inventory), alternative fire suppression systems such as gaseous/chemical suppression may be considered. But in the final analysis, the type of sprinkler system decided upon depends mainly on a building's function. Of note, the majority of today's fire sprinklers incorporate the latest advances in design and engineering technologies, thereby providing a very high level of life safety and property protection. The features and benefits now available are making fire sprinkler systems more efficient, reliable, and cost-effective. And as the benefits of sprinkler systems become better understood and more obvious, and the cost more affordable, their installation in residential structures is becoming more common. However, these sprinkler systems typically fall under a residential classification and not a commercial one.

The main difference between commercial and residential sprinkler systems is that a commercial system is designed to protect the structure and the occupants from a fire, whereas most residential systems are primarily designed to suppress a fire in a manner that allows for the safe escape of the building occupants. While these systems will often also protect the structure from major fire damage, this consideration nevertheless remains of secondary importance. In residential structures sprinklers are typically omitted from closets, bathrooms, balconies, and attics because a fire in these areas would not normally impact an occupant's escape route. When a system is operating as intended, fire sprinkler systems are highly reliable, but like any other mechanical system, sprinkler systems require periodic maintenance and inspection in order to sustain proper operation. In the rare event a sprinkler system does fail to control a fire, the root cause of failure has often been found to be the lack of proper maintenance.

Wet pipe systems: Wet pipe sprinkler systems are the most common and have the highest reliability. Wet Systems are typically used in buildings where there is no risk of freezing. The systems are simple with the only operating component being the automatic sprinkler. A water supply provides pressure to the piping, and all of the piping is filled with water adjacent to the sprinklers. The water is held back by the automatic sprinklers (Fig. 9.31) until activated. When one or more of the automatic sprinklers is exposed



Figure 9.31 Example of ceiling-mounted sprinkler head. *Source: Sujay Fire & Safety Equipment.*

to sufficient heat, the heat-sensitive element releases, allowing water to flow from that sprinkler. Each sprinkler operates individually. Sprinklers are manufactured to react to a specific range of temperatures, and only sprinklers subjected to a temperature at or above their specific temperature rating will operate. Fig. 9.32 shows a drawing of a typical wet pipe sprinkler system. The principal disadvantage of these systems is that they are not suited for subfreezing environments.

Dry Pipe Systems

This is the second most common sprinkler system type currently in use after the wet pipe system. A dry pipe sprinkler system is one in which pipes are filled with pressurized air or nitrogen, rather than water. This air holds a remote valve, known as a dry pipe valve, in a closed position. The dry pipe

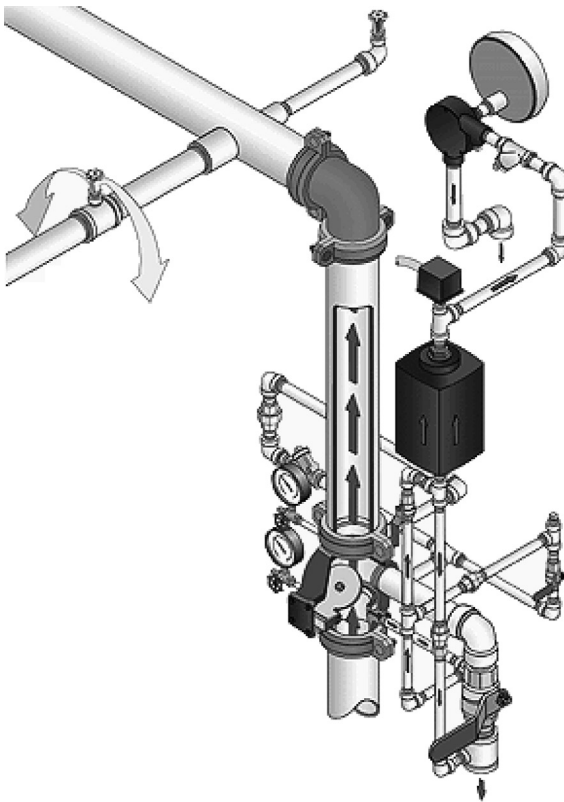

Figure 9.32 Diagram of typical wet pipe sprinkler system.

valve is located in a heated space and prevents water from entering the pipe until a fire causes one or more sprinklers to be activated. Once this happens, the air escapes and the dry pipe valve releases. To prevent the larger water supply pressure from forcing water into the piping system, the design of the dry pipe valve intentionally includes a larger valve clapper area exposed to the specified air pressure, as compared to the water pressure. Water then enters the pipe, flowing through open sprinklers onto the fire. However, regulations (NFPA 13 2007 ed. Sections 7-2 and A7-2) typically stipulate that these systems can only be used in spaces in which the ambient temperature may be cold enough to freeze the water in a wet pipe system, thus rendering it inoperable. For this reason we often find dry pipe systems used in unheated buildings and refrigerated coolers.

Activation (becomes operational) of the system takes place when one or more of the automatic sprinklers are exposed to sufficient heat, allowing the maintenance air to vent from that sprinkler. Each sprinkler operates individually. As the air pressure in the piping drops, the pressure differential across the dry pipe valve changes, allowing water to enter the piping system. Delays can be experienced in dry pipe systems, since the air pressure must drop before the water can enter the pipes and suppress the fire. Dry pipe systems are therefore not as effective as wet pipe systems in fire control during the initial stages of the fire although aid in faster activation, dry pipe valves may employ quick opening devices connected to them.

Deluge and Preaction Systems

These systems are less common and are used mainly in environments that require special sprinkler protection and are activated by fire detection systems. Deluge and preaction systems represent only a small percentage of market share of the total sprinkler systems currently in operation. The deluge fire sprinkler systems feature open-type sprinkler heads that are attached to a dry pipe which is connected to a main water supply. The utilization of an innovative detection system that recognizes smoke or heat, enables this fire suppression installation to activate a valve that releases water to all sprinklers.

Deluge systems are similar to preaction systems except that the sprinkler heads are open and the pipe is not pressurized with air. This means that in a Deluge system the heat sensing operating element is removed during installation, so that all sprinklers connected to the water piping system remain open by the operation of a smoke or heat detection system. These detection systems are normally installed in the same area as the sprinklers, so that

when the detection system is activated, water readily discharges through all of the sprinkler heads in the system.

These systems are typically used in high hazards areas because they provide a simultaneous application of water over the entire hazard and where rapid fire spread is a major concern such as power plants, aircraft hangars, and chemical storage facilities. Water is not present in the piping until the system operates. Because the sprinkler orifices are open, the piping is at ambient air pressure. To prevent the water supply pressure from forcing water into the piping, a *deluge valve* is used in the water supply connection, which is a mechanically latched nonresetting valve that stays open once tripped. Because the heat-sensing elements present in the automatic sprinklers have been removed (resulting in open sprinklers), the deluge valve must be opened as signaled by a specialized fire alarm system. The type of fire alarm activation device used is based largely on the hazard (e.g., smoke detectors or heat detectors). The activation/initiation device signals the fire alarm panel, which in turn signals the deluge valve to open. Activation can also be achieved manually, depending on the system goals. Manual activation is usually via an electric or pneumatic fire alarm pull station, which signals the fire alarm panel, which in turn signals the deluge valve to open, allowing water to enter the piping system. Water flow effectively takes place from all sprinklers simultaneously.

Preaction sprinkler systems, on the other hand, are specialized systems that combine a fire detection system with a sprinkler system. They are typically used to ensure reliable protection against false alarms in locations where accidental activation is undesired, such as in museums containing rare art works, or computer suites, etc. These sprinkler systems employ the basic concept of a dry pipe system in that water is not normally contained within the pipes. It differs from the dry pipe system however, in that water is held from entering the piping by an electrically operated valve, known as a preaction valve. Valve operation is controlled by a signal from the fire detection system, not by a fall in pressure after a sprinkler has opened. If there is a fault on the fire detection system, a preaction system is switched over to operate as a normal dry system. Preaction systems are hybrids of wet, dry, and deluge systems, depending on the exact system goal.

Preaction systems can be either single interlock or double interlock. The operation of single interlock systems are similar to dry systems except that these systems require that a “preceding” and supervised event (typically the activation of a heat or smoke detector) takes place prior to the “action” of water introduction into the system’s piping due to opening of the preaction

valve (i.e., a mechanically latched valve). The operation of double interlock systems is similar to a deluge system except that automatic sprinklers are used. Upon detection of the fire by the fire alarm system, it basically converts from a dry system into a wet system.

Water Mist Systems

Water mist systems consist of environmentally friendly systems that normally force water and pressurized gas together through stainless-steel tubes that are much narrower in diameter than pipes used in traditional sprinkler systems. The water mist system produces a fine mist with a large surface area that absorbs heat efficiently through vaporization. These systems are totally safe for humans because they utilize water as the extinguishing medium. With these systems, fires are suppressed using three main mechanisms:

1. As the water droplets contact the fire they convert to steam. This process absorbs energy from the surface of the burning material.
2. As the water turns into steam it expands greatly. This removes heat and lowers the temperature of the fire and the air surrounding it.
3. The water and the steam act to block the radiant heat and prevent the oxygen from reaching the fire (thus starving it of oxygen) so the fire smothers.

Water mist systems can be useful for suppressing fires in gas turbine enclosures, and machinery spaces and are FM (i.e., Factory Mutual) approved for such applications. Water mist systems are ideally suited for cultural heritage buildings where large amounts of water can potentially cause unacceptable damage to irreplaceable items and in retrofits where space is often limited. Water mist systems are also often used to protect passenger cruise ships, where the system's excellent performance and low total system weight have made them very popular.

Foam–Water Sprinkler Systems

This type of sprinkler system is a special application system, discharging a mixture of water and low-expansion foam concentrate, resulting in a foam spray from the sprinkler. These systems are generally more economical than a water-only system, when evaluated for the same risk, and provide for actual extinguishment of the fire and a lower water demand. The conversion assists in the reduction of property loss, loss of life, and in many cases the reduction of insurance rates. But while foam concentrates and expanded foams are generally considered to be safe with regard to exposure to humans, they can unless specifically indicated, adversely impact the environment if allowed to flow freely into watershed areas. The base properties of typical

foaming agents include nitrates, phosphorous, and organic carbon. It should be noted that the use of halons in fire suppression systems was phased out in the early 1990s to comply with the Montreal Protocol because they were determined to cause significant damage to the ozone layer. Moreover, halons have a long life in the atmosphere and a high GWP.

One of the characteristics of this system is that almost any sprinkler system—wet, dry, deluge, or preaction can be readily adapted to include the injection of AFFF foam concentrate in order to combat high risks situations. These systems are typically used with special hazards occupancies associated with high challenge fires, such as flammable liquids, and airport hangars. Added components to the sprinkler system riser include bladder tanks to hold the foam concentrate, concentrate control valves to isolate the sprinkler system from the concentrate until activation, and proportioners for mixing the appropriate amount of foam concentrate with the system supply water. The main standard that delineates the minimum requirements for the design, installation, and maintenance of foam–water sprinkler and spray system is NFPA 16 (National Fire Protection Association 16): Standard for the installation of Foam–Water Sprinkler and Foam–Water spray systems.

The checklist below is provided by the New York Property Insurance Underwriting Association to help identify general problems that may arise in typical sprinkler systems. This checklist is intended to identify what is required to be done and to assure that the sprinkler system is properly maintained:

- Are sprinkler heads free of paint, dust, and grease?
- Are the sprinkler heads obstructed by stored material? There should be no less than 18 inches of clearance at each head. Obstructions will diminish the operation of the head.
- Are the sprinkler pipes used to support lighting or other objects?
- Are there extra sprinkler heads and wrenches located at the control area for maintenance purposes?
- Is the O.S.&Y. valve chained in an open position to avoid disabling of the system?
- Are the sprinkler heads directed properly for their location?
- Is there a sprinkler contractor that supervises and inspects the system as required by N.F.P.A. and ISO? Is a service log maintained?
- Are the sprinkler alarms activated to protect your property in the event of accidental discharge or fire?
- Has the occupancy classification of the material in the building changed since its installation so that the sprinkler system is now ineffective?
- Is the heat supply in the premises adequate for the operation of a wet pipe system?

Fire Hose and Standpipe Systems

Michael O'Brian, president of Code Savvy Consultants says, "Standpipes are a critical tool that requires preplanning on first responding apparatus in order to be used effectively. The initial approval process for these systems is critical and the fire prevention bureau can assist responding crews by ensuring proper installation and maintenance of these systems. Standpipe systems vary in design, use, and location. These factors vary based on the adopted code; the use, size, and type of building they are installed in. Typically, model codes refer to NFPA 14, Standpipe and Hose Systems for the design, installation, and maintenance of these systems."

Standpipe Systems consist of piping, valves, outlets, and related equipment designed to provide water at specified pressures and installed exclusively for the fire department or trained occupant use for the fighting of fires. These systems are used in conjunction with sprinklers or hoses, and basically consist of a water pipe riser running vertically through the building, although sometimes a building is provided with only piping for the standpipe system.

Standpipe systems can be wet or dry. Dry systems are normally empty and are not connected to a water source. A Siamese fitting is located at the bottom end of the pipe, allowing the fire department to pump water into the system. In a wet-type system, the pipe is filled with water and attached to a tank or pump. This type also contains Siamese fittings for the fire department's use.

O'Brian says, "Many buildings are required to have an Automatic Class I standpipe system with a design pressure of 100 psi. Based on friction loss, municipal water supply, and pressure loss for the height of the standpipe a fire pump may need to be designed into the system. Due to the pressure requirements standpipes are limited to a maximum height of 275 ft. Those buildings over 275 ft in height will require the standpipe systems to be split in different pressure zones."

Model fire and building codes stipulate among other things, the requirements for the installation of standpipe systems. The specific type of system is based on the occupancy classification and building height. The three main classifications of Standpipe systems are:

- Class I standpipe signifies that it equipped with a 2.5-inch (64 mm) fire hose connection for fire department use and those trained in handling heavy fire streams. These connections must match the hose thread utilized by the fire department and are typically found in stairwells of buildings. In high-rise buildings which do not have sprinklers and beyond the reach of fire department ladders, Class I systems provide water supply for the primary means of firefighting, i.e., manually.

- Class II standpipe system is one directly connected to a water supply and serves a 1.5-inch (38 mm) fire hose connection that provides a means for the control or extinguishment of incipient-stage fires. They are typically found in cabinets, are intended for trained occupant use, and are spaced according to the hose length. The hose length and connection spacing is intended for all spaces of the building.
- Class III standpipe system is a combined standpipe system (i.e., combining both Class I and II connections) directly connected to a water supply and is for the use of in-house personnel capable of furnishing effective water discharge during the more advanced stages of fire in the interior of workplaces. Many times these connections will include a 2.5-inch reducer to a 1.5-inch connection.

When a standpipe system *control valve* is located within a stairwell, the maximum length of hose should not exceed 100 ft. If the control valve is located in areas other than the stairwell, the length of hose should not exceed 75 ft. Code requires that fire hoses on Class II and Class III standpipe systems be equipped with a shutoff-type nozzle.

9.8.3 Handheld Fire Extinguishers

There are several different classifications of fire extinguishers, each of which extinguishes specific types of fire (Fig. 9.33). Newer fire extinguishers use a picture/labeling system to designate which types of fires they are to be used on, whereas older fire extinguishers are labeled with colored geometrical shapes with letter designations (Fig. 9.34).

Classification of HandHeld Fire Extinguisher

The U.S. Department of Labor says, “Portable fire extinguishers are classified to indicate their ability to handle specific classes and sizes of fires. Labels on extinguishers indicate the class and relative size of fire that they can be expected to handle.” These classifications are as follows:

Class A Fire Extinguishers are designed to put out fires caused by organic solids and ordinary combustibles like wood, textiles, paper, some plastic, and rubber. The numerical rating for this class of fire extinguisher refers to the amount of water the fire extinguisher holds and the amount of fire it will extinguish. To extinguish a Class A fire, extinguishers utilize either the heat-absorbing effects of water or the coating effects of certain dry chemicals. Class A fire extinguishers should be clearly marked with a triangle containing the letter “A.” If in color, the triangle should be green.

Class B Fire Extinguishers are used to put out fires involving Flammable and Combustible Liquids and Gases. They work by starving the fire of oxygen and interrupting the fire chain by inhibiting the release of combustible vapors. Class B fires include gasoline, oil, and



MP, HT & DC SERIES



WC 2½ & WC 6L



PW 2½ & WM 2½



CD SERIES

Figure 9.33 Various types of fires extinguishers in common use: (1) MP series multipurpose dry chemical; (2) DC series regular dry chemical; (3) WC series wet chemical; (4) WM series water mist; (5) CD series carbon dioxide; (6) HT series Halotron I. *Source: Larsen's Manufacturing Co.*

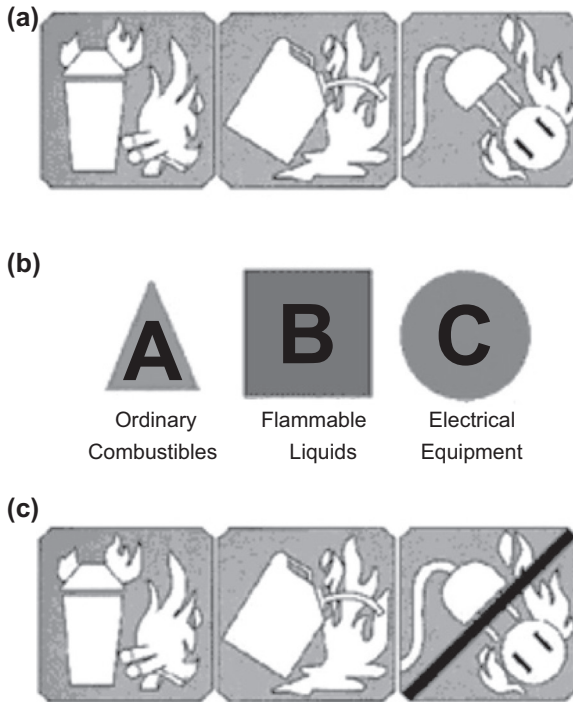

Figure 9.34 New and old style labeling systems indicating suitability for use on Class A, B, and C fire extinguishers.

paraffin. The numerical rating for this class of fire extinguisher states the approximate number of square feet of a flammable liquid fire that a non-expert person can expect to extinguish. This includes all hydrocarbon- and alcohol-based liquids and gases that will support combustion. Class B fire extinguishers should be clearly marked with square containing the letter “B.” If in color, the square should be red.

Class C Fire Extinguishers are most effective for use on fires that involve live electrical equipment where a nonconducting material is required. This class of fire extinguishers does not have a numerical rating, but the presence of the letter “C” indicates that the extinguishing agent is nonconductive. Class C fire extinguishers should be clearly marked by a circle containing the letter “C.” If in color, the circle should be blue.

Class D Fire Extinguishers are special types designed and approved for specific combustible materials (metals) such as magnesium, titanium, zirconium, potassium, sodium, etc., which require an extinguishing medium that does not react with the burning metal. Class D fire

extinguishers should be clearly marked by a five-point painted star containing the letter “D.” If in color, the star should be colored yellow. These extinguishers generally have no rating nor are they given a multipurpose rating for use on other types of fires.

Class K Fire Extinguishers are effective for fighting fires involving cooking fats, grease, oils, etc., in commercial cooking environments. These fire extinguishers work on the principle of saponification, which takes place when alkaline mixtures such as potassium acetate, potassium citrate, or potassium carbonate are applied to burning cooking oil or fat. The alkaline mixture combined with the fatty acid creates soapy foam on the surface which holds in the vapors and steam and extinguishes the fire. Class K fire extinguishers should be clearly marked with the letter “K.”

Labeling

If a multipurpose extinguisher is being used and in order for users to be able to quickly identify the classification of a fire extinguisher in the event of an emergency, each unit should be clearly labeled. The approved marking system combines pictographs of both recommended and unacceptable extinguisher types on a single identification label. Many extinguishers available today can be used on different types of fires and will be labeled with more than one designator, e.g., A-B, B-C, or A-B-C. It should also be noted that British Standards and classifications differ slightly from American Standards and classifications.

Types of Fire Extinguishers

There are several types of fire extinguishers, the most important being:

Dry Chemical extinguishers come in a variety of types and are usually rated for multiple purpose use (class A, B, and C fires). They are filled with a foam or powder extinguishing agent and use a compressed, non-flammable gas as a propellant. One advantage a dry chemical extinguisher has over a CO₂ extinguisher is that it leaves a nonflammable substance on the extinguished material, reducing the likelihood of reignition.

Water extinguishers or APW extinguishers (air-pressurized water) are filled with water and pressurized with oxygen. APW extinguishers should only be used on Class A (ordinary combustibles) fires and never on grease fires, electrical fires, or class D fires—the flames will only spread and likely make the fire bigger.

Carbon Dioxide (CO₂) extinguishers contain carbon dioxide, a nonflammable gas, and are highly pressurized. They are most effective on Class B

and C (liquids and electrical) fires. Since the gas disperses quickly, these extinguishers are only effective from 3 to 8 ft. The carbon dioxide is stored as a compressed liquid in the extinguisher; as it expands, it cools the surrounding air. The cooling will often cause ice to form around the “horn” where the gas is expelled from the extinguisher. However, they do not work very well on class A fires because they may not be able to displace enough oxygen to put the fire out, causing it to reignite. The advantage of CO₂ extinguishers has over dry chemical extinguishers is that they do not leave a harmful residue and may therefore be a good choice for an electrical fire on a computer or other favorite electronic device such as a stereo or TV.

Halon extinguishers contain a gas that interrupts the chemical reaction that takes place when fuels burn. Halon is an odorless, colorless gas that can cause asphyxiation and halon extinguishers have a limited range, usually 4–6 ft. An advantage of halon is that it is a clean agent because it leaves no corrosive or abrasive residue after release, minimizing cleanup which makes it more suitable for valuable electrical equipment, computer rooms, telecommunication areas, theaters, etc. However, pressurized fire suppression system cylinders can be hazardous and if not handled properly are capable of violent discharge. Moreover, the cylinder can act as projectile, potentially causing injury or death. Halon has been banned from new production, except for military use, since January 1, 1994 because its properties contribute to ozone depletion and long atmospheric lifetime, usually 400 years. However, Halon reuse is still permitted in the United States.

NFPA Code 10 addresses all the issues pertaining to portable fire extinguishers and contains the clear, widely accepted rules for distribution and placement, maintenance, operation, inspection, testing, and recharging. Recognized as a first line of defense against fires, portable extinguishers when maintained and operated properly on a small containable fire, can prevent it from spreading beyond its point of origin. NFPA Code 10 requires owners of extinguishers to have monthly inspections performed and to maintain records of the inspections.

9.8.4 Smoke and Heat Detection Systems

Smoke and heat detection systems play a pivotal role in green buildings. Kate Houghton, Director of marketing for Kidde Fire Systems says, “By detecting a fire quickly and accurately (i.e., by not sacrificing speed or causing false alarms) and providing early warning notification, a fire-detection system can

limit the emission of toxic products created by combustion, as well as global-warming gases produced by the fire itself. These environmental effects often are overlooked, but undoubtedly occur in all fire scenarios. Therefore, reducing the likelihood of a fire is an important part of designing a green building.”

A *smoke detector* or *smoke alarm* is a device that detects smoke and issues an alarm to alert nearby people of the threat of a potential fire. Smoke alarms that are properly installed and maintained play a critical role in reducing fire deaths and injuries. Household smoke detectors will typically be mounted in disk-shaped plastic enclosures about 150 mm in diameter and 25 mm thick, but the shape can vary by manufacturer (Fig. 9.35). Because smoke rises, most detectors are mounted on the ceiling or on a wall near the ceiling. It is imperative that smoke detectors are regularly maintained and checked that they operate properly. This will ensure early warning to allow emergency responses to occur well before a fire causes serious damage. It is not uncommon for modern types of systems to detect smoldering cables or overheating circuit boards. Smoke detectors are typically powered by one or more batteries but some can be connected directly to a building’s wiring. Often the smoke detectors that are directly connected to the main wiring system also have a battery as a power supply backup in case the facility’s wiring goes out. Batteries should be checked and replaced periodically to ensure appropriate protection. Early detection can save lives and help limit damage and downtime. Laws governing the installation of smoke detectors may differ from one jurisdiction to another.



Figure 9.35 Drawing of ceiling-mounted smoke detector. *Courtesy: Scott Easton.*

Most smoke detectors work either by optical detection or by ionization, and in some cases both detection methods are used to increase sensitivity to smoke. A complete fire-protection system will typically include spot smoke detectors that can signal a fire control panel to deploy a fire suppression system. Smoke detectors can either operate alone or be interconnected to cause all detectors in an area to sound an alarm if one is triggered, or be integrated into a fire alarm or security system. Smoke detectors with flashing lights are also available for the deaf or hearing impaired. Smoke detector cannot detect carbon monoxide to prevent carbon monoxide poisoning unless they come with integrated carbon monoxide detectors.

Aspirating smoke detectors (ASD) can detect combustion at the early stages and are 1000 times more sensitive than conventional smoke detectors, giving early warning to building occupants and owners. An ASD consists of a central detection unit which draws air through a network of pipes to detect smoke, and in most cases requires a fan unit to draw in a representative sample of air from the protected area through its network of pipes. Although ASDs are extremely sensitive and are capable of detecting smoke before it is even visible to the human eye, their use is not recommended in environments that are unstable due to the wide range of particle sizes that are detected.

Optical Smoke Detectors are light sensors. When used as a smoke detector it includes a light source (infrared LED), a lens to collimate the light into a beam like a laser, and a photodiode or other photoelectric sensor at right angles to the beam as a light detector. Under normal conditions (i.e., in the absence of smoke) the sensor device detects no light signal and therefore produces no output. The source and the sensor device are arranged so that there is no direct “line of sight” between them. When smoke enters the optical chamber into the path of the light beam, some light is scattered by the smoke particles, and some of the scattered light is detected by the sensor, and the alarm is set off by the increased input of light into the sensor.

Projected beam detectors are not like traditional detection systems. Reflected Beam Smoke Detectors were designed for spacious rooms, open areas, and high ceilings; their innovative features make them popular choices for spaces like warehouses, atriums, arenas, and churches. They usually require only one device to install and align, thus saving time and money on open-area and high-ceiling applications. A unit on the wall typically transmits a beam, which is either received by a receiver, or reflected back via a mirror. When the beam is less visible to the “eye” of the sensor, it sends an alarm signal to the Fire alarm control panel

(FACP). Optical smoke detectors are generally quick in detecting slow burning, smoky fires.

Ionization detectors are sometimes known as an ionization chamber smoke detector, is capable of quickly sensing flaming fires that produce little smoke. It employs a radioactive material (a very small amount of americium-241) to ionize the air in a sensing chamber; the presence of smoke affects the flow of the ions between a pair of electrodes, which triggers the alarm. While over 80% of the smoke detectors in American homes are of this type and although ionization detectors are less expensive than optical detectors, they are frequently rejected for projects seeking LEED certification for environmental reasons. The majority of residential models are self-contained units that operate on a 9-V battery, but construction codes in some parts of the country now require installations in new homes to be connected to the house wiring, with a battery backup in case of a power failure.

Heat Detectors can detect heat and can be either electrical or mechanical in operation. They are set to alarm when ambient temperatures reach a fixed point, typically indicating a fire. Fixed-temperature heat detectors are a very cost-effective solution for many property protection applications. There are also combination heat detectors which are employed to provide both fixed and rate-of-rise detection, thus enabling the heat detector to communicate an alarm to the central control panel prior to reaching its fixed set point for high rates of rise, thus providing a timely response to both rapid and slow temperature increases. Most heat detectors are designed to trigger alarms and notification systems before smoke even becomes a factor. The most common types of heat detectors are the thermocouple and the electropneumatic, both of which respond to changes in ambient temperature. Typically, if the ambient temperature rises above a predetermined threshold, an alarm signal is triggered.

Good detection has many benefits (beyond triggering the alarm system) the main one being that in many cases, there is a chance to extinguish a small, early blaze with a fire extinguisher. Also, intelligent smoke detectors can differentiate between different alarm thresholds. These systems typically have remote detectors located throughout the facility which are connected to a central alarm system.

9.8.5 Fire Doors

Fire doors form a vital component of a building's passive fire protection system, and doors in a means of egress provide life safety by allowing people to exit quickly when necessary. Still, the requirements remain unclear for

Table 9.4 Fire-rated door and glass lites classification

Class	Fire rating	Location and use	Glass lite size		Width
			allowed		
A	3 h	Fire walls separating buildings or various fire areas within a building; 3–4 h walls	None	None	None
B	½ h (HM) 1 h (other)	Vertical shafts and enclosures such as stairwells, elevators, and garbage chutes; 2 h walls	100 in	33 in	10–12 in
B	1 h	Vertical shafts in low-rise buildings and discharge corridors; 1–1½ h walls	100 in	33 in	10–12 in
C	¾ h	Exit access corridors and exitway enclosures; 1 h walls	1296 in	54 in	54 in
N/A	20 min (⅓ h)	Exit access corridors and room partitions; 1 h walls	No limit	No limit	No limit

many architects and specifiers. Fire doors are essentially doors made of fire-resistant material that can be closed to prevent the spread of fire and are designed to provide extra fire-spread protection for certain areas of a building (Table 9.4). The fire rating classification of the wall into which a door is installed dictates the required fire rating of the door. The location of the wall in the building and prevailing building code establishes the wall's fire rating. Fire doors are normally installed staircases from corridors or rooms, cross-corridor partition, to laboratories, plant rooms, workshops, store-rooms, machine rooms, service ducts, and kitchens as well as to defined fire compartments. They are also employed in circulation areas which extend the escape route from the stair to a final exit or to a place of safety, and entrances and lobbies; at routes leading onto external fire escapes, and corridors that are protected from adjoining accommodation by fire-resisting construction.

Fire door requirements are sometimes included within the applicable building or fire code, but NFPA 80 and 105 are typically referenced for many of the detailed requirements. According to the NFPA, doors are rated with respect to the number of hours they can be expected to withstand fire before burning through. There are 20-, 30-, 45-, 60-, 90-min rated fire

doors as well as 2HR and 4HR rated fire doors that are certified by an approved laboratory such as Underwriters Laboratories (UL). Because Fire Doors are rated physical fire barriers that protect wall openings from the spread of fire, they are required to provide automatic closing in the event of fire detection. Fire doors should usually be kept closed at all times, although some fire doors are designed to stay open under normal circumstances, and are designed to close automatically or manually in the event of a fire. Fire Door release devices are electromechanical devices that enable automatic closing fire doors to respond to alarm signals from detection devices such as smoke detectors, heat detectors, and central alarm systems. This permits closing the door before high temperatures melt the fusible link. Fusible links should always be used as backup to the releasing device.

Fire-Rated Door Assemblies comply with NFPA 80 and are listed and labeled by UL, for the fire ratings indicated, based on testing according to NFPA 252. Assemblies must be factory-welded or come complete with factory-installed mechanical joints and must not require job fabrication on site.

Exit Routes

What is an exit route? As defined by OSHA, an exit route is a continuous and unobstructed path of exit travel from any point within a workplace to a place of safety. OSHA says that an exit route consists of three parts:

- Exit access—portion of an exit route that leads to an exit.
- Exit—portion of an exit route that is generally separated from other areas to provide a protected way of travel to the exit discharge.
- Exit discharge—part of the exit route that leads directly outside or to a street, walkway, refuge area, public way, or open space with access to the outside.

All buildings require fire exits which enable users to exit safely in the event of an emergency. Well-designed emergency exit signs are necessary for emergency exits to be effective. In the United States, fire escape signs often display the word “EXIT” in large, well-lit, green, or red letters. An exit route must be permanent and must be separated by fire-resistant materials. Construction materials used to separate an exit from other parts of the workplace must have a 1-h fire resistance rating if the exit connects three or fewer stories and a 2-h fire resistance rating if the exit connects four or more stories.

Unless otherwise stipulated by code, at least two exit routes must be provided in a workplace to permit prompt evacuation of employees and other building occupants during an emergency. The exit routes must be located

as far away as practical from each other so that if one exit route is blocked by fire or smoke, employees can evacuate using the second exit route. More than two exit routes must be available in a workplace if the number of employees, the size of the building, its occupancy, or the arrangement of the workplace is such that all employees would not be able to evacuate safely during an emergency. Likewise, a single exit route is permitted where the number of employees, the size of the building, its occupancy, or the arrangement of the workplace is such that all employees would be able to evacuate safely during an emergency.

Exit routes must be free and unobstructed, and must be arranged so that employees are not required to travel toward a high hazard area, unless the path of travel is appropriately shielded from high hazard areas by suitable partitions or other physical barriers. No materials or equipment may be placed, either permanently or temporarily, along the exit route. The exit access must not go through a room that can be locked, such as a bathroom, to reach an exit or exit discharge, nor may it lead into a dead-end corridor. Where the exit route is not substantially level, it is necessary to have stairs or ramps.

OSHA requirements stipulate that each exit discharge must lead directly to the exterior or to a street, walkway, refuge area, public way, or open space with access to the outside. The street, walkway, refuge area, public way, or open space to which an exit discharge leads must be large enough to accommodate the building occupants likely to use the exit route. Exit stairs that continue beyond the level on which the exit discharge is located must be interrupted at that level by doors, partitions, or other effective means that clearly indicate the direction of travel leading to the exit discharge.

It is important to note that exit doors must not be locked from the inside, and each doorway or passage along an exit access that could be mistaken for an exit (such as a closet) must be marked "Not an Exit" or similar designation, or be identified by a sign indicating its actual use. Furthermore, exit route doors must be free of decorations or signs that obscure the visibility of the exit route door, and employees must be able to readily open an exit route door from the inside at all times without keys, tools, or special knowledge. A device such as a panic bar that locks only from the outside is permitted on exit discharge doors. Exit route doors may be locked from the inside only in mental, penal, or correctional facilities and then only if supervisory personnel are continuously on duty and the employer has a plan to remove occupants from the facility during an emergency.

Where a fall hazard exists in the use of an outdoor exit route, it must have guardrails to protect unenclosed sides. If snow or ice is likely to accumulate

along the route it must be covered, unless it can be demonstrated that any snow or ice accumulation will be removed before it presents a slipping hazard. Also, the outdoor exit route must be reasonably straight and have smooth, solid, substantially level walkways, and must not have a dead-end that is longer than 20 ft (6.2 m).

To protect people and property during building fires requires the employment of three essential design elements:

- Alarms to provide early warnings,
- Automatic sprinklers or other suppression systems, and
- Fireproof compartments to contain flames and smoke.

These elements work together to give occupants time to escape and fire-fighters time to arrive. Eliminating any one of the three fire protection elements—detection, suppression, or compartmentation would compromise the integrity of the building.

Compartmentation

Building regulations in most jurisdictions stipulate that large buildings need to be divided into compartments and that these fire compartmentations must be maintained should a fire occur. In order to do this there are a range of fire-stopping products and methods available offering between 30 and 240 min fire compartmentation protection for construction movement joints and service penetrations. A fire compartment can therefore be defined as a space within a building extending over one or several floors that is enclosed by separating members such that the fire spread beyond the compartment is prevented during the relevant fire exposure. Fire compartments are sometimes referred to as *Fire Zones*. Compartmentation is critical to preventing a fire to spread into large spaces or into the whole building. It involves the specification of fire-rated walls and floors sealed with fire-stop systems, fire doors, and fire dampers, and the like. But to be effective the walls, floor, and ceiling need to contain flames and smoke within the compartment. These components must also provide sufficient insulation to prevent excessive heat radiating outside the compartment.

The division of the building into discrete fire zones offers perhaps the most effective means of limiting fire damage. Compartmentation techniques are designed to contain the fire to within the zone of origin, by limiting vertical and horizontal fire spread. Compartmentation also provides at least some protection for the rest of the building and its occupants even if first aid fire fighting measures are used and fail. It also provides protection for inventory and business operations and delays the spread of fire prior to the arrival

of the fire brigade. But determining the required fire resistance for a compartment depends largely upon its intended purpose and on the expected fire. Either the separating members enclosing the compartment shall resist the maximum expected fire or contain the fire until occupants are evacuated. The load-bearing elements in the compartment must always resist the complete fire process or be classified to a certain resistance measured in terms of periods of time, which is equal or longer than the requirement of the separating members. The most important elements to be upgraded are the doors, floors, and walls, penetrations through floors and walls, and cavity barriers in the roof spaces. Halls and landings should typically be separated from staircases to prevent a fire from traveling vertically up or down the stairwell to the other floors. However, creation of new lobbies can have an unacceptable negative impact on the character of a fine historic interior. To be effective therefore, compartmentation needs to be correctly planned and implemented.

The main function of fire stopping is to stop the spread of fire between floors of a building. Flame retardant material is installed around floor openings designed to contain conduit and piping. A firestop is a product that when properly installed, impedes the passage of fire, smoke, and toxic gases from one side of a fire-rated wall or floor assembly to another. Typical fire-stop products include sealants, sprays, mechanical devices (firestop collar), foam blocks, or pillows. These products are installed primarily in two applications: (1) around penetrations that are made in fire-resistive construction for the passage of pipes, cables, or HVAC systems, and (2) where two assemblies meet, forming an expansion joint such as the top of a wall, curtain wall (edge of slab), or floor-to-floor joints. Typical opening types include the following:

- Electrical through-penetrations
- Mechanical through-penetrations
- Structural through-penetrations
- Nonpenetrated openings (e.g., openings for future use)
- Reentries of existing firestops
- Control or sway joints within fire-resistance rated wall or floor assemblies
- Junctions between fire resistance-rated wall or floor assemblies
- “Head-of-wall” joints where nonload bearing wall assemblies meet floor assemblies.

Compliance with all applicable laws and regulations relating to a building is the owner’s responsibility including the adopted and enforced fire code within a specific jurisdiction. Fire codes govern the construction,

protection, and occupancy details that affect the fire safety of buildings throughout their life span. Numerous different fire codes have been adopted throughout the United States—the vast majority of which are similar and based on one of the model codes available today or in the past. One requirement in all of these model codes is that fire safety features incorporated into a building at the time of its construction must be maintained throughout a building's life. Therefore, this would require any fire resistance-rated construction to be maintained (Fig. 9.36).

The Safest Test Method...

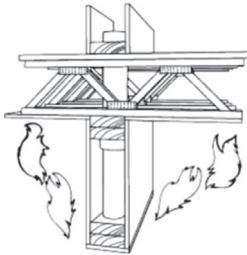

(Fig. 1)

Chase Wall testing (Fig. 1) does not evaluate performance where the fire enters or starts within the cavity.

Systems tested as **Through-Penetrations** provide a worst-case evaluation, indicating performance of the firestop regardless of the wall.

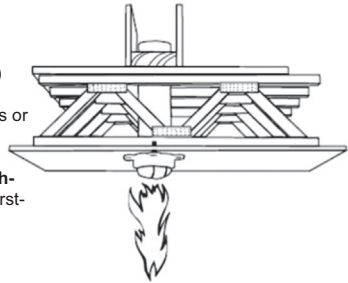

(Fig. 2)

Smoke Seals or Firestops?

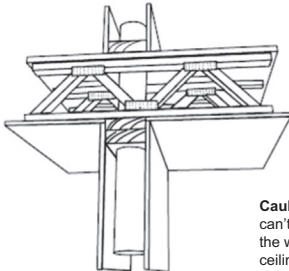

(Fig. 3)

Caulk Only systems (Fig. 3) provide a seal but can't shut down a burning pipe. A fire in the wall cavity can quickly spread to the ceiling and wall cavities above (Fig. 4).

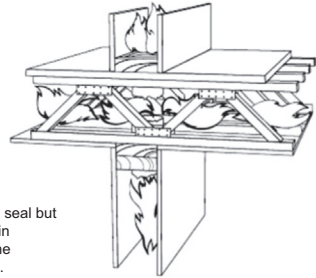

(Fig. 4)

Shutting Off The Part Of A Fire

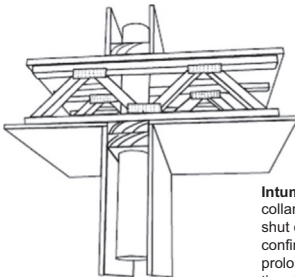

(Fig. 5)

Intumescent systems like the firestop collar installed below the top plate (Fig. 5) shut down burning pipes helping to confine the fire to its point of origin (Fig. 6), prolonging structural integrity and buying time for occupants to safely exit the building.

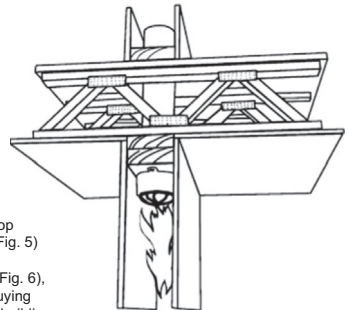

(Fig. 6)

Figure 9.36 Drawing showing various fire stopping systems used in construction.

Alarm Systems and Notification Systems

Fire alarm systems are essential to any facility, particularly in large buildings where there may be visitors or personnel who are unfamiliar with their surroundings. Bruce Johnson, Regional Manager for Fire Service Activities with the International Code Council says, “Fire alarm systems and smoke alarms are life safety systems that save countless lives each year, both civilians and firefighters. The *International Residential Code* requires interconnected, hardwired smoke alarms in all new construction (Section R313) and the *International Building Code* and *International Fire Code* (Section 907.2) call for manual or automatic fire alarm systems in most commercial buildings with high life occupancy or other hazards. In addition to new construction, the *International Fire Code* also has provisions for fire alarm systems and smoke alarms in existing structures (Section 907.3)”. Fire alarms alert building occupants of a fire that alert emergency public responders (police and fire) through a central station link to initiate appropriate responses.

FACPs, or fire alarm control units, comprise of electric panels that function as the controlling components of a fire alarm system (Fig. 9.37). The FACP panel receives information from environmental sensors designed to detect any changes associated with fire. It also monitors their operational integrity and provides for automatic control of equipment, and transmission of information necessary to prepare the facility for fire based on a predetermined sequence. An FACP panel may also supply electrical energy to operate any associated sensor, control, transmitter, or relay. There are currently four basic types of FACP panels on the market: coded panels, conventional panels, addressable panels, and multiplex systems.

Mass Notification systems (MNSs) are invaluable in the protection of a wide range of facilities, and MNSs use both audible and visible means to distribute potential life-saving messages. An MNS is much more than an alarm system. By using the technologies based on fire alarm codes and standards, fire system manufacturers are able to produce a robust life safety and security system.

The impact of increasingly sophisticated technology has had a significant impact on today’s alarm systems. For example, they now have the ability to provide more information to the fire department and first responders. In many cases, they can do more than just tell them that there has been an alarm in the building; they can be directed by the kind of alarm and where the alarm is. Moreover, many modern systems now include speakers that provide alerts in place of (or in addition to) traditional bell-type alarms. These speakers also can be used in emergencies other than fires to



Figure 9.37 A Siemes MXL fire alarm control panel (top) and graphic annunciator (bottom) for Potomac Hall, at James Madison University. *Photograph by Ben Schumin, (source: Wikipedia).*

instruct and inform occupants of the situation. These voice-actuated systems can include prerecorded or live messages that play in the event of fire or another emergency. Typical prerecorded messages tell occupants that an alarm has been sounded and that they should remain in their designated area for further instruction. Building management can then manually use the system to deliver additional information and prepare occupants for an evacuation, if necessary. Alert systems can also close fire doors, recall elevators, and interface and monitor the installed suppression systems, such as sprinklers. It should be noted that when fire alarms systems are properly installed and maintained, they perform very well. But when they are not, the public and fire service may be subject to unnecessary “false alarms” that puts everyone at risk.

Alarm systems can also connect with a building’s ventilation, smoke management, and stairwell pressurization systems—all of which are critical

to life safety. Again, these features are dependent on the building in which the particular system is installed. In addition, the integration of MNS and fire alarm control systems is a growing and positive trend that will hopefully continue and be applied in larger varieties of facilities and multibuilding properties, including schools, high-rise buildings, mass transit hubs, and even public gathering places such as places of worship, theaters, and restaurants.

An annunciator is basically a unit containing two or more indicator lamps, alpha-numeric displays, or other equivalent means in which each indication provides status information about a circuit, condition, or location. An annunciator panel is sometimes employed to monitor the status of the different areas in a designated fire zone, theft protection, and control of a facility's alarm devices. There may be several fire zones in a building. Each fire zone is clearly marked on the panel. The annunciator panel identifies the different zones and their specific security status. Should a fire occur, an indicator light flashes on the panel and identifies the fire's location. For example, the light on the panel might indicate that a fire has occurred in Fire Zone 4. This information allows the Fire Department to quickly locate the fire.

9.8.6 Codes and Standards

One of the most important objectives of any design must be Code compliance. There are a number of relevant national codes that relate to green building fire protection systems that are published by the NFPA. It should be noted that fire codes can vary substantially from one jurisdiction to another, and while these codes are not mandatory in all jurisdictions, they should nevertheless be adhered to whenever possible because they provide maximum safety for property and personnel and can help guide system design and installation:

NFPA 72, *National Fire Alarm Code*: Governs the design, installation, operation, and maintenance of fire detection and alarm systems. It includes requirements for detector spacing, occupant notification, and control panel functionality.

NFPA 750, *Standard on Water Mist Fire Protection Systems*: Governs water mist system classification and incorporates requirements for water mist system design, installation, operation, and maintenance.

NFPA 2001, *Standard on Clean Agent Fire Extinguishing Systems*: Governs the design, installation, operation, and maintenance of clean-agent systems. It additionally includes requirements for assessing design concentrations, safe personnel-exposure levels, and system-discharge times.

The standard also stipulates that an agent be included on the U.S. Environmental Protection Agency's (EPA's) Significant New Alternatives Policy list.

Finally, green buildings today have numerous fire protection system options that can be employed. Careful consideration of a building and its anticipated hazards will help determine which areas require protection. Due to the recent advances in technology, fire detection and suppression systems can now adequately support and sustain a modern green building philosophy. The methodical selection of a clean-agent or water mist system can also help contribute to LEED certification credits for building owners and developers.

However, "The new methods and materials that are used to support green building concepts can result in specific fire hazards, just like in traditional building design," says Craig Hofmeister, Vice President of engineering technology for RJA Group. "That means green concepts should be reviewed as part of a fire protection and life safety analysis." The bottom line is that performance-based codes can be used as an excellent tool to resolve conflicts between progressive green design elements and prescriptive codes. Armin Wolski, Head of the San Francisco fire engineering group and Associate Principal at Arup says, "A particular design element might not comply with the letter of the code," Wolski goes on to say, "but for a given use or intent, often the element can be analyzed from a performance perspective and shown to meet the intent of the code."



Green Design and Building Economics



10.1 GENERAL

A recent Green Building Economic Impact Study, released by the U.S. Green Building Council (USGBC) which was prepared by Booz Allen, finds the green building industry contributes more than \$134.3 billion in labor income to working Americans. The study also found that green construction's growth rate is rapidly outpacing that of conventional construction and will continue to rise. Indeed, over the past decade, popular attention to "green" building has increased dramatically to the extent that the built environment and sustainability have become closely intertwined. Moreover, building "green" affords us an opportunity to use our resources more efficiently while simultaneously creating buildings that enhance human health, build a better environment, and provide cost savings. Peter Morris, principal of the global construction consultancy Davis Langdon believes that the dramatic reduction in construction activity in recent years is encouraging increased competition among bidders and lower escalation pressure on projects to the extent that in many projects, cost trends have become negative, leading to moderate construction price deflation. But one of the biggest causes of concern according to Morris is the issue of contractor financing and working capital. Many contractors are finding it increasingly difficult to maintaining adequate cash flow for their operations, and few have the resources to manage significant expansion of working capital. This has caused considerable concern in the construction industry and has obliged many bidders to be more cautious and judicious in project selection, with a focus on projects that have sound cash flows.

More and more professionals and property developers are rightly becoming aware of the significant benefits that green buildings have to offer. For example, the US military including the U.S. Air Force and Navy now require that their new buildings be LEED green buildings. This may be in part because they recognize the linkage between wasteful energy consumption and the exposure of U.S. military forces to military confrontation

related to oil resources. As Boston Mayor Thomas M. Menino eloquently put it, "High performance green building is good for your wallet. It is good for the environment. And it is good for people." In a 2006 survey of developers by McGraw-Hill Construction respondents reported they expected to see occupancy rates for green buildings 3.5% higher than market norms and rent levels to increase by 3%. Operating costs are estimated to be 8 to 9% lower, as well. These numbers are getting the attention of developers and investors which is driving the growth of today's ecoconstruction. And according to Rick Fedrizzi, CEO and founding chair, USGBC, "Green building is playing a massive role in the U.S. construction sector, the clean and efficient energy sector and the U.S. economy as a whole," and "More than 2.3 million U.S. workers are taking home \$134 billion annually in large part because of green building programs like LEED. Demand for green building will only continue to grow as individuals, businesses and institutions continue to prioritize sustainable approaches to the design, construction and operations of our built environment." Fedrizzi goes on to say, "Green buildings are a hallmark of economically sound business decisions, thoughtful environmental decisions, and smart human impact decisions." "Economically sound" is the key. Designing sustainably makes sense both in terms of dollars and cents, and in terms of taking care of our environment for future generations.

To this CalRecycle adds, "A green building may cost more up front, but saves through lower operating costs over the life of the building. The green building approach applies a project life cycle cost analysis for determining the appropriate up-front expenditure. This analytical method calculates costs over the useful life of the asset." It goes on to say that "These and other cost savings can only be fully realized when they are incorporated at the project's conceptual design phase with the assistance of an integrated team of professionals. The integrated systems approach ensures that the building is designed as one system rather than a collection of stand-alone systems." During the past decade, we have witnessed a rapid emergence of ecoconstruction that reflects the building industry's growing confidence that the extra costs of building green are a good investment. Although the up-front costs of building green may be higher than using conventional materials, that premium is shrinking. Precise benefits such as reduced energy bills and reduced potable water consumption can easily be computed, whereas other benefits such as green design's impact on occupant health or security are usually much more difficult to quantify.

Incisive Media's "2008 Green Survey: Existing Buildings" found that nearly 70% of commercial building projects in the United States have already incorporated some kind of energy monitoring system. The survey also found that energy conservation is the most widely implemented green program in commercial buildings; this is followed by recycling and water conservation. Moreover, approximately 65% of building owners who have implemented green building features claim their investments have already resulted in a positive return on their investment. The return on investment (ROI) is expected to improve even further as the market for green materials and design expertise grows and matures. In this respect, Taryn Holowka, Director of Marketing & Communications, USGBC, claims, "the supply of materials and services is going up and the price is coming down."

Turner Construction Company's 2008 Green Building Barometer notes that approximately 84% of respondents maintain that their green buildings have resulted in lower energy costs, and 68% recorded lower overall operating costs. Likewise, "75% of executives said that recent developments in the credit markets would not make their companies less likely to construct Green buildings." In fact the survey contends that 83% would be "extremely" or "very" likely to seek LEED certification for buildings they are planning to build within the next 3 years. In the same survey, executives reported that Green buildings generally have better financial performance than non-Green buildings, especially in the following sectors:

- Higher building values (72%)
- Higher asking rents (65%)
- Greater ROI (52%)
- Higher occupancy rates (49%)

This is confirmed by Jerry Jackson of Texas A&M University who says that "A growing body of empirical literature indicates that LEED and ENERGY STAR-certified buildings do command higher rents and greater occupancy rates relative to conventional buildings. For example, rent premium estimates from four recent studies using the CoStar national real estate database range from 4.4% to 51%. Occupancy premiums range from 4.2% to 17.9%. Each of these studies attempted to control for other factors such as building age." Another similar study contends that 60% of commercial building owners offer education programs to assist tenants in carrying out green programs in their space, reflecting a growing understanding of the significance of environmental awareness among employees and customers in addition to the use of green materials and systems application.

Davis Langdon (2007) also conducted a comparative study in 2006 in which the construction costs of 221 buildings were analyzed, and it was found that 83 buildings were constructed with the intent of achieving LEED certification and 138 that lacked any sustainable design intentions. The study found that a majority of the buildings analyzed were able to achieve LEED certification without increased funding. In another investigation conducted by Davis Langdon of a wide and diverse range of studies by other organizations found that the average construction cost premium required to achieve a moderate level of Green features, equivalent to a Silver LEED certification, was roughly between 1% and 2%. However, what is particularly interesting is that it was also found that half or more of the Green projects in these studies often revealed a zero increase in construction costs.

Yet even with the increased awareness of the benefits for sustainable design, some property owners and developers are sometimes slow off the mark to embrace green building practices. As Jerry Jackson points out, "Considering this information from the developer's perspective would seem to make the choice of sustainable versus conventional project development a rather easy choice. However, developer views of sustainable building projects are considerably less enthusiastic. A recent survey by Building Design and Construction in August 2007 found that while 94% of respondents thought the trend in sustainable building projects was "growing," 78% thought sustainable design added "significantly to first costs." Thirty-two percent of respondents estimated additional costs to be from 6% to 10%, while 41% estimated sustainable construction premiums to be 11% or greater."

This also appears to be the prevailing sentiment of CB Richard Ellis' "Green Downtown Office Markets: A Future Reality," a report depicting the general progress of the green building movement. The report scrutinizes the obstacles preventing a broad-based acceptance of sustainable design in office construction. Perhaps the main obstacle to embracing design sustainability is the perception of initial outlay compared to long-term benefits; even though an increasing number of studies similar to the one conducted by Davis Langdon in 2006 clearly conclude that there is no significant difference in average costs for green buildings as compared to conventionally constructed buildings. Another hurdle that requires addressing is the lack of sufficient data on development, construction costs, and time needed to recoup costs. Nevertheless, there is a recent CBRE white paper which states that preliminary studies show that building a property to receive basic LEED certification can be achieved with zero additional cost. "However,

building a greener building—designed to achieve one of the higher standards of accreditation—is likely to add somewhere between 5% and 7.5% to construction costs.”

There seems to be insufficient interest today in conducting research relating to green building in the United States. Such research currently constitutes an estimated \$193 million per year or roughly 0.2% of federally funded research (according to a 2007 USGBC report). This approximates a mere 0.02% of the estimated \$1 trillion value of annual U.S. building construction at the time, despite the fact that the building construction industry represents approximately 9% of the US GDP. It is unfortunate that the construction industry can only manage to currently reinvest only 0.6% of sales back into research. This is markedly less than the average for other U.S. industries and private sector construction research investments in other industrialized countries around the world. However, Chris Pyke, director of research at the USGBC, says that in recent years, there has been a significant increase in federal funding for green building research. To varying degrees, he says, the DOE and EPA now recognize that green building issues are legitimate topics of research. The USGBC, after publishing a report detailing the low levels of federal investment in green-building research, responded by investing \$2 million to create the Building Research Fund, a one-time grant to raise awareness of the need for research.

Various green organizations are strongly suggesting that unless we move decisively toward increasing and improving green building practices, we are likely to soon be confronted with a dramatic backlash in adverse impact of the built environment on human and environmental health. Building operations today are estimated to account for 38% of U.S. carbon dioxide emissions, 71% of electricity use, and 40% of total energy use. If the energy required in the manufacture of building materials and constructing buildings is included, this number then goes up to an estimated 48%. Buildings also consume roughly 12% of the country’s water in addition to rapidly increasing amounts of land. Moreover, construction and remodeling of buildings account for three billion tons, or 40%, of raw material used globally each year, which in turn has a negative impact on human health; in fact, up to 30% of new and remodeled buildings may experience acute indoor air quality problems such as Sick Building Syndrome (SBS). But as is the case with most projects, determining building strategies early in the design process and sticking with those decisions can result in the most efficient cost models for building. Implementing a goal-setting session at the beginning

of each project to determine appropriate strategies and levels of cost and time investments can result in lower sustainable design construction costs.

An appropriate analysis of green construction costs can be achieved through the application of several methods. For example, it is possible to use the LEED Rating System or the Green Globes rating system as benchmarks for success. Higher levels of certification may carry increased costs, but empirical market data suggest that the “Certified” and “Silver” levels with the LEED system and one or two “Globes” with the Green Globes system carry little or no premium over traditional building costs for most building types. Specialty project types, such as health care or research, often have program criteria and specific needs that are at odds with the principles of sustainable design, primarily as it relates to energy usage and in environmental constraints.



10.2 COSTS AND BENEFITS OF GREEN DESIGN

Although the benefits of green building are substantial and have been known for many years, many developers and investors remain concerned and want to know, “at what cost,” and how will building green benefit the financial viability of their investment? In this respect, Peter Morris opines that, “clearly there can be no single, across-the-board answer to the question, ‘what does green cost?’ On the other hand, any astute design or construction professional recognizes that it is not difficult to estimate the costs to go green for a specific project. Furthermore, when green building concepts and features are incorporated early in the design process, it greatly increases the ability to construct a certified green building at a cost comparable to a code compliant one. This means that it is possible today to construct green buildings or buildings that meet the US Green Building Council’s (USGBC) Leadership in Energy and Environmental Design (LEED™) third party certification process with minimal increase in initial costs.” (Fig. 10.1).

For LEED certification, early studies (LEED v2) suggest that conventionally constructed buildings can often qualify for 12 or more LEED points by virtue of current building standards and inherent design qualities. In many cases, between 15 and 20 additional points can be achieved with little to no additional costs, qualifying most buildings for the minimum rating classification. As mentioned previously, some studies concluded that the cost of achieving Silver certification varies between 2 and 6% above traditional construction, although there are also studies that suggest in today’s market

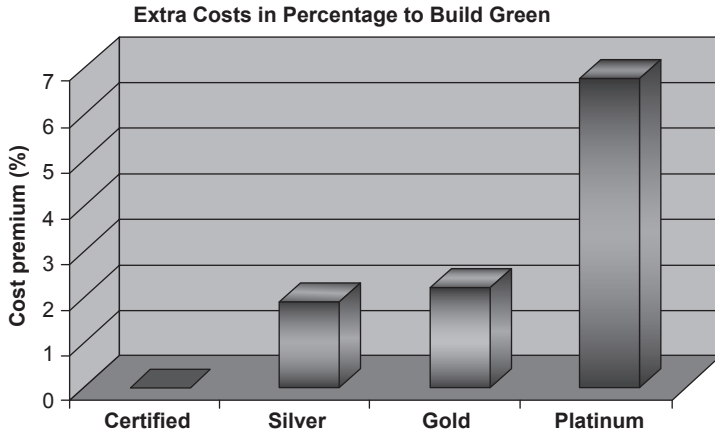

Figure 10.1 Diagram showing one study's estimated cost of building green for the various LEED rating systems. *Source: USGBC.*

there may be no increase in cost. However, to achieve the higher levels of certification, Gold and Platinum, there may be some additional costs to the project, primarily due to the costs of applying increasing efficient technologies for water conservation and energy performance. But these costs are more than balanced out by the benefits achieved over the lifecycle of the project. This is why it is important to understand why the evolution LEED is so critical to the transformation of the building industry, connecting the market to innovative ways of thinking about the design, construction, and operation of green buildings. The power of LEED is its ability to transform. With LEED 2009, for example, the primary changes were foundational ones, such as rating system content alignment, the development of LEED Online v3 and changes to the professional credentials and certification process. With the latest version, LEED v4 builds on the changes set forth in LEED 2009 but also focuses on improving the user experience, and providing measurement and performance tools to actually test and verify the performance of LEED-certified buildings. Of note, the USGBC has allowed project teams to register for either LEED v4 or LEED 2009 until October 31, 2016, after which only LEED v4 remains open.

We have also yet to fully comprehend how the new IgCCs will impact this equation, especially since the IgCC is the first national green model code in the United States. According to its website, the new IgCC code is intended to provide minimum requirements to protect the environment, public health, safety, and general welfare as well as to minimize the negative impacts produced and to increase positive impacts of the built environment,

the natural environment, and building occupants. For the latest updates of the IgCC requirements and benefits, visit the IgCC website (<http://www.iccsafe.org/codes-tech-support/codes/2015-i-codes/igcc/>). The IgCC applies to all occupancy types, except low-rise residential buildings under the International Residential Code.

Global construction consultant, Davis Langdon suggests that to be successful in building green and to keep the costs of sustainable design under control, three critical factors must be understood and implemented, they are:

1. Clear goals are critical for managing the cost. It is insufficient to simply state, “we want our project to be green”; the values should be determined and articulated as early in the design process as possible.
2. Once the sustainability goals have been defined, it is essential to integrate them into the design and to integrate the design team so that the building elements can work together to achieve those goals. Buildings can no longer be broken down and designed as an assemblage of isolated components. This is the major difference between traditional building techniques and the new sustainable design process.
3. Integrating the construction team into the project team is critical. Many sustainable design features can be defeated or diminished by poor construction practices. Such problems can be eliminated by engaging the construction team, including subcontractors and site operatives in the design and procurement process.

Greening Buildings and Communities: Costs and Benefits, is another important study reflecting the largest international research of its kind, and which is based on extensive financial and technical analysis of 150 green buildings across the United States and in 10 other countries and provides the most detailed findings to date on the costs and financial benefits of building green. This study found that benefits of building green consistently outweigh any potential cost premium. The main conclusions it arrived at include:

1. Most green buildings cost 0–4% more than conventional buildings, with the largest concentration of reported “green premiums” between 0–1%. Green premiums increase with the level of greenness, but most LEED buildings, up through gold level, can be built for the same cost as conventional buildings. This stands in contrast to a common misperception that green buildings are much more expensive than conventional buildings.
2. Energy savings alone make green building cost effective. Energy savings alone outweigh the initial cost premium in most green buildings. The present value of 20 years of energy savings in a typical green office

ranges from \$7 per square foot (certified) to \$14 per square foot (platinum), more than the average additional cost of \$3 to \$8 per square foot for building green.

3. Green building design goals are associated with improved health and with enhanced student and worker performance. Health and productivity benefits remain a major motivating factor for green building owners but are difficult to quantify. Occupant surveys generally demonstrate greater comfort and productivity in green buildings.
4. Green buildings create jobs by shifting spending from fossil fuel-based energy to domestic energy efficiency, construction, renewable energy, and other green jobs. A typical green office creates roughly one-third of a permanent job per year, equal to \$1 per square foot of value in increased employment, compared to a similar nongreen building.
5. Green buildings are seeing increased market value (higher sales/rental rates, increased occupancy, and lower turnover) compared to comparable conventional buildings. CoStar, for example, reports an average increased sales price from building green of more than \$20 per square foot providing a strong incentive to build green even for speculative builders.
6. Roughly 50% of green buildings in the study's data set see the initial "green premium" paid back by energy and water savings in 5 years or less. Significant health and productivity benefits mean that over 90% of green buildings pay back an initial investment in 5 years or less.
7. Green community design (e.g., LEED-ND) provides a distinct set of benefits to owners, residents, and municipalities, including reduced infrastructure costs, transportation and health savings, and increased property value. Green communities and neighborhoods have a greater diversity of uses, housing types, job types, and transportation options and appear to better retain value in the market downturn than conventional sprawl.
8. Annual gas savings in walkable communities can be as much as \$1000 per household. Annual health savings (from increased physical activity) can be more than \$200 per household. CO₂ emissions can be reduced by 10–25%.
9. Up-front infrastructure development costs in conservation developments can be reduced by 25%, approximately \$10,000 per home.
10. Religious and faith groups build green for ethical and moral reasons. Financial benefits are not the main motivating factor for many places of worship, religious educational institutions and faith-based nonprofits. A survey of faith groups building green found that financial cost

effectiveness of green building makes it a practical way to enact the ethical/moral imperative to care for the Earth and communities. Building green has also been found to energize and galvanize faith communities.

Even when green building up-front costs exceed what was originally estimated due primarily to inefficient planning and execution, these costs can be quickly recouped through lower operating costs over the life of the building.

10.2.1 Economic Benefits of Green Building

The economic benefits of green building cannot be overemphasized, but that to achieve maximum cost savings, green design strategies need to be incorporated at the project's conceptual design phase in collaboration with an integrated team of professionals. Using an integrated systems approach ensures that the building is designed in a holistic manner as one system rather than a number of stand-alone systems as is normal with conventional methods. The challenge here is that not all green building benefits are easy to quantify; for example, how do you measure improving occupant health, comfort, productivity, or pollution reduction? This is why they are excluded from being adequately considered in cost analysis. It would appear to be prudent therefore by considering to setting aside a small portion of the building budget (e.g., as a contingency) to cover differential costs associated with less tangible green building benefits or to cover the cost of researching and analyzing green building options. Even when experiencing difficult times, many green building measures can be incorporated into a project with minimal or zero increased up-front costs. Yet this would be capable of yielding substantial savings and other benefits (Fig. 10.2) over the life of the facility.

No matter how interested an owner or developer is in green building and sustainability, the bottom line remains, what does "green" cost?; typical translation: does it cost more? This then raises the question: more than what? For example, is the question more than what the building would have cost without the sustainable design features than that of comparable buildings, or is the question, more than available funds? The answers to these questions have until recently been largely elusive due to the lack of hard data. Over recent years, however, we have seen various organizations conduct considerable research into green building and sustainability costs, etc. We now have a substantial databank on building costs that allows us to compare the costs of green buildings and traditional nonsustainable buildings with comparable characteristics.

↑ increasing benefit									
	Occupant	Neighbor	Owner	Developer	Designer	Investor / Lender	Municipal Government	Provincial Government	Federal Government
Economic	Dark	Light	Light	Light	Light	Light	Light	Light	Light
Occupant Health	Dark	Light	Light	Light	Light	Light	Light	Light	Light
Risk Reduction	Light	Light	Dark	Light	Light	Light	Light	Light	Light
Climate Change Impact	Light	Light	Light	Light	Light	Light	Light	Light	Light
Ecological	Light	Light	Light	Light	Light	Light	Light	Light	Light
Decreased Infrastructure Reliance	Light	Light	Light	Light	Light	Light	Dark	Light	Light
Occupant Comfort	Dark	Light	Light	Light	Light	Light	Light	Light	Light

Figure 10.2 Matrix illustrating various green building stakeholder benefits. *Source: Report - A Business Case for Green Buildings in Canada.*

To adequately assess sustainable design and how it relates to construction costs, it is imperative to analyze the costs and benefits using a holistic approach. This basically means including evaluation of operations and maintenance costs, user productivity and health, design and documentation fees, among other financial measurements. This is largely because empirical experience continues to demonstrate that it is the construction cost implications that have the greatest impact to fundamentally determine decisions about sustainable design. By helping teams to really understand the actual construction costs of real projects that are achieving green, and by providing a methodology that allows teams to viably manage these construction costs can go a long way to facilitate a team’s ability to get past the question of whether or not green is the answer. Green construction is helped by the fact that the cost of green design has dropped significantly in the last few years as the number of green buildings has increased. The trend of declining costs associated with increased experience in green building construction

has manifested itself in a number of states throughout the country. From such an analysis, it can be concluded that many projects are able to achieve sustainable design within the initial budget, or with minimal supplemental funding. This suggests that developers continue to find ways to incorporate project goals and values, regardless of budget, by making choices. However, every building project is unique and should be considered as such as there is no one-size-fits-all answer and benchmarking with other comparable projects can be valuable and informative, but not predictive. Any estimate of cost relating to sustainable design for a specific building must be made with reference to that building, its objectives, and particular circumstances and attributes.

In a recent study by Greg Kats of Capital E Analysis (Table 10.1), we see a summary of some of the financial benefits from going green. The report concludes that financial benefits for building green are estimated to be between \$50 and \$70 per square foot in a LEED-certified building; this represents more than 10 times the additional cost associated with building green. These financial benefits come in the form of lower energy costs, waste and water costs, lower environmental and emissions costs, and lower operational and maintenance costs, lower absenteeism, increased productivity and health, greater retail sales, and easier reconfiguration of space resulting in less downtime and lower costs. Cost estimates which are based on a sample of 33 office and school buildings suggested only 0.6% greater costs for LEED certification, 1.9% for silver, 2.2% for gold, and 6.8% for platinum certification. Although these estimates are direct costs, they, nevertheless, closely reflect those provided by the USGBC. What is perhaps surprising is that other than LEED, not many studies have been undertaken with regard to other rating systems such as Green Globes.

Table 10.1 Financial benefits of green buildings—summary of findings (per ft.²)

Category	20-year net present value
Energy savings	\$5.80
Emissions savings	\$1.20
Water savings	\$0.50
Operations and maintenance savings	\$8.50
Productivity and health Value	\$36.90–\$55.30
Subtotal	\$52.90–\$71.30
Average extra Cost of building green	(–3.00 to –\$5.00)
Total 20-year net benefit	\$50–\$65

The financial benefits of going green are related mainly to productivity.
Source: Capital E. Analysis.

The principal motivators that can impact the Long-term Value of Green Building appear to be:

1. Increasing Energy Costs (75%),
2. Government Regulations/Tax Incentives (40%), and
3. Global Influences (26%).

The absence of adequate clear credible data pertaining to development, construction costs, and time required to recoup costs are the most obvious challenges and obstacles accounting for the industry's sometimes lethargic acceptance of green construction, which is why education has become the most important tool in promoting green construction strategies. The main obstacles measured in the Kats study include:

- Too multidisciplinary—41%
- Not convinced of increased ROI—37%
- Lack of understanding benefits—26%
- Lack of service providers—20%
- Too difficult—17%
- Greenwashing—16%
- Lack of shareholder support—10%

Most building owners and developers have one main objective, to build a project and then sell it, in the sense that they construct or revamp an office building, lease its space, and with the hope or calculation of selling the asset within a 3 to 5-year time frame to repay debts and ensure a profit. The speed with which the process is completed impacts the amount of profit generated upon execution of the sale of the building. Uninformed developers that are under the false perception that green construction costs more can trigger fears since they are already concerned about the cost of short-term debt and conventional building materials. According to Davis Langdon, typical benefits for building owners and tenants alike include:

- Ability to command higher lease rates
- Reduced risk of building obsolescence
- Potential higher occupancy rates
- Higher future capital value
- Less need for refurbishment in the future
- Higher demand from institutional investors
- Lower operating costs
- Mandatory for government tenants
- Lower tenant turnover
- Enhance occupant comfort and health
- Improve interior air quality (IAQ); increase employee productivity and satisfaction

Finally, it is important to fully comprehend the economic impact that Green Building and sustainability has already had on the U.S. economy. As David Erne, a Senior Associate at Booz Allen said, “Our research shows that green building has created millions of jobs and contributed hundreds of billions of dollars to the US economy, with the construction of LEED-certified buildings accounting for about 40% of green construction’s overall contribution to GDP in 2015,” “This industry is certainly on the rise, and aggressive growth in the green building sector is anticipated over the next four years.”

10.2.2 Cost Considerations of Green Design

There are basically two categories of costs when discussing green buildings; these are Direct Capital Costs and Direct Operating Costs which are explained below:

Direct Capital Costs are costs associated with the original design and construction of the building and generally include interest during construction (IDC). There is a general misperception of some building stakeholders that the capital costs of constructing green buildings are significantly higher than those of conventional buildings, whereas many others within the green building field believe that green buildings actually cost less or no more than conventional buildings. Empirical evidence shows that savings are achieved by the downsizing of systems through better design and the elimination of unnecessary systems which will offset any increased costs caused by implementing more advanced systems. Capital and operational costs are normally relatively easy to measure, because the required data are readily available and quantifiable. Productivity effects on the other hand are difficult to quantify, yet are, nevertheless, important to consider due to their potential impact. There are other indirect and external effects that can be wide reaching, and which quantifying may prove difficult.

Direct Operating Costs include all applicable expenditures required to operate and maintain a building over its full life. Included are the total costs related to building operation, such as energy use, water use, insurance, maintenance, waste, property taxes, etc. over the entire building life. The primary costs are those associated with heating and cooling and maintenance activities such as painting, roof repairs, and replacement. Included in this cost category are less obvious items such as churn (the costs of reconfiguring space and services to accommodate occupant moves). All costs relating to major renovations, cyclical renewal, and residual value or demolitions costs are excluded from this category.

Insurance is essentially a direct operating cost (is discussed in greater detail in [Chapter 16](#)), and green buildings have many tangible benefits that reduce or mitigate a variety of risks, and which should be reflected in the insurance rates for the building. Likewise, the fact that green buildings generally provide healthier environment for occupants should be reflected in health insurance premiums. Indeed, the general attributes of green buildings (e.g., the incorporation of natural light, off grid electricity, and commissioning) should reduce a broad range of liabilities, and the general site locations also potentially reduce risks of property loss due to natural disasters. Furthermore, a fully integrated design of a building will typically reduce the risk of inappropriate systems or materials being employed, which could have a positive impact on other insurable risks. Insurance companies sometimes offer premium reductions for certain green features, such as commissioning or reduced reliance on fossil fuel-based heating systems. The list of premium reductions will undoubtedly increase with further education and awareness and as the broad range of benefits are more fully recognized and understood. In any case, prior to taking out a policy, it would be advisable to consult an insurance agent or attorney.

Churn rate reflects the frequency with which building occupants are moved, either internally or externally, including occupants who move but remain within a company, and those who leave a company and are replaced. It has been found that because of increased occupant comfort and satisfaction, green buildings typically have lower churn rates than conventional buildings.

10.2.3 Increased Productivity

The positive effect on productivity is but one of the many benefits that Green buildings can offer. There are numerous studies that clearly illustrate that green buildings have a dramatic effect on productivity. However, because these studies are often broad in nature and rarely focus on unique green building attributes, they need to be supplemented by other thorough, accurate, and statistically sound research to fully comprehend the effects of green buildings on occupant productivity, performance, and sales. The difficulty of properly attributing such gains like reduced absenteeism, staff turnover rates, appears to have made this the exception rather than the rule. It seems prudent, however, that any productivity gains attributable to a green building should be included in the life cycle cost analysis, particularly for an owner-occupied building. Key features of green buildings relating to increased productivity are possible due to controllability of systems relating

to ventilation, temperature, and lighting; daylighting and views; natural and mechanical ventilation; pollution-free environments; and vegetation. It is not always clear why these features produce improved productivity, although studies show healthier employees typically means happier employees which in turn creates increased worker satisfaction, improved morale, increased productivity, and reduced absenteeism.

Lawrence Berkeley National Laboratory recently conducted a study to highlight the potential ramifications of building green and concluded that improvements to indoor environments such as commonly found in green buildings can help reduce health care costs and work losses as follows:

- from communicable respiratory diseases by 9–20%
- from reduced allergies and asthma from 18 to 25%
- from nonspecific health and discomfort effects by 20–50%

Hannah Carmalt, a Project Analyst with Energy Market Innovations, notes that, “The most intuitive explanation is that productivity increases due to better occupant health and therefore decreased absenteeism. When workers are less stressed, less congested, or do not have headaches, they are more likely to perform better.” High-performance buildings have many potential benefits including increased market value, lower operating and maintenance costs, improved occupancy for commercial buildings, and increased employee satisfaction and productivity for owner-occupied buildings.

A study by William Fisk concluded that green buildings added \$20 to \$160 billion in increased worker productivity annually. This is due to the fact that LEED-certified buildings were found to yield significant productivity and health benefits, such as heightened employee productivity and satisfaction, fewer sick days, and fewer turnovers. Moreover, other independent studies have shown that better climate control and improved air quality can increase employee productivity by an average of 11–15% annually. Still, it is necessary to define the particular elements of green buildings that are directly related to productivity. Sound control, for example, while recognized as increasing productivity, is often excluded from green-related studies, mainly because it is not considered to be particularly a green building feature. Likewise, the presences of biological pollutants, such as molds are also associated with decreased productivity; yet these are also excluded because typical green buildings do not automatically eliminate the presence of such pollutants even though their presence is reduced because of improved ventilation in green buildings. However, it should be noted that in commercial and institutional buildings, payroll costs generally significantly

overshadow all other costs, including those involved in a building's design, construction, and operation costs.

In today's world, occupant control has become one of the most significant elements of green buildings that affect productivity and thermal comfort; control is required over temperature, ventilation, and lighting. Green buildings usually try to incorporate this feature because it can noticeably decrease energy use by ensuring areas are not heated, cooled, or lit more than is necessary. These measures are decisive to maintaining energy efficiency and occupant satisfaction within a building. Increased productivity has often been associated with increased emotional well being as various studies have clearly shown. A study conducted by the Heschong Mahone Group (HMG) found that higher test scores in daylight classrooms were achieved due to students being happier. HMG also found that when teachers were able to control the amount of daylighting in classrooms, students appeared to progress 19 to 20% faster than students in classrooms who lacked controllability. Similar studies performed in office settings clearly showed that there was a significant rise in productivity when there was individual control over temperature, lighting, and ventilation.

A view to the outdoors is another common feature of green buildings that is associated with productivity in office space. The office study conducted by HMG mentioned previously, confirmed correlations between productivity and access to outdoor views: test scores were generally 10–15% higher and calling performance increased by 7–12%. This reinforces HMG's earlier 1999 study findings of schools where children in classrooms of the Capistrano School District progressed 15% faster in math and 23% faster in reading when they were located in the classrooms with the largest windows.

Ventilation can be of paramount importance because it facilitates the introduction of fresh air to cycle through the building and removing stale or pollutant air from the interior. Germs, molds, and various VOCs, such as those emitted by paints, carpets, and adhesives, can be often be found within buildings lacking adequate ventilation, causing SBS. Typical symptoms include inflammation, asthma, and allergic reaction. Ventilation can also play a critical role in worker productivity, as evidenced by the extensive research that has been conducted to address these issues. This is also why it is imperative to minimize the use of toxic materials inside the building. Many of the products used in conventional office buildings, such as carpets, and copying machines contain toxic materials and minimizing them decreases the potential hazards associated with them and their disposal. Furthermore, because these materials are known to leak pollutants into the indoor air,

proper ventilation is required to avoid an adverse impact on worker productivity. But from the above, it becomes evident that productivity can be impacted by many factors, all of which can influence the bottom line. Moreover, it has been shown that there is less staff turnover when employees are satisfied which in turn helps improve the overall productivity of a firm. Less time spent on job training allows more time to be spent on being productive. Staff retention is one of the decisive factors why many firms take the decision to green their office buildings in today's competitive world.

Committing to a market value for occupant productivity gains and have them accurately reflected in the business case at the decision-making point is not easy in the case of speculative or leased facilities. In any case, there is now adequate data and evidence quantifying the effects to support taking them into account on some basis. And while an owner of a leased facility may not financially benefit directly from increased user productivity, there could be indirect benefits in the form of increased rental fees and occupancy rates. For the majority of commercial buildings, the use of a conservative estimate for the potential reduction in salary costs and productivity gains will loom large in any calculation.

10.2.4 Improved Tenant/Employee Health

Navigant Research points out that the facilities industry is experiencing a dramatic transformation. This appears to be influenced by many factors including an aging workforce, varying expectations from tenants and employees, and increased pressures on sustainability and efficiency. This transformation is opening the door to intelligent building systems or "smart" buildings. In this respect, Navigant Research also says that advanced sensors are playing a critical role in transforming facilities into intelligent buildings, and furthermore Navigant Research forecasts global advanced sensor revenue will grow from \$1160.3 million in 2016 to \$3221.9 million in 2025 at a 12% compound annual growth rate.

Most architects and property developers and owners are well aware that superior air quality is one of the principal attributes of green buildings which normally include other features such as abundant natural light, access to views, and effective noise control. Each of these qualities is for the benefit of building occupants, making these building better places to work and live. Building occupants are increasingly seeking many green building features, such as superior air quality, control of air temperatures, and views. The Urban Land Institute (ULI) and the Building Owners and Managers Association (BOMA) conducted a survey which found that occupants rated



Figure 10.3 LEED-certified buildings are known to provide healthier work and living environments. Photo of interior space in Ohlone College, Newark Center for Health Sciences and Technology, Newark, CA, which received LEED Platinum. *Source: Turner Construction, 2008. Green Building Market Barometer. www.turnerconstruction.com/greenbuildings.*

air temperature (95%) and air quality (94%) most crucial in terms of tenant comfort. The study also determined that 75% of buildings did not have the option or capability to adjust features and that many individuals were willing to pay higher rents to obtain such features. These features were the only ones that were considered “most important” and on the list with which tenants were least satisfied. This study also determined that the principal reasons why tenants move out include heating or cooling problems.

Natural light, clean air, and thermal comfort are required elements to stay healthy and productive, in addition to providing an enjoyable living and work environment (Fig. 10.3). The number of credible studies demonstrating an intrinsic connection between green building strategies and occupant health and well-being is endless. William Fisk in a 2002 study “How IEQ Affects Health, Productivity” estimates that 16–37 million cases of colds and flu could be avoided by improving indoor environmental quality. This translates into a \$6–\$14 billion annual savings in the United States while at the same time reducing SBS symptoms (a condition whereby occupants become temporarily ill), by 20–50%, resulting in annual savings of \$10–\$30 billion.

10.2.5 Increased Recruitment and Retention

Harris Interactive recently conducted a national survey, and concluded that more than a third of U.S. workers would be further inclined to work for companies with strong green credentials and highlighted the growing influence of environmental issues over staff recruitment and retention policies. This is further confirmed by Timothy R. Johnson, a principal at GCA International, who notes, “Firms that focus on the growing market sector of green building and sustainable design will be

more attractive to top-notch candidates for reasons of recognized work-load availability, progressive growth, and employment stability.” This is clear evidence that providing a healthy and pleasant work environment increases employee satisfaction, productivity, and retention. It also clearly increases the ability to compete for the most qualified employees as well as for business.

Statistical data and other evidence leaves no doubt that high-performance green buildings can increase a company’s ability to recruit and retain employees due to many factors such as good air quality, abundant amounts of natural light, and better circulated heat and air conditioning, all of which help provide a more pleasant, healthier, and more productive places to work in. With this in mind, it is surprising that willingness to join and remain with an organization is an aspect often overlooked when considering how green buildings affect employees. The economics of employee retention is important to seriously consider as one estimate puts the cost of losing a single good employee is roughly between \$50,000 and \$150,000, and many organizations experience a 10 to 20% annual turnover, some of it from persons they would have really liked to retain. In a workforce of say 100 people, turnover at this level implies 10–20 people leaving per year. In some cases people decide to leave due to poor physical and working environments. [Fig. 10.4](#) compares the difference in occupancy rates between Energy Star and non-Energy Star buildings.

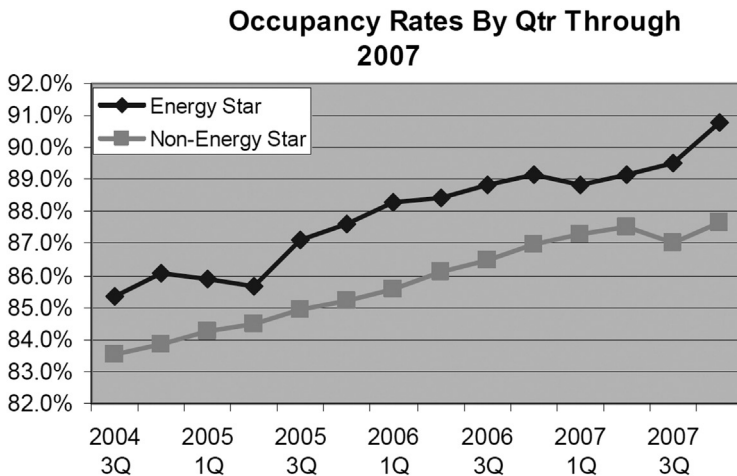

Figure 10.4 Diagram comparing the occupancy rates of two types of buildings—energy star and non-energy star. *Source: Does Green Pay Off? By Norm Miller, Jay Spivey and Andy Florance.*

10.2.6 Increased Property Values and Marketability

The number of reliable studies that have been conducted on the intrinsic relationship between property values and green buildings is rather limited, even though this is an important aspect that should be quantified and included in the economic calculations. There are many factors that will or could increase property values for green buildings. Indeed, enhancement of property value is a key factor for speculative developers who fail to directly achieve operating cost and productivity savings. It is an element of particular relevance to speculative developers who intend to either sell or lease a new building, although it can also have a bearing on the decision process in general, including developers who intend to occupy a building while maintaining an eye on the market value of the asset. Many in the real estate industry unfortunately remain oblivious to the real benefits of green buildings, due to a lack of adequate education in sustainability, and therefore cannot fully convey these benefits to prospective purchasers or prospective tenants.

However, LEED-certified buildings with lower operating costs and better indoor environmental quality are known to be more attractive to a growing group of corporate, public, and individual buyers. High-performing building features are increasingly entering into tenants' decisions about leasing space and into buyers' decisions about purchasing properties and homes. For example, recent studies confirm that, as of January 2015, the market for houses with green certifications is 10–14% more than for comparable homes without them (Alan J. Heavens, “‘Green’ home certifications are bringing more greenbacks,” *The Philadelphia Inquirer*). Other industry research has noted that improved health and productivity benefits are playing an increasing role in encouraging companies to invest in green building today than they have said, a decade ago. Also regarding commercial buildings, the Deloitte Center for Financial Services in their 2015 Commercial Real Estate Outlook confirm that the value of a green building increases when compared with a traditional building. The Center states, “Sustainability initiatives have a significant bearing on CRE (commercial real estate) operations, which manifest themselves in various forms—environment, portfolio performance, top and bottom line, asset values, stakeholder engagement and brand perception. Among other things, buildings with relatively better sustainability credentials tend to enjoy increased market-ability to both tenants and investors.”

Jerry Yudelson, a well-known green scholar maintains that increased annual energy savings have been found to promote higher building values,

and cites as an example, a 75,000-sq-ft. building that saves \$37,500 per year in energy costs versus a comparable building built to code (This savings might result from saving of 50 cents per square foot per year). At capitalization rates of 6%, typical today in commercial real estate, green-building standards would add \$625,000 (\$8.33 per square foot) to the value of the building. This means that for a small up-front investment, an owner can reap benefits that typically offer a rate of return exceeding 20% with a payback of 3 years or less. The fact that high-performance buildings can offer building owners many important benefits ranging from higher market value to more satisfied and productive employee occupants is not always apparent. The primary reason for this is that majority of the benefits accrue to tenants, and tenants usually need proof before they are willing to participate in the cost of investments that are perceived will help them be more productive or save money. It is only very recently due mainly to increased awareness, that tenants have started to fully appreciate the benefits of cleaner air, more natural lighting and flexible spaces that can be modified as and when required.

All the available evidence points to the fact that green buildings, particularly with good quality natural lighting, can have a dramatic effect on property value and sales with respect to commercial buildings. Furthermore, without exception, several American studies report that there is a sound economic basis for green buildings, but only when operational costs are included into the equation. More specifically, whole building studies conclude that the net present values (NET) for pursuing green buildings as opposed to conventional buildings ranges from \$50 to \$400 per square foot (\$540 to \$4300 per square meter). The NET depends on a building's length of time analyzed (e.g., 20–60 years) and the degree to which the buildings implement green strategies. One of the main conclusions from these studies is that generally, that the NET increases as the greenness of the building increases. A CoStar study found that with regard to rental sales, LEED buildings can command rent premiums of about \$11.24 per square foot versus their conventional peers in addition to a 3.8% increase in occupancy rate. The study also found that rental rates in ENERGY STAR buildings can boast a \$2.38 per square foot premium versus comparable non-ENERGY STAR buildings in addition to a 3.6% greater occupancy rate. However, what is perhaps more remarkable and what may prove to be a trend that could signal greater attention from institutional investors, is that LEED buildings are commanding a surprising \$171 more per square foot than their conventional counterparts, and ENERGY STAR buildings are commanding an

average of \$61 per square foot more. This is quite extraordinary since most leasing arrangements, particularly in the office/commercial sectors, provide little incentive to undertake changes that might be construed as being beneficial to the environment. For example, leases often have fixed rates with no regard to energy or water consumption, even though the lessees have control over most energy and water consuming devices.

10.2.7 Miscellaneous Indirect Benefits

There are numerous indirect benefits to green building such as improved image, risk reduction, future proofing, and self-reliance. These and other similar benefits may be captured by investors and should not be discarded in decision economics considerations. Although they may be difficult to quantify and in some cases even be intangible, they should nevertheless be factored into the business case because they are intrinsically connected to sustainable design, and they can significantly impact the value of a green building.

Enhanced Image

One of the key messages conveyed by sustainable buildings is concern for the environment which is why a green building can be used as a public relations vehicle. Moreover, even if we disregard the financial benefits attributed to green buildings, they are generally perceived by the public as modern, dynamic, and altruistic. A green building serves as physical and permanent message about the commitment of an organization to environmental stewardship and accountability. Green buildings can therefore provide a strong symbolic message of an owner's commitment to sustainability. Some of the benefits that companies can enjoy from these perceptions include employee pride, satisfaction, and well-being, which often translate into reduced turnover, advantages in recruitment of employees, and improved morale. These powerful images can be a motivational factor in a company's decision to pursue occupancy in a green facility.

Reducing Risk

The recent financial uncertainty facing the American property market and the difficulty that property developers and property owners face in obtaining bank loans made some investors reluctant to make new investments. And commenting on the recent downturn in the U.S. economy, Peter Morris, Principal with Davis Langdon tells comments: "Risk remains a serious concern for construction projects. Delay and cancellation of projects,

even projects under construction, is a growing trend.” Morris also proposes a key theme for project owners in the current market turmoil which is that, “the successful adoption of a competitive procurement strategy, in order to secure lower costs, will depend on active steps by the owner and the project team to ensure that the contractor is in a position to provide a realistic and binding bid and that contractors’ bidding costs are minimized.”

Employing green building principles can mitigate many of the potential perceived risks. In this regard, the Environmental Protection Agency in the United States currently classifies indoor air quality as one of the top five environmental health risks. Increased litigation is also evidenced with regard to mold-related issues. The “Sick Building Syndrome” (SBS) and “Building-Related Illness” (BRI) are among the issues of major concern and which often end up being resolved in the courts. Business owners and operators are increasingly facing legal action from building tenants blaming the building for their health problems. The main cause of SBS and BRI is poor building design and/or construction, particularly with respect to the building envelope and mechanical systems. Green buildings should emphasize and promote not only safe, but also exceptional air quality, and no recognized green building should ever have to suffer from SBS or BRI.

Future Proofing

Green buildings are inherently efficient and safe, and as such help ensure that they will not be at a competitive disadvantage in the future (Fig. 10.5). Davis Langdon sums it very well by saying, “Going green is ‘future-proofing’ your asset.” This is largely because there are a number of important potential risks that are significantly mitigated in green buildings such as:

- Energy conservation protects against future energy price increases.
- Occupants of green buildings are generally more comfortable and contented, so it can be assumed that they will generally be less likely to be litigious.
- Water conservation shields against water fee increase.
- A documented effort to build or occupy a healthy green building demonstrates a level of due diligence that could stand as an important defense against future law suits or changes in legislation, even when faced with currently unknown problems.

Self Reliance

The fact that green buildings often incorporate natural lighting, ventilation, internal energy, and water generation, makes them less likely to rely on external grids and less likely to be effected by grid-related



Figure 10.5 Photo of building in Italy with “green façade” showing the benefits of vertical vegetation on exterior walls. There are two types of green facades: (1) that utilize climbing plants or plants secured by a trellis and contain enough soil to support the plants; and (2) living wall systems constructed of thin panels on an artificial growing medium such as felt or mineral wool, that need nutrients and water. *Photo: Anna Positano.*

problems or failures such as black-outs, water shortages, or contaminated water. This element is acquiring increasing importance globally because of the increased potential risk of terrorism. Local self reliance is steadily moving to prime time and the Institute for Local Self Reliance (ILSR) continues to develop cutting edge solutions to the problem-facing communities around the globe. Terri Wills, CEO of World GBC opines that “Green building is playing a critical role in the development of many emerging economies, particularly as their populations grow and create a pressing need for a built environment that is both sustainable and ensures a high quality of life.” This anticipated growth is additionally driven largely by countries with developing green markets, such as Mexico, Brazil, Canada, Colombia, Saudi Arabia, South Africa, China, India, and the United Arab Emirates, all of which are reporting dramatic growth in the number of projects they are expecting to see certified as green.

Below are examples of five local American communities that have recently taken steps toward energy independence. It shows that at the local

level, energy independence has become a realistic possibility as numerous communities around the United States explore available renewable resources, and the technology necessary to harness them. The five US Towns shown below are but a few of the many around the nation, creating models for clean energy production and self reliance:

- Rock Port, Missouri is a small town with a population of 1400 that has become the first community in the nation to be completely powered by wind.
- Greensburg, Kansas is rebuilding itself as a “model green town” after being hit by a disastrous tornado and which is now expecting to provide enough power to meet all the energy needs for the town in the foreseeable future.
- Reynolds, Indiana is another small Midwestern town with a population of 540 was chosen as the community to execute the state government’s “Biotown USA” experiment. The plan is to power the town on a range of locally available biomass.
- San Jose, California’s city council recently gave the city manager the authority to negotiate the terms of “an organics-to energy bio-gas facility.”
- Warrenton, Virginia like San Jose is taking the “trash into treasure” approach. Mayor George Fitch has spearheaded an effort to build a “bio-refinery” and reduce the town’s greenhouse gas emissions by 25% by 2015.

10.2.8 External Economic Effects

It is not easy to give a precise definition of external effects; they generally consist of costs or benefits of a project that accrue to society and are not readily captured by the private investor. Examples of this are reduced reliance on infrastructure such as sewers and roads, reduced green house gases, and reduced health costs, etc. The extent to which these benefits can be factored to a business case relies on the extent to which they can be converted from the external to the internal sides of the ledger. This constitutes a vital factor in any assessment of the costs and benefits of green buildings. Thus the costs of green vegetated roofs are borne by the developer or investor, while much of the benefit accrues at a broader societal level such as reduced heat island effects and reduced storm water runoff. Where the investor is a government agency, or where a private developer is compensated for including features that produce benefits at a societal level, the business case can encompass the much broader range of effects. For example, there is the state of Oregon that offers tax incentives for green building, thereby

providing a direct business case payoff to the investor. Other examples are jurisdictions such as in Arlington, Virginia which allows higher floor space to land coverage ratios for green buildings.

“Green” has become a common buzzword and journalists everywhere are writing about a “green economy,” “green technology,” and even “green” jobs. Many manufacturers are now clinging to the green bandwagon and increasingly claiming to be “green” while many others try to measure the effect of “green” technology on the job market. “Green” encourages job creation, partly because green building attributes are often labor intensive, rather than material or technology intensive. For example, there are significant environmental impacts associated with the transportation of materials for the construction industry. And by promoting the use of local and regional materials, local and regional job creation is encouraged and promoted. Buildings can be singled out to have the largest indirect environmental impact on human health. Other perhaps less critical impacts, such as damage to ecosystems, crops, structures/monuments, and resource depletion should also be considered even though they do not have a large associated indirect cost relative to human health. Infrastructure costs such as water use and disposal are typically provided by governments and are rarely cost effective or even cost neutral, and in many instances, governments are required to heavily subsidize water use and treatment. On the other hand, external environmental costs consist mainly of pollutants in the form of emissions to air, water, and land and the general degradation of the ambient environment.

Furthermore, green building can also have economic ramifications and export opportunities on a much broader scale as a result of increased international recognition and related export sales. The 2005 Environmental Sustainability Index prepared by Yale and Columbia Universities benchmarked the ability of nations to protect the environment by integrating data sets including natural resource endowments, pollution levels, and environmental management efforts into a smaller set of indicators of environmental sustainability. The United States unexpectedly ranked only 45th of countries in the index in this particular study.



10.3 LIFE-CYCLE COSTING

Life-cycle costing (LCC) assists companies to be aware of where their products are in their life cycles, because in addition to the sales effects, the life-cycle of a building may have a tremendous impact on costs and profits.

LCC is essentially a technique of combining both capital and operating costs to determine the net economic effect of an investment and to evaluate the economic performance of additional investments that may be required for green buildings. It is based on discounting future costs and benefits to dollars of a specific reference year that are referred to as Present Value (PV) dollars. This makes it feasible to intelligibly quantify costs and benefits and compare alternatives based on the same economic criterion or reference dollar. Moreover, sustainable buildings can be assessed as cost-effective through the LCC method, which is a way of assessing total building cost over time. It consists of:

- Initial costs (design and construction).
- Operating costs (energy, water/sewage, waste, recycling, and other utilities).
- Maintenance, repair, and replacement costs.
- Other environmental or social costs/benefits (impacts on transportation, solid waste, water, energy, infrastructure, worker productivity, outdoor air emissions, etc.).

Sustainable buildings are also considered healthy buildings and therefore can decrease worker illness costs. The Blueprint has several activities that aim to better incorporate LCC into the capital outlay process.

The World Business Council for Sustainable Development (WBCSD) recently came out with a study that suggests that key players in real estate and construction unfortunately often misjudge the costs and benefits of “green” buildings. Peter Morris, a principal with Davis Langdon says that “Perhaps a measure of the success of the LEED system, which was developed to provide a common basis for measurement, is the recent proliferation of alternative systems, each seeking to address some perceived imbalance or inadequacy of the LEED system, such as the amount of paperwork, the lack of weighting of credits, or the lack of focus on specific issues. Among these alternative measures are broad-based approaches, such as Green Globes, and more narrowly focused measures, such as calculations of a building’s carbon footprint or measurements of a building’s energy efficiency (the ENERGY STAR rating). All these systems are valid measures of sustainable design, but each reflects a different mix of environmental values, and each will have a different cost impact.” Also, the American Institute of Architects (AIA) recently published a Guide to Building Life Cycle Assessment in Practice which is certainly worth studying. It details the tools and tactics of balancing the costs and benefits of material and systems selection based on resource consumption and pollution from fabrication, shipping, construction, operations, and end-of-life deconstruction.

10.3.1 Initial/First Costs

Construction projects typically have initial or up-front costs which may include capital investment costs related to land acquisition, construction, or renovation and for the equipment needed to operate a facility. Land acquisition costs are normally included in the initial cost estimate if they differ among design alternatives. A typical example of this would be when comparing the cost of renovating an existing facility with new construction on purchased land.

The assumed increase in first cost is the most cited reason for not incorporating green elements into a building design strategy. Some aspects of design have little or no first cost including site orientation and window and overhang placement. Other sustainable systems that incorporate additional costs in the design phase, such as an insulated shell, can be offset, for example, by the reduced cost of a smaller mechanical system. Material costs can be reduced during the construction phase of a project by the use of dimensional planning and other material efficiency strategies. Such strategies can reduce the amount of building materials needed and cut construction costs but they require forethought on the part of designers to ensure a building that creates less construction waste solely on its dimensions and structural design. An example of dimensional planning is designing rooms of 4-foot multiples, since wallboard and plywood sheets come in 4- and 8-foot lengths. Moreover, one dimension of a room can be designed in 6- or 12-foot multiples to correspond with the length of carpet and linoleum rolls which can help reduce costs.

10.3.2 Life-Cycle Cost Analysis

This is a method for evaluating all relevant costs over time of a project, product, or measure. It takes into consideration all costs including first costs, such as capital investment costs, purchase, and installation costs; future costs, such as energy costs, operating costs, maintenance costs, capital replacement costs, financing costs; and any resale, salvage, or disposal cost, over the life-time of the project or product. LCCA is thus an engineering economic analysis (EA) tool useful for comparing the relative merit of competing project alternatives. George Paul Demos, estimating engineer at CDOT, echoes this and notes that, "The first component in an LCC equation is cost. There are two major cost categories by which projects are to be evaluated in an LCCA: initial expenses and future expenses. Initial expenses are all costs incurred prior to occupation of the facility. Future expenses are all costs incurred after occupation of the facility. Defining the exact costs of each

expense category can be somewhat difficult at the time of the LCC study. However, through the use of reasonable, consistent, and well-documented assumptions, a credible LCCA can be prepared.” According to Demos, the following are considered to be major steps that are essential to performing a proper cost analysis:

1. Establish objectives
2. Identify constraints and specify assumptions
3. Define base case and identify alternatives
4. Set analysis period
5. Define level of effort for screening alternatives
6. Analyze traffic effects
7. Estimate benefits and costs relative to base case
8. Evaluate risk
9. Compare net benefits and rank alternatives
10. Make recommendations

Sieglinde Fuller of the National Institute of Standards and Technology (NIST) says, “LCCA is especially useful when project alternatives that fulfill the same performance requirements, but differ with respect to initial costs and operating costs, have to be compared in order to select the one that maximizes net savings. For example, LCCA will help determine whether the incorporation of a high-performance HVAC or glazing system, which may increase initial cost but result in dramatically reduced operating and maintenance costs, is cost-effective or not.” But when it comes to budget allocation using LCCA is not beneficial.

While the general consensus on the valid basis for adopting a life cycle approach, nevertheless, most building stakeholders prefer to focus on minimizing direct costs or, at best, applying short time frame payback periods. Many developers, building owners, and other stakeholders hold the view that basing opinions on anything other than a reduced direct cost approach is fiscally irresponsible, when in reality the opposite is often the case. This lack of adoption is largely due to the typical corporate structure that dissociates direct and operating costs and with most constructors often lacking the mandate to reduce operating costs, although they are mandated to reduce construction cost. This unfortunate reality is also evidenced by owner/developers, who oversee construction of buildings for their own use.

The LCCA’s primary objective is to calculate the overall costs of project alternatives and to select the design that safeguards the ability of the facility to provide the lowest overall cost of ownership in line with its quality and function. The LCCA should be performed early in the design process to

allow any needed design refinements or modifications to take place before finalization to optimize the LCC. Likewise, it is important to ensure that the design complies with the new IgCCs that have come into effect. Another very important and challenging task of an LCCA (or any economic evaluation method for that matter) is to evaluate and determine the economic effects of alternative designs of buildings and building systems and to be able to quantify these effects and depict them in dollar amounts. LCCA is especially suited to the evaluation of design alternatives that satisfy a required performance level, but that may have differing investment, operating, maintenance, or repair costs; and possibly different life spans.

Although lowest LCC provides a straightforward and easy-to-interpret measure of economic evaluation, there are other commonly used methods such as Net Savings (or Net Benefits), Savings-to-Investment Ratio (or Savings Benefit-to-Cost Ratio), Internal Rate of Return, and Payback Period. Fuller sees them as being consistent with the lowest LCC measure of evaluation if they use the same parameters and length of study period. Almost identical approaches can be made to making cost-effective choices for building-related projects irrespective of whether it is called cost estimating, value engineering, or EA. And after identifying all costs by year and amount and discounting them to present value, they are added to arrive at total LCCs for each alternative. These include:

- Initial design and construction costs
- Maintenance, repair, and replacement costs
- Other environmental or social costs/benefits including but not limited to: impacts on transportation, solid waste, water, energy, infrastructure, worker productivity, and outdoor air emissions, etc.
- Operating costs that include energy, water/sewage, waste, recycling, and other utilities

Appropriate adjustments should be placed on all dollar values expended or received over time on a comparable basis as this is necessary for the valid assessment of a project's LCCs and benefits. Time adjustment is required because a dollar today will not have an equivalent value to a dollar in the future. Supplementary measures, however, are considered to be relative measures, i.e., they are computed for an alternative relative to a base case. Sieglinde Fuller says, "Supplementary measures of economic evaluation are Net Savings (NS), Savings-to-Investment Ratio (SIR), Adjusted Internal Rate of Return (AIRR), and Simple Payback (SPB) or Discounted Payback (DPB). They are sometimes needed to meet specific regulatory requirements. For example, the FEMP LCC rules (10 CFR 436A) require

the use of either the SIR or AIRR for ranking independent projects competing for limited funding. Some federal programs require a Payback Period to be computed as a screening measure in project evaluation. NS, SIR, and AIRR are consistent with the lowest LCC of an alternative if computed and applied correctly, with the same time-adjusted input values and assumptions. Payback measures, either SPB or DPB, are only consistent with LCCA if they are calculated over the entire study period, not only for the years of the payback period.”

Employing a holistic or integrated approach through active, deliberate, and full collaboration among all the players is the most likely method to achieving successful green buildings. Building-related investments typically involve a great deal of uncertainty relating to their costs and potential savings. The performing of an LCCA greatly increases the ability and likelihood of deciding on a project that can save money in the long run. Yet, this does not alleviate some of the potential uncertainty associated with the LCC results, mainly because LCCAs are typically conducted early in the design process when only estimates of costs and savings are available, rather than specific dollar amounts. This uncertainty in input values means that actual results may differ from estimated outcomes. The LCCA can be applied to any capital investment decision and is particularly relevant when high initial costs are traded for reduced future cost obligations.

A 2007 study by Davis Langdon updating an earlier study, states, “It is clear from the substantial weight of evidence in the marketplace that reasonable levels of sustainable design can be incorporated into most building types at little or no additional cost. In addition, sustainable materials and systems are becoming more affordable, sustainable design elements are becoming widely accepted in the mainstream of project design, and building owners and tenants are beginning to demand and value those features.” Likewise, Ashley Katz a communications coordinator for the USGBC says, “Costs associated with building commissioning, energy modeling and additional professional services typically turn out to be a risk mitigation strategy for owners. While these aspects might add on to the project budget, they will end up saving projects money in the long run, and are also best practices for building design and construction.”



10.4 TAX BENEFITS AND INCENTIVES

Many municipalities in the United States already offer tax credits as a means of advancing specific policy agendas. These same principles can

be applied to residences or developments that have achieved certain green building goals. Likewise, many state and local governments throughout the country are in the process of drafting new green building regulations to take advantage of incoming stimulus funding. In addition, the new Green Building Code reinforces this sustainability trend. For example, the tax benefits available to businesses through the Energy Policy Act of 2005 have now been extended. For updates visit: www.energytaxincentives.org. Also as a follow-up effort to encourage environmentally friendly construction and energy savings many states have put into place various tax incentive programs for green building. States such as New York and Oregon offer state tax credits, while others, such as Nevada, offer property- and sales-tax abatements. The federal government also offers tax credits. The state of Oregon credits vary and are based on building area and LEED certification level. At the Platinum level, for example, a 100,000 square foot building in Oregon can expect to receive a net-present-value tax credit of up to \$2 per square foot which is transferrable from public or nonprofit entities to private companies (e.g., contractors or benefactors), making it even more attractive than a credit that applies only to private owners. Also, appliance enforcement regulations were adopted on May 13, 2015 and are effective July 1, 2015.

New York State has various sales tax exemptions, property tax abatements, and personal tax credits and incentives to encourage residential installation of energy savings measures, onsite renewable generation, solar and wind renewable energy systems, and using alternative fuel for residential space heating and hot water heating. However, for onsite generation systems such as wind, solar, biomass, fuel cells to be eligible for tax incentives, they must be grid connected and net metered. The state of New York offers a tax credit for builders who meet energy goals and use environmentally preferable materials to apply for up to \$3.75 per square foot for interior work and \$7.50 per square foot for exterior work against their state tax bill. To qualify for this credit, a building needs to be certified by a licensed architect or engineer in addition to meeting specific requirements for energy use, water use, indoor air quality, waste disposal, and materials selection. This translates to mean that the energy used in new buildings must not exceed 65% of that allowed under the New York energy code and in rehabilitated buildings energy use cannot exceed 75%.

In 2005, the Nevada Legislature passed a poorly considered green building incentive package in an effort to spur private developers in the state. The legislation was hastily written in conjunction with little direction to state agencies and minimal financial analysis. The state offered a property-tax

abatment of up to 35% for up to 10 years to private development projects that achieve LEED Silver certification. This means that if the property tax represents 1% of value, it could be worth as much as 5% of the building cost, which translates to much more than the actual cost of achieving LEED Silver on a large project. This has encouraged a large number of Nevada projects to pursue LEED certification, including the \$7 billion, 17 million square feet Project City Center in Las Vegas which is one of the world's largest private development projects to date. The hastily written legislation forced the next session of the Nevada Legislature in 2007 to rethink and modify the program because it created an enormous financial crisis for the state. The state of Nevada also provides for sales-tax abatment for green materials used in LEED Silver-certified buildings. South Carolina also introduced a program of tax incentives that meet certain Green Globes or LEED standards for energy efficiency.

When appraising currently existing incentive programs, it should be noted that New York, Oregon, and Maryland preceded Nevada and utilized their state income tax code as the primary tool to further green buildings in their state. In addition, many jurisdictions have created their own unique programs. Virginia followed the Nevada model by allowing property tax abatements at a local level, New Mexico used the income tax credit approach, and Hawaii tried a new approach by requiring a green building to receive priority processing during governmental reviews for project approvals.

There are also many federal tax incentives available such as the 2005 federal Energy Policy Act which offers two major tax incentives for differing aspects of green buildings. They are: (1) Tax credit of 30% on use of both solar thermal and electric systems and (2) A tax deduction of up to \$1.80 per square foot for projects that reduce energy use for lighting, HVAC, and water-heating systems by at least 50% compared with the 2001 baseline standard. These tax deduction may be taken by the design team leader (typically the architect) when applied to government projects.

Consumers should always check the various State websites for the latest updates. Some of the more prevalent federal tax incentives include:

Consumer Incentives:

- Homeowners can compile credits for energy improvements to their homes, such as windows, insulation, and envelope and duct sealing.
- Homeowners can acquire credits for installing efficient air conditioners and heat pumps; gas or oil furnaces and furnace fans. In new or existing homes, credits can be achieved for efficient gas, oil, or electric heat pump, water heaters.

- Credits are also available for qualified solar water heating and photovoltaic systems, small wind, and geothermal heat pump systems.

Business Incentives:

- Businesses can get deductions for new or renovated buildings that Save 50% or more of projected annual energy costs for heating, cooling, and lighting compared to model national standards, and partial deductions for efficiency improvements to individual lighting, HVAC and water heating, or envelope systems.
- Investment tax credit for combined heat and power systems (CHP).
- Businesses are eligible for tax credits for qualified solar water heating and photovoltaic systems, and for certain solar lighting systems.
- Credits are available to businesses who install qualifying microturbines. These systems, which typically run on natural gas, are small power-producing systems sized to run small to medium-size commercial buildings.

Builders and Manufacturers Incentives:

- Home builders are eligible for credits for homes that exceed national model energy codes by 50%, subject to certification. Manufactured home producers are also eligible for a smaller credit for manufactured homes that exceed national model codes by 30% or that meet Energy Star standards.
- Credits are available to manufacturers of high-efficiency refrigerators, clothes washers, and dishwashers. Due to these manufacturer incentives, special consumer promotions may be available for qualifying products.

It is obvious that tax credits can provide significant savings. It reduces the amount of income tax that must be paid and unlike a deduction, which reduces the amount of income that is taxable; a tax credit directly reduces the tax itself. In the final analysis, the reader should always check online for the latest tax incentive updates as many new programs are continuously being initiated and older programs expire. For example, the Federal Solar Tax credit has been extended for 8 years and on February 17, 2009, President Obama signed into law the American Recovery and Reinvestment Act (ARRA). This Act creates new incentives for solar energy, modified existing incentives and provides billions of dollars in funding for renewable energy projects. With this Act, the United States can, in the coming years, become the largest solar market in the world. For additional details on tax incentives and credits visit: <http://energytaxincentives.org>; <http://www.dsireusa.org/incentives>; <http://seia.org>; <http://www.energy.gov/taxbreaks.htm>; <http://www.aceee.org/energy/index.htm>.

10.5 OTHER GREEN BUILDING COSTS

10.5.1 Operational Energy and Water Costs

Other green building expenses include operational expenses for energy, water, and other utilities. These depend to a large extent on consumption, current rates, and price projections. But since energy and, to a lesser extent, water consumption, building configuration, and building envelope are interdependent elements, energy and water costs are usually assessed for the building as a whole rather than for individual building systems or components. Sometimes the latest, greenest technology just is not approved yet and may cause both delays and additional costs.

Accurate forecasts or predictions of energy costs during the preliminary design phase of a project are rarely simple. Assumptions have to be made regarding use profiles, occupancy rates, and schedules, all of which can have a dramatic impact on energy consumption. There are several suitable computer programs currently on the market like Energy-10 and eQuest that can provide the required information regarding assumptions on the amount of energy consumption for a facility. Alternatively the information and data can come from the engineering analysis. Other software packages, such as ENERGY PLUS (DOE), DOE-2.1E, and BLAST are also excellent programs but which require a more detailed input not normally available until later in the design process when the design concept is more fully developed. It is also important to determine prior to program selection whether annual, monthly, or hourly energy consumption estimates are required and whether the program is capable of adequately tracking savings in energy consumption even when design changes take place or when different efficiency levels are simulated. Fig. 10.6 provides an example of the typical costs incurred by an HVAC System over its expected useful life which is 30 years.

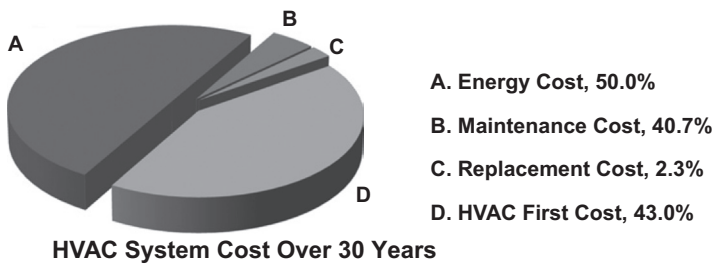

Figure 10.6 Pie Diagram illustrating typical costs (in percentage terms) incurred by an HVAC system over 30 years which represents its useful life. *Source: Washington State Department of General Administration.*

Estimates reflecting energy use in conventional and green buildings will vary, but the consensus is that green buildings on average use 30% less energy than conventional buildings, which is why energy is a substantial and widely recognized cost of building operations that can be reduced through energy efficiency and related measures that form part of green building design. A detailed survey of 60 LEED rated buildings, demonstrates that green buildings, when compared to conventional buildings reaffirms these conclusions which are:

- On average more energy efficient by approximately 25–30%
- More likely to generate renewable energy on-site
- Characterized by lower electricity peak consumption
- More likely to purchase grid power generated from renewable energy sources

Energy savings in sustainable buildings come primarily from reduced electricity purchases and secondarily from reduced peak energy demand. On average, green buildings are estimated to be 28% more efficient than conventional buildings and on average generate 2% of their power on-site from photovoltaics (PV). The financial benefits that accrue from a 30% reduced consumption at an electricity price of \$0.08/kWh comes to about \$0.30 per square foot annually with a 20-year Net Present Value (NPV) of over \$5 per square foot, equal to or more than the average additional cost associated with building green.

Jerry Yudelson, author of *The Green Building Revolution*, says that “Many green buildings are designed to use 25- to 40-percent less energy than current codes require; some buildings achieve even higher efficiency levels. Translated to an operating cost of \$1.60 to \$2.50 per square foot for electricity (the most common energy source for building), this energy savings could reduce utility operating costs by 40 cents to \$1 per square foot per year. Often, these savings are achieved for an added investment of just \$1 to \$3 per square foot. With building costs reaching \$150 to \$300 per square foot, many developers and building owners are seeing that it is a wise business decision to invest 1 to 2 percent of capital cost to secure long-term savings, particularly with a payback of less than three years. In an 80,000-sq-ft. building, the owner’s savings translates into \$32,000 to \$80,000 per year, year after year, at today’s prices.” Environmental and health costs associated with air pollution caused by nonrenewable electric power generation and on-site fossil fuel use are generally excluded when making investment decisions. [Table 10.2](#) highlights the reduced energy used in green buildings as compared with conventional buildings.

Table 10.2 Reduced energy use in green buildings as compared with conventional buildings

	Certified (%)	Silver (%)	Gold (%)	Average (%)
Energy efficiency (above standard code)	18	30	37	28
Onsite renewable energy	0	0	4	2
Green power	10	0	7	6
Total	28	30	48	36

Source: USGBC, Capital E Analysis.

10.5.2 Operation, Repair, and Maintenance Costs

Sustainability studies have shown that over the life of the building LEED-certified buildings typically both cost less and are easier to operate and maintain than conventional buildings. This puts them in a position to command higher lease rates than conventional buildings in their markets. However, maintenance and repair (OM&R) costs and nonfuel operating costs, are often more difficult to estimate than other building expenditures. Operating schedules and maintenance standards will vary from one building to the next; the variation in these costs is significant even when the buildings are of the same type and age, which is why it is important when estimating these costs to use common sense and good judgment. Published estimating guides and supplier quotes can sometimes provide relevant information on maintenance and repair costs. Some of the data estimation guides derive their cost data from databases such as Means and BOMA which typically report, for example, on average owning and operating costs per square foot, the number of square feet in the building, the number of stories, the age of the building, and its geographic location.

Typically, a green building can recoup any added costs within the first year or two of the life cycle of the building once it becomes operational. Studies show that green buildings typically use 30 to 50% less energy and 40% less water usage than its conventional counterpart, yielding significant savings in operational costs. The New Buildings Institute (NBI) recently released a new research study indicating that new buildings certified under the USGBC's LEED certification program are, on average, performing 25 to 30% better than buildings that are not LEED certified in terms of energy use. The study also suggests that buildings achieving Gold and Platinum LEED categories have average energy savings approaching 50%.

10.5.3 Durability and Replacement Costs

A durable building—one that lasts a long time—provides a long period of time to amortize the environmental and economic costs that were sustained in building it. Peter Yost, a building science expert with 3D Building Solutions, LLC, notes, “if you double the life of a building, you halve the environmental impacts [of its construction].” The same argument can be applied for the products and materials going into those buildings. Durable materials and products will not need replacement or repair as often, so the raw materials, energy, and environmental impacts invested in them can be spread out over an extended period of time. This is why the incorporation of durable materials prolongs the life of building systems and the building itself, thereby enjoying lower replacement cost of systems and materials. Replacing a building’s roof, flooring, HVAC system, or the whole building itself results in the highest cost to the environment and to the owner’s bottom line. While many of these features also reduce operating costs, an owner’s commitment to proactive maintenance is the key to keeping systems working well into their prime.

The number and timing of capital replacements of building systems are based to a large extent on the estimated life of the system and the length of the study period. It is expected that the same sources providing the cost estimates for the initial investments will be used to obtain estimates of replacement costs and expected useful lives. Likewise a good starting point for estimating future replacement costs is to use their cost as of the base date. The LCCA method is designed to escalate base-year amounts to their future time of occurrence. The term residual value of a system or component is sometimes mentioned; this basically represents the value it will have after being depreciated, i.e., its remaining value at the end of the study period, or at the time it is replaced during the study period. According to Sieglinde Fuller, residual values can be based on value in place, resale value, salvage value, or scrap value, net of any selling, conversion, or disposal costs. By using simple rule of thumb calculations, the residual value of a system with remaining useful life in place can be determined by linearly prorating its initial costs.

Elements of Durability

The durability of buildings depends on a number of specific factors that can be addressed through design and construction. These are outlined below:

- **Moisture:** To a large extent, one of the main issues of durability is water management. As an example of its significance, the publication “Durability by Design,” published by HUD’s Partnership for Advanced

Technology in Housing (PATH), devotes more than three-quarters of its space to moisture issues.

- **Heat:** Thermal stress can reduce durability by causing materials to expand and contract.
- **Sunlight:** Ultraviolet (UV) light degrades numerous materials, including many plastics, wood, fabric, and paint. Plastics that are employed outdoors, such as vinyl siding, are often treated with UV stabilizers.
- **Atmospheric Pollutants:** ozone, acid rain and the like can degrade building materials. Many synthetic materials (e.g., rubber, polyester, nylon, dyes, and certain paints) are susceptible to ozone damage.
- **Acid rain:** A product primarily from sulfur dioxide pollutants in the atmosphere.
- **Insects:** According to the National Pest Management Association, a handful of insect families are responsible for more than \$2.5 billion in damages to U.S. buildings annually. Perhaps the greatest damage is caused by termites, followed by carpenter ants and powderpost beetles, all of which can cause significant damage especially to wooden buildings.
- **Building Function:** Sometimes buildings do not function as originally intended. A building that is highly functional will be more durable and is more likely to be restored or renovated when components wear out, whereas a less functional building is more likely to be replaced. It is also important to note that the function of a building can often change over time; an inability to adapt to such changes can reduce its useful life, even if it is structurally sound.
- **Style:** Attractive, aesthetically pleasing buildings have an important bearing on durability and are more likely to be maintained and repaired as components fail than are ugly, poorly designed buildings.
- **Material Failure:** Some materials and building components have a shorter life spans than others.

10.5.4 Finance Charges and Other Costs

For federal projects finance charges and taxes do not normally apply, although finance charges and other payments do apply if a project is financed through an Energy Savings Performance Contract (ESPC) or Utility Energy Services Contract (UESC). These charges are normally included in the contract payments negotiated with the Energy Service Company (ESCO) or the utility.

Nonmonetary benefits or costs relate to project-related issues for which there is no meaningful way of assigning a dollar value, and despite efforts to develop quantitative measures of benefits, there are situations that simply

do not lend themselves to such an analysis. For example, projects may provide certain benefits such as improved quality of the working environment, preservation of cultural and historical resources, or other similar qualitative advantages. By their nature, these benefits are external to the LCCA and difficult to assess, but if these benefits are considered significant, they should be taken into account in the final investment decision and included in an LCC analysis (LCCA) and also portrayed in the project documentation. To formalize the inclusion of nonmonetary costs or benefits in the decision-making process, the analytical hierarchy process (AHP) which is one of a set of multiattribute decision analysis (MADA) methods that can be used when considering qualitative and quantitative nonmonetary attributes in addition to common economic evaluation measures when evaluating project alternatives. The ASTM E 1765 Standard Practice for Applying Analytical Hierarchy Process (AHP) to Multi-attribute Decision Analysis of Investments Related to Buildings and Building Systems that is published by ASTM International presents a general procedure for calculating and interpreting AHP scores of a project's total overall desirability when making building-related capital investment decisions. An excellent source of information for estimating productivity costs is the WBDG Productive Branch.



10.6 ECONOMIC ANALYSIS TOOLS AND METHODS

The federal government is the nation's largest owner and operator of built facilities, which during the energy crisis of the 1970s followed by the 1980s crisis, was faced with increasing initial construction costs and ongoing operational and maintenance expenses. As a result, facility planners and designers decided to use EA to evaluate alternative construction materials, assemblies, and building services with the goal of lowering costs. In today's difficult economic climate, building owners wishing to reduce expenses or increase profits are again employing EA to improve their decision making during the course of planning, designing, and constructing a building. Moreover, federal, state, and municipal entities have all enacted legislative mandates requiring the use of building EA to determine the most economically efficient or cost-effective choice among building alternatives. Fig. 10.7 is a diagram illustrating the general steps taken in an EA process.

10.6.1 Present-Value Analysis

Present-Value Analysis is based on the simple concept that the value of a dollar profit today is greater than the value of a dollar profit next year. How

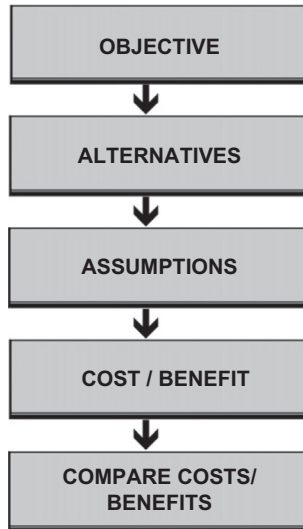

Figure 10.7 Diagram illustrating the economic analysis process. *Source: Based on Whole Building Design Guide.*

much greater is determined by what is called the “Discount Rate”, as in “how much of a discount would you expect if you were buying a dollar’s worth of next year’s profit.” The Discount Rate used in the NPV calculation is usually the Cost of Debt, also known as the Weighted Average Cost of Debt. Also NPV allows decision makers to compare various alternatives on a similar time scale by converting the various options to current dollar figures. A project is generally considered acceptable if the NPV is positive over the expected lifetime of the project. As an example, let us take a building that is considering having its lighting changed from traditional incandescent bulbs to fluorescents. The initial investment to change the lights themselves is estimated to be \$40,000. After the initial investment, it is estimated to cost \$2000 to operate the lighting system but which will yield \$15,000 in savings each year. This thus produces an annual cash flow of \$13,000 every year after the initial investment. If for the sake simplicity, a discount rate of 10% is assumed and it is calculated that the lighting system will be utilized over a 5-year time period. This scenario would produce the following Net Present-Value calculations:

$$t = 0 \text{ NPV} = (-40,000)/(1 + 0.10)^0 = -40,000.00$$

$$t = 1 \text{ NPV} = (13,000)/(1.10)^1 = 11,818.18$$

$$t = 2 \text{ NPV} = (13,000)/(1.10)^2 = 10,743.80$$

$$t = 3 \text{ NPV} = (13,000)/(1.10)^3 = 9767.09$$

$$t = 4 \text{ NPV} = (13,000)/(1.10)^4 = 8879.17$$

$$t = 5 \text{ NPV} = (13,000)/(1.10)^5 = 8071.98$$

Based on the above information, the total NPV over the lifetime of the project would come to \$9280.22.

The value of discounting is that it adjusts costs and benefits to a common point in time. Thus, to be able to add and compare cash flows that are incurred at different times during the life cycle of a building, they need to be made time-equivalent. To make cash flows time equivalent, the LCC method converts them to present values by discounting them to a common point in time, which is usually the base date. To some extent, the selection of the discount rate is dependent on the use to which it will be put. The interest rate used for discounting essentially represents the investor's minimum acceptable rate of return.

The Federal Discount Rate FY 2012 Principles and Guidelines states: "Discounting is to be used to convert future monetary values to present values. Calculate present values using the discount rate established annually for the formulation and economic evaluation of plans for water and related land resources." The discount rate for federal energy and water conservation projects is determined annually by the DOE's Federal Energy Management Program (FEMP); for other federal projects, those not primarily concerned with energy or water conservation, the discount rate is determined by the Office of Management and Budget (OMB). These discount rates, however, do not include the general rate of inflation but rather represent real discount rates. In OMB and FEMP studies, annually recurring cash flows such as operational costs are normally discounted from the end of the year in which they are incurred. In MILCON studies, they are typically discounted from the middle of the year. All single amounts such as replacement costs and residual values are discounted from their dates of occurrence.

The length of study period begins with the base date which is the date to which all cash flows are discounted. The study period includes any planning, construction, and implementation periods as well as the service or occupancy period. The study period remains unchanged for all of the considered alternatives. The service period, however, essentially begins when the completed building is occupied or when a system is taken into service. This is the period over which operational costs and benefits are evaluated. In FEMP analyses, the service period cannot exceed 25 years. The contract period in ESPC and UESC projects lies within the study period, starting when the project is formally accepted, energy savings begin to accrue, and contract payments begin to be due. The contract period generally ends with the loan being paid off.

Sieglinde Fuller maintains that, “It is particularly suitable for the evaluation of building design alternatives that satisfy a required level of building performance but may have different initial investment costs, different operating and maintenance and repair costs, and possibly different lives.” But, LCCA can be applied to any capital investment decision in which relatively higher initial costs are traded for reduced future cost obligations. Also according to Fuller, LCCA is an approach that provides a much better assessment of the long-term cost-effectiveness of a project than alternative economic methods that mainly focus on first costs or on operating related costs in the short run. Furthermore, Fuller says that LCCA can be performed at various levels of complexity, but its scope could vary from a “back-of-the envelope” study to a detailed analysis with thoroughly researched input data, supplementary measures of economic evaluation, complex uncertainty assessment, and extensive documentation.

An important attribute of LCCA is that it can be performed in either constant dollars or current dollars. Both methods of calculation produce identical present-value LCCs. However, a constant-dollar analysis does not include the general rate of inflation, which means it has the advantage of not requiring an estimate of the rate of inflation for the years in the study period. A current-dollar analysis on the other hand, does include the rate of general inflation in all dollar amounts, discount rates, and price escalation rates. Constant-dollar analysis is generally recommended for federal projects, except for projects financed by the private sector such as through the Energy Savings Performance Contracting (ESPC) and the Utility Energy Services Contract (UESC). There are several alternative financing studies available and that are usually performed in current dollars if the analyst wants to compare contract payments with actual year to year operational or energy cost savings.

10.6.2 Sensitivity Analysis

This is a technique recommended by FEMP for energy and water conservation projects. A sensitivity analysis is typically employed to investigate the robustness of a study when the study includes some form of mathematical modeling. Critical assumptions should be varied and NPV and other outcomes recomputed to determine how sensitive outcomes are to changes in the assumptions. The assumptions that deserve the greatest attention will rely on the dominant benefit and cost elements and the areas of greatest uncertainty of the program being analyzed. In general, a sensitivity analysis is used for estimates of: (1) benefits and costs; (2) the discount rate; (3) the

general inflation rate; and (4) distributional assumptions. Models used in the analysis should be well documented and, where possible, available to facilitate independent review.

10.6.3 Break-Even Analysis

For a building project, a break-even analysis is a tool used to determine when the project will be able to cover all its expenses and begin to make a profit. For a startup business, it is extremely important to determine startup costs, which provide the information needed to generate enough sales revenue to pay the ongoing expenses related to running the business. A break-even analysis therefore is a useful tool in tracking a business's cash flow. Break-even analysis focuses on the relationship between fixed cost, variable cost, and profit. It is mostly used when decision-makers want to know the maximum cost of an input that will allow the project to still break even, or conversely, what minimum benefit a project can produce and still cover the cost of the investment. To perform a break-even analysis, benefits and costs are set equal, all variables are specified, and the break-even variable is solved mathematically. Since we are dealing with cash flow, and depreciation is a noncash expense, it's subtracted from the operating expenses. The variables needed to compute a break-even sales analysis for a particular project include:

- Gross profit margin
- Operating expenses (less depreciation)
- Annual debt service (total monthly debt payments for the year)

10.6.4 Computer Estimating Programs

Computer programs can considerably reduce the time and effort spent on formulating the LCCA, performing the computations, and documenting the study. There is a large number of LCCA-related software programs available all of which can be found on the Internet. As an example, the U.S. Department of Energy (DOE) Building Technologies Website has information on more than 200 software tools. Some of the software is free and downloadable. Below are some of the more popular and widely used applications:

- Isograph's AvSim+ and RCMCost software for system availability simulation and reliability-centered maintenance. In addition, it includes Weibull Analysis and Life Cycle Costing modules.
- ECONPACK (Economic Analysis Package) for Windows is a comprehensive EA computer package incorporating EA calculations,

documentation, and reporting capabilities. It is structured to permit it being used by noneconomists to prepare complete, properly documented EA in support of DoD funding requests. The program was developed by the U.S. Army Corps of Engineers. The analytic capabilities of ECONPACK are reportedly generic, providing standardized EA methodologies and calculations to evaluate a broad range of capital investment categories such as hospitals, family housing, information systems, utility plants, maintenance facilities, commercially financed facilities, and equipment.

- The Building Life-Cycle Cost (BLCC) program analyzes capital investments in buildings. FEMP's BLCC software can help calculate life-cycle costs, net savings, savings-to-investment ratio, internal rate of return, and payback period for Federal energy and water conservation projects funded by agencies or alternatively financed. The BLCC Program, version 5.3-09 is a program and EA tool developed by the National Institute of Standards and Technology (NIST) for the U.S. Department of Energy FEMP. BLCC 5.3 conducts economic analyses by evaluating the relative cost effectiveness of alternative buildings and building-related systems or components. Typically, BLCC is used to evaluate alternative designs that have higher initial costs but lower operating-related costs over the project life than the lowest-initial-cost design. It is especially useful for evaluating the costs and benefits of energy and water conservation and renewable energy projects.
- Life-Cycle Cost in Design WinLCCID Program was originally developed for MILCON analyses by the Construction Engineering Research Laboratory of the U.S. Army Corps of Engineers. The program is a life cycle costing tool that is used to evaluate and rank design alternatives for new and existing buildings and carry out "what if" analyses based on variables such as present and future costs and/or maintenance and repair costs.
- ENERGY-10 is a cost estimating program tool that assists architects, builders, and engineers to rapidly (within 20 min) identify the most cost-effective, energy-saving measures to employ in designing a low-energy building. Using climate data that are site-specific, see how different combinations of materials, systems, and orientation yield lesser or greater results, based on energy use, comparative costs, and reduced emissions. Using the software at the early phases of a design can reportedly result in energy savings of 40% to 70%, with little or no increase in construction cost. The software is available through the Sustainable Buildings Industry Council (SBIC).

- Success Estimator Estimating and Cost Management System is a cost estimating tool available from U.S. Cost that gives Estimators, Project Managers, and Owners real-time, simultaneous access to their cost data and estimating projects from any Internet-connected computer.

10.6.5 Relevant Codes and Standards

There are many codes and standards that are relevant to green building. These include:

- IgCC—2012
- ASTM E2432—Standard Guide for the General Principles of Sustainability Relative to Building
- Circular No. A-94 Revised—Guidelines and Discount Rates for Benefit-Cost Analysis of Federal Programs
- 10 CFR 436 Subpart A—Federal Energy Management and Planning Programs, Methodology and Procedures for Life-Cycle Cost Analyses
- Energy Policy Act of 2005 (established a tax deduction for energy-efficient commercial buildings applicable to qualifying systems and buildings placed in service from January 1, 2006, through December 31, 2007. This deduction was subsequently extended several times, and is now set to expire at the end of 2016)
- Executive Order 13,123—Greening the Government through Efficient Energy Management, DOE Guidance on Life-Cycle Cost Analysis Required by Executive Order 13,123
- Executive Order 13,423—Strengthening Federal Environmental, Energy, and Transportation Management
- Facilities Standard for the Public Buildings Service, P100 (GSA)—Chapter 1.8—Life-Cycle Costing
- Standards on Building Economics, 6th ed. ASTM, 2007
- Sustainable Building Technical Manual (DOE/EPA)
- NAVFAC P-442 Economic Analysis Handbook
- Tri-Services Memorandum of Agreement (MOA) on “Criteria/Standards for Economic Analyses/Life-Cycle Costing for MILCON Design” (1991)
- ICC 700-2012: 2012 National Green Building Standard (ICC 700)



Green Project Commissioning



11.1 GENERAL OVERVIEW

The Building Commissioning industry is rapidly growing. And over the last decade, building commissioning (Cx) has grown from an incongruent group of researchers and engineers into a recognized industry of professionals that is increasingly being embraced by public and private organizations such as the American Society of Heating, Refrigerating and Air-Conditioning Engineers (ASHRAE), the Building Commissioning Association (BCA), and the National Conference on Building Commissioning (NCBC). Also, for the first time, California's building commission recently adopted the first statewide green building code which took effect on January 2011. Additionally, the First National Green Building Code has recently been approved by the International Green Construction Code (IgCC) which further underscores the importance of building commissioning. This is because building commissioning is an important quality assurance service in the building industry and offers many benefits in improved project delivery results and because building commissioning undoubtedly enhances a building's value to the owner. This is partly why more and more engineering firms currently consider commissioning services as a core business component. Recent studies clearly demonstrate that commissioning has been found to be the single-most cost-effective strategy for reducing energy, costs, and greenhouse gas emissions in buildings today, which is why it is being integrated into the construction process to ensure that owners and investors get good buildings for their investments. However, it is imperative to start the commissioning process as early as possible, preferably in the pre-design phase. Early involvement is critical for the timely and expedient development of the Owner's Project Requirements (OPRs), the ensuing design team Basis of Design (BOD), the Commissioning Plan, and the beginning of the Operations & Maintenance (O&M) Systems Manual.

Building commissioning (Cx) is one way to reduce risk for new construction projects or major capital improvements (i.e., renovations), and it is a comprehensive way to assess and tune up performance of existing

buildings. Many building owners are now demanding higher performance in their buildings from their architects, engineers, and contractors. This impetus for increased momentum for commissioning is also coming from energy and environmental policymakers as well as the private sector and is increasingly resonating with building owners' interest in greening their properties and those seeking LEED or Green Globes certification. *ASHRAE Guideline 0, The Commissioning Process*, defines commissioning as "a quality-oriented process for achieving, verifying, and documenting that the performance of facilities, systems, and assemblies meets defined objectives and criteria."

Modern buildings today are increasingly containing sophisticated conservation and environmental control technologies which, to function properly, require careful supervision of installations, testing and calibration, and adequate training of building operators. Many of these modern sustainable (and conventional) buildings may possess high-technology electrical or air-conditioning systems or employ certain sustainable features that may require specialized attention to ensure they operate as designed. Successful Project commissioning can be very helpful in reducing operating and maintenance costs, as well as extending the useful life of the equipment and help fulfill LEED certification requirements (Fig. 11.1a and b). Cx also provides better planning, coordination, and communication between the various stakeholders, resulting in fewer change orders, shorter punch lists, and fewer callbacks. In addition, Cx new construction projects can help reduce construction delays, ensure the correct equipment is properly installed, increase productivity, and provide healthier occupant conditions and thereby reduce employee absenteeism. Once the project is completed, it is important that all the as-built information and operating and maintenance information be passed on to the owners and operating staff. Research has shown that returns for these commissioning services often pay for themselves in energy savings within a year of the project being completed.

As mentioned earlier, modern building commissioning is a fairly recent concept that includes what was historically referred to as "testing, adjusting and balancing." But in today's high-technology world, commissioning goes much further; it acquires additional importance when complex mechanical and electrical systems are involved, and there is a need to ensure that these systems operate as intended, achieving energy savings and an improved building environment that justifies the incorporation and installation of such complex systems. Cx is also crucial to achieving optimum performance

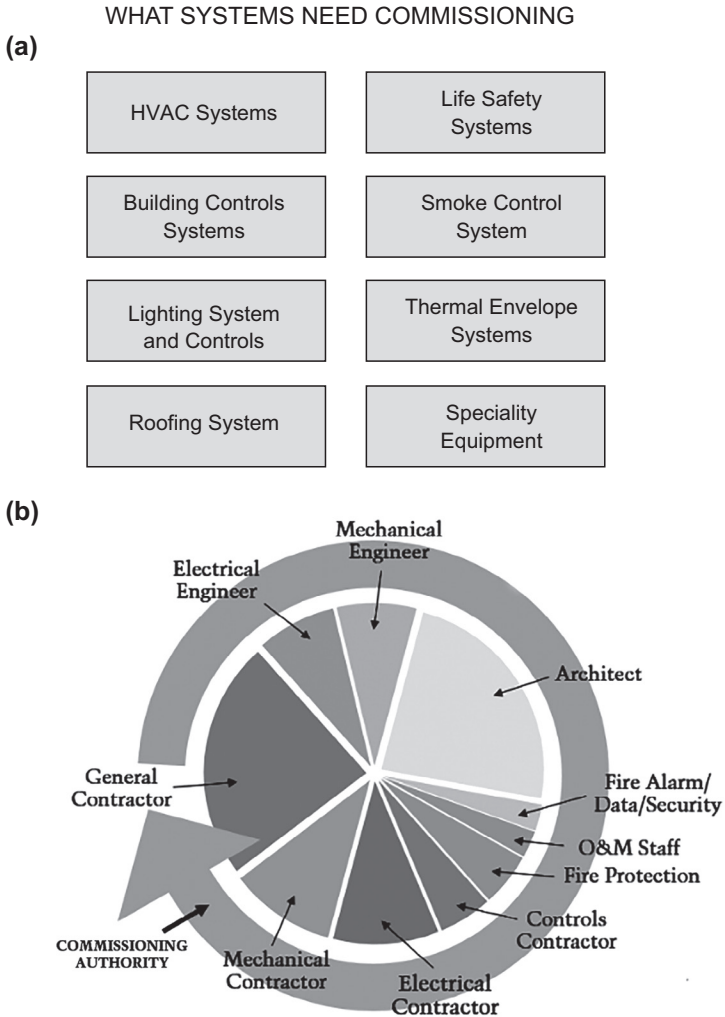

Figure 11.1 (a) Diagram depicting the general scope for building commissioning and the major systems that typically need commissioning. (b) Diagram showing the various participants in the commissioning process.

when special building features are installed to generate renewable energy, recycle waste, or reduce other environmental impacts. Furthermore, commissioning practices should be specifically tailored to address the size and complexity of the building, its systems and components to verify their performance and to confirm that all requirements are met as per the construction documents (CDs) and specifications. In addition to verification of the installation and performance of systems, commissioning will ultimately

culminate in the production of a commissioning report for the owner which could prove helpful should problems arise in the future.

The incorporation of a total building commissioning (TBCx) approach as part of the design, construction, and operation process of a new building can help eliminate any potentially frustrating failures of essential systems that do not operate according to specifications or as intended. The level of commissioning applied should be appropriate to the complexity of the project and its systems, and the owner's need for assurances, as well as the budget and time available. For example, HVAC commissioning costs will vary but are usually in the range of 1–4% of the value of the mechanical contract. It is prudent in this case to request several quotations.

A recent study entitled, “*Building Commissioning: A Golden Opportunity for Reducing Energy Costs and Greenhouse-gas Emissions*” by Evan Mills (July 21, 2009) responds to an apparent lack of confidence and understanding by end-users in the nature and level of energy savings that can be achieved through the commissioning process. The report tackles this issue head on primarily by assembling numerous case studies and previously unpublished data, in addition to incorporating performance benchmarks using standardized assumptions. Some of the key findings outlined in the report include:

- Median commissioning costs were found to be between \$0.30 and \$1.16 per square foot for existing buildings and new construction, respectively and 0.4% of total construction costs for new buildings
- Median whole-building energy savings are between 16% and 13%
- Median payback times between 1.1 and 4.2 years
- Median benefit-cost ratios between 4.5 and 1.1
- Cash-on-cash returns between 91% and 23%
- Very considerable reductions in greenhouse-gas emissions were achieved, at a negative cost of –\$110 and –\$25/ton CO₂-equivalent.
- High-tech buildings are particularly cost-effective and saved large amounts of energy and emissions due to their energy-intensiveness.
- Projects employing a comprehensive approach to commissioning attained nearly twice the overall median level of savings and five times the savings of projects with a constrained approach.
- Nonenergy benefits are extensive and often offset part or all of the commissioning cost.
- Limited multiyear postcommissioning data indicate that savings often persistent for a period of at least 5 years.
- Uniformly applying our median whole-building energy savings value to the stock of U.S. nonresidential buildings yields an energy savings

potential of \$30 billion by the year 2030 and annual greenhouse gas emissions reductions of about 340 megatons of CO₂ each year. An industry equipped to deliver these benefits would have a sales volume of \$4 billion per year and support approximately 24,000 jobs.

The commissioning of building systems is bound to vary from one project to another. Most building projects will generally involve equipment start-up, HVAC systems, electrical, plumbing, communications, security and fire management systems, and their controls and calibration. Large or complex projects may include other systems and components. Commissioning usually begins with checking the documentation and design intent for reference. Performance testing of components is conducted upon first arrival on the jobsite and again after installation is complete. The final step of commissioning is usually providing maintenance training and manuals.

Surprisingly, even though TBCx is becoming a more common process in all types of commercial construction, according to the Whole Building Design Guide (WBDG), there are currently no building code requirements at a national level that mandate Building Commissioning. But although no current U.S. model building codes require TBCx, some elements of the commissioning process are mandated by codes. Also, studies repeatedly show that proper commissioning is cost effective and benefits all new or renovation building programs. Furthermore, recent case studies conducted in private sector facilities have concluded that the Building Commissioning Process can significantly improve building energy performance by 8–30%. The application of Formal Building Commissioning Processes to complex building types with highly integrated building systems can reap dramatic benefits. Indeed, the WBDG says that some governmental agencies, such as the GSA, NAVFAC, and USACE have adopted formal requirements, standards or criteria for commissioning of their capital construction projects, but that the level of commissioning utilized will depend on a number of factors including available project funds.



11.2 FUNDAMENTAL COMMISSIONING BASICS

11.2.1 What Is Commissioning?

Building commissioning (Cx) is an all inclusive systematic quality assurance process of ensuring that building systems are designed, installed, tested, and capable of being operated and maintained to perform interactively according to the design intent and the owner's operational needs. Thus, the U.S. General Services Administration (GSA) defines commissioning as: "A systematic process of assuring by verification and documentation from the

design phase to a minimum of one year after construction that all facility systems perform interactively in accordance with the design documentation and intent, and in accordance with the owner's operational needs, including preparation of operation personnel." For new construction the process ideally begins at a project's inception (i.e., the beginning of the design process) and continues through construction, start-up, inspection, testing, balancing, acceptance, training, and an agreed warranty period (i.e., occupancy and operations). Building commissioning (Cx) therefore encompasses all the necessary planning, delivery, verification, and managing risks to critical functions performed in, or by, facilities. Cx also accomplishes higher energy efficiency, improved environmental health and occupant safety, and improved indoor air quality (IAQ) by making sure the building components are working correctly and that the plans are implemented with the greatest efficiency. It basically confirms that the systems are efficient and cost effective, and the installation is adequately documented according to requirements written into the project contract documents and that the operators are adequately trained.

As a quality assurance-based process, Commissioning is intended to deliver preventive and predictive maintenance plans, tailored operating manuals, and training procedures for users to follow. The principal function of the commissioning process therefore is to ensure that the various systems such as the HVAC&R systems and associated controls, domestic hot water systems, lighting controls, renewable energy systems (PV, wind, solar, etc.), and other energy-using building systems meet the owner's performance requirements, and perform and operate as intended and at optimal efficiency (Fig. 11.2). For example, commissioning can:

- Ensure that a new building begins its life with systems at optimal productivity and increase the likelihood that the building will maintain this level of performance throughout its useful life
- Restore an existing building to high productivity
- Ensure that building renovations and equipment upgrades function as designed



11.3 BUILDING COMMISSIONING OBJECTIVES— COSTS AND BENEFITS

11.3.1 Why Commission?

Most research clearly shows that the vast majority of building energy systems fail to function to their full potential. Irrespective of how carefully

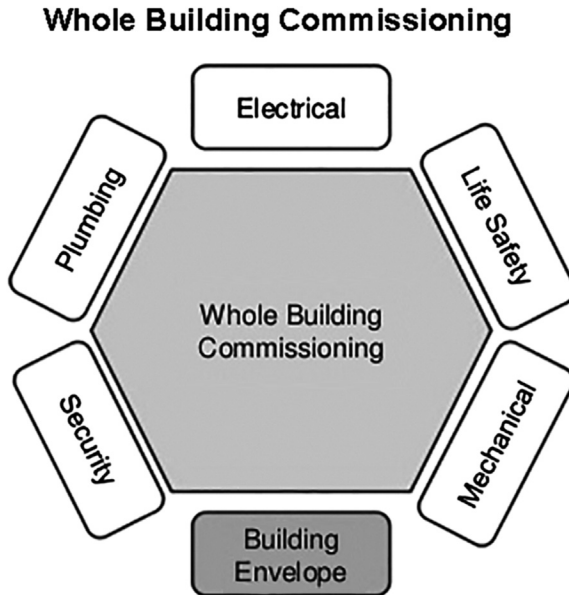

Figure 11.2 Diagram depicting the general scope for whole-building commissioning and the primary building systems that typically require commissioning.

a building is designed, if the systems, equipment, and materials are not installed and operating as intended, the building will not perform well. Poor communication of design intent, inadequate equipment capacity, inferior equipment installation, insufficient maintenance, and improper system operation all adversely impact energy cost savings. And perhaps now more than ever, effective operations require subsystems and components that work effectively and reliably and a building staff that has the knowledge and resources to operate and maintain them. This is sometimes difficult in today's competitive construction environment where building owners and project team members have become increasingly cost conscious and seldom allocate for an adequate budget to quality assurance processes. The nature of deficiencies frequently found in noncommissioned energy projects vary considerably and include:

- Various air flow problems
- Underutilized energy management systems for optimum comfort and efficient operation
- Short cycling of HVAC equipment leading to premature failures
- Inadequate documentation of project installation/operational requirements during warranty period

- Inappropriate heating and cooling sequence of operation
- Erroneous lighting and equipment schedules
- Erroneous calibration of controls and sensors
- Improperly installed or missing equipment
- Malfunctioning economizers (free cooling) systems
- Inadequate or lack of training for staff maintenance personnel
- O&M manuals not specific to installed equipment

The outcome of poorly performing buildings can cause system and equipment problems that result in higher than necessary utility bills. Furthermore, any unexpected or excessive equipment repair and replacements due to premature failures will cost the owner money. Having good indoor environmental quality will help prevent employee absenteeism, tenant complaints, and turnover. It will also minimize potential lawsuits and expensive retrofits.

11.3.2 Benefits of Fundamental Commissioning

As previously mentioned, often during the commissioning process, it is discovered that systems do not meet performance requirements due to errors in the design. Also, if a member of the design team is the designated “commissioning authority (CxA),” there is an obvious conflict of interest, because a person representing the design team may compromise the commissioning process to justify the design. This is why it is so important to employ complete commissioning of the project. According to LEED, the intent of fundamental commissioning is “To verify that the project’s energy-related systems are installed, and calibrated to perform according to the owner’s project requirements, basis of design and CDs.

Benefits of commissioning include reduced energy use, lower operating costs, fewer contractor callbacks, better building documentation, improved occupant productivity and verification that the systems perform in accordance with the owner’s project requirements.” Building commissioning offers many benefits which can be achieved no matter when the process begins, but the earlier the commissioning process takes place, the greater the potential benefits. Since all modern building systems are integrated, a deficiency in one or more components can adversely impact the operation and performance of the other components. Rectifying these deficiencies therefore can result in numerous benefits such as:

- Improved energy efficiency generally means lower utility bills (Fig. 11.3)
- Improved occupant comfort and workplace performance
- Improved functioning of systems and equipment, therefore reduction in design problems

Illustrative Relationships between commissioning and energy efficiency measures

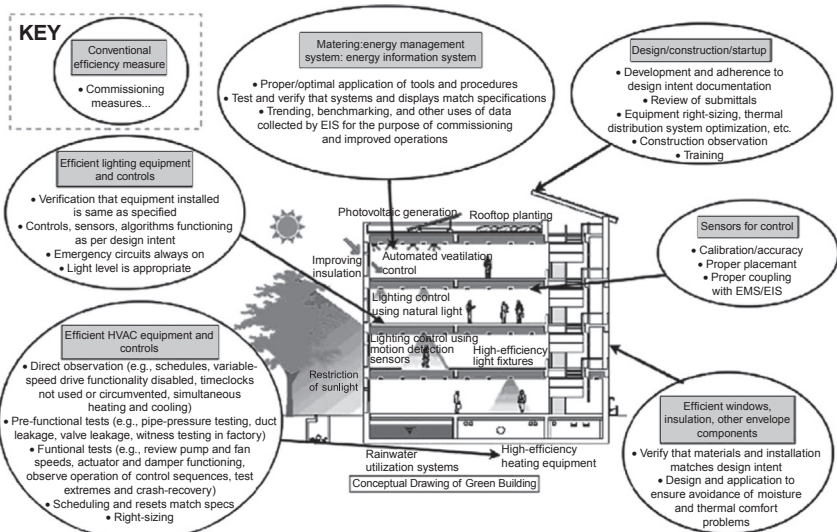

Figure 11.3 Illustration from a July 2009 report prepared for the California Energy Commission Public Interest Energy Research (PIER) showing the relationships between commissioning and energy efficiency measures. *Source: Mills, E., July 21, 2009. Building Commissioning: A Golden Opportunity for Reducing Energy Costs and Greenhouse-Gas Emissions. California Energy Commission Public Interest Energy Research (PIER) and Lawrence Berkeley National Laboratory, 1996. The Commissioning Process: In Search of a Universal Definition and Application. labs21.lbl.gov/DPM/Assets/a2_sharpleess.pdf.*

- Reduced RFIs and change orders
- Provides faster and smoother equipment start-up due to systematic equipment and control testing procedures
- Increased owner satisfaction
- Increased occupant safety
- Significant life cycle extension of equipment/systems
- Enhanced environmental/health conditions by improving quality of indoor environment
- Improved building system/equipment reliability and maintainability
- Improved building documentation
- Shortened occupancy transition period and reduced postoccupancy corrective work
- Increased value as a result of better quality construction

From the above, we see that commissioning generally facilitates the delivery of a project that provides a safe and healthy facility; optimizes energy

use; reduces operating costs; ensures adequate O&M staff orientation and training; and improves installed building systems documentation. In addition, commissioning benefits owners' through improved energy efficiency, improved workplace performance due to higher IAQ, reduced threats risks, and prevention of business losses. Some industry sources estimate that on average the operating costs of a commissioned building are between 8% and 20% below that of a noncommissioned building. Meanwhile, the cost of not commissioning is equal to the costs of correcting deficiencies plus the costs of inefficient operations. Commissioning is even more crucial for mission-critical facilities, as the significant cost of not commissioning can be measured in terms of wasted downtime and lack of required facility use which can be quite substantial.

The most significant benefit from commissioning is the results that come from better building control which extends equipment life in addition to improving operation efficiency through frequent equipment cycling avoidance, and the ensuing improvements to thermal comfort and IAQ. General building performance is also enhanced through commissioning by improving coordination between building systems. Furthermore, it provides the owner with additional in-house knowledge for optimizing equipment, system, and control efficiencies, thus helping to minimize occupant complaints, employee absenteeism, and increase staff retention. Although difficult to quantify, it is estimated that the health and productivity benefits of a building with good IAQ is likely to be worth approximately five times the energy and operating cost savings as a building with poor IAQ.

Another advantage of commissioning is that it provides better up-front performance accountability since problem prevention is invariably less expensive than problem correction. Providing front-end performance accountability and quality control allows frequent comparison of consistent project construction with project design, thus providing rapid feedback to design professionals on the dynamic performance of their design. Proper commissioning also considerably reduces the risk of liability from equipment failure or environmental hazards. In fact, corporations typically use commissioning on projects to ensure peak performance to positively impact the bottom line and business continuity, while manufacturers find the commissioning process essential due to the high levels of environmental controls required in their processes and to ensure occupational safety. Most governmental projects today also employ commissioning because mission-critical facilities support essential public infrastructures. While it is evident that projects with special performance needs in particular require

proper commissioning, in fact all projects if they are to perform satisfactorily require some level of commissioning.

There are a number of factors that are driving up the demand for commissioning of modern facilities including performance needs and the desire to obtain certification through green certification programs such as the LEED and Green Globes programs. These rating systems have been developed to improve energy efficiency and environmental performance in buildings. Fundamental Commissioning of Building Energy Systems is considered a prerequisite for LEED v4 and LEED v3 certification (although Enhanced Commissioning can achieve two possible credits) and is also a requirement in Green Globes (check the U.S. Green Building Council (USGBC) and Green Globes websites for latest updates). Buildings certified to these rating systems are likely to include highly efficient power and lighting systems, photovoltaic and active/passive solar technologies, which from an owner's perspective of such sophisticated building technologies should be accompanied by strict construction quality assurance and performance verification measurement, which the commissioning process generally provides. We also now have for the first time in the United States a national green building code. This is quite significant as the new Green Codes require extensive pre- and postoccupancy commissioning and education of building owners and maintenance employees. Moreover, to comply with the new codes, every project is required to choose an additional "elective," which pushes the envelope for the developer further.

11.3.3 The Goals and Objectives of Commissioning

A study prepared in October 2003 for a group of more than 40 California government agencies concluded that investing in green construction will pay for itself 10 times over. The study, conducted by the Capital E Group at Lawrence Berkeley National Laboratory with input from a number of state agencies, reflects the most definitive cost-benefit analysis of green building to date.

Although the commissioning process is sometimes misinterpreted to mean focusing solely on testing upon completion of the construction phase, in reality it is primarily a collaborative process for planning, delivering, and operating buildings that work as intended. The American Society of Heating, Refrigeration and Air-Conditioning Engineers (ASHRAE) defines commissioning as "...the process of ensuring that systems are designed, installed, functionally tested, and capable of being operated and maintained to perform in conformity with the design intent... Commissioning begins with

planning and includes design, construction, start-up, acceptance and training, and can be applied throughout the life of the building.” This definition accurately depicts commissioning as a holistic process that spans from pre-design planning to postconstruction operation. It consists basically of a checks-and-balances process that ensures a building’s systems perform as intended.

According to the WBDG, the main objectives of commissioning are to:

1. Define and document requirements at the commencement of each phase appropriate updates throughout the process
2. Establish and document commissioning process tasks and responsibilities for subsequent phase delivery team members
3. Verify and document compliance as each phase is completed
4. Deliver construction projects that meet the owner’s needs, at the time of completion
5. Verify that operation and maintenance personnel and occupants are properly trained
6. Maintain facility performance across its life cycle

New construction project commissioning typically goes through Pre-Design and Design phases to establish an owner’s needs, goals, scope, and design solutions for a proposed project. The evaluation of proposed designs and constructed work can only be made by comparison with objective criteria and measures that can be found in well-documented project requirements. Project development is a continuous learning process where building performance decisions undergo continuous refinement over the course of a project’s life cycle. The main commissioning activities supporting this principle include:

- Comprehending the key program goals and objectives
- Comprehending the needs of special building types
- Determining key threats, risks, and consequences
- Critical analysis of systems to facilitate achieving goals
- Conduct important commissioning programming activities

11.3.4 Factors Affecting Cost of Commissioning

Commissioning costs will vary with each project and depends on several factors such as the project’s size, complexity, and the scope of the commissioning process. For this reason, commissioning costs are difficult to accurately estimate. However according to INVIRO Design & Consulting, LLC, “The total building commissioning costs for commissioning agent services can range from 0.5% to 1.5% of total construction costs (according

to U.S. Department of Energy's Rebuild America Program, written by the Portland Energy Conservation, Inc. (PECI)). The National Association of State Facilities Administrators (NASFA) recommends budgeting 1.25 to 2.25% of the total construction costs for total building commissioning agent services. GSA's commissioning practice is expected to cost approximately 0.5% of the construction budget for federal buildings and border stations. More complex projects such as courthouses could run 0.8–1% of the construction budget and even more complex facilities such as laboratories can exceed 1%. Median commissioning costs were found to be \$0.30/ft² for existing buildings and \$1.16/ft² for new construction by the Lawrence Berkeley National Labs. iii Factors influencing commissioning costs include facility type, phasing 24/7 operations, the depth and breadth of commissioning services, the level of commissioning desired, and the systems and assemblies chosen to be commissioned (source: INVIRO Design & Consulting, LLC).” But it should be noted that there is no standard convention for determining which costs are included in the total cost of commissioning. Because it is difficult to define precisely, the cost of commissioning, it is most often presented as a range of potential costs rather than a specific dollar amount. But no matter how it is defined, the cost of commissioning generally accounts for only a very small percentage of the overall construction budget and an even smaller percentage of the building's life cycle costs.

Some of the many factors that can impact the overall cost of commissioning include:

- Size and type of building
- Number and type of systems to be commissioned and the sample rate of like systems and equipment
- Complexity of systems to be commissioned
- At what phase commissioning starts (e.g., during design, construction, or postconstruction)
- Degree to which the CxA actively performs testing (as opposed to passively observing testing)
- New construction of building renovation
- Required deliverables (design intent document, commissioning plan, commissioning specification, O&M manuals, training plans, final report, etc.)
- Commissioning process protocol (does it include documenting and witnessing all equipment prestart-up and start-up activities, prefunctional test procedures, functional test procedures, spot check tests, balance, etc.)

- To what extent will operators assist in testing (including the future building operators in testing can help reduce the time required by the CxA)
- Costs allocation (e.g., does it include commissioning consultant's fees, increased contractor bids, increased designer fees, O&M personnel time, etc.)
- What tools are available such as installed sensors, meters, trend logs, etc.

11.3.5 Long-Term Cost Implications of Commissioning

The potential for long-term cost savings from building commissioning is considerable, and which theoretically, could induce owners to perform system commissioning with payback being a major consideration. It is not surprising, however, that studies show that commissioning costs per square foot tend to be higher for more complex buildings such as hospitals, and as a result of their relatively high energy intensity, commissioning payback has also been found to be lowest in these building types. For existing buildings, the median whole-building energy cost savings associated with commissioning was found to be about 15%. Some of the potential long-range cost benefits of conducting an effective commissioning process are outlined below:

- Buildings that are properly documented are easier and less time consuming to maintain which translates into significantly lower operating and maintenance costs.
- A commissioned building is generally more energy efficient and is therefore likely to consume less energy than if the same building had not been commissioned.
- Where IAQ controls have been commissioned and are operating properly, tenants and employees have been found to be more productive, have less absenteeism, and be less likely to develop "Sick Building Syndrome" or "Building-Related Illness" symptoms.
- For specialized facilities such as industrial, research, the value of their processes, experiments, and/or collections can be far greater than the cost of commissioning or a potential product loss caused by improper control or malfunction of those systems.



11.4 PLANNING THE COMMISSIONING PROCESS

Since each building is in many ways unique, it is necessary for the commissioning process to be adapted to meet the specific needs of each individual building project. To get the full benefit of commissioning, the

commissioning plan should provide guidance in the execution of the commissioning process and preferably commence early in the design process. It is also very important to establish a clear method for sharing information at the earliest stages of the process. Likewise, it should contain a process for identifying planning delivery team member roles and responsibilities and tasks for the various project phases and activities. These include development and approval of Commissioning Plans, overview of review and acceptance procedures, documentation compliance, checking commissioning schedules, and testing and inspection plans. The process must also include identification of special testing needs for unique or innovative assemblies and measures that will ensure appropriate O&M Training. It forms part of the bid and contract documents and is binding on the Contractor; it also outlines many of the Contractor's responsibilities, procedures, and tasks throughout the Cx process and that are part of the project. The specifications will take precedence over the Commissioning Plan. Included in the Commissioning Plan should be a full description of the functional performance testing (FPT) that will be performed during the Acceptance Phase and culminating with staff training and warranty monitoring.

Normally, the commissioning process culminates with a final complete commissioning report that is prepared and submitted to the owners along with drawings and relevant equipment manuals. This report should contain all the documentation pertaining to the commissioning process, procedures and testing results, in addition to any deficiencies and records of accepted corrections of these deficiencies. System commissioning requires specialized knowledge which is why it is usually conducted by a mechanical consultant with appropriate experience and training. This person preferably hired by and responsible directly to the project's owner and is independent of the mechanical consultant firm and general contractor. Where very large or complex projects are involved, it may be necessary to designate a special commissioning coordinator to be responsible for conducting commissioning process. The architect or designer of record (DOR) is normally designated with the responsibility of overseeing completion of the commissioning process. In cases where TBCx is requested, this typically includes additional essential systems of a building such as the building's exterior wall, plumbing, acoustical and roofing systems. Having these additional systems commissioned can provide many advantages including helping to reduce moisture penetration, infiltration and noise problems, and contribute to the building's energy and resource efficiency in addition to facilitating occupant productivity.

Table 11.1 One proposed structure of the commissioning plan structure

Element	Description
Introduction	Purpose and general summary of the plan
General project information	Overview of the project, emphasizing key project information and delivery methods
Scope	Building assemblies, systems, subsystems, and equipment to be commissioned
Team contacts	Team member contact information
Plan and protocols	Communication channels to be used throughout the project
Process	Details of tasks to be accomplished during planning, design, construction, and occupancy stages, with associated roles and responsibilities
Documentation	Documents required to identify expectations, track conditions/decisions, and validate/certify performance
Schedule	Specific sequences of events and relative time frames, dates, and durations

Source: U.S. General Services Administration, 2005. Building Commissioning Guide.

One proposed structure of the Commissioning Plan is shown in [Table 11.1](#), bearing in mind that all information contained in the Commissioning Plan must be project specific.

11.4.1 Documentation—Compliance and Acceptance

As previously mentioned, commissioning serves as a general record of the owner's expectations for project performance during the project delivery process. It is a conscience team effort that documents the continuity of the project as it progresses from one project phase to the next. In the earliest phases of the project, i.e., Planning and Development, we see the establishment of planning and programming documents that begin to define an owner's requirements, goals, and standards for building performance. By appropriately documenting the entire project delivery process, a chronological perspective is put into place that outlines and clarifies the iterative process of determining the agreed-to project requirements at each phase of the development process. Commissioning documentation therefore becomes the road map for the success criteria to be met by facilities when they are put in service and verifies that designed and installed systems meet the specified standards. After the building project is occupied, commissioning documentation becomes the benchmark to ensure that the building can be maintained, retuned, or renovated to meet future needs. The OPRs

are documented from the beginning of the facility's initiation, recording compliance, acceptance, and operations throughout the facility's life cycle. These include:

- A.** The Contractor is required to deliver to the CxA one copy of the following as specified in the Cx Plan and other sections of the specifications and contract documents:
 - 1. Shop drawings and product data relating to systems or equipment to be commissioned. The CxA shall review and incorporate any comments via the designated design engineer
 - 2. Start-up checklists along with the manufacturers start-up procedures for installed equipment. CxA will review, assist, and recommend approval if appropriate
 - 3. Provide all System Test reports. CxA will review and compile prior to FPT
 - 4. Completed Equipment Start-up certification forms in addition to the manufacturer's field or factory performance and start up test documentation. CxA will review prior to FPT
 - 5. Completed Test and Balance Reports. CxA will review prior to FPT
 - 6. Equipment and other Warrantees
 - 7. Proposed Training Plans
 - 8. O&M Information per the requirements of the Cx Plan, Division 1 requirements
 - 9. Record Drawings
- B.** Record Drawings: Contractor is to maintain at the site an updated set of record or "as-built" documents reflecting actual conditions of installed systems.

The following is a checklist guide to commissioning activities and documentation provided by the U.S. Department of Energy—Energy Efficiency and Renewable Energy:

- 1. **Owner's requirements:** List and describe the owner's requirements and BOD intent with performance criteria.
- 2. **Commissioning plan:** This should be created as early in the design phase as possible including the management strategy and list of all features and systems to be commissioned.
- 3. **Bid documents:** Integrate commissioning requirements in the construction bid and contract documents. Designate the Construction Specifications Institute (CSI) Construction Specification Section 01810 in Division 1 for general commissioning requirements. Use the unassigned Sections 01811 through 01819 to address requirements

specific to individual systems. Notify the mechanical and electrical subcontractors of Division 15 and 16 commissioning requirements in Sections 15995 and 16995.

- 4. Functional performance test procedures and checklists:** Develop functional performance test procedures or performance criteria verification checklists for each of the elements identified in the commissioning plan.
- 5. Commissioning report:** Complete a final commissioning report and submitted to the Owner. The commissioning report should summarize all the tasks, findings, and documentation of the commissioning process and will address the actual performance of the building systems in reference to the design documents. The report should identify each component, equipment, system, or feature including the results of installation observation, start-up and checkout, operation sampling, FPT, and performance criteria verification. All test reports by various subcontractors, manufacturers, and controlling authorities will be incorporated into the final report.
- 6. Training:** Assemble written verification that training was conducted for appropriate personnel on all commissioned features and systems.
- 7. Operation and maintenance manuals:** Review operation and maintenance manuals for completeness including instructions for installation, maintenance, replacement, and start-up; replacement sources; parts list; special tools; performance data; and warranty details.
- 8. Recommissioning (ReCx) management manual:** Develop an indexed ReCx management manual with components such as guidelines for establishing and tracking benchmarks for whole-building energy use and equipment efficiencies; recommendations for recalibration frequency of sensors; list of all user adjustable set-points and reset schedules; and list of diagnostic tools.
- 9. Acceptance Phase:** While this is not strictly a separate phase of the building delivery process, it is during this period that the facility and its systems and equipment are inspected, tested, verified, and accepted. This includes performance testing of equipment and systems, fire system verification, final punch list development, code official inspections, obtaining certificate of occupancy, etc. Additionally, it is during this phase that most of the formal training occurs which generally includes requirements after the construction phase is

substantially complete and occupied. Architect/Engineer (A/E) and contractor now finalize the “as-built” or record documentation. The end of this phase is marked by an “Approved Functional Completion” document.

Most of this section of the WBDG is based on the Commissioning Process recommended in *ASHRAE Guideline 0-2005*. It is strongly recommended that project teams that employ the Building Commissioning Process follow the process outlined in *ASHRAE Guideline 0* or the *Total Building Commissioning Process (TBCxP)*. *Guideline 0* has been adopted by both ASHRAE and the National Institute of Building Sciences (NIBS) and does not focus upon specific systems or assemblies but adheres to a standard process that can be used to commission any building system critical to the function of a project.

The NIBS Total Building Commissioning Program is currently working with industry organizations to develop a set of 11 (to be eventually 18) commissioning guidelines for various systems and assemblies related to TBCx. The acceptance phase is of particular importance to innovative and unique buildings, such as sustainable buildings. Sometimes the acceptance phase may also include training and developing of the system manuals. The scheduling and clearness of acceptance phase tasks are very important because they provide the information on what was delivered and also provides information for the owner to facilitate successful operation and maintenance of all building components and systems that were commissioned.



11.5 COMMISSIONING AUTHORITY (COMMISSIONING SERVICE PROVIDER)

One of the first and most important decisions that a building owner needs to make is selecting the CxA, because the CxA heads up the *commissioning team*, facilitates, and is responsible for the entire *commissioning* process. In recent years, there has been considerable discussion surrounding the legal use of the term “authority” to describe professionals who conduct building commissioning who are not officially authorized through state licensure to be equal to the “Authority Having Jurisdiction” (AHJ) in a building project. This may be why the CxA is increasingly being referred to as the commissioning service provider or commissioning agent (CxA). In this regard, Federal, state, and local codes are currently being revised to include commissioning as a necessary service in building projects. To

advocate for all who practice commissioning as a profession, the Building Commissioning Authority (BCxA) Board of Directors decided to propose a change at the national level which would avoid future argument over the title. The BCxA has proposed to ASHRAE that the term, “commissioning authority” be deleted and substituted with the term “commissioning provider” in all instances where it appears in ASHRAE Standard 202-2013, Commissioning Process for Buildings and Systems (“the Standard”). This should prevent future confusion and concerns, includes all who provide commissioning services, and clarifies the position and activities of entities that provide commissioning services. The proposal has now been approved by the ASHRAE Standard 202-2013 Committee and is in preparation for public review. When approved, the current definition—“Commissioning Authority (CxA): an entity identified by the owner who leads, plans, schedules and coordinates the Commissioning Team to implement the Commissioning Process,” and all other instances of the term located throughout the Standard, will be changed to “Commissioning Provider.”

While many stakeholders have crucial roles to play in the Cx process, the key role is played by the CxA or Commissioning Provider. This consists of a team of senior specialists that will direct and oversee the commissioning process. According to LEED, “The Commissioning Authority (CxA) is typically a third party advocate for the owner, and LEED requires the CxA for the project to be independent of the design team. The CxA should focus on the process and have a strong background encompassing design, construction, operation, and quality process control.” The CxA should be retained early on in the programming phase of the project. The CxA has various roles to play in the process that include review of component and equipment submittals by contractors, review of the various systems to be commissioned, and review the contractor’s prefunctional/start-up checklists and generally providing technical and procedural oversight during the different phases of the project, as well as to conduct FPT during the construction, validate the test, adjust, and balance (TAB) effort, and lead functional acceptance testing, and warranty phases of the project. Moreover, the CxA is also required to review and provide support in the training, as-built documentation, O&M manuals, and handover of the facility to the project owner. Upon completion of the project, the warranty phase kicks in, and the CxA is expected to periodically monitor the facility during this phase to optimize it with the actual occupancy.

11.5.1 Commissioning Authority—Commissioning Provider Responsibilities

The CxA shall organize and lead the commissioning team and essentially guide the Commissioning Process for all commissioned systems. In the preconstruction phase, this will include peer review of design submittals, ensuring that the owner's expectations are adequately documented in the *Owner's Project Requirements*, produce systems manual, and reviewing all contractor submittals. For example:

A. Construction Phase

1. Organize, chair, and prepare meeting minutes for Cx meetings.
2. Review and assist in documenting all commissioning requirements to be included in the specifications. Prepare and update the Commissioning Plan as work progresses.
3. Review relevant project documentation such as shop drawings, TAB reports, product data, record drawings, O&M data, etc. for compliance and to ensure system functionality.
4. Develop, maintain, and approve all review documents, start-up checklist forms, and issues logs (e.g., design reviews, submittal reviews, construction reviews, site visit reviews, start-up reviews, functional testing reports, O&M manual to ensure it is complete and applicable, training reviews, end of warranty reviews).
5. Observe construction and attend progress meetings as required to observe progress and assist other parties, facilitate the Cx process, and help expedite completion. And although CxA is responsible for collecting and compiling all checklists, test forms, and data forms, it does not, however, direct work nor approve/accept materials, systems, or equipment.
6. Installation to be monitored and periodically inspected during first year of occupancy, and conduct any deferred testing, and serve as a resource to building staff.
7. Prepare and submit the final Commissioning Report.
8. Compile O&M information and systems overview and format the O&M manuals.
9. Witness selected tests start-ups, and equipment training.

B. Acceptance Phase

1. Verify, test, adjust, and balance by spot check all TAB reports, control component calibration, and equipment performance certifications (test 100% of key systems or test sample percentage).
2. Analyze all trend logs.

3. Test all equipment and systems to ensure correct system operation and that systems are functioning as per specifications including failure and safety modes.
 4. Review training plan and coordinate training activities between the O&M staff and the contractors/vendors, to assure the training is appropriate for the staff.
 5. Record commissioning procedures and provide Cx report with testing documentation.
 6. Verify that contractors/vendors provide proper O&M material (fan curves, pump curves, operating parameters, etc.) and not just equipment mounting information.
 7. Follow through to ensure that all commissioning issues are resolved.
- C. Warranty Phase
1. Discuss with building users to identify any problem areas that have developed after building acceptance and shall verify such deficiency corrections made by appropriate Subcontractors.
 2. Assist owner and facility staff in developing reports and documents and requests for services to resolve outstanding problems and issues with contractor and design firms.
 3. Provide follow-up training to O&M staff, especially if new staff who was assigned to the building did not previously receive vendor training.
 4. Check building performance and conduct seasonal and other deferred testing on systems as required by the Specifications.
 5. Shall make suggestions for improvements and identify areas that may come under warranty.

The commissioning process is designed to ensure and verify that the design intent meets the owner's needs and the installation meets the design intent and that the operation and use of the facility is in accordance with the owner's design intent. It should be noted, however, that the construction contractor is not responsible for delivering the design intent nor is the A/E responsible for the installation.

11.5.2 The Commissioning Team

According to the Building Commissioning Guidelines by Energy Design Resources, "Commissioning is a team process in which members of the project team each play defined roles. The commissioning team often includes the building owner or project manager, commissioning provider, design professionals, general contractor, subcontractors and manufacturer's representatives. For LEED projects, the LEED coordinator should also be a member of

the commissioning team.” Furthermore, “The team may also include facility staff, testing specialists or utility representatives. It is important to remember that the commissioning team does not manage the design and construction of the project. It merely promotes communication among team members to identify and resolve issues in a collegial and systematic fashion.”

The individuals of the Commissioning Team are through coordinated actions responsible for implementing the Commissioning Process and are led by the CxA. All traditional parties to the design and construction process are vital to the Cx process and have a role to play as part of the CxA Team (CT). The various roles will generally provide an extra focus to their efforts and in some cases delineate required assignments and rules that are normally included in the traditional process but often ignored or poorly executed. It is important for all Commissioning Team members to be involved as early as possible in the project to allow the valuable input of their knowledge and experience in the design and to allow them to become active participants in the initial checkout and acceptance of the facility.

The initial step in the commissioning process is for the commissioning team leader (the CxA) to develop a commissioning plan (preferably at the project inception phase) and then to identify and lay out the composition of the Commissioning Team. This should then be followed by a commissioning scoping meeting, in which all team members are required to attend. The function of this meeting is largely to outline the roles and responsibilities of each team member and to describe the commissioning process and schedule. It is necessary that the Commissioning Teamwork as a cohesive unit so that all of the steps in the commissioning process are completed and the facility objectives met. In general, roles and responsibilities within the Commissioning Team do not change. The facility owner/user is normally responsible for clearly communicating the facility needs and for understanding the design and functional intent. The A/E is responsible for designing a facility that accomplishes what the user requested and is in compliance with all regulations and accepted practices. Construction contractors, subcontractors, and vendors are responsible for supplying and installing the facility per the contract documents.

The size and number of members that comprise the commissioning team will vary depending on the project’s size, type, and complexity. However, in many cases the team will include:

- Project/Facility Owner
- CxA
- Project Manager

- Users
- Operating Personnel
- A/E
- Technical Experts such as Structural, Mechanical, Electrical, LEED/Sustainability, Elevator, Fire Protection, Seismic, and other specialists.
- Construction Manager Agent (CMa)
- Construction Contractor and Subcontractors

General descriptions of the commissioning team roles and responsibilities according to the USACE LEED Commissioning Plan Template based on PECI model commissioning plans are as follows:

- CxA: Coordinates the Cx process, develops and updates Cx Plan, assist, reviews, and approves incorporation of commissioning requirements in CDs. Writes or approves tests; oversees and documents performance tests; and develops the commissioning report.
- Professional Engineer: Facilitates the Cx process; Coordinates between the general contractor and the CxA; approves test plans and signs off on performance; performs construction observation; and approves O&M manuals (design-bid-build contracts).
- General Contractor: Facilitates the Cx process, ensures that Subs perform their responsibilities, and integrates Cx into the construction process and schedule.
- Subcontractors: Demonstrate proper system performance.
- DOR: Develops and updates BOD, incorporates commissioning requirements in CDs. Performs construction observation, approves O&M manuals (design-build contracts), and assists in resolving problems.
- Project Manager: Facilitates and supports the Cx process.
- Manufacturers/Vendors: The equipment manufacturers and vendors provide documentation to facilitate the commissioning work and perform contracted start-up.

11.5.3 Commissioning Authority Qualifications and Certification

Although the building industry remains at times divided on which party should be the CxA, it is strongly recommended that an independent party be the CxA, i.e., neither the contractor, A/E nor the CM. CxA should be motivated solely by the needs of the owner and the facility user and should not normally be competitors of the A/E or contractors. Individuals chosen should be highly specialized in the types of facilities and systems to be commissioned (LEED, for example, has specific requirements in this respect), and

the more complex the project, the more experience is required of the CxA. Selecting a CxA with directly relevant experience is of particular importance when dealing with projects with special or mission-critical needs such as hospitals or labs. Because of the level of technical oversight that is expected, individuals should be a Certified Commissioning Professional (CCP), licensed Professional Engineer, or have applicable experience in specialized systems/facilities being installed, in addition to extensive experience in the design, optimization, remediation, and acceptance testing of applicable systems as well as building manual preparation and training.

Today, we find that many building projects are now requiring performance certifications such as LEED, Green Globes, Energy Star, OSHA, and others. To achieve this, certification requirements have to be determined during the planning and design phases that a commissioning for certifications can be included in the OPR and Commissioning Plans. Several organizations, including the American Institute of Architects, are formulating new programs, training and contract documents to assist their members in providing building commissioning as additional services to their clients. The BCxA has also created the CCP program to raise professional standards and provide a way for certification in the building commissioning industry. To earn a CCP certification, individuals are required to complete an application form that is reviewed by the Building Commissioning Certification Board in addition to passing a 2-h written examination. Likewise, the American Society of Heating, Refrigerating, and Air-Conditioning Engineers (ASHRAE) has recently started to offer an exam for Commissioning Process Management Professionals with the intention of helping building owners and others find qualified people to lead the commissioning process.

The growing complexity of today's building designs and equipment has resulted in a greater emphasis on the building commissioning process in recent years mainly as a quality assurance measure. The cost ramifications for delayed occupancy and the early detection of design and installation faults on their own provide more than adequate economic justification for the majority of today's commissioning projects. The commissioning process can be employed using various methods that focus on building systems and assemblies and can be readily customized to suit specific project needs. However, whatever the commissioning approach and system focus decided upon, a clear articulation of performance expectations, rigorous planning and execution, and comprehensive project testing, operational training, and documentation is crucial to achieving success at the end of the day.

The many advantages of commissioning and retrocommissioning (RCx) a building should not be seen merely as a means to save energy or reduce the payback period of investments; among other things, it also helps the environment, produces healthier buildings, improves the economic performance of a building and increases productivity. Additionally, if a building is seeking a LEED certification for new construction or for an existing building, commissioning will invariably be required. For the latest updates to the changes that have been made to commissioning requirements, owners should look at the latest version of LEED (currently version 3) released by the USGBC.



11.6 THE COMMISSIONING PROCESS

In most cases, formal commissioning has now become a prerequisite as the majority of modern buildings today incorporate complex and digitally controlled HVAC systems or natural ventilation systems integrated with HVAC systems; others especially if they are “green,” incorporate renewable energy, on-site water treatment systems, occupancy sensor lighting controls, or other high-technology systems. The building commissioning process today is generally interwoven with the overall project delivery process; however, it is not usually requested for projects with minimal mechanical or electrical complexity, such as typical residential projects.

11.6.1 Commissioning Process

The following is from Section 01 91 00—General Commissioning Requirements. It is *Guidance for designers and specifiers, with suggested language to be modified and incorporated into project specifications* and provides a brief overview of the typical commissioning tasks during construction and the general order in which they occur (source: BuildingGreen, Inc. 2007):

1. Commissioning during construction begins with an initial Commissioning meeting conducted by the CxA where the commissioning process is reviewed with the commissioning team members.
2. Additional meetings will be required throughout construction, scheduled by the CxA with necessary parties attending, to plan, coordinate, schedule future activities, and resolve problems.
3. Equipment documentation is distributed by the A/E to the CxA during the normal submittal process, including detailed start-up procedures.
4. The CxA works with the Contractor in each discipline in developing start-up plans and start-up documentation formats, including providing

the Contractor with construction checklists to be completed during the installation and start-up process.

5. In general, the checkout and performance verification proceeds from simple to complex; from component level to equipment to systems and intersystem levels with construction checklists being completed before functional testing occurs.
6. The Contractors, under their own direction, will execute and document the completion of construction checklists and perform start-up and initial checkout. The CxA documents that the checklists and start-up were completed according to the approved plans. This may include the CxA witnessing start-up of selected equipment.
7. The CxA develops specific equipment and system functional performance test procedures.
8. The functional test procedures are reviewed with the A/E, CxA, and Contractors.
9. The functional testing and procedures are executed by the Contractors under the direction of, and documented by, the CxA.
10. During initial functional tests and for critical equipment, the Engineer will witness the testing.
11. Items of noncompliance in material, installation, or setup are corrected at the Contractor's expense, and the system is retested.
12. The CxA reviews the O&M documentation for completeness.
13. The project will not be considered substantially complete until the conclusion of Commissioning functional testing procedures as defined in the Commissioning Plan.
14. The CxA reviews and coordinates the training provided by the Contractors and verifies that it was completed.
15. Deferred testing is conducted as specified or required.

For USGBC LEED certification, commissioning is an integral and prerequisite component. For New Construction, Commercial Interiors, Schools and Core and Shell categories, LEED has two commissioning components: (1) Fundamental Commissioning of Building Systems which is a prerequisite, (i.e., obligatory), and (2) Enhanced Commissioning which receives a credit (two possible credits) but which is not a prerequisite.

Ideally, the commissioning process should start at the predesign stage and take place through all phases of the building project. A CxA should also be designated as early as possible in the project time line, again ideally during the predesign phase. While it is beneficial to employ a third party CxA to provide a more comprehensive design and construction review,

it is, nevertheless, acceptable for a project to appoint a qualified member of the design team as the CxA, providing there is no conflict of interest. The CxA is required to serve as an objective advocate of the owner, direct the commissioning process, and present the owner with final recommendations regarding the performance of commissioned building systems. The CxA is expected to lead the commissioning process and to introduce standards and strategies early in the design process. Additionally, the CxA should ensure the implementation of selected measures by clearly stating all requirements in the CDs. Upon completion of construction, the CxA verifies that all systems and equipment have met minimum requirements as per contract documents and are operating as designed and intended. The CxA should also provide guidance on how to operate the building at maximum efficiency.

11.6.2 Fundamental Commissioning

The LEED intent of fundamental commissioning “is to verify that the building’s energy-related systems are installed, calibrated, and perform according to the owner’s project requirements, basis of design and construction documents.” Fundamental commissioning is a prerequisite for LEED certification (unlike Enhanced Commissioning which is a credit and not a prerequisite) and is required for both new construction and major retrofits, as well as for medium or large energy management control systems that incorporate in excess of 50 control points. Moreover, commissioning is especially important when large or very complex mechanical or electrical systems are in place or where on-site renewable energy generation systems, such as solar hot water heaters or photovoltaic arrays are in place. Commissioning should also be considered when innovative water-conservation strategies, such as composting toilets or gray water irrigation systems, are installed.

If LEED certification is to be pursued, then the commissioning team will need to implement the following commissioning process activities:

- The owner or project team must designate an individual as the CxA or Commissioning Provider to lead, review, and oversee the commissioning process activities until completion. This individual should be independent of the project’s design or construction management unless the project is smaller than 50,000 square feet.
- The designated CxA should have documented CxA experience in at least two building projects. Additionally, the designated CxA should ideally meet the minimum qualifications of having an appropriate level of experience in energy systems design, installation and operation, as well

as commissioning planning and process management. LEED also recommends that a designated CxA have hands-on field experience with energy systems performance, start-up, balancing, troubleshooting, and energy systems automation control knowledge, testing, operation, and maintenance procedures.

- CxA should clearly document and review OPRs and the BOD (BOD) for the building's energy-related systems (usually by A/E). Updates to these documents shall be made during design and construction by the design team. The commissioning process does not absolve or diminish the responsibility of the Contractor to meet the Contract Documents requirements.

Design Phase commissioning for both Fundamental and Enhanced Commissioning is intended to achieve a number of specific objectives including the following:

- OPRs i.e., the design and operational intent are clearly documented and fully understood. The OPR details the functional requirements of the different building systems from the owner's perspective and which should be fully measurable and verifiable, and to include facility use, occupant comfort, and project success. Where the owner lacks sufficient experience to formally document these requirements, the CxA may facilitate the process by conducting a workshop to assist in the OPR's development.
- Verifying and ensuring that the OPR recommendations are communicated to the design team during the design process to develop a BOD document that appropriately describes the system configurations and control sequences that will be put in place to meet the OPR and avoid later modifications to the contract.
- Ensuring that the commissioning process for the construction phase is appropriately reflected in the CDs. The CxA will conduct design reviews in the context of the BOD and preferably be able to perform an initial review prior to 50% CDs. The CxA is also required to develop specifications for the architect to incorporate into the CDs. All tasks to be performed during commissioning are described in a commissioning plan developed by the CxA.

Prior to the design process being completed, the CxA will develop a construction phase commissioning plan and shall report results, findings, and recommendations directly to the Owner. However, the owner and design team shall be responsible for updates to their respective documents. Construction phase commissioning for both Fundamental and Enhanced

Commissioning is intended to achieve a number of objectives in line with the Contract Documents, including:

- Commissioning requirements and OPR should, from the outset, be incorporated into the CDs. During and immediately prior to the construction phase, a CxA may review contractor submittals related to the systems that will be commissioned.
- The development and implementation of a proper commissioning plan. The CxA typically develops protocols for FPT during this phase based on project specifics and the sequence of operations developed by the controls engineer and the CDs. The promotion of teamwork and accountability should be strongly encouraged.
- Instigate kickoff meeting with contractors and other stakeholders.
- Verification and documentation to be provided showing that the installation and performance of energy-consuming equipment and systems meet the OPR and BOD. Upon completing equipment start-up, the CxA conducts periodic prefunctional checks of installation progress to make sure contractor mounting of systems will allow easy and safe O&M access to ensure proper maintenance over the life of the building.
- Verification and documentation to be provided that all equipment and systems in place are installed according to the manufacturer's recommendations and to industry-accepted minimum standards. Once equipment is fully installed, the CxA will conduct FPT to evaluate performance at all sequences of operation. As some functional testing can only be conducted in certain seasons, the commissioning process will usually extend beyond the completion of construction.
- A final summary commissioning report should be completed. The report shall, among other items, include an executive summary, list of participants and roles, brief building description, outline of commissioning and testing scope, and an overall description of testing and verification methods used during the commissioning.
- Verify that O&M documentation left on site is complete. Moreover, upon completing the commissioning process, the CxA's final report may include the preparation of an operations and maintenance (O&M) manual for the project.
- Verify that training of the Owner's operating personnel is adequate to operate and maintain all equipment and systems and to maintain a master Cx "issue log" through-out construction.

For existing buildings, continuous maintenance is very important especially since building systems over the years tend to become less efficient, mostly due to changing occupant needs, building renovations, and obsolete

systems. These in turn end up causing occupant discomfort and complaints. Unless these problems are appropriately addressed such as investing in a commissioning process, a facility's operating costs will dramatically increase, making it less attractive to new and existing tenants. It will be found that commissioning can typically pay for itself in less than a year (Fig. 11.4). The following checked systems are to be commissioned.

- | | |
|---|---|
| <p>HVAC Equipment and System</p> <ul style="list-style-type: none"> <input type="checkbox"/> Variable Speed Drives <input type="checkbox"/> Hydronic Piping Systems <input type="checkbox"/> HVAC Pumps <input type="checkbox"/> Boilers <input type="checkbox"/> Chemical Treatment Systems <input type="checkbox"/> Air Cooled Condensing Units <input type="checkbox"/> Makeup Air Systems <input type="checkbox"/> Air-Handling Units <input type="checkbox"/> Underfloor Air Distribution <input type="checkbox"/> Centrifugal Fans <input type="checkbox"/> Ductwork <input type="checkbox"/> Fire/Smoke Dampers <input type="checkbox"/> Automatic Temperature Controls <input type="checkbox"/> Laboratory Fume Hoods <input type="checkbox"/> Testing, Adjusting, and Balancing <input type="checkbox"/> Building/Space Pressurization <input type="checkbox"/> Ceiling Radiant Heating <input type="checkbox"/> Underfloor Radiant Heating <p>Electrical Equipment and System</p> <ul style="list-style-type: none"> <input type="checkbox"/> Power Distribution Systems | <ul style="list-style-type: none"> <input type="checkbox"/> Lighting Control Systems <input type="checkbox"/> Lighting Control Programs <input type="checkbox"/> Engine Generators <input type="checkbox"/> Transfer Switches <input type="checkbox"/> Switchboard <input type="checkbox"/> Panelboards <input type="checkbox"/> Grounding <input type="checkbox"/> Fire Alarm and Interface Items with HVAC <input type="checkbox"/> Renewable Energy Systems <input type="checkbox"/> Security System <p>Plumbing System</p> <ul style="list-style-type: none"> <input type="checkbox"/> Domestic Water Heater <input type="checkbox"/> Air Compressor and Dryer <input type="checkbox"/> Stormwater Oil/Grit Separators <p>Building Envelope</p> <ul style="list-style-type: none"> <input type="checkbox"/> Building Insulation Installation <input type="checkbox"/> Building Roof Installation Methods <input type="checkbox"/> Door and Window Installation Methods <input type="checkbox"/> Water Infiltration/Shell Drainage Plan |
|---|---|

Figure 11.4 Detailed checklist of systems to be commissioned upon completion of the project. Although commissioning needs may differ from project to project, commissioning the building envelope systems, power distribution, domestic water heating, ductwork, and any hydronic piping systems is strongly recommended for any project. *Source: based on BuildingGreen, Inc.—Section 01 91 00—General Commissioning Requirements.*

11.6.3 Enhanced Commissioning

For a LEED credit (2 points), enhanced commissioning is required in addition to the Fundamental Commissioning prerequisite. The intent of enhanced commissioning according to LEED is “To begin the commissioning process early in the design process and execute additional activities after systems performance verification is completed.” For the Commercial Interiors category, for example, the intent is to verify and ensure that the tenant space is designed, constructed, and calibrated to operate as intended. This requires the implementation, or to have a contract in place requiring implementation, further commissioning process activities in addition to the Fundamental Commissioning prerequisite requirements as stated in the relevant LEED Reference Guide (e.g., the Green Building Design and Construction, 2009 Edition).

LEED states that the duties of the CxA should include:

1. Prior to the end of design development and commencement of the CDs phase, a CxA independent of the firms represented on the design and construction team, must be designated to lead, review, and oversee the completion of all commissioning process activities. Although it is preferable that the CxA be contracted by the Owner, for enhanced commissioning, the CxA may also be contracted through design firms or construction management firms not holding construction contracts. This person can be an employee or consultant of the owner, although this requirement has no deviation for project size. Furthermore to meet LEED requirements, this person must:
 - a. have documented CxA experience in at least two building projects
 - b. be independent of the project’s design and construction management
 - c. not be an employee of the design firm, though the individual may be contracted through them
 - d. not be an employee of, or contracted through, a contractor or construction manager of the construction project
2. The CxA must report all results, findings, and recommendations directly to the owner.
3. The CxA must conduct a minimum of one commissioning design review of the OPRs, BOD, and design documents prior to the mid-CDs phase, and back-check the review comments in the subsequent design submission.
4. The CxA must review contractor submittals and confirm that they comply with the OPRs and BOD for systems being commissioned. This review must be conducted in parallel with the review of the architect or engineer of record and submitted to the design team and the owner.

5. The CxA or other members of the project team are required to develop a systems manual that provides future operating staff with the necessary information to understand and optimally operate the commissioned systems. For Commercial Interiors the manual must contain the information required for recommissioning the tenant space energy-related systems.
6. The task of verifying that the requirements for training operating personnel and building occupants have been completed may be performed by either the CxA or other members of the project team.
7. The CxA must be involved in reviewing the operation of the building with operations and maintenance (O&M) staff and occupants and having a plan in place for resolving outstanding commissioning-related issues within 10 months after substantial completion. For Commercial Interiors, there must also be a contract in place to review tenant space operation for O&M staff and occupants.

11.6.4 Retrocommissioning—Commissioning for Existing Buildings

Although building commissioning has become a critically important aspect of new construction projects and is used primarily to ensure that all installed systems perform as intended, the reality is that most existing buildings have never encountered the commissioning or quality assurance process and not unexpectedly have been found to be performing well below their intended design potential. Retrocommissioning can address problems that occurred during design or construction or address problems that may have developed throughout the building's life. The Lawrence Berkeley National Laboratory (LBNL) conducted a recent study of 60 different types of buildings which confirms this inefficiency and shows that:

- Over 50% had control problems
- 40% had HVAC equipment problems
- 15% had missing equipment
- 25% had BAS with economizers, variable frequency drives (VFDs), and advanced applications that were simply not operating correctly.

Source: Assoc. of State Energy Research Technology Internships and US Department of Energy.

The term retrocommissioning (RCx) simply refers to the commissioning of existing buildings that have not been previously commissioned and usually focuses on energy—using equipment such as mechanical equipment, lighting, and related controls with the objective being to reduce

energy waste, obtaining energy cost savings for the owner, and identifying and fixing existing problems, using diagnostic testing and O&M tune-up activities. The Building Commissioning Association (BCA) defines RCx or Commissioning for Existing Buildings as “a systematic process for investigating, analyzing, and optimizing the performance of building systems by improving their operation and maintenance to ensure their continued performance over time. This process helps make the building systems perform interactively to meet the owner’s current facility requirements.” It is important to first determine how the installed systems are designed to operate; measure and monitor their operation, and then prepare a prioritized list of the operating opportunities of the various systems.

The RCx process basically reviews the functionality of equipment and systems installed and optimizes how they work together to facilitate the reduction of energy waste, increase comfort, and improve building operation. RCx may also be required to address issues such as modifications made to system components, function/space changes from original design intent, building systems fail to operate according to designed benchmarks, complaints regarding IAQ, temperature, building-related illness (BRI), sick building syndrome (SBS), etc. [Fig. 11.5](#) is a photo of CEE hospital which is a nine-story building that the owner decided to recommission (ReCx). The Center for Energy and Environment says that, “Opportunities for recommissioning measures were identified through field measurements carried out by highly skilled and experienced engineers to quickly zero in on sub-optimal central-system operating strategies that waste energy. Major recommissioning opportunities identified included:

1. Calibration of control system instrumentation;
2. Resetting supply air temperature set point;
3. Resetting duct static pressure set point;
4. Replacing bad inlet guide vanes with VFDs;
5. Calibration of variable air volume terminal boxes;
6. Improving economizer operation;
7. Optimizing the chiller and chilled water pump operation;
8. Performing hot water and chilled water balance;
9. Optimizing heating water temperature reset schedule and on/off sequence;
10. Reducing outside air flow;
11. Calibration of thermostats;
12. Performing air balance;
13. Determining the minimum outside air damper position; and



Figure 11.5 Photo of the Cee hospital, a nine-story, 600,000 square feet acute care facility in Minneapolis, MN which recently underwent recommissioning (ReCx). The first floor was built in 1981, and the rest of the floors were added in 1982. The owner's objective in recommissioning the building was to reduce operating costs while maintaining or improving IAQ and comfort. For this project, CEE partnered with the Energy Systems Lab at Texas A&M University, which is considered to be the most experienced and effective healthcare recommissioning provider in the US. *Source: Center for Energy and Environment.*

14. Repairing kinked flex ducts and leaky reheat control valves.”

ReCx is a systematic process used to diagnose, identify, and correct performance problems in existing buildings that might otherwise prevent key central-system measures from being fully implemented and to ensure that they continue to operate optimally for the life of the facility.

The key goals of a ReCx program typically include:

- Optimization of energy consumption
- Often reduces energy use
- Identifying chronic maintenance problems
- Improve building comfort, IAQ, lighting, etc.

Operating improvements made should all be recorded and the building operator trained on how to sustain efficient operation as well as implement capital improvements. ReCx continues to witness increasing prominence as a cost-effective strategy for improving energy performance and helping to make the building's systems perform interactively in a manner that addresses the owner's current and anticipated facility requirements.

ReCx applies mainly to buildings that have previously been commissioned or retrocommissioned and where the original commissioning process documentation shows that the building systems performed as intended at one point in time. The intent of ReCx therefore is to help ensure that the benefits

of the initial commissioning or retro-Cx process remain valid. The need for ReCx depends on several factors such as changes in the function and use of the facility, quality and schedule of preventive maintenance activities, and the frequency of operational problems within the facility. In some cases, ongoing commissioning (ongoing Cx) may be necessary as an “ongoing process” to resolve operating problems, improve comfort, optimize energy use, and identify energy and operational retrofits for existing buildings. Periodic ReCx may also occur when a building that has previously been commissioned undergoes another commissioning process to help keep it operating optimally.

11.6.5 Warranty Phase

Upon completion and turnover, the building goes into the hands of the owner and operators. But although the project may be considered to be complete, some commissioning tasks from the initial commissioning contract continue throughout the typical 1-year warranty period.

Systems Performance Monitoring

This includes early occupancy of the building and continuing through the Warranty Phase, in which the CxA, representatives of the owner, and A/E team and the Contractor’s team shall verify ongoing system performance to ensure they are in line with the specifications. This is achieved by repeating selected Systems Functional Performance Tests and by reviewing energy bills and other performance-related documentation. The CxA shall then prepare a report to the owner stipulating any issues with ongoing system performance and/or confirming that the systems are functioning as designed and intended. Contractor will then update and finalize record documentation to reflect actual conditions at the end of the warranty period, and final modifications to the O&M manuals and as-builts due to the testing are made.

Moreover, according to the U.S. GSA’s *Building Commissioning Guide*, the CxA is responsible for delivering a Final Commissioning Report during the postconstruction period and which according to the GSA shall include at a minimum:

- A statement that systems have been completed in accordance with the contract documents and that the systems are performing in accordance with the final OPRs document
- Identification and discussion of any substitutions, compromises, or variances between the final design intent, contract documents, and as-built conditions
- Description of components and systems that exceed OPRs and those which do not meet the requirements and why

- Summary of all issues resolved and unresolved and any recommendations for resolution
- Postconstruction activities and results including deferred and seasonal testing results, test data reports and additional training documentation
- Lessons learned for future commissioning project efforts
- Recommendations for changes to GSA standard test protocols and/or facility design standards (i.e., GSA P-100, etc.)

The importance of the Final Commissioning Report is that it will serve as a pivotal reference and benchmark document for any future ReCx of the facility.

Deferred Seasonal Testing

Deferred or seasonal testing should be performed during the occupancy phase. Sometimes testing is delayed due to site or equipment conditions or inclement weather but will be completed during warranty period. Likewise, functional testing is performed on systems that could not be tested during the Acceptance Phase of the project because of seasonal load issues that prevent reasonable testing of a system or due to integrated systems whose operation is dependent on seasonal building loads. Systems FPT will be implemented into the opposite season from which it was initially tested to confirm successful operation of the integrated systems under building loads. These tests may also be necessary to demonstrate the performance of the occupied building where insufficient internal loads in the building prevented the CxA from adequately challenging the systems during initial testing. The requirements for deferred and seasonal testing need to be clearly defined in the contract documents to avoid confusion as the CxA and some contractor personnel will be required to return to the site after the project is completed, more specifically a few months prior to the expiration of the contractor's 1-year warranty to confirm that all systems within the facility are operating as planned and also to interview facility staff and assist the facility staff in addressing any outstanding performance problems or warranty issues, particularly before the warranty period expires. Many project owners keep their CxA on board up to a year of postoccupancy. It is also advisable to put aside money for the execution of this activity in addition to the traditionally withheld warranty items.

Postoccupancy Testing

When performing testing during the postoccupancy phase, the CxS or his representative must take care not to void any equipment warranties. The building owner should require that the contractor and subcontractors

provide the commissioning provider with a full set of warranty conditions for each set of equipment to be commissioned. This is because some warranty provisions require that the installing contractor performs the testing, under the supervision of the commissioning provider. This is why a full warranty review should be conducted.

In all cases, to meet warranty requirements, the CxA should always:

- Revisit the site after the operators have become acquainted with the systems and have generated additional questions about system operations that were not fully understood at training time.
- Provide follow-up training to O&M staff, especially if there is new staff assigned to the building that has not receive vendor training.
- Speak to building users to identify any problem areas that may have developed after building acceptance, and review equipment malfunctions or system operational issues to determine if corrective work under warranty coverage should be requested, and if so, by which subcontractor or supplier.
- Provide assistance to maintenance personnel in documenting occupant complaints to accurately determine if real equipment or system problems are the cause.
- Perform appropriate seasonal testing on systems and check building performance.
- Provide owner with adequate support to enable resolution of issues with contractor and design firms.
- Conduct 11th month walk-through to seek out any system problems prior to expiration of warranty.

Today we find that the high-performance building movement of recent years, in addition to the various energy rating prerequisites has brought building commissioning well into the mainstream. Moreover, with the increasing complexity of mechanical systems and the continuous development of new technologies, the process of TBCx has taken on an increasingly important role of building commissioning. As mentioned earlier, Cx entails more than commissioning typical systems such as HVAC; it also includes other elements such as lighting systems and controls, as well as building envelope and fenestration to ensure a building's optimum performance. It is also advisable for owners to consider recommissioning their facilities periodically to ensure that equipment performance levels are maintained as originally intended.

We also find that during these challenges times, particularly following the 9/11 terrorist attacks, designers and owners have displayed a greater

focus and urgency on providing occupant safety to visitors and workers in public facilities; this in turn has created a need to deliver and commission facilities with enhanced building safety measures. This trend for increased security has become a global issue and is likely to increase the standard of care required in the design and operation of all forms of new construction and also existing buildings.

Relevant Resources, Codes, and Standards

- *ACG—Associated Air Balance Council Commissioning Group—AABC National Headquarters*, Phone: (202) 737-0202
- *AIA B211—2007 Standard Form of Architect’s Services: Commissioning—Fixed scope of services requires architect to develop a commissioning plan, a design intent document, and commissioning specifications, based on owner’s identification of systems to be commissioned*
- *ASHRAE Guideline 0-2005: The Commissioning Process—the industry-accepted model Commissioning Guide*
- *ASHRAE Guideline 1.1, HVAC&R Technical Requirements for the Commissioning Process—2008*
- *Federal Energy Management Program—Offers programs and resources for energy efficiency in operation of federal facilities*
- *The International Green Construction Code (IgCC) March 2012*
- *The California Building Standards Commission—2010 (“CalGreen”)*
- *NIBS Guideline 3-2006: Exterior Enclosure Technical Requirements for the Commissioning Process*, National Institute of Building Sciences, 2006
- *The Building Commissioning Guide*, U.S. General Services Administration, 2005.
- *BCA. Building Commissioning Association. www.bcxa.org/resources/*
- *Model Commissioning Plan and Guide Specifications, Version 2.05*, PECCI. February 1998—Available from PECCI, 921 SW Washington, Suite 312, Portland, Oregon 97205; E-mail peci@peci.org
- *No Operator Left Behind: Effective Methods of Training Building Operators. Proceedings of the 2007 National Conference on Building Commissioning www.peci.org/nbc/proceedings/2007/Brooks_NCBC2007.pdf*
- *LEED Commissioning for New and Existing Buildings*, HPAC Engineering (online). Wilkinson, Ronald. 2008. http://hpac.com/mag/leed_commissioning_new/
- *Continuous Commissioning Guidebook for Federal Managers*, Department of Energy (DOE), October 2002
- *Commissioning Specialists Association (UK)*



Project Cost Analysis



12.1 GENERAL OVERVIEW

The construction industry has substantial environmental, social, and economic impacts on society. Because of this, society is witnessing an unusually rapid growth of the green building sector—mainly to mitigate the negative impacts associated with construction-related activities. To assist in this effort, successful development projects are grounded in painstaking analysis and rigorous planning to help formulate a comprehensive compilation of construction-related cost information as this is a pivotal tool for assessing the merits of a proposed construction undertaking. There are many software packages on the market like “Projectmates,” which has capabilities ranging from document management and scheduling to financial budgeting and change order management. Projectmates software contains over 40 different modules for almost every type of construction project and can save considerable time as well as increase accountability among the various project participants. Also, while owners may choose to delegate responsibilities to other professionals on the project team, such decisions are left to their discretion and control. It should be noted that *Projectmates* has dramatically improved the construction programs for countless organizations with vastly different backgrounds and needs.

Viewpoint Construction Software is another software package of many on the market that is dedicated to providing advanced, easy-to-use, and efficient management software and which is said to be available exclusively to the construction industry. Project Managers and estimators are indeed fortunate that there is such a wide range of computer-aided cost estimation software systems available, ranging in sophistication from simple spreadsheet calculation software to integrated systems involving design and price negotiation over the Internet. While such software involves costs for purchase, maintenance, training, and computer hardware, the user will experience significant benefits. In particular, cost estimates may be prepared more rapidly and with less effort. Professor Chris Hendrickson, Codirector of the Green

Design Institute, depicts some of the more common features of computer-aided cost estimation software such as:

- Databases for unit cost items such as worker wage rates, equipment rental, or material prices. These databases can be used for any cost estimate required. If these rates change, cost estimates can be rapidly recomputed after the databases are updated.
- Databases of expected productivity for different components types, equipment and construction processes.
- Import utilities from computer-aided design software for automatic quantity takeoff of components. Alternatively, special user interfaces may exist to enter geometric descriptions of components to allow automatic quantity takeoff.
- Export utilities to send estimates to cost control and scheduling software. This is very helpful to begin the management of costs during construction.
- Version control to allow simulation of different construction processes or design changes for the purpose of tracking changes in expected costs.
- Provisions for manual review, override, and editing of any cost element resulting from the cost estimation system.
- Flexible reporting formats, including provisions for electronic reporting rather than simply printing cost estimates on paper.
- Archives of past projects to allow rapid cost estimate updating or modification for similar designs.

The construction industry continues to have procurement problems arising from an impractical division between the design and construction process, a lack of organization among subcontractors, strained relationships between design professionals and construction team members within the integrated project team, outdated design and construction techniques, preventable delays, and inferior quality end product. However, in recent years the construction industry has demonstrated significant improvements in application of new technology and methods in which clients have been the driving force for change leading to the development of improved and more sophisticated services (e.g., project management, facilities management, better handle on cash flow, and alternate procurement methods). This need for change originated from the desire for a more competitive and efficient industry. Education programs have also been created to merge construction and design to emphasize multiskilled trades.

When it comes to green building a Davis Langdon study, "Costing Green: A Comprehensive Cost Database and Budgeting Methodology" compared the square-foot construction costs of 61 buildings pursuing Leadership in

Energy and Environmental Design (LEED) certification to those of similar conventional buildings without green objectives. Taking into consideration climate, location, and other variables, the study came to the conclusion that for many of the sustainable projects, aiming for LEED certification, resulted in little or no impact on the general budget.

Another point worth noting is that construction lending is basically real estate lending and the construction lender should therefore be aware that the primary security of the loan is primarily the real estate to be developed and that in order for the loan to be repaid the development has to be completed. Experience shows that few real estate borrowers are able to repay a construction loan from the assets listed in their financial statements. The borrower's professional and financial capabilities are key elements in the loan determination and should be thoroughly looked into before a loan commitment is made.

Professor Hendrickson says, "The costs of a constructed facility to the owner include both the initial capital cost and the subsequent operation and maintenance costs. Each of these major cost categories consists of a number of cost components."

To be able to determine the capital cost for a construction project, it is necessary to estimate the expenses related to the initial erection of the facility which according to Hendrickson include:

- Land acquisition, including assembly, holding, and improvement
- Planning and feasibility studies
- Architectural and engineering design
- Construction, including materials, equipment, and labor
- Field supervision of construction
- Construction financing
- Insurance and taxes during construction
- Owner's general office overhead
- Equipment and furnishings not included in construction
- Inspection and testing.

In addition, the project owner must also consider the operation and maintenance cost of the project over its life cycle for which Hendrickson includes the following expenses:

- Land rent, if applicable
- Operating staff
- Labor and material for maintenance and repairs
- Periodic renovations
- Insurance and taxes
- Financing costs

- Utilities
- Owner's other expenses.

The consequence and significance of each of the above cost elements rely on the project's type, size, and location as well as the management organization, among many other considerations. As far as the owner is concerned, the ultimate objective is achieving the lowest possible overall project cost that at the same time meets the specified quality and investment objectives of the project.

A well-defined Project Budget includes all the possible hard and related construction costs and identifies where the funds are coming from. To estimate the total project cost (TPC) therefore one must include all *hard* and *soft* costs to make the building complete and useable as intended. Costs would include construction costs, construction contingency, architect/engineer fee, project contingency, owner services, and administrative fees. Depending on the general conditions and contract documents requirements, the TPC may also include infrastructure costs, furniture and equipment costs, voice/data costs, instructional technology costs, moving costs, and custodial equipment costs.

Construction cost, on the other hand, is the fee charged by a general contractor or construction firm for a project. Construction costs per gross square foot will vary from state to state, whether the project is new construction or renovation and the type, size, and complexity of the project (e.g., office, educational, hospital, hotel, school, residential, etc.).

According to Hendrickson the important thing is for "design professionals and construction managers to realize that while the construction cost may be the single largest component of the capital cost, other cost components are not insignificant. For example, land acquisition costs are a major expenditure for building construction in high-density urban areas, and construction financing costs can reach the same order of magnitude as the construction cost in large projects such as the construction of nuclear power plants.

From the owner's perspective, it is equally important to estimate the corresponding operation and maintenance cost of each alternative for a proposed facility to analyze the life cycle costs. The large expenditures needed for facility maintenance, especially for publicly owned infrastructure, are reminders of the neglect in the past to consider fully the implications of operation and maintenance cost in the design stage."

Most construction budgets contain a contingency clause for unexpected cost overruns that may occur during construction. While this contingency amount may be included within each cost item, it is preferably included as a single category namely a construction contingency, which is normally a percentage of the project's estimated cost. This contingency amount is based on

COST BREAKDOWN

ITEMS	DESCRIPTION	BUDGET AMOUNT	COSTS PAID	COSTS TO BE PAID
0100	GENERAL CONDITIONS			
0101	Architecture and Design			
0102	Permits and Fees			
0104	Testing and Special Inspections			
0105	Soil Engineering			
0106	Structural Engineering			
0107	Survey and Topography			
0108	Tile 24 Compliance			
0109	Insurance and Bonds			
0110	Temporary Fencing and Security			
0111	Supervision			
0115	Temporary Sanitation			
0150	Temporary Utilities			
0199	Contingency (10% of hard costs)			
0200	SITE WORK			
0210	Clearing and Grubbing			
0211	Demolition			
0221	Site Grading			
0222	Excavation and Backfill			
0224	Erosion Control			
0255	Permanent Utilities			
0260	Paving			
0262	Curb and Gutters			
0263	Walks			
0271	Fences and Gates			
0280	Sewer Connections—Septic Tank			
0300	CONCRETE			
0310	Formwork			
0320	Steel Reinforcement			
0330	Concrete Foundation			
0331	Concrete Slabs and Patios			
0335	Concrete Driveways			

0400	MASONRY			
0410	Stucco			
0421	Fireplace Masonry			
0422	Concrete Blocks			
0425	Fireplace Facing/Stone Mantel			
0442	Marble			
0445	Exterior Stone Veneer			
0500	METALS			
0510	Rough Frame Hardware			
0512	Structural Steel			
0570	Ornamental Stairs and Rails			
0600	WOODS AND PLASTICS			
0610	Rough Carpentry Labor			
0611	Framing/Sheathing Materials			
0619	Wood Trusses			
0620	Finish Carpentry Labor			
0622	Interior Millwork and Trim			
0640	Cabinetry			
0643	Wood Stairs and Railings			
0700	THERMAL AND MOISTURE PROTECTION			
0710	Waterproofing			
0720	Insulation			
0731	Roof—Composition Shingle			
0732	Roof—Tile			
0740	Exterior Siding			
0750	Roof—Membrane Build-up			
0760	Flashing and Sheetmetal			
0780	Skylights			
0800	DOORS, WINDOWS, AND GLASS			
0820	Exterior Doors			
0821	Interior Doors			
0830	Sliding Glass Doors			
0850	Metal Windows			
0860	Wood Windows			
0870	Finish Hardware			
0872	Garage Doors and Operators			
0883	Mirrors			

0900	FINISHES			
0925	Gypsum Drywall			
0930	Tile Countertop			
0934	Marble Countertop			
0938	Formica Countertop			
0960	Wood Flooring			
0961	Wood Mantels			
0965	Linoleum			
0968	Carpet			
0970	Tile Floor			
0990	Exterior Paint			
0991	Interior Paint			
0995	Wallpaper			
1000	SPECIALTIES			
1017	Tub and Shower Enclosures			
1030	Prefabricated Fireplace			
1040	Signage			
1080	Toilet and Bath Accessories			
1100	EQUIPMENT			
1105	Vacuum System			
1140	Kitchen Appliances			
1200	FURNISHINGS			
1250	Window Coverings			
1400	CONVEYING SYSTEMS			
1420	Elevators			
1500	MECHANICAL			
1540	Plumbing—Rough			
1545	Plumbing—Finish			
1546	Plumbing Fixtures			
1550	Fire Protection			
1580	Heating and Air Conditioning			
1600	ELECTRIC			
1610	Rough—Electrical			
1614	Finish—Electrical			
1650	Lighting Fixtures			
1670	Telephone and Prewire			
1676	Intercom and Prewire			
1678	Television and Prewire			

2000	MISCELLANEOUS			
	Cleanup			
3000	OVERHEAD AND PROFITS			
	Overhead			
	Profits			
	SUBTOTAL			
	Loan Cost			
	Insurance, Compensation, P.L. & P.D., Social Security & Unemployment Insurance			
	Builders Overhead and Profit %			
	TOTAL COST OF CONSTRUCTION			
	LAND COST			
	TOTAL			

I certify that to the best of my knowledge the above is a true and correct statement of the estimate cost of this job.

Signed: _____ **Date:** _____

Figure 12.1 An example of a project cost breakdown and budget estimate. To estimate the total project cost (TPC), it is necessary to include all hard and soft costs to fully execute the building as intended. TPCS include construction costs, contingencies, architect/engineer fee, owner services, and administrative fees. Depending on the general conditions and contract documents requirements, the TPC may also include infrastructure costs, furniture and equipment costs, instructional technology costs, moving costs, and other costs.

several factors including the complexity and size of the project and whether it is new construction or renovation, etc. For example, for large new construction projects the contingency is generally about 5% of the total cost, whereas for renovations, it may be roughly 7%. Likewise, for small interior projects, it may be as high as 10%. Any remaining contingency amounts can be released upon substantial completion of the project. However, it should be noted that in many cases neither the architect nor the contractor know the contingency amount in place. On this, the Engineering News-record says that “On average, owners share contingency information with their architects a little over half the time (58%) and with their contractors 43% of the time.” In Fig. 12.1, below is a sample project cost breakdown showing the main elements to be considered when preparing a budget estimate for the project.

The developer's, builder's or CM's fee is usually released as a direct percentage of the value of the subcontractual work completed to date.



12.2 BUDGET DEVELOPMENT—AN ANALYSIS

A project budget estimate is a financial plan to design and build a particular project and setting out the estimated costs to complete the project. Regardless of whether the project to be constructed is large or small, a prudent developer will certainly find it necessary to develop a budget for it. The primary purpose of preparing a budget is to understand and control costs and cost overruns. Cost overruns are mitigated by the inclusion of appropriate contingencies in the budget estimate to cover change orders, etc., and these contingency allowances are disbursed as the projects proceeds to cover the additional costs. Sometimes, construction budgets are formulated using only the “hard construction costs,” without any consideration for the “soft costs,” setting their maximum available amount of money at a level well below what will be necessary to satisfactorily complete the project as intended. Fig. 12.2 is a graph that illustrates the relationship of the contingency as a percentage of the direct cost budget.

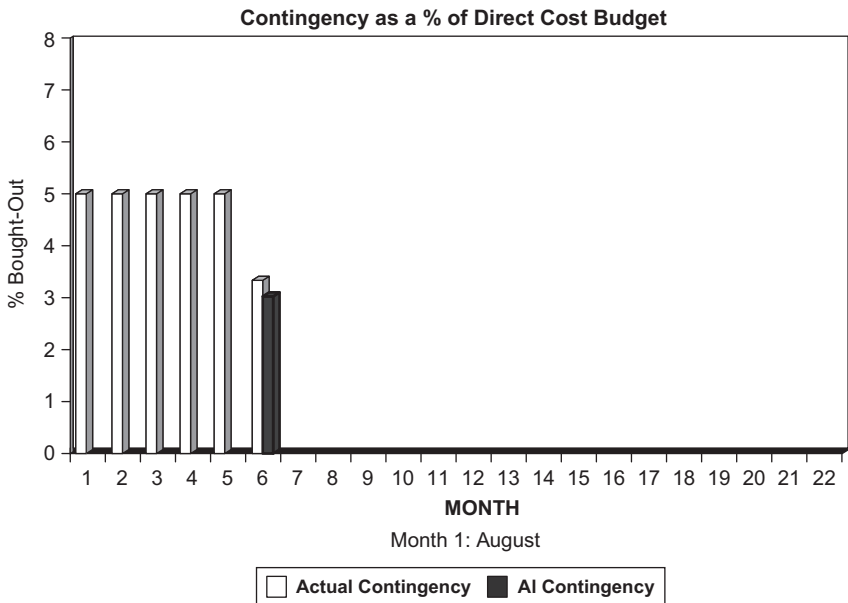

Figure 12.2 Graph illustrating relationship of contingency as percentage of direct cost budget as the construction process proceeds.

Randy White CEO of White Hutchinson Leisure & Learning Group says, “Many a project gets into serious trouble when, for whatever reason, the project can’t be developed within the budget. Usually, by the time the problem is discovered, it’s too late to increase the budget, as financing has already been secured. So to keep the project within budget, critical features end up being compromised, such as the theming, finishes, and the quality of the materials, furniture and equipment, the things that really matter the most to creating the guest experience. Or certain attractions are eliminated, so the project never performs as originally planned and projections are never achieved. In fact, such last-minute deletions and changes can seriously threaten a project’s very long-term survival.”

For obtaining a construction loan it is particularly important to have a Budget for the project in place. Thus prior to calculating the required construction loan amount, a basic budget is needed, the main components of which include:

1. Hard costs: direct costs associated with the labor and materials used for the actual physical construction costs of the project
2. Soft costs: indirect or “off-site” costs not directly related to labor or materials for construction (architectural plans, engineering, and permit fees)
3. Closing costs: all costs associated with origination and closing the construction loan such as title cost, loan fees, discount fees, insurance, appraisals, and closing fees
4. Land acquisition costs
5. Inspection fees
6. Reserves: consisting of estimated interest on the loan during construction and contingency reserve for unforeseen expenses and cost overruns
7. Possible equipment, furnishings, and other unforeseen necessities

As previously mentioned, the total cost of construction is obtained by adding all the costs incurred in the project including soft and hard costs. Most projects are constrained by limited monetary funding resources. Consequently, they need to have a budget in place to initially define its funding requirement. The project manager develops the budget based on the cost estimates calculated at the beginning of each project phase and refined once there is more accurate information defining the project’s scope. Refining the budget occurs through studies and analysis in the design development process. When Owners try to fix the budget too early in the project life cycle, they are surprised by the significant increases in the budget over what was set forth. Randy White says that “This reoccurring problem is often caused by the nature of the design process. Design proceeds

from general to specific and from conceptual to detailed. Accordingly, there is limited ability to accurately predict construction costs at the onset when initial project planning takes place and accurate costs are needed as part of the business plan to secure financing.” With respect to project cost overruns, White says, “Cost overruns are also caused by the traditional design-bid-build process. First the project is designed, and then a contractor is selected by either competitive bid or negotiation to build the project. This process precludes value engineering until the project is already designed. So by the time the bid comes in over budget, the only way to reduce costs is to make major compromises in finishes, quality or components.”

One of the critical tasks and assignments of the Project Manager (PM) is the development and tracking of the project budget. The PM first develops a project budget in the early feasibility phase and continues to refine it throughout the different project phases until the project is “bought out” by the general contractor prior to the start of the construction phase. All the elements of the budget should be clearly defined and fine-tuned throughout each phase. Specialized estimating software is often used to create, develop, monitor, and track budgets. When developing a budget, there are certain logical steps that should be followed:

Step 1: It is important to determine precisely how much money is available for the project when attempting to develop a project budget. This should include all costs from project initiation as a concept through the award of a construction contract to completion. At various points within the different stages, more detail, specificity and definition are developed and these estimates become more certain and realistic.

Step 2: Determine the mandatory or vital expenses for the project to succeed. Each project has certain requirements that are essential to the project’s success and these should be given priority in the project’s budget. For example, incorporating certain green features to achieve LEED certification is very important, which means that these should be high on the priority list for the project’s budget.

Step 3: Collect preliminary estimates from several companies and contractors. Upon having identified the key elements of the project budget, you can start requesting estimates from area businesses to determine which offers the best price or value for building the project. In any case, preconceived cost indices can often be unrealistic and misleading. Building a new building project in an urban setting, for example, is far more costly than on a green field site. Construction managers usually have a good understanding of true market conditions and pricing

in specific regions because their livelihood depends on it. Should your project budget not align with the project's expectations, then one or both will need realignment.

Step 4: Once the final budget is determined, it should be clearly spelled out and written down on paper and distributed to all the team members to ensure that everyone is on the same page. In the final analysis, it will also depend largely on the type of contract entered into between the owner and the contractor, e.g., whether it is a design-bid-build, design-build, cost-plus, etc.

Furthermore, total reliance on “program” and/or “preliminary” level estimates for setting a final project construction budget is inappropriate because it is far too early in the project's design/construction process. Until the time when a fairly accurate budget estimate can be developed, the project remains too conceptual in terms of scope and program size to accurately estimate final costs. After the Architect completes the schematic design phase, the project's scope of work is more clearly defined to the extent that a realistic budget estimate can be arrived at to provide effective discipline and direction on the project. However, this is still insufficient to bid the project and will not be able to do so until the contract documents are completed including all plans and specifications. The different phases or milestones a project must go through from design concept to completion and occupancy are:

1. Project Initiation Program Budget Estimate
2. Planning/Programming Preliminary Project Estimate
3. Design (Conceptual Design, Schematic Design Budget Estimate)
4. Contract Documents (Drawings, Project Manual, etc.)
5. Bidding of Contract, Awarding of Contract—Project Estimate
6. Construction Phase, Commissioning
7. Occupancy Phase.

Fig. 12.3 below is an example of preliminary construction budget for a typical project (new construction). This is an example of a project budget for a government agency that proposes to construct a new facility in which to expand its activities. It should be noted that these costs will vary depending on what region of the country the project is located.

Another example of a simple project budget is in Fig. 12.4 which is adopted from Charter School Facilities—A Resource Guide on Development and Financing, which shows the typical components of a project budget; it includes the purchase and renovation of a building as opposed to new construction.

SAMPLE CONSTRUCTION BUDGET

This is an example of a project budget for a government agency that proposes to construct a new facility in which to expand its activities. It should be noted that these costs will vary depending on what region of the country the project is located.

Expenses

Hard Construction Costs (8,000 SF @ \$97/SF)

Foundation, Framing, Drywall, Flooring, Roofing	\$581,000
Plumbing, Electrical, Security System	80,000
Fixtures, Furnishings, and Equipment	50,000
HVAC	27,000
Landscaping	19,000
Site Work	<u>18,000</u>
Subtotal Hard Costs	\$775,000
Land Acquisitions	175,000

Soft Construction Costs

Architect and Engineers	31,000
Fees	4,000
Subtotal Soft Construction Costs	\$35,000
Contingency	10,000
Total Expenses	\$995,000

Revenues

Individual Contributions	\$295,000
ABC Foundation	125,000
Government Grant	75,000
Corporate Donations	100,000
DEF Foundation	85,000
Other Foundations	65,000
XYZ Corporation (in-kind)	50,000
Other corporate donations	25,000
Fundraising Events	15,000
ABC Corporation	50,000
XYZ Foundation (pending)	50,000
To Be Raised from Other Sources	60,000
Total Revenues	\$995,000

Notes:

1. Hard construction costs include any costs that cannot be physically moved, in other words site work, renovations or construction work, plumbing, electrical, landscaping, parking lot, demolition, flooring, roofing, HVAC, wiring, fire and security alarms, playgrounds, fixtures, appliances, etc. that become a permanent part of the site.
2. Soft construction costs include fees, surveys, permits, architect and engineer fees, and so on.
3. Contingencies are usually between 5 and 10% of construction costs, depending on the size and complexity of the project.

Figure 12.3 A practical of a construction budget cost estimate for a government agency that is considering to construct a new facility to allow expansion of its activities. It should be noted that these costs can vary depending on what region of the country the project is located.

USES OF FUNDS:	
Acquisition of building	\$250,000
Construction/renovation Costs (hard costs)	
Demolition of old walls	75,000
Electrical	65,000
Plumbing	80,000
Heating/ventilation	40,000
Roof	50,000
Drywall and painting	140,000
Carpet	35,000
Windows	40,000
Fixtures and Fit-out	55,000
Site work	20,000
Total Construction:	600,000
Hard Cost Contingency (15%)	90,000
Total Acquisition & Construction:	940,000
Legal Fees	10,000
Appraisal	5,000
Architect	30,000
Project Manager	10,000
Engineering	5,000
Insurance during construction	3,000
Closing Costs	5,000
Financing fees (loan origination fee etc.)	7,000
Interest during construction	35,000
Inspection fees	5,000
Environmental studies	12,500
Accountant	5,000
Security	8,000
Bonding	6,000
Total:	146,500
Soft Cost Contingency (5%)	7,325
Grand Total:	\$1,093,825
SOURCES OF FUNDS:	
Start-Up Grant	\$150,000
Donations	238,325
Loan	705,500
Grand Total:	\$1,093,825

Notes:

1. Hard costs contingencies are anything related to the building structure or its materials. Large contingency budgeted is due to extensive nature of renovations. On average renovation projects have a 7–10% contingency and for new construction it is usually about 5%.
2. Soft costs are related to all other costs, including architectural, financing, inspection and legal fees. These costs are normally about 5% of the total project costs.

Figure 12.4 An example of a simple project budget adopted from charter school facilities—a resource guide on development and financing. Again it shows the typical components of a project budget and includes the purchase and renovation of a building as opposed to new construction.

12.3 PROJECT BUYOUT AND BID SHOPPING

Project buyout and bid shopping are two concepts familiar to most construction professionals. The term buyout, as it relates to construction project mobilization, basically refers to procuring materials and equipment that will be employed in the project and arranging subcontracts. Buyout is the time interval between the preconstruction and the construction phases of a project and is among the most critical first steps in the overall profitability of a construction project. And even before breaking ground, making or losing money could be predetermined based on how well the project is bought out. Also it is during buyout that purchase orders and subcontracts are issued. This includes selection of both suppliers and subcontractors and finalizing their purchase orders or subcontracts. Unfortunately, buyouts are necessary because often due to time constraints during the bidding phase of a project, complete, meticulous analyses of bids by subcontractors may not have been made. Fig. 12.5 is a diagram showing percentage of buyouts of budget's trade contract cost versus time.

Most construction literature ignores the issue of buyout and concentrates on addressing either estimating or project management. The process starts during the tender preparation stage, as the contractor solicits and

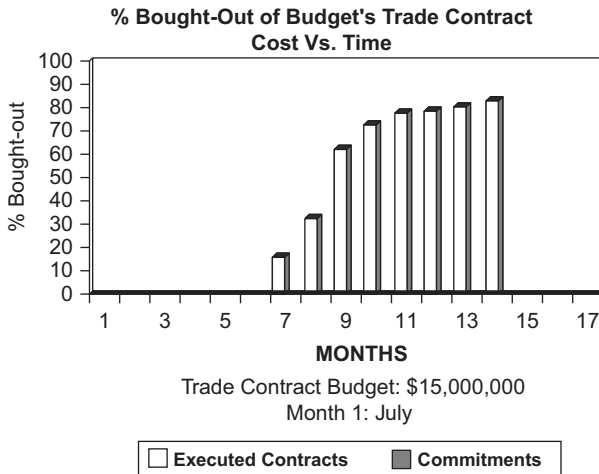

Figure 12.5 Diagram showing percentage of buyouts (executed and committed) of budget's trade contract cost versus time. The estimated budget in this case is \$15,000,000.

assesses offers in the process of assembling the cost estimate. Should the contractor's proposal be successful and the contractor is awarded the contract, the next step is to attempt to contract with the firm that submitted the best offer. Material procurement and subcontracting are typically the two distinct parts of the buyout process discussed, even though both may be the responsibility of a single department or individual.

Most construction professionals are familiar with the concepts of project buyout and bid shopping. Project buyout is an ethical and necessary practice conducted during the preconstruction process, which enables a general contractor to clarify scopes of work and streamline specific activities for the project. As construction professionals more fully understand the ethical issues separating the unacceptable practice of bid shopping from the ethical practice of project buyout, the efficiency and quality of the estimating and subsequent project management processes will be improved. Estimators are normally required to bear the responsibility of obtaining bids and performing project buyout while maintaining high ethical standards.

A buyout estimate is different from a bid estimate. A bid estimate is detailed to bid a project, whereas the purpose of a buyout estimate is to order materials once the project becomes a viable job for the contractor or subcontractor. A typical example of a bid estimate versus a buyout estimate would be metal studs for drywall. During the bid period, it is good enough to know the total linear footage of studs by size and gauge. A buyout however requires greater detail, for example, in addition to the bid information a buyout would require the lengths for each application. However, in mechanical and electrical scopes of work, the bid estimate and buyout estimates are very similar.

Project buyout takes place between the award of a bid to the general contractor and the issuing of subcontracts and purchase orders. While bid shopping is not illegal, it is considered an unethical practice where details of a bid are revealed to a competitor in an effort to solicit an overall lower bid. A better understanding of ethical versus acceptable construction practices can only help construction professionals identify the basic differences between bid shopping and project buyout while at the same time steering clear of unethical practices and still remain competitive.

According to Cody Andreasen, Mark Lords, and Kevin R. Miller, of Brigham Young University, "The justification, for some contractors, when arguing in favor of bid shopping is, that if a bid is revealed to another subcontractor, then a lower bid may be forth coming, which may translate into a lower overall bid on the project, benefit the owner, and thus increase the

likelihood of being awarded the project. It can be argued that this is no different than shopping for a car or bartering for goods in a foreign country. However, in the auto industry there is an expectation that pricing will be disclosed to other dealers in the buying process. That expectation does not exist in the construction industry. A construction project is something yet to be built. It is not an existing product and any changes in the cost typically will affect the quality or schedule of the project. Therefore, the owner is not receiving the same product if bid shopping occurs.”

Bid shopping essentially occurs when a general contractor discloses the bid price of one subcontractor or supplier to its competitors in an endeavor to obtain a lower bid than that on which the general contractor based the original bid to the owner. However, a technique that is often used to prevent bid shopping is for a subcontractor to submit a bid at the last minute, thus preventing the general contractor receiving the bid from shopping it.

By and large, bid shopping occurs because most subcontractors being shopped believe that if they do not reduce their price they will not get the job. Additionally, if business is slow, subcontractors may be willing to accept lower profit margins just to keep their crews busy even when it means they will only break even on the project. Sometimes, the general contractor will induce a subcontractor additional work upon being awarded the job. Although it may appear that the owner is the principal beneficiary of bid shopping by receiving a lower price for the project, usually one finds that the owner also receives a lower quality project in addition to running greater risks and warranty problems down the road. The Associated General Contractors of America (AGC) describes the practice of bid shopping as “abhorrent” and is totally opposed to it. These feelings are shared by the American Subcontractors Association (ASA), which considers bid shopping and bid peddling as unethical. This view is also shared by other contractor trade associations such as the AGC, ASA, and ASC. Moreover, this viewpoint appears to be shared by the courts that have opined on bid shopping.

The main benefits of project buyout according to the Brigham Young University authors are that “Project buyout allows a period of time for the contractor to ensure that each scope of work is covered by only one subcontractor. Occasionally a contractor finds that two subcontractors submitted bids for an overlapping scope of work. Since both subcontractors do not need to perform the work, the general contractor will determine which subcontractor will perform the work for the overlapping scopes. The subcontractor that does not perform the overlapping work will generally provide a credit to the general contractor for the reduction in their scope of

work. If the opposite is found and there has been work that was assumed to be included in a subcontractor's scope of work, but was not included in the bid, the general contractor generally negotiates with a subcontractor to have the work included in their subcontract and that negotiation may increase the contract amount for the subcontractor.

Another instance where changes could be made during the project buyout process results when a subcontractor anticipated a different project schedule than the general contractor. As a result, the subcontractor may not have sufficient crews to complete the job in the time frame or manner desired by the general contractor. In this case, the general contractor may elect to use a different subcontractor to maintain the project schedule.”

Darin C. Zwick and Kevin R. Miller authors of an article entitled, *Project Buyout* emphasize the importance of completing the buyout process as early as possible and say, “By completing buyout early, future delays are avoided in the event that a given scope of work is difficult to buyout due to conflicts with subcontractors or suppliers. It also protects the project from price escalation.

Other tasks that occur during the buyout process by the general contractor include checking the following items to ensure that the subcontractor can perform the work for the project:

- Insurance and liability coverage
- Evidence of state Workman's Compensation coverage
- Evidence of proper local and state subcontractor licenses
- Evidence of proper bonding requirements if required.

The expiration dates of the previous items need to be verified to prevent lapses of coverage while the subcontractor is working on the project.

Another consideration that companies need to examine during the buyout process is the financial stability of the subcontractors and vendors. During economic downturns, companies may declare bankruptcy, leaving the general contractors in a precarious situation.”

Among the main duties of the project buyout specialist is to focus on awarding scopes of work to subcontractors and to act as a liaison between field operations and subcontractors while keeping the contract amount in budget. This is particularly important because it relates to disputes and problems that often exceed field management's ability to solve matters in a timely manner. During the preconstruction phase, this includes technical support to both the design-build and estimating departments. In addition, the buyout specialist is responsible for the acquisition of new subcontractors for all projects including cost control, adherence to corporate and

contract compliance, quality control, and customer satisfaction. The project buyout specialist is also responsible for the quality and completeness of project buyout and small business utilization as well as customer relations and client satisfaction in all areas within the firm. To achieve maximum support for and from each staff member requires team building and a holistic approach. This includes setting and monitoring goals and collaborating with purchasing and operational goal setting. Over the last few years, there has been a significant wave of web and cloud apps, which are streamlining communication and simplifying and improving efficiency in construction management. For example, there are currently several proprietary buyout software packages on the market that can save time and reduce effort by automating the bid solicitation process. Buyout software also provides an important tool for determining where the project is in the buyout process at any particular moment. It can also establish the percent complete, minimize exposure, and rapidly see how the actual prices compare with the estimated costs. Moreover, it can offer access to standard cost codes, categories, and tax groups stored in various applications such as accounts payable applications. One example of such software is from Sage Software, Inc. (www.sagecre.com), which offers a software package called “Buyout” that reportedly has the following features (Fig. 12.6a):

- Builds a worksheet of material and subcontract items to be bought out automatically by reading the estimating file
- Combines multiple estimates into a single worksheet, an important feature for contractors who receive price discounts based on volume purchases
- Creates one-time items in the Buyout item window
- Views items the way you want to see them—by WBS, location, phase, material class, and so forth
- Groups materials or subcontract items for ease in obtaining prices. Create quote sheets and assign material items and subcontract items to the quote sheets
- Assigns multiple vendors and subcontractors to quote sheets
- Uses prices from Buyout’s standard price database for items in the quote sheet
- Automatically submits requests for quotes and sends purchase orders via e-mail, fax, or hard copy
- Splits items out of one quote for the creation of a new quote sheet
- Uses the Summary Quote sheet to organize vendors’ or subcontractors’ quotes from low to high

(a)

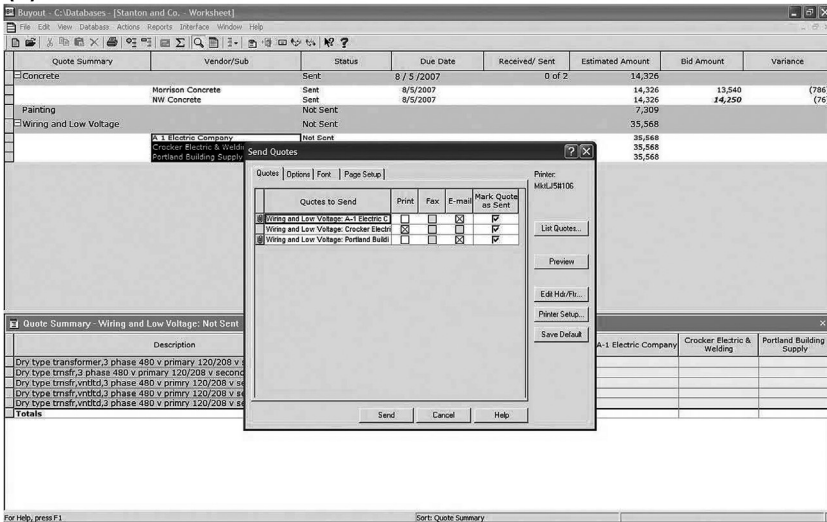

(b)

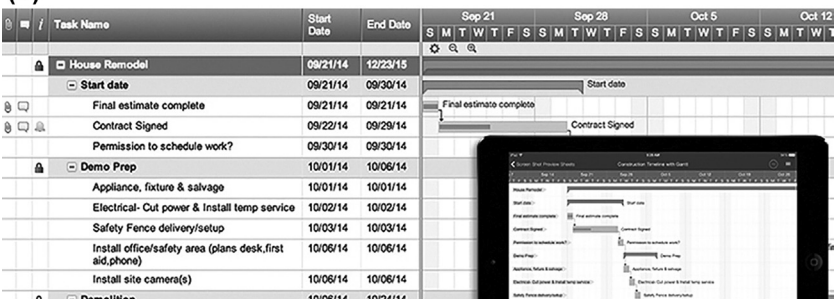

Figure 12.6 (a) an illustration of computer-based “buyout” software helps sort the items in an estimate into desired groups of materials, produce documents, and perform the tasks necessary to buy out a job. Amongst other features, it can automatically generate, sort, and send RFQs to suppliers, and subcontractors via e-mail, fax, or printed hard copy. It also records, tracks, analyzes, and selects bids received. One of the more important features is the ability to transfer commitments to purchasing for purchase order and subcontract generation. (b) smartsheet is a popular and effective construction management tool with excellent collaboration and communication features.

- Saves prices from the quote sheet to a Buyout standard price database
- Changes prices for any item and updates the estimating database with pricing from Buyout
- Generates Requests for Quotes (RFQs) and Purchase Orders (POs) directly from Buyout and issues them automatically via e-mail, fax, or hard copy
- Updates estimates with Buyout prices, revised quantities, and vendor/subcontractor selections.

Smartsheet is another popular spreadsheet-inspired work management tool with robust collaboration and communication features (Fig. 12.6b). The program has numerous prebuilt construction templates; likewise, it is not complicated to create a timeline, track progress, manage documents, and consolidate the details. Furthermore, with Smartsheet, Gantt charts are spontaneously created and adjust automatically whenever a change is made, thus keeping team members and stakeholders constantly up-to-date. In addition, team members can have discussions directly in the sheet and set reminders and alerts, so team members are always on the same page.



12.4 GENERAL CONDITIONS AND SUPPLEMENTAL CONDITIONS

The General Conditions are among the most important documents in the project manual because it sets forth and defines the rights and responsibility of the different parties, particularly the owner and contractor in the construction process as well as the specific terms of the contract. It also specifies and defines the surety bond provider, the design professional's role, authority, and responsibilities, and the requirements governing the various parties' business and legal relationships. These conditions are "general" and can apply to almost any project. It is vital that the contractor knows exactly what is contained in this section.

It should be noted that many trade and professional organizations have developed their own standard documents and general conditions. The most widely used may be those published by the American Institute of Architects (AIA), specifically AIA Document A201. This document has been well tested in the courts and is familiar to most contractors. The ConsensusDOCS 200, Standard Agreement and General Conditions between Owner and Contractor, is also widely used. Likewise, ConsensusDOCS 410, Agreement and General Conditions between Owner and Design-Builder [Cost of Work Plus Fee with Guaranteed Maximum Price (GMP)] is sometimes used. There are a number of standard clauses that typically appear in the general conditions. Below are some of the main standard clauses that typically appear in the General Conditions with a brief description of each (Bear in mind that they may vary depending on the type of general conditions contract):

Definitions and General Provisions: This clause provides definitions for the purpose of the Contract Documents relevant to the contracts, the work, and the drawings and specifications. It also clarifies the ownership, use, and overall intent of the contract documents.

Owner Responsibilities: This section defines the information and services that the owner is required to supply. It also defines the owner's rights and responsibilities and the owner's right to stop or carry out the work.

Contractor General Obligations and Responsibilities: This section lays out the obligations of the contractor regarding construction procedures and site operations, employees, labor and materials, warranty, taxes, permits, fees and notices, schedules, samples and product data, and cleaning up. This clause essentially states that the Contractor is required to execute and complete the Works and remedy any defects therein in strict accordance with the Contract, with due care and diligence and to the satisfaction of the Architect, and shall provide all labor, including the supervision thereof, materials, and all other things, whether of a temporary or permanent nature. The Contractor shall also take full responsibility for the adequacy, stability, and safety of all site operations and methods of construction, but the Contractor shall not be responsible, unless expressly stated otherwise in the Contract, for the design or specification of the Permanent Works or of any Temporary Works prepared by the Architect.

Administration of the Contract: This section describes the duties, responsibilities, and authority of the architect for the administration of the contract. Specific clauses are included dealing with the architect's responsibility for making periodic site inspections and issuing periodic reports to the owner or lender. This section also deals with issuing modifications in drawings and technical specifications and assisting the Contractor in the preparation of change orders and other contract modifications, as well as assisting in inspections, signing Certificates of Completion, and making recommendations with respect to acceptance of work completed under the contract. The Architect is also required to review detailed drawings and shop drawings, price breakdown, and progress payments estimates as well as how requests for additional time, claims, and disputes will be handled.

Preconstruction Conference and Notice to Proceed: This section deals with the procedures to conduct a preconstruction conference to acquaint the different parties with one another. For example, within 10 calendar days (or as stated in the contract documents) of contract execution, and prior to the commencement of work, the Contractor shall attend a preconstruction conference with representatives of the Owner, Architect, and other interested parties and stakeholders. This clause requires that the contractor can only begin work upon receipt of a written Notice to Proceed from the Owner or designee. The Contractor may not begin work prior to receiving such notice.

Availability and Use of Utility Services: This section deals with the availability of utility services. Here the Project Owner shall ensure that all reasonably required amounts of utilities are available to the Contractor from existing outlets and supplies, as specified in the contract. Unless otherwise provided in the contract, the amount of each utility service consumed shall be charged to or paid for by the Contractor at prevailing rates charged to the Owner.

Assignment and Subcontracting: This section deals with the assignment and awarding of subcontracts by the general contractor for portions of the work. This clause generally states that the Contractor shall not, except after obtaining prior written approval of the Project Owner, assign, transfer, pledge, or make other disposition of the Contract or any part thereof or of any of the Contractor's rights, claims, or obligations under the Contract. In the event the Contractor requires the services of subcontractors, the Contractor shall also obtain prior written approval of the owner for all such subcontractors. The approval of the Owner does not relieve the Contractor of any of his obligations under the Contract, and the terms of any subcontract shall be subject to and be in conformity with the provisions of the Contract.

Construction by Owner or Others: This clause deals with the owner's right to perform some of the construction work with his/her own forces or to award separate contracts to other parties besides the general contractor. The Contractor shall in accordance with the requirements of the Architect/Project Manager and the contract affords all reasonable opportunities for carrying out portions of the work by the owner or to any other contractors employed by the owner and their workmen or the owner's workmen who may be employed in the execution on or near the Site of any work not included in the Contract or of any contract which the Owner may enter into in connection with or ancillary to the Works.

Permits and Codes: This section basically states that the Contractor shall give all notices and comply with all applicable laws, ordinances, codes, rules, and regulations. Before installing the work, the Contractor shall examine the drawings and the specifications for compliance with applicable codes and regulations bearing on the work and shall immediately report any discrepancy it may discover to the Architect/Project Manager.

Change Orders: This section explains how changes are authorized and processed according to the relevant clauses of the contract. Changes orders are one of the areas of greatest contention between the owner and the contractor. Generally, the Architect may instruct the Contractor, with the approval of the Owner and by means of Change Orders, all variations in

quantity or quality of the Works, in whole or in part, that are deemed necessary by the Architect. Processing of change orders shall be governed by appropriate clauses of the General Conditions.

Construction Progress Schedule: Time is always a pivotal factor on any project. Project schedules depict project start-up, progress, and anticipated completion dates. It also addresses issues associated with delays and extensions of time to the contract. For example, schedules shall take the form of a progress chart of suitable scale to indicate appropriately the percentage of work scheduled for completion by any given date during the construction period.

Progress Payments: This section specifies how applications for progress payments are to be processed. It states that the Owner/Lender shall make progress payments approximately every 30 days as the work proceeds, on estimates of work completed and which meets the standards of quality established under the contract, as approved by the Project Manager/Architect. Before the first progress payment can be processed under this contract, the Contractor shall furnish a breakdown of the total contract price showing the amount included therein for each principal category of the work, which shall substantiate the payment amount requested to provide a basis for determining progress payments. This section also deals with the withholding of payments and failure to pay issues.

Protection of Persons and Property: This section is intended to address issues relating to safety of both the project owner's property and the people on the project. It deals with specific issues such as the handling of hazardous materials and emergencies, as well as overall safety programs and requirements. The Contractor shall (unless stated otherwise in the contract) indemnify, hold, and save harmless and defend at his/her own expense the project owner, its officers, agents, and employees from and against all suits, claims, demands, proceedings, and liability of any nature or kind, including costs and expenses, for injuries or damages to any person or any property which may arise out of or in consequence of acts or omissions of the Contractor or its agents, employees, or subcontractors in the execution of the contract.

Insurance of Works and Bonds: This section deals with insurance (including liability insurance) and bonding requirements of the various parties and which should cover the period stipulated and also cover the Defects Liability Period for loss or damage arising from a cause occurring prior to the commencement of the Defects Liability Period and for any loss or damage experienced by the Contractor in the course of any operations carried out for the purpose of complying with the contract obligations.

Examination of Work Before Covering Up: This clause has to do with acceptance of the work by the architect (as agent of the owner). It stipulates how and when the contractor is responsible for uncovering and/or correcting any work deemed unacceptable. Therefore, no work shall be covered up or put out of view without the prior approval of the Project Manager/Architect. The Contractor shall afford full opportunity for the Project Manager/Architect to examine and measure any work which is about to be covered up or put out of view and to examine foundations before permanent work is placed thereon. The Contractor shall give due notice to the Project Manager/Architect whenever any such work or foundations is ready for examination and shall without unreasonable delay advise the Contractor accordingly to attend for the purpose of examining and measuring such work.

Clearance of Site on Substantial Completion: This section essentially stipulates that upon the substantial completion of the Works the Contractor shall clear away and remove from the Site all rubbish, constructional plant, surplus materials, and temporary works so as to leave the whole of the site and works clean and in a workman-like condition to the satisfaction of the Project Manager/Architect.

As-Built Drawings: “As-built drawings,” as used in this clause, refers to drawings submitted by the Contractor or subcontractor at any tier to show the construction of a particular structure or work as actually completed under the contract. “As-built drawings” shall be synonymous with “Record drawings.”

Miscellaneous Provisions: This section deals with various matters such as liquidated damages, taxation, disputes, prohibition against liens, warranty of construction, energy efficiency and other green issues, waiver of consequential damages, etc.

Termination/Suspension of the Contract: Either party has the right to terminate the contract under certain conditions. The conditions under which the parties may terminate or suspend the contract are clarified in this clause. For example, the Contractor shall on the written order of the Architect/Project Manager suspend the progress of the Works or any part thereof for such time or times and in such manner as required by the Architect/Project Manager and shall, during such suspension, properly protect and secure the Works as specified by the Architect/Project Manager. The Project Owner should be notified and written approval sought for any suspension of work in excess of 3 days.

12.4.1 Supplemental Conditions

These are special conditions also known as supplementary general conditions, special provisions, or particular conditions, that normally deal with matters that are project specific and which are beyond the scope of the standard General Conditions. These sections may either add to or amend provisions in the general conditions. Examples of project-specific information that may appear in the supplemental conditions include:

- Safety and protection requirements
- Scheduling
- Contractor's bond requirements
- Bonus payment information
- Defects liability period
- Cost fluctuation adjustments
- Progress payment retainage
- Services provided by Owner
- Temporary facilities provided by Owner
- Owner provided materials
- Cleanup and restoration.



12.5 CONTINGENCIES AND ALLOWANCES

There are many definitions for a “Contingency”. For example, The Association for the Advancement of Cost Engineering defines contingency as “An amount added to an estimate to allow for items, conditions, or events for which the state, occurrence, or effect is uncertain and that experience shows will likely result, in aggregate, in additional costs.” David H. Hart, AIA, describes contingency as “a predetermined amount or percentage of the contract held for unpredictable changes in the project.” He goes on to say, “A contingency is a helpful risk management tool that financially prepares owners for addressing risk within the project.”

From the above, it is clear that contingencies are generally necessary to cover unknowns, unforeseen, and/or unanticipated conditions or circumstances that are not possible to adequately evaluate or determine from the information on hand at the time the cost estimate is prepared. Contingency allocations specifically relate to project uncertainties of the current known and defined project scope and that may arise and are not a prediction of future project scope or schedule changes. The amount of contingency

allocated relates to the amount of assessed risk and should not be reduced without appropriate supporting justification. Furthermore, inclusion of a contingency amount in the cost estimate mitigates the impact of cost increases inherent in an overly optimistic estimate and provides for the opportunity of an earlier discussion of how to address potentially adverse circumstances.

Contingencies in a project budget represent the degree of risk within the estimate and are traditionally calculated as an across-the-board percentage addition on the base estimate, typically based on initial estimates, previous experience, and historical data. This estimating approach has serious flaws because it is generally illogically arrived at and therefore often not appropriate for the project at hand. Moreover, this method of arbitrary contingency calculation is difficult for an estimator to justify or defend. A percentage addition results in a single-figure prediction of estimated cost, which is often unjustified because it does not reflect reality nor does it encourage creativity in estimating practice.

Examples of typical contingency types normally found in budgets and that should be considered when major projects are involved:

- **The Owner's Contingency:** It is virtually impossible to produce a perfect set of construction documents, leaving room for miscalculations and omissions, which is why applying a standard amount to each project can lead to cost overruns, accusations, and litigation. And it is very important to adequately establish an allowance of the right size, that is neither too low nor too high. An owner's program almost always changes, if only marginally, during the life of a project, and changes or modifications to the scope of work typically occur in response to internal programmatic changes. The contingency is one way to mitigate the impact of changes in scope or errors and omissions.
- **Construction contingency** is basically used to cover cost growth during construction. It is a percentage of construction cost held by the PM to resolve issues during construction, which is why it should not be used until the project is in the construction phase. Having a contingency for the contractor's needs will vary with the type of delivery method. This contingency will be higher for renovations in older buildings, buildings with complicated site conditions, or in complex projects. The construction contingency is contained in the contractor's GMP but the PM must approve use of these funds prior to being committed by the general contractor.

- Design contingency is for changes or modifications during the design process for such factors as incomplete scope definition and inaccuracy of estimating methods and data. Design contingency amounts are based on the amount of design completed and are a percentage of construction cost held to represent the completeness of the design. The design contingency is understandably higher during the early phase of the project's design. As the design is completed and the scope of work is more defined, this contingency is reduced until it becomes zero in the cost element at the completion of the permit phase.
- Project contingency is a percentage of project cost retained for risks in other project costs such as professional fees, hazardous materials abatement (e.g., asbestos), communications wiring, etc. Money allocated as contingency in the project budget should not be utilized for additional scope or other changes to the project once the design is completed.
- Program contingency is optional and may be employed to cover scope or program changes requested by the User Group or owner. An alternative to this contingency is to have the General Contractor carry an *allowance* line item in the GMP contract.
- Various other contingencies for areas or items that may show a high potential for risk and change, i.e., environmental mitigation, utilities, highly specialized designs, etc.

12.5.1 Construction Contingencies

As previously mentioned, the construction contingency is essentially a set percentage of the construction contract amount budgeted for unexpected and unforeseen emergencies or design shortfalls identified after a construction project has commenced. When underwriting a commercial construction loan request, it is prudent to analyze the four major elements of the total construction cost which are the land cost, the hard costs, the soft costs, and the contingency reserve. Since there are always cost overruns in almost any commercial construction process, a contingency reserve is put in place to build in a cushion in the project's construction budget to cover these cost overruns. And while there is no specific formula for computing a contingency reserve, many underwriters feel comfortable using 5% of the construction estimate/bid for new construction (although in complicated projects the contingency can be as high as 10%) and 7% of the construction estimate/bid for remodeling/renovation projects. The land costs are not included because it is usually known in advance and is fixed. It is therefore unlikely that there will be a cost overrun connected to the purchase of the land itself.

A construction contingency is included in the budget to allow the project to proceed with minimal interruption for small or insignificant (non-scope) changes or cost overruns. The typical construction contract will include a specific completion date or specific number of working days to complete, and the contractor can be required to pay liquidated damages if the work is not completed within this specified period. At the same time, the contractor is entitled to proceed with the work without undue interruption. To minimize delays due to external causes, the client must be capable of implementing minor (i.e., nonscope) changes without causing any administrative delay.

Whatever the case, changes are always likely to occur on construction projects. The owner must therefore ensure that an appropriate contingency is included to cover the costs of any changes in the scope of a project, such as adding upgrades, additional equipment or perhaps enlarge the footprint of the building. Moreover, financing costs may change with the market. A small contingency may be sufficient to cover final documentation of drawings by designers, but the owner should plan for a construction contingency of roughly 3% to cover the changes in market conditions, and potential variances.

The objective of contingency planning is to determine a confidence value by means of a percentage in potential cost and schedule growth. The contingency value is an indicator of the level or degree of project development, and typically, the less defined a project, the higher the contingency value. Issues such as scope definition and quality assurance have a significant impact on confidence, risks, and resulting contingency development. In determining a contingency value, consideration must be given to the details and information available at each stage of planning, design, and construction for which a cost estimate is being prepared.

As previously mentioned, most construction budgets contain an allowance for contingencies or unexpected costs occurring during construction. This contingency amount may either be included within each cost item or be included as a single category in the construction contingency. The estimated amount of contingency to be retained is based on historical experience and the anticipated difficulty of a particular construction project. For example, one construction firm places estimates of the anticipated cost into five specific categories. These are:

- Design development changes,
- Schedule adjustments,
- General administration changes (such as wage rates),

- Differing site conditions for those expected, and
- Third-party requirements imposed during construction, such as new permits.

Any contingent amounts not disbursed during construction process can be released toward the end of construction to the project owner or alternatively used to add additional project elements. The construction cost process consists of two essential components, *Hard Costs* and *Soft Costs*.

Hard Costs are considered to be by far the largest portion of the allocated expenses in a construction budget and generally consist of all of the costs for physical items and visible improvements (i.e., actual construction costs incurred to build the project), line items including site preparation (grading/excavating), concrete, framing, electrical, carpentry, roofing, and landscaping. Hard costs are often referred to as the bricks and mortar expenses. In some cases, it may include the land, but that particular cost is usually separated to find out the actual construction expenses.

Soft Costs are the nonphysical expenses and involve all of the other fees involved in the completion of the project. Typical soft costs include architecture and engineering fees, as well as soft costs transfer taxes, origination points, mortgage insurance (if applicable), overhead expenses, attorney fees, professional fees, permits, title insurance, appraisal fee, testing, hazard insurance, marketing, construction insurance, etc. Another primary soft cost category if applicable is that of fixtures, furnishing, and equipment (FF&E). Soft costs can also be expenses that continue even after a project is completed, such as building maintenance, insurance, security, and other ongoing fees needed for an asset's upkeep. One soft cost that has in recent years become much more prevalent is LEED certification for commercial real estate projects, particularly as more municipalities are offering incentives for green buildings and developers recognize the long-term savings from owning sustainable assets. Generally speaking, the soft costs are estimated as a percentage of the total project budget during the planning stages of a project. And as the planning and design of a project progresses, the soft cost contingency percentage can be increased or decreased.

To arrive at the total cost of a commercial construction project, one must include the hard costs, soft costs, the cost of land, as well as the contingency reserve, which for new construction is generally about 5% of the TPC.

Design professionals are able to establish a project costs estimate by the employment of several methods. For example, one approach is to use estimates whose development is based on project parameters and major cost elements, or which are based on an analysis of historical bid data, actual

cost, or a combination of these methods. But whatever method is used, in the final analysis, special care must be taken to ensure that the capital cost estimate undertaken is complete and is realistic and not over optimistic. Underestimation of project construction and related costs is one of the more common problems faced in the economic analysis and budgeting of a project. Contingency funding is a fiscal planning tool that is used to help manage the risk of cost escalations and cover potential cost estimate shortfalls. Inclusion of a contingency amount in the cost estimate will mitigate the adverse impact of cost increases inherent in an overly optimistic estimate and provide an opportunity for an earlier discussion of how potential circumstances can be addressed.

Having an overall management contingency is strongly advised for large projects. This contingency is usually a “stand-alone” amount of the cost estimate that is managed by an executive and used for a broad array of uncertainties and potential risks. Some of the Project Oversight Management contingency allowance will be disbursed to manage costs, manage the approved budget and schedule deviations, address adverse impacts caused by modifications, and for initiatives being analyzed or implemented to address or mitigate potential cost overruns or schedule delays.

Management of the transfer of costs to and from contingency and allowance line items needs to be administered and tracked carefully to allow decision-makers to take appropriate action. Cost transfers should correspond to the major component type of cost escalation. Thus if a proposed work is clearly outside of a well-defined scope but is found to be essential to the well-being of the project and can be readily justified, then a management decision can be made to disburse payment for the added work or change order from either the management contingency or another appropriate contingency. On the other hand, if there are distinct fees or FF&E issues that have a fees or FF&E contingency, careful tracking of these particular contingencies can help the PM and management to better analyze potential cost overruns. The rationale for supporting contingency transfers should be noted and incorporated into all relevant reporting. This is to allow a periodic comparison analysis of available contingency amounts to establish contingency usage rates. This analysis will alert project managers if potential problems exist as well as confirm if a reasonable and sufficient amount of contingency remains to keep the project within the latest approved budget.

Construction cost estimates should not be presented as a lumpsum total, but rather as the sum of costs for each major element of the project. The contingency allowances can be clearly identified as individual line items

associated with each major element. This allows the PM and reviewers of future updates to track where and how project costs are changing and how they may impact the completion of the project. This may be achieved by providing information on reoccurring patterns and reasons behind cost escalation. Contingencies are normally disclosed as a dollar value or a percent of the major element cost.

12.5.2 Budget Allowances

Budget Allowances are generally similar to contingencies in that their purpose is to reserve funds for circumstances that are ill-defined and thus more prevalent in the earlier design phases of a project when the uncertainties are most evident. However, unlike contingencies, Allowances are usually identifiable single items/issues and are placed in budgets as individual line items. Certain Allowances may also be carried by the General Contractor upon attaining the approval of the PM and provided they do not exceed their budgets or estimates to cover such items that they believe may arise (based on prior experience). Furthermore, as an optional allowance, the General Contractor may also carry a contingency to cover scope or program changes that the User Group/Owner may request during construction. This Allowance is an agreed upon amount between the Contractor and the PM and must be approved by the PM prior to being committed by the Contractor. The PM can carry Allowances in any of the Cost and Time Summary categories for questionable or additive alternate construction and nonconstruction items as necessary.

In discussing allowances, Sabo & Zahn, Attorneys at Law state that “An allowance is a line item in a construction budget that serves as a placeholder during the bidding and initial construction contract phase. It is used when a particular item to be used in the construction has not been picked or completely specified. For example, if the carpeting has not been selected at the time of bidding, rather than delay the bidding, an allowance for the carpeting can be used. Normally, in this situation the total amount of carpeting to be used is known. If, for instance, the house will have 300 yards of carpeting, with a \$50 persquare yard allowance, the contractor will include a carpet allowance of \$15,000 in the bid. This allowance will cover the cost of the materials as well as the cost of installation. The contractor will also have its overhead and profit included in the proper category. At some later date, the owner will pick the actual carpeting. If the actual cost for that carpeting is \$60 per yard, then the contractor will be entitled to a change order for the increased cost—in

this example, \$3000. On the other hand, if the actual cost of the carpeting turns out to be only \$40, then the change order will reflect a deduct of \$3000.

The key to properly administering allowances is to account for them by proper change orders. At the time that the actual material is selected and approved by the owner, a change order must be issued and signed. This change order must indicate that the allowance for that item is being deleted, with a credit to the contract for the allowance amount, with a corresponding increase in the construction cost in the amount of the actual cost. In our example with a \$60 carpet cost, the allowance of \$15,000 would be credited to the owner and the \$18,000 actual cost would be added to the contract, for a net increase of \$3000.” However, the best practice is not to provide any allowances if possible, but instead ensure that everything is clearly identified and specified prior to solicitation of bids.

In this respect, the allowance section of AIA Document A201-1997 states that, “The Contractor shall include in the Contract Sum all allowances stated in the Contract Documents. Items covered by allowances shall be supplied for such amounts and by such persons or entities as the Owner may direct, but the Contractor shall not be required to employ persons or entities to whom the Contractor has reasonable objection.”

The AIA Document A201-1997 also states that, “Unless otherwise provided in the Contract Documents:

1. allowances shall cover the cost to the Contractor of materials and equipment delivered at the site and all required taxes, less applicable trade discounts;
2. Contractor’s costs for unloading and handling at the site, labor, installation costs, overhead, profit and other expenses contemplated for stated allowance amounts shall be included in the Contract Sum but not in the allowances;
3. whenever costs are more than or less than allowances, the Contract Sum shall be adjusted accordingly by Change Order. The amount of the Change Order shall reflect (1) the difference between actual costs and the allowances under Clause 3.8.2.1 and (2) changes in Contractor’s costs under Clause 3.8.2.2.”

The AIA document further stipulates that materials and equipment under an allowance shall be selected by the Owner within sufficient time to avoid causing delay to the Work. This means that if the additional time caused by the delay is sufficiently significant, the contractor may be entitled to additional compensation due to that delay.



12.6 GREEN PROJECT COST MANAGEMENT

Optimum results are most often achieved when the project's activities are integrated and costs are managed collaboratively. The integrated project team should always be engaged at the earliest phases of design, using target costing, value management, and risk management. Owners/developers are sometimes tempted to put in place a guaranteed maximum price on the project before the design stage is complete, but this should be resisted to ensure quality and functionality for the building owner or stakeholder. If the project owner comes under pressure to seek a fixed price at an earlier stage of the process, it would be prudent to agree on an incentive scheme for the sharing of benefits. It goes without saying that the owner should have a clear understanding of actual construction costs, both hard and soft costs. Likewise, the owner and project manager must be able to identify and differentiate between underlying costs and risk allowances in addition to being able to distinguish between profit and overhead margins.

12.6.1 Successful Cost Management Procedures

The project manager (PM) is generally responsible for management of the running and overall cost of the project and who in turn reports regularly to the owner (or lender, depending on the contract documents). One of the project manager's responsibilities is to maintain ongoing reviews of designs as they develop and provide advice on costs to the integrated project team as well as receive feedback from the project team. This continuous cost oversight is of particular benefit in assessing individual decisions and is especially useful on large and complex schemes. It may also prove useful to schedule in periodic formal assessments of the whole scheme, as budgetary estimates, at each phase of the project (Fig. 12.7). The roles and responsibilities and limits of authority for the project manager's role should be clearly agreed upon at the start of the project, so that everyone knows exactly what the PM is empowered to do in managing project costs and cost overruns.

The UK Office of Government Commerce indicates that the main ingredients for successful project cost management are:

- to manage the base estimate and risk allowance
- to operate change control procedures
- to produce cost reports, estimates and forecasts. The project manager is directly responsible for understanding and reporting the cost consequences of any decisions and for initiating corrective actions if necessary
- to maintain an up-to-date estimated outturn cost and cash flow

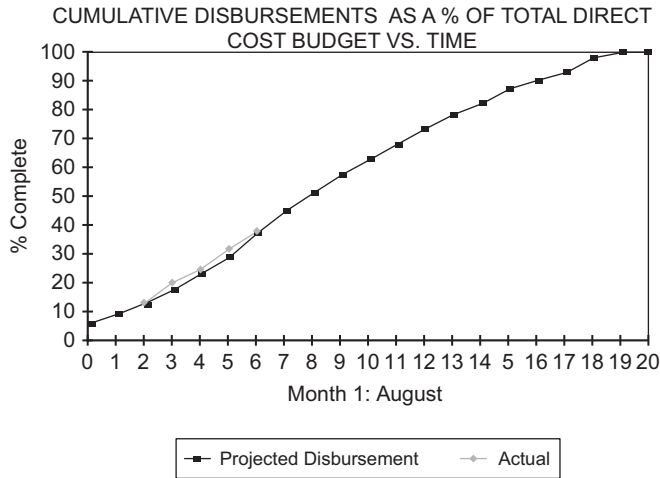

Figure 12.7 An example of a cumulative disbursements schedule as a percentage of total direct cost budget versus time and based on the current project budget and 20.5-month construction period. The CM's projection of disbursements is shown plotted in the graph and generally follows a realistic "S" curve. The project's cumulative net direct cost disbursements to date indicate being roughly in line with initial budget estimates.

- to manage expenditure of the risk allowance
- to initiate action to avoid overspend
- to issue a monthly financial status report.

Additionally, the cost management objectives during the construction phase include delivery of the project at the appropriate capital cost using the value criteria established at the project's inception and ensuring that throughout the project, comprehensive and accurate accounts are kept of all transactions, payments, and changes.

Likewise, the UK Office of Government Commerce also believes that the chief areas that cost management teams should consider during the design and execution of a construction project are:

- Identifying elements and components to be included in the project and constricting expenditure accordingly.
- Defining the project program from inception to completion.
- Making sure that designs meet the scope and budget of the project and delivering quality is appropriate and conforms to the brief.
- Checking that orders are properly authorized.
- Certifying that the contracts provide full and proper control and that all incurred costs are as authorized. All materials are to be appropriately specified to meet the project's scope and design criteria and that materials can be procured effectively.

- Monitor all expenditure relating to risks to ensure that it is appropriately allocated from the risk allowance and properly authorized. Also monitor use of risk allowance to assess impact on overall outturn cost.
- Maintaining strict planning and control of both commitments and expenditure within budgets to help prevent any unexpected cost over/under runs. All transactions are to be properly recorded and authorized and where appropriate, decisions are justified.

12.6.2 Risk Allowance Management

It should be no surprise that the construction business can be very risky for the owner as well as the contractor; this is due mainly to the plethora of risks caused by unexpected and noncontrollable issues, explaining why risk allowances are needed to be put in place. Risk allowances should be managed by the party that is in the best position to manage the risks, which is usually the project owner or someone representing the owner, with the advice and support of the project manager. What risk allowance management essentially consists of is a procedure to move costs out of the risk allowance column into the base estimate for the project work either as risks materialize or actions taken to manage the risks. Formal procedures are required to be put in place for controlling quality, cost overruns, project delays, and change orders. Risk allowances should not be disbursed unless the identified risks to which they relate actually occur. When risks occur that have not previously been identified, they should be treated as change orders to the project. Likewise, risks that materialize but have insufficient risk allowance allocated for them should also be treated as change orders (variation orders).

Fig. 12.8 is a graph that is designed to assist the PM and owner in monitoring the key elements of the project as well as present an overall picture of how the project is progressing. It should be noted that the graph is to be supplemented with notes for each key element. For example, “**Site Work:** The site has been cleared. The north waterline connection, and two (2) north and two (2) south sanitary connections have been installed and stubbed through the foundation wall. Electrical connections to the temporary switchgear have been made. A temporary concrete sidewalk has been placed along Washington Avenue.”

It is always preferable to define potential risks by allocating specific costs to them, as opposed to just inflating the total cost to compensate for inadequate early planning. A risk-allocated cost contingency is normally needed and included in the TPC estimate to help mitigate potentially significant

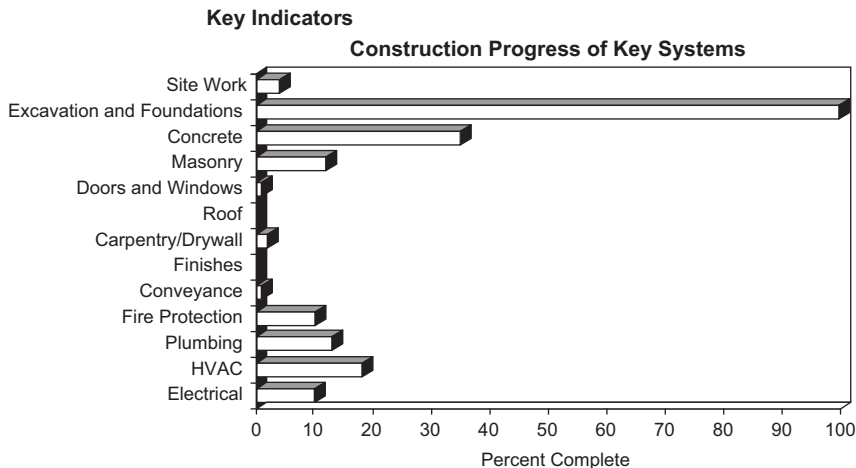

Figure 12.8 Graph designed to assist the Project Manager and Owner in monitoring the key elements of the project as well as present an overall picture of how the project is progressing.

risks. Risk management and contingency funding is particularly useful for mitigating those risks that cause cost escalations and project cost overruns during the course of a project's execution.

In the process of preparing the initial project budget, it is strongly recommended to perform a risk assessment on the entire project to identify and quantify the potential risk areas and types. This will help mitigate the uncertainties and help create a conservative cost expectation. Risk assessments should also be performed on a regular basis throughout the project's execution and to update contingency amounts. Examples of risk assessment areas that may cause concern include failure to perform, analysis of heterogeneous or irregular site conditions, utility impacts, hazardous materials, environmental impacts, third-party concerns, etc. When quantifying risk as a contingency amount, expectation of occurrence, severity, and anticipated dollar value are variables that may be considered and utilized. After all known risk mitigation, the budget's cost estimate contingency allowance levels should reflect the actual amount of remaining risk associated with the project's major cost elements. An overall management contingency can also be included to cover unknown, unanticipated risks.

Risks and risk allowances should normally be reviewed and evaluated on a regular basis, particularly when formal estimates are prepared, from the design, construction phases through substantial completion and occupancy. The introduction of changes after the briefing and outline design stages

are complete should be avoided as much as possible. Change orders can be minimized by ensuring that from the start of the project the contract documents are as clear, complete, and comprehensive as possible and that it has been approved by the stakeholders. This may require early meetings with planning authorities to discuss their requirements and to ensure that the designs are adequately developed and coordinated before construction begins. For renovation of existing buildings the type of risks may differ slightly and may require site investigations or condition surveys.

12.6.3 Cost Planning

Over the years, we have witnessed many ups and downs in the construction industry. During economic downturns, the construction industry experiences more than its fair share of bankruptcies. Many of these bankruptcies could have been prevented had the project owner and Project Manager taken adequate precautions. Perhaps the primary cause of bankruptcies is due to inadequate cash resources and failure to convince creditors and the main project lender (if the project is financed) that this inadequacy is only temporary. The need to forecast cash requirements and a project's expected cash flow (i.e., transfer of money into or out of the firm) is important for the project to succeed, particularly if there are cost overruns, economic recession, etc. Cash flow planning can take many forms but is necessary as there will always be a time lag between an entitlement to receive a payment for work executed and actually receiving it.

In an elemental designed cost plan the estimate is broken down into a number of components that can then be compared with later estimates, or with actual costs as the project progresses. In applying this approach, each element or item is treated as a distinct cost center, although money can be still be transferred between elements as long as a reasonable balance between elements is maintained and the overall target budget is maintained. It must be emphasized that green buildings require intensive planning to ensure optimal results, but any additional effort is usually worth it if you consider that operating costs will be substantially reduced over the life of the facility.

The primary function of a cost plan is to allocate the budget to the main elements of the project and to provide a basis for cost control. The term budget and cost plan are sometimes mistakenly considered to have the same meaning. However, there is a difference which is that the budget reflects the limit of expenditure defined for the project, whereas the cost plan defines what the money will be spent on and when. A cost plan should, therefore, include the best possible approximation of the cash flow for the project and

which should also include targets set for future running costs. The cost plan should therefore cover all stages of the project and will be the critical reference against which the project costs are managed. Most often, the initial cost plan is based on unsubstantiated estimates, which nevertheless provide a fair basis for determining the validity of future assessments. The project manager is able to control costs by instituting ongoing reviews of estimates for each cost center against its target budget. Fig. 12.9 is a practical example of a detailed cost estimate with comments on the right. It is interesting to note some of the buyouts and line items that appear low or acceptable. As the project design continues to develop and is priced, variances in cost from the initial cost plan is noted and recorded. A decision must then be taken as to whether that item can be authorized with a corresponding increase in cost, which would then require an equal reduction elsewhere, or whether the element in question needs to be redesigned to keep within the proposed budget. Furthermore, if a lender is involved, the Consultant or PM needs to check the Lender's policy to determine if funding of contract deposits are permitted on such subcontracts as structural steel, precast panels, curtain wall systems, etc. In most cases, the Lender's policy is to refrain from funding deposits. A development budget study on the other hand is undertaken to determine the total costs and returns expected from a specific project.

On the majority of projects however, it is the owner's designated representative that has overall responsibility for general management of the project, including the estimated cost, and therefore has to be satisfied that appropriate methods are in place for controlling the project's cost. Where the design process requires the allocation of a significant amount of money, such costs should be appropriately assessed against the budget amount and properly authorized. To facilitate matters, the owner's representative will frequently delegate an appropriate degree of financial authority for design development decisions to the integrated project team. For particularly large or complex projects the owner may decide to change the delegated levels for each cost center. The payment process is typically managed in the same manner as the design/construction process. All payments should be made as per the contract agreement and on time. Payments for change orders, provisional sums, and so forth should only be discharged after formal approval is given and as the work is executed.

However, once the construction process begins any instructions issued to the integrated project team, requesting a change through a formal change order procedure can have a pronounced impact on the project's cost and possibly other impacts such as time delay. This is why the project

XYZ Office Building—Leesburg, Virginia
ABC Project No. A708 November

Site Area (Acres): 26,310

Building Area (SFG): 358,000

Item of Work	Borrower's Budget (\$)	\$/SFG	\$/ACRE	% Total	Comments
Mass Grading	0	0.00	0	0.00%	By previous land owner
Fine Grade and Spoil Removal	240,000	0.67	9,122	0.95%	OK-Bought Out
Site Concrete	230,000	0.64	8,742	0.91%	OK-Bought Out
Asphalt Paving, Striping and Signage	460,000	1.28	17,483	1.83%	Seems Low
Landscaping Allowance	75,000	0.21	2,851	0.30%	Seems Low-Allowance
Site Irrigation Allowance	25,000	0.07	950	0.10%	Allowance
Parking Equipment	60,000	0.17	2,280	0.24%	Seems High
Site Plumbing	334,500	0.93	12,713	1.33%	OK-Bought Out
Site Electrical	93,250	0.26	3,544	0.37%	Low-Buy Out Loss
Fencing with Gate for Secure Parking	15,000	0.04	570	0.06%	Acceptable
Total Site Work	1,532,750	4.28	58,255	6.09%	Acceptable
Building Excavation, Stone for Fill	263,000	0.73	N/A	1.04%	OK-Bought Out
Building Concrete	1,841,000	5.14	N/A	7.31%	OK-Bought Out
Precast Concrete	800,000	2.23	N/A	3.18%	Low/OK-Bought Out
Caulking of Precast and Windows	70,000	0.20	N/A	0.28%	Acceptable
Masonry	20,000	0.06	N/A	0.08%	Acceptable
Structural Steel and Metal Decking	2,585,000	7.22	N/A	10.26%	Low/OK-Bought Out
Utility Court Steel Doors	10,000	0.03	N/A	0.04%	Acceptable
Steel Stairs and Misc. Metals	300,000	0.84	N/A	1.19%	OK-Bought Out
Steel Precast Support at Tall Entries	50,000	0.14	N/A	0.20%	Unknown Scope
Spray on Fireproofing	362,000	1.01	N/A	1.44%	Acceptable
Foundation and Basement Waterproofing	35,000	0.10	N/A	0.14%	Acceptable
Misc. and Sanitary Caulking	9,150	0.03	N/A	0.04%	Acceptable
Metal Penthouse Siding and Louvers	255,100	0.71	N/A	1.01%	Seems High
60 Mil EPDM Roofing	249,432	0.70	N/A	0.99%	Acceptable
Windows, Entrances, Glass and Glazing	864,000	2.41	N/A	3.43%	OK-Bought Out
Mirrors	5,000	0.01	N/A	0.02%	OK-Bought Out
Overhead Dock Doors	10,000	0.03	N/A	0.04%	Acceptable
Drywall and Metal Studs	1,433,583	4.00	N/A	5.69%	Acceptable
Acoustical Ceilings	469,063	1.31	N/A	1.86%	Acceptable
Carpeting	470,000	1.31	N/A	1.87%	Seems Low
Lobby Floors Allowance	42,000	0.12	N/A	0.17%	Allowance
Ceramic Floor and Wall tile	75,000	0.21	N/A	0.30%	Seems low
VCT	90,000	0.25	N/A	0.36%	Acceptable
High Pressure P-Lam Flooring	25,000	0.07	N/A	0.10%	Acceptable
Painting and Vinyl Wall Covering	360,000	1.01	N/A	1.43%	Acceptable
Toilet Partitions	30,000	0.08	N/A	0.12%	Seems Low
Flag Pole	3,500	0.01	N/A	0.01%	Acceptable
Install Interior Signage	10,000	0.03	N/A	0.04%	Acceptable
Fire Extinguishers and Cabinets Allowance	20,000	0.06	N/A	0.08%	Allowance
Dock Equipment	15,000	0.04	N/A	0.06%	Acceptable
Access Flooring	145,000	0.41	N/A	0.58%	Acceptable
Window Blinds and Draperies	64,000	0.18	N/A	0.25%	Unknown Scope
Operable Walls	70,000	0.20	N/A	0.28%	Acceptable
Carpentry	124,500	0.35	N/A	0.49%	Acceptable
P-Lam Vanity Tops	24,000	0.07	N/A	0.10%	Acceptable
Hollow Metal Doors & Frames Allowance	79,000	0.22	N/A	0.31%	Allowance
Wood Doors Allowance	86,000	0.24	N/A	0.34%	Allowance
Hardware Allowance	149,500	0.42	N/A	0.59%	Allowance
Lobby Features Allowance	20,000	0.06	N/A	0.08%	Allowance
Toilet Accessories	35,957	0.10	N/A	0.14%	Acceptable
Building Directory and Floor Directories	7,500	0.02	N/A	0.03%	Acceptable
Misc. Counter Tops	500	0.00	N/A	0.00%	Unknown Scope
Closet Shelves and Rods	1,500	0.00	N/A	0.01%	Acceptable
Chair Rail	500	0.00	N/A	0.00%	Acceptable
T.V. Brackets	500	0.00	N/A	0.00%	Acceptable
Sound Absorbing Wall Panels	35,000	0.10	N/A	0.14%	Acceptable
NovaWall Wall System	21,000	0.06	N/A	0.08%	Unknown Scope
Elevators	795,000	2.22	N/A	3.16%	Acceptable
Plumbing	865,000	2.42	N/A	3.43%	OK-Bought Out
Fire Protection (no fire pump)	392,000	1.09	N/A	1.56%	OK-Bought Out
HVAC	3,310,000	9.25	N/A	13.14%	OK-Bought Out
Electrical	3,555,750	9.93	N/A	14.12%	OK-Bought Out
Total Building	20,554,035	57.41	N/A	81.61%	Compares Low
Total Trade Costs Site and Building	22,086,785	61.69	N/A	87.69%	Compares Low
General Conditions	1,618,000	4.52	N/A	6.42%	Acceptable
General Liability Insurance	150,215	0.42	N/A	0.60%	Acceptable
Subcontractor Bond Costs	221,000	0.62	N/A	0.88%	Acceptable
G/C's Fee	710,000	1.98	N/A	2.82%	Acceptable
G/C's Construction Contingency	400,000	1.12	N/A	1.59%	Acceptable
Total General	3,099,215	8.66	N/A	12.31%	Acceptable
Total Direct Cost Budget	25,186,000	70.35	N/A	100.00%	Needs Borrower Contingency

Figure 12.9 A project budget review for an office building has a total building area of 358,000 square feet and a total cost budget of \$25,286,000. It is interesting to note the various line item comments in the end column.

team should have specific procedures and protocols in place for issuance of instructions and information that ensure that any issued instructions are within the assigned authority and that before being issued, the cost of proposed change orders should be properly estimated and their impact fully evaluated. Any issued change order instruction should be fully sustainable in terms of value for money and overall positive impact on the project. Furthermore, adequate and continuous monitoring of the total costs of all issued instructions is necessary and where costs are determined to be outside the delegated authority, specific approval is required.

With respect to payments, this is discussed in [Chapter 4](#). Normally the client, as the contracting party is legally obligated to making all payments to the integrated project team including the interim and final payments as per the contract. These payments usually take the form of payments made at various stages of the work in progress or upon application for payment by the general contractor (usually at monthly intervals) upon inspecting and assessing the value of work in place. The client's lender (e.g., a bank) should be updated constantly on the project's progress—whether satisfactory or otherwise, by means of regular reports, memos, and cash flow and budget forecasts.

It should be noted that some lenders have a policy of not permitting funding for mobilization, only for actual work in place, while others do permit funding for certain trades. For this reason, the terms of the contract should be verified prior to commencement of the construction process. The contract may also include clauses that allow the project manager in certain circumstances to claim additional payments as specified in the contract's general conditions. Any justification for additional payment claims may be the result of or caused by occurring risks that are essentially considered to be client risks under the contract, requesting a change in scope or additional work, or by the client's failure to comply with its contract obligations which may be caused by a disruption to the project's scheduled program because of modifications, delivery delays, and the like.



Green Specifications and Documentation



13.1 GENERAL—OVERVIEW

Working drawings and specifications are the primary working documents used by a contractor to bid and execute a project. Specifications are the written documents that go with the construction documents and describe the materials as well as the installation methods. They consist of precisely written documentation that describes a project to be constructed, supplementing drawings and forming part of the contract and describing qualities of materials, their methods of manufacture and installation into the project, workmanship and mode of construction, in addition to providing other information not shown in the drawings including description of the final result. Many designers have considerable difficulty preparing a competent set of standard building specifications, partly because it demands a shift of gears by having to use a different medium to express design content—using written documents instead of drawing. It also propels the designer into the technical realm of materials that are not normally dealt with on a daily basis and which the designer may not be up to speed on.

Specifications should complement the drawings, not overlap or duplicate information in the drawings, and normally prescribe the quality standards of construction expected on the project. Specifications indicate the procedure by means of which it may be determined whether the requirements given are satisfied. Because specifications are an integral part of the contract documents, they are considered to be legal documents, and should therefore be comprehensive, accurate, and clear. Specification writing has two principal objectives: (1) defining the scope of work and (2) acting as a set of instructions. Defining the scope of work is at the core of specification writing. The required level of quality of the product and services must be clearly communicated to bidders and the party executing the contract and ensuring that the completed project conforms to this specified quality. Projects now generally incorporate the specifications within a project manual that is issued as part of the contract documents package along with the

drawings, bidding requirements, and other contract conditions. The specification writer should ensure that the requirements are compatible with the methods that are to be employed and also that the methods selected in one specification are compatible with those selected in another.

A primary function of project specifications is to give detailed information regarding materials and methods of work for a particular construction project. They cover various components relating to the project, including general conditions, scope of work, quality of materials, and standards of workmanship. The drawings, collectively with the project specifications, define the project in detail and clearly delineate exactly how it is to be constructed. The project drawings and specifications are an integral part of the contract documents and are inseparable. The drawings reflect what the project specifications are unlikely to cover; and the project specifications indicate what the drawings are unlikely to portray. Specifications are also sometimes used to further clarify details that are not adequately covered by the drawings and notes on the drawings. Project specifications will always take precedence over the drawings, should the information on the drawings conflict with that in the project specifications.

The Construction Specifications Institute's (CSI) MasterFormat is the most widely used standard for organizing specifications for building projects in the United States and Canada. The CSI has established a widely recognized format of organization for the technical specifications. CSI is a nationwide organization composed of different segments related to the construction industry such as architects, engineers, manufacturers' representatives, contractors, and other interested parties and have closely collaborated to develop this system of identification. These specification standards are noted in the MasterFormat which in 2004, which was expanded from 16 to 50 divisions as is described later in this chapter. It should be noted that the previous 1995 edition of the format is no longer supported by CSI. Also, note that the MasterFormat 2011 Update which is produced jointly by the CSI and Construction Specifications Canada (CSC), replaces all previous editions.

In recent years, we have witnessed a fundamental change in specification writing due to Technology and green-related practices which have had a tremendous impact on the construction industry and on the general way we conduct our business and to which specification writing has been radically affected. Examples of this are specification production and reproduction which in a few short years has witnessed tremendous progress due to these new technologies. Master systems are now commercially available in

electronic form allowing a specifier to simply load the master system into the computer and gets instant access to the master system, complete with drawing checklist and explanation sheets. Upon editing the relevant sections, a printout can be made with an audit trail that informs and records what has been deleted and what decisions remain undetermined. The CSI further comments that “Construction projects use many different kinds of delivery methods, products, and installation methods, but one thing is common to all – the need for effective teamwork by the many parties involved to ensure the correct and timely completion of work. The successful completion of projects requires effective communication amongst the people involved, and that in turn requires easy access to essential project information. Efficient information retrieval is only possible when a standard filing system is used by everyone. MasterFormat provides such a standard filing and retrieval scheme that can be used throughout the construction industry.”

Green building specifications can be easily incorporated into CSI *MasterFormat* in three general ways: (1) Environmental Protection Procedures, (2) Implementing Green Building Materials, and (3) Practical Application of Environmental Specifications.

It is also worth noting that on February 26, 2016, the Council on Environmental Quality issued the 2016 version of the Guiding Principles for Sustainable Federal Buildings with the intent to reflect the evolution of sustainable building design, and construction, along with the following documents: (1) Guiding Principles for Sustainable Federal Buildings and Associated Instructions. (2) Determining Compliance with the Guiding Principles for Sustainable Federal Buildings.

Understanding the updated version of the Guiding Principles is especially important since the federal government has over 500,000 facilities comprising more than 3 billion square feet including national park buildings, airport towers, federal courthouses, offices, hospitals, laboratories, defense facilities, and research facilities.



13.2 ARE SPECIFICATIONS NECESSARY?

The need for construction specifications is mainly because drawings alone typically fail to define the qualitative issues of a scheme. Specifications generally describe the materials and workmanship required for a development. They do not include cost, quantity, or drawn information, and so

need to be read alongside other information such as quantities, schedules, and drawings. Well-executed specifications form the written portion of the contract documents that are used to execute the project. Design decisions are continuously made as drawings develop from schematic sketches to detailed design to construction documents. Drawings are intended to depict the general configuration and layout of a design, including its size, shape, and dimensions. It informs the contractor of the quantities of materials needed, their placement, and their general relationship to each other. Technical specifications are a critical component of the contract documents as they reflect the design intent and describes in detail the quality and character of materials, as well as the standards to which the materials and their installation are required to conform, in addition to other issues that are more appropriately represented in written, rather than graphic form. The bottom line is that no matter how beautiful a designer's concept is, it is difficult to envisage the project being properly executed without clear, concise, accurate, and easily understood contract documents that include well-written specifications.

While it is true that construction drawings may contain all the information about a structure that can be presented graphically, it nevertheless omits information that the contractor must have but which is not adaptable to graphic presentation. Information in this category includes quality-related criteria for materials, specified standards of workmanship, prescribed construction methods, etc. In the event of a discrepancy existing between the drawings and the specifications, the specifications must be considered the final authority. For most projects the specification document will consist of a list of 50 divisions that usually starts with a section on general conditions. These are the rules of the job and provide the instructions for what to do in any of the anticipated situations on the project. The general conditions start with a general description of the building, including type of foundation, types of windows, character of framing, utilities to be installed, and so on. This is followed by definitions of terms used in the specs and then certain routine declarations of responsibility and other issues pertaining to the project.

Douglas D. Harding, a licensed California attorney, says that "Every project manager should be intimately aware of the general conditions to the project as part of his/her project administration effort." Furthermore, without an actual knowledge of the general conditions on each project, contractors and subcontractors are also taking an unacceptable risk that may ultimately cause ruin. In this respect Harding lists a number of important

general condition clauses that can directly impact the success of a project, if they are not given adequate attention or consideration:

- Progress Payments (when is it due? Is there a “condition precedent” clause?)
- Retention (How much and when is it due?)
- Change Orders (Overhead and profit; time extensions; inclusions)
- Delay (Notice and Time Impact Analysis)
- Scheduling (who has scheduling responsibilities? What kind of schedule is required? Is the subcontractor required to complete and maintain a schedule?)
- Order of Precedence (What is the order, do specs rule over drawings or do drawings rule over specs?)
- Notice (How many days after a delay to you have to give notice? How is notice to be delivered? verbally, by mail, by registered mail?)

It should be evident that even well-drawn construction drawings are unable to adequately reveal all the aspects of a construction project because there are many aspects that cannot be shown graphically. An example of this is trying to describe on a drawing the quality of workmanship required for the installation of electrical equipment or who bears responsibility for supplying the materials, except by extensive notes. For the majority of projects, the standard procedure then is to supplement construction drawings with written descriptions that define and limit the materials and fabrication according to the intent of the engineer or the designer. The specifications are therefore an important part of the project because they eliminate possible misinterpretation and ensure positive control of the construction.

Time and cost restraints tend to discourage individuals (or small firms) to venture to write a completely new set of specifications for each project that takes place. Because of this and other issues, specifiers often have to turn to alternative solutions. In this respect, the superiority and supremacy of using master systems over traditional specification writing is overwhelming. Moreover, because of liability issues, specifiers generally feel more comfortable relying on specifications that have repeatedly proven themselves in the past. Typical advantages of employing master systems include accuracy, the use of correct specification language and format for ease of specification preparation as well as the many sources, extensive product databases and reference material that is currently available and from which a complete set can be compiled for each new project. The master spec systems are also referred to when modification is implemented to fit the particular conditions of

a given job, or new specifications are incorporated. Master systems contain guide specifications for many materials which are constantly updated; this allows the specifier to edit out unnecessary text rather than generate new information for each project. In November of 2009, CSI launched GreenFormat, an online database organizing sustainable product attributes. GreenFormat says it “is a web-based CSI format that allows manufacturers to accurately report the sustainability properties of their products. It provides designers, constructors and building operators with basic information to help meet ‘green’ requirements.

Manufacturers report the attributes of their products through a comprehensive, online questionnaire. Their entries are then displayed through www.greenformat.com, where designers, constructors and building operators can search for products that fit their projects.”

Some of the more popular sources from which specification material can be acquired are listed below, much of which can be retrieved from the Internet and public libraries:

- Master specifications (Masterspec, SPECSsystem, MasterFormat, SpecText, Building Systems Design’s (BSD) Speclink, ezSPECS On-Line, 20–20 CAP Studio, and many others).
- Local and national codes and ordinances.
- Federal specifications (Specs-In-Tact, G.S.A., N.A.F.V.A.C., N.A.S.A.).
- National standards organizations such as the American National Standards Institute, National Institute of Building Sciences, the National Fire Protection Association, the National Institute of Standards and Technology, and the Association for Contract Textiles.
- Manufacturers’ industry associations (Fire Equipment Manufacturers’ Association, American Plywood Association, The Brick Industry Association, etc.).
- Testing societies (American Society for Testing and Materials, American Society for Nondestructive Testing, Underwriters Laboratories).
- Manufacturers’ catalogs (Sweet’s Catalog File, Man-U-Spec, Spec-data).
- Industry-related magazines and publications (Construction Specifier, Architecture, Green Magazine On-line, Interior Design, Architectural Lighting, Architectural Record).
- Books on relevant subjects.
- Information from files of previously written specifications.

Additionally, numerous firms providing online specification writing services have emerged during recent years. These services can easily be found on the Internet.



13.3 SPECIFICATIONS—TYPES AND CATEGORIES

In preparing a specification document, the specifier has to make an early determination in the process on which format or method is to be used to communicate the desired design intent to the contractor. Specifications vary considerably depending on the stage to which the design has been developed, ranging from basically two broad categories of specifications, performance specifications (open specifications) that require further design work to be carried out, to prescriptive specifications (closed specifications) where the design is already complete. Also, the advantage of having a prescriptive specification when a contract is tendered offers the client more certainty regarding the end product, whereas with a performance specification suppliers are given increased scope to innovate and adopt cost-effective methods of work, potentially offering better value for money. Within these two broad categories, there are four generic types of specifying construction products that are industry standards. These are:

1. Descriptive
2. Reference Standards
3. Performance
4. Proprietary

The type of specification chosen depends on several factors which are discussed below.

13.3.1 Closed or Prescriptive Specification

A closed (also called Restrictive) specification limits a product to a single manufacturer or a few brand-identified types or models and prohibits substitutions. This type of specification is more often used in the private sector in cases where specifiers feel more comfortable resorting to a specific proprietary product with which they are familiar, and which will meet the specific criteria of the project. However, it should be noted that this procedure (particularly when only one product is named) is not competitive, and rarely attracts the most favorable price for the owner. Also, while the closed specification is common in private construction work, it is generally prohibited by the Code for public projects and is required by law to be bid under open specifications. An open specification allows products of any manufacturer to be used if the product meets the specified requirements.

The closed proprietary specification method is considered the easiest form to write but the most restrictive in application, because it names a

specific manufacturer's product. It generally establishes a narrower definition of acceptable quality than do performance or reference standard methods, and gives the designer complete control over what is installed. The specification can also be transformed into an open proprietary specification in which multiple manufacturers or products are named or alternatives solicited by adding the phrase "or equal." This would increase potential competition and encourage a lower installation price from potential vendors. There are instances where a multiple choice may not be appropriate, as for example, in a renovation project where a specific brick is required for repairs to an existing brick facade.

1.3.3.2 Open or Performance Specifications

Also called Nonrestrictive, this type of specification gives the contractor some choice in how to achieve the desired results and is the type required by the Public Contract Code. Proprietary specifications may also be used as open specifications but with the addition of the "or equal" clause, which allows the contractor to consider other products for bid if they are shown to be equal in performance and specifications. Due to the ambiguity surrounding this clause, and the disagreements it often perpetuates, specifiers generally shy away from incorporating it into the **proprietary specifications**.

Descriptive Specifications

This is a method of open specifications that are gaining popularity and are sometimes referred to as prescriptive specifications. As the name implies, this type of specification describes in detail the requirements for the material or product and the workmanship required for its fabrication and installation without providing a trade name. Government agencies sometimes stipulate this type of specifications to allow greater competition among product manufacturers. Descriptive specifications are more difficult to write than proprietary ones because the specifier is required to include all the product's relevant physical characteristics in the specification bearing in mind the specifier has already decided that the specified product meets functional needs. For an individual product, proprietary, performance, and descriptive specifying techniques may be used.

Reference Standard

Reference standards specify standards such as ASTM, ASHRAE, State of California, Federal, etc. The various manufacturers must meet these standards. This standard basically describes a material, product, or process

referencing a recognized industry standard or test method as the basis for the specification and is often used to specify generic materials such as portland cement or clear glass. Thus, in specifying gypsum wallboard for example, the specification can state that all gypsum wallboard products shall meet the requirements of ASTM C36. It is worth mentioning that a number of construction industry members have voiced the opinion that specifications should not only make references to the applicable standards, but they should also quote the relevant parts of the referenced standards.

With the Reference Standard specification, the product is described in detail so that the specifier is relieved of the necessity to repeat the requirements but can instead refer to the recognized industry standard. In employing a reference standard, the specifier should not only possess a copy of that standard, but should also know what is required by the standard, including choices that may be contained therein, and which should be enforced by all suppliers. This type of specification is generally short and fairly straightforward and easy to write. In addition, the use of reference standard specifications reduces a firm's liability and the possibility for errors.

Performance Specifications

This type of specification has been developed over recent years for many types of construction operations. Rather than specifying the required construction process, performance specifications establish the performance requirements of the finished facility without dictating the methods by which the end results are to be achieved. The precise method by which this performance is obtained is left to the construction contractor. This gives the greatest latitude to contractors because it allows them to use any material or system that meets the required performance criteria, provided the results can be verified by measurement, tests, or other acceptable methods. Performance specifications are difficult to write; the specifier needs to know all the criteria for a product or system, determine an appropriate method for testing compliance, and write a clear and lucid document. This requires sufficient data to be provided to ensure that the product can be adequately demonstrated. Performance specifications are primarily used in cases where a specifier wants to inspire new ways of achieving a particular result in specifying complex systems.

Proprietary (Product) Specifications

This type of construction specification for a product often uses a combination of methods to convey the designer's intent. It is normally written by referencing

specific products by manufacturer and brand or model name and applies to materials and equipment. For example, a specification for a terra-cotta tile would use a proprietary specification to name the product or products selected by the specifier, a descriptive specification to specify the size and design, and a reference standard to specify the ASTM standard, grade, and type required. It is distinguished from prescriptive specifications in that the physical characteristics are inferred, rather than explicitly stated. For an individual product, proprietary, performance, and descriptive specifying techniques may be used. Proprietary specifications can be made “open” by adding the phrase “or equal.”



13.4 DEVELOPING THE PROJECT MANUAL

The CSI developed the first standard format for organizing construction information in 1963 and which later became known as *MasterFormat*. In 1964 the American Institute of Architects (AIA) developed the concept of the “Project Manual,” primarily to meet the pressing need for a consistent arrangement of building construction specifications. The Project Manual consists of an assemblage of documents related to the construction work on a project, and which is employed to guide the construction process. It typically includes bidding requirements (contract forms, bonds, certificates, etc.), sample documents, conditions of the contract, and the technical specifications which together with the drawings, constitute the contract documents. The project manual has gained general acceptance in the industry and is greatly preferred to the traditional method of organizing the project manual which was previously a matter of individual preference by the design firm producing them, resulting in a wide diversity of method around the country that became very confusing. As design firms and contractors became increasingly nationwide in their operations, the Project Manual continued to develop and while it may differ depending on the size and type of project, a typical project manual may include, but not be limited to:

- General Project information: This includes:
 - Title Page to include names and addresses of all parties responsible for the development of the project (owners, architects, civil engineers, mechanical engineers, electrical engineers, and structural engineers) in addition to a statement of compliance by the architect or engineer of record.
 - Table of Contents.
 - Schedule of Drawings.

- Bidding Requirements. This applies where contracts are awarded through the bidding process. These would include:
 - Invitation to Bid and Advertisement for Bids.
 - Instructions to Bidders, including Prequalification forms, Bid forms, Information available to bidders, date and time of bid opening and notice of pre-bid conference.
- Contract forms may include:
 - Sample Forms. *Include Public Entity Crime Form, Owner/Contractor Agreement, Performance and Payment Bond, Change Order, Bid Form which may require the general contractor's license number, may include a subcontractors list and license numbers, and other project forms.*
 - Bonding Requirements. Labor and Materials payment bonds are required on projects costing above a certain amount.
 - *Bid Security in the to be submitted in form of a certified check, cashier's check, treasurer's check, or bank draft of any national or state bank.*
 - *Performance Bond and Materials and Payment Bond. Each bond shall equal one hundred (100%) percent of the contract amount.*
 - Insurance Requirements:
 - *Worker's compensation and employer's liability.*
 - *Public liability to include personal injury, bodily injury, and property damage.*
 - *Products and completed operations liability.*
 - *Owner's protective liability.*
 - *Business automobile liability, including owned, nonowned, and hired automobiles.*
 - *Property all-risks coverage to one hundred (100%) percent of the value at risk, subject to acceptable deductibles.*
 - Contract Conditions: General conditions of the contract such as AIA Form 201 or similar preprinted forms. Supplementary conditions include anything that is not covered in the general conditions, such as addenda (changes made before contract signing), and change orders (changes made after contract signing). In addition, Contract Conditions include:

General Conditions and Supplementary Conditions including, but not limited to, the following:

 - *Deductive alternates must be used if bidding is to take place on a project where funds are in jeopardy of reversion and a rebid process would not be possible within remaining time available, and when the Client wants to preserve the option to negotiate with the apparent low bidder.*

- *Notice of time limit and method of payment to the contractor including final payment.*
 - *Time limit in which the construction is to be completed.*
 - *The penalty to be paid by the contractor for failure to comply with the time limits of the contract.*
 - *Federal wage rates and hourly scales shall be used where applicable. Federal wage rates are not required for construction projects financed totally from local or state funds.*
 - *A provision setting forth who should pay for standard tests of concrete, plumbing, electrical, steel, and others as required by industry standards.*
 - *The Client may include an incentive in the contract for early completion of the project.*
- **Technical specifications:** These provide written technical requirements concerning building materials, components, systems, and equipment shown on the Drawings with regard to standards, workmanship quality, performance of related services, and stipulated results to be achieved by application of construction methods (Fig. 13.1).

Being legal documents, the specification language must be written in a clear precise and unambiguous manner in order to communicate the intended concept. In this respect, a convention has developed over the years as to what specific information should be shown on the drawings and what should more appropriately be included in the specifications. Drawings should depict information that can be most aptly and effectively expressed graphically by means of drawings and diagrams. This would include relevant information such as dimensions, sizes, proportions, gauges, arrangements, locations, and interrelationships. Additionally, drawings are used to express quantity, whereas specifications normally describe quality. Also, drawings would denote type (e.g., wood), whereas specifications will clarify the species (e.g., oak). Well-written specifications on the other hand are essentially based on a number of broad general principles as outlined below:

- Specifications should only transmit information that lends itself to the written word, such as standards, descriptions, procedures, guarantees, and names.
- Specifications should be clear, concise, and technically correct.
- Specifications should avoid the use of ambiguous words that could lead to misinterpretation.
- Specifications should be written using simple words in short, easy-to-understand sentences.

MASTERSPEC SMALL PROJECT 2005

COMBINED TABLE OF CONTENTS - MASTERFORMAT 2004 (Section Text Only)

© 2005 The American Institute of Architects

Issue Date	Sect. No.	SECTION TITLE	SECTION DESCRIPTION
DIVISION 01 - GENERAL REQUIREMENTS			
2003	011000	SUMMARY	Summary of the Work, Owner-furnished products, use of premises, and work restrictions.
2003	012000	PRICE AND PAYMENT PROCEDURES	Allowances, alternates, unit prices, contract modification procedures, and payment procedures.
2005	013000	ADMINISTRATIVE REQUIREMENTS	Project management and coordination, submittal procedures, delegated design, and Contractor's construction schedule.
2003	014000	QUALITY REQUIREMENTS	Testing and inspecting procedures.
2005	014200	REFERENCES	Abbreviations, acronyms, and trade names referenced in MASTERSPEC SMALL PROJECT.
2003	015000	TEMPORARY FACILITIES AND CONTROLS	Temporary utilities and facilities for support, security, and protection.
2003	016000	PRODUCT REQUIREMENTS	Product selection and handling and product substitutions.
2003	017000	EXECUTION AND CLOSEOUT REQUIREMENTS	Examination and preparation, cutting and patching, installation, and closeout requirements.
DIVISION 02 - EXISTING CONDITIONS			
2003	024119	SELECTIVE STRUCTURE DEMOLITION	Demolition and removal of selected portions of buildings and site elements.
DIVISION 03 - CONCRETE			
2003	033000	CAST-IN-PLACE CONCRETE	General building and structural applications.
2005	033713	SHOTCRETE	Pneumatically projected mortar and concrete.
2005	034100	PRECAST STRUCTURAL CONCRETE	Conventional precast units.
2005	034500	PRECAST ARCHITECTURAL CONCRETE	Exposed surface units.
2003	034713	TILT-UP CONCRETE	Wall panels.
DIVISION 04 - MASONRY			
2003	042000	UNIT MASONRY	General applications, walls, partitions.
2005	042300	GLASS UNIT MASONRY	Glass block.
2005	044300	STONE MASONRY	Stone veneer laid in mortar.
2003	047200	CAST STONE MASONRY	Architectural units set in mortar.
DIVISION 05 - METALS			
2005	051200	STRUCTURAL STEEL FRAMING	Framing systems.
2005	052100	STEEL JOIST FRAMING	Standard SJI units.
2005	053100	STEEL DECKING	Roof, floor, composite types.
2005	054000	COLD-FORMED METAL FRAMING	Load-bearing and curtain-wall studs; floor, ceiling, and roof joists.
2003	055000	METAL FABRICATIONS	Iron, steel, stainless steel, and aluminum items (not sheet metal).
2003	055100	METAL STAIRS	Steel, with pan, abrasive-coated, and floor plate treads and tube railings.
2003	055200	METAL RAILINGS	Metal railings, including glass panels and wood rails.
DIVISION 06 - WOOD, PLASTICS, AND COMPOSITES			
2005	061000	ROUGH CARPENTRY	Framing, sheathing, subflooring, etc.
2005	061053	MISCELLANEOUS ROUGH CARPENTRY	Rough carpentry for minor applications.
2005	061600	SHEATHING	Wall and roof sheathing, subflooring, underlayment, and related products.
2005	061753	SHOP-FABRICATED WOOD TRUSSES	Metal-plate-connected members.
2003	061800	GLUED-LAMINATED CONSTRUCTION	Glued-laminated beams, arches, and columns.
2005	062000	FINISH CARPENTRY	Exterior and interior trim, siding, paneling, shelving, and stairs.
2005	064013	EXTERIOR ARCHITECTURAL WOODWORK	Trim, door frames, shutters, and ornamental items.
2005	064023	INTERIOR ARCHITECTURAL WOODWORK	Trim, custom cabinets, counter tops, flush paneling, and stairwork and rails.
2003	066113	CULTURED MARBLE FABRICATIONS	Vanity tops, shower walls, and tub surrounds.
DIVISION 07 - THERMAL AND MOISTURE PROTECTION			

MASTERSPEC SMALL PROJECT SPECIFICATIONS TABLE OF CONTENTS - COMBINED - Page 1 of 6

Figure 13.1 The MasterSpec Small Project 2005 Combined Table of Contents for a small project—MasterFormat 2004—section text only. *Source: American Institute of Architects.*

MASTERSPEC SMALL PROJECT 2005

COMBINED TABLE OF CONTENTS - MASTERFORMAT 2004 (Section Text Only)

© 2005 The American Institute of Architects

Issue Date	Sect. No.	SECTION TITLE	SECTION DESCRIPTION
2005	071113	BITUMINOUS DAMPPROOFING	Hot- and cold-applied dampproofing.
2005	071326	SELF-ADHERING SHEET WATERPROOFING	Self-adhering sheet types.
2005	072100	THERMAL INSULATION	Common building types, excluding roof.
2005	072419	WATER-DRAINAGE EXTERIOR INSULATION AND FINISH SYSTEM (EIFS)	Thincoat stucco over foam insulation.
2005	073113	ASPHALT SHINGLES	Both organic and fiberglass based.
2005	073129	WOOD SHINGLES AND SHAKES	Shingles and shakes for roofing and siding.
2005	073200	ROOF TILES	Clay and concrete units.
2005	074113	METAL ROOF PANELS	Factory-finished units, steel and aluminum, insulated and noninsulated.
2005	074213	METAL WALL PANELS	Factory-finished units, steel and aluminum, insulated and noninsulated, and liner panels.
2003	074600	SIDING	Aluminum, fiber-cement, and vinyl siding and soffit.
2005	075113	BUILT-UP ASPHALT ROOFING	Hot asphalt systems; insulation.
2005	075216	STYRENE-BUTADIENE-STYRENE (SBS) MODIFIED BITUMINOUS MEMBRANE ROOFING	Styrene-butadiene-styrene roofing systems; insulation.
2005	075323	ETHYLENE-PROPYLENE-DIENE-MONOMER (EPDM) ROOFING	Adhered, mechanically-fastened, and loosely-laid EPDM systems; insulation.
2005	076100	SHEET METAL ROOFING	Flat-seam, standing-seam, and batten-seam sheet metal roofing.
2005	076200	SHEET METAL FLASHING AND TRIM	Mostly for roofing systems.
2003	077100	ROOF SPECIALTIES	Copings, fasciae, gravel stops, gutters, and downspouts.
2003	077200	ROOF ACCESSORIES	Roof curbs, equipment supports, roof hatches, gravity ventilators, and ridge vents.
2005	078100	APPLIED FIREPROOFING	Concealed cementitious and sprayed fiber.
2003	078413	PENETRATION FIRESTOPPING	Through-penetration firestop systems.
2005	079200	JOINT SEALANTS	Elastomeric, latex, and acoustic sealants.
DIVISION 08 - OPENINGS			
2005	081113	HOLLOW METAL DOORS AND FRAMES	Standard steel doors and frames.
2005	081416	FLUSH WOOD DOORS	Wood-veneer, plastic-laminate, and hardboard-faced units.
2003	081423	CLAD WOOD DOORS	Solid-core and hollow-core units with stile-and-rail appearance.
2003	081433	STILE AND RAIL WOOD DOORS	Stock stile and rail units.
2005	083113	ACCESS DOORS AND FRAMES	Wall and ceiling units.
2005	083213	SLIDING ALUMINUM-FRAMED GLASS DOORS	Residential and commercial grades.
2005	083219	SLIDING WOOD-FRAMED GLASS DOORS	Residential and light-commercial grades.
2003	083323	OVERHEAD COILING DOORS	Steel, aluminum, and stainless steel curtains.
2005	083513	FOLDING DOORS	Accordion folding, panel folding, metal bifold, and bifold mirror doors.
2003	083613	SECTIONAL DOORS	Steel, aluminum, and wood and hardboard types.
2003	084113	ALUMINUM-FRAMED ENTRANCES AND STOREFRONTS	Standard systems including hardware.
2005	084433	SLOPED GLAZING ASSEMBLIES	Standard systems, mechanically or structural-sealant glazed.
2005	085113	ALUMINUM WINDOWS	Most standard types.
2005	085200	WOOD WINDOWS	Most standard types.
2005	085313	VINYL WINDOWS	Most standard types.
2003	086100	ROOF WINDOWS	Wood, aluminum, and vinyl flat-glass units.
2005	086200	UNIT SKYLIGHTS	Single- and double-dome acrylic and polycarbonate units.
2005	087100	DOOR HARDWARE	Hinges, locksets, latchsets, closers, stops, accessories, etc.
2003	087113	AUTOMATIC DOOR OPERATORS	Swinging and sliding types with controls.
2005	088000	GLAZING	General applications including mirror glass.
2005	089000	LOUVERS AND VENTS	Fixed, extruded-aluminum and formed-metal louvers; wall vents.
DIVISION 09 - FINISHES			
2005	092216	NON-STRUCTURAL METAL FRAMING	Non-structural metal furring and framing.
2005	092300	GYPSUM PLASTERING	Includes gypsum lath, metal lath, and gypsum plaster.

MASTERSPEC SMALL PROJECT SPECIFICATIONS TABLE OF CONTENTS - COMBINED - Page 2 of 6

Figure 13.1 cont'd.

MASTERSPEC SMALL PROJECT 2005

COMBINED TABLE OF CONTENTS - MASTERFORMAT 2004 (Section Text Only)

© 2005 The American Institute of Architects

Issue Date	Sect. No.	SECTION TITLE	SECTION DESCRIPTION
2005	092400	PORTLAND CEMENT PLASTERING	Includes metal lath and portland cement plaster.
2005	092613	GYPSUM VENEER PLASTERING	Includes gypsum base, cementitious backer units, and gypsum plaster.
2005	092713	GLASS-FIBER REINFORCED PLASTER (GFRP) FABRICATIONS	Fabricated units for interior use.
2005	092900	GYPSUM BOARD	Gypsum board, glass mat gypsum backing board, and cementitious backer units.
2005	093000	TILING	Typical installations; includes stone thresholds and cementitious backer units.
2003	093033	STONE TILING	Thin, modular, cut stone units; includes stone thresholds and cementitious backer units.
2005	095113	ACOUSTICAL PANEL CEILINGS	Mineral-base and glass-fiber-base panels with exposed suspension systems.
2005	095123	ACOUSTICAL TILE CEILINGS	Mineral-base tile with concealed suspension systems.
2005	096340	STONE FLOORING	Exterior and interior stone traffic surfaces.
2005	096400	WOOD FLOORING	Solid- and engineered-wood flooring.
2005	096513	RESILIENT BASE AND ACCESSORIES	Vinyl and rubber wall base, treads, nosings, and edgings.
2005	096516	RESILIENT SHEET FLOORING	Unbacked and backed sheet vinyl products, and linoleum sheet.
2005	096519	RESILIENT TILE FLOORING	Solid vinyl, rubber, vinyl composition, and linoleum floor tiles.
2005	096813	TILE CARPETING	Modular tile for commercial applications.
2005	096816	SHEET CARPETING	Direct glue-down and installations including cushion.
2005	097200	WALL COVERINGS	Vinyl wall coverings and wallpaper.
2005	097500	STONE FACING	Dimension stone wall facings, trim, and countertops.
2005	097723	FABRIC-WRAPPED PANELS	Decorative, tackable, and acoustic units.
2005	099100	PAINTING	Exterior and interior substrates; includes stained and transparent finished wood.
DIVISION 10 - SPECIALTIES			
2005	101400	SIGNAGE	Exterior and interior signs, letters, and plaques.
2005	101700	TELEPHONE SPECIALTIES	Telephone enclosures and directory storage units.
2005	102113	TOILET COMPARTMENTS	Color coated steel, stainless steel, plastic laminate, and solid-plastic types.
2005	102226	OPERABLE PARTITIONS	Acoustically rated, manually and electrically operated, flat-panel partitions.
2005	102600	WALL AND DOOR PROTECTION	Wall guards, hand rails, bed locators, corner guards, and wall covering.
2005	102800	TOILET, BATH, AND LAUNDRY ACCESSORIES	Standard commercial and residential units.
2003	103100	MANUFACTURED FIREPLACES	Fabricated metal units, wood-burning and gas, and accessories.
2005	104413	FIRE EXTINGUISHER CABINETS	Fire extinguisher cabinets including hose and valve cabinets.
2005	104416	FIRE EXTINGUISHERS	Fire extinguishers and mounting brackets.
2003	105143	WIRE MESH STORAGE LOCKERS	Fabricated storage units.
2003	105723	CLOSET AND UTILITY SHELVING	Coated wire units, fixed and adjustable.
DIVISION 11 - EQUIPMENT			
2005	112600	UNIT KITCHENS	Standard manufactured units.
2003	113100	RESIDENTIAL APPLIANCES	Kitchen and laundry appliances.
2003	115213	PROJECTION SCREENS	Front projection screens, manual and electrically operated units.
DIVISION 12 - FURNISHINGS			
2005	122113	HORIZONTAL LOUVER BLINDS	Manually operated blinds.
2005	122116	VERTICAL LOUVER BLINDS	Manually operated blinds.
2005	122200	CURTAINS AND DRAPES	Curtains and drapes including manual and motorized tracks.
2003	123530	RESIDENTIAL CASEWORK	Manufactured cabinets; plastic-laminate and solid-surface-material countertops.
2005	123640	STONE COUNTERTOPS	Granite, marble, serpentine, and slate countertops.

Figure 13.1 cont'd.

MASTERSPEC SMALL PROJECT 2005

COMBINED TABLE OF CONTENTS - MASTERFORMAT 2004 (Section Text Only)

© 2005 The American Institute of Architects

Issue Date	Sect. No.	SECTION TITLE	SECTION DESCRIPTION
2005	124813	ENTRANCE FLOOR MATS AND FRAMES	Recessed and surface-applied flexible floor mats and frames.
DIVISION 13 - SPECIAL CONSTRUCTION			
2005	132416	SAUNAS	Modular and precut saunas; includes heaters and accessories.
2005	133419	METAL BUILDING SYSTEMS	Systems consisting of structural framing, roofing and siding panels, and standard components.
DIVISION 14 - CONVEYING EQUIPMENT			
2005	142400	HYDRAULIC ELEVATORS	Preengineered hydraulic and roped-hydraulic units.
2005	142600	LIMITED-USE/LIMITED-APPLICATION ELEVATORS	Limited-use/limited-application elevators.
2005	144200	WHEELCHAIR LIFTS	Vertical and inclined types, and stairway chairlifts.
DIVISION 21 - FIRE SUPPRESSION			
2005	210500	COMMON WORK RESULTS FOR FIRE SUPPRESSION	Motors, hangers and supports, vibration isolation and seismic restraints, and meters and gages.
2003	211000	WATER-BASED FIRE-SUPPRESSION SYSTEMS	Wet-pipe sprinklers and standpipes.
DIVISION 22 - PLUMBING			
2005	220500	COMMON WORK RESULTS FOR PLUMBING	Motors, hangers and supports, vibration isolation and seismic restraints, and meters and gages.
2005	220523	GENERAL-DUTY VALVES FOR PLUMBING PIPING	Gate, globe, check, and ball valves.
2005	220700	PLUMBING INSULATION	Piping and equipment insulation.
2005	221113	FACILITY WATER DISTRIBUTION PIPING	Domestic and fire-protection water utility services outside the building.
2005	221116	DOMESTIC WATER PIPING	Potable-water piping and specialties inside the building.
2003	221123	DOMESTIC WATER PUMPS	Horizontal and vertical in-line pumps.
2003	221313	FACILITY SANITARY SEWERS	Sanitary sewerage and underground structures outside the building.
2005	221316	SANITARY WASTE AND VENT PIPING	Soil, waste, and vent piping and specialties inside the building.
2005	221353	FACILITY SEPTIC TANKS	Tank, distribution box, and drainage pipe.
2005	221413	FACILITY STORM DRAINAGE PIPING	Stormwater piping and specialties inside the building.
2003	221429	SUMP PUMPS	Wet-pit mounted, simplex packaged units and submersible sump pumps.
2003	223100	DOMESTIC WATER SOFTENERS	Fully-automatic, pressure-type, household water softener.
2005	224000	PLUMBING FIXTURES	Fixtures, carriers, faucets, and trim.
DIVISION 23 - HEATING VENTILATING AND AIR CONDITIONING			
2005	230500	COMMON WORK RESULTS FOR HVAC	Motors, hangers and supports, vibration isolation and seismic restraints, and meters and gages.
2005	230523	GENERAL-DUTY VALVES FOR HVAC PIPING	Gate, globe, check, and ball valves.
2003	230593	TESTING, ADJUSTING, AND BALANCING FOR HVAC	AABC and NEBB certified testing and balancing.
2005	230700	HVAC INSULATION	Pipe, duct, and equipment insulation.
2005	230900	INSTRUMENTATION AND CONTROL FOR HVAC	Electric/electronic controls and sequences for HVAC systems and equipment.
2005	231113	FACILITY FUEL-OIL PIPING	Piping, specialty valves, and transfer pumps.
2005	231123	FACILITY NATURAL-GAS PIPING	Natural-gas piping and specialties.
2005	231126	FACILITY LIQUEFIED-PETROLEUM GAS PIPING	LP-gas piping and specialties.
2005	232113	HYDRONIC PIPING	Heating and cooling water piping and condensate drain piping.
2003	232123	HYDRONIC PUMPS	Base mounted and inline; close coupled and separately coupled pumps.
2005	232300	REFRIGERANT PIPING	Piping, specialties, and refrigerant inside the building.
2003	233100	HVAC DUCTS AND CASINGS	Metal and fibrous ducts and accessories.
2005	233423	HVAC POWER VENTILATORS	Roof and wall mounted centrifugal fans, and ceiling-mounted and inline ventilators.
2003	233600	AIR TERMINAL UNITS	Fan-powered and shutoff, single-duct units.
2003	233713	DIFFUSERS, REGISTERS, AND GRILLES	Diffusers, registers, and grilles.
2005	235100	BREECHINGS, CHIMNEYS, AND STACKS	Gas vents, chimneys, and grease ducts.
2005	235213	ELECTRIC BOILERS	Electric, hot-water boilers.

Figure 13.1 cont'd.

MASTERSPEC SMALL PROJECT 2005

COMBINED TABLE OF CONTENTS - MASTERFORMAT 2004 (Section Text Only)

© 2005 The American Institute of Architects

Issue Date	Sect. No.	SECTION TITLE	SECTION DESCRIPTION
2005	235216	CONDENSING BOILERS	Pulse-combustion hot-water boilers.
2005	235223	CAST-IRON BOILERS	Gas- and oil-fired hot-water boilers.
2005	235400	FURNACES	Gas-, electric-, and oil-fired furnaces.
2003	236200	PACKAGED COMPRESSOR AND CONDENSER UNITS	Air-cooled units.
2005	236419	RECIPROCATING WATER CHILLERS	Packaged air-cooled units with factory mounted controls.
2005	236423	SCROLL WATER CHILLERS	Packaged air-cooled units with factory mounted controls.
2005	236500	COOLING TOWERS	Packaged, closed-circuit cooling towers.
2003	237333	INDOOR, INDIRECT-FUEL-FIRED HEATING AND VENTILATING UNITS	Packaged units with gas- and oil-fired furnace.
2003	237339	INDOOR, DIRECT GAS-FIRED HEATING AND VENTILATING UNITS	Packaged units; natural gas and propane fired.
2005	237413	PACKAGED, OUTDOOR, CENTRAL-STATION AIR-HANDLING UNITS	Packaged units with compressors, condensers, evaporator coils, fans, controls, filters, and dampers.
2003	238113	PACKAGED TERMINAL AIR-CONDITIONERS	Self-contained, through-the-wall terminal units with controls.
2005	238119	SELF-CONTAINED AIR-CONDITIONERS	Packaged cooling and heating units, with filters and controls; suitable for exposed installations.
2003	238146	WATER-SOURCE UNITARY HEAT PUMPS	Concealed and exposed console and rooftop heat-pump units.
2005	238219	FAN COIL UNITS	Heating and cooling, vertical and horizontal units.
2005	238229	RADIATORS	Hot water and electric baseboard units and convectors.
2005	238239	UNIT HEATERS	Hot water and electric, cabinet and propeller unit heaters.
2005	238316	RADIANT-HEATING HYDRONIC PIPING	Embedded pipe, fittings, specialties, and controls.
DIVISION 26 - ELECTRICAL			
2005	260500	COMMON WORK RESULTS FOR ELECTRICAL	Raceways, identification, supporting devices, and seismic controls.
2005	260923	LIGHTING CONTROL DEVICES	Modular dimming controls, time switches, photoelectric switches, occupancy sensors, and conductors and cables.
2005	260936	MODULAR DIMMING CONTROLS	Modular dimming controls.
2005	262200	LOW-VOLTAGE TRANSFORMERS	General purpose and specially dry type, 600 V and less.
2003	262413	SWITCHBOARDS	Front-connected, front-accessible switchboards, 600V and less, and TVSS and overcurrent protective devices.
2003	262416	PANELBOARDS	Lighting and appliance and distribution panel boards.
2003	262713	ELECTRICITY METERING	Energy and demand metering by utility.
2005	262726	WIRING DEVICES	Receptacles, switches, service fittings, and multioutlet assemblies.
2003	262813	FUSES	Cartridge type (600 V and less) and spare fuse cabinets.
2003	262816	ENCLOSED SWITCHES AND CIRCUIT BREAKERS	Fusible and nonfusible switches, molded-case circuit breakers, and enclosures.
2003	262913	ENCLOSED CONTROLLERS	Manual and magnetic controllers and enclosures.
2003	263533	POWER FACTOR CORRECTION EQUIPMENT	Capacitors for 600 V and less.
2005	264113	LIGHTNING PROTECTION FOR STRUCTURES	Roof- and stack-mounting air terminals and ground rods.
2003	264313	TRANSIENT-VOLTAGE SUPPRESSION FOR LOW-VOLTAGE ELECTRICAL POWER CIRCUITS	Service entrance and panelboard suppressors and enclosures for low-voltage power, control, and communication equipment.
2005	265000	LIGHTING	Exterior and interior luminaires, ballasts, exit signs, emergency lighting units, and lamps.
DIVISION 27 - COMMUNICATIONS			
2005	270500	COMMON WORK RESULTS FOR COMMUNICATIONS	Raceways, identification, supporting devices, and seismic controls.
2005	271013	RESIDENTIAL STRUCTURED CABLING	Communication system distribution devices, terminals, panels, raceways, and cables.
2005	271100	COMMUNICATIONS EQUIPMENT ROOM FITTINGS	Connections, backboards, hardware, and grounding.
2005	271500	COMMUNICATIONS HORIZONTAL CABLING	Unshielded twisted pair cable, outlets, and accessories.
DIVISION 28 - ELECTRONIC SAFETY AND SECURITY			
2005	280500	COMMON WORK RESULTS FOR ELECTRONIC SAFETY AND SECURITY	Raceways, identification, supporting devices, and seismic controls.

MASTERSPEC SMALL PROJECT 2005

COMBINED TABLE OF CONTENTS - MASTERFORMAT 2004 (Section Text Only)

© 2005 The American Institute of Architects

Issue Date	Sect. No.	SECTION TITLE	SECTION DESCRIPTION
2005	280513	CONDUCTORS AND CABLES FOR ELECTRONIC SAFETY AND SECURITY	Cabling, control wire and cable, optical fiber, and conductors.
2005	283100	FIRE DETECTION AND ALARM	Noncoded, zoned and addressable multiplex systems.
DIVISION 31 - EARTHWORK			
2003	311000	SITE CLEARING	Clearing and grubbing, and topsoil removal.
2003	312000	EARTH MOVING	Excavating, filling, and grading.
2003	313116	TERMITE CONTROL	Soil treatment, borate wood treatment, bait stations, and metal mesh barriers.
DIVISION 32 - EXTERIOR IMPROVEMENTS			
2005	321216	ASPHALT PAVING	Asphalt paving, pavement-marking paint, and concrete wheel stops.
2003	321313	CONCRETE PAVING	Concrete paving and pavement-marking paint.
2005	321400	UNIT PAVING	Brick, concrete, and rough-stone pavers in aggregate setting beds.
2003	323113	CHAIN-LINK FENCES AND GATES	Residential and commercial types.
2005	323223	SEGMENTAL RETAINING WALLS	Dry-laid concrete masonry unit walls.
2003	328400	PLANTING IRRIGATION	Piping, sprinklers, and controls.
2005	329200	TURF AND GRASSES	Seeded and sodded lawns.
2005	329300	PLANTS	Trees, shrubs, ground cover, and plants.
DIVISION 33 - UTILITIES			
2005	332100	WATER SUPPLY WELLS	Domestic water wells.
2003	334100	STORM UTILITY DRAINAGE PIPING	Piping and utility structures for gravity stormwater systems.
2005	334600	SUBDRAINAGE	Drainage piping, panels, and geotextiles.

- Specifications should use technically correct terms, and avoid slang or “field” words.
- Specifications should avoid fielding conflicting requirements.
- Specifications should avoid repeating requirements stated elsewhere in the Contract.

Confusion may result in some cases when there are exceptions to these understandings. For example, building departments of the majority of municipalities will only accept drawings with applications for building permits, and refuse to accept a project manual with specifications. Additionally, all data demonstrating building code compliance must be indicated on the drawings. However, the repetition of identical data on both the specifications and the drawings exposes the documents to potential errors and inconsistency. To achieve better communication, the specifier should:

- Avoid specifying standards that cannot be measured or phrases that are subject to wide interpretation.
- Avoid specifications that are impossible for the contractor to execute.
- Use clear, simple, direct statements, concise use of terms, and attention to grammar and punctuation. Avoid use of words or phrases that are ambiguous and imply a choice that may not be intended.
- Be impartial in designating responsibility. Avoid exculpatory clauses such as, “the General Contractor shall be totally responsible for all...,” which try to shift responsibility.
- Describe only one important idea per paragraph to make reading easier while facilitating comprehension, editing and modifying at a later date. Specifications to be kept as short and concise as possible, omitting words like *all*, *the*, *an*, and *a*.
- Capitalize the following: (1) the contract documents, such as Specifications, Working Drawings, Contract, Clause, Section, Supplementary Conditions; (2) major parties to the contract, such as Contractor, Client, Owner, Architect; (3) specific rooms within the building, such as Living Room, Kitchen, Office; (4) grade of materials, such as No. 1 Douglas Fir, FAS White Oak; and, of course, (5) all proper names.
- Avoid underlining anything in a specification, as this implies that the remaining material can be ignored.
- Ensure that the terms Shall and Will are used correctly. “Shall” designates a command: “The Contractor shall...” whereas “Will” implies choice: “The Owner or Architect will...”

It is imperative that the specifications and construction drawings are fully coordinated as they complement each other. Moreover, they should not contain conflicting requirements, errors, omissions, or duplications. Below is a summary of project manual requirements for a new construction project.

Summary—General Project Manual Requirements (to Be Edited as Required Based on Nature of the Project)

- List of contacts
- Location Map/Site Plan/Building Plans/Elevations (reduced scale)
- Borrowers Loan Agreement
- A/E Agreement (design Services)
- CM Agreement
- Construction Agreement
- Consultant Services Agreement
- Additional Service Billings
- Project Analysis Report
- Project Status Report Template
- Borrower's Draw Requests
- Construction Schedule
- GC/CM Applications for payment (current and log)
- Change Order/Pending Change Order Log
- Change Orders
- RFI Log
- Submittal Log
- Buyout/Subcontractor Log
- Vendor Log
- Allowances



13.5 SPECIFICATION ORGANIZATION AND FORMAT

Over the decades, many revisions and expansions to MasterFormat have occurred due to changes in the construction industry. The CSI and CSC originally created the 16-division MasterFormat in 1963. Today, this format is widely used both in the United States and Canada for preparing construction specifications concerning nonresidential building projects. MasterFormat has become the standard for titling and arranging construction project manuals containing bidding requirements, contracting requirements, and specifications. Since its inception the CSI struggled to try to

standardize the specification numbering system and the format of the Sections, which produced a modified MasterFormat in 1995.

During recent years, the CSI actively sought to further improve MasterFormat by adding new divisions to the system. In a concerted effort to address the rapidly evolving and growing computer and communications technology, a modified MasterFormat was introduced in 2004 which included a significant expansion and reorganization of the Project Manual Division numbers. In the new MasterFormat edition division numbers are increased from 16 to 50, of which 13 divisions are left blank to provide room for future revisions and to allow construction products and technology to evolve (Fig. 13.2). The revised numbering system allows for more than 100 times the number of subjects at the same level when compared to the old numbering system.

MasterFormat is a well-structured system employed by specifiers for organizing information into project manuals, for organizing cost data, for filing product information and other technical data, as well as for identifying drawing objects and presenting construction market data. The CSI describes it as a master list of numbers and titles for organizing information relating to construction requirements, products, and activities into a standard sequence. Although construction projects use a number of different delivery methods, products and installation, effective communication among the people involved on a project is crucial to achieve the successful completion of a project. MasterFormat facilitates standard filing and retrieval schemes throughout the construction industry, since without a standard filing system familiar to each user information retrieval would be almost impossible. This continuous effort to modify and enhance the MasterFormat is driven in part by the radical changes in the construction marketplace particularly with the development of new technologies.

The new MasterFormat standard provides a master list of divisions, and section numbers and titles within each division, to follow in organizing information about a facility's construction requirements and associated activities. Standardizing the presentation of information improves communication among all parties involved in construction projects. A full explanation of the titles used in MasterFormat is provided giving a general description of the coverage for each title. A keyword index of requirements, products, and activities is also provided to help users find appropriate numbers and titles for construction subjects. The current MasterFormat groups, subgroups, and divisions consist essentially of dividing the Specs into 50 Divisions. The newest MasterFormat's 2016 edition can be obtained via CSI's online bookstore at www.csinet.org. The MasterFormat 2004 Edition Divisions are:

PROCUREMENT AND CONTRACTING REQUIREMENTS GROUP:

- Division 00 — Procurement and Contracting Requirements

SPECIFICATIONS GROUP**General Requirements Subgroup**

- Division 01 — General Requirements

Facility Construction Subgroup

- Division 02 — Existing Conditions
- Division 03 — Concrete
- Division 04 — Masonry
- Division 05 — Metals
- Division 06 — Wood, Plastics, and Composites
- Division 07 — Thermal and Moisture Protection
- Division 08 — Openings
- Division 09 — Finishes
- Division 10 — Specialties
- Division 11 — Equipment
- Division 12 — Furnishings
- Division 13 — Special Construction
- Division 14 — Conveying Equipment
- Division 15 — RESERVED FOR FUTURE EXPANSION
- Division 16 — RESERVED FOR FUTURE EXPANSION
- Division 17 — RESERVED FOR FUTURE EXPANSION
- Division 18 — RESERVED FOR FUTURE EXPANSION
- Division 19 — RESERVED FOR FUTURE EXPANSION

Figure 13.2 The revised 2004 MasterFormat edition which has replaced the 1995 edition. *Source: Construction Specification Institute, Inc.*

Facility Services Subgroup:

- Division 20 — RESERVED FOR FUTURE EXPANSION
- Division 21 — Fire Suppression
- Division 22 — Plumbing
- Division 23 — Heating Ventilating and Air Conditioning
- Division 24 — RESERVED FOR FUTURE EXPANSION
- Division 25 — Integrated Automation
- Division 26 — Electrical
- Division 27 — Communications
- Division 28 — Electronic Safety and Security
- Division 29 — RESERVED FOR FUTURE EXPANSION

Site and Infrastructure Subgroup:

- Division 30 — RESERVED FOR FUTURE EXPANSION
- Division 31 — Earthwork
- Division 32 — Exterior Improvements
- Division 33 — Utilities
- Division 34 — Transportation
- Division 35 — Waterways and Marine Construction
- Division 36 — RESERVED FOR FUTURE EXPANSION
- Division 37 — RESERVED FOR FUTURE EXPANSION
- Division 38 — RESERVED FOR FUTURE EXPANSION
- Division 39 — RESERVED FOR FUTURE EXPANSION

Figure 13.2 cont'd.

Process Equipment Subgroup:

- Division 40 — Process Integration
- Division 41 — Material Processing and Handling Equipment
- Division 42 — Process Heating, Cooling, and Drying Equipment
- Division 43 — Process Gas and Liquid Handling, Purification and Storage Equipment
- Division 44 — Pollution Control Equipment
- Division 45 — Industry-Specific Manufacturing Equipment
- Division 46 — RESERVED FOR FUTURE EXPANSION
- Division 47 — RESERVED FOR FUTURE EXPANSION
- Division 48 — Electrical Power Generation
- Division 49 — RESERVED FOR FUTURE EXPANSION

Figure 13.2 cont'd.

It should be noted that CSI and CSC, through a joint MasterFormat Maintenance Task Team, continuously evaluate suggestions for revisions, and update the resource biannually. The newest edition (2016 edition) has been improved to be even more useful, although the vast majority of the resource have not changed. Nevertheless it is important to visit the CSI Website for latest updates (<http://www.csinet.org/masterformat>).

13.5.1 Specification Section Format

This provides a uniform standard for arranging specification text in a project manual's sections using a three-part format, and reduces the probability of omissions or duplications in a specification section. According to the CSI, "Rather than grouping administrative, product requirements and execution requirements under each product separately, *SectionFormat* provides a uniform approach to organizing specification text within each section. *SectionFormat* is based upon the principle that a section should be organized by grouping the administrative requirements, product requirements, and execution requirements for each product together." Thus each Specification Section covers a particular trade or subtrade (e.g., drywall, carpet, ceiling tiles). Furthermore, each Section is divided into three basic parts, each of which contains the specifications about a particular aspect of each trade or subtrade (Fig. 13.3). The updates are intended to reflect

Product Specification

Franchise: Hilton
Brand: Hilton Garden Inn

Project: Evolution '05 Prototype
Location: N/A

Item Code: CA-11 Guestrooms
Item: Guestroom

Issue Date: 07/22/2005
Print Date: 08/25/2006

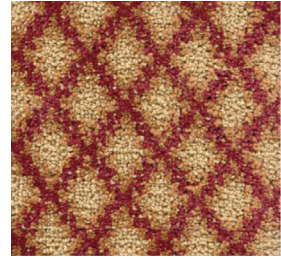

Description: Enhanced loop - tip sheer
Pattern Name: Custom
Color: Custom
Pat Design No Custom **Aprvd Strike-Off No:** M45104
Dr No: N/A **Reference No** N/A

Dimensions

Carpet Width: 12 ft 0 in
Prtn Repeat: Width: N/A Length: N/A

Specs

Contents: 100% solution dyed nylon
Dye Method: Solution dyed
Gauge: 1/10 **Pile Height:** .250" **Oz Wt-SY:** 32 **Tot Oz Wt-SY:** 74.10

Prm Backing: Woven Polypropylene

Sec Backing: ActionBack

Carpet Pad Pad to be Hartex Super pad. Fiber: Polyester; Weight: 40 oz; Density: 8.8; Thickness: 0.25-0.375; Breaking Strength: MD 32 lbs, CMD 31 lbs, ASTM 2262; Sound Absorption: NAC .61 ASTM C423-77; Thermal conduct: 2.02 ASTM C518-76.

Installation: Stretch-in

Locations: Guestroom

Fire Safety: Material must meet NFPA-253 or ASTM E-648 as required by local and state fire codes for use in hotels and other public areas.

Notes:

1. Carpet installation shall comply with all carpet manufacturer standards.
2. Certification of compliance required verifying that carpet meets or exceeds all local and state fire codes.
3. Manufacturer to provide maintenance instructions to owner.

Special Notes: 1. Templeton approved strike-off number: 45104.
Quantity: Quantity to be verified by installer before purchasing.

Vendors:

Templeton Carpet, 1900 Willowdale Road NW, Dalton, GA, 30720
Ph: 706-275-8665 Fax: 706-275-0687
Contact: Kelly Barker, Templeton Carpet Ph: 281-807-7927 Fax: 281-807-7158

Figure 13.3 An example of a product specification, in this case a carpet for a Hilton Garden Inn hotel chosen for the guest bedrooms. The vendor is Templeton Carpet. *Source: Paradigm Design Group.*

changes in the industry related to advancements in information technology and electronic publishing.

CSI notes that “PageFormat offers a recommended arrangement of text on a specification page within a project manual, by providing a framework for consistently formatting and designating articles,

paragraphs and subparagraphs. It also includes guidance for page numbers and margins.” CSI states that recent updates to PageFormat focused on making documents easier to read without limiting specific technology or processing methods. The updated version offers greater freedom to use sophisticated publishing and electronic media techniques on a wider variety of display devices.

Part 1: General

This part of the specification outlines the general requirements for the section and describes the administrative, procedural, and temporary requirements unique to the section. Part 1 is an extension of subjects covered in Division 1 and amplifies information unique to the section. In general, it outlines quality control requirements, delivery and job conditions requirements, trades with which this section needs to be coordinated with, and specifies what submittals are required for review prior to ordering, fabricating, or installing material for that Section. It generally consists of the following:

1. *Description and Scope:* This Article should include administrative and procedural requirements specific to the Section. It should also specify the scope of the work and the interrelationships between work in this Section and the other sections. It should also include a list of important generic types of products, work, and specified requirements. In addition, it should include the following:
 - a. **Products Supplied but not installed:** List products that are only supplied under this Section but whose installation is specified in other sections.
 - b. **Products installed but not supplied:** List products that are only installed under this Section but furnished under other sections.
 - c. **Allowances:** List products and work included in the section that are covered by quantity allowances or cash allowances. Do not include cash amounts. Descriptions of items should be included in Part 2 or Part 3.
 - d. **Unit Prices:** Include statements relating to the products and work covered by unit prices and the method to be used for measuring the quantities.
 - e. **Measurement Procedures:** State the method to be used for measurement of quantities. Complete technical information for products and types of work should be specified in the appropriate articles of Part 2 and Part 3.

to be furnished as per the contract. Includes requests for specific types of product data and shop drawings for review as well as submittal of product samples and other relevant information, including warranties, test and field reports, environmental certifications, maintenance information, installation instructions and specifics for closeout submittals.

4. *Product Handling, Delivery, and Storage:* To furnish instructions for various activities to include:
 - a. *Packing, Shipping, Handling, and Unloading:* Specify requirements for packing, shipping, handling, and unloading that are pertinent to products, materials, equipment, and components specified in the section.
 - b. *Acceptance at Site:* Describe the conditions of acceptance of items at the project site. This normally applies to owner provided products.
 - c. *Storage and Protection:* Outline special measures including temperature control that is needed to prevent damage to specific products prior to application or installation.
 - d. *Waste Management and Disposal:* Affirm any special measures required to minimize waste and dispose of waste for specific products.
5. *Project and Site Conditions:* Determine physical or environmental conditions or criteria that are to be in place prior to installation, including temperature control, humidity, ventilation, and illumination required to achieve proper installation or application. Statements that reference documents where information may be found pertaining to such items as existing structures or geophysical reports. For example, all wall tiling should be completed prior to cabinet installation.
6. *Sequencing and Scheduling:* This is required where timing is critical and where tasks and/or scheduling need to be coordinated and follow a specific sequence.
7. *Maintenance:* List items to be supplied by the contractor to the owner for future maintenance and repair. Delineate provisions for maintenance services applicable to critical systems, equipment, and landscaping.
8. *Warranties:* Terms and conditions of special or warranty or bonds covering the conformance and performance of the work should be spelled out and the Owner should be provided with copies.
9. *System Startup, Owner's Instructions, Commissioning:* List applicable requirements to the startup of the various systems. Include requirements for the instruction of the owner's personnel in the operation of equipment

and systems. State requirements for Commissioning of applicable systems to ensure installation and operation are in full compliance with design criteria.

10. *System Description*: Describe performance or design requirements and functional requirements of a complete system. Limit descriptions to composite and operational properties to the extent necessary to link multiple components of a system together, and to interface with other systems.

Part 2: Products

This Section describes the materials, products, equipment, fabrications, components, mixes systems and assemblies being specified and that are required for incorporation into the project. This section also details the standards to which the materials or products must conform to so as to fulfill the specifications, and similar concerns. Materials and products are included with the quality level required. Included in the itemized subsections are:

1. *Manufacturers*: This Section is used when writing a proprietary specification, and will include a list approved manufacturers. The Section should be coordinated with the Product Options and Substitutions Section. Names of manufacturers may be supplemented by the addition of brand names, model numbers, or other product designations.
2. *Materials, Furnishings, and Equipment*: A list should be provided of materials to be used. If writing descriptive or performance specifications, detail the performance criteria for materials, furnishings, and equipment. Describe the function, operation, and other specific requirements of equipment. This article may be omitted and the materials included with the description of a particular manufactured unit, equipment, component, or accessory. Environmental concerns such as toxicity, recycled content, and recyclability can be addressed here.
3. *Manufactured Units*: Fully describe the complete manufactured unit, such as standard catalog items.
4. *Components*: Describe the specific components of a system, manufactured unit, or type of equipment.
5. *Accessories*: Describe requirements for secondary items that aid and assist specified primary products or are necessary for preparation or installation of those items. This Article should not include basic options available for manufactured units and equipment.
6. *Mixes*: This Section specifies the procedures and proportions of materials to be used when site mixing a particular product. This Article relates mainly to materials such as mortar and plaster.

7. *Fabrication*: Describe manufacturing, shop fabrication, shop assembly of equipment and components, and construction details should be given. Specify allowable variations from specified requirements.
8. *Finishes*: Describe shop or factory finishing here.
9. *Source Quality Control*: Indicate requirements for quality control at off-site fabrication plants.
 - a. *Tests, Inspection*: Describe tests and inspections of products that are required at the source, i.e., plant, factory, mill, or shop.
 - b. *Verification of Performance*: State requirements for procedures and methods for verification of performance or compliance with specified criteria before items leave the shop or plant.
10. *Existing Products*: Create list of characteristics of assemblies, components, products, or materials that much match existing work, including matching material, finish, style, or dimensions. Specify compatibility between new and existing in-place products.

Part 3: Execution

The Section describes the quality of work—the standards and requirements specified in the installation of the products and materials. Site-built assemblies and site-manufactured products and systems are included. This part of the Specification specifies basic on-site work and includes provisions for incorporating products in the project. It also describes the conditions under which the products are to be installed, the protection required, and the closeout and postinstallation cleaning and protection procedures. The subheadings in this Section include:

1. *Inspection*: Define what the Contractor is required to do, for example, to the subsurface, prior to installation. Sample wording may include, “the moisture content of the concrete should meet manufacturer’s specifications, prior to installation of the flooring material.”
2. *Preparation*: Specify actions required to prepare the surface, area, or site to incorporate the primary products of the section. Also stipulate the improvements to be made prior to installation, application, or erection of primary products. Describe protection methods for existing work.
3. *Installation, construction, and Performance*: The specific requirements for each finish should be specified, as well as the quality of work to be achieved and includes:
 - a. *Special Techniques*: Describe special procedures for incorporating products which may include spacings, patterns, or unique treatments.

- Should the “green” additions be placed throughout the body of the specs, or should it be all gathered into one place where everyone can see it and where it is easy to update over time?

There are many opinions regarding these questions and considerable merit to go around for each of the answers to them. There are also numerous articles on Green Specifications on the Internet and it would be prudent to research this. There are also several green organizations such as GreenFormat (a web-based CSI format). Below are comments that may be helpful in greening your project:

- Integrate the green specs into your conventional ones without necessarily putting a particular emphasis on them.
- Establish the purpose of going green in your general or introductory specs.
- Use a program of high-performance scopes of work that integrates the various trade contractors work with pre- and postwork checklists and performance-based verifications.
- Take advantage of available Green Specification software programs to generate your specs.

For some guidance on these early sections of your specs, see the GreenSpec “Introduction to Guideline Specifications.” According to BuildngGreen.com, “These guideline specifications are designed to be modified as needed for new development, retrofits, and maintenance. They are organized into three Division 01 sections:

- 01 81 09 Testing for Indoor Air Quality
- 01 81 13 Sustainable Design Requirements
- 01 91 00 General Commissioning Requirements

Together, these three sections provide an overview of sustainable design requirements that might be appropriate in a wide variety of projects. When these sections are used in actual project specifications, specific requirements must be inserted throughout the construction documents to ensure compliance with the sustainable design intent.”

In many specifications we find the phrase “or equivalent,” or “approved equal” as a substitute for the original product. This is particularly important in green specifications because of the large amount of misinformation and “greenwashing” that plagues the market. It is therefore important to be precise and very clear upon which attributes the determination of equivalency is based upon. Some of the many green attributes that could be important in a green product specification include—recycled-content, durability, reusability, emissions, biodegradability, etc. It will not be fair to the owner, the contractor, design

consultant, or the employees/occupants if it's not clear from the outset what will constitute a fair substitution.

The CSI offers the following sample outline to illustrate its three-part SectionFormat with respect to environmental specifications of products:

CSI Green Product Specification Outline

Part 1. General

1. Environmental Requirements

1. List applicable environmental standards, regulations, and requirements.
2. Include VOC requirements.
3. List recycled content requirements.
4. Identify reuse, recycling, and salvaging methods.
5. Reference Division 1 Environmental Procedures for Construction.
 - i) VOCs or chemicals to avoid.
 - ii) General environmental procedures.
 - iii) Reuse, recycling, or salvaging requirements.
 - iv) Healthful building maintenance.

Part 2. Products

2. Specific Environmental Product Attributes

1. Product contains no xxxx chemicals (list and identify).
2. Product contains xx percent recycled content:
 - i) Identify postindustrial recycled content.
 - ii) Identify postconsumer recycled content.
3. Product is recyclable after useful life.
4. Product is certified by an independent third party.
 - i) Recycled content.
 - ii) Sustainably harvested.
5. Product is durable (list warranty).
6. Product is moisture resistant (if applicable).
7. Include any other environmental attributes.

Part 3. Execution

3. Environmental Procedures

1. Address environmental installation of materials.
2. Include protection of materials.
3. Identify environmental methods of cleanup.
4. Include recycling of scrap during construction.
5. Reference Division 1 Environmental Procedures.

The primary purpose of sample specifications is basically to supplement rather than replace the standard specifications. Model green specs are designed to be edited, adapted, and incorporated into the standard specifications of building projects and generally augment standard specifications by providing additional environmental information, such as Sustainable Building criteria, definitions, and performance requirements.



13.7 COMPUTERIZED SPECIFICATION WRITING SYSTEMS

Computer technology has been evolving at an unusually rapid pace in recent years, which may be why the era of manually prepared building specifications finds itself rapidly disappearing into the annals of history. Indeed, over the past decade, a number of firms have emerged that have developed various versions of automated specification writing systems and many now offer these services online to architects, interior designers, engineers, and others. And while computer-aided drafting (CAD) has revolutionized the drawing process, many architects and designers no longer possess the knowledge, expertise, or interest to write specifications for their projects. Computer software has reduced the need for some of the traditional skills shaped by years of experience writing construction specifications. Computer resources offer practitioners greater efficiency and the ability to deal with continually expanding compilations of information and provide almost immediate access to information from thousands of applicable electronic databases. This is coupled with an increasingly complex construction industry, changing methods of procurement, and the tremendous pressure on architects and designers to prepare contract documentation, including the specifications of the highest quality and in less time. This is further complicated by the fact that the complexity of new commercial construction requires continually updated knowledge, particularly with the adoption of new “green” codes (e.g., The International Green Construction Codes) and more eco-friendly products. With the changing nature of the industry and its new energy-efficient products, laws, environmental regulations, techniques for assembling products, and building industry practices cannot be adequately presented in educational courses for engineers and architects. Specialists are therefore urgently needed to manage and update information gathered from the many new products and innovations in the construction industry.

Today, there are an increasing number of automated CAD specification packages on the market. Of the better known firms is BSD SpecLink. This is

an automated master guide and specification management system for production of specifications, with built-in intelligence designed to help you significantly speed up editing tasks and reduce specification production time while minimizing errors and omissions. Combined with the industry's most comprehensive and up-to-date master database, SpecLink enables you to accelerate your specification development with tremendous accuracy and integrity.

The software system includes specification sections designed for use in construction documents, short form specifications, and design criteria documents. Furthermore, with SpecLink images can now be inserted into the text of up to 100K in size, from any of the following formats: Windows bitmap (.bmp), Windows metafile (.wmf), Portable Network Graphics (.png), JPEG File Interchange Format (.jpg,.jpeg), or Graphics Interchange Format (.gif). Hyperlinks can also now be inserted to Websites into the text. SpecLink uses master guide specifications in CSI 3-part format, and contains a database of over 780 master specification sections and over 120,000 data links that automatically include related requirements and exclude incompatible options as you select specification text. BSD also developed the PerSpective early design performance specifications organized by CSI UniFormat, which is the industry's first commercially available database of performance-based specifications (Fig. 13.4).

Another well-known program is InterSpec LLC which uses a proprietary technology that provides construction document management solutions and services built on its patented e-SPECS specification management technology (Fig. 13.5). e-SPECS software automates the specification process by extracting the product and material requirements directly from the project drawings; it also connects a large database of building specifications to an electronic architectural drawing of the project. Furthermore, e-SPECS integrates directly with Autodesk's AutoCAD, AutoCAD Architecture, AutoCAD MEP, and all Revit based applications in addition to supporting all libraries of MasterSpec. Interspec also has a do-it-yourself program designed for architects and designers with small projects which can be very helpful for the small firm.

For architects and engineers who spend many hours on every project preparing construction specifications, e-SPECS software is a proprietary browser-based specification management system that saves time and money while ensuring that the specifications agree with the construction documents. With this system the designer can also access the specs through the Internet and make alterations as the specs are being written. Like other automated systems, e-Specs service will enable design professionals to increase their productivity

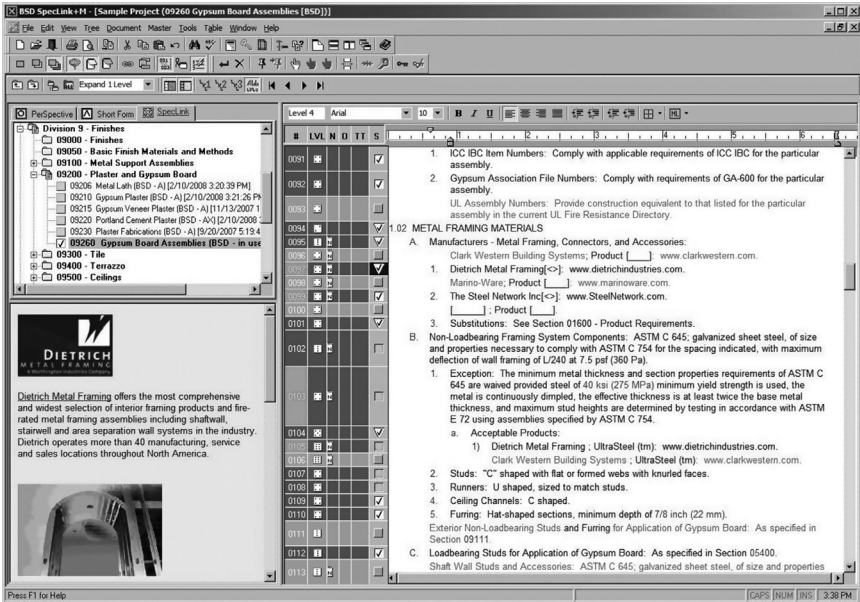

Figure 13.4 Building Systems Design's SpecLink Summary Catalog Listing and Computer Screen printout. SpecLink is one of the many electronic specification services that have emerged in recent years. Source: Building Systems Design, Inc.

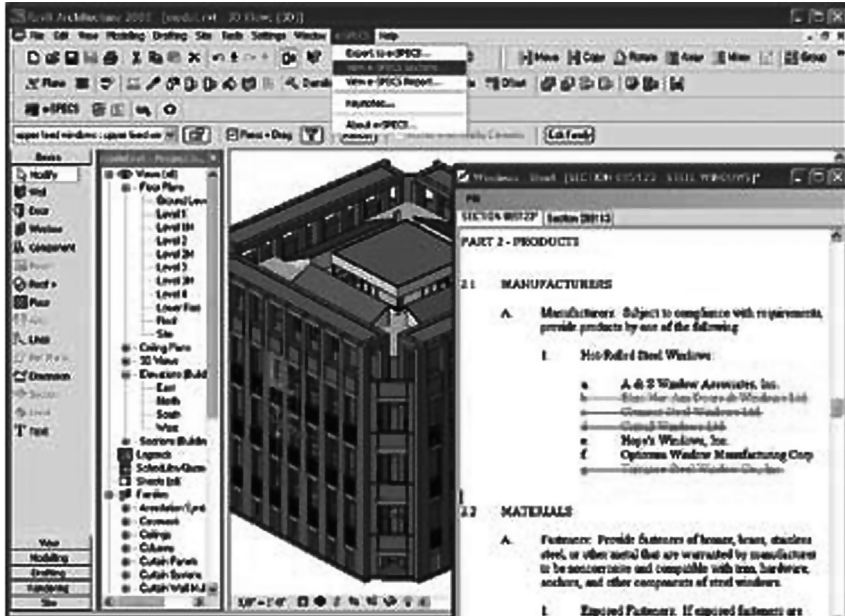

Figure 13.5 e-SPECS is an automated computer software system that integrates specifications with CAD and BIM applications. It can extract all the project requirements from the Revit model and allows direct access to the specs directly within Revit facilitating redlining and commenting in collaboration with the team members. Source: InterSpec, Inc.

while simultaneously reduce their costs. Also, by linking the architect's CAD drawings to the master guide specifications, there is no longer the need to mail or deliver large blueprint drawings to the spec writer. Moreover, with these automated systems, the designer can input all required information at the earliest phases of the project, before any drawings are even available, in addition to being able to almost instantly obtain an outline or preliminary specification of the project. InterSpec also announced a major upgrade to its e-SPECS specification management systems, and has recently released its Version 7.0 of e-SPECS which includes Revit Phase Support, Office Master Updater, and Enhanced Publishing Functionality. GreenWizard and InterSpec have formed Collaborative Partnership, and InterSpec says that future integrated tools from InterSpec and GreenWizard will help solve issues of green and LEED-oriented materials' specification, including product discovery and evaluation.

SpecsIntact System (Specifications-Kept-Intact) is another automated software system available for preparing standardized facility construction specifications used in facility construction projects worldwide. SpecsIntact was initially developed by the National Aeronautics and Space Administration (NASA) to assist architects, engineers, specification writers, project managers, construction managers, and other professionals doing business with the three government agencies using it, i.e., the NASA, the US Naval Facilities Engineering Command, and the US Army Corps of Engineers. According to its authors, the system provides quality assurance reports and automated functions that reduce the time required to complete project specifications. The Unified Facilities Guide Specifications Master that is employed by SpecsIntact are divided into functional Divisions according to the CSI format, with each Division containing related specification Sections. The principal elements within the Sections are annotated using SpecsIntact's application of the Extensible Markup Language. This tagging scheme provides the intelligence that SpecsIntact uses in automatically processing these Sections.

20-20 CAP Studio is an integrated package of applications that automate the design and specification process, and contains two base applications, 20-20 CAP Designer and 20-20 CAP Worksheet. CAP Designer is a CAD-based design tool operated within AutoCAD. CAP Worksheet is a power specification tool used for product pricing, specification, and estimating. The program has the ability to import complete large-scale space plans and layouts into CAP Worksheet for full specification, discounting, and order entry. The program specializes in furniture specification.

ARCOM recently announced its "revolutionary" Altarix product, a new productivity tool in its SpecWare suite of specification software. Its authors

claim that “Altarix is easy and intuitive to use, with a sleek interface that is more than just a document processor. Altarix provides standard functions like the ability to:

- Add, delete, and edit specification text
- Select options and automatically add punctuation
- Globally format all sections in a project
- Globally set headers and footers for a project

But Altarix goes beyond these basic capabilities and provides tools specially designed for specifiers, allowing them to:

- Add project notes and automatically track their status and resolution
- Insert specification sections into a project from another project
- Easily jump from one location in a specification section to another location
- Track completion progress for each specification section

Specifiers have complete control over their documents and can change the specifications as fast as clients change their mind.” Specifiers can also produce complete project manuals with the Altarix program.

This continuously evolving technology is transforming the way architects and interior designers prepare specifications for construction projects. The main advantages of automated systems are that they can provide greater accuracy, in less time, and at a lower cost. These systems also eliminate or minimize costly construction modifications caused by omissions, discrepancies, or improper quality controls. A firm’s proprietary interactive online editing systems can be integrated into the specification development process over the Internet with secure password access. A completed specification manual can readily be delivered online for client downloading, and easily be printed and bound, or presented on CD-ROM. For smaller design firms that lack necessary resources, outsourcing may be worth considering as the most effective way to proceed on a project.



13.8 LIABILITY ISSUES

There are several international associations in place to facilitate legal, technical, and political issues of international concern to the construction industry. All professionals including architects and engineers are expected to exercise reasonable care and skill in the implementation and execution of the various aspects of their work. The level of performance by professionals

should be consistent with that normally provided by other qualified practitioners under similar circumstances. However, this does not imply that projects will be executed to 100% perfection at all times, although the risk is now increased with the presence of “green” liability issues. In this respect, Advanced Control Corp. claims that “Many challenges facing risk managers and insurers in developing coverage for “green” construction projects are similar to traditional construction risks with just a few differences. The difference generally being new technology and materials, which are untested and often experimental, and can lead to unfounded expectations. Green construction focus has brought to the table a whole new set of problems regarding what kind of damages may arise from green building projects, all the way from how to define them in insurance policies to coverage of damages and the services provided.”

However, the law relating to professional responsibility and liability has in recent years become very active and has assumed unprecedented urgency; the parameters of risk and exposure have expanded dramatically in professional practice, so that under current law, if a professional designer enters into a contractual agreement and specifies a subsystem of a commercial or institutional space, he/she assumes responsibility for the satisfactory performance of that system. Another area that is emerging and that is causing significant concern is exposure relating to the liability of the professional designer to third parties who have no connection with the contract for claims of negligence or design errors that allegedly lead to injury of persons using the building. The legal bases for the majority of liability suits often overlap, but generally include professional negligence, breach of contract, implied warranty or misrepresentation, joint and several liability and liability without fault for design defects. Moreover, if designers fail to reject defective work by a contractor or supplier, they may now be considered to be professionally negligent and in breach of contract.

Product liability, i.e., building product performance is another area of exposure in which the architect is held responsible for damages caused by faulty materials and components and sometimes for the cost of their replacement. This additional burden places a heavy emphasis on the appropriate selection and specification of building products with long records of satisfactory performance, thus often discouraging the introduction of new materials (e.g., green products), and methods. Product liability is primarily concerned with negligence and is discussed in [Chapter 16](#). It especially affects manufacturers, retailers, wholesalers, and distributors. Furthermore, with the upsurge of green delivery systems, designers and specifiers are increasingly finding

themselves involved in product liability suits. The best way to minimize these product liability actions is by specifying products that are manufactured for the intended use and that have been adequately tested.

Finally, design professionals can more effectively protect themselves from potential liability suits by working within their area of expertise, using concise contracts and specifications, complying with codes and regulations, using reputable and licensed contractors, maintaining accurate records, maintaining legal counsel and ensuring that adequate and appropriate liability insurance is in place.



13.9 REFERENCED STANDARDS

- ASHRAE—American Society of Heating, Refrigerating and Air-Conditioning Engineers—www.ashrae.org
 - 62.1-2016: Ventilation for Acceptable Indoor Air Quality
 - 62.2-2016: Ventilation and Acceptable Indoor Air Quality in Low-Rise Residential Buildings
 - 90.1-2013: Energy Standard for Buildings Except Low-Rise Residential Buildings
 - 90.2-2007: Energy Efficient Design of Low-Rise Residential Buildings
 - 62.1-2007: Ventilation for Acceptable Indoor Air Quality
 - 90.1-2004: Energy Standard for Buildings Except Low-Rise Residential Buildings
 - 189.1-2014, Standard for the Design of High-Performance Green Buildings
- ASTM—American Society for Testing and Materials International—www.astm.org
 - C518-04—Test Method for Steady-State Thermal Transmission Properties by Means of the Heat Flow Meter Apparatus
 - C1371-04a—Standard Test Method for Determination of Emittance of Materials Near Room Temperature Using Portable Emissometers
 - C1549-04—Standard Test Method for Determination of Solar Reflectance Near Ambient Temperature Using a Portable Solar Reflectometer
 - D6400-04—Standard Specification for Compostable Plastics

- D6868-03—Standard Specification for Biodegradable Plastics Used as Coatings on Paper and Other Compostable Substrates
- D7081-05—Standard Specification for Non-Floating Biodegradable Plastics in the Marine Environment
- E408-71 (2008)—Standard Test Methods for Total Normal Emittance of Surfaces Using Inspection-Meter Techniques
- E1333-96—Test Method for Determining Formaldehyde Concentrations in Air and Emissions Rates from Wood Products Using a Large Chamber
- E1980-01—Standard Practice for Calculating Solar Reflectance Index of Horizontal and Low-Sloped Opaque Surfaces
- BIFMA—Business and Institutional Furniture Manufacturers Association—www.bifma.com
- CRI—Carpet and Rug Institute—www.carpet-rug.org
 - Green Label Plus Testing Program (Carpet and Carpet Adhesive)
 - Green Label Testing Program (Carpet Pad)
- CRRC—Cool Roof Rating Council—www.coolroofs.org
 - 1—Product Rating Program Manual
- CRS—Center for Resource Solutions—www.green-e.org
 - green-e Product Certification Requirements (for Renewable Energy)
- CSA—Canadian Standards Association—www.csa.ca
 - 2810: Life Cycle Impact Assessment: Pulp and Paper Production Phase
- EPAAct—Energy Policy Act (EPAAct) of 1992 (water fixture maximum flow rates)
- EPA—Environmental Protection Agency—www.epa.gov
 - Comprehensive Procurement Guide—www.epa.gov/oswer/non-hw/procure/products.htm
 - Energy Star Rating System—www.energystar.gov/products
 - National VOC Emission Standard—www.epa.gov/epp/pubs/env-lab/volatile.pdf
 - Priority PBT List—www.epa.gov/pbt/pubs/cheminfo.htm
 - Reference Test Method 24—Surface Coatings
- FSC—Forest Stewardship Council's Principles and Criteria—<http://www.fscus.org>
- GREENGUARD Environmental Institute—www.greenguard.org
- GREENGUARD Certification Standards for Low Emitting Products for the Indoor Environment

- GREENGUARD Product Emission Standard for Children and Schools
- Green Seal—www.greenseal.org
 - GC-03—Anti-Corrosive Paints—www.greenseal.org/certification/standards/anti-corrosivepaints.cfm
 - GC-09—Residential Central Air Conditioning Systems—www.greenseal.org/certification/standards/residential-ac-central.cfm
 - GC-12—Occupancy Sensors—www.greenseal.org/certification/standards/occupancysensors.cfm
 - GC-13—Split-Ductless Air-Source Heat Pumps (GC-13)—www.greenseal.org/certification/standards/splitductless_heat-pumps.cfm
 - GC-15—Residential Central Air Source Heat Pumps—www.greenseal.org/certification/standards/residential-ac-heatpumps.cfm
 - GS-05—Compact Fluorescent Lamps—www.greenseal.org/certification/standards/
 - GS-11—Paints—www.greenseal.org/certification/standards/paints.cfm
 - GS-13—Windows (GS-13)—www.greenseal.org/certification/standards/windows.cfm
 - GS-14—Window Films (GS-14)—www.greenseal.org/certification/standards/windowfilms.cfm
 - GS-31—Electric Chillers—www.greenseal.org/certification/standards/electricchillers.cfm
 - GS-32—Photovoltaic Modules—www.greenseal.org/certification/standards/
 - GS-36—Commercial Adhesives, October 19, 2000—www.green-seal.org/certification/standards/commercialadhesives.cfm
 - GS-37—Industrial and Institutional Cleaners: Green Seal Environmental Standard for General-Purpose, Bathroom, Glass, and Carpet Cleaners Used for Industrial and Institutional Purposes—www.greenseal.org/certification/standards/g37.pdf
 - GS-37 Standard, Edition 7.2
 - GS-40—Industrial and Institutional Floor Care Products: Finishes and Compatible Strippers Used for Industrial and Institutional Purposes—www.greenseal.org/certification/standards/g40.pdf
 - GS-43—Recycled-Content Latex Paint, August 1 2006
- IDA—International Dark-Sky Association—www.darksky.org/ida/ida_2/index.html

- ISO—International Organization for Standardization—www.iso.org
 - 14001:1996—Environmental Management Systems—Specification with Guidance for Use
 - 14021:1999—Environmental Labels and Declarations—Self-Declared Environmental Claims (Type II Environmental Labeling)
 - 14024:1999—Environmental Labels and Declarations—Type I Environmental Labeling - Principles and Procedures
 - 14025:2006—Environmental Labels and Declarations—Type III Environmental Declarations—Principles and Procedures
 - 14040:2006—Environmental Management—Life Cycle Assessment—Principles and Framework
 - 21930—Sustainability in Building Construction—Environmental Declaration of Building Products
- NFRC—National Fenestration Rating Council—www.nfrc.org
 - 100-04—Procedure for Determining Fenestration Product Thermal Properties
 - 200-04—Procedure for Determining Fenestration Product Solar Heat Gain Coefficients at Normal Incidence
 - 300-04—Procedures for Determining Solar Optical Properties of Simple Fenestration Products
 - 400-04—Procedure for Determining Fenestration Product Air Leakage
 - 500-04—Procedure for Determining Fenestration Product Condensation Resistance Values
- PEFC—Programme for the Endorsement of Forest Certification—www.pefc.org
- RFCI—Resilient Floor Covering Institute—www.rfci.com
- FloorScore—Testing program certified by SCS to comply with the VOC emissions criteria of the CA CHPS Section 01350 emissions standard—www.scscertified.com/iaq/floorscore.html
- SCS—Scientific Certification Systems—www.scscertified.com
- SFI—Sustainable Forestry Initiative—www.sfiprogram.org
- SGS—SGS Group—www.sgs.com
- NSF—National Science Foundation—www.nsf.gov
 - 140—Sustainable Carpet Assessment
- SmartWood—www.rainforest-alliance.org/programs/forestry/smartwood/
- Soil Association—www.soilassociation.org/forestry

- SCAQMD—South Coast Air Quality Management District—www.aqmd.gov/rules
 - South Coast Rule #1113, Architectural Coatings—www.aqmd.gov/rules
 - South Coast Rule #1168, October 3, 2003, Adhesive/Sealant VOC Limits (www.aqmd.gov/rules/reg/reg11/r1168.pdf), State of California
- CHPS—The Collaborative for High Performance Schools
- Section 01350—Special Environmental Requirements (emissions testing requirements)—www.ciwmb.ca.gov/greenbuilding/specs/
- OEHHA—Office of Environmental Health Hazard Assessment
- California Proposition 65 Chemicals—List of chemicals known by California EPA to cause cancer www.oehha.ca.gov/prop65/prop65_list/newlist.html
- UL—Underwriters Laboratories, Inc.
- USDA—US Department of Agriculture—www.biobased.oce.usda.gov/fb4p/
 - Bio-based Compliant Program
- US Energy Policy Act 1992—www.loc.gov



Types of Building Contract Agreements



14.1 INTRODUCTION

The most effective way to mitigate risk in a sustainable project is having a properly drafted contract. Today, there are several very good contracts in the marketplace. For example, the AIA released “sustainable project” versions of key AIA Contract Documents in 2012 which have been expanded and updated. Today, those AIA Sustainable Project Contract Documents are among the most popular in the industry. Another example of a popular contract document is the Associated General Contractors of America ConsensusDOCS “Green Building Addendum” where the parties designate a Green Building Facilitator (GBF) to coordinate or implement acknowledged goals, which can be a project contributor or consultant. This is discussed below. Also, in some cases the Owner or Lender may prefer to use their own contract. But whatever the case, this contract basically sets up the terms for the parties and outlines the role of the architect in the project. When the architect’s association drafts the AIA contract, it will most likely be more favorable to reflect the interests of architects compared to the other parties to the contract, which is why some Owners and Contractors consider the need for alternative contracts such as ConsensusDOCS or the EJCDC contract. Choosing the most appropriate type of contract that serves your purpose is important as the construction process is often governed by such complicated contracts that involve complex relationships in several tiers. Thus as indicated, there are many forms of Contracts, with some favoring the client, others the builder. But whatever the contract type, it should be taken seriously and carefully scrutinized. Contracts are usually categorized according to the type of payment but can be tailored to incorporate common elements from several different Contract types.

As just mentioned, one alternative to the AIA contracts are the ConsensusDOCS contracts which were developed by a group of construction industry organizations that represent the interests of building owners, contractors, and surety providers. Organizations that represent the interests of design

professionals did not play a major role in developing the ConsensusDOCS contracts. Furthermore, a ConsensusDOCS contract does not set any specific standards for the quality of work to be done by design professionals. Another difference between ConsensusDOCS and the AIA standards is that the role of the architect in the communication between the building owner and the contractor is reduced.

Another alternative contract is the EJCDC contract documents. The EJCDC has a suite of contracts relating to construction projects. Like the ConsensusDOCS, the EJCDC contracts also downplay the role of the architect in managing the project.

In addition to the above, it is of great importance in this industry for the contractor to know how to bid a construction job if there is any chance at ever turning a profit. In today's competitive marketplace, the most effect approach to bidding a construction job is to have an experienced estimator on hand who can utilize an estimating computer program to come up with the best (and lowest) possible cost. Construction bid software can be readily purchased by a general contractor and installed on the computers, or, increasingly, it can be web based. The use of construction bid software is no longer a luxury but has become an absolute necessity for successful bidding, and the benefits of its use are very substantial. The software programs can develop budgets and establish cost baselines, as well as allow general contractors to keep track of the financial status of a project on a daily or hourly basis as opposed to, far less frequently, when done manually by an employee. Furthermore, all budgetary information is stored in one location and is easily accessed as opposed to using the traditional filing system, and the likelihood of errors and omissions is far less than it would be if the computations were done by hand.



14.2 BIDDING PROCESS AND TYPES OF BUILDING CONTRACTS

Since each construction project is different, the project delivery system should be tailored to the individual requirements of that unique project. Typically the owner chooses the project delivery system that will be employed but may rely on the professional input of architect and construction consultants to determine which project delivery system will best fit the project. With public funded projects, the method of construction delivery may be specified by the local or state jurisdiction. Although there is no set way on how to bid construction jobs, a tried and true method is

developing the lowest bid based on an accurate cost estimate. It is obviously important to know how to bid construction jobs as it can often make the difference between success and bankruptcy for a construction contractor. Normally, construction bidding consists of submitting a proposal to carry out a described residential or commercial construction project for an agreed sum and within certain parameters (generally according to the contract documents). Bidding for a project can occur at the construction manager (CM), general contractor, or subcontractor level. Contractors can submit their bids for the total cost of a construction tender to the project owner, developer, or consultant. A decision can then be made to award the contract taking into account various factors such as price, contractor qualifications, time to complete the project, etc. Moreover, construction contracts need to be carefully drafted and managed to avoid possible exposure to financial penalties and turning a potentially profitable project into an unprofitable one. As for bidding on Federal projects, the Federal Acquisition Regulation (FAR) 28.102 stipulates that all construction projects over \$100,000 are subject to the Miller Act which requires performance and payment bonds. Performance bonds represent a promise of surety to the government that once the contract is awarded, the contractor will perform its obligations under the contract. But whether Federal or private, for the contract to be lucrative, it must minimize or eliminate risk factors as much as possible.

There are a number of project delivery systems, the most common methods of which are discussed in greater detail in [Chapter 3](#). The three primary delivery systems are:

- the traditional design-bid-build (DBB)—[Fig. 14.1](#)
- the design-build (DB)—[Fig. 14.2](#)
- the construction management (as advisor CM or at-risk CM)—[Fig. 14.3](#)

Each of these delivery systems have distinct advantages and disadvantages depending on the project in hand, and all can be used to successfully plan, design, and undertake a given construction project.

14.2.1 Design-Bid-Build

In Design/Bid/Build, also known as the general contracting project delivery method, the process is linear, where one phase is completed before another phase is begun with no overlap. This is the traditional method of project delivery and has been the most widely used construction delivery method since ancient times. It is also the one with which most Owners are familiar. Under the design/bid/build example, the architect is selected under a separate contract that is based on a negotiated professional fee.

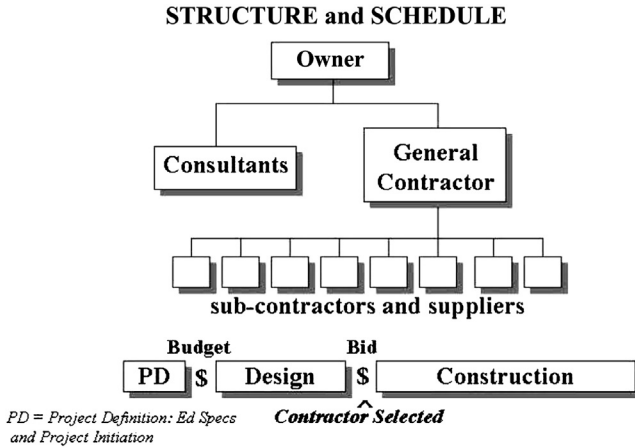

Figure 14.1 Diagram illustrating the structure and schedule of the traditional design-bid-build delivery system.

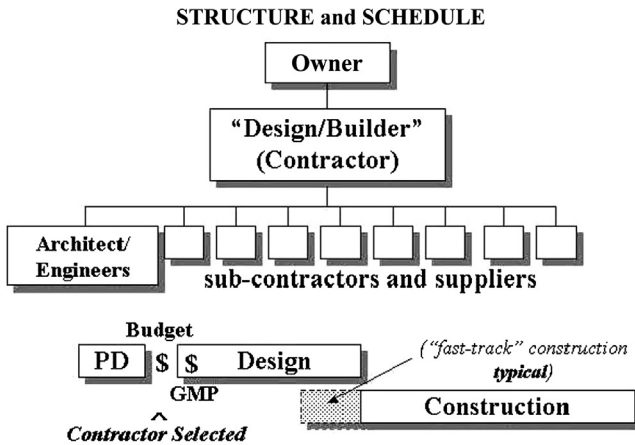

Figure 14.2 Diagram illustrating the structure and schedule of the design-build (DB) delivery system.

It therefore commences with an owner selecting an architect to prepare construction documents. Most often the architect will release these construction documents publicly, or to a select group of invited prequalified general contractors, who will be asked to bid on the project which reflects what they believe the total cost of construction will be. This bid is inclusive of various other bids from subcontractor for each specific trade. The general contractor's fee is generally built into the bid cost. The majority of government contracts are required to bid competitively using this method.

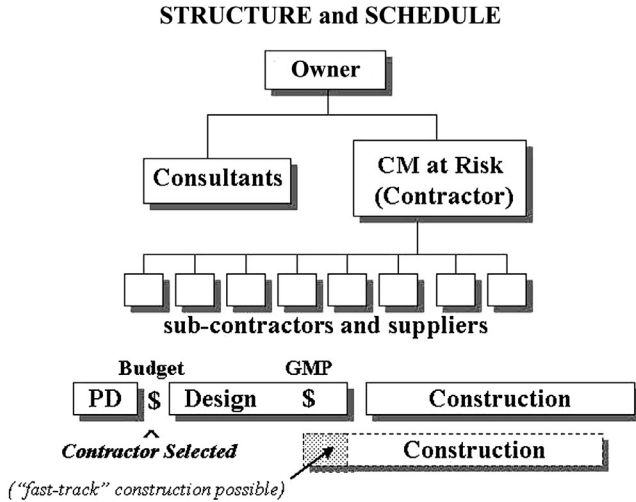

Figure 14.3 Diagram illustrating the structure and schedule of the construction manager (CM) at risk (at-risk CM) delivery system.

Contractors bid the project exactly as it is designed with the lowest responsible, responsive bidder awarded the work. The design consultant team is selected separately and reports directly to the owner. This type of contract is most suited for less complicated projects that are budget sensitive but not necessarily schedule sensitive and not subject to change. The Owner can define and control the design through the Architectural Consultant.

14.2.2 Design-Build

The trademark of a DB project is that a single entity, either the architect or the construction firm, is solely responsible to the owner for both design and construction of the facility. In the design/build project delivery method, a single point of contact has been proven to foster better communication, lessen confrontational roles between design and construction, and accelerate project delivery which is perhaps its biggest advantage. On this, Mark Cladny of *On Site Systems* opines, "The design/build approach has been touted as the contracting method of choice for the future, eliminating construction disputes and hastening the design and construction process." This may be so; the system essentially focuses on combining the design, permit, and construction schedules in a manner that allows the streamlining of the traditional DBB environment. A guaranteed maximum price (GMP) is typically provided by the DBer entity early in the project, based upon design criteria prepared by the Owner and a moderately developed design

by the architect. The design-builder is typically either the general contractor or design professional (architect or engineer). This system minimizes the project risk for an owner and reduces the delivery schedule by overlapping the design and construction phases of a project. Where the design-builder is the contractor, any required design professionals will typically be retained directly by the contractor.

As outlined in [Chapter 3](#), there are potential problems associated with the DB delivery system. As an example, cost estimating for a DB project can be difficult say when design documents are preliminary and liable to change over the course of the project. To address this situation, DB contracts are often written to allow for unexpected situations without penalizing either the design-builder or the owner. Organizations such as the Design/Build Institute of America can provide standardized form contracts for design-builders to use, although it is not unusual for the design-builder to provide its own contractual documents, particularly for well-established firms and firms that have previously constructed similar projects.

14.2.3 Construction Manager as Constructor

Using this delivery method, a CM is hired prior to completion of the design phase to act as a project coordinator and general contractor. As discussed in [Chapter 3](#), hiring a CM during the design phase, allows the CM to work directly with the architect or project team and circumvent any potential design issues prior to completion of the construction documents. Once the tender documents have been completed, the CM-adviser invites contractors or subcontractors to bid for the various divisions of work for the project.



14.3 BID SOLICITATION AND TYPES OF BUILDING CONTRACTS

Bid solicitation is the process of making published construction data (tender documents) readily available to interested parties, such as CMs, contractors, and the public.

Project owners release prepared project details including contract documents and specifications in the form of tender documents (normally for a fee) to interested general contractors, subcontractors, and other interested parties in an attempt to solicit bids. These services are usually subscription based, or a flat fee is charged for a copy of the tender documents. It is

difficult to structure a formula for quoting an exact fee largely because it is highly uncommon for two properties to be exactly alike in terms of all the variables that need to be considered. Moreover, it becomes a guessing game trying to quote a fee on a cost per square foot basis without having all the information up front.

The owner is the person responsible for determining the type of contract to be used on a particular project. This will be partly determined by several factors such as the type of project and the amount of risk the owner is willing to accept. There are several basic types of construction contracts currently in use. They are:

- Lump Sum
- Cost-Plus
- GMP
- Unit Price
- Project Management
- Labor
- Negotiated

14.3.1 Lump Sum (or Fixed Fee)

Typically used with DBB method of project procurement, and often in Building Contracts where the contractor agrees to supply all labor and materials for a fixed sum. This type of Contract (also sometimes called “Stipulated Sum” contract) is suitable if the scope and schedule of the project are sufficiently defined to allow the estimation of the project costs. Should the building contractor miscalculate, there is nowhere to go except to absorb the cost. It is the most widely used form of contract in building construction and is generally a more favorable type of building contract for the owner because cost of the project is known from the outset. The cost of management is placed squarely on the shoulders of the contractor. It also adds responsibility in the precontract assessment carried out by the contractor to ensure that all potential contingencies are covered off as agreed extras. This type of Contract provides a degree of certainty for both parties because the Contract clearly spells out what is involved. Once the contract is signed, both parties (the owner and contractor) must live up to the terms of the contract and any modifications that follow will be considered “change orders” which will add to the cost and possible delays. A lump sum agreement normally protects the project owner from unethical contractors hoping to take advantage of an owner.

According to Mark Cladny of *On Site Systems*, there are many factors which determine if the Lump Sum method is suited to a project. They include:

1. Is there a requirement to have lump sum competitive bidding due to public or internal policy concerns? Do these policies preclude other contracting methods?
2. Have plans and specifications been developed by an Architect and related consultants that exactly depict the project requirements? With the competitive nature of the architectural industry, many architects and designers have come to rely on previously generated details and “canned” specifications, without thoroughly modifying them to depict the current project.
3. Has sufficient time and resources been allocated to produce and final design prior to the start of construction?
4. Does the owner or architect possess the expertise to issue partial documents and coordinate the design and construction process to allow concurrency of design and construction activities by the issuance of bid packages?
5. Have the budgets and financing allowed consideration for the expected amount of scope and nonscope changes? Scope changes are ones regarded as different from the bidding documents due to any number of issues, including:
 - a. Unexpected or nondepicted site conditions.
 - i. Changes to the building’s characteristic due to program changes or user requirements.
 - ii. Changes in technology from the design phase to building turn over.
 - b. Nonscope changes could include:
 - i. Claims for delay due to lack of design coordination, inadequate, or nondescript documents.
 - ii. Ambiguity regarding subsystem design responsibility.
 - iii. Interference with other contractors or public agencies.
 - iv. Interference with existing tenants or occupants.

Advantages of Lump Sum Contract

- Low financial risk to Owner. The lump sum Contract price is not subject to any adjustment on the basis of the Contractor’s cost experience in performing the Contract (unless agreed by both parties). This Contract type places the maximum risk and full responsibility for all costs and resulting profit or loss upon the Contractor.

- As the price is fixed, unforeseen contingencies or variations in material or labor prices will not affect the Owner.
- Costs are known at the outset.
- Contractor selection is relatively easy.
- Provides a degree of certainty for both parties because the Contract clearly spells out the expectations and what is involved in the Contract.
- A maximum incentive is provided for the Contractor to control costs and perform effectively and impose a minimum administrative burden upon the Contracting parties.

Disadvantages of a Lump Sum Contract

- The Architect is not involved as this Contract is an agreement between the Owner and the Contractor for a final fixed price sum. As the Architect does exercise his/her traditional role, the quality of work cannot be checked and controlled by an expert.
- It is difficult and costly to make changes.
- Because the specifications may not be clear, the Contractor can use alternative/inferior brands of materials. Only minimum specifications are usually provided.
- Early project start not possible due to need to complete design prior to bidding process.
- Likewise there, one can expect considerable ambiguity in the specifications, measurements, mode of payment, etc.
- Even though the Contract is executed on a fixed price basis, the Contractor may nevertheless claim extras by giving different reasons, since the specifications, measurements, etc. are not precise.
- The Contractor requests money in advance from the Owner and then he proceeds with the work at his own pace. In some cases, the Contractors may deliberately hold up the work toward the end, so as to extract maximum money from the Owner, leaving the Owner feeling helpless as his money is tied up with the Contractor.

Building contractors normally add 10 to 15% to the expected cost of the project to account for unforeseen contingencies. This amount may be increased based on the builder's assessment of risk and partly depends on the type of project and special circumstances surrounding the project and can either be agreed to be included in the total cost of the contract or agreed as a maximum contingency fund. This means, that provided no surprises eventuate, the owner will not be liable to pay this sum. However, if there are cost overruns associated with the work but which are not due to errors

or omissions in the design, but instead are the result of the contractor's poor performance, or even the weather, then the contractor must absorb the loss with no additional requests for compensation from the owner. However, in practice, sometimes when costs exceed the estimates, disputes may arise over the scope of work or attempts to substitute less expensive materials for those specified. Also, if the contractor is able through superior performance achieve cost savings, these benefits will go solely to the builder. A lump sum contract can also be used in conjunction with an award-fee incentive and performance incentives, providing that the award fee or incentive is based solely on factors other than cost. As for the Stipulated Sum contract, this may contain a section that stipulates certain unit price items. Unit Price is often used for those items that have indefinite quantities, such as pier depth. A fixed price is established for each unit of work.

A Lump Sum Contract With Price Adjustment

This provides for an upward or downward revision of the stated Contract price upon the occurrence of specified contingencies. A lump sum Contract with economic price adjustment can be used when there is serious doubt regarding the market's stability or regarding labor conditions that may exist during an extended period of Contract performance, and contingency allowances that would otherwise be included in the Contract price can be identified and covered separately in the Contract. It is important here to ensure that contingency allowances are not duplicated by inclusion in both the base price and the adjustment requested by the Contractor under economic price adjustment clause.

14.3.2 Cost-Plus Contract

This is a Contract agreement wherein the Owner agrees to pay the cost of all labor and materials on a cost-plus basis, i.e., the owner reimburses the contractor for all costs associated with the contract in addition to a fee covering the contractor's profit and nonreimbursable overhead costs. It is therefore somewhat like a Labor Contract, except that here the Contractor buys the materials and provides the labor and is reimbursed accordingly. Cost-plus contracts can be either cost-plus a percentage of costs, under which the fee is an agreed-upon percentage of the "costs" or costs plus a fixed fee where the fee is independent of the contractor's "costs." With this type of contract, it is important to define exactly what is included in the "costs" (e.g., are soft costs such as supervision and overhead reimbursable?). Because of the discretionary and subjective nature of a cost-plus building

contract—it ends up being the best for the contractor and the riskiest type of contract for the investor or building owner. The owner may suddenly discover that the projects end up being twice what was initially agreed to. Care must therefore be applied when using this type of agreement as it is frequently open to abuse.

This is the most beneficial contract for the contractor, since any additional costs will be covered, thus guaranteeing them a profit regardless of project cost. However, this bid model must not be allowed to be used by building contractors as a haven for poor estimating. The various types of additional costs should be discussed with the contractor at the time the bid is being reviewed. Although surprises are not uncommon in construction, they can be kept to a minimum by a careful drafting of the contract. This type of contract is usually used for projects where the scope of the work is indeterminate or very uncertain and the kinds of labor, material, and equipment needed are also difficult to ascertain. It is also used for very specialized and where the scope is difficult to define or when time to execute the project is the most important factor and construction is required to start before the completion of the contract documents. Under this arrangement, complete records of all time and materials spent by the Contractor on the work must be accurately maintained.

Advantages of the Cost Plus Contract

- Because it provides the Contractor with an additional amount at the end of the project, it maximizes the incentive for the Contractor to control costs and perform effectively and on schedule.
- It has similar advantages to that of Labor Contracts.

Disadvantages of the Cost Plus Contract

- In this Contract the quality of work cannot be checked or controlled by an expert because the Architect no longer has a role to play.
- It is difficult to verify if the Contractor's records are accurate which is vital since the Contractor's reimbursement is based on the records of the workers he has employed and the materials purchased.

14.3.3 Guaranteed Maximum Price

GMP contracts are becoming more popular as a vehicle to minimize risk, avoid claims, and integrate the diverse interests of a complex project. The GMP contract is essentially the same as the cost-plus-fee, except there is a set price so the total cost and fee cannot exceed. This type of contract is

based on competitive bids for each trade subcontract, but the Contractor/Administrator charges an additional fee for taking on the risk of the guarantee. This type of contract is essentially a variation of the cost-plus contract but should not be confused with it. It is more suited for projects where the scope is well defined and that is especially suited for turn-key projects. With this type of contract, the contractor is reimbursed for actual costs incurred for labor, materials, equipment, subcontractors, overhead, and profit up to an agreed maximum fixed price amount. The contractor also warrants that the project will be constructed in accordance with the contract documents and that the cost of the project to the owner will not exceed the agreed total maximum price. Costs over the maximum price shall be borne by the contractor and any savings below the maximum price will revert to the owner.

It is important that the owner from the outset clearly states whether this maximum price reflects the total costs (fee excluded) or the total costs the owner pays including the fee. Normally the owner pays the fee, and the contractor pays for costs in excess of the maximum. The Contractor is typically allocated contingency amount to pay for construction changes that are within the design intent of the project. However, changes that exceed the design intent require approval by all stakeholders. Here the owner tends to play an active role throughout the entire process. The whole issue of cost is manageable when the savings are shared rather than negotiated from an adversarial position. Another advantage of GMP occurs when work must start ahead of final drawings. There are often issues that delay completion of the drawings and therefore start of construction. The GMP format allows owners to minimize risk when proceeding with work ahead of final drawings. Penalty and incentive clauses are often included in the agreement relating to costs, schedule, and quality performance. This type of contract is sometimes preferred when a design is less than 100% complete.

14.3.4 Unit Price Contract

This type of contract is typically chosen when both parties are unable to determine the cost ahead of time. Here, the owner provides specific unit price to limit spending. In this type of contract, the work to be performed is broken into various segments, usually by construction trade, and a fixed price is established for each unit of work. The contractor is paid as the contract proceeds by requiring that the actual quantities of work completed is measured, and these quantities multiplied by the preagreed per-unit price. The final price of the project depends on the final quantities of the items used to carry out the work, which may eventually vary from what was

initially estimated. This allows the terms of this type of Contract to accommodate some flexibility for price adjustment. This means that the agreed to value may be subject to amendment if the actual volume is reduced or exceeds the original negotiated terms and price. Tender estimates provided by contractors are based on specifications and estimated quantities supplied by the owner. However, during and after the work, the price is now based on actual quantities completed and not estimated quantities. For the contractor, this removes some of the risk in the bidding process because payment is based on actual quantities and not lump sum. The contractor's unit price must cover both direct and indirect costs, overheads, contingencies, and profit. For this reason, the owner usually provides fixed quantities for contractors to use as the basis of their unit price costing. For example, painting is typically done on a square foot basis. However, when additional work is required, a separate invoice should be presented (Fig. 14.4).

Unit price contracts are seldom used for an entire major construction project, but they are frequently used for agreements with subcontractors and for maintenance and repair work. This type of contract is also typically suitable for projects where the quantities are ill defined and therefore cannot be accurately measured before the project starts such as highway type projects. Thus, the owner could provide quantities for excavation, pipe laying, and backfill. The contractor would quote a dollar amount per cubic yard for soil excavation, a dollar amount per linear foot of piping laid, and a dollar amount per cubic yard of backfill installed and come up with a total bid based upon the quantities that the owner provided. The project's final price will not be known with certainty until the project is completed. Additionally, it is prudent for the owner or the owner's representative to "track" actual quantities by some method of measuring—counting truckloads of materials, weighing steel, etc.

Advantages of a Unit Price Contract

- The Architect is involved because it is he/she who provides the quantities of each item (in the Bill of quantities) and negotiates the unit prices with the Contractor. Moreover, with the Unit Price Contract, the Owner makes payments to the Contractor only after the Architect has verified the measurements at Site and certified the Contractor's bills for payment. This provides additional safety to the Owner who pays only for the volume of work done at site and not for anything extra. Additionally, there is the assurance (because the Architect is involved), that the quality of the work will be according to the specifications and contract documents.

**BILLING FORM
ADDITIONAL WORK PERFORMED**

EMPLOYEE NAME:

DATE:

PROJECT NO.

JOB NAME:

FOR PERIOD UP TO AND INCLUDING: _____

**DESCRIPTION OF WORK PERFORMED, INCLUDING WHO WAS INVOLVED,
DATES, ETC.**

HOURS: _____

EXPENSES: _____

APPROVED:

SIGNATURE:

Figure 14.4 Example of type of billing form used for additional work completed.

- “Typical” drawings can be used for competitive bidding.
- The Contractor has to initially invest his own money for starting the work, and so the Owner does not have to give the Contractor a large advance.
- With the Unit Price type of Contract, selection of a contractor is generally easier because it is generally considered to be the most scientific and most suitable for construction projects where the different types of items, but not their numbers, can be accurately identified in the Contract documents.

- The Contractor is also safeguarded against any potential contingencies or variations in labor or material rates.
- There is a degree of built-in flexibility in that the scope and quantities are easily adjustable.

Disadvantages of a Unit Price Contract

The main disadvantage for the Contractor is that initially he has to invest his own money. And while this is one of the most preferred Contracts in building construction, it is not unusual to combine a Unit Price Contract for parts of the project with other types of Contracts such as a Lump Sum Contract. Other disadvantages are not knowing the final cost at the outset (because bills of quantities at bid time are only estimates), and additional site staff is needed to measure, control, and report on completed units.

14.3.5 Project Management Contract

Most construction projects have one individual in charge coordinating the various trades to make sure no step is missed and to make sure the work is properly executed. This requires a considerable amount of expertise. In this type of Contract the Architect agrees to manage the Contract, as defined by the scope of the agreement, for a specified duration of time for monetary consideration. To complete a project successfully requires good communication between client and project manager. The Project Management Contract addresses many of the most common causes of conflict in this type of agreement. This type of Contract can be short term or long term.

Advantages of Project Management

- Clients can focus on their core objectives while the Architect (Project Manager) looks after the management of the Project and related issues, ensuring that deadlines are met, quality is maintained, and costs are controlled and within the budget.
- The Project Manager's duties include coordination with all the agencies, including the Consultants, the Contractor, and the Suppliers to ensure that the construction of the project proceeds as planned.

Disadvantages of Project Management

Many Clients hesitate to go in for Project Management Contract partly because they have to pay extra for project management, in addition to the fees paid to the Architect. On the other hand, there are also many of Clients who will opt for Project management because it saves them from a lot of headache and because it allows them to concentrate on their work

as the project proceeds forward. In the long run, the Client actually saves since the project is completed on time, and costs are controlled within the budget.

14.3.6 Labor

In this type of Contract, the Contractor only supplies the labor while the Owner buys and supplies all the material required for the execution of the project. The system of employing Contract labor is prevalent in many industries including Construction, involving skilled and semiskilled jobs. The workman is considered to be employed as Contract Labor when he is hired in connection with the work by or through a Contractor. Contract workmen are classified as indirect employees; persons who are hired, supervised, and remunerated by a Contractor who, in turn, is compensated by the Owner of the project. Contract labor has to be employed for work which is specific and for definite duration.

Advantages of a Labor Contract

- Some Owners prefer this kind of Contract because by buying all the material himself, he is able to pocket much of the Contractor's profit.
- This type of Contract ensures that the Owner can buy the materials of his choice and can be sure of the brand and quality that will be used in the construction.

Disadvantages of a Labor Contract

- Labor Contracts dismisses the role of the Architect who no longer has a role to play, and so quality of work cannot be checked or controlled by an expert.
- Not being schooled in material quality, it is easy for the Owner to be misled on the quality of sand, bricks etc.
- There is a lot of stress and tension involved in running around and organizing for the supply of materials, etc. on time as the work progresses.
- Often, casual nature of employment, inferior labor status, lack of job security, and poor economic conditions are some of the major attributes of Contract labor.
- The Contractor can often strike a better bargain when negotiating with suppliers and vendors because the Owner is a onetime Client, whereas the Contractor normally has the advantage of being a regular.
- There is a strong possibility of pilferage of material stored at site.

- Often some laborers, masons etc. fail to turn up to site as they may be lured for a day to some other site and hence the work gets delayed.
- As workers are generally paid on a daily basis, an unscrupulous labor Contractor may purposely go slow to take longer to complete the job with the hope of getting paid more.

14.3.7 Negotiated Contract

This type of contract is not dissimilar to the DBB method in that the project's design and construction are performed by different firms. Sometimes a negotiated contract is used in lieu of the tendering process, especially when an owner has had previous experience with a particular contractor. That contractor may be invited to submit a proposal or offer to the owner or the owner's representative based on the contract documents. This is then followed by negotiations regarding price, scope of work, time to execute the project, and other contractual issues. Once an agreement is reached, a contract is signed for constructing the project. Negotiations may also form part of a tendering process. Upon evaluating the submitted tenders, a short list of top ranking firms is created, which is then followed by negotiations regarding work content, risk, liability issues, and contract-related issues. If the owner decides on negotiating with the top ranking firms after the tenders are opened and analyzed, this must be made clear to all via the invitation to tender to ensure impartiality.

The latest DB documents use one agreement for both design and construction, with three possible methods of payment available to the parties. These are:

- Stipulated Sum Cost Plus a Fee with a GMP
- Cost Plus a Fee Without a GMP



14.4 AMERICAN INSTITUTE OF ARCHITECTS CONTRACT DOCUMENTS

The AIA website states that there are more than 100 forms and contracts that comprise AIA Contract Documents. According to the AIA, "These forms and contracts define the relationships and terms involved in design and construction projects." The AIA prepared and developed these contracts with the consensus of owners, contractors, attorneys, architects, engineers, design professionals, and others. The result is a comprehensive collection of contracts and forms that are widely recognized as the

industry standard. The AIA organizes contract documents using two basic methods, these are by: (1) Families which are based on types of projects or particular project delivery methods or (2) by Series which is based on the use of the document. For the series method, the AIA Contract Documents are divided into six alphanumeric series according to document use or purpose. The AIA advises users to exercise independent judgment and may require the advice of legal counsel on deciding which documents are appropriate for a particular project. Current AIA Documents by Series are shown below:

Series	Document type	Document numbers
A	Owner/Contractor Agreements	A101, A102, A103, A105, A107, A132, A133, A134, A141, A142, A151, A195, A201, A232, A251, A295, A305, A310, A312, A401, A441, A503, A533, A701, A751
B	Owner/Architect Agreements	B101, B102, B103, B104, B105, B106, B107, B108, B109, B132, B142, B143, B144ARCH-CM, B152, B153, B161, B162, B188, B195, B201, B202, B203, B204, B205, B206, B207, B209, B210, B211, B212, B214, B252, B253, B305, B503, B509, B727, B727,
C	Other Agreements	C101, C106, C132, C191, C195, C196, C197, C198, C199, C401, C441, C727
D	Miscellaneous Documents	D101, D200, D503
E	Exhibits	E201, E202
F	[Reserved]	[Reserved]
G	Contract Administration and Project Management Forms	G601, G602, G612, G701, G701S, G701CMa, G702, G702S, G703, G703S, G704, G704CMa, G704DB, G705, G706, G706A, G707, G707A, G709, G710, G711, G712, G714, G714CMa, G715, G716, G732, G736, G737, G801, G802, G803, G804, G806, G807, G808, G808A, G809, G810

14.4.1 A-Series: Owner/Contractor Agreements

A101–2007, Standard Form of Agreement Between Owner and Contractor Where the Basis of Payment is a Stipulated Sum

AIA Document A101–2007 is a standard form of agreement between owner and contractor for use where the basis of payment is a stipulated sum (fixed price). A101 adopts by reference, and is designed for use

with, AIA Document A201–2007, General Conditions of the Contract for Construction. A101 is suitable for large or complex projects. For projects of a more limited scope, use of AIA Document A107–2007, Agreement Between Owner and Contractor for a Project of Limited Scope, should be considered. For even smaller projects, consider AIA Document A105–2007, Agreement Between Owner and Contractor for a Residential or Small Commercial Project. NOTE: A101–2007 replaces A101–1997 (expired 2009).

A102–2007 (formerly A111–1997), Standard Form of Agreement Between Owner and Contractor Where the Basis of Payment is the Cost of the Work Plus a Fee with a Guaranteed Maximum Price

This standard form of agreement between owner and contractor is appropriate for use on large projects requiring a GMP, when the basis of payment to the contractor is the cost of the work plus a fee. AIA Document A102–2007 is not intended for use in competitive bidding. AIA Document A102–2007 adopts by reference and is intended for use with AIA Document A201–2007, General Conditions of the Contract for Construction. NOTE: A102–2007 replaces A111–1997 (expired 2009).

A103–2007 (formerly A114–2001), Standard Form of Agreement Between Owner and Contractor Where the Basis of Payment is the Cost of the Work Plus a Fee without a Guaranteed Maximum Price

AIA Document A103–2007 is appropriate for use on large projects when the basis of payment to the contractor is the cost of the work plus a fee, and the cost is not fully known at the commencement of construction. AIA Document A103–2007 is not intended for use in competitive bidding. A103–2007 adopts by reference, and is intended for use with, AIA Document A201–2007, General Conditions of the Contract for Construction. NOTE: A103–2007 replaces A114–2001 (expired 2009).

A105–2007 (formerly A105–1993 and A205–1993), Standard Form of Agreement Between Owner and Contractor for a Residential or Small Commercial Project

AIA Document A105–2007 is a stand-alone agreement with its own general conditions; it replaces A105–1993 and A205–1993 (expired 2009). AIA Document A105–2007 is for use on a project that is modest in size and brief in duration and where payment to the contractor is based on a stipulated sum (fixed price). For larger and more complex projects, other AIA agreements are more suitable, such as AIA Document A107–2007,

Standard Form of Agreement Between Owner and Contractor for a Project of Limited Scope. AIA Documents A105–2007 and B105–2007, Standard Form of Agreement Between Owner and Architect for a Residential or Small Commercial Project, comprise the Small Projects family of documents. Although A105 and B105 share some similarities with other agreements, the Small Projects family should NOT be used in tandem with agreements in other document families without careful side-by-side comparison of contents.

A107–2007, Standard Form of Agreement Between Owner and Contractor for a Project of Limited Scope

AIA Document A107–2007 is a stand-alone agreement with its own internal general conditions and is intended for use on construction projects of limited scope. It is intended for use on medium-to-large sized projects where payment is based on either a stipulated sum or the cost of the work plus a fee, with or without a GMP. Parties using AIA Document A107–2007 will also use A107 Exhibit A, if using a cost-plus payment method. AIA Document B104–2007, Standard Form of Agreement Between Owner and Architect for a Project of Limited Scope, coordinates with A107–2007 and incorporates it by reference.

For more complex projects, parties should consider using one of the following other owner/contractor agreements: AIA Document A101–2007, A102–2007, or A103–2007. These agreements are written for a stipulated sum, cost of the work with a GMP, and cost of the work without a GMP, respectively. Each of them incorporates by reference AIA Document A201–2007, General Conditions of the Contract for Construction. For single family residential projects, or smaller and less complex commercial projects, parties may wish to consider AIA Document A105–2007, Agreement Between Owner and Contractor for a Residential or Small Commercial Project. NOTE: A107–2007 replaces A107–1997 (expired 2009).

A132–2009 (formerly A101CMa–1992), Standard Form of Agreement Between Owner and Contractor, Construction Manager as Adviser Edition

AIA Document A132–2009 is a standard form of agreement between owner and contractor for use on projects where the basis of payment is either a stipulated sum (fixed price) or cost of the work plus a fee, with or without a GMP. In addition to the contractor and the architect, a CM assists the owner in an advisory capacity during design and construction.

The document has been prepared for use with AIA Documents A232–2009, General Conditions of the Contract for Construction, CM as Adviser Edition; B132–2009, Standard Form of Agreement Between Owner and Architect, CM as Adviser Edition; and C132–2009, Standard Form of Agreement Between Owner and CM as Adviser. This integrated set of documents is appropriate for use on projects where the CM only serves in the capacity of an adviser to the owner, rather than as constructor (the latter relationship being represented in AIA Documents A133–2009 and A134–2009). NOTE: A132–2009 replaces A101CMa–1992 (expired 2010).

A133–2009 (formerly A121CMc–2003), Standard Form of Agreement Between Owner and Construction Manager as Constructor where the basis of payment is the Cost of the Work Plus a Fee with a Guaranteed Maximum Price

AIA Document A133–2009 is intended for use on projects where a CM, in addition to serving as adviser to the owner, assumes financial responsibility for construction of the project. The CM provides the owner with a GMP proposal, which the owner may accept, reject, or negotiate. Upon the owner's acceptance of the proposal by execution of an amendment, the CM becomes contractually bound to provide labor and materials for the project and to complete construction at or below the GMP. The document divides the CM's services into two phases: the preconstruction phase and the construction phase, portions of which may proceed concurrently to fast track the process. AIA Document A133–2009 is coordinated for use with AIA Documents A201–2007, General Conditions of the Contract for Construction, and B103–2007, Standard Form of Agreement Between Owner and Architect for a Large or Complex Project. A133–2009 replaces A121CMc–2003 (expired 2010).

CAUTION: To avoid confusion and ambiguity, do not use this construction management document with any other AIA construction management document.

A134–2009 (formerly A131CMc–2003), Standard Form of Agreement Between Owner and Construction Manager as Constructor where the basis of payment is the Cost of the Work Plus a Fee without a Guarantee Maximum Price

Similar to AIA Document A133–2009, AIA Document A134–2009 is intended for use when the owner seeks a CM who will take on responsibility for providing the means and methods of construction. However, in AIA Document A134–2009 the CM does not provide a GMP. A134–2009

employs the cost-plus-a-fee method, wherein the owner can monitor cost through periodic review of a control estimate that is revised as the project proceeds.

The agreement divides the CM's services into two phases: the preconstruction phase and the construction phase, portions of which may proceed concurrently to fast track the process. A134–2009 is coordinated for use with AIA Documents A201–2007, General Conditions of the Contract for Construction, and B103–2007, Standard Form of Agreement Between Owner and Architect for a Large or Complex Project. A134–2009 replaces A131CMc–2003 (expired 2010).

CAUTION: To avoid confusion and ambiguity, do not use this construction management document with any other AIA construction management document.

A141–2004, Agreement Between Owner and Design-Builder

AIA Document A141–2004 replaces A191–1996 (expired) and consists of the agreement and three exhibits: Exhibit A, Terms and Conditions; Exhibit B, Determination of the Cost of the Work; and Exhibit C, Insurance and Bonds. Exhibit B is not applicable if the parties select to use a stipulated sum. AIA Document A141–2004 obligates the design-builder to execute fully the work required by the DB documents, which include A141 with its attached exhibits, the project criteria and the design-builder's proposal, including any revisions to those documents accepted by the owner, supplementary, and other conditions, addenda and modifications. The Agreement requires the parties to select the payment type from three choices: (1) Stipulated Sum, (2) cost of the work plus design-builder's fee, and (3) cost of the work plus design-builder's fee with a GMP. A141–2004 with its attached exhibits forms the nucleus of the DB contract. Because A141 includes its own terms and conditions, it does not use AIA Document A201.

A142–2004, Agreement Between Design-Builder and Contractor

AIA Document A142–2004 replaces AIA Document A491–1996 (expired) and consists of the agreement and five exhibits: Exhibit A, Terms and Conditions; Exhibit B, Preconstruction Services; Exhibit C, Contractor's Scope of Work; Exhibit D, Determination of the Cost of the Work; and Exhibit E, Insurance and Bonds. Unlike AIA Document B491–1996, AIA Document A142–2004 does not rely on AIA Document A201 for its general conditions of the contract. A142–2004 contains its own terms and conditions.

A142–2004 obligates the contractor to perform the work in accordance with the contract documents, which include A142 with its attached exhibits, supplementary and other conditions, drawings, specifications, addenda, and modifications. Like AIA Document A141–2004, AIA Document A142–2004 requires the parties to select the payment type from three choices: (1) Stipulated Sum, (2) Cost of the Work Plus Design-Builder's Fee, and (3) Cost of the Work Plus Design-Builder's Fee with a GMP.

A151–2007 (formerly A175ID–2003), Standard Form of Agreement Between Owner and Vendor for Furniture, Furnishings and Equipment where the basis of payment is a Stipulated Sum

AIA Document A151–2007 is intended for use as the contract between owner and vendor for furniture, furnishings, and equipment (FF&E) where the basis of payment is a stipulated sum (fixed price) agreed to at the time of contracting. AIA Document A151–2007 adopts by reference and is intended for use with AIA Document A251–2007, General Conditions of the Contract for Furniture, Furnishings, and Equipment. It may be used in any arrangement between the owner and the contractor where the cost of FF&E has been determined in advance, either through bidding or negotiation. NOTE: A151–2007 replaces A175ID–2003 (expired 2009).

A195–2008, Standard Form of Agreement Between Owner and Contractor for Integrated Project Delivery

AIA Document A195–2008 is a standard form of agreement between owner and contractor for a project that utilizes integrated project delivery (IPD). AIA Document A195–2008 primarily provides only the business terms and conditions unique to the agreement between the owner and contractor, such as compensation details and licensing of instruments of service. A195 does not include the specific scope of the contractor's work; rather, it incorporates by reference AIA Document A295–2008, General Conditions of the Contract for IPD, which sets forth the contractor's duties and obligations for each of the six phases of the project, along with the duties and obligations of the owner and architect. Under A195–2008, the contractor provides a GMP. For that purpose, the agreement includes a GMP amendment at Exhibit A.

A201–2007, General Conditions of the Contract for Construction

The general conditions are an integral part of the contract for construction for a large project, and they are incorporated by reference into

the owner/contractor agreement. They set forth the rights, responsibilities, and relationships of the owner, contractor, and architect. Though not a party to the contract for construction between owner and contractor, the architect participates in the preparation of the contract documents and performs construction phase duties and responsibilities described in detail in the general conditions. AIA Document A201–2007 is adopted by reference in owner/architect, owner/contractor, and contractor/subcontractor agreements in the Conventional (A201) family of documents; thus, it is often called the “keystone” document. NOTE: A201–2007 replaces A201–1997 (expired 2009).

A232–2009 (formerly A201CMA–1992), General Conditions of the Contract for Construction, Construction Manager as Adviser Edition

AIA Document A232–2009 sets forth the rights, responsibilities, and relationships of the owner, contractor, CM, and architect. A232–2009 is adopted by reference in owner/architect, owner/contractor, and owner/CM agreements in the CMA family of documents. Under A232–2009, the CM serves as an independent adviser to the owner, who enters into a contract with a general contractor or multiple contracts with prime trade contractors. NOTE: A232–2009 replaces A201CMA–1992 (expired 2010).

CAUTION: Do not use A232–2009 in combination with agreements where the CM takes on the role of constructor, such as in AIA Document A133–2009 or A134–2009.

A251–2007 (formerly A275ID–2003), General Conditions of the Contract for Furniture, Furnishings and Equipment

AIA Document A251–2007 provides general conditions for the AIA Document A151–2007, Standard Form Agreement between Owner and Vendor for Furniture, Furnishings, and Equipment where the basis of payment is a Stipulated Sum. AIA Document A251–2007 sets forth the duties of the owner, architect, and vendor, just as AIA Document A201–2007, General Conditions of the Contract for Construction, does for building construction projects. Because the Uniform Commercial Code (UCC) governs the sale of goods and has been adopted in nearly every jurisdiction, A251–2007 recognizes the commercial standards set forth in Article 2 of the UCC and uses certain standard UCC terms and definitions. A251 was renumbered in 2007 and was modified, as applicable, to coordinate with AIA Document A201–2007. NOTE: A251–2007 replaces A275ID–2003 (expired 2009).

A295–2008, General Conditions of the Contract for Integrated Project Delivery

AIA Document A295–2008, provides the terms and conditions for AIA Documents A195–2008 Standard Form of Agreement Between Owner and Contractor for IPD, and B195–2008, Standard Form of Agreement Between Owner and Architect for IPD, both of which incorporate AIA Document A295–2008 by reference. Those agreements provide primarily only business terms and rely upon A295–2008 for the architect's services, the contractor's preconstruction services, and the conditions of construction. A295 not only establishes the duties of the owner, architect, and contractor, but also sets forth in detail how they will work together through each phase of the project: conceptualization, criteria design, detailed design, implementation documents, construction, and closeout. A295 requires that the parties utilize building information modeling (BIM).

A305–1986, Contractor's Qualification Statement

An owner preparing to request bids or to award a contract for a construction project often requires a means of verifying the background, references, and financial stability of any contractor being considered. These factors, along with the time frame for construction, are important for an owner to investigate. Using AIA Document A305–1986, the contractor may provide a sworn, notarized statement and appropriate attachments to elaborate on important aspects of the contractor's qualifications.

A310–2010, Bid Bond

AIA Document A310–2010, a simple, one-page form, establishes the maximum penal amount that may be due to the owner if the selected bidder fails to execute the contract or fails to provide any required performance and payment bonds. NOTE: A310–2010 replaces AIA Document A310–1970, which expires on December 31, 2011.

A312–2010, Performance Bond and Payment Bond

AIA Document A312–2010 incorporates two bonds—one covering the contractor's performance and the other covering the contractor's obligations to pay subcontractors and others for material and labor. In addition, AIA Document A312–2010 obligates the surety to act responsively to the owner's requests for discussions aimed at anticipating or preventing a contractor's default. NOTE: A312–2010 replaces AIA Document A312–1984, which expires on December 31, 2011.

A401–2007, Standard Form of Agreement Between Contractor and Subcontractor

AIA Document A401–2007 establishes the contractual relationship between the contractor and subcontractor. It sets forth the responsibilities of both parties and lists their respective obligations, which are written to parallel AIA Document A201–2007, General Conditions of the Contract for Construction, which A401–2007 incorporates by reference. AIA Document A401 may be modified for use as an agreement between the subcontractor and a subsubcontractor and must be modified if used where AIA Document A107–2007 or A105–2007 serves as the owner/contractor agreement. NOTE: A401–1997 replaces A401–1997 (expires 2009).

A441–2008, Standard Form of Agreement Between Contractor and Subcontractor for a Design-Build Project

AIA Document A441–2008 is a fixed price agreement that establishes the contractual relationship between the contractor and subcontractor in a DB project. AIA Document A441–2008 incorporates by reference the terms and conditions of AIA Document A142–2004, Standard Form of Agreement Between Design-Builder and Contractor and was written to ensure consistency with the AIA 2004 DB family of documents. Because subcontractors are often required to provide professional services on a DB project, A441 provides for that possibility.

A503–2007 (formerly A511–1999), Guide for Supplementary Conditions

AIA Document A503–2007 is not an agreement but is a guide containing model provisions for modifying and supplementing AIA Document A201–2007, General Conditions of the Contract for Construction. It provides model language with explanatory notes to assist users in adapting AIA Document A201–2007 to specific circumstances. A201–2007, as a standard form document, cannot cover all the particulars of a project. Thus, AIA Document A503–2007 is provided to assist A201–2007 users either in modifying it or developing a separate supplementary conditions document to attach to it. NOTE: A503–2007 replaces A511–1999 (expired 2009).

A533–2009 (formerly A511CMa–1993), Guide for Supplementary Conditions, Construction Manager as Adviser Edition

Similar to AIA Document A503–2007, AIA Document A533–2009 is a guide for amending or supplementing the general conditions document, AIA Document A232–2009. AIA Documents A533–2009 and A232–2009 should only be employed on projects where the CM is serving in the capacity of

adviser to the owner and not in situations where the CM is also the constructor (CMc document-based relationships). Like A503–2007, this document contains suggested language for supplementary conditions, along with notes on appropriate usage. NOTE: A533–2009 replaces A511CMA–1993 (expired 2010).

A701–1997, Instructions to Bidders

AIA Document A701–1997 is used when competitive bids are to be solicited for construction of the project. Coordinated with AIA Document A201, General Conditions of the Contract for Construction, and its related documents, AIA Document A701–1997 provides instructions on procedures, including bonding requirements, for bidders to follow in preparing and submitting their bids. Specific instructions or special requirements, such as the amount and type of bonding, are to be attached to, or inserted into, A701.

A751–2007 (formerly A775ID–2003), Invitation and Instructions for Quotation for Furniture, Furnishings and Equipment

AIA Document A751–2007 provides (1) the Invitation for Quotation for Furniture, Furnishings, and Equipment (FF&E) and (2) Instructions for Quotation for Furniture, Furnishings, and Equipment. These two documents define the owner's requirements for a vendor to provide a complete quotation for the work. The purchase of FF&E is governed by the UCC, and AIA Document A751–2007 was developed to coordinate with the provisions of the UCC. NOTE: A751–2007 replaces A775ID–2003 (expired 2009).

14.4.2 B-Series: Owner/Architect Agreements

B101–2007 Standard Form of Agreement Between Owner and Architect

B102–2007 Standard Form of Agreement Between Owner and Architect without a Predefined Scope of Architect's Services

B103–2007 Standard Form of Agreement Between Owner and Architect for a Large or Complex Project

B104–2007 Standard Form of Agreement Between Owner and Architect for a Project of Limited Scope

B105–2007 Standard Form of Agreement Between Owner and Architect for a Residential or Small Commercial Project

B106–2010 Standard Form of Agreement Between Owner and Architect for Pro Bono Services

B107–2010 Standard Form of Agreement Between Developer-Builder and Architect for Prototype(s) for Single Family Residential Project

B108–2009 Standard Form of Agreement Between Owner and Architect for a Federally Funded or Federally Insured Project

B109–2010 Standard Form of Agreement Between Owner and Architect for a Multi-Family Residential or Mixed Use Residential Project

B132–2009 Standard Form of Agreement Between Owner and Architect, Construction Manager as Adviser Edition

B142–2004 Standard Form of Agreement Between Owner and Consultant

where the Owner contemplates using the DB method of project delivery

B143–2004 Standard Form of Agreement Between Design-Builder and Architect

B144ARCH-CM–1993 Standard Form of Amendment for the Agreement Between Owner and Architect where the Architect Provides CONSTRUCTION MANAGEMENT Services as an Adviser to the Owner

B152–2007 Standard Form of Agreement Between Owner and Architect for Architectural Interior Design Services

B153–2007 Standard Form of Agreement Between Owner and Architect for Furniture, Furnishings and Equipment Design Services

B161–2002 Standard Form of Agreement Between Client and Consultant for use where the Project is located outside the United States

B162–2002 Abbreviated Form of Agreement Between Client and Consultant for use where the Project is located outside the United States

B188–1996 * Standard Form of Agreement Between Owner and Architect for Limited Architectural Services for Housing Projects

B195–2008 Standard Form of Agreement Between Owner and Architect for Integrated Project Delivery

B201–2007 Standard Form of Architect's Services: Design and Construction Contract Administration

B202–2009 Standard Form of Architect's Services: Programming

B203–2007 Standard Form of Architect's Services: Site Evaluation and Planning

B204–2007 Standard Form of Architect's Services: Value Analysis, for use where the Owner employs a Value Analysis Consultant

B205–2007 Standard Form of Architect's Services: Historic Preservation

B206–2007 Standard Form of Architect's Services: Security Evaluation and Planning

B207–2008 Standard Form of Architect's Services: On-Site Project Representation

B209–2007 Standard Form of Architect’s Services: Construction Contract Administration, for use where the Owner has retained another Architect for Design Services

* *AIA Documents B188–1986 and B727–1988 expire on April 30, 2012.*

B210–2007 Standard Form of Architect’s Services: Facility Support

B211–2007 Standard Form of Architect’s Services: Commissioning

B212–2010 Standard Form of Architect’s Services: Regional or Urban Planning

B214–2007 Standard Form of Architect’s Services: LEED Certification

B252–2007 Standard Form of Architect’s Services: Architectural Interior Design

B253–2007 Standard Form of Architect’s Services: Furniture, Furnishings and Equipment Design

B305–1993 Architect’s Qualification Statement

B503–2007 Guide for Amendments to AIA Owner-Architect Agreements

B509–2010 Guide for Supplementary Conditions to AIA Document B109–2010 for use on Condominium Projects

B727–1988 * Standard Form of Agreement Between Owner and Architect for Special Services

14.4.3 C-Series: Other Agreements

C101–1993 (formerly C801–1993), Joint Venture Agreement for Professional Services

AIA Document C101–1993 is intended for use by two or more parties to provide for their mutual rights and obligations in forming a joint venture. It is intended that the joint venture, once established, will enter into an agreement with the owner to provide professional services. The parties may be all architects, all engineers, a combination of architects and engineers, or another combination of professionals. The document provides a choice between two methods of joint venture operation. The “division of compensation” method assumes that services provided and the compensation received will be divided among the parties in the proportions agreed to at the outset of the project. Each party’s profitability is then dependent on individual performance of preassigned tasks and is not directly tied to that of the other parties. The “division of profit and loss” method is based on each party performing work and billing the joint venture at cost plus a nominal amount for overhead. The ultimate profit or loss of the joint

venture is divided between or among the parties at completion of the project, based on their respective interests. NOTE: AIA Document C101–1993 was renumbered in 2007, but its content remains the same as C801–1993 (expired May 2009).

C106–2007, Digital Data Licensing Agreement

AIA Document C106–2007 serves as a licensing agreement between two parties who otherwise have no existing licensing agreement for the use and transmission of digital data, including instruments of service. AIA Document C106–2007 defines digital data as information, communications, drawings, or designs created or stored for a specific project in digital form. AIA C106 allows one party to: (1) grant another party a limited nonexclusive license to use digital data on a specific project, (2) set forth procedures for transmitting the digital data, and (3) place restrictions on the license granted. In addition, C106 allows the party transmitting digital data to collect a licensing fee for the recipient's use of the digital data.

C132–2009 (formerly B801CMA–1992), Standard Form of Agreement Between Owner and Construction Manager as Adviser

AIA Document C132–2009 provides the agreement between the owner and the CM, a single entity who is separate and independent from the architect and the contractor and who acts solely as an adviser (CMA) to the owner throughout the course of the project. AIA Document C132–2009 is coordinated for use with AIA Document B132–2009, Standard Form of Agreement Between Owner and Architect, CM as Adviser Edition.

Both C132–2009 and B132–2009 are based on the premise that there will be a separate construction contractor or multiple prime contractors whose contract(s) with the owner will be jointly administered by the architect and the CM under AIA Document A232–2009. AIA Document C132–2009 is not coordinated with, and should not be used with, documents where the CM acts as the constructor for the project, such as in AIA Document A133–2009 or A134–2009. NOTE: C132–2009 replaces B801CMA–1992 (expired December 2010).

C191–2009, Standard Form Multi-Party Agreement for Integrated Project Delivery

AIA Document C191–2009 is a standard form multiparty agreement through which the owner, architect, contractor, and perhaps other key project participants execute a single agreement for the design, construction, and commissioning of a Project. AIA Document C191–2009 provides the framework for a collaborative environment in which the parties operate in furtherance

of cost and performance goals that the parties jointly establish. The nonowner parties are compensated on a cost-of-the-work basis. The compensation model is also goal oriented and provides incentives for collaboration in design and construction of the project. Primary management of the project is the responsibility of the Project Management Team, comprised of one representative from each of the parties. The Project Executive Team, also comprised of one representative from each of the parties, provides a second level of project oversight and issue resolution. The conflict resolution process is intended to foster quick and effective resolution of problems as they arise. This collaborative process has the potential to result in a high-quality project for the owner, and substantial monetary and intangible rewards for the other parties.

C195–2008, Standard Form Single Purpose Entity Agreement for Integrated Project Delivery

AIA Document C195–2008 is a standard form single purpose entity (SPE) agreement through which the owner, architect, CM, and perhaps other key project participants, each become members of a limited liability company. The sole purpose of the company is to design and construct a project utilizing the principles of IPD established in IPD: A Guide. AIA Document C195–2008 provides the framework for a collaborative environment in which the company operates in furtherance of cost and performance goals that the members jointly establish. To obtain project funding, the company enters into a separate agreement with the owner. To design and construct the project, the company enters into separate agreements with the architect, CM, other non-owner members, and with non-member consultants and contractors. The compensation model in the non-owner member agreements is goal-oriented and provides incentives for collaboration in design and construction of the project, and for the quick and effective resolution of problems as they arise. This highly collaborative process has the potential to result in a high quality project for the owner, and substantial monetary and intangible rewards for the other members.

C196–2008, Standard Form of Agreement Between Single Purpose Entity and Owner for Integrated Project Delivery

AIA Document C196–2008 is a standard form of agreement between a single purpose entity (“the SPE”) and a project owner, called the owner member. AIA Document C196–2008 is intended for use on a project where the project participants have formed the SPE utilizing AIA Document C195–2008, Standard Form SPE Agreement for IPD. AIA Document is coordinated with AIA Document C195–2008 to implement the principles of IPD, including the accomplishment of mutually agreed goals. C196 provides the terms under

which the owner member will fund the SPE in exchange for the design and construction of the project. The SPE provides for the design and construction of the project through separate agreements with other members, including an architect and CM, utilizing AIA Document C197–2008, Standard Form of Agreement Between SPE and Non-Owner Member for IPD. The SPE may also enter into agreements with non-member design consultants, specialty trade contractors, vendors and suppliers.

C197–2008, Standard Form of Agreement Between Single Purpose Entity and Non-Owner Member for Integrated Project Delivery

AIA Document C197–2008 is a standard form of agreement between a single purpose entity (“the SPE”) and members of the SPE who do not own the project, called nonowner members. AIA Document C197–2008 is intended for use on a project where the parties have formed the SPE utilizing AIA Document C195–2008, Standard Form Single Purpose Entity Agreement for IPD. C197–2008 is coordinated with C195–2008 to implement the principles of IPD, including the accomplishment of mutually agreed goals. All members of the SPE, other than the project owner, will execute C197–2008.

AIA Document C197–2008 provides the terms under which the non-owner members provide services to the SPE to complete the design and construction of the project. The specific services the nonowner members are required to perform are set forth in the Integrated Scope of Services Matrix, which is part of the C195–2008 Target Cost Amendment and is incorporated into the executed C197–2008. In exchange for the nonowner members’ services, the nonowner members are paid the direct and indirect costs they incur in providing services. Additionally, C197 allows for the nonowner members to receive profit through incentive compensation and goal achievement compensation.

C198–2010, Standard Form of Agreement Between Single Purpose Entity and Consultant for Integrated Project Delivery

AIA Document C198–2010 is a standard form of agreement between a single purpose entity (“the SPE”) and a consultant. AIA Document C198–2010 is intended for use on a project where the parties have formed the SPE utilizing AIA Document C195–2008, Standard Form Single Purpose Entity Agreement for IPD. C198–2010 is coordinated with C195–2008 to implement the principles of IPD. The specific services the consultant is required to perform are set forth within the document as well as the Integrated Scope of Services Matrix, which is part of the C195–2008 Target Cost Amendment. In addition to traditional compensation for services, C198–2010 allows for

the consultant to receive additional profit through incentive compensation and goal achievement compensation.

C199–2010, Standard Form of Agreement Between Single Purpose Entity and Contractor for Integrated Project Delivery

AIA Document C199–2010 is a standard form of agreement between a single purpose entity (“the SPE”) and a contractor. AIA Document C199–2010 is intended for use on a project where the parties have formed the SPE utilizing AIA Document C195–2008, Standard Form Single Purpose Entity Agreement for IPD. C199–2010 is intended to be a flexible document. C199 can be used for a contractor that only provides construction services, or it can also be used for a contractor that will provide both preconstruction and construction services. C199 is not intended for use in competitive bidding and relies upon an agreed to contract sum, which can be either a stipulated sum (fixed price) or cost of the work plus a fee, with a GMP. In addition to compensation for the contract sum, C199 allows for the contractor to receive additional profit through incentive compensation and goal achievement compensation.

C401–2007 (formerly C141–1997), Standard Form of Agreement Between Architect and Consultant

AIA Document C401–2007 is a standard form of agreement between the architect and the consultant providing services to the architect. AIA Document C401–2007 is suitable for use with all types of consultants, including consulting architects. This document may be used with a variety of compensation methods. C401–2007 assumes and incorporates by reference a preexisting owner/architect agreement known as the “prime agreement.” AIA Documents B101–2007, B103–2007, B104–2007, B105–2007, and B152–2007 are the documents most frequently used to establish the prime agreement. C401–2007 was modified in 2007 to be shorter and more flexible by “flowing down” the provisions of the prime agreement, except as specifically stated in C401. NOTE: C401–2007 replaces C141–1997 (expired May 2009).

C441–2008, Standard Form of Agreement Between Architect and Consultant for a Design-Build Project

AIA Document C441–2008 establishes the contractual relationship between the architect and a consultant providing services to the architect on a DB project. AIA Document C441–2008 is suitable for use with all types of consultants, including consulting architects and may be used with a variety of compensation methods. C441 assumes and incorporates

by reference a preexisting prime agreement between design-builder and architect. C441–2008 was written to ensure consistency with AIA Document B143–2004, Standard Form of Agreement Between Design-Builder and Architect, and with other documents in the AIA 2004 DB family of documents.

C727–1992, Standard Form of Agreement Between Architect and Consultant for Special Services

AIA Document C727–1992 provides only the terms and conditions of the agreement between the architect and the consultant—the description of services is left entirely to the parties and must be inserted in the agreement or attached in an exhibit. It is often used for planning, feasibility studies, postoccupancy studies, and other services that require specialized descriptions.

14.4.4 D-Series: Miscellaneous Documents

D101–1995, Methods of Calculating Areas and Volumes of Buildings

This document establishes definitions for methods of calculating the architectural area and volume of buildings. AIA Document D101–1995 also covers interstitial space and office, retail, and residential areas.

D200–1995, Project Checklist

The project checklist is a convenient listing of tasks a practitioner may perform on a given project. This checklist will assist the architect in recognizing required tasks and in locating the data necessary to fulfill assigned responsibilities. By providing space for notes on actions taken, assignment of tasks, and time frames for completion, AIA Document D200–1995 may also serve as a permanent record of the owner's, contractor's, and architect's actions and decisions.

D503–2011, Guide for Sustainable Projects, including Agreement Amendments and Supplementary Conditions

AIA Document D503–2011 is not an agreement but is a guide that discusses the roles and responsibilities faced by Owners, Architects, and Contractors on sustainable design and construction projects. D503 also contains model provisions for modifying or supplementing the following AIA Contract Documents: A201–2007, General Conditions of the Contract for Construction; A101–2007, Standard Form of Agreement Between Owner and Contractor where the basis of payment is a Stipulated Sum; and B101–2007, Standard Form of Agreement Between Owner

and Architect. D503 provides model language with explanatory notes to assist users in adapting those documents for use on a sustainable project. A201–2007, A101–2007, and B101–2007, as standard form documents, cannot address all of the unique requirements and risks of sustainable design and construction. Thus, AIA Document D503–2011 is provided to assist users either in modifying those documents, or developing separate supplementary conditions documents to attach to them.

14.4.5 E-Series: Exhibits

E201–2007, Digital Data Protocol Exhibit

AIA Document E201–2007 is not a stand-alone document but must be attached as an exhibit to an existing agreement, such as the AIA Document B101–2007, Standard Form of Agreement Between Owner and Architect, or A101–2007, Agreement Between Owner and Contractor. Its purpose is to establish the procedures the parties agree to follow with respect to the transmission or exchange of digital data, including instruments of service. AIA Document E201–2007 defines digital data as information, communications, drawings, or designs created or stored for a specific project in digital form. E201 does not create a separate license to use digital data, because AIA documents for design or construction, to which E201 would be attached, already include those provisions. Parties not covered under such agreements should consider executing AIA Document C106–2007, Digital Data Licensing Agreement.

E202–2008, Building Information Modeling Protocol Exhibit

AIA Document E202–2008 is a practical tool for managing the use of BIM across a project. It establishes the requirements for model content at five progressive levels of development and the authorized uses of the model content at each level of development. Through a table the parties complete for each project, AIA Document E202–2008 assigns authorship of each model element by project phase. E202 defines the extent to which model users may rely on model content, clarifies model ownership, sets forth BIM standards and file formats, and provides the scope of responsibility for model management from the beginning to the end of the project. Though written primarily to support a project using IPD, E202 may also be used on projects delivered by more traditional methods. E202 is not a stand-alone document but must be attached as an exhibit to an existing agreement for design services, construction, or material. NOTE: E202–2008 is available in AIA Contract Documents software but is not available in print.

14.4.6 G-Series: Contract Administration and Project Management Forms

G601–1994, Request for Proposal—Land Survey

AIA Document G601–1994 allows owners to request proposals from a number of surveyors based on information deemed necessary by the owner and architect. G601–1994 allows owners to create a request for proposal through checking appropriate boxes and filling in project specifics, thus avoiding the costs associated with requesting unnecessary information. G601–1994 may be executed to form the agreement between the owner and the land surveyor once an understanding is reached.

G602–1993, Request for Proposal—Geotechnical Services

Similar in structure and format to AIA Document G601–1994, AIA Document G602–1993 can form the agreement between the owner and the geotechnical engineer. It allows the owner to tailor the proposal request to address the specific needs of the project. In consultation with the architect, the owner establishes the parameters of service required and evaluates submissions based on criteria such as time, cost, and overall responsiveness to the terms set forth in the request for proposal. When an acceptable submission is selected, the owner signs the document in triplicate, returning one copy to the engineer and one to the architect, thus forming the agreement between owner and geotechnical engineer.

G612–2001, Owner’s Instructions to the Architect

AIA Document G612–2001 is a questionnaire, drafted to elicit information from the owner regarding the nature of the construction contract. AIA Document G612–2001 is divided into three parts: Part A relates to contracts, Part B relates to insurance and bonds, and Part C deals with bidding procedures. The order of the parts follows the project’s chronological sequence to match the points in time when the information will be needed. Because many of the items relating to the contract will have some bearing on the development of construction documents, it is important to place Part A in the owner’s hands at the earliest possible phase of the project. The owner’s responses to Part A will lead to a selection of the appropriate delivery method and contract forms, including the general conditions. Part B naturally follows after selection of the general conditions because insurance and bonding information is dependent upon the type of general conditions chosen. Answers to Part C will follow as the contract documents are further developed.

G701–2001, Change Order

AIA Document G701–2001 is for implementing changes in the work agreed to by the owner, contractor, and architect. Execution of a completed AIA Document G701–2001 indicates agreement upon all the terms of the change, including any changes in the contract sum (or GMP) and contract time. The form provides space for the signatures of the owner, architect, and contractor, and for a complete description of the change.

G701S–2001, Change Order, Subcontractor Variation

AIA Document G701S–2001 modifies AIA Document G701–2001 for use by subcontractors. Modifications to G701–2001 are shown as tracked changes revisions—that is, additional material is underlined; deleted material is crossed out. NOTE: G701S–2001 is not available in print but is available in AIA Contract Documents software and on the AIA Documents-on-Demand Website.

G701CMa–1992, Change Order, Construction Manager-Adviser Edition

AIA Document G701CMa–1992 is for implementing changes in the work agreed to by the owner, contractor, CM adviser, and architect. Execution of a completed AIA Document G701–2001 indicates agreement upon all the terms of the change, including any changes in the Contract Sum (or GMP) and Contract Time. It provides space for the signatures of the owner, contractor, CM adviser, and architect, and for a complete description of the change. The major difference between AIA Documents G701CMa–1992 and G701–2001 is that the signature of the CM adviser, along with those of the owner, architect, and contractor, is required to validate the change order.

G702–1992, Application and Certificate for Payment

AIA Documents G702–1992, Application and Certificate for Payment, and G703–1992, Continuation Sheet, provide convenient and complete forms on which the contractor can apply for payment, and the architect can certify that payment is due. The forms require the contractor to show the status of the contract sum to date, including the total dollar amount of the work completed and stored to date, the amount of retainage (if any), the total of previous payments, a summary of change orders, and the amount of current payment requested. AIA Document G703–1992 breaks the contract sum into portions of the work in accordance with a schedule of values prepared by the contractor as required by the general conditions. NOTE: The AIA does not publish a standard schedule of values form.

AIA Document G702–1992 serves as both the contractor’s application and the architect’s certification. Its use can expedite payment and reduce the possibility of error. If the application is properly completed and acceptable to the architect, the architect’s signature certifies to the owner that a payment in the amount indicated is due to the contractor. The form also allows the architect to certify an amount different than the amount applied for, with explanation provided by the architect.

G702S–1992, Application and Certificate for Payment, Subcontractor Variation

AIA Document G702S–1992 modifies AIA Document G702–1992 for use by subcontractors. Modifications to G702–1992 are shown as tracked changes revisions—that is, additional material is underlined; deleted material is crossed out. NOTE: G702S–1992 is not available in print, but is available in AIA Contract Documents software and on the AIA Documents-on-Demand Website.

G703–1992, Continuation Sheet

AIA Documents G702–1992, Application and Certificate for Payment, and G703–1992, Continuation Sheet, provide convenient and complete forms on which the contractor can apply for payment, and the architect can certify that payment is due. The forms require the contractor to show the status of the contract sum to date, including the total dollar amount of the work completed and stored to date, the amount of retainage (if any), the total of previous payments, a summary of change orders, and the amount of current payment requested. AIA Document G703–1992 breaks the contract sum into portions of the work in accordance with a schedule of values prepared by the contractor as required by the general conditions. NOTE: The AIA does not publish a standard schedule of values form.

G703S–1992, Continuation Sheet, Subcontractor Variation

AIA Document G703S–1992 modifies AIA Document G703—1992 for use by subcontractors. Modifications to G703—1992 are shown as tracked changes revisions—that is, additional material is underlined; deleted material is crossed out. NOTE: G701S–1992 is not available in print but is available in AIA Contract Documents software and on the AIA Documents-on-Demand Website.

G704–2000, Certificate of Substantial Completion

AIA Document G704–2000 is a standard form for recording the date of substantial completion of the work or a designated portion thereof. The

contractor prepares a list of items to be completed or corrected, and the architect verifies and amends this list. If the architect finds that the work is substantially complete, the form is prepared for acceptance by the contractor and the owner, and the list of items to be completed or corrected is attached. In AIA Document G704–2000, the parties agree on the time allowed for completion or correction of the items, the date when the owner will occupy the work or designated portion thereof, and a description of responsibilities for maintenance, heat, utilities, and insurance.

G704CMa–1992, Certificate of Substantial Completion, Construction Manager-Adviser Edition

AIA Document G704CMa–1992 serves the same purpose as AIA Document G704–2000, except that this document expands responsibility for certification of substantial completion to include both the architect and the CM.

G704DB–2004, Acknowledgment of Substantial Completion of a Design-Build Project

Because of the nature of DB contracting, the project owner assumes many of the construction contract administration duties performed by the architect in a traditional project. Because there is not an architect to certify substantial completion, AIA Document G704DB–2004 requires the owner to inspect the project to determine whether the work is substantially complete in accordance with the DB documents and to acknowledge the date when it occurs. AIA Document G704DB–2004 is a variation of AIA Document G704–2000 and provides a standard form for the owner to acknowledge the date of substantial completion.

G705–2001 (formerly G805–2001), List of Subcontractors

AIA Document G705–2001 is a form for listing subcontractors and others proposed to be employed on a project as required by the bidding documents. It is to be filled out by the contractor and returned to the architect for submission to the owner. NOTE: AIA Document G705–2001 was renumbered in 2007, but its content remains the same as in AIA Document G805–2001 (expired May 31, 2009).

G706–1994, Contractor’s Affidavit of Payment of Debts and Claims

The contractor submits this affidavit with the final request for payment, stating that all payrolls, bills for materials and equipment, and other indebtedness connected with the work for which the owner might be responsible has been paid or otherwise satisfied. AIA Document G706–1994 requires

the contractor to list any indebtedness or known claims in connection with the construction contract that have not been paid or otherwise satisfied. The contractor may also be required to furnish a lien bond or indemnity bond to protect the owner with respect to each exception.

G706A–1994, Contractor’s Affidavit of Release of Liens

AIA Document G706A–1994 supports AIA Document G706–1994 in the event that the owner requires a sworn statement of the contractor stating that all releases or waivers of liens have been received. In such event, it is normal for the contractor to submit AIA Documents G706–1994 and G706A–1994 along with attached releases or waivers of liens for the contractor, all subcontractors, and others who may have lien rights against the owner’s property. The contractor is required to list any exceptions to the sworn statement provided in G706A–1994 and may be required to furnish to the owner a lien bond or indemnity bond to protect the owner with respect to such exceptions.

G707–1994, Consent of Surety to Final Payment

AIA Document G707–1994 is intended for use as a companion to AIA Document G706–1994, Contractor’s Affidavit of Payment of Debts and Claims, on construction projects where the contractor is required to furnish a bond. By obtaining the surety’s approval of final payment to the contractor and its agreement that final payment will not relieve the surety of any of its obligations, the owner may preserve its rights under the bond.

G707A–1994, Consent of Surety to Final Reduction in or Partial Release of Retainage

This is a standard form for use when a surety company is involved, and the owner/contractor agreement contains a clause whereby retainage is reduced during the course of the construction project. When duly executed, AIA Document G707A–1994 assures the owner that such reduction or partial release of retainage does not relieve the surety of its obligations.

G709–2001, Work Changes Proposal Request

This form is used to obtain price quotations required in the negotiation of change orders. AIA Document G709–2001 is not a change order or a direction to proceed with the work. It is simply a request to the contractor for information related to a proposed change in the construction contract. AIA Document G709–2001 provides a clear and concise means of initiating the process for changes in the work.

G710–1992, Architect’s Supplemental Instructions

AIA Document G710–1992 is used by the architect to issue additional instructions or interpretations or to order minor changes in the work. It is intended to assist the architect in performing its obligations as interpreter of the contract documents in accordance with the owner/architect agreement and the general conditions of the contract for construction. AIA Document G710–1992 should not be used to change the contract sum or contract time. It is intended to help the architect perform its services with respect to minor changes not involving adjustment in the contract sum or contract time. Such minor changes are authorized under Section 7.4 of AIA Document A201–2007.

G711–1972, Architect’s Field Report

The architect’s project representative can use this standard form to maintain a concise record of site visits or, in the case of a full-time project representative, a daily log of construction activities.

G712–1972, Shop Drawing and Sample Record

AIA Document G712–1972 is a standard form by which the architect can log and monitor shop drawings and samples. The form allows the architect to document receipt of the contractor’s submittals, subsequent referrals of the submittals to the architect’s consultants, action taken, and the date returned to the contractor. AIA Document G712–1972 can also serve as a permanent record of the chronology of the submittal process.

G714–2007, Construction Change Directive

AIA Document G714–2007 is a directive for changes in the Work for use where the owner and contractor have not reached an agreement on proposed changes in the contract sum or contract time. AIA Document G714–2007 was developed as a directive for changes in the work which, if not expeditiously implemented, might delay the project. Upon receipt of a completed G714–2007, the contractor must promptly proceed with the change in the work described therein. NOTE: G714–2007 replaces AIA Document G714–2001 (expired May 31, 2009).

G714CMa–1992, Construction Change Directive, Construction Manager-Adviser Edition

AIA Document G714CMa–1992 serves the same purpose as AIA Document G714–2007, except that this document expands responsibility for signing construction change directives to include both the architect and the CM.

G715–1991, Supplemental Attachment for ACORD Certificate of Insurance 25-S

AIA Document G715–1997 is intended for use in adopting ACORD Form 25-S to certify the coverage required of contractors under AIA Document A201–2007, General Conditions of the Contract for Construction. Since the ACORD certificate does not have space to show all the coverages required in AIA Document A201–2007, the Supplemental Attachment form should be completed, signed by the contractor's insurance representative, and attached to the ACORD certificate.

G716–2004, Request for Information (RFI)

AIA Document G716–2004 provides a standard form for an owner, architect, and contractor to request further information from each other during construction. The form asks the requesting party to list the relevant drawing, specification, or submittal reviewed in attempting to find the information. Neither the request nor the response received provides authorization for work that increases the cost or time of the project.

G732–2009 (formerly G702CMA–1992), Application and Certificate for Payment, Construction Manager as Adviser Edition

AIA Document G732–2009 serves the same purposes as AIA Document G702–1992. The standard form AIA Document G703–1992, Continuation Sheet, is appropriate for use with G732–2009. NOTE: G732–2009 replaces AIA Document G702CMA–1992 (expired December 31, 2010).

G736–2009 (formerly G722CMA–1992), Project Application and Project Certificate for Payment, Construction Manager as Adviser Edition

Use AIA Document G736–2009 with AIA Document G737–2009, Summary of Contractors' Applications for Payment. These forms are designed for a project where a CM is employed as an adviser to the owner but not as a constructor, and where multiple contractors have separate, direct agreements with the owner.

Each contractor submits separate AIA Documents G732–2009 and G703–1992, payment application forms, to the CM-adviser, who collects and compiles them to complete G736–2009. AIA Document G737–2009 serves as a summary of the contractors' applications with totals being transferred to AIA Document G736–2009. The CM-adviser can then sign G736, have it notarized, and submit it along with the G737 to the architect. Both the architect and the CM must certify the payment amount. NOTE: G736–2009 replaces AIA Document G722CMA–1992 (expired December 31, 2010).

G737–2009 (formerly G723CMa–1992), Summary of Contractors’ Applications for Payment, Construction Manager as Adviser Edition

Use AIA Document G736–2009 with AIA Document G737–2009, Summary of Contractors’ Applications for Payment. These forms are designed for a project where a CM is employed as an adviser to the owner, but not as a constructor, and where multiple contractors have separate, direct agreements with the owner.

Each contractor submits separate AIA Documents G703–1992 and G732–2009, payment application forms, to the CM–adviser, who collects and compiles them to complete AIA Document G736–2009. AIA Document G737–2009 serves as a summary of the contractors’ applications with totals being transferred to G736. The CM–adviser can then sign G736, have it notarized, and submit it along with the G737 to the architect. Both the architect and the CM must certify the payment amount. NOTE: G737–2009 replaces AIA Document G723CMa–1992 (expired December 31, 2010).

G801–2007 (formerly G605–2000), Notification of Amendment to the Professional Services Agreement

AIA Document G801–2007 is intended to be used by an architect when notifying an owner of a proposed amendment to the AIA’s owner/architect agreements, such as AIA Document B101–2007. NOTE: G801–2007 replaces AIA Document G605–2000 (expired May 31, 2009).

G802–2007 (formerly G606–2000), Amendment to the Professional Services Agreement

AIA Document G802–2007 is intended to be used by an architect when amending the professional services provisions in the AIA’s owner/architect agreements, such as AIA Document B101–2007. NOTE: G802–2007 replaces AIA Document G606–2000 (expired May 31, 2009).

G803–2007 (formerly G607–2000), Amendment to the Consultant Services Agreement

AIA Document G803–2007 is intended for use by an architect or consultant when amending the professional services provisions in the AIA’s architect–consultant agreement, AIA Document C401–2007. NOTE: G803–2007 replaces AIA Document G607–2000 (expired May 31, 2009).

G804–2001, Register of Bid Documents

AIA Document G804–2001 serves as a log for bid documents while they are in the possession of contractors, subcontractors, and suppliers during the bidding process. The form allows tracking by bidder of documents issued,

deposits received, and documents and deposits returned. AIA Document G804–2001 is particularly useful as a single point of reference when parties interested in the project call for information during the bidding process.

G806–2001, Project Parameters Worksheet

AIA Document G806–2001 is an administrative form intended to help maintain a single standard list of project parameters including project objectives, owner's program, project delivery method, legal parameters, and financial parameters.

G807–2001, Project Team Directory

AIA Document G807–2001 is used as a single point of reference for basic information about project team members including the owner, architect's consultants, contractor, and other entities. AIA Document G807–2001 differs from AIA Document G808–2001, Project Data, which contains only data about the project and project site. G807–2001 should be carefully checked against the owner/architect agreement so that specific requirements as to personnel representing the owner and those involved with the architect in providing services are in conformance with the agreement.

G808–2001, Project Data

AIA Document G808–2001 is used for recording information about approvals and zoning and building code issues gathered in the course of providing professional services. AIA Document G808–2001 should be completed piece by piece as a project progresses and periodically reviewed to ensure information relevance. The attached worksheet, AIA Document G808A–2001, Construction Classification Worksheet, can be used to supplement the G808–2001.

G808A–2001, Construction Classification Worksheet

AIA Document G808A–2001, Construction Classification Worksheet, can be used to supplement AIA Document G808–2001, which is used for recording information about approvals and zoning and building code issues gathered in the course of providing professional services. AIA Document G808–2001 should be completed piece by piece as a project progresses and periodically reviewed to ensure information relevance. AIA Document G808A–2001 can help a design team work through the range of code compliance combinations available before choosing a final compliance strategy.

G809–2001, Project Abstract

AIA Document G809–2001 establishes a brief, uniform description of project data to be used in the tabulation of architect marketing information

and firm statistics. The intent is to provide a single sheet summary where information can be sorted, compiled, and summarized to present a firm's experience. Information compiled in AIA Document G809–2001 can support planning for similar projects and answer questions pertaining to past work.

G810–2001, Transmittal Letter

AIA Document G810–2001 allows for the orderly flow of information between parties involved in the design and construction phase of a project. It serves as a written record of the exchange of project information and acts as a checklist reminding the sender to tell the recipient what exactly is being sent, how the material is being sent, and why it is being sent.



14.5 CONSENSUSDOCS CONTRACT DOCUMENTS

ConsensusDOCS publishes a comprehensive catalog of 100+ documents that covers most contract document needs. ConsensusDOCS are the standard contracts written, developed, and endorsed by a diverse coalition of 40 leading associations with members from all stakeholders in the design and construction industry. By fairly allocating risk and incorporating best practices, ConsensusDOCS helps reduce costly claims and contingencies, and lessen adversarial negotiations, thus saving time and money. ConsensusDOCS contracts are continuously updated to keep pace with the latest changes in construction practices and legal updates. From agreements that address issues such as BIM, green construction, or the standardized ConsensusDOCS contracts, developed by a coalition of leading industry experts means you are assured that your projects have an excellent contractual foundation. Moreover, the ConsensusDOCS comprehensive catalog addresses all major project delivery methods and in addition to providing coordinated administrative forms.

ConsensusDOCS contract documents series include (visit website: www.consensudocs.org).

- 200 Series: General Contracting Documents
 - 300 Series: Collaborative Documents
 - 400 Series: DB Documents
 - 500 Series: Construction Management Contracts
 - 700 Series: Subcontracting Documents
 - 800 Series: Program Management Documents
- Future documents scheduled include:
- Time Extension Addendum

Schedule Specification
 Purchase Agreement
 CM at Risk Short Form
 Land Survey Agreement
 Teaming Agreement for DB Projects
 Subcontractor Qualifications
 Joint Venture Agreement
 Joint Venture Agreement for DB
 Federal Design-Builder and Design Professional Agreement
 Subconsultant Agreement Between an Architect and Engineer
 Owner and Geotechnical Consultant Agreement
General Contracting Documents (200 Series) from ConsensusDOCS

website:

ConsensusDOCS 200: Agreement and General Conditions Between Owner and Constructor (Lump Sum)

- **ConsensusDOCS 200.1: Time and Price Impacted Materials**
 Provides a method for establishing the market price of a construction commodity and for calculating a price adjustment for that commodity if it has an extraordinary cost increase or decrease. View 200.1 Guidebook Comments.
- **ConsensusDOCS 200.2: Electronic Communications Protocol Addendum**
 Helps the parties determine acceptable formats and technology for electronic communications, including BIM. This ground-breaking document allows for communications management and consistency throughout the project. View 200.2 Guidebook Comments.
- **ConsensusDOCS 202: Change Order**
 Used to formalize changes in the work and adjustments to contract time and price.
- **ConsensusDOCS 203: Interim Directed Change**
 A unilateral order issued by the Owner in the absence of agreement on price and time for changes in the work.
- **ConsensusDOCS 204: Request for Information**
 Used by Contractors or Subcontractors to request information or instructions.
- **ConsensusDOCS 205: Short Form Agreement Between Owner and Constructor (Lump Sum)**
 This convenient, short form agreement and general conditions document is premised on concepts and language found in ConsensusDOCS 200.

- **ConsensusDOCS 220: Contractor’s Qualification Statement for Engineered Construction**
May be used as a generic prequalification statement or a contract-specific qualification statement. Includes Schedules A–C regarding current/past projects and key personnel.
- **ConsensusDOCS 221: Contractor’s Statement of Qualifications for a Specific Project**
Helps Owners to assess the qualifications of a Contractor. Includes Schedules A–C regarding current/past projects and key personnel.
- **ConsensusDOCS 222: Architect-Engineer’s Statement of Qualifications for a Specific Project**
Helps Owners to assess the qualifications of an Architect-Engineer.
- **ConsensusDOCS 235: Short Form Agreement Between Owner and Contractor (Cost of Work)**
This convenient, short form agreement and general conditions document is premised on concepts and language found in the ConsensusDOCS 510.
- **ConsensusDOCS 240: Agreement Between Owner and Design Professional**
Coordinated for use with ConsensusDOCS 200 series (Owner-Contractor documents), this agreement is used between the Owner and the Architect-Engineer performing a full range of design and administrative services for the project. View 240 Guidebook Comments. View 240 Index.
- **ConsensusDOCS 245: Short Form Agreement Between Owner and Design Professional**
Describes the relationship between the Owner and the Architect-Engineer and places most transaction-specific information at the front and addresses services from schematic design through construction contract administration.
- **ConsensusDOCS 260: Performance Bond**
Developed with the assistance of organizations representing the surety industry, this standardized performance bond form is coordinated for use with ConsensusDOCS 200 and 500 documents.
- **ConsensusDOCS 261: Payment Bond**
Developed with the assistance of organizations representing the surety industry, this standardized payment bond form is coordinated for use with ConsensusDOCS 200 and 500 documents.
- **ConsensusDOCS 262: Bid Bond**
Developed with the assistance of organizations representing the surety industry, this standardized bid bond form is coordinated for use with ConsensusDOCS 200 and 500 documents.

- **ConsensusDOCS 263: Warranty Bond**
Used for the correction of a defect in the Work during a one-year Correction of Work period. Provisions addressing general conditions and Surety obligation are provided in this document.
- **ConsensusDOCS 270: Instructions to Bidders on Private Work**
Used for bid submission and award, it provides information about pre-bid procedure, including obtaining bidding documents and additional information prior to opening of bids and the examination of bidding documents and worksite.
- **ConsensusDOCS 280: Certificate of Substantial Completion**
Establishes the date of substantial completion of the work or a designated portion thereof.
- **ConsensusDOCS 281: Certificate of Final Completion**
Establishes the date of final completion of the work.
- **ConsensusDOCS 290: Guidelines for Obtaining Financial Owner Information**
Helps the Contractor identify the type of information that should be requested of the Owner, and why this information is important.
- **ConsensusDOCS 290.1: Owner Financial Questionnaire**
Contractors and Subcontractors use this form to request specific information about the Owner's legal structure, ownership of the land, construction financing and insurance matters.
- **ConsensusDOCS 291: Application for Payment (Guaranteed Maximum Price (GMP))**
Facilitates the calculation and documentation of progress payments.
- **ConsensusDOCS 292: Application for Payment (Lump Sum)**
Facilitates the calculation and documentation of progress payments.
- **ConsensusDOCS 293: Schedule of Values**
Provides a breakdown of the cost of elements of the work and should be used with the ConsensusDOCS application for payment forms ConsensusDOCS 291 and 292.
- **ConsensusDOCS 907: Equipment Lease**
Offered as either a one-page agreement or two-page general conditions, this lease agreement is accompanied by an instruction sheet on assumptions in the document which may require modification on items in the standard form requiring completion.

Collaborative Documents (300 Series) from ConsensusDOCS website:
ConsensusDOCS 300: Tri-Party Collaborative Agreement

This is the first standard IPD agreement published in the United States. The Owner, Designer, and Constructor all sign the same agreement.

This agreement incorporates Lean principles and is also known as a relational contract. A core team at both the project management and project development levels is created to make consensus-based project decisions to increase project efficiency and results. View 300 Guidebook Comments. | Read “IPD for Public and Private Owners.”

ConsensusDOCS 301: Building Information Modeling (BIM) Addendum

The first standard contract document that globally addresses legal issues and administration associated with utilizing BIM, it is intended to be used as an identical contract addendum for all project participants inputting information into a BIM Model. It also includes a BIM Execution Plan, which allows the parties to determine the level for which BIM model(s) may be relied upon legally. View 301 Guidebook Comments.

ConsensusDOCS 310: Green Building Addendum

Another industry first—appropriate for use on projects with green building elements, particularly those seeking a third-party green building rating certification such as LEED. It provides a contractual mechanism to identify clear objectives and assign roles and responsibilities to achieve green goals. The parties designate a GBF to coordinate or implement identified objectives, which can be a project participant or consultant. It contemplates that such services will be included in the underlying agreement with the project participant or in a separate agreement with a GBF. View 310 Guidebook Comments. | Read an article on ConsensusDOCS 310.

Design-Build Documents (400 Series) from ConsensusDOCS Website:

- **ConsensusDOCS 400: Preliminary Agreement Between Owner and Designer-Builder**

Intended to be used in conjunction with ConsensusDOCS 410 or 415 to take the project through schematic design only.

- **ConsensusDOCS 410: Agreement and General Conditions Between Owner and Design-Builder (Cost of Work Plus Fee with Guaranteed Maximum Price (GMP))**

May be used as a follow-up document to ConsensusDOCS 400 or as a stand-alone document that addresses the entire DB process. View 410 Guidebook Comments.

- **ConsensusDOCS 415: Agreement and General Conditions Between Owner and Design-Builder (Lump Sum Based on the Owner’s Program Including Schematic Design Documents)**

Unlike the ConsensusDOCS 410, this document cannot be used as a stand-alone document to address the entire DB process. It is intended to be a

follow-up document to ConsensusDOCS 400, assuming that the owner's program or other project information includes schematic design documents.

- **ConsensusDOCS 420: Agreement Between Design-Builder and Design Professional**

Delineates the respective rights and responsibilities of the Design-Builder and the Architect-Engineer.

- **ConsensusDOCS 421: Statement of Qualifications**

Provides information to Owners to assess the qualifications of a Designer-Builder.

- **ConsensusDOCS 450: Agreement Between Design-Builder and Subcontractor (Design-Builder Assumes Risk of Owner Payment)**

Intended for use where the Subcontractor has not been retained to provide substantial portions of the design for the project, and payment to the Subcontractor is not conditioned on the Design-Builder having received payment from the Owner.

- **ConsensusDOCS 460: Agreement Between Design-Builder and Design-Build Subcontractor (Subcontractor Provides a Guaranteed Maximum Price (GMP) and Design-Builder Assumes Risk of Owner Payment)**

Intended for use where the Subcontractor is retained by the Design-Builder early in the design phase, basically providing the same design and construction services as the Design-Builder provides the Owner under ConsensusDOCS 410 and 415. Construction is performed based on cost of the work, plus a fee, up to the GMP. Payment to the Subcontractor is not conditioned on the Design-Builder having received payment from the Owner for subcontract work satisfactorily performed.

- **ConsensusDOCS 470: Performance Bond (Surety Is Liable for Design Costs of Work)**

Bond between the Surety and the Designer-Builder where the Surety is liable for the design costs of the work. Provisions addressing Surety obligations, limited liability for design, and dispute resolution are provided in this document. Space is provided to fill in the bond sum and names of Owner (Obligee), Designer-Builder (Principal), Surety, Surety Representative, and Project.

- **ConsensusDOCS 471: Performance Bond (Surety Is Not Liable for Design Services)**

Bond between the Surety and the Designer-Builder where the Surety is not liable for the design costs of the work. Provisions addressing

Surety obligations, on liability of design, and dispute resolution are included.

- **ConsensusDOCS 472: Payment Bond (Surety Is Liable for Design Costs of Work)**

Bond between the Surety and the Designer-Builder where the Surety is liable for the design costs of the work. Provisions addressing Surety obligations, on liability of design, and dispute resolution are included.

- **ConsensusDOCS 473: Payment Bond (Surety Is Not Liable for Design Services)**

Bond between the Surety and the Designer-Builder where the Surety is not liable for the design costs of the work. Provisions addressing Surety obligations, on liability of design, and dispute resolution are included.

- **ConsensusDOCS 481: Certificate of Substantial Completion**

Establishes the date of substantial completion of the work.

- **ConsensusDOCS 482: Certificate of Final Completion**

Establishes the date of final completion of the work.

- **ConsensusDOCS 491: Application for Payment (Cost of Work and a Guaranteed Maximum Price (GMP) Has Been Established)**

Used with the ConsensusDOCS 410 and provides for notarization.

- **ConsensusDOCS 492: Application for Payment (Lump Sum)**

Used with the ConsensusDOCS 415 and provides for notarization.

- **ConsensusDOCS 495: Change Order for Cost-Plus With Guaranteed Maximum Price (GMP) Design-Build Contracts**

Used with the ConsensusDOCS 410 and requires signatures of the Designer-Builder and the Owner.

- **ConsensusDOCS 496: Change Order for Lump Sum Design-Build Contracts**

Used with the ConsensusDOCS 415 and requires signatures of the Designer-Builder and the Owner.

Construction Management Contracts (500 Series) from ConsensusDOCS website:

ConsensusDOCS 500: Agreement and General Conditions Between Owner and Construction Manager (CM is At Risk)

An integrated agreement and general conditions document, the ConsensusDOCS 500 also provides an option for preconstruction services, such as providing estimates of the Project, reviewing drawings and specifications for constructability problems, creating schedules for procurement

of long lead items, and developing Trade Contractor interest in the Project. It may be used in a variety of negotiated contract situations in which the Owner desires a comprehensive set of preconstruction and/or construction services from the Construction Manager and seeks the assurance of an overall project cost ceiling. View 500 Guidebook Comments.

ConsensusDOCS 510: Agreement and General Conditions Between Owner and Construction Manager (Cost of Work with Option for Preconstruction Services)

Intended to form an integrated agreement and general conditions document between the Owner and the CM performing work on a cost of the work plus a fee basis without a GMP. It also provides an option for the Contractor to provide preconstruction services similar to the ConsensusDOCS 500. It may be used in a variety of negotiated contract situations in which the Owner desires a comprehensive set of preconstruction and/or construction services from the Contractor, and it may be particularly applicable in situations where project variables, such as a well-defined scope of the work, may be unknown at the time of contract execution. With preconstruction services added, this document becomes the equivalent of a CM at Risk (CM@R) agreement.

ConsensusDOCS 525: Change Order/Construction Manager Fee Adjustment

This form is for projects built under the Construction Management method of contracting

Subcontracting Documents (700 Series) from ConsensusDOCS website:

- **ConsensusDOCS 703: Purchase Agreement for Noncommodity Goods**
- Standard purchase agreement between a Constructor and an equipment manufacturer for noncommodity goods, which may include some installation labor.
- **ConsensusDOCS 705: Invitation to Bid/Subbid Proposal**
- Used for Subcontractors to describe the scope of work covered in their bids.
- **ConsensusDOCS 706: Performance Bond**
- This bond can be requested by a Contractor from a Subcontractor to guarantee the Subcontractor's performance.
- **ConsensusDOCS 707: Payment Bond**

This bond form can be requested by a Contractor from a Subcontractor to guarantee that the Subcontractor will pay laborers and material suppliers.

- **ConsensusDOCS 710: Application for Payment**
Provides a standardized format for Subcontractor's requests for payment.
- **ConsensusDOCS 721: Statement of Qualifications**
Used by the Subcontractor to provide information, such as personnel qualifications, industry references, performance history, and safety record, to the Contractor who is assessing the Subcontractor's qualifications to work on a specific project.
- **ConsensusDOCS 725: Agreement Between Subcontractor and Subsubcontractor**
The first and only standard agreement, this simplified form, is for use between a Subcontractor and a Subsubcontractor and is suited to the generally less complex relationship between these two parties.
- **Exhibit E**
Insurance requirements to 725 Standard Subsubcontractor Agreement.
- **ConsensusDOCS 750: Agreement Between Contractor and Subcontractor (Contractor Assumes Risk of Owner Payment)**
This document is intended to be generally compatible with ConsensusDOCS 200 or other agreements. An indemnity agreement is also included. View 750 Guidebook Comments.
- **ConsensusDOCS 750.1: Rider Between Contractor and Subcontractor for Material Storage at Subcontractor's Site**
Governs the storage of specific materials and equipment at a Subcontractor's yard and sets a standard agreement for storage that will ensure the minimum precautions and coverages are agreed upon (and purchased if they are not covered in the Builder's Risk Policy for the Project). It may be attached as a rider to ConsensusDOCS 750.
- **ConsensusDOCS 751: Short Form Agreement Between Contractor and Subcontractor (Contractor Assumes Risk of Owner Payment)**
This convenient subcontract form places all negotiated points and project-specific terms at the beginning of the document. The Contractor assumes the risk of Owner nonpayment. An indemnity agreement is also included.
- **ConsensusDOCS 752: Subcontract for Use on Federal Construction**
The first and only standard subcontract agreement for federal projects that is compliant with the contracting requirements and practices found in the 2009 FAR. View 752 Guidebook Comments. | Read an article on ConsensusDOCS 752.

- **ConsensusDOCS 760: Bid or Proposal Bond**
Used when a bid or proposal bond is required.
 - **ConsensusDOCS 781: Certificate of Substantial Completion**
Establishes the date of substantial completion of the work.
 - **ConsensusDOCS 782: Certificate of Final Completion**
Establishes the date of final completion of the work.
 - **ConsensusDOCS 790: Subcontractor Request for Information (RFI)**
Used by Subcontractors to request information or instructions.
 - **ConsensusDOCS 795: Change Order**
Formalizes changes in the work and make adjustment to subcontract time and price.
 - **ConsensusDOCS 796: Interim Directed Change**
A unilateral order issued by the Contractor in absence of agreement on price and time for changes in the Subcontractor's work.
- Program Management Documents (800 Series)** from ConsensusDOCS website:
- **ConsensusDOCS 800: Program Management Agreement and General Conditions Between Owner and Program Manager**
The contractual configuration is of a “pure/agent program manager,” not at risk, either with all design and construction contracts signed by the Owner or the Program Manager signing the contracts as the agent of the Owner. The Program Manager can be seen as replacing the Owner's facilities staff and may oversee a project delivery accomplished under a variety of methods (e.g., DBB or DB) for each discrete project or site. This contract provides a scope of services presented in a matrix to be used as a menu for the parties to assign duties.
 - **ConsensusDOCS 801: Construction Management Agreement Between Owner and Construction Manager (Construction Manager is Owner's Agent and Owner Enters Into All Trade Contractor Agreements)**
 - May be used with the construction management process when the Owner awards all the trade contracts.
 - **ConsensusDOCS 802: Agreement Between Owner and Trade Contractor (Construction Manager is Owner's Agent)**
 - Describes the legal relationship between the Owner and each Trade Contractor, who becomes prime to the Owner. This document is compatible with the ConsensusDOCS 801.

- **ConsensusDOCS 803: Agreement Between Owner and Architect/Engineer (Construction Manager Acting as Agent Has Been Retained by Owner)**
- Developed expressly to coordinate with ConsensusDOCS' other Construction Management agency forms, specifically ConsensusDOCS 801 and 802.
- **ConsensusDOCS 810: Agreement Between Owner and Owner's Representative**
- Agreement between an Owner and a person/entity acting as an Independent Contractor, who shall serve as the Owner's authorized representative for a specific project, assuming that the Owner will retain both an Architect-Engineer and a Contractor.
- **ConsensusDOCS 812: Interim Directed Change**
- Issued by the Owner to the Trade Contractor in the absence of agreement on price and time for changes in the trade contract work.
- **ConsensusDOCS 813: Change Order**
- Used to formalize changes in the trade contract work and make adjustment to time and price.
- **ConsensusDOCS 814: Certificate of Substantial Completion**
- Establishes the date of final completion of the work.
- **ConsensusDOCS 815: Certificate of Final Completion**
- Establishes the date of final completion of the work.



14.6 ENGINEERS JOINT CONTRACT DOCUMENTS COMMITTEE CONTRACT DOCUMENTS

The EJCDC is the third organization that has developed standard documents that represent the latest and best thinking involved in engineering design and construction projects. EJCDC has existed since 1975 to develop and update fair and objective standard documents that are representative of the latest and best thinking in legal relations between the various parties involved in engineering design and construction projects. The EJCDC is a coalition of stakeholders in the project delivery process who develop and endorse quality contract documents. The EJCDC committee is made up of the National Society of Professional Engineers (NSPE), the American Council of Engineering Companies, the American Society of Civil Engineers, and the Associated General Contractors and involves the participation of more than 15 other professional engineering design, construction, owner, legal, and risk management organizations.

EJCDC Contract Documents are therefore systematically prepared, reviewed, and analyzed by various committees of experienced engineering design and construction professionals, owners, contractors, professional liability and risk management experts, with the participation and advice of legal counsel. Furthermore, it is now more than 30 years that EJCDC has been developing and endorsing quality contract documents and encouraging their use through education and promotion (visit: <http://www.ejcdc.org/>).

14.6.1 Engineers Joint Contract Documents Committee Documents: Construction

Standard General Conditions of the Construction Contract (C-700)
Bid Bond; Damages Form (C-435)
Bid Bond; Penal Sum Form (C-430)
Certificate of Substantial Completion (C-625)
Change Order (C-941)
Construction Payment Bond (C-615)
Construction Performance Bond (C-610)
Construction-Related Documents Set (C-990)
Construction-Related Documents Set (C-990)
Contractor's Application for Payment (C-620)
Engineer's Request for Instructions on Bonds and Insurance for Construction (C-051)
Field Order (C-942)
Guide to the Preparation of Supplementary Conditions (C-800)
Narrative Guide to the 2007 EJCDC Construction Documents
Notice of Award, Download (C-510)
Notice to Proceed (C-550)
Owner's Instructions Concerning Bonds and Insurance for Construction (C-052)
Owner's Instructions Regarding Bidding Procedures (C-050)
Suggested Bid Form for Construction Contracts (C-410)
Suggested Form of Agreement Between Owner and Contractor; Cost-Plus (C-525)
Suggested Form of Agreement Between Owner and Contractor; Stipulated Price (C-520)
Suggested Instructions to Bidders for Construction Contracts (C-200)
Work Change Directive (C-940)

14.6.2 Engineers Joint Contract Documents Committee Documents: Contract Document Sets

Owner–Engineer Documents Set, Download (E-990)

Construction–Related Documents Set (C-990)

Design/Build Document Set (D-990)

Engineer–Subconsultant Agreements Set (E-991)

Environmental Remediation Set (R-990)

Full Design/Bid/Build Document Set (A-990)

Owner–Engineer Documents Set (E-990)

Procurement Agreements Set (P-990)

For other EJCDC Documents, visit: <http://www.nspe.org/ejcdc/index.html>. While there are many organizations that produce their own versions of contract documents, it is always advisable to consult an attorney to ensure that a particular contract fully meets your needs.



Green Business Development



15.1 OVERVIEW

Over the past two decades, green building construction has gone from essentially a niche enterprise to a key driver of new business. But the erection of sustainable, profitable green buildings is no longer sufficient to stand out, because today's green buildings are also expected to directly contribute to the health and wellbeing of the people who live and work inside them. Thus, if you are contemplating starting a new construction business, you should certainly consider making it a green construction business, especially since global green building is expected to double by 2018, according to a recent study from Dodge Data & Analytics.

Nevertheless, starting a successful green contracting company is a serious business and does not happen by accident. Like other types of businesses, it requires careful planning to start and succeed. It requires, among other things, the ability to manage the business with all its complexities on a day-to-day basis and taking into account information relating to market analysis, planning, accounting and bookkeeping, advertising, targeting your market, and analyzing the competition, etc. But having said that, companies that are presently embracing green building appear to be among the few businesses in building construction and design that are succeeding. This may be because green buildings generally incorporate nontoxic building materials and products (i.e., green), provide healthier spaces, use recycled building components, are more energy efficient, etc.

The deterring factor in all of this is the recent downturn in the U.S. economy and the fact that for a number of years the construction industry was effectively at a standstill. This encouraged a number of professionals who may be at their peak to reevaluate their future prospects and employment strategy and to consider the possibility of becoming their own boss. The obvious concerns that dominated this strategy were over job satisfaction, location and stress, in addition to cash flow, health insurance, and retirement. Moreover, for anyone seriously thinking about starting a new construction business, there are several things that need to be considered prior to making too many

definitive plans. This became more imperative with some green builders being adversely affected by this recent economic recession and dismal construction market, forcing some customers to adapt a tight budget in which owners/developers were feeling less inclined to splurge on “green” materials and products. The good news is that this was offset by numerous incentives for building green such as the American Recovery and Reinvestment Act (ARRA) which offers homeowners tax credits to encourage them to make their residences more energy efficient. Furthermore, there are a number of new directives for the design and construction of greener buildings which combine to create significant opportunities as well as challenges for the construction industry. Over recent years, many new green building codes have come into effect that requires understanding and complying with.

But, independence has many attractions and advantageous not least of all, being your own boss, having flexible hours and having greater control of your own future. Whether as a green general contractor or professional consultant, you or your accountant bill clients for services rendered. If you are new to contracting, you may initially decide to subcontract all or most of the work to other “specialty” contractors (who will typically bill you on a monthly basis). This may reduce the initial overheads, but whether you are new in the contracting business or you are an established contractor with solid loyal clients, concentrating on the basic elements of the business is essential for survival and growth.

Generally speaking, the individual proprietorship is the form of entity employed by most small businesses at start-up. However, a partnership may be the best way to go if additional capital or expertise is needed. But it is important to realize that the freedom that comes through independence often comes with a heavy price tag, not least of which is the initial loss of security. Thus by being independent, one may suddenly breathe an illusion of freedom but the question that soon emerges and needs answering is, where is the next dollar coming from? Family members in particular need to be mentally prepared for the reality of being unemployed as well as the challenges that starting a new business bring to the table.



15.2 THE OFFICE: HOME-BASED VERSUS BRICKS-AND-MORTAR

After taking the various factors into consideration, the determination is made to incorporate, and so the decision must now be made whether to start searching for office space or whether to work from home. This is

a very serious decision that is influenced by many factors such as available resources, whether foot traffic is important, number of staff needed, whether working full-time or part-time, and whether the business will be Web based or not, and so forth. If the business is to be home based, it will require easy and preferably separate access such as a separate walk-out basement. Many competitive start-up businesses are initially home-based which has several advantages, particularly with the new technology now available and which has become part of our culture. Typical examples of this technology is availability of the Internet, instant messaging, video conferencing, and other innovative workflow tools that make effective telecommuting a reality. Moreover, working from home will obviously save much time that would otherwise be spent traveling back and forth from the office. Some of the other upsides of a home-based office include less risk and start-up costs which allow you to test the waters without excessive expenditure. Likewise, you can outsource things like managing accounts, public relations, website management, etc. But there are a number of significant disadvantages related to working from home such as being constantly distracted, particularly with a large family, children, etc. Moreover, meeting clients and subcontractors at home can sometimes be awkward and not present the professional impression desired. Additionally, you need to ensure that adequate parking space is provided and zoning ordinances are not infringed.

Should the decision be made not to work from home, then appropriate office space will be required. The cost of rental space is mainly determined by the size and location of the office being rented. Upon finding a suitable office, a lease should be prepared in the name of the corporation rather than in your personal name; this will minimize liability exposure should the business not succeed. Also, while people can work in a tight space for short periods of time, particularly during the start-up phase of an operation, it will be difficult to maintain productivity and retain employees over longer periods unless they are comfortable and appropriate space is allocated. An additional incentive is to make the office space as “green” as possible. This will also send the right message to visiting clients, etc. that you practice what you preach.

One of the upsides to having a bricks-and-mortar office is that a physical location causes fewer distractions and may even attract walk-in traffic (e.g., by noticing the sign, etc.). It also reflects more professionally on the firm and portrays an air of confidence and efficiency to clients and potential clients. The main downside is a greater risk factor and increased start-up costs. It also requires a greater full-time commitment up front to get the

office ready for business, as well as the need to hire some staff such as a secretary, etc. To minimize travel time, the location of the new business should not be too distant from your residence. Likewise, easily accessible and adequate parking space is always a definite plus, particularly if many visitors and workers are expected. It may be wise to initially avoid taking out a long lease, particularly if there are lingering doubts about the success of the new venture, and just in case the start-up is unsuccessful. It may be possible to initially enter into a month to month rental agreement. However, if you find yourself tied into a long lease, check the agreement to see if there is a sublease clause that allows you to sublease the premises should you decide to close the business.

Prior to preparing to view potential office space, determine what you can comfortably afford and what your budget allocation is (taking into account not only the rent, but also other items such as furniture, utilities, potential staff, etc.). Also, when calculating space needs, make sure you understand the difference between “Gross” square feet and “usable” or “net” square feet. For example, usable square feet typically consists of the area in square feet available for things such as workstations and generally consists of the total or “gross” square feet less areas occupied by lobbies, rest rooms, kitchens, etc. Thus when inspecting a prospective office, you may wish to ensure it meets your current needs and also possibly accommodate potential future expansion. As a potential tenant, you should also check whether the lease is a Net–Net lease requiring you to pay all expenses including utilities, lighting, signs, taxes, insurance, maintenance, garbage collection, etc. and if so, is this acceptable. Space requirements will vary according to individual needs, the allocated budget, and depending on the type and size of the new business. Most new start-ups need less space than well-established ones. Typically new start-ups may require approximately 100 sq.ft. per workstation, which does not include space for aisles, equipment, and other shared areas. Another important consideration is the placing of a professional looking sign at the front door entrance or other prominent location.



15.3 CREATING A SUCCESSFUL BUSINESS PLAN

Most business advisors and experienced entrepreneurs generally agree that it is wise to develop a business plan prior to starting a business and marketing your construction services. A well-structured plan can certainly help you move forward, to take the right decisions, and help make your business successful. The business plan that you will need to put together will basically

consist of a written document describing the business, its objectives and its strategies, as well as the market it is in and its financial forecasts. It will also clearly detail precisely what services are being offered, who are the proposed recipients of these services, who is the competition, and method used to advertise and promote these services during the first year of business and beyond. However, not all business plans are the same, nor need the same level of detail.

It is important to remember when writing a solid business plan to begin by defining the business's mission and vision statement. The mission and vision statement sets the foundation upon which to launch your business. It is difficult to move forward successfully without first defining the proposed business and the ideals under which it operates. You might start by developing a fairly simple plan first and then expand and elaborate it as you prepare to approach bankers or investors. Having a business plan in place is essential as it will help generate interest from potential lenders, prospective employees, and strategic partners. As an operating tool, it can help manage the business and effectively work toward its success.

To getting started, it is possible to develop the plan in several stages that meet your real business needs. In writing the business plan, it should be kept simple, concise and neatly formatted, and preferably in Microsoft Word document with attached or embedded spreadsheets in Microsoft Excel. Fancy graphics, "padding," and flowery language are unnecessary and should be avoided. The U.S. Small Business Administration suggests to include the following in Your Company Description:

- Describe the nature of your business and list the marketplace needs that you are trying to satisfy.
- Explain how your products and services meet these needs.
- List the specific consumers, organizations, or businesses that your company serves or will serve.
- Explain the competitive advantages that you believe will make your business a success such as your location, expert personnel, efficient operations, or ability to bring value to your customers.

Next, you will need to move on to the Market Analysis section of your plan.

It is also possible to use a business planning software package to prepare the business plan, if deemed desirable although it may lack the flexibility to accurately convey all of the features and potential of your new business. However, business planning software has the advantage of offering a logical step-by-step approach and generally formats your business plan for you.

And unless you have sufficient start-up capital to finance setting up the new business on your own (e.g., for signage, office equipment, payroll, rent, utilities, etc.), then you will probably need to deal with bank loans or investors or both, and for that you will require a more extensive business plan.

For new business start-ups in particular, proper planning is one of the keys to its success and its importance cannot be overemphasized. The process of putting together a business plan, including the research and thought put into it even before commencing to writing it, forces one to take a serious, objective, and unemotional overview of the business project in its entirety. The business plan will invariably assist in identifying areas of strengths and weaknesses. But to be truly effective and convincing, a plan must show among other things, the marketing strategy that is to be employed.

The whole idea of having a business plan is to communicate ideas to others while providing the basis for a financial proposal. Research shows that setting up a new business is fraught with difficulties and challenges and that over half of all new businesses fail within the first 10 years. The main cause for failure is essentially lack of planning and lack of adequate financing. As previously mentioned, finding start-up capital for a new business will not be easy which is why owners will initially be expected to use their own funds or a bank loan linked to income or security other than the business such as a home equity loan, or as a last resort, borrowing from friends or relatives. But business plans are designed to serve several functions in addition to securing external funding. For example, it helps in measuring success within the business; for new businesses, it is often used to ensure that the various aspects of running the business have been researched and adequately thought out, thereby avoiding unexpected surprises. However, it must be said that it is typically required by lenders such as banks when applying for financing; it can help convince banks or potential investors that your firm is worthy of receiving financial assistance for the new venture, especially if you can provide a professional looking basic sales and expense forecast, leading to high profits and minimal loss.

The principal components of a business plan are:

Introduction/Executive Summary: Primarily, this will consist of a brief but comprehensive summary of how the company was formed, what type of business it is (e.g., green construction), and the people linked to it.

Mission and Vision: This generally reflects the objectives, aspirations, and direction of the company's business, as well as its expected goals and achievements. A mission statement generally outlines both short-term and long-term goals and strategies.

Management: Even if the new business is a one-person operation, a key ingredient for potential business success is the strength of your management skills. When the business consists of more than one person, describe the management team with short biographies of principals and key personnel that will be instrumental to the business' success. Include each team member's role, background, position and responsibilities, and why they are specifically qualified for their role.

Services offered: Outline in detail the type of services to be offered, e.g., green builder, sustainability consultant, remodeling and alterations, permitting, site preparation, carpentry, concrete foundations, painting, plumbing and utilities installation, exterior renovations, and the market for these services, and how you will fit them into this market. Include drawings, specifications, previous projects executed and anything else that would enhance your presentation. It is also important to highlight any special skills, factors, and qualities that give your firm an edge over the competition.

Financial plan: Here we need to include your financial statements; this is a vital part of the business plan and is critical and condenses the firm's strategies and assumptions into the cost of setting up the new business and the expected profits. This is the section lenders and investors will be most interested in to evaluate the financial prospects of your business. The Financial section should clearly show financial projections for the first few years of business (depending on the lender's requirements) and may contain formal records of your business's financial activities including:

- Written statement of key business assumptions
- A 12-month profit and loss projection
- 1 year cash flow projection
- Income statement
- Projected balance sheet and break-even point
- Personal financial statement of owner
- Report on cash management

Executive Summary: Although the executive summary appears as the first part of the plan, it is not typically written until the whole document is complete. It basically summarizes the most important information and aspects of your business plan and normally does not consist of more than one or two pages. It generally outlines information relating to the services offered by the business, its key people, why there is a need for this company, the current market, the competition, and strategies that will be employed. And after the mission and vision

are prepared, this should be followed by a summary of the “strengths, weaknesses, opportunities, and challenges” of the new business. It is difficult to set goals for a business without first enumerating the business’s strengths and weaknesses and the strengths and weaknesses of your competitors. As lenders and investors are often very busy, they will not normally spend more than a few minutes to review a business plan to decide whether they should read it in detail or move on to another plan. When it is decided to read any part of the business plan, it is typically the executive summary that is read, which is why it is so imperative for it to be both appealing and convincing and to be able to capture the investor’s attention and imagination. The executive summary is therefore considered to be the most important part of the business plan, and it will determine whether or not the remaining pages will be read or not.



15.4 START-UP COSTS, CAPITALIZATION, AND SETTING A BUDGET

Creating a start-up budget is one of the most important tasks a new business owner will take on as it serves as a roadmap for the business. Considerable expenses may be incurred long before you even start operating your business. It is therefore important to estimate these expenses accurately, and then to try and plan where to get the needed capital. Unfortunately, people often underestimate start-up costs and start their business haphazardly and without proper planning. Without adequate funding, it would be almost impossible to establish, operate, and succeed in setting up a new business. Inadequate funding and being “undercapitalized” is one of the primary reasons why many small businesses fail within their first year of operation. Perhaps due to lack of experience, new business owners also frequently fail to include a contingency amount to meet unforeseen expenses, and consequently, fail to secure adequate financing to carry their business through the period before the business reaches a break-even status and starts to show a profit. Most experts recommend that start-up funding should be adequate to cover operating expenses for 6 months to a year to allow the business to find customers and get established, since many new start-ups are likely to end up spending more money than originally planned. However, it is not possible to determine the amount of financing needed, without detailed cost projections in hand. Some experts suggest a two-part process—develop an accurate estimate of your start-up costs, in addition to putting together

a projection of operating expenses for at least the first 6 months of operation. Performing these two exercises will present a clearer overview of the business and help identify potential problems needing rectification, thereby ensuring a business's success.

15.4.1 Start-Up Costs

It is rarely easy to figure out what the start-up costs will be for a new business, mainly because you have a moving target that is easy to underestimate and frequently subject to change. Start-up costs reflect expenses incurred prior to commencing with the business plan, usually before the first month. It is no secret that many new companies incur initial expenses for legal work, logo design, brochures, and other expenses. Using a start-up worksheet to plan initial financing will help gathering the necessary information to set up initial business balances and prepare a preliminary estimate of start-up expenses (Fig. 15.1). Needless to say, estimating the amount of capital needed to start a new business requires a careful analysis of a number of factors. A list would be needed of realistic expenses of one-time costs for opening your doors that would include all needed furniture, fixtures, and equipment. The list would also include but not be limited to the cost, down payment, or cash price of items, or if purchased on an installment plan, the amount of each monthly payment and for each product.

For first year expenses, they should appear in the Profit and Loss statement of the first year, and expenses incurred before that must appear as start-up expenses. Once the initial estimate of cash needed to start your business is determined, it is then possible to calculate how much money is actually available or can be made available to help setup the business, and if this proves inadequate, then the decision must be made on where the remaining money required to set up the business can be found.

15.4.2 Employees and Required Forms

Your accountant should be the first person to consult in matters relating to whether you should hire yourself or others as full- or part-time employees of the company, as you may require registration with the appropriate State Agencies or obtain Workers Compensation Insurance or Unemployment Insurance (or both). Numerous major firms now allow (or prefer) some of their employees to work from home and only come into the office say, once a week or as required. This could be suitable for say, accountants or estimators.

In larger establishments, it takes many hours of hard work to prepare and file the various payroll reports and other necessary governmental forms; this

Start-up Costs Estimates: The first step is to put together a list of realistic expenses of one-time costs for opening your doors. Such a list would include what furniture, fixtures and equipment is needed, as well as the cost, cash price, down payment if purchased on an installment plan and the amount of each monthly or periodic payment. Record them in the costs table below:

Down Payment	\$ _____
Amount of each payment	\$ _____

The furniture, fixtures and equipment required may include such things as desks, moveable partitions, storage shelves, file cabinets, tables, safe, special lighting, and signs.

TYPICAL START-UP COSTS ITEMS TO BE PAID ONLY ONCE:

Furniture, Fixtures, & Equipment:	
Interior decorating	\$ _____
Installation of fixtures and equipment	\$ _____
Starting inventory	\$ _____
Deposits with public utilities	\$ _____
Legal and other professional fees	\$ _____
Licenses and permits	\$ _____
Advertising and opening promotion	\$ _____
Advance on lease	\$ _____
Other miscellaneous cash requirement	\$ _____

TOTAL ESTIMATED CASH NEEDED TO START = \$ _____

ESTIMATED MONTHLY EXPENSES:

Salary of owner-manager	\$ _____
All other salaries and wages	\$ _____
Payroll taxes and expense	\$ _____
Rent or lease	\$ _____
Advertising	\$ _____
Delivery expense	\$ _____
Office Supplies	\$ _____
Telephone	\$ _____
Other utilities	\$ _____
Insurance	\$ _____
Property taxes	\$ _____
Interest expense	\$ _____
Repairs and maintenance	\$ _____
Legal and accounting	\$ _____
Miscellaneous	\$ _____

TOTAL ESTIMATED MONTHLY EXPENSES = \$ _____
Multiply by 4 (4 months) \$ _____
Add: Total Cash needed to start above \$ _____

TOTAL ESTIMATED CASH NEEDED \$ _____

Figure 15.1 An example of a draft start-up worksheet used to produce a preliminary start-up costs estimate and to plan an initial financial strategy for a new business venture.

would put a heavy burden on anyone trying to keep up with the whole enchilada on their own. When the business has grown sufficiently to allow the hiring of qualified employees and/or managers, take the opportunity to do so and hire them. Having qualified and well-trained personnel can significantly improve a company's performance and help expand the company.

But your accountant should be consulted when the decision is made to hire new employees and what type of personnel files will be needed for each person. Typically, the minimum forms needed would include an I-9 form, Internal Revenue Service (IRS) form W-4, and the state equivalent form for employee income tax withholding. If using independent subcontractors, they should sign IRS form W-9. Again, consult with your accountant as to whether or not state law requires subcontractors to be included on the firm's policy.

15.4.3 Office Utilities, Equipment, and Furnishings

These are necessary overheads when leasing a new office. Advance deposits, especially for new businesses are often required when signing up for Power, Gas, Water, and Sewer. Also, once the decision is made to establish your own business and an office has been leased (if you are not working from home), find out when the next issue of the telephone directory is to be published and the deadline for getting listed, so that you can include a display ad in the yellow pages under the classification that best describes the company's services.

Office Equipment

Businesses will invariably differ in the type of equipment they will need but it should be "green" if possible, as this will reflect well on the company. It may also be prudent with a start-up business to preserve cash for inventories or working capital and initially purchase good used fixtures and equipment at a much lesser price. Obtain more than one quote on the equipment you may need. With the recent changes in the income tax laws, you will have to do extra analysis to determine whether a lease program or direct purchase is the best way to proceed. Whether to buy or lease depends on several factors which your account can advise you on. For new companies that want to keep their initial start-up costs to a minimum, it may be smarter to initially lease as much as possible, especially electronic equipment, computers, copiers, printers, telephone systems, and certain other products due to the continuous advances taking place in these fields. All cash down payments for equipment purchased on contract should be appropriately recorded.

Furniture

Whenever possible, let your office furnishings (desks, credenzas, file cabinets, bookcases, chairs, end tables, lamps) be ecofriendly and ensure you record their cost, so that you can deduct these expenses from your tax bill. When paying in cash, enter the full retail price, and if payment is by installments, note the down payment as a start-up cost.

Needed Decorating or Remodeling

If the office you are moving into needs some redecoration, or reconfiguration, make an estimate of what the total cost will be, and try and negotiate with the landlord to pay for it or deduct it from the base rent. Also talk to suppliers with whom you plan to purchase materials and other services, and record these expenses. It is unlikely that you will consider undertaking major work unless you are contemplating leasing for an extended period.

15.4.4 Suppliers

For a new business, many suppliers may be reluctant to ship their goods without some sort of assurance that they will be paid. It may help to have some good credit references which is why it is important to have a rapport with your banker as he can provide acceptable credit references to your suppliers. Identify key suppliers and determine if the supplier needs convincing that you are honest, hard working and that you are in for the long haul and that your business is solid and has a good chance for success. Some suppliers may request you to pay C.O.D. during the early stages of getting started; take this fact into consideration when preparing your financial planning and start-up estimates. Once you have become established with your suppliers, send your financial data to Dun and Bradstreet to be listed in their files. Most American firms recognize Dun and Bradstreet as a very reliable organization for obtaining correct credit information about a registered company.

15.4.5 Internet Service

Upon signing a rental lease, apply for a phone number (also consider an 800 number) and domain name for your new business Internet website (this is discussed later in the chapter). When you get the phone number, look into a yellow page advertisement (or at least listing), and consider whether to be listed in several headings, or just the most appropriate heading for your services (compare what the competition has).

15.4.6 Expense Report

Almost all larger firms have developed standardized digitized expense report forms for their employees so that they can request reimbursement for their business expenses. Even with a new start-up business, it is vital to monitor expenditure, and a standard form may be the best way to do so as it makes it easier for bookkeeping (Fig. 15.2). Where the expense form is not standardized, it should, nevertheless, be neatly typed and organized, identifying each

ABC GREEN BUILDER INTERNATIONAL WEEKLY EXPENSE REPORT

NAME : John Doe DEPARTMENT: _____ PERIOD: _____ To: _____

DATE & DAY OF WEEK	PROJECT NAME	PROJECT NUMBER	CITY STATE	LODGING	TRANSPORTATION				MEALS			MISC. EXPENSES Itemized Below	DAILY TOTALS
					AIR, RAIL, ETC	RENTAL CAR, LIMO	TAXI, TOLLS, BUS	AUTO EXPENSES Itemized Below	Breakfast	Lunch	Dinner		
SATURDAY													\$0.00
SUNDAY 01-14-16													\$0.00
MONDAY 01-15-16													\$0.00
TUESDAY 01-16-16													\$0.00
WEDNESDAY 01-17-16													\$0.00
THURSDAY 01-18-16													\$0.00
FRIDAY 01-19-16													\$0.00
WEEKLY CATEGORY TOTALS				\$0.00	\$0.00	\$0.00	\$0.00	\$0.00	\$0.00	\$0.00	\$0.00	\$0.00	\$0.00

ITEMIZED ENTERTAINMENT AND BUSINESS MEALS				
DATE	PROJECT	TIME	PLACE & REASON	AMOUNT

SIGNATURE DATE

APPROVED DATE

CHECKED BY ACCOUNTING DATE

ITEMIZED AUTOMOBILE EXPENSES		
DATE	MILEAGE, GAS, PARKING, VIOLATIONS	AMOUNT

ITEMIZED MISCELLANEOUS EXPENSES		
DATE	ITEM & DESCRIPTION	AMOUNT

* Please Include Paid Airfare Under Air, Rail, Etc., Do Not Add To Total Amount.

Figure 15.2 Sample form for a building contractor's weekly expense report.

location, project name and number, and applicable dates with all original receipts and supporting documentation attached in date order. It should then be handed over to accounting to process and record as soon as possible.

15.4.7 Accounting and Bookkeeping

For every type of business, it is important to set up a good accounting and record-keeping system and to learn as much as possible about what taxes your new company is responsible for paying. Company documents and tax and corporate filings are generally required to be kept for 3 years, including: a list of all owners and addresses, copies of all formation documents, financial statements, annual reports, company amendments, or changes.

Being a new business owner, you may decide to do your own record keeping, but if you do, it is advisable to employ the assistance of an accountant to help set up the books based on the simple method outlined below. Moreover, if possible, let the accountant “keep the books” for the first few months until you learn how and feel comfortable taking them over yourself. After a short time, you or an employee will likely be in a position to do the accounting on your own. Whatever the case, use a separate check book and bank account for your business so as to avoid commingling your private and business accounts. Normally, employing records of original entry plus a “General Journal” to record extraneous transactions, as well as a “General Ledger” to which accounts from the three records are posted at the end of each month, will provide the necessary data for a simple “cash” accounting system. This system can be readily converted to an accrual method of accounting by journalizing accounts receivable, payable, accruals, etc. The Balance Sheet and Income statement can be completed fairly easily once these entries are posted.

Consult your accountant regarding issues including preparing the financial statements and reversing the accruals to be equipped for the following month’s entries. It is now possible to enter the gross payroll, payroll deductions, and the net amount in your check register. Where employees are involved, it is expedient to give them a payroll slip itemizing all the facts while maintaining supplementary payroll sheets with all the information as to each employee. Having these individual payroll records and the control accounts in the General Ledger provides you with the necessary information to complete the various payroll tax reports and returns as they become due. At the end of each annual accounting period, all the information for filing your Income Tax returns will be available for your accountant to go through and submit the final returns to the IRS.

Accounting files should preferably be stored on computers (with backups on CDs or portable hard drives) instead of in-file cabinets (this also makes it easier to email and make off-site backup copies when traveling). Reviewing documents onscreen rather than printing them out also helps the environment as does sending emails instead of paper letters. Software like Greenprint is also available and helps eliminate blank pages from documents before printing and can also convert to PDF for paperless document sharing.

15.4.8 Miscellaneous Issues

There are numerous other start-up expenses that need to be taken into consideration when estimating the amount of cash that will be needed when setting up a new business; these include both business and personal living expenses. Thus, if you are leaving a salaried position to start your own business, you need to include in your expense projection an estimate of the costs you and your household will incur for the months it will take to build up your business. At this point, it probably makes sense to review certain categories, such as equipment, office supplies, or advertising/promotions, with cost-control in mind. If it appears that your estimated start-up costs are greater than originally anticipated, it may be time to review and reevaluate your list of projected expenses and decide, for example, if it is more practical to purchase or lease used office equipment or furnishings than buying new. With this in mind, the classified ads may be a good point to start your search. Classified ads can lead you to bankruptcy auctions, house sales, and furniture resellers in addition to individual items in the classified section. To ensure that you are on the right path, do not shy from asking your attorney or accountant for referrals to business owners who have relevant experience in evaluating start-up costs.

Additional information and advice on start-up costs can be found on the U.S. Department of Commerce Minority Business Development Agency (www.mbda.gov). Articles can be found here that discuss the amount of money needed to start a new business. The Website includes helpful checklists and provides referrals to other resources of information. The U.S. Small Business Administration (www.sba.gov) was created specifically to assist and counsel small businesses. Its publication, Small Business Start-up Kit, includes a checklist for calculating start-up costs. The SBA has an Online Women's Business Center at www.onlinewbc.gov which includes a helpful section on evaluating start-up costs for new businesses and starting a contracting business.



15.5 CREATING A CORPORATE IMAGE

As technology continues to dynamically evolve, today's construction industry also continues to be an ever-changing and innovative industry, which is why creating a distinct corporate image is absolutely vital for the success of corporations in today's market. It is not surprising that every company wants to have a favorable image in the global marketplace. A Corporate Image distinguishes the corporation from its competitors and provides a picture of it to potential customers and the general public. Moreover, building a corporate image is concerned with building confidence and credibility by helping your target audience understand you and your firm better, because it reflects the principles, beliefs, productivity of the company, and increases trust in the company. As discussed earlier in this chapter, starting a new business can be risky but your chances of success significantly increase with proper planning including having a favorable corporate image. Below are some of the steps needed to succeed in setting up a new start-up business venture, whether it is a green contracting business or professional consultancy.

15.5.1 The Corporate Image

It is vital for a new business to create a good corporate image and business identity that reflect confidence and efficiency. Usually, this means hiring a professional designer to design a corporate logo, business card, letterhead, and promotional material for the business. The logo should be simple and not easy to forget; it represents the visual image of your company and will be used in a variety of applications. Moreover, an attractive and professionally created logo and letterhead can go a long way to giving clients the image of confidence and trustworthiness while reducing their perception of risk making it easier to command a premium price for your services. A good logo also says who you are, how you are different from your competition, and why a client should do business with you. The need to have a good logo cannot be overemphasized.

15.5.2 Advertising and Promotion

With any new business, it is important to getting the word out about your business so that customers start coming through your door or your home page. To do this, you will need to research your target audience and develop a marketing message that will resonate with them (Fig. 15.3). Some small new businesses start their operation with a grand opening announcement, in addition to press releases to the local press and relevant business



Figure 15.3 Examples of possible marketing images for new business.

publications. Circulars can be printed and distributed to potential clients or placed in the newspaper to be distributed to subscribers. The dollar cost of planned advertising and marketing initiative announcing the launch of new business should be recorded and reflected in the budget and should include the cost of all promotional items including flyers, brochures, phone calls, and signs. Competition ads should be studied along with their websites.

15.5.3 Marketing Company Services

Prior to marketing your services, adequate research is required to get all the facts just as was done prior to writing the business plan. This will help you formulate a successful marketing strategy that will target your ideal customer and thus be much more methodical and effective. Research will also facilitate in the development of professionally designed brochures and other marketing materials by determining who your target audience is and what their preferences are. As you are selling a specialized service, it is imperative

to know how to market this specialized service. To do this successfully, several key questions need to be answered such as:

- Who the typical customer is?
- Are the services offered what they want?
- What is the budget of targeted customers and how much are they willing to pay? This will obviously vary depending on the project.
- Why should potential customers prefer you over the competition?
- What media type will best reach your target audience and have the best impact?

Upon answering these questions satisfactorily, you will be in position to start developing and implementing a successful marketing strategy. Fig. 15.4 is a typical letter to get the word out and let customers and potential clients know your doors are now open for business.

Time Management

The better organized you are, the more efficient you are and the less time wasted. This can be facilitated by the appointment of a secretary or office manager to deal with the operational aspect of the business and make it as automated and efficient as possible to allow you to concentrate on the business aspects. This will also free you from having to follow up on normal day-to-day issues such as processing orders, paying utility, and other bills, etc.



15.6 TRACK AND IDENTIFY SOURCES FOR LEADS

There are several approaches that can be used to identify potential sources and project leads, depending to some extent on whether your business is essentially a one-person operation or one with several employees. These methods include:

- An excellent starting point would be sending out flyers, brochures, emails, etc. to potential clients and to advertise your services in the local press.
- Check specialized construction search engines like “bidclerk” (www.bidclerk.com), or “buildingonline” (www.buildingonline.com). Check online for others. These sites can provide excellent construction leads for construction projects that are coming up for bid in your area.
- Browse the Internet, particularly real estate broker sites displaying vacant land. All major real estate firms typically have websites, and some of these firms have client lists to build up potential customer confidence on their websites. These lists can be researched to see which if any names are worth following up on. Ask them if it is possible to get information re potential buyers so that you can send them promotional information.

Mr. John Doe
President
XYZ Developers Inc.
1070 East Market St.,
Leesburg, VA 20176

November 24, 2011

(Tel) (703) 777 1234
(Fax) (703) 777 2345
Email: sdoe@XYZ-developers.com

Re: Green Building Services

Dear Mr. Doe:

I am taking this opportunity to apprise you of green building services that we offer to property developers and investors.

ABC Green Building International has recently been formed to provide green construction services. Although ABC is a newly formed company, its principals have over twenty five years of experience in design, construction, and sustainable practices. Our specialty is green construction and we have a number of LEED Accredited Professionals on our staff to ensure improved occupant health, protection of ecosystems, and reducing energy consumption in our projects. For further information and an overview of our services, please view our website at: www.abc-greenbuilding.com. We would be delighted to discuss our services with you and bid on any upcoming projects.

We are able to travel anywhere within the United States to provide services to meet your requirements.

Please take a few days to look things over, and then I'll call you to set-up a time to discuss your requirements.

Sincerely,

Sam Kubba, AIA, RIBA, Ph.D., LEED AP
Principal
ABC GREEN BUILDING INTERNATIONAL

SAK/bs
enclosures

cc: General Files

ABC/PROMO/LETTER/John Doe/ promo.doc

Figure 15.4 An example of a typical promotional letter offering green construction services that can be sent to potential clients to inform them that your company is open and ready for business. Promotional material should accompany the letter.

- Visit neighborhood commercial real estate agents to see what commercial properties including vacant land are currently on the market. Some properties may require renovation. A list of all these possible leads should be made and followed up with letters and brochures offering your company's services.

- Possible leads can normally be found by merely driving around the area or around areas that appear ripe for development. Many of the clients will be lenders (e.g., banks, lending institutions) who will provide financing to property developers or individuals wanting to build a custom home or commercial building (Fig. 15.5). It would be prudent to make a list from the yellow pages, Internet, and from research in the public library of these institutions and send them your promotion material.



Figure 15.5 (a) An office building under construction in Arlington, Virginia. A building sign shows the name of the lending institution and the general contractor. It may be prudent to send promotional mail to the bank to have your firm's name on their contractor list and also a letter to the construction company to seek subcontracting work. (b) Construction underway in Bowie Town Center, Maryland offers opportunities for subcontracting work.



15.7 THE IMPORTANCE OF SELLING YOURSELF

In business, the ability to convince potential clients that you are the best person for the job is critical. You need to make a good impression, be viewed as genuine, and be taken seriously as well. And despite the need to be able to sell yourself to others, for many people it may not come naturally. People are often introverts, shy, or lack self-worth. These are just a few of the obstacles that can potentially get in the way. Dress is another element that can get in your way. To dress for success, you have to “dress” the part. There are several keys to success in dressing and self-presentation. These are discussed below.

15.7.1 Dress for Success

To be successful, it is important to dress appropriately in corporate environments. For example, you do not want to show up in tennis shoes and jeans to an executive meeting, or in a skirt and heels to perform a construction job walk. For general meetings, appropriate dress normally implies for men to wear dress slacks, a clean button up shirt with tie and a blazer or waistcoat. A jacket may not be necessary in some situations like if you are inspecting a building site in summer. And obviously, it is not necessary to wear a business suit when you are working outdoors. However, in the final analysis, this will depend on your own individual situation, environment, and the audience you are dressing for. Another important aspect of proper business attire for a man is to be clean shaven as scruffiness is unprofessional. To further enhance your image and complete your ensemble, hair should be clean and well-groomed and cologne or aftershave should be subtle, not overpowering. If you choose to wear facial hair, it should be closely trimmed and well-groomed.

Wear a conservative watch, and be conservative if you choose to wear other pieces of jewelry. Earrings should normally be removed and any tattoos should normally be covered.

In larger organizations, companies may have a business casual dress code for their employees to follow, whatever that means. Business casual dress is not as formal as wearing professional business clothes—suits are acceptable, but not necessary. It is dressing professionally, but comfortably, and outfits should create a relaxed, comfortable appearance, while still looking neat and smart. Examples of business casual are cotton trousers and khakis for men are generally acceptable. Combine these with a collared shirt, to create a professional, but relaxed appearance. But even businesses with a casual dress

code, you should still dress professionally, especially when having face-to-face meeting with clients or customers.

This also applies to women who become confused sometimes about what is appropriate and what is not. In this, they are not alone as even women in executive positions sometimes admit to not knowing what styles best suit their bodies. Women frequently find themselves wearing clothing that is not of the right size, being either too large or too small, something that can easily be avoided. Furthermore, clothing should not be too revealing. Great basics for most work environment include collared shirts, pencil skirts, and good slacks. If you remain unsure of what to wear to work, observe some of the professional, successful women in your industry as they can offer appropriate examples of what is acceptable in your particular environment (Fig. 15.6a and b). Also, Fig. 15.7 highlights dress policy of one government department.

While proper dress might seem logical and common sense for some, it does not come naturally to everyone. It is a well-known fact that first impressions can significantly impact how a person is ultimately perceived

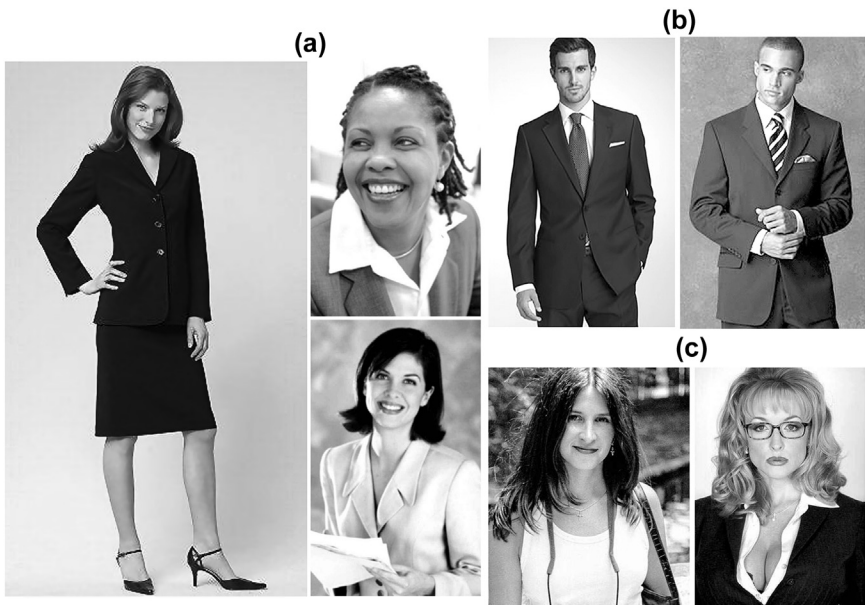

Figure 15.6 Examples of acceptable and unacceptable professional business attire in the office. (a) Three photos showing female appropriate professional business attire. (b) Two photos of appropriate male business attire. (c) Bottom two photos showing inappropriate female professional business attire.

A. POLICY

1. **Generally.** All City employees shall comply with all applicable and appropriate standards of dress, personal appearance, neatness and cleanliness. This policy describes the City's general expectations for employees regarding personal appearance and dress. Department directors are responsible for the enforcement of this policy. All departments shall comply with this policy unless the department has a stricter standard.
2. **Dress Code.** The standard of dress for employees who are not required to wear a uniform is "business casual." The purpose of this standard is to allow employees to work comfortably while at the same time project a professional image. Because not all casual dress is suitable for the office, this policy will set out clothing considered appropriate to wear to work. This is a general overview. Examples of appropriate and inappropriate attire are included. Neither list is all-inclusive; both are subject to change. No dress code can cover all contingencies so employees are required to exercise sound judgment in the choice of clothing to wear to work.
 - a. General Guidelines.
 - i. Clothing should be pressed and never wrinkled (unless the material is wrinkled by design);
 - ii. Seams must be finished;
 - iii. Clothing containing the City of Surprise name and/or logo is encouraged;
 - iv. Torn, dirty, patched, or frayed clothing is unacceptable;
 - v. Clothing containing words, terms, or pictures that may be offensive to other employees and the general public is unacceptable;
 - vi. Clothing that reveals an employee's back, chest, stomach or underwear is unacceptable.
 - b. Examples of Acceptable Business Casual Dress.
 - i. Cotton slacks (similar to Dockers®), wool pants, flannel pants, dressy Capri's, and attractive synthetic dress pants;
 - ii. Casual dresses or skirts (dresses and skirts should be at an appropriate length - mid-thigh or below);
 - iii. Casual shirts, dress shirts, sweaters, tops, golf or polo shirts, and turtlenecks; suit and sport jackets generally;
 - iv. Loafers, clogs, conservative athletic shoes, boots, flats, dress heels, and leather deck-type shoes and sandals are acceptable; closed toe and closed heel shoes are required in certain operational areas;
 - v. Perfume and cologne should be used with restraint, as some people are allergic to chemicals in perfume and make-up.
 - c. Examples of Unacceptable Business Casual Dress.
 - i. Jeans, sweatpants, exercise pants, shorts, bib overalls, leggings, and any spandex or other form-fitting pants;
 - ii. Mini-skirts, skorts, sun dresses, beach dresses, and spaghetti strap dresses;
 - iii. Tank tops, midriff tops, shirts with potentially offensive words, terms, logos, pictures, cartoons, or slogans, halter-tops, tops with bare shoulders, sweatshirts, and t-shirts (unless worn under a blouse, shirt, jacket, or dress);
 - iv. Beach/pool style flip-flops and slippers;
 - v. Hats are not appropriate in the office. Head covers that are required for religious tradition are permitted.
 - d. Casual Days. Fridays, and other days as determined by the department director are declared as "casual" days. On casual days, jeans (clean, non-wrinkled, with finished seams), sweatshirt and t-shirts (that do not contain words, terms, or pictures that may be offensive to other employees and the general public), are permitted in addition to all other acceptable business casual attire.
 - e. Department Directors and Above. While persons in positions of department director and above ("managers") are covered by the City's "business casual" dress code, managers are expected to be attired in "business formal" clothing (suit, jacket and pants, or dress paired with appropriate accessories) for City Council meetings, City Council workshops, formal meetings in the office, and formal events in or outside the office. Managers are expected to know or ascertain all situations when more formal dress is expected and dress accordingly.
3. **Appearance.** The maintenance of high standards of personal cleanliness and appearance by all City employees is essential to creating and maintaining a favorable public image. Employees are expected to observe proper habits of personal grooming and hygiene at all times.
4. **Exceptions.** Exceptions to this policy may be requested and will be granted for bona fide religious and philosophical reasons.

Figure 15.7 Policy on dress guidelines as shown by one government department.

and why proper dress is so important. A person's appearance therefore is a powerful form of communication and when used properly can be an effective tool for portraying confidence, trust, and ability. But regardless of the occasion, dressing appropriately is one of the easiest ways to impress a potential Client. It may not guarantee you getting this job, but it may help you getting the next one. A note of warning, clothing and accessories should not attract so much attention as to distract from a meetings real purpose. Also, when attending a business meeting with a client, bank manager, etc. start off with a firm hand shake and follow up with eye contact.

15.7.2 Introductions

When attending an event where you are likely to meet potential clients e.g., a conference, seminar or even dinner, be sure to carry business cards and perhaps some literature about the company. Also try and portray an air of confidence; this will give you the appearance of an accomplished professional to others. Be cool, calm, and collected, and, most importantly, *think* before you speak. Be organized and prepared and have the necessary knowledge to answer any questions you may be asked, and show customers that you can execute the job successfully.

Correspondence

This is increasingly becoming an online affair which means less paper is being used. Likewise, business files are increasingly being kept on computers instead of in-file cabinets making it easier to make off-site backup copies or take them with you when you move to new offices. Documents can be reviewed onscreen rather than having to print them out. Electronic communication instead of paper letters is far more efficient and cost effective. However, there are various other ways to communicate today such as via telephone, or face-to-face depending largely on one's personality. Introverts tend to prefer email because it is efficient and avoids direct contact; extroverts on the other hand usually prefer direct face-to-face communication. Before sending an email or letter, make sure that it is sent to the correct person. Also, all correspondence should be reviewed for accuracy (a spell check should always be used before transmitting it).

General Meetings

Successful meetings are usually the result of good organization and adequate preparation. It is a time when you will meet clients, investors, executives, and others to discuss relevant topics such as client projects, marketing strategies,

financing, etc. Be prepared with questions and matters you want to cover, and anticipate in advance what your objectives are. During business meetings, be careful to stick to proper meeting etiquette as this is an arena where poor etiquette can reflect negatively on you and your firm. Correct business meeting etiquette automatically improves your chances of success and communicates comfort and trust with everyone involved including colleagues, clients, or customers. In today's business world, it is these people who can greatly impact your firm's ability to succeed and flourish.

Informal Meetings

These are generally more relaxed affairs and may not necessarily take place in the office or meeting room. Nevertheless, a sense of professionalism and good business etiquette are still required. In this respect, punctuality is always important. Also, the purpose of the meeting should be clearly outlined to the proposed attendees. Failing to relay the proper information is poor business etiquette and could cause embarrassment and prevent the meeting from succeeding and achieving its objectives. Normally, the person calling the meeting is the most senior person or the person with the most direct or urgent interest in the topic at hand. This person may also be responsible for determining (through consultation) the meeting's time, place, and agenda. Generally a person is appointed (usually through the chair) to take minutes which can later be typed and distributed to all attendees for future reference.

Formal Meetings

It is unlikely that the owner of a new start-up firm will attend many formal meetings; nevertheless, it is important to have a clear understanding of required etiquette. As a professional, you should dress appropriately and be punctual. Mobile phones should be switched off during the meeting. It is imperative to be well prepared and any reports, or other information that is to be used, should be handed out prior to the meeting (with adequate time to review). If you are unsure regarding the seating pattern, you should ask. During formal meetings, you basically need to:

- When speaking, always address the chair unless it is clear that no one else is doing so.
- When discussions are under way, allow more senior figures to contribute first.
- Acknowledge any opening remarks with a brief recognition of the chair and other participants.

- Refrain from interrupting a speaker—even if you strongly disagree. Note what has been said and come to it when appropriate with the chair's permission.
- It is considered very unethical and a serious breach to divulge confidential information regarding a meeting to others.

Other factors that can add to a new company's chances of achieving success and that should be carefully considered include:

1. **Creating a Network:** Having a good network is almost synonymous with business success. Although a lucrative contract may sometimes be the result of a single contact, it takes a strong network to generate a continuous stream of remunerative projects.
2. **Communication Skills:** Senior and executive-level professionals are expected to have excellent verbal skills, since this competency is a primary determinant for moving up the corporate ladder. However, writing skills can be a major challenge to those who depended on others to put pen to paper especially since consulting and construction projects often require some form of written report. Publishing quality articles that attract the attention of potential clients and the industry is another, cost-effective approach to spread the word. However, face-to-face contact remains the most effective form of communicating and potentially gives the best returns. The down side is that it is time consuming and expensive.
3. **Hard Work:** The chances of a new business succeeding without putting in the hours and the effort are virtually zero. There is obviously some flexibility in the work hours when you become your own boss, but this is no eight-to-five job, and hard work and effort will definitely be needed to build the business. Sometimes a start-up business is lucky and immediately falls into client work and so becomes complacent. Others may find themselves straddling the fence and have not made a wholehearted commitment to the business and continue to look for a suitable position. Not being fully committed prevents you from aggressively building a presence, aggressively marketing your firm's services, aggressively obtaining a Web domain and building a website. Not feeling fully committed is costing you money and ultimately reflects badly on you.
4. **Marketing Skills:** It is necessary to both identify your target market and to develop a detailed marketing strategy that gives you a competitive edge and draws customers to you and your company rather than to the competition. To succeed, you must be willing to engage in relentless self-promotion, to bring in needed new business. Seek out specific

target markets that will need your services and are willing to pay for it. Also develop a list of the main competition in your field and do an honest appraisal of their strengths and weaknesses and how you contemplate successfully competing against them with the available resources.

Grassroots Marketing is another affordable method of marketing. It consists of taking advantage of available resources to spread the word about your service and entails distributing your marketing material at local businesses, churches, chamber of commerce, and community centers. It also includes networking to connect with potential customers and strategic partners and spread the news about your business. Joining a chamber is important as it can facilitate building your network and providing an ecosystem portal to members who may be looking for business, as well as sources of services.

5. **Financial Security:** Being financially secure is key to succeeding at being your own boss in a new business. You must have the ability to survive the dry difficult periods that could easily last a year or more. If survival seems difficult under such circumstances, it may be prudent to reconsider the decision to be an independent business person. If, however, you feel exceptionally strong in one area such as building systems but are very poor in say marketing, it may be possible and wise to team up with others who can compensate for these weaknesses and help you succeed.
6. **People Skills:** Dictating orders to employees within their firm is not the same as dealing with clients which is much more complicated and takes skill. For example, contractors have to respond to a great multitude of personalities with little or no background information on a client's likes and dislikes. Bullying techniques and intimidation that bosses seem to thrive on inside companies fails to get much of a welcoming response from clients and potential customers. Moreover, independent contractors may find themselves quickly dropped if their performance is not up to scratch. While possessing great people skills is a great asset and may bring in the work, it will not necessarily help you retain it or get repeat business; this can only be achieved by hard, persistent effort.
7. **Self direction:** Some people are unable to work on their own initiative and experience great difficulty in performing without the umbrella of a structured environment. Independence can certainly be a freeing and exhilarating experience, but it can also be intimidating and lonely without daily, face-to-face interaction, especially if such individuals have never been their own boss before. This is especially true of those who work out of a home office instead of a rented office space in some corporate office park.



15.8 BUSINESS FORM, LICENSES, PERMITS, AND INSURANCE

Having taken the decision to start a new business, it has become your responsibility to understand and comply with government laws and regulations that apply to your business. Prior to being able to incorporate and register a new firm, there are several bureaucratic and legal hurdles that must be addressed. These laws are designed to protect you, your customer, and your employees. You may now be required to obtain a number of licenses and permits from federal, state, and local government before you can open your doors for business. Licensing and permit requirements for small businesses vary from one jurisdiction to another, so you will need to contact your state and local government to determine which permits, licenses, and other specific obligations are required for your new business. However, before doing so a decision must be made on the proposed name for your new business and the legal structure your new business will be adopting.

15.8.1 Name and Legal Structure

It is always wise to consult an attorney and accountant before deciding on a legal structure, because there is no universally “right” structure for all businesses and choosing the right one for you depends on your specific needs. Since there are advantages and disadvantages for each type of business structure, it is important to understand the various options available to you before setting up your company. There are basically four different forms of business ownership when selecting a legal structure: (1) Sole Proprietorship, (2) Partnership (general or limited), (3) Limited Liability Company (LLC), and (4) Corporation or S-Corporation.

Many small new business owners seem to prefer the sole proprietorship form, perhaps because they are the least complicated and simplest form of business organization to set up. The individual proprietorship business form is basically owned and operated by one person, and apart from local business licenses, there are minimal government fees and paperwork. On the other hand, there are also considerable risks that need to be considered such as the vulnerability to creditors of your personal assets and other liabilities such as lawsuits. In addition, you may not be able to take advantage of certain tax breaks that are reserved for more formal business structures such as Corporations or Limited Liability Companies. Moreover, as a sole proprietorship, your company name is not protected which means that there is nothing

preventing another company from incorporating under your business name. This is why it is wise to work closely with an attorney and avoid many of the potential pitfalls and challenges that setting up a new business may face.

Partnerships and sole proprietorships are similar in that they are easy to set up and maintain and require no government fees or annual state paperwork. This may also be the way to go if you feel you need additional capital or expertise. A disadvantage with a partnership entity is that you and your partners are each held fully responsible for all company debts. Thus if any of the partners defaults on a company loan, creditors can still go after you personally to satisfy the entire loan. This includes your personal bank accounts, property holdings, and other assets. Furthermore, just as with sole proprietorships, your company name is not protected and can be used by any other new or existing business.

The standard for many of today's businesses is incorporating largely because it shields you and the company from personal liability. Thus creditors are prevented from going after your personal assets to make up for any company shortfalls should your business hit hard times. In addition to protection from personal liability, the corporate business structure also offers significant tax savings, company name protection, and increased opportunities for raising capital. If you decide to incorporate, you need to choose to set up your corporation as either a C-Corp or an S-Corp to take advantage of the various tax options that are available (consult with your accountant). However, unlike a sole proprietorship, corporations will require some initial setup fees and perhaps a certain amount of regular maintenance.

Setting up as a C Corporation only makes sense if you have a significant amount of start-up capital and you feel ready for the big time or if you are desirous of selling shares of stock in your business. This is unlikely to apply to the vast majority of new start-ups. A good alternative to this is the S Corporation which avoids the double taxation of a C Corporation. This form provides a tax-efficient way to structure your business if you expect losses in the short term allowing individual shareholders to report losses on their tax returns rather than pay the double taxation of the C Corporation. Prior to making a final determination, consult with an attorney and account and also check with your Secretary of State (most states are now online). It should be noted that running your business as a corporation also has some serious disadvantages especially for the small new business including, strict laws, and higher State Income taxes in some states, in addition to involving increased legal work and heavier accounting and tax reporting requirements. Moreover, closing down a corporation is often more difficult.

Choosing a business structure for many new entrepreneurs basically comes down to liability protection, tax savings, and convenience. This is why many entrepreneurs today prefer forming an LLC since this type of entity requires fewer formalities and less on-going paperwork than corporations while maintaining the same personal liability protection and tax flexibility. Just as with a corporation, the company name is protected, and the company is shielded from creditors and other company liabilities such as lawsuits. Likewise, with an LLC, minimal company records are required to be kept. Many professionals consider the LLC to combine the best aspects of incorporation with the tax advantages of partnership while omitting much of the red tape that accompanies both. In the end, only you can decide what form serves you best.

15.8.2 Federal Employer Identification Number

An Employer Identification Number (EIN) number is a unique nine-digit number assigned by the IRS to business entities operating in the United States for the purposes of identification. The EIN is required for almost all types of businesses and acts as your business identifier on all types of registrations and documents, and most banks would not let you set up a business checking account or apply for a loan without this number. Apply for a federal EIN as soon as possible (if a corporation, upon receiving your corporate charter back). You can do so by going to the IRS Website and download form SS-4. Once this is filled out, call toll-free (866) 816-2065 for your EIN. Once you get the EIN number, download Form 2553 (S-election) if you want to avoid double taxation on your company earnings, and fill it out. It is strongly advised to mail this form via certified mail, return receipt requested, as the IRS sometimes tends to misplace this important tax election, and the burden of proof is solely on you to prove you sent it within the appropriate time. If the number is used for identification rather than employment tax reporting, it is usually called a tax identification number (TIN). Businesses that are considered proprietorships do not need an EIN and in which case the Owner/Operator SSN is used on tax documents. Should you chose to form an LLC, you will need to decide how you prefer to be taxed (e.g., as a sole proprietorship, partnership, S-corporation, or C-corporation), and use IRS Form 8832 to make your decision.

Whatever your business, you will need a fictitious business name permit also called “dba” or “doing business as” permit. In choosing a business name, it is generally a good practice to choose a name that best describes your product or service to make the public better aware of just what your firm has to offer.

You should apply for a fictitious business name with your state or county offices if you plan on going into business under a name other than your own. Banks will also require a certificate or resolution pertaining to your fictitious name at the time you apply for a bank account for your firm.

15.8.3 Licenses and Permits

Now that you have taken the decision to start a new business, the next step to be implemented is to obtain a number of licenses and permits from federal, state, and local government. A contractor must have the appropriate license prior to entering into and performing a construction contract. The purpose is to regulate the industry for the protection of the public, including homeowners, commercial project owners, and even public project owners. Licensing and permit requirements for small businesses may vary from one jurisdiction to another, and so the new business owner must contact state and local government to determine if any specific requirements are in place prior to setting up a new business. Keeping this in mind, below are some of the different federal, state, and local licenses and permits that may be required prior to opening for business. Note that the impact of performing construction work without a proper license varies from one state to another, but in many states an unlicensed contractor cannot enforce a construction contract against a project owner based on statute and case law. However, the expiration of a previously valid license is a common exception to this.

Business Operation License

This license grants the company the authority to do business within that city/county and can be obtained from the city (for a fee) in which the business will be operating from, or from the local county if the business is located outside the city limits. A business license is required by most cities or counties, even when the business operates from home. If you plan to initially run the business from home, you should first carefully investigate the zoning ordinances in your area. Some residential neighborhoods have strict zoning regulations in place that prohibit use of the home for business purposes.

Upon filing a license application, the city planning or zoning department checks to ensure the location is zoned for the intended purpose and that there are sufficient parking spaces to meet codes requirements. If the area is not zoned for your type of business, a variance or conditional-use permit will be needed before permission to operate is granted. This can

normally be achieved by presenting your case before the city's planning commission. Getting a variance is usually quite straight forward as long as you can show the planning commission that your business, in its proposed location, would not adversely impact the neighborhood. However, in many areas, attitudes toward home-based businesses are gradually changing and becoming more supportive, making it less difficult to obtain a variance for the home-based business.

Occupational Licenses

It is often easy to overlook the need for certain licenses and permits prior to opening for business. There are many types of new businesses that will require an occupational license through the State or local licensing agencies. Such businesses include, but are not limited to, real estate brokers, building contractors, those in the engineering profession, electricians, plumbers, insurance agents, and many others. Moreover, in many states and jurisdictions, occupational licenses will not be granted to conduct business unless relevant state examinations are passed. Your state government offices can be contacted to get a list of occupations that require licensing and passing exams or check on the Internet.

Signage Permit

Numerous cities and jurisdictions have sign ordinances that restrict the size, location, and sometimes the lighting and type of sign that can be installed outside a business. To avoid costly mistakes, the regulations will need to be checked to see if any signage restrictions are imposed by your city or county; written approval of the landlord (if renting a house or apartment) should be secured before going to the expense of having a sign designed and installed.

Other Licenses and Permits

Many kinds of interstate activities regarding license and permit requirements are controlled by federal regulations, but in most cases, this is not a cause for concern. However, a few types of businesses do require federal licensing, including investment advisory services. Check with the Federal Trade Commission to see if your business requires a federal license or not. The same types of permits and licenses that are required by cities are typically required by county governments. If your business is outside the city or town's jurisdiction, these permits will apply to you. County regulations are generally not as strict as those of adjoining cities. Localities may have individual variations, or

they may require additional permits or licenses (e.g., Zoning, Fire or Alarm permits), so both the city and county need to be contacted once you have your basic business information, business address, and TIN.

15.8.4 Insurance

Having adequate insurance cannot be overstated especially for general contractors and professionals. This is discussed in greater detail in [Chapter 16](#) (Litigation and Liability Issues). Premiums are usually high, especially for business liability, but no general contractor or consultant can operate with peace of mind without full coverage. There are many types of insurance on the market for businesses, but these are usually packaged as “General Business Insurance” or a “Business Owner’s Policy.” An experienced insurance agent can be helpful to advise you as to the types of insurance you will need and the type of coverage available (e.g., general liability insurance, health insurance, fire, property insurance, burglary, company vehicles, workers compensation, business interruption, and malpractice insurance). It is advisable to seek estimates from two or three different agents. It is also imperative to have adequate liability insurance, and anyone contemplating to offer contracting services is strongly advised to consult with an attorney. If you have employees and plan to offer them health insurance, talk to your agent about the upfront fee and record the premium payment you will need to make before opening your business. Health insurance costs are among the most important concerns facing small business owners today.

15.8.5 Bank Account

You will not be able to open a business account for your firm without a valid TIN, also known as EIN. Once you have this, you can use that number to open a business checking account. Find a bank that is convenient and where you feel comfortable with the bank manager. He or she can be one of your best references as well as a source for advice and help on financial matters. Even if you are not interested in qualifying for a loan yet, banks can provide a numerous other services fundamental to your business that are generally financial in nature. These can include business checking accounts, business credit cards, and even provide a credit reference. Additionally, banks have great contacts in the community and can be an excellent source of business referrals which is why having good relations with your bank manager is of paramount importance. It may also be useful to develop a line of credit, so it will be there should you need it further down the road. Make sure you maintain separate business and personal finances from the beginning, to

avoid comingling and thereby complicating bookkeeping and tax returns. Likewise, you cannot establish a bank account without a Federal ID number or social security number along with your certificate of assumed (fictitious) business name. If you are incorporated, you may be required to provide a copy of the minutes and a corporate resolution authorizing the account. It is also better to visit the bank you wish to open an account with and discuss with the bank manager what their specific requirements are to open a business checking account and to see if you feel comfortable with the bank manager. Bank requirements vary from bank to bank; some banks are fairly simple whereas others are extremely complex. The more important issue here is establishing a rapport and empathy early on with the bank manager and making sure that he understands your potential needs and is willing to give you bank references, etc.



15.9 TAXES, STRATEGIES, AND INCENTIVES

The ultimate goal of a business tax plan is to minimize your business's tax bill, which makes it an important ingredient for a successful business. Whether it is capitalizing on business deductions, Section 179 depreciation, and home office write-offs for the self-employed, tax deductions for business vehicles, business travel, rental property depreciation, or finding other tax-friendly ways to run your business, a good accountant is indispensable to get the best results in applying small business tax deduction strategies. A necessary requirement of all new business start-ups is to submit applications for Federal and State ID numbers and request "Business Start-Up" application forms from the IRS and from the State Tax Commission. After these are sent in, you will be notified of your number and get a packet of information. Following this, you will periodically receive depository forms, quarterly report forms, W-2s, W-4-As, estimated tax forms, and other relevant material.

Depending on the type of entity you form and the size of your new business, you will encounter various payroll expenses such as FICA taxes (Social Security), State Unemployment (SUE) taxes, Federal Unemployment (FUE) taxes, and Workmen's Compensation (WC) and/or State Disability insurance (SDI). If you are a Sole Proprietor business or are a Partnership, you will be required to file and pay Federal estimated tax reports each quarter based on estimated annual income. Partnerships file an annual information return, and each partner's share of profits is included in their individual personal income tax return. Corporations are also required to file for estimated taxes. Your accountant is the person who should be taking care of this.

15.9.1 Tax Deductions and Write-Offs

Maximize what you can deduct according to Section 179 of the IRS Tax Code, and discover what you can write off by knowing what constitutes legitimate business expenses. For this a proficient accountant will be needed to prepare your accounts. Tax consultant David Wetzel says, “Proper planning will result in you getting all the deductions you deserve. Poor planning raise a red flag with the IRS. Sloppy looking returns and indications of poor record keeping will earn you a trip to see your friendly IRS agent.” Below are some possible tax deductions, but these are likely to change from time to time:

- Rent can typically be deducted for a rented office as a business expense. With a home-based office, the business must be located in a separate room within the home. Ideally, it would be located in a walk-out basement with a separate entrance. To claim home office expenses, you need to calculate the square foot percentage of your home office in relation to your home. Then apply this percentage for deductions for utilities, mortgage or rent, insurance, internet service, etc. to arrive at the final deduction.
- Utilities include water, electricity and phones; they can normally be deducted in outside rented offices. With home office settings, it is better to install a second phone line for your business. This is the safest approach to take phone deductions on your business taxes. Check with your accountant for maximum deductions.
- Furniture: The amount that can be deducted for furniture purchase will vary, but you can reportedly now deduct 100% of all office furniture costs without having to depreciate it over several years. Check with your accountant.
- All supplies purchased for your office can be deducted. It is important to keep receipts.
- Website building and maintaining a business website can be written off as a business expense.
- Computer equipment whether new or recently purchased can be deducted 100% without having to depreciate it.
- Computer software purchased for business use is 100% deductible.
- Business Vehicles: Vehicles travel and other expenses can be claimed based on the actual mileage the vehicle used for business. Check with your account to ascertain the mileage rate at the time.
- Entertainment expenses that are legitimately used for client entertainment such as business lunches can be recouped. Check with your accountant.

- Insurance: Small business owners can generally deduct 100% of insurance premiums, providing they do not exceed your business's net profits. Check with your accountant regarding requirements and stipulations.
- Travel, where the "primary reason" for a trip is business related, a sole proprietor, partner or LLC member can write off all transportation costs within the United States. However, no deductions can be made where the primary motivation is not business related, i.e., for a vacation. Nevertheless, by mixing a few vacation days into your business trip, you can legally deduct all your transportation costs, cab fare, etc.



15.10 THE INTERNET AND INTERNET MARKETING

One of the internet's greatest attributes is that it has leveled the playing field when it comes to competing with the large corporations. And not so long ago, having a website for your new business was considered a luxury, whereas today it has become an absolute necessity, so much so that few businesses can thrive without an online component. One reason is that the internet has created enormous marketing opportunities to reach previously unimaginable numbers of people around the globe. The Internet also makes it accessible to people who might not otherwise have access, and with a well-designed site, a small business can project the image and professionalism of a much larger company. A business website has therefore become a high priority not only because is it a great marketing tool, but it also allows you to develop your green building services and to be able to rapidly launch successive marketing campaigns regarding your firm's capabilities. The importance of a website should not be underestimated; it is a specialized tool that enables you to reach many new clients. Even with a small newly created operation, when it comes to benefiting from a website, its size is almost irrelevant, whether your firm is a one-man entity or a 1000-employee corporation; without a website, you are merely losing business to other companies that do have a website. It is also necessary to keep updated the site regularly about the company, its projects, and with what is happening in your field to make modifications to your website as needed.

In today's competitive world, the Internet is considered one of the best ways to generate high-quality new business opportunities due mainly to its ease of use, being fast, able to target the audiences you seek, is affordable and does not sleep. But there is a steep learning curve to successful

internet marketing at both the strategic and tactical levels. What works today may not work tomorrow taking into account the very nature of the internet marketplace. Also, to take full advantage of the Internet means, it should be more than just creating a website and waiting for potential clients to find it. The website should be but one part of an overall Internet marketing strategy. Property developers or persons in search of a green building contractor should be able to quickly find your photo and CV on your website. The CV should at a minimum provide background information and a list of relevant career highlights. A well-thought-out strategy will help guide all the other decisions that will be made over the months and years ahead.

Your business website should be viewed as a platform featuring your services to clients and potential customers around the world. But even before setting up a website, it is imperative to have an email service. This is a high priority for general communication and for sending promotional material; in fact, most clients today consider email availability vital and find it burdensome and inefficient to have to communicate everything by posted mail. When choosing an email address, it should be simple, professional, and preferably reflect the domain name of the website (once the website is established and the domain name registered). The firm's email signature should be provided, which includes complete contact information and an active link to the website. Visitors to a website often prefer to make the first contact via email, either because they prefer keeping it impersonal or because it is easier for them to articulate what they are looking for by email, etc. This is why a "Contact Us" button/page and/or the footer of the home page are typical locations for listing the corporate mailing and email address and other relevant contact information.

15.10.1 Importance of a Website in This Competitive World

With most businesses and organizations, the public now expects them to have a Website—one that can, at the very least, supply basic information about the services offered and a means of getting in contact. A website and the services it can provide are essential for a 21st century business. In fact, today, a website has become nearly as essential as a telephone, fax machine, or printed brochure. Not having one of these tools can put your company at a serious disadvantage. Furthermore, having a website has many advantages such as marketing your company's services to the world. It is important to consider what information you desire potential customers to gather from

visiting your website. For example, a website can inform consumers and end-users on the benefits of green contracting and how it adds to their bottom line. Well-designed websites usually serve a number of functions that include:

- Provide important information about the firm and its services
- Help resolve any outstanding issues customers may have
- Provide downloadable files such as brochures, research, templates, and other information that may be relevant
- Make it easy for the visitors to the site to contact you
- Steer inquiries from potential customers to the website.
- Motivate users to visit the site and return
- Sell construction services and products (e.g., green products) online
- Provide clients and customers with more efficient service
- Helping to recruit staff
- Allowing customer feedback

Having a well-designed company website can be a great asset and bring in great benefits to a firm by providing clients and users with better access to the company and its services. In addition, it can facilitate resolving clients' issues quickly and satisfactorily which allows you to focus more of your time and energy to other pressing issues. The list of potential services that can be offered via a website is quite substantial. Yet builders and professionals sometimes fail to comprehend the proper function of a website and therefore fail to take appropriate decisions regarding its content and form. Thus, taking a "green" website as an example, it can include green construction projects that the firm has executed, green building costs, and other facts and figures, including any awards that the firm may have received, contact information including company email, address, and telephone numbers, etc. The firm's phone number should be displayed prominently on the home page. The website can also include information regarding the firm's mission statement, structure, and responsibilities. The site can also be used to draw attention to upcoming events such as green industry conferences, new products, as well as other time-sensitive information. But whatever it is, the website should concentrate on appealing to your target audience, i.e., clients and potential customers.

In many cases, general contractors also use their websites to communicate with subcontractors, consultants, clients, and other project team members to explain or ask questions regarding bidding guidelines, building schedules, variation orders, etc. Furthermore, they may also provide downloadable forms, building fact sheets, and equipment procedures for field workers or

subcontractors or manufacturers who may access the site remotely from an off-site location. Confidential information can be password-protected so that only authorized individuals can access the information, for example, by “logging in.”

15.10.2 Planning a Website

Perhaps the first clarification required to proceed in building a website is to decide whether to hire a professional to build the website or whether because you are on a tight budget and feel sufficiently competent to do it yourself. Whatever is decided, remember that the website is an important means of communication with your target audience, and thus one of the first steps in planning the website must be to decide on its content. The content should be about what customers need or want, not about the company itself. Ben Seigel, Principal of the Web design firm Versa Studio, says, “Planning is essential for most businesses and organizations. In practice, many people fail to plan their websites. Sometimes the ever-busy, dynamic nature of running a business is to blame; there are so many operational demands that proper time is not allotted to projects. But this often happens because people fail to recognize that planning for the Web is just as important as planning for anything else in a business.” It is important therefore to try and contemplate what potential site visitors will want to know or see featured on the site when logging on and making sure that the image that the site is to convey to visitors actually contributes toward that end. Furthermore, the website should be organized so that prospects can easily identify the firm’s areas of expertise. In this phase, you really need to research your market and determine the main competition and what their main strengths and weaknesses are. Periodic searches of competitors’ websites can prove to be helpful and should include other general contractors and green building websites to examine the types of services being offered to visitors and to see how they are marketing themselves online. It may also be prudent for a new company starting from scratch, to conduct a quick survey to further assist in learning precisely what services may be required.

To get started on building a website for your new business, a number of requirements need to be satisfied; these include:

- Deciding on a domain name (URL—uniform resource locator/Web address) and registering
- Deciding on a Web hosting service
- Finding appropriate Web authoring software or services to design the website

Registering a Domain Name (Web Address) and Setting Up the Website

Prior to setting up a commercial website (as opposed to a personal home page), a name for the company must be decided upon. Once this is determined, a search needs to be conducted to see if that name is available and not taken by someone else. There are numerous companies that let you register a domain name online by using the search tool to ensure that the name you chose is not reserved. Once the name's availability is confirmed, you can register it immediately (for a small fee) and formally make it your Web address. The extension ".com," is most popularly followed by ".net" or ".us" and others because the majority of users are familiar with these. A domain is essentially the name and address of your website, all in one. For example, if your company name is ABC Green Contracting, your web address may be www.ABCgreencontracting.com. Domain registration is inexpensive, and the domain name can usually be registered with the same hosting company that is to provide the webspace (i.e., space on a computer owned by a hosting company). It is usually best to choose a domain name that is simple, easy to remember, is memorable, and best describes the business. Choosing a good domain name is important because it provides extra branding for your site and makes it easier for people to remember the URL.

Web Hosting Service

It is not surprising that most start-up companies are not desirous of owning or investing in a server (a powerful computer that is always online and has the capacity to store the entire firm's website files, as well as the content and operations of its network). It is therefore necessary to find and hire a suitable Web host for this purpose. There are numerous hosting companies that can be found online, but some research is needed to find the one that best serves your needs. A Web host will generally accept your site into its computers and securely store your files and data, while ensuring that it will be available to you and your customers every day, 24/7.

This means that the space provided on the Web for your firm by the hosting company is set up so that whenever someone types your firm's domain name into their browser, they will automatically be connected to your website. The prudent thing to do is to spend some time online researching topics like "domain hosts" to find a host that best meets your particular needs and budget. Of note, green Web hosting providers are popping up more frequently as the ecomovement becomes widespread. Below are a number of possible domain hosts to start the search:

- www.NetworkSolutions.com
- www.greengeeks.com

- www.fatcow.com
- www.justhost.com
- www.supergreenhosting.com
- www.GoDaddy.com
- www.greenteahosting.com

Upon establishing an account with a hosting service, instructions will be provided on how to upload your website onto their server. This is normally achieved using File Transfer Protocol (FTP) utility software. Many hosting services also have file upload options within the control panel you use to help you manage your site. The hosting service chosen should preferably allow you to build your site online using drag-and-drop and fill-in-the-blank templates, which are simple to apply and do not typically require much technical knowledge. Examples of this type of service are offered by Yahoo! Small Business, StartLogic, and ValueWeb.

15.10.3 Website Components and Website Content

The fact that the Internet is constantly evolving requires the administrator to constantly monitor it and to regularly refresh, update, and add new content. This will help increase visibility in the search engines and give customers a reason to continuously come back to your site.

Basic Website Content

The website's principal function should be attracting visitors and converting them into clients using various means including the articulation of services and/or products offered. This is often stated in a mission or vision statement. Since it is unlikely that many, if any, Internet users will actually know you, it is extremely important that what you say on your website captures the visitor's attention, establishes credibility, provokes their interest, and motivates them to action. This presents you with the opportunity to project the kind of image desired in addition to being able to highlight any particular aspect of the organization that you wish to. The most important component here is obviously the target visitor to whose special needs we must cater to and that should be taken into consideration and included in planning and designing the website.

It is obvious that no customer should ever have to work to get the information needed. Therefore employ the minimum needed to enhance your central message and to tell it simply and clearly in an attractive setting. It is also important to ensure that the corporate image you wish to portray on the webpages matches that of the image displayed in other formats and media. Once a theme is decided upon, it is necessary to be consistent and

stick to it. Also unless you are considering hiring a professional designer to manage all the photos and other graphics on your website, you will need a graphic program to do it yourself (except of course if the hosting company has its own tools). However, basic digital photo and graphics editors can be found online for free, although sophisticated top-end programs like Adobe Photoshop can run into hundreds of dollars. The editing software program chosen should be capable of resizing and cropping images; resolving color and contrast issues; set their resolution, which controls how sharp they are on the webpage; and being able to save them using appropriate color modes and formats. Check out the many graphic programs on the market before making a decision on what to purchase.

In today's business environment, creating a company website is not terribly difficult and a basic website can even be built in several hours. For beginners, a simple method that can be used to start building your own website is by downloading a website template that attracts you (using the "Save As" on your browser) and then editing it with a Web editing program. The Internet is full of potentially suitable templates so that you are not simply imitating another site.

It should be emphasized here that it is illegal to copy another company's webpage, but locating a free template online is simple and can be downloaded from the internet. Once this is done, explore your options for upgrading and customization. Your favorite website builder can be used to complete the design and customization, after which you can immediately publish to the Web. There are several popular Web design software that can be used such as: Adobe Dreamweaver, Microsoft Expression Web (replaced FrontPage), and NetObjects Fusion 11. But before making a final decision of what design software to get for your website, make sure it has the ability to design both in HTML and drag-and-drop. It would be wise to do a little research on the software package you are considering purchasing before doing so.

During the process of building the site, check for bugs in the system such as spelling and grammar mistakes. The presence of spelling or text errors reflects negatively on the site owner and administrator. This should be done one page at a time and in a thorough manner. Once a page is error free and everything is working as intended, move on to the next page, repeating the process until the website has been completely checked. Also when checking for bugs, ensure that all the links work, taking users where they are supposed to go. Additionally, page navigation should be kept consistent across the site, and all site pages should be printable.

Fig. 15.8a and b illustrates two examples of designs that can be found on the Internet which have been edited. There are many websites that offer free Web templates as well as design services. In Fig. 15.8a the contracting buttons links are on the left side of the template whereas in Fig. 15.8b (the architecture template), they are on the top of the page. Both can easily navigate you to where you want to go (e.g., to About Us, Projects in Progress, Services Offered, Firm Principals and Qualifications, etc.). The final layout depends largely on personal preference in how the page is composed and designed. However, for a professional looking website it is almost always best to use a professional for the design. The only exception may be where the website owner is proficient in Web design and has significant graphic design background.

Adding New Content

As the firm grows and develops, and with emerging opportunities and challenges, your website will need to keep pace with new content, which may require:

- Adding profiles of new senior staff to the “About Us” page
- Adding new service lines, awards, and anything else of note to the home page with appropriate links
- Adding photos and text regarding newly completed projects (e.g., “Gallery of Completed Projects”)
- Testing for bugs and ensuring that affected pages are optimized for peak performance whenever new content is added website
- Updating all links and site map after changes

15.10.4 Pinpoint Target Audience and Determine Their Interests

Pinpointing a target audience depends very much on the research you have previously conducted and the answers that you have come up with. The primary purpose here is to know your potential clients so well that you answer any questions they might have before they ask, then make it easy for them to “buy” the concepts you are selling. Clients include existing customers and clients, potential clients, people interested in your area of specialty (who may never have heard of you), organizations, individuals, different groups, and so on. If you are a green builder/contractor, your targeted groups might look a little like this:

- Property Owners and Facility Managers
- Lenders



Copyright statement goes here. All rights reserved

Figure 15.8 (a) Example of Contracting Home Page Template which has been edited, free from www.freewebsitetemplates.com showing the link buttons on the upper part of the page. (b) Typical Sample of Architecture Home Page Template from www.freewebsitetemplates.com which has the link buttons on the left of the page.

- Investors
- Designers, Architects, and Engineers
- Subcontractors
- Green product manufacturers

Take into account the need to prioritize. Potential and existing clients need to learn why you are qualified to do what you do, and why your firm can offer a better service than the competition. In fact, your new website will be designed to sell your company's services as no one else can. Thus, if your objective is to promote an image of a sustainable contractor that specializes in green building, then building owners and investors may take a higher priority than general users. This should be reflected in the structure of the site's pages, and the weighting that you give to each aspect in your guidance within the website. Potential clients must also know that you are to be trusted. The majority of viewers may be unfamiliar with your company which is why it is so important to continuously hammer this message home. There are a number of ways to reinforce this message, such as the use of your company logo, university crest, etc. If you have projects that have won an award, make sure everyone who visits the site is aware of this. It is imperative that your viewers feel reassured that your firm is trustworthy and that its information is credible and reliable. It is advisable to place the company logo on every page and in a consistent location (and in the same size) on the page so that whichever page a user visits first, the logo will be proudly displayed.

Convert Site Visitors to Clients

The time available to make a serious impression on a site visitor is very limited (probably 15s or less) before they are gone. And as the window of opportunity to impress and sell your services is quite small, avoid the use of huge flashy graphics that take forever to load because most visitors do not have the patience to wait for them to appear on their screen and will therefore flee. It is also vital that you articulate what your site is for; if you do not know, then you cannot expect your viewers to. It is also vital that you understand your audience so that you can tailor the site to suit their preferences. Likewise, easy and unobstructed navigation through the site is absolutely essential to a successful design. If the path you lay out for your potential customers is twisted and difficult to follow, they will get lost and you may end up losing a potential client. A successful website therefore is not necessarily the most attractive one (although it helps) nor one consisting of the latest Web technology. It does not even rely on the total number of site visitors but rather on how many visitors return and are converted

into clients and how much business the site can generate. Implementing the above will certainly help to push your website to the top of visitors' list of sites to visit when they want information on your topic.

To maintain a successful website, it needs to be continuously refreshed and periodically updated. If the site is not continuously updated, or carries out of date information, it reflects negatively on the firm. Decide on who is to be the Webmaster who will be responsible for updating the site, introduce new content, security issues, and create firewalls, etc. But the real key to long-term business success on the Internet is continuous maintenance of your website to meet the needs of clients and potential customers.

Company Blogs

These have become quite popular in recent years and are usually created to enhance a business website and drive more traffic to it by bolstering its credibility. Blogs are often used to report company and industry events, comment on relevant news stories, and let people know when new products or services are expected. Blogs may also attract professionals inside your industry and possibly calls from the press. Blogs can be housed on or off-site with its own URL. Where it is housed with its own URL, care should be taken not to distract from the main website.

Attracting Traffic

One of the necessary ingredients to succeed is to ensure that potential customers not only know the website exists but that they are able to access it without difficulty. Your business may offer the best products or services on the Web, but it does not mean a thing if potential customers cannot find them. Additionally, the website and email address should be clearly mentioned on all letterheads, brochures, cards, and advertising material. Regular promotional campaigns and strategies are helpful to drive traffic to your website. This is limited only by your creativity, imagination, and having a good marketing strategy.

Registering your site with as many search engines as possible but especially with the leading search engines like Google, Yahoo, Bing, and MSN is an excellent way to get your site noticed. This will help bring your company to the fore whenever users ask these search engines to scan the Internet for your kind of services. This is necessary for the website to succeed, even though it may appear at times to be a very challenging task. It typically takes at least a few months for a website to generate responses and become recognized. This is the time it normally takes the big search engines

to index a new site. But the popularity of a site and the speed at which it becomes popular really depends on how it is promoted and the services being offered. In addition, it is helpful to register with online directories such as GreenSpec Directory to promote your firm. This is another excellent way to increase your online recognition and visibility and drive qualified prospects to your website. It should be noted that many contractor and green associations also maintain online service directories.

Search engines evaluate your site by basically using what is known as a “web crawler” that reads the “meta tags” in the header of your HTML pages. This is why it is very helpful to include on your site a title and description tag, as well as appropriate keywords. One of the concepts employed for high search engine ranking is called “Keyword density,” which basically means that the webpages should include key terms that drive searches. Useful buzz words for green contractors may include terms such as “green,” “green builder,” “sustainable,” “contractor,” and other key industry terms. But being able to drive visitors to your website is not the main objective of a website. The real objective of a website is to be able to convert site visitors to clients, e.g., by making it easy for new prospects to learn about your services and encouraging them to contact you.

15.10.5 Website Security

Security is considered to be one of the most important issues that concern any website. The webmaster needs to be vigilant about the security of your Website and content, your network and your customers’ private information. The webmaster needs to take this into account, creating firewalls, installing the latest internet security software programs, etc. There are many security software programs on the market such as: Security Shield, CA Internet Security, Norton 360, Norton Internet Security, and McAfee. It is also important that whoever is to be responsible for keeping the site up to date must be able to write and update the pages as needed while keeping abreast of new technologies to maintain the site and keep it fresh and interesting.

Last but perhaps not least, the website should adopt a “best practices” approach. Successful business websites are based on doing simple things well, and each of the objectives that have been set for the company website need to be clearly defined. And while there are obviously other things that need thinking through when developing your website, many of these relate more to your own personal objectives than anything else.



Building Green—Litigation and Liability Issues



16.1 GENERAL OVERVIEW

Most state and local governments now have a wide variety of initiatives to inspire and encourage the design and construction of energy efficient “green” design practices. In many cases, projects owned or leased by government authorities are now subject to mandatory green requirements. Private contractors and developers are often encouraged to go “green” through the introduction of contractual or tax-related incentives. Promoters of green building features often tout the cost savings associated with energy-saving features or the increased marketability of a property if it is able to achieve a certain green building certification standard. The majority of liability scenarios in green buildings and sustainable construction, however, differ little from those in regular buildings, and are, therefore, already addressed by existing laws, as courts can apply existing construction law to green building project defects. Nevertheless, green design strategies and systems can present unique new challenges in possible risk and liability that requires to be well understood to minimize the potential for failure or under performance, and litigation that may result from unforeseen problems. We have witnessed in recent years a sharp increase in litigation, many related to green buildings, due partly to the lack of proper preparation to address risk and liability in building projects causing developers to face unforeseen problems in the form of job site interruptions, negative bottom-line impacts, and red tape.

This increasing litigation is forcing the industry to change in a manner that actually has the potential to improve the quality of the constructed project. The dramatic rise in building litigation has also given an increased urgency for finding lawyers, forensic experts, and consultants that specialize in green building and construction. Also, because most green building laws involve some form of incentive for building green, there exists an inherent potential liability for design professionals (architects, engineers, etc.), contractors, and other project participants should the owner not achieve the

promised “green” certification. This newly emerging risk of green building liability for design professionals when a proposed Leadership in Energy and Environmental Design (LEED) project fails to reach the proposed level of certification is very concerning, and perhaps more so because this is a potential liability that often remains uncovered under the standard language of errors and omissions insurance, which excludes guarantees. Additionally, insufficient precedence (although this is changing) means there remains a lack of relevant data available on this issue and the associated risks it implies. This has resulted in deterring some insurers to move quickly to provide a professional liability insurance that deals with this unique issue of green building. It is also therefore not surprising that lawsuits are becoming a major issue to all concerned, although partly due to the skyrocketing costs of traditional litigation, many of the construction disputes tend to be settled before they go to court.

Even though more than two decades of research and litigation and billions of dollars have been lost to insurance claims and lost productivity, issues like SBS, BRI, and IAQ remain prevalent in the commercial buildings sector. Most of these efforts have been reactive, i.e., a problem is reported, its cause identified, and then it is fixed. And while this may be the less expensive, and perhaps most practical solution, it is failing to halt the rising tide of these costly, debilitating and otherwise avertable painful solutions that the owners and industry are experiencing.

Mold-related claims have dramatically increased in recent years, and developers and contractors are increasingly being held responsible for mold-related damages. Ted Bumgardner, VP with San Diego-based construction consultant Gafcon Inc., says, “Mold has grown into a big business.” Building occupants are suing property owners, owners are suing contractors, and contractors are suing design consultants and product manufacturers. Many insurance companies are struggling to find ways to address mold claims and in many cases are now entirely excluding mold from their coverage. The insurance industry is further responding by changing policy language, claims-handling procedures, and loss reserving, while continuing to try and manage the regulators. Some architects and engineers, in an effort to reducing their professional liability, have also started to respond to this problem by eliminating the term “supervision” from their contractual responsibility during construction and replacing it in their contracts with the terms “observation” or “inspection,” which more correctly describes their services.

Green Building projects are generally required to adhere to zoning and building code requirements. Projects that fail to do so can adversely impact

the consultant and expose him/her to multimillion dollar litigation. Many US cities are now mandating the implementation of green building standards through municipal zoning requirements. Boston is the first city in the nation to stipulate this and now has a municipal zoning code that requires that all large-scale projects meet the U.S. Green Building Council's LEED certification standards. The construction industry generally has in recent years had to deal with higher premiums for all types of insurance, but following the World Trade Center attacks of 9/11 those costs have skyrocketed. In fact, legal claims for all types of building envelope failures continue to rise and are typically made against developers, contractors, property management corporations, architects, engineers, building trades, and government authorities among others.

Latest surveys clearly indicate an emergent and increasing demand to making buildings more eco-friendly and energy efficient; in this respect, significant progress has been achieved with the help of government incentives. And although the green building movement is having a major and positive impact on the construction industry as a whole, there are aspects such as the risk of liability and "greenwashing" (misleading environmental benefits of a product or service) that are causing considerable disquiet and which need to be studied and addressed. However, it should be noted that while green buildings are generally more efficient users of energy and materials, resulting in reduced safety factors for the different systems, in some instances, the use of nonstandard materials and systems are employed, which can result in an increased risk of failure of the affected materials or systems incorporated in green buildings. To minimize these risks qualified and experienced design consultants should be employed to ensure that the design process is correctly implemented. Moreover, the advent of BIM technology promises to be a great asset in helping to improve the overall design systems for construction projects and lessen potential risks. In this respect, Ward Hubbell, Founder and President (January 2004–July 2013) of the Green Building Initiative (GBI) says, "One of our most pressing issues is the fact that some buildings designed to be green fail to live up to expectations. And in business, as we all know, where there are failed expectations there are lawsuits. All practices and/or products that could possibly result in a firm's exposure and liability should be clearly identified. The good news is that this period of increased legal action, or the threat thereof, will in fact motivate the kind of clarity and measurement that both reduces liability risks and results in better buildings."

This is why clear and precise documentation is particularly important in rated green buildings to ensure performance goals and that specified

objectives are met. Moreover, careful consideration should also be given to allocating performance responsibility, coordination of obligations, and what the consequences are when the specified result or objectives are not achieved, including unique insurance, indemnity, liability considerations, and consequential damage. But in addition to contractors and subcontractors, design professionals are also highly vulnerable to claims from clients, owners, and users. This vulnerability is partly due to the failure by some consultants, particularly architects and engineers to understand the challenges that professionalism imposes. Design professionals have to confront daily complex legal issues in their practice. Design professionals need to be above reproach in every aspect of dealings with others and in the management of the firm. Moreover, design professionals may need to concentrate more than most professionals on maintaining good relationships with colleagues and coworkers to meet the many potential challenges they will face. This will help minimize claims and also help attract potential clients.

More often than not, litigation is usually the result of a general breakdown in understanding between the parties involved, either in the interpretation of the contract documents or in the practical working communications between the various parties and others on the construction scene. When the conflicting parties are incapable of reaching an agreement the courts become the final resort to resolve the situation and are called upon to decide what was communicated based upon case law. In the construction industry problems and failures are most often the result of defects due to faulty design, gross negligence, or poor execution or else due to deterioration, which is a natural process unless the deterioration is excessive or rapid (Fig. 16.1).

Carl de Stefanis, President of Inspection & Valuation International, Inc. (IVI), a prominent construction consulting and due diligence firm, says that claims against firms providing due diligence services is an increasing concern. De Stefanis states that roughly 80% of the claims are building envelope related including roofs, exterior insulation and finish system (EIFS), windows, masonry, etc. Not far behind are claims relating to building code issues, and in recent years, mold-related claims have also emerged to become a major concern for the insurance industry. Mold litigation has increased dramatically in the last two decades as have the number and size of water-related property claims. Insurance companies are now grappling with the challenges of how to address these issues and some carriers have decided to exclude mold from their coverage entirely (Fig. 16.2).

Acronyms and phrases like IAQ (Indoor Air Quality), IEQ (Indoor Environmental Quality), Sick Building Syndrome (SBS), and Building

COMMON BUILDING DEFECTS

- **Foundation problems that make the home or building unsafe or unihabitable**
- **Defects in concrete areas such as cracks on sidewalks or sagging driveway**
- **Shrinks, cracks, and buckles on flooring**
- **Leaks, cracks, and holes on exterior walls**
- **Defective windows**
- **Peeling, fading, discolored, or water down paint**
- **Plumbing issues and HVAC problems**
- **Unbalanced or defective doors**
- **Structural and interior defects**
- **Interior dampness and mold growth**
- **Squeaking floors, gutter leaks, and other minor yet significant issues**

Figure 16.1 List of common defects found in building construction.

Related Illness (BRI) are now and then being tossed around so arbitrarily that building owners and managers are encouraged to just shrug them off. This is surprising since all indications are that the incidence of commercial buildings with poor IAQ and the corresponding increase in litigation over the consequences of poor IAQ is quite significant. These increases are bound to impact insurance carriers, which pay for many of the costs of health care and those arising from general commercial liability. In cases where an action is brought against a professional such as an architect or engineer, an expert in the same discipline will likely be required to give an opinion as to whether negligence was a factor in the design, execution, or performance of duty. The right expert witness can make the difference between winning and losing a case. However, in the majority of cases, the investigation will involve much more than expert opinion; for example, laboratory and other tests may be recommended and employed to help determine the cause of failure. The role that experts are required to play will therefore vary depending on the case in question.

Legal services involving architectural and engineering experts are invariably required for a variety of issues including structural failure assessments, building envelope investigations, exposure reconstruction, and assessments involving mold growth in buildings and construction defect evaluations.

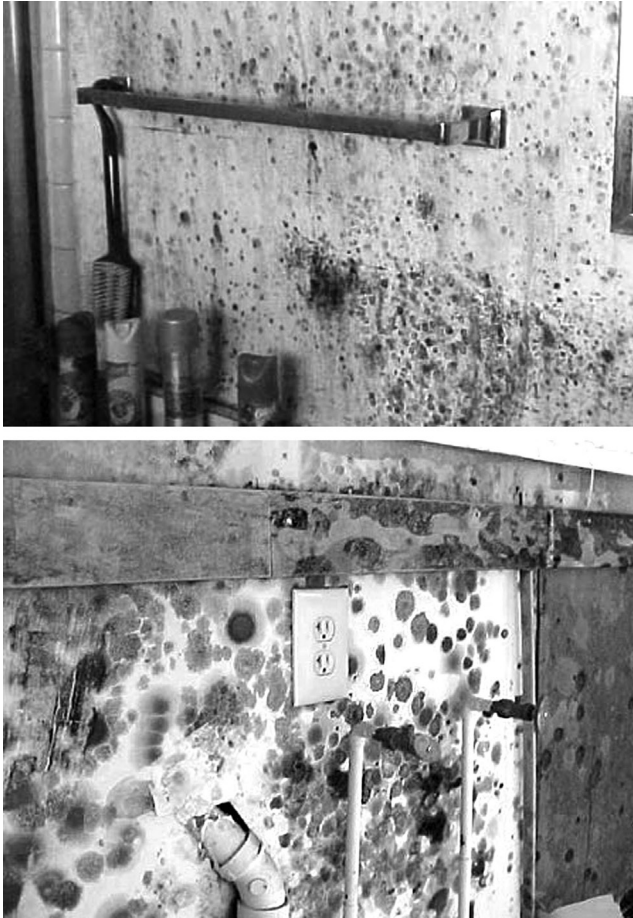

Figure 16.2 Illustrations showing heavy mold infestation caused by water penetration left unattended. Mold litigation has emerged as a major issue in recent years. *Source: Servpro Industries, Inc.*

There are also occasions where consultants may be asked to attempt reconstructing events that took place years ago. The expert consultant's conclusions will typically be used by the client to evaluate a claim's strength, as well as an evidentiary tool in ensuing dispute resolution proceedings. But in addition to consulting and expert testimony services for both defendants and plaintiffs, the expert may be required to perform case evaluations, assist with settlements, and provide advice on litigation avoidance as well as alternative dispute resolution (ADR).

As previously pointed out, it has been found that even in today's litigious environment, the majority of disputes in the construction industry find

resolution before they ever see the inside of a courtroom. Most construction-related disputes are resolved through some form of settlement or ADR, and in various jurisdictions, courts are now making it mandatory for some parties to resort to ADR of some type, usually mediation, before allowing a case to be tried in court. ADR's rising popularity is in part due to the tremendous overload of cases in the courts, and knowing that ADR is usually less expensive than traditional litigation. Added to this is the fact that parties sometimes feel a need to have greater control over the selection of those who will decide their dispute, in addition to the desire for confidentiality in the negotiations.



16.2 LIABILITY-RELATED ISSUES

New technologies such as Building Information Modeling (BIM) is having a serious impact on the responsibilities and interactions of project participants. In fact, over the past two decades, environmental and sustainable design considerations have gone from virtual nonexistent to a driving factor in the design and construction of many of today's projects. The many benefits of pursuing green or sustainable building, design, and construction, in this fast emerging market segment continue to increase its market share of the construction industry. Many owners and developers are embracing these modern technologies, design elements, and operational models even though it brings with its new liability risks. But due to the extreme complexity of these liability issues, it is not possible in this section to adequately address the many concerns and legal matters that may arise with regard to liability topics, and builders, manufacturers, and designers are strongly advised to consult their attorneys and professional liability insurance carriers and agents for advice on these matters. While building owners and managers are rarely expected to guarantee the safety or well-being of their tenants, visitors, and guests, they are required to exercise reasonable care to protect them from foreseeable events. It should also be noted that in recent years, there have been major changes in the civil False Claims Act and how it is enforced. These changes have resulted in increased compliance and enforcement risks for all construction companies conducting business with government agencies, including projects that are funded with government money. This increased concern toward liability issues is be partly due to the enormous upsurge in interest in green buildings, which has resulted in many misconceptions and exaggerations put forth by owners, designers, manufactures, and distributors.

“Greenwashing” is derived from the term “whitewashing”; it may be described as the practice of overpromising or providing false or misleading information on the beneficial green effects proposed products or services will provide. Unfortunately, greenwashing is widespread in the construction industry and appears to be on the rise, impacting both products and services. The problem sometimes comes into play when contractors discover that green products they are seeking are unavailable, creating a delay that can impact their completion date, which induces them to install nongreen products instead. In some instances, contractors have been found to falsely describe themselves as sustainable contractors when they are not (e.g., they are not LEED certified).

Greenwashing can be applied to building materials, systems, buildings, or companies among other things. Indeed, eco-labeling is often found to be unreliable due to a lack of independent validation by third parties. Furthermore, greenwashing has the potential to ultimately discredit the entire green building industry in addition to being the source of numerous lawsuits because the ultimate declared goals of green buildings are not achieved through their use. Greenwashing claims can be categorized into two basic groups: (1) Green materials and products and (2) Green performance related.

16.2.1 Green Material and Products Claims

Because of the lack of preciseness in what constitutes a green building, material or system providers will frequently find a material or product property with limited green characteristics, and often market this property, and the material or product, as being “green.” As an example, a material that uses high recycled content might also contain excessive amounts of urea formaldehyde in its production; thus even though the material’s overall impact on the environment may be negative, this material is nevertheless erroneously marketed as green. Such false claims also frequently occur when material or system providers base their claims on unreliable and inaccurate information. But as green products and the green building industry become better understood and increasingly become part of the mainstream, and as processes such as life cycle analyses are increasingly adopted and become better understood, these risks will begin to decline. In addition, employing reliable material rating systems should also help reduce the plethora of false claims that currently plague the market both in the United States and globally.

16.2.2 Green Performance-Related Claims

A phenomenon that is often cited within the green building industry is the misrepresentation of a person or building stakeholder company’s knowledge

and expertise regarding green building. When building owners and other building stakeholders rely on this professed expertise, the result can be a dismal failure of the green building to achieve its stated goals. In considering a building's operational performance, Ward Hubbell, former President of the GBI notes, "there is an expectation that green buildings will, in addition to reducing environmental impacts, offer lower energy and water costs, less maintenance and other long-term benefits to the building owner. However, while the design may incorporate a wide range of green features, there are, of course, a tremendous number of variables between a building's design and occupancy that can impact operational performance. These potential areas of misunderstanding can be mitigated by following good business practices that facilitate clear communication and common expectations between building owner, designer and rating organizations."

To avoid potential disagreement between building owners, designers, and builders in the interpretation of what constitutes a successful green building, it is extremely important for the building owners and stakeholders to explicitly delineate and communicate their thoughts at the commencement of the project. These issues and problems tend to get compounded when the parties are relatively new and lack an understanding to the concepts of the green building process. This becomes even more unsettling when it is discovered that a lawsuit was recently filed that even challenges the claims of a very prominent green building effort—the LEED certification program. However, a building's failure to achieve a promised level of green building certification can be problematic for the building owner/developer in that it could impact the building's ability to qualify for a tax incentive, or grant on which the owner may have relied on to assist in offsetting the project's initial costs. In the case of public buildings, new laws are emerging that in many jurisdictions now require that public buildings have green certification.

Herbert Leon Macdonell, author of "The Evidence Never Lies" rightly said, "You can lead a jury to the truth, but you can't make them believe it," which is why good field notes and photographs are a necessary imperative as they form the basis of solid documentation. Because field notes provide the first-hand recorded observations of a failure or claim, they are indispensable and irreplaceable. And in addition to being accurate and articulate, they should be written in a manner that is clear, neat, legible, and self-explanatory. Likewise, photographs are usually required to provide a visual record and are cardinal to forensic investigations particularly with issues such as mold, failures, etc. Photographs should be of the highest quality (preferably high-quality digital) and taken from different positions and

viewpoints so as to get a comprehensive overview of the scene in question. Photographs should also be sufficiently annotated and filed appropriately. Digital photographs may be stored on the computer, hard drive, or CD. Whether it is a failure-related or performance-related issue, it may be advisable for the forensic/consultant expert to supplement documentation of the project or scene with video photography. This will depend largely on the circumstances prevailing at the time, the documentation already in hand, and whether deemed necessary for additional clarification.

It is a well-known fact in the construction industry that assigning culpability for green disputes usually boils down to a matter of negligence, ignorance, or incompetence. American courts typically require qualified experts to testify to the standard of care that is applicable to the case in dispute, and also that qualified experts testify to the professional's performance as measured by that applicable standard of care. It should be noted, however, that since building contractors are not legally considered to be "professionals" with respect to making independent evaluations and judgments based on learning and skill, the principle of standard of care may not be applied to them. Builders are nevertheless held to a "Duty to Perform," meaning that the provisions of their contracts require to strictly follow and execute the project plans, specifications, and contract documents (construction contract documents normally consists of four essential documents in combination: (1) Drawings, (2) Specifications, (3) Agreement, and (4) Conditions).

16.2.3 Alternative Dispute Resolution

ADR typically refers to one of several different processes used to resolve disputes between litigating parties. These categories include mediation, arbitration, negotiation, and collaborative law; conciliation and litigation are sometimes considered additional categories. As stated above, courts are increasingly requiring some parties to utilize some type of ADR, most often mediation, before permitting the parties' cases to be heard. In past AIA Agreements the standard dispute resolution provisions called for nonbinding mediation as a condition precedent to binding arbitration. Under the new design-build documents, this requirement of mediation as a condition precedent to other forms of dispute resolution remains, although the new documents now offer the parties from among three methods to choose for dispute resolution. The parties have a choice of picking binding arbitration, litigation, or a third method to be decided by the parties themselves. If the parties fail to choose a binding method of dispute resolution, litigation becomes the selection by default. It should be noted that while the terms

and conditions in the 1996 family of design–build documents incorporated the AIA A201 General Conditions of the Contract for Construction, the AIA documents A141 Agreement between Owner and Design–Builder no longer incorporates the A201 form; it now contains its own general conditions as Exhibit A to the Agreement. The same is true for AIA document A142 Agreement between Design–Builder and Contractor. Although traditionally the Architect served as the Owner’s representative and handled much of the project administration, including the certification of substantial completion of the project, some of these tasks have been taken over by the BIM manager. Likewise, on a design–build project, the administrative functions of the architect, who is part of the design–build team, are significantly different. Recognizing this, the AIA has prepared a new form entitled “G704/db Acknowledgment of Substantial Completion of a Design–Build Project,” which requires the owner to inspect the project and acknowledge the date when substantial completion occurs. This form is a variation of the G704–2000 Certificate of Substantial Completion that was previously used.



16.3 FAILURE, NEGLIGENCE, AND STANDARD OF CARE

Failures are rarely the result of a single cause, but rather most often of interrelated multiple causes. Thus, when an accident or failure takes place, it is important for an investigation team to be put in place, the emphasis and main function being on finding the root cause/s of the failure. Even when all the parties agree that the failure was due to a single technical cause, the responsibility may still elude being accepted as clear-cut especially given the general complexity of today’s project delivery systems. And as new high technology methods of project delivery continue to be introduced, we will witness a corresponding evolution in legal liability interpretation. Liability issues are further complicated and impacted by the fact that architects, engineers, and builders all have obligations to third parties other than those included in the project contracts. In fact, it is usually the third parties that typically are the ones to submit injury and property damage claims in the event of physical, product, or performance failures. Legal responsibility of design professionals clearly extends beyond the party with whom they have contracted to any other party who may be injured by an alleged act of negligence and standard of care.

The most important factors that can impact the legal issues and interests associated with construction failures are as follows: (1) the type of failure, (2) the cause of the failure, and (3) the parties impacted by the failure and their

interests in it. And while each issue is important, the strategy to be employed to effectively represent the party's legal interests should be based mainly on the facts relevant to the failure. These facts can usually be determined through documentation, interviews, and public records, and represent the baseline from which any legal analysis commences. This is one of the reasons why it is so important for the legal and technical teams to be interwoven from the outset of any investigation. It is also important from the outset to determine the ultimate objective for conducting a legal analysis relating to the failure. For example, it could be to determine the cause of the failure, what steps if any should be taken to avoid causing additional harm or damage, and legal responsibility.

Most often in these types of cases, a methodical team approach of both legal and forensic expertise is adopted to help achieve the best possible desired outcome. The overall objectives are interdependent and their individual importance may vary at different points in the investigation progress. Moreover, the legal concerns surrounding a construction failure will vary with the roles and responsibilities of the different parties. The main interest of project owners is in preserving their rights against potentially responsible parties, and in having the project remedied and returned to its prefailure condition, whereas design professionals may be concerned about their legal exposure to injured parties. And although the various parties have different interests, there are a number of actions which the interested parties need to observe and act upon when a failure occurs. The initial steps each party should typically take include the formation of an investigative team; the team will develop a plan of action and deal with public agencies and the media as well as protect confidentiality.

The investigative team elements will depend on a number of factors such as the type and size of the failure in question. Furthermore, the leader of the team should preferably be a senior level member of the client organization who will enjoy the respect and support of the organization. All persons involved in the investigation should take an objective view during the investigation of the cause of failure. The investigative team should include independently retained qualified consultants and experts to assist in the investigation and in the analysis of the various components of the project. Depending on the magnitude and type of failure, additions to the team may include an attorney as lead counsel to assess the viability of legal claims and defenses and one or more forensic experts to study the technical causes of the failure. Likewise, the team should include persons who have personal knowledge of the project, particularly concerning work relating to the failure in question and which may be subject to litigation.

A significant percentage of all major disputes and litigation cases are related to construction failures, which is why when a structural failure does occur, the contractor should be prepared to take action. The first steps following a failure are critical to conducting the investigation as well as to preventing further potential damage or loss of life. Moreover, the actions taken immediately following a failure can have a tremendous impact on the outcome of any subsequent technical investigation. This is because much of the evidence associated with a collapse or structural failure is often of a perishable nature and needs to be preserved and protected. The key factor to avoiding or mitigating the impact of conflicts is having the appropriate mechanisms in place to manage related issues and acting proactively before such issues become issues. An investigation cannot succeed in achieving its objectives to determine the cause of failure and correctly attribute responsibility for the failure if the evidence scene is tampered with because the existing failure scene, condition, and other circumstances on the site become critical evidence. This evidence will play a crucial role in determining the most important factors that may have caused the failure and thus directly impact an investigation's outcome. Moreover, it provides a major element in assisting in the development of hypotheses and theories to the cause of failure, which is why the site should be immediately protected, completely documented, and appropriately recorded. This process can be greatly facilitated if the owner and contractor cooperate with the investigation.

While disputes in the construction industry are fairly common, they are not inevitable and can be prevented with proper care and due diligence.

16.3.1 Procedural Issues

A typical failure is demonstrated by the partial roof collapse in July 2007 of a luxury high-rise building in Greenwood Village, Colorado in which 14 construction workers from Beck Construction and Concrete Express from Dallas, Texas were injured. Rick Palese of Everest Development said that concrete for a flat roof was being poured by Concrete Express onto a metal sheet that sagged and became detached, pinning one person (Fig. 16.3a). The permits show the building is to have 261 units. The plans also call for restaurants, shops, a spa, and a theater. The cause for the failure was under investigation. Beck Residential is the lead contractor on the job. Another terrible structural failure is the Sampoong Department Store collapse. This was a structural failure that occurred on June 29, 1995, in the Seocho-gu district of Seoul, South Korea. The collapse is reportedly the largest peacetime disaster in South Korean history as 502 people died and 937 were injured (Fig. 16.3b).



Figure 16.3a 14 people were injured when a section of the roof of the “The Landmark,” a \$140 million dollar high-rise building collapsed onto the 13th and 12th floors as concrete was being poured for the building’s roof. *Source: CBS Broadcasting Inc.*



Figure 16.3b View of the Sampoong Department store building after its collapse. The building is located in the Seocho-gu district of Seoul, South Korea. There were more than 1500 people in this luxury department store in Seoul, South Korea, when a section of the five-story building collapsed in which more than 500 people were killed. The collapse of the building, which was constructed using steel-reinforced concrete pillars, was blamed on faulty construction.

Document Collection

Compiling of project documents is one of the earliest and top priority actions that need to take place when a failure occurs. The primary sources for these documents are obviously the design and engineering consultants, the contractor(s), and the owner. In addition to the contract documents

(construction drawings: architectural, structural, electrical, etc., and specifications), the principal documents that are typically required to conduct a preliminary evaluation include the following:

- Shop drawings and assembly drawings
- Other contractor submittals
- Change orders, warranties, etc.
- Test reports
- Boring logs
- Construction monitoring photographs and reports
- Engineer of record calculations
- Relevant correspondence.

Interviews

It is important for an investigative team, once it has been commissioned, to investigate the defect, system failure or collapse, appoints a person to be in charge and who immediately makes efforts to conduct interviews with eyewitnesses and other persons such as project personnel who may be able to provide useful information regarding the investigation and which may assist in focusing and determining the probable causes of the failure. It is important to conduct these interviews as soon after a reported incident as possible but especially prior to its “contamination” and while the recollection is still fresh. The specific information that is sought from interviewees depends largely on the type of failure, the circumstances of the failure, and the interviewee’s knowledge and expertise.

Experts Cooperation

It is in the interests of all parties during an investigation for experts to cooperate with each other and with whom there may be common interests. It allows them to pool resources and avoid unnecessary duplication of effort. Other areas of potential collaboration include possible destructive testing, identification of debris and relevant components, as well as the possible sharing of interview information. But while sharing basic information and fostering cooperation are often desirable and may greatly facilitate an investigation, nevertheless, in situations where there is a possibility of litigation, the client or the client’s attorney should always be consulted to ensure that any sharing of information does not inadvertently compromise the client’s interests.

The Preliminary Assessment

From the initial investigation of possible failure scenarios and possible contributing factors, a preliminary evaluation should emerge. Once the input

of the various consultants, eyewitnesses, and staff members are taken into consideration and recorded, there is a need for a follow-up by conducting a preliminary structural analyses and tests to try and determine the viability of initial hypotheses as well as identifying other possibilities that may have triggered the failure such as excessive occupancy loading or by environmental factors (e.g., excessive snow load on roof), strong winds, etc., which exceed the building envelope's design capabilities to withstand such factors.

The expert should fully understand the strategy and objectives of both the client and attorney, before proceeding to offer advice regarding photographs, testing, or measurements, which must be taken as soon as possible to preserve the evidence. The expert must also confer with the client regarding analytical procedures and obtain approval to implement them, and also to identify important documents that will be required. But whatever the case, forensic investigations should be conducted on the assumption that the consultant will be required to offer sworn testimony on the investigation and conclusions reached in a court proceeding. As court procedure rules vary from one jurisdiction to another and it would be prudent for the client's attorney to provide the expert with specific guidance.

Negligence

One of the primary purposes of a construction contract is to allocate risk and define the respective responsibilities of the parties. And lawsuits based on negligence are today considered the most common kind of civil action in the area of tort law. It occurs when a person fails to exercise the standard of care that a reasonable, prudent person would have exercised in a similar circumstance (this is sometimes called a lack of "due care"). Very often the bottom line in assigning culpability for failure issues or construction disputes is narrowed down to a result of negligence, ignorance, or incompetence. In fact, property developers and project owners every now and then argue that a construction contractor or the contractor's principles was negligent in the execution of the construction work. This argument may be a result of the owner's failure to protect or preserve his/her rights under the contract. Tort law in the United States is generally defined by state rather than federal law. Negligence cases often get to federal court through diversity jurisdiction, even though the case will typically be tried with some state's negligence law as the basis for decision. It should also be noted that the state law of negligence is usually common law rather than statutory law, with the effect that what is determined to be a lack of due care will differ from one jurisdiction to another. Moreover, in a negligence suit, the plaintiff has the

burden of proving that the defendant failed to act as a reasonable person would have acted under the circumstances. The court will be expected to instruct the jury as to the standard of conduct required of the defendant.

Gross negligence is when a person or party shows unrestrained disregard of consequences; where ordinary care is not taken in circumstances where, as a result, injury or grave damage is likely. A determination of gross negligence is a legal conclusion that can only be arrived at by a court of law. The distinction between ordinary negligence and gross negligence amounts to a rule of policy that a failure to exercise due care in such situations as where the risk of harm is great and will give rise to legal consequences harsher than those arising from negligence in less hazardous situations. Negligence is also said to occur when something is omitted that ought to be done.

With respect to design professionals, evidence of negligence is often noticed in the preparation of contract documents, for example, where there is a lack of coordination between construction drawings and site conditions or in evident discrepancies between building plans or specifications and shop drawings. When a design professional can be shown to be negligent, his/her license to practice may be temporarily or permanently revoked. However, while design professionals are required to possess and apply the same degree of skill, knowledge, and ability of other members of their profession and are required to exercise a standard of care and expected to apply their best judgment in executing the assignment, they cannot assume or guarantee that a perfect set of plans or contract documents will be provided or guarantee that the outcome will always totally achieve the owner's or consultant's objectives. It is important therefore that design professionals not undertake projects that clearly exceed their technical abilities or exceed those of the personnel available to work on the project. Only experienced, competent, and qualified staff should be assigned to a task. Junior and inexperienced personnel must be carefully supervised by fully qualified professionals. Outside consultants may be required to supplement the firm's own capabilities to achieve optimum results.

Standard of Care and Duty to Perform

The doctrine of reasonable standard of care basically implies that one who undertakes to render services in the practice of a profession is required to exercise the skill and knowledge that members of that profession (whether architect, engineer, contractor, etc.) normally possess. Here, design professionals often cite a California Supreme Court case with respect to the standard of care expected of professionals. The court in that case essentially

noted that services of experts are sought because of their special skill. They have a duty to exercise the ordinary skill and competence of members of their profession, and a failure to discharge that duty will subject them to liability for negligence. But it added that those who hire such professionals should not expect infallibility but can expect only reasonable care and competence. For example, with respect to the design professional, key points to remember relating to Standard of Care include the following:

- Possess learning and skill that is ordinarily possessed by the profession (at each stages of their work, e.g., in the preparation of drawings and specifications, overseeing the bidding process, approving shop drawings, equipment cut sheets, contractor payment requests, and the making of observations of the work to guard the owner against defects in the construction) practicing in the same or similar locality and under similar circumstances.
- The exercise of care and skill ordinarily possessed by reputable members of the profession practicing in the same or similar locality and under similar circumstances.
- The use of reasonable diligence and best judgment in the execution of the project.
- To achieve the objective, which is to accomplish the purpose for which the design professional was employed.
- Whether the design professional has violated the standard of care is usually determined by a jury in which the conflicting testimony of experts is heard and acted upon.

With respect to contractors, California courts have consistently held that the standard of care applicable to negligence claims against a contractor is that standard of a licensed contractor under similar circumstances. Moreover, expert testimony is required as to the standard of care itself, as well as to a defendant's compliance with it. Therefore, any reference to what a contractor defendant "should" have done using the standard of a reasonable person would not only be irrelevant, but it would also be prejudicial and improper.

According to Raymond T. Mellon, senior partner with the law firm Zetlin & De Chiara LLP, "It is imperative to note that the standard of care is kinetic and continually evolving. Both events and technology can and do affect and change the standard of care. Recent technological changes in the last 20 years have mandated revisions to building construction and safety. For example, many building codes now require various types of computerized fire safety devices, smoke detectors, strobe lights and other safety features not available 20 years ago. While complying with statutory

requirements for safety in building design is straightforward, the important issue raised by 9/11 is what design changes and technological advances must be incorporated into a building in the absence of statutory mandates. The fact that a building code in a particular municipality has not yet been amended to include new safety features or technological advances, does not, by itself, provide a safe haven from liability for damages incurred by a terrorist attack.”

Expert Witness

Employing expert witnesses in arbitration hearings, particularly related to construction litigation, continues to gather pace. This is important because the investigation and testimony of an expert consultant/witness can have an enormous impact on reputations and people’s livelihoods even though the service is essentially required to determine the cause, assign responsibility, and prevent the repeat occurrence of a failure. For this, and other reasons, it is really imperative that forensic experts understand the accepted standards that professional consultants and contractors are expected to meet. For example, is the Standard of Care bar raised when the designer/consultant or contractor is a LEED AP? The fact that a consultant makes a mistake, and that mistake causes injury or damage, is normally insufficient to lead to professional liability on the part of the consultant. For there to be professional liability, it must be proven that the services offered were professionally negligent, meaning that they fell below the expected standard of care of the profession. While it may be obvious that design professionals today have a duty to practise sustainable design, that professional standard of care may or may not rise to the level of promising the achievement of, e.g., a certain LEED certification level. R. T. Ratay, a forensic engineer expert defines the standard of care simply as being, “That level and quality of service ordinarily provided by other normally competent practitioners of good standing in that field, when providing similar services with reasonable diligence and best judgment in the same locality at the same time and under similar circumstances.” To do this, qualified experts are brought in and required to testify in American courts to the standard of care that was applicable to the case on trial; these qualified experts are also required to testify to the professional’s performance as measured by that applicable standard of care. Building contractors are exempted from applying the principle of standard of care because they are not deemed to be “professionals” in the sense of making independent evaluations and judgments based on learning and skill. However, they are nevertheless held to a “Duty to Perform,” which basically

means that they must strictly adhere to the plans, specifications, contract documents, and provisions of their contracts. Also, although the expert is generally hired by one of the parties, it is nevertheless important that he or she always remains objective and neutral.

Of note, on December 1, 2010, Rule 26 of the Federal Rules of Civil Procedure was amended to limit discovery that may be obtained from a party's testifying expert. The newly amended rule provides added protection because it now limits disclosures to actual "material of a factual nature." It should be noted that the trial systems in each country may differ. For example, the US trial system differs significantly from the German civil trial systems—not only in many of its details but also regarding their fundamentals. In the US judges most often have only a passive role, whereas in German civil litigation, the judge generally takes a very active role. He/she generally controls the proceedings, examines the witnesses, and in the end, is typically the decision-maker. There are also other differences such as the lack of pretrial discovery in Germany in addition to having a decisive role of court experts in German civil litigation.



16.4 ALTERNATIVE DISPUTE RESOLUTION VERSUS TRADITIONAL LITIGATION

The Nationwide Academy for Dispute Resolution (UK) Ltd., says, "A crucial distinction between litigation and ADR is that whilst many legal practitioners engage in ADR processes, there is no legal or professional requirement for either the ADR practitioner or for party representatives at ADR processes to be legally qualified or to be members of legal professions such as the bar or the law society. Many of those who engage in ADR practice are first and foremost experts in particular fields such as architects, builders, civil engineers, mariners, scientists and social workers, albeit with a thorough understanding of ADR processes and some knowledge and understanding of law. In house legal experts in large corporate organizations can take part in the entire ADR process without engaging professional lawyers thus cutting costs further, both in terms of time lost through communicating with the professionals and in respect of legal fees and costs."

16.4.1 Alternative Dispute Resolution Techniques

Whenever there is a downturn in the economy, we notice a strong impetus in encouraging professionals and businesses, both small and large, to try and find new and innovative ways to minimize expenses. It follows that with the rising costs associated with traditional litigation and other issues, many

businesses are now trying to avoid traditional litigation—either by turning to ADR methods or negotiating a prelitigation settlement to resolve construction disputes. It is also evident that in recent years, we have witnessed a significant surge in ADR popularity, especially with state and federal courts. The sudden popularity in ADR techniques is also partly due to the dissatisfaction by many in the industry with the current state of traditional civil litigation. This has invariably provided further impetus to the development of various ADR techniques, even though ADR techniques have been around for many years. In fact, the American Arbitration Association, which is a public service, not-for-profit organization, has been the leading advocate of ADR since 1926. ADR typically refers to a variety of processes and techniques for resolving disputes without litigation (i.e., that fall outside of the judicial process). Most people and corporations try and avoid being involved in lawsuits because formal litigation can entail lengthy delays, high costs, unwanted publicity, and ill will. After a decision has been rendered, appeals may be filed, which will extend the time required to reach a final result still further. Most ADR techniques, on the other hand, are typically faster, conclusive, and less expensive.

Research shows that ADR techniques such as arbitration, mediation, negotiation, and other out-of-court settlement procedures are now widely employed in the vast majority of construction disputes. They are especially useful where minor defects or failures are involved (Fig. 16.4a and b). ADR techniques are essentially based on the premise that disputes can best be

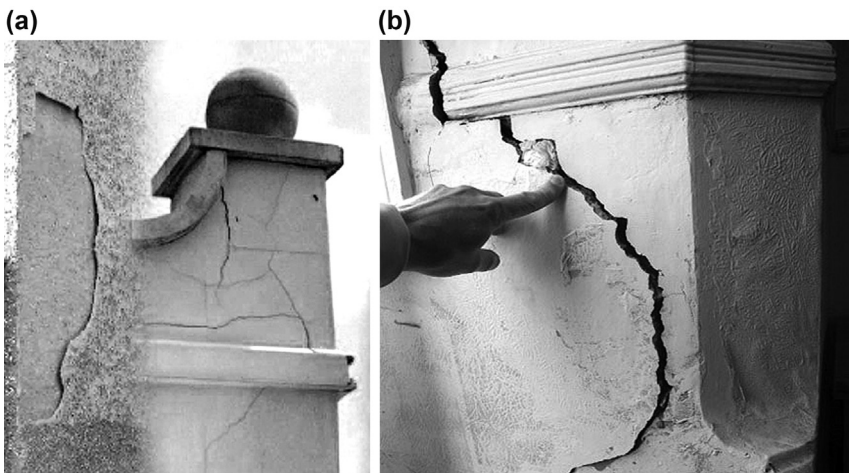

Figure 16.4 (a,b) Two examples of common failures that are not excessive in their magnitude and that can perhaps more readily be resolved through ADR (alternative dispute resolution) procedures.

resolved through negotiation or mediation immediately after a conflict comes to light rather than through the tedious, costly, and time-consuming route of traditional civil litigation. In such cases the only elements governing a quick resolution of the cases in hand is the eagerness of the parties to end the dispute and the complexity of the cases to be resolved. There are occasions when one of the parties to a dispute will insist on litigation; in these circumstances, it is usually because there are legal precedents that have been shown to be favorable to that party.

Generally, settlement discussions are often the best, least bruising, most private, and least expensive ways of resolving construction disputes. For example, most forms of ADR are not open to public scrutiny unlike disputes settled in court. Moreover, the hearings and awards can remain private and confidential; this helps to preserve positive working relationships. There are different methods of resolving construction disputes in the United States as [Table 16.1](#) clearly shows.

ADR techniques such as arbitration and mediation have proven to be viable, cost-effective alternatives to litigation. The American Arbitration Association (AAA) states, “Arbitration is the submission of a dispute to one or more impartial persons for a final and binding decision, known as an ‘award.’ Awards are made in writing and are generally final and binding on the parties in the case. Mediation, on the other hand, is a process in which an impartial third party facilitates communication and negotiation and promotes voluntary decision making by the parties to the dispute. This process can be effective for resolving disputes prior to arbitration or litigation.” Many jurisdictions in the United States have now made it mandatory to use ADR methods prior to accepting a case, and then only if ADR methods have failed to resolve the dispute in question. It should be noted that most attorneys advise clients to be cautious in choosing ADR methods over traditional litigation (especially when it is in their interests), and when ADR is decided upon, clients are encouraged to choose voluntary and nonbinding methods when possible.

Arbitration

Arbitration is becoming the favored practice for resolving construction disputes because for many, arbitration is considered to be a low cost and time-efficient alternative to costly court litigation. It is also one of the oldest and more common forms of ADR of which there are two basic types—binding (which means the parties must follow the arbitrator’s decision and courts will enforce it) and nonbinding arbitration (which means that either party is

Table 16.1 Table highlighting the primary advantages and disadvantages of different forms of resolution

Resolution process	Advantages	Disadvantages
Negotiation/ assisted Negotiation Mediation	<ul style="list-style-type: none"> • Parties have control • Confidential • Structured • Skilled mediator helps avoid entrenched positions • Control and resolution lies with parties • Helps maintain future commercial relationship for parties • Costs less than litigation • Quick result • Confidential 	<ul style="list-style-type: none"> • No structure • Entrenched bargaining positions likely • No decision if parties do not agree • A resolution may not be reached
Arbitration	<ul style="list-style-type: none"> • Structured • Can be quick, timetable controlled by parties • Costs may be less than litigation • Confidential • Structured 	<ul style="list-style-type: none"> • Parties do not have control • Imposed decision • May jeopardize future relationship of parties
Litigation (court action)	<ul style="list-style-type: none"> • Structured 	<ul style="list-style-type: none"> • Timetable controlled by court • Costs may be significant • Parties do not have control • Imposed decision • May jeopardize future relationship of parties • Long waiting times • Goes on public record (no confidentiality)

free to reject the arbitrator’s decision and take the dispute to court, as if the arbitration had never taken place). And although arbitration includes participation of the parties on a typically voluntary basis, it can only be legally enforceable and binding if agreed by the parties beforehand. To become binding by the arbitrator’s decision, a separate written agreement needs to be in place certifying that the arbitration agreement has been read and understood and agrees to be bound by it. An example of a simple arbitration

clause is, "All claims and disputes arising from or in connection with this Contract are to be settled by binding arbitration in the state of (insert state in which parties agree to arbitrate) or another location mutually agreed upon by the parties. The arbitral award is final and binding upon both parties and may be confirmed in a court of competent jurisdiction." Traditionally, the AAA has been the forum for resolution of such cases, and it has developed detailed rules governing the arbitration process. Copies of the American Arbitration Association Dispute Resolution Procedures governing arbitration and mediation, as amended through January 1, 2003, may be obtained from the American Arbitration Association, located at 133 Federal Street, Boston, MA 02110, as well as from the AAA's website (www.adr.org).

When using arbitration, a third party is agreed upon who acts as a private judge and who is authorized to render a final decision. The feuding parties control the range of issues to be resolved by arbitration, the scope of the relief to be awarded, and many of the procedural aspects of the process. The contract between the owner and builder or designer may very well include an arbitration clause, although even if there is not one, a disputant party can still choose to take the case to arbitration. This may be why most residential construction contracts now contain arbitration clauses; likewise, the use of arbitration provisions in commercial construction contracts is becoming increasingly common. Nevertheless, it is extremely prudent to obtain legal advice before making a determination to proceed with arbitration proceedings or not. The main attraction of arbitration is that it costs less than a trial and has the added advantage of often having a speedy outcome, as well as relative privacy of the parties. Also, because the parties control the process, they can enjoy tremendous flexibility.

Upon making a determination to go to arbitration, all the facts need to be sorted out and the pertinent issues in dispute established. A decision must also be made who the potential witnesses for each side are to be, as well as determining who the arbitrator is to be as well as the venue for the arbitration hearing. In most initial settlement discussions, expert consultants do not usually attend, although the parties may rely on their respective expertise in formulating their respective positions. Expert consultants however do usually participate in mediations and are often the primary presenters of their clients' technical positions and are relied upon to provide continuous input throughout the ongoing arguments. It is highly unlikely that the arbitration process can proceed without the use of expert witnesses, partly because arbitrators will often probe deeply into technical matters of the case, and also to achieve for the parties credible and authoritative presentations of their technical positions in the case.

However, with regard to litigation, an expert testimony at a trial of cases involving architecture, engineering, and construction is usually required by the court for the purpose of elucidating to the judge or jury the technical aspects of the case; and each of the feuding parties wants the judge or jury to hear their own technical positions as expressed by their own experts as well as to hear challenges to opposing experts' opinions and conclusions.

Mediation

This is another ADR nonbinding process by which an impartial person, the mediator, facilitates the negotiation process between the parties to a dispute to promote reconciliation, settlement, or understanding among them. The main objective of mediation therefore is to assist the parties in voluntarily reaching an acceptable resolution of issues in dispute with the aid of the mediator who is a neutral third party. The mediator's role is solely advisory, in that the mediator may offer suggestions on ways of resolving the dispute, but in no way should he or she try and impose a resolution on the parties. Mediation proceedings are confidential and private. Also there are no hard and fast rules of procedure for the mediation process, and this allows the mediator and the parties to seek out the most effective and efficient method to resolve the conflict. Mediation has several important advantages and fewer disadvantages than the other options which is why it is gaining popularity as the ADR method of choice for resolving disputes. Among the advantages of mediation are lower costs; efficiency; and the ability to preserve business relationships, potential speed, and flexibility in resolving the dispute.

A nominated mediator must have the approval of all the parties involved in the dispute. The approval process includes the disclosure by the potential mediator of any past, present, or future relationships with the participants in the mediation. Mediators often have special training that allows them to assist the parties in identifying the real issues that separates them, while fully comprehending what is in their best interest and helping the parties to reach an agreement on some or all of the disputed issues to provide certainty and clarity. For this reason, the mediator should preferably have expertise in construction and construction claims in addition to being well versed in construction law. A mediator, like a facilitator, makes primarily procedural suggestions regarding how parties can reach agreement because the final objective is all about reaching a compromise. Clients often find themselves having to forgo some of what they consider as their legal rights in the matter. Some mediators try to set the stage for bargaining, by making minimal

procedural suggestions, and intervening in the negotiations only to avoid or overcome a deadlock. Other mediators may get much more personally involved in forging the details of a resolution. Mediation has been found to be particularly useful in highly polarized disputes where the parties have either been unable to initiate a productive dialogue or where the parties have been talking but appear to have reached a seemingly insurmountable impasse. If it is determined that the parties are unable to reach an amicable agreement, the case will then have to go to court. This will incur significant costs such as legal expenses, as well as considerable time and energy. But even if mediation fails, the parties may still make an effort to settle just to avoid the exorbitant court process, without either party admitting fault. In some countries such as the United Kingdom, ADR is synonymous with what in other countries is generally referred to as mediation.

Unassisted and Assisted Negotiation

Negotiation is a time-proven approach to resolving disputes between feuding parties through discussions and mutual agreements. In an unassisted negotiation, the parties attempt to reach a settlement without involvement of outside parties. This process is essentially voluntary and there is no third party to facilitate the resolution process or imposes a resolution. This informal process is one of the most fundamental methods of dispute resolution, offering parties maximum control over the process. But as with any endeavor, negotiation can be effective or unproductive. To be successful, the parties should be from the outset to identify issues upon which they differ and identify possible settlement options. The parties should also disclose their respective needs and interests to enable them to negotiate acceptable terms and conditions of agreement. The most appropriate and successful approaches in negotiations are those in which the negotiators conduct discussions that focus on the common interests of the parties and not the traditional approach of focusing on the parties' relative power or positions. A construction industry negotiation variant is the "step negotiation" procedure, which is a multitiered process that is sometimes used when the information that the parties have in place is, e.g., incomplete, or as a mechanism to break a deadlock. But while no specific mechanism or formula specifically requires the institution of settlement negotiations, many contracts today contain a "good faith" negotiation clause, requiring any dissatisfaction with performance under a contract to be communicated to the other party, usually in writing. The final objective of negotiations is that each party ends up in a better position than if they had not negotiated.

In an assisted negotiation, a third party (outsider) to a dispute is agreed to who brings the parties together and, to varying degrees, helps them to resolve their disagreements. Here, the decisions remain in the hands of the parties themselves, and the function of the third party is mainly to assist the parties in negotiating a mutually acceptable agreement. In some cases, the third party may suggest a particular settlement. This model is increasingly being used internationally in construction contracts.

16.4.2 Traditional Litigation

Litigation is the traditional form of dispute resolution and is based on taking action through the courts. In traditional litigation, a judge typically sits and listens to arguments and expert witnesses on the interpretation of the relevant law as applied to the particular dispute and then makes a determination as to who wins and who loses. The traditional litigation process can be complex and drag on for years; it can also be extremely costly. Traditional litigation necessitates the observance of certain protocols regarding rules of evidence and procedures for such things as reports, pre-trial discovery techniques, interrogatories, depositions, and direct/redirect and cross/recross examination. It is helpful if the consultant, building owner, or product manufacturer have a basic understanding of the different stages and procedural details of civil lawsuits. Litigation procedures are generally governed by statute in each jurisdiction. Federal and civil trials are normally governed by the *Federal Rules of Civil Procedure* (FRCP). Although each state has its own rules of civil procedure, in many states these are similar to the FRCP. Moreover, many courts have their own local rules of procedures that supplement federal or state rules. Traditional litigation lawsuits are normally divided into two basic stages: (1) Pretrial and (2) Trial.

Under US law, discovery is the pretrial phase in a lawsuit in which the parties are identified and the issues in dispute are clarified. In addition, each party is given an opportunity to learn about the other party's witnesses and potential evidence. Each party can request documents and other evidence from the other parties or can use a subpoena or through other discovery devices to compel the production of evidence and depositions. Many states are adopting discovery procedures that are more or less based on the federal system; in some cases the federal model is closely adhered to, while in others it is not. Also, some states take a totally different approach to discovery.

When a lawsuit is filed against an individual or firm, the next thing the plaintiff must do is "serve" the individual or company with the "summons" and "complaint." In most jurisdictions, traditional litigation starts with the

service of a summons. The complaint consists of the plaintiff's factual and legal allegations against the individual or firm. The summons is basically a document that notifies the individual that he or she is required to appear in the lawsuit and file a response to the complaint. This would usually take place sometime after a failure or deficiency has actually occurred. In federal court, the suit starts when the summons and complaint are filed with the court prior to service on the defendant. This gives the attorneys for the defendants an opportunity to reply to the complaint and may also decide to possibly file a counterclaim. If a counterclaim is filed, the plaintiff's attorney is expected to answer the counterclaim. Either way, the defendant must respond to the plaintiff's complaint by denying or admitting the allegations. Should the defendant fail to respond to the plaintiff's allegations, it may be considered an admission of guilt by the defendant.

Sometimes the defendant may decide to utilize third-party practice to bring an outside party into the suit and who may be liable to the defendant if the defendant is liable to the plaintiff. Thus, a defendant owner may serve a third-party complaint on a contractor or consultant designer claiming that should the owner be found liable to the plaintiff, then the contractor or consultant designer would be liable to the owner to the extent that the liability was caused by defective construction or design.

Discovery, inspection, and disclosure techniques are frequently used by attorneys to reveal details of the adverse party's claim; it also allows a party to inspect an adversary's files. This can be initiated by the attorney of the defendant, plaintiff, or third party, serving a document demand on the adversary to view certain documents that the party wishes to inspect such as minutes of job meetings, photographs, tests, and correspondence.

Interrogatories, which are part of discovery, consist of written questions formulated by one party and served upon the other and which are required to be answered in writing, and may only be served on a party to the lawsuit. Interrogatories are intended to cover issues that help prove or disprove the presence of material fact. Where the issues are technically complex, experts may be brought in to assist and clarify the issues. The party receiving the interrogatories is required to answer in writing and under oath within a specified time period (30 days under FRCP 33).

Deposition testimonies are oral questions, given under oath and which may be taken of witnesses as well as parties. They normally take place prior to trial commencement and consist of in-depth questions of a party or witness by the attorneys of the various parties involved in the case. They consist mainly of a cross-examination given under oath and

recorded verbatim, but in the absence of judge and jury. Depositions often assume cardinal importance at a trial and can be used for any relevant purpose including the discrediting of trial testimony, impeach, or throw doubt on a witness's credibility.

Pretrial conferences are often employed by judges and attorneys to encourage settling cases. Thus, prior to trial commencement the attorneys for both sides will often meet with the trial judge in a pretrial conference to review the evidence and clarify the issues in dispute and to determine whether a settlement is possible or not. If settlement is not possible, a date for commencement of the trial is set and the attorneys and judge then decide how the trial will be conducted and what types of evidence are to be admissible. This is followed by jury selection (called *voir dire*), which depends largely on the jurisdiction of the trial. It can either be accomplished by the attorneys themselves or by the judge, depending on the rules constrains of the court where the case is being heard. Once jury selection is completed, the trial can begin with opening statements by the attorneys of the plaintiff and defendant. These statements typically outline the strategy that will be used by the respective attorneys of each party to prove their case. Upon the lawyers completing their opening statements, the plaintiff's and defendant's witnesses take the stand. The witnesses are examined and cross-examined by the adversary's attorney. Closing arguments are then made by the defendant's attorney and the plaintiff's attorney. The judge will then advise the jury on the laws that are applicable to the facts of the case, and then the jury is allowed to deliberate to make a judgment. This gives the jury an opportunity to inspect all the relevant testimony and documents entered into evidence prior to a final verdict being reached. Once the jury has reached a decision, it issues its verdict in favor of one of the parties.

16.4.3 Professional Ethics and Confidentiality

Professional ethics can generally be defined as an established set of principles that govern how a professional relates with clients, fellow professionals, and the public at large. Most professional specialty fields today have their own rules of professional conduct, which is monitored by the memberships' leaders. Thus, the vast majority of contractors, and professional architects, or engineers continue to be governed by ethical obligations of their own professional organizations and associations, most of which have their own code of ethics. Typical examples are those of the American Institute of Architects (AIA) and the American Society of Civil Engineers (ASCE) each of which

has their own code of ethics. However, it is important to fully understand the interplay between professional ethics and legal liability, in governing the activities of engineering and construction professionals. According to the American Society of Civil Engineers (Guest Editors: Tara L. Hoke, JD, Steven K. Starrett, Ph.D. P.E., FASCE), subjects that should be considered include but are not necessarily limited to the following:

- Ethical and legal compliance for engineering projects in the global marketplace
- Contract liability limitations and personal liability for design professionals
- Defining the standard of care
- Employment ethics: enforcement and applicability of confidentiality, noncompete and nonsolicitation agreements
- Procurement ethics and legal obligations
- Ethical rules and legal obligations for engineering and construction professionals in the public sector
- Ethical issues in expert witness selection, compensation, and testimony
- Conflicts of interest in multiparty construction dispute resolution
- Creating the ethical workplace: policies and procedures that promote ethical vigilance and legal compliance
- Whistle-blowing.

Lawyers are fiduciaries of their clients. One of these fiduciary obligations requires lawyers to protect the confidentiality of their clients' information. It is important that experts and professionals in civil litigation, who are or were retained by an attorney on a client's behalf, should always observe client confidence and confidentiality. Upon being aware of this duty, there is an obligation to treat all information obtained from the client directly or through the attorney in complete confidence. This obligation arises from the fact that the attorney hired the expert/professional to act for the client and as the attorney is sworn by his/her code of conduct to maintain and preserve the client's confidence, so must the expert/professional. It should be noted that litigants do not normally file discovery documents in court in civil litigation, unless a matter is intended to go to trial. Such documents and recordings should not be released to third parties without the attorney's permission, although a release may waive the privilege.

In the legal profession, there is a fiduciary responsibility and duty of loyalty that is owed to a client and which prohibits an attorney (or law firm) from representing any other party with interests that conflict with those of a current client (the few exceptions is when all affected parties give written consent). And although the law pertaining to conflict of interest is very complicated,

a potential conflict does obviously exist when an attorney attempts to oppose a party he/she previously represented. A potential conflict of interest exists whenever a prior representation may in any way influence the attorney's loyalty to a current client. In fact, attorneys, experts, and professionals may be privy to customer lists and other proprietary business information, hold government secret classification status and be committed to keep the information confidential. All such prior confidential commitments could come into conflict when an expert or professional agrees to act as a consultant and possibly testify. Even the appearance of impropriety should be avoided at all costs by the attorneys, experts, and professionals.

Whenever a potential conflict does exist, it is the duty of the professional to disclose the nature of the conflict to the attorney and to allow the attorney to determine whether the professional should continue to function on the client's behalf. As a technical specialist, a consulting expert has a professional obligation to uncover all the relevant facts relating to the issue being investigated whether it is in the client's best interest or otherwise. And if a construction failure should occur, each of the involved parties (i.e., owner, contractor, design consultant, etc.) will typically necessitate retaining an expert consultant to investigate the causes of and responsibilities for the failure. If later deemed necessary, the expert may be required to provide technical support in the litigation of potential claims. Experts and consultants can play critically important roles in litigation and the evidence of an expert witness can have a dramatic impact on a case and in many cases determine its success or failure (bearing in mind that the service and role played by a particular expert will vary from case to case).

The special knowledge that experts have by virtue of their skill, experience, training, and/or education, goes beyond the normal experience of the general public, to an extent that others may officially (and legally) rely on their opinion on such matters. This acknowledged expertise in their chosen subject often gives their testimony considerable moral authority in the eyes of the court, and their written reports may also facilitate a settlement where their view of the evidence is both concise and clear and able to find for one side over the other. Furthermore, the expert witness is formally allowed to offer an opinion as testimony in court without having been a witness to any occurrence relating to the lawsuit. It is important too that the expert witness is articulate and able to present highly technical matters relating to architecture and engineering in language that can be easily comprehended by the nonexpert. In the resolution of construction-related claims, the expert becomes a valuable and necessary professional.



16.5 INSURANCE PROGRAMS AND REQUIREMENTS

The extremely complex field of liability makes it almost impossible to adequately address the endless concerns and legal matters that may arise with regard to liability issues in this section, which is why builders, manufacturers, and designers are strongly advised to consult their attorneys and professional liability insurance carriers for advice on such matters. Although building owners and managers are not expected to guarantee the safety or well-being of their tenants, visitors, and guests, they are required to exercise reasonable care to protect them from foreseeable events. The number of liability lawsuits filed against American companies has increased so dramatically over the last decade that it has become a major concern to all involved in the construction industry.

Attitudes to insurance vary and few fully understand it. To put it simply, an insurance policy consists of a legal contract expressed in relatively complex legal terms. What it does is promise to provide compensation for something (e.g., a potential loss), which may never happen, although in the construction industry can and often does happen. Indeed, contractors lacking adequate insurance risk the success of their business and even potential bankruptcy. Independent and expert advice is imperative. Insurance should be considered as crucial to the continued operation of the business, as few companies and proprietors in the building trade have sufficient capital to meet adversity from their own resources. While there are many inherent risks in building construction projects (including green projects), and which may be inevitable in most businesses today, properly arranged and appropriate insurance can remove or mitigate many of the risks for a small cost compared to the potential devastating liabilities that can ensue by not having it. With most things that are new, there are challenges to be faced, and certainly going green is no exception. From an insurance perspective, Zurich Insurance says that “what matters the most is the claims process. It’s important to ask, are there people in place who know how to order and rebuild to green standards?” Zurich goes on to say, “What we see now is a growing number of insurance carriers providing different coverage forms for green buildings, and the question is how much real coverage they are providing. There are obviously some unique exposures associated with these types of facilities, and the key issue will be how the market addresses those exposures with coverage.”

There are several types of insurance policies commonly used in the construction industry that the contractor and their subcontractors should

have to protect the owner/developer from financial loss, whether in the form of property damage or bodily injury or both. The most common types of insurance policies available to the construction industry include the following:

- Commercial General Liability policies (CGL)
- Builder's Risk policies
- Errors and Omissions policies (E&O)
- Workman's Compensation Insurance
- Professional Liability Insurance.

16.5.1 Commercial General Liability

CGL insurance is designed to protect business owners against claims of liability for bodily injury, property damage, and personal and advertising injury (slander and false advertising). For construction companies, liability insurance is one of the most important types of insurance that a construction company can carry. This insurance type is intended to protect the policyholder and other named insured for claims instituted by third parties. It also protects the contractor and the company from damages or injuries sustained by others on-site due to faulty workmanship, damage to your property and injuries to persons as a result of the contractors operations or their negligence. In most cases, the construction contract will specify that the subcontractors name the general contractor as an additional insured on their respective CGL policies. Both general contractors and subcontractors typically hold CGL policies that cover personal injury and property damage on either an occurrence or claims-made basis. Also, CGL policies contain a general aggregate limit that states the maximum limit that the insurer will pay out during the policy period for damages resulting from bodily injury, property damage, and personal and advertising injury. If for some reason the contractor does not have adequate insurance the owner/developer could be the one financial responsible.

Obtaining General Liability insurance has not been easy for many contractors in recent years due mainly to the construction defect litigation crisis. To address this crisis, some in the insurance industry have started restricting coverage in their General Liability policies by placing numerous exclusions in the "fine print" resulting in lack of coverage for many types of lawsuits. These exclusions typically include but are not limited to EIFS, Mold, Lead, Products-Completed Operations, Prior Completed Work, Damage To Work Performed By Subcontractors On Your Behalf, Subsidence, Contractual Liability Limitation, Independent Contractor

Exclusion, Roofing Operations Exclusions, etc. It is imperative for stakeholders to fully understand the coverage implications of these exclusions if they are contained in the General Liability policy and decide on what action to be taken if any.

An attorney and partner with Howrey LLP, Seth Lamden says, “After nearly three decades of litigation and scores of decisions from nearly every jurisdiction, courts still do not agree on whether a commercial general liability (CGL) policy protects a general contractor against claims for property damage occurring after the construction project is complete when the damage is caused by the defective work of a subcontractor.” Lamden goes on to say, “The battle still rages on as to whether a general contractor should be entitled to coverage for liability resulting from damage to the completed project caused by the defective work of a subcontractor. A close reading of the standard form CGL policy reveals that the policy should provide such coverage. Until courts agree on this issue, however, general contractors should be aware of the insurance law in their jurisdiction regarding how CGL policies are interpreted in the construction context to make sure that they truly are protected from the main risk they face on construction projects.”

16.5.2 Builder’s Risk

Builder’s Risk insurance is generally intended to cover a project owner or general contractor for damages resulting from an insurable incident during the construction of the project. Normally the policy is an all-risks policy, meaning that all incremental costs are typically recoverable from the insurance company unless they are specifically excluded within the policy. A builder’s risk policy normally includes and covers the physical damage to the project, extra expenses, expediting expenses, soft costs and in many cases delay in start-up losses due to flood, collapse, and so forth. The policy may also cover (subject to exclusions and limitations), third party acts and negligence. Builder’s risk insurance is critical to limit the policyholder’s exposure if he or she is looking to build a new building or renovate an existing one. In this respect, builder’s risk policies differ from CGL policies in that they focus on losses incurred by the policyholder as a result of damage to the project during construction rather than focus on losses incurred by third parties. Builder’s risk insurance is generally purchased on a project-specific basis and usually indemnifies against damage and losses due to fire, theft, wind, hail, lightning, explosion, and similar forces. Faulty workmanship and construction defects are generally excluded from coverage, as are earthquakes, flood, acts of war, or intentional acts of the owner. These insurance

policies are designed to insure construction projects, and cover buildings and other structures while being built, including building materials and equipment designed to become part of the building or structure, whether the materials are being temporarily stored, on a delivery truck, on merely on the project lot waiting to be installed. It will usually last from the start of construction to acceptance of the completed project. This policy is typically purchased by the project owner although the general contractor constructing the building may purchase it if it is stipulated as a condition of the contract.

In most builders risk policies, we find less exclusion and many of these policies cover flood, earthquake, testing, and in addition provide broader transit and off-premises coverage. Nevertheless, there is a potential problem that may arise with a separate builders risk policy, which is securing permanent coverage when the builders risk policy expires. Builders risk policies typically contain a provision stating when the coverage will expire, but this provision will vary according to policy. Such provisions may create potential problems should the permanent commercial property insurance not be placed in a timely manner. Furthermore, the owner always has the option to delegate the responsibility for obtaining the required builders risk insurance to his GC. This is not an uncommon practice with larger contractors because the latter are generally more familiar with the market and the type and amount of coverage needed, which is why they prefer to have a degree of control over who will ultimately be insuring the project. It is important to maintain sufficient builders risk insurance and insurance consultants need to be familiar with the construction contract, particularly clauses pertaining to responsibility for procuring adequate and appropriate insurance. It is incumbent on all stakeholders to know not only what coverage is required by the construction contract but also what coverage is available in the marketplace, so that the proposed insurance policy provides appropriate protection to face the many potential challenges and exposures that may arise.

16.5.3 Errors and Omissions (E&O) Insurance

Errors and Omissions policies and coverage are basically malpractice insurance and protect a professional from malpractice claims in the execution of their work and relating to an error or omission in providing professional services that can lead to a lawsuit. Errors or omissions can occur on almost any transaction, although many owners tend to expect and believe that the Architect will produce a perfect set of design and contract documents. Design professionals know this is not possible, yet hesitate to discuss the

potential of errors and omissions with the client. It is in the interest of the design professional that this discussion takes place.

E&O coverage extends to the payment of defense costs, court costs, and any resulting judgments up to the policy limit. E&O insurance, may exclude negligent acts other than errors and omissions (“mistakes”), is most often used by consultants, brokers, and various sorts of agents. Because liability for a design professional’s negligence claims are not addressed in CGL policies, the E&O policy becomes the primary protection tool for these professionals. The category covered by this policy includes architects, engineers, accountants, and attorneys, etc., for alleged professional errors and omissions, which may amount to negligence. Errors and Omissions Insurance protects a company from claims when a client holds the company responsible for errors, or the failure of executed work to perform as promised in the contract. The prudent Administrator or Consultant therefore tries to provide a “safety net” to ensure mistakes are caught and corrected before they cause major problems. Checklists and construction reviews are very helpful in this respect. Owners should also watch out for gaps in coverage, which are common in E&O coverage. A gap in coverage or lapse in coverage may be caused by not renewing the professionals E&O coverage the same day it is to expire. Some carriers will not allow professionals to backdate their coverage to their expiration date without a valid and acceptable explanation (e.g., a natural disaster or personal medical issue that prevented on time renewal) in addition to a signed warranty letter to the carrier stating that the specific professional unaware of any pending claims; for example, if the effective date of insurance is 01/01/2011 and the coverage expires on 01/01/2012, and the professional fails to renew the E&O coverage on or before 01/01/2012 then the professional may have to enroll with a gap in coverage, resulting in a loss of prior acts coverage. This means that the professional will have no coverage for any business placed “prior” to the new effective date. Some carriers, however, may allow a 30–45-day grace period, although it is not uncommon for them not to allow this. But perhaps the most important thing the Administrator can do to control professional liability in this area is to educate the client and reach a clear understanding that errors will occur, and that by working together such errors can be corrected in a timely manner.

16.5.4 Workman’s Compensation Insurance

Under current law in most states, every business must have some form of workers’ compensation insurance to cover injured employees. This type of coverage generally provides compensation and medical care for employees

who are injured in the course of employment, in exchange for mandatory relinquishment of the employees' right to sue their employers for the tort of negligence. In the United States, every state has its own workers' compensation laws; these are contained in statutes and will vary from state to state. Moreover, there are different workers' compensation laws for employees of the federal government, and others for workers in specific types of industries such as railroad employees. It should be noted that in the United States, workers compensation insurance is not required by every employer and furthermore, in some states small businesses that employ less than three to five employees likewise may not be required to carry workers compensation insurance. Nevertheless, in today's litigious environment, it is strongly recommended to have such coverage if possible. The alternative may be being set up for a massive legal bill, unlimited personal and or corporate financial liability, including punitive damages that could run in the millions. In this type of plan, general damages for pain and suffering, and punitive damages for employer negligence are generally not included.

16.5.5 Professional Liability Insurance

Unfortunately, professional liability insurance is often an afterthought for large-scale construction projects, especially within this environment of increasing litigation, in which the private practice of a design professional or contractor can be particularly vulnerable, not least because of the damage that even an unfounded lawsuit can do to reputation and financial stability. Business insurance is especially imperative because it offers protection to both the owner and the business with coverage for claims related to allegations of negligent activities or failure to use reasonable care. Also, the latest innovative technologies are encouraging the emergence of new project delivery systems including design-build and public-private partnerships (sometimes known as 3P projects), causing the lines between design and construction to often become blurred, which may be why professional liability risks have become increasingly difficult to insure adequately. To minimize these potential risks to litigation, there are several steps that can be taken. Here, we find five major areas of interaction between the Consultant/Administrator and other members of the project team. These areas are where the Consultant/Administrator can do the most to protect themselves from liability:

- Professionalism
- Interpersonal Relationships
- Business Procedures

- Technical Procedures
- Professional Liability Insurance.

Of note, some insurance policies go further than the standard coverage. In most cases, professional liability insurance coverage does not cover such things as defamation (libel and slander), breach of contract or warranty, security, personal injury, or intellectual property. Coverage can often be added to provide indemnity “for any civil liability.” The operative clause of a civil liability policy is very wide and normally consists of a long list of exclusions so that liabilities, such as employers’ liability and public liability, are not covered under this policy because they are the subject of other forms of insurance. Whatever the case, it is imperative that before signing a policy, it is well understood, preferably with the assistance of an attorney.

16.5.6 Standard Documents and Related Issues

Construction projects in the United States often involve the use of standard documents published by organizations such as the American Institute of Architects (AIA) or the Associated General Contractors (AGC), to name only two. Some project owners nevertheless prefer to prepare their own documents, using a combination of standard and other forms. In both the AIA and AGC documents, project owners are required to provide builders risk insurance covering the interests of all those involved in the project. This policy should generally provide the following:

- “All-risk” or comparable coverage
- Coverage for property at the job site, material stored off-site or in transit
- Coverage for all parties/stakeholders to the contract: owner, lenders, contractors, subcontractors, architect/engineers, etc.
- Permission for waivers of subrogation among the parties
- Coverage for the duration of the project

The construction contract itself, although not a party, remains a crucial element of the construction project. The contractors’ equipment insurance should provide coverage for construction equipment, such as forklifts, bulldozers, mobile tools, etc. The project owner can also add the construction project to its regular commercial property policy, ensuring there is compliance with the above criteria, or alternatively purchase separate builders risk coverage. The builders risk approach has the advantage of having significantly broader coverage than that provided by standard commercial property insurance. In some contract documents such as the AIA document, for example, should the owner decide not to purchase the builders risk insurance, he/she must inform the GC in writing prior to commencement of

the project. This gives the contractor the option of then obtaining the necessary insurance including protecting the interests of all parties and charging this coverage to the owner.

The Joint Contracts Tribunal's (JCT) in the United Kingdom has a Standard Form of Building Contract, which is considered to be a common standard contract used to procure building work, and which is updated regularly to take into account changes in legislation and industry practice and relevant court decisions from litigation (<http://www.jctld.co.uk>). For example, the JCT 2005 contract looks very different to the JCT 1998, even though the insurance provisions have not been significantly altered, and today most commercial building work in the UK is carried out under a standard form of contract, with or without amendments. The JCT then launched a new set of publications, the JCT 2011 Tracked Change Documents, which highlight the differences between JCT 2005 and the latest 2011 edition. Notably, the JCT recently published its latest 2016 Edition. Here, JCT Chair, Richard Saxon CBE, noted, "It could be said that JCT is one of the only fully industry-wide collaborative forums. As well as helping us to achieve our primary objective of producing our suite of contracts, our collaborative approach has a wider impact in terms of acting as a sounding board for the industry, and enables us to provide products and services for the industry that go beyond standard contract documents." He went on to say, "JCT was the first standard form construction contract authoring body to produce specific provisions in respect of collaboration, sustainability, the public sector and BIM. The 2016 Edition continues that evolutionary process."

There are a number of factors that need to be recognized and taken into consideration when taking out an insurance policy for a building project. These include the following:

- That there are several parties that have insurable interests in the overall construction project.
- Materials and equipment can normally be located on or off the job site, and at different times may belong to the owner, general contractor (GC), or subcontractors. Some materials and equipment may be owned by suppliers but these individuals or entities are not considered to be subcontractors. Because their interests are rarely covered by the course of construction policies, they have to be specifically added.
- To make it easier to purchase insurance and to avoid potential gaps in coverage, one of the parties to the contract will usually be required to assume responsibility for insuring the project on behalf of all parties.

- Responsibilities of the various stakeholders, including responsibility for obtaining insurance, are generally clearly articulated and delineated in the construction contract.

In building construction, losses may be the consequence of a number of factors including the following:

- Negligence; lack of skill and care, and failings in design, specification, workmanship, or materials;
- The building construction process—i.e., materials, workmanship, security, heat work, health and safety procedures, etc.;
- Environmental factors including weather, ground conditions, proximity to hazards;
- The inability to complete a contract on time, resulting in financial losses (whether due to insured perils or insolvency of contractor);
- Close on-site proximity of various contractors, subcontractors, and professionals, leading to a significant public liability risk in addition to employer's liability exposures, the result of carrying, lifting, working at height, confined spaces, collapse, dropping, toppling, etc.

If the GC sustains a loss due to the owner's failure to obtain or maintain coverage, without notifying the GC, the owner will then have to assume responsibility for all reasonable damages sustained by the GC. To meet the contractual obligations and requirements regarding insurance, the insurance consultant may be required to negotiate modifications in coverage to comply with the contract. In cases where it is not possible to obtain specific coverage, for say, flood or earthquake, then modifications to the construction contract may be necessary and such requirements deleted.

16.5.7 Influence of Green Features on Insurance Policies in the United States

Over the last two decades, green building and the green industry has been able to move deeply into the mainstream, forcing many insurance carriers to sit up and take notice. Still professional liability continues to reflect how the insurance industry as a whole has yet to fully comprehend the changing demands of green building and respond with appropriate insurance policies. A number of insurers such as Chubb, Zurich, and Lexington are realizing the new demands of green building and are finding that they are at the vanguard of the insurance industry. They possessed the vision to respond rapidly to the growing needs and demands of policyholders, while also understanding the risk reduction and economic value associated with green building construction. In this respect, Peter Thompson, Vice President, Chubb &

Son, says, “For years, Chubb has been a leader in insurance protection for green buildings through its commercial property insurance policies.” The Chubb Group of Insurance Companies also say that commercial property owners now have a cost-effective way to repair damaged property using “green” materials and environmentally friendly construction techniques. According to the Chubb Group, a new endorsement “Customarq package policy” is offering commercial property owners a “green upgrade” option “to help pay to repair damaged covered property using environmentally-friendly materials, low-impact construction processes and efficient heating and cooling technology after an insured loss. Chubb will pay the difference between repairing the property to its pre-loss condition and repairing it using green materials and construction techniques, subject to the applicable limit of insurance. The option is available for property that did meet, or no longer met, green certification standards in effect at the time of loss or damage.” “As businesses look to help protect the environment and improve their operations, Chubb continues to innovate around our customers’ desire to go green,” said Bill Puleo, worldwide mono-line property manager for Chubb Commercial Insurance. “Whether businesses wish to enhance their buildings with green features, achieve LEED certification or build green from the outset, the property insurance we provide can be tailored accordingly.”

Another example is Lexington Insurance Company, a Chartis company, which is a world leading property-casualty and general insurance organization serving more than 40 million clients in over 160 countries and jurisdictions which announced on August 2009, the introduction of Upgrade to Green—Builder’s Risk, which provides coverage that supports green building construction and renovation projects registered with the LEED or the GREEN GLOBES rating systems. The upgrade to Green is available as an endorsement to Lexington’s Completed Value Builder’s Risk Policy, and extends coverage to address the risks green buildings face during three key areas of construction: project management and administration, site ecological impacts, and consumption of resources.

Lexington Insurance says, “In the event of a covered loss to a green building, Upgrade to Green provides coverage for the fees of qualified professionals associated with the building’s design and restoration, as well as the costs of re-commissioning building systems and replacing vegetative roofs. Additionally, the product responds to changes to the relevant rating system criteria or loss of anticipated rating points as a result of a covered loss. For example, Upgrade to Green provides coverage if the new rating criteria require more points to achieve the anticipated certification level, or if the

criteria to achieve the same number of points are more stringent and costly. It also provides extra remuneration for reconstruction or rework to secure new rating points if, as a result of covered damage, anticipated rating points are lost and no longer available.”

This is emphasized by Liz Carmody, Senior Vice President, Lexington who says, “We are committed to supporting sustainable development through innovative green products and services,” and “Upgrade to Green, which is part of our Ecosurance portfolio of green products, addresses the unique risks that green construction and renovation presents to property owners.” In the event of a covered loss to a green building, Upgrade to Green provides coverage for the fees of qualified professionals related to the building’s design and restoration; it also covers the costs of recommissioning building systems and replacing vegetative roofs. Furthermore, the product is designed to respond to changes to the relevant rating system criteria or loss of anticipated rating points as a result of a covered loss.

Zurich insurance says that you have to look at potential exposures that are not usually covered by standard builder’s risk and property policies, but that may be unique for green buildings. According to Mike Halvey, Head of Real Estate Zurich North America Commercial, there are three elements that are the most important in “green” coverage. These are¹ as follows:

1. Betterment of the rating system

As the green movement continues to grow, the criteria by which a building can become certified by the U.S. Green Building Council may change. This can adversely affect real estate owners and developers as they may have designed their respective building using previous rating criteria. Zurich’s Better Green coverage for builder’s risk allows you to rebuild your building to the new criteria so you can still achieve your original desired certified status such as Silver, Gold, or Platinum LEED. With the property green coverage, if you lose your LEED certification that qualified you for government tax incentives, utility cost credits, reduced loan rates, or other financial incentives as the result of the loss of or damage to your property, we will pay for your actual loss sustained up to the aggregate limit on the endorsement.

2. Debris recycling

Most builder’s risk and property policies provide for debris removal. However, some of the LEED criteria require that debris be recycled either on the site or taken to a recycling center, which may be more

¹ Excerpted from “Green Buildings Insurance” online article (www.zurichna.com/zna/REALESTATE/greenbuildingsinsurancearticle.htm).

costly than utilizing a landfill. Zurich's endorsement offers a broader removal coverage providing for debris recycling and any associated additional costs.

3. LEED-accredited professional and building commissioning expenses

The LEED Green Building Rating System requires that qualified engineers help you with redesign or oversee the repair, rebuilding, or replacement of your building. As these professionals are not always on a contractor's staff, Zurich's endorsement would provide coverage for expenses incurred to hire a third-party engineer to assist. As a benefit to our customers, Zurich has risk engineers with LEED-accredited professional designations who can also provide recommendations to ensure that your project is being built to the green standards. Zurich will pay for these expenses and losses up to the aggregate limit provided for under the endorsement.

J.R. Steele, an attorney and LEED AP, points out,² “Since green construction, and especially large-scale green construction, is a fairly new phenomenon in the United States, there is very little legal analysis regarding green building disputes. Oftentimes, the problem faced by green building contractors, owners, and design professionals—especially those new to green construction—is that they fail to recognize that there are differences between a “normal” construction project and a green building project. Consequently, parties to green building contracts often rely on standard contracts that do not necessarily address the risks unique to green building projects. Failing to recognize those risks within the contract creates the potential for disputes and litigation down the road. Therefore, one of the keys to a successful green building project is to recognize and deal with the risks of that particular project.” J.R. Steel cites as examples of some of the unique risks parties to green construction projects often fail to address include the following:

- Defining which party is responsible for administrating the LEED certification process, which can be a time-consuming process;
- Defining who is responsible if the project fails to achieve LEED certification and what sort of damages flow from such a failure;
- Confirming that there is adequate insurance coverage, including professional liability insurance for design professionals, that takes into account the green nature of the project;

² This excerpt is from “Green Construction: Initiatives and Legal Issues Surrounding the Trend” in *Business Law Today*, 17 (2), 2007.

- Checking warranty and guaranty language to confirm that new green construction procedures or installation materials and/or techniques do not void the warranty or guaranty for a product;
- Dealing with long-term performance goals and length of warranty issues;
- Determining if any intellectual property infringements will result from utilizing new green techniques or equipment and who is responsible for dealing with any infringement that may arise;
- Investigating availability of green construction material and the replacement price for such material; and
- Recognizing the length of time and inspection process associated with LEED certification in the project construction schedule.

From the above examples, it is clear that there are various issues that parties participating in green building projects need to address. J.R. Steel emphasizes that in the end, the parties that will most likely succeed in avoiding costly litigation are the parties that emphasize open communication, clearly define performance expectations, fully examine the risks of the green project, and deal with these issues in their contract.

Indeed, the insurance industry as a whole needs to follow the lead of these “enlightened” insurance companies and embrace green building practices. In some cases, this may require the creation of new add-ons to current policies (which we have already started to see), but what is needed is a more institutional change in valuation and risk assessment that takes into account the sustainable quality of a building project as well as its potential positive impact on the environment. Many of these problems arise when building owners, designers, and builders differ in their interpretation of what constitutes a successful green building, and particularly when building owners fail to explicitly communicate their thoughts at the commencement of the project. Issues of this kind are compounded when the parties are relatively new to the concepts of the green building process.

Two of the main areas that typically need to be addressed are as follows: (1) A building’s failure to achieve a promised level of green building certification and (2) A building’s operational performance. In considering a building’s operational performance, there is some expectation that green buildings will, in addition to reducing environmental impacts, also reduce energy and water costs, require less maintenance and other long-term benefits to the building owner. The point to note however is that while a design may incorporate a wide range of green features, there are numerous considerations between a building’s design and occupancy that can invariably impact the building’s operational performance.

Legal actions may be brought against the building owner/developer, the builder, the professional consultant (e.g., architect or engineer), or the product manufacturer. Sometimes an expert may be used in the pretrial stages, possibly to give an affidavit supporting one or more issues of the case. The expert may also serve solely as an expert witness at trial or the expert may play a combination of these roles. There are also times when an expert will serve solely as a consultant to the lawyer and remain in the background.

One of the important principles by which insurance contracts are governed is the element of good faith. This basically implies that there is a duty on any entity taking out insurance to disclose all material facts and to expeditiously notify the insurer of any events that may lead to a claim. Indeed, the most common problems relating to insurance policies are the failure by a party to make full disclosure of all material facts when taking out a policy and failure to promptly notify possible claims. Insurers seek out any breaches of this duty to try and avoid liability. Also, an insured is required to have an “insurable interest” in the subject matter of the insurance; otherwise the insurance policy is typically considered to be null and void. The insurable interest may pertain to an interest in property or pertain to a liability or potential liability; for example, damages caused by negligence or breach of contract.

This is why the insured can usually recover only what has actually been lost and based on the indemnity principle does not permit to legally make a profit out of the insurance policy. Connected to this indemnity principle is the concept of subrogation, which basically allows the insurer to take over any claims that the insured might have in place against third parties and to receive any payments or compensation made to the insured by third parties. In many instances, insurance policies, construction contracts, and certificates will include what is known as a “waiver of subrogation” (also known as a “transfer of rights of recovery”). This is essentially a process by which insurers are able to transfer risk and to limit the rights of recovery from another party on behalf of the insured. Lawyers often advise their clients to have it built into their policy so that there is not a possibility that they are in breach of contract by forgetting to have it endorsed separately for every job requiring it. Whatever the case, it is strongly advised that prior to finalizing an insurance policy an attorney is consulted. Policies are frequently vague or inconsistently worded and may contain exclusions that limit their usefulness, and therefore parties taking out insurance should always carefully consider the policy wording to ensure that it adequately serves its purpose.

ENGAGEMENT LETTER

THIS AGREEMENT is made this ____ day of _____, 2016, by and between XYZ Capital Management, LLC (“Client”), and _____ (“Consultant”), who agree as follows:

- 1. Parties.** Client is real estate investment advisor for one or more institutional investors (the “Investor”) and has recommended that Investor acquire _____ located at _____ (the “Property”). Client wishes to retain Consultant to provide technical services to Client. Investor will be the beneficiary of the services provided by Consultant. The services performed by Consultant pursuant to this Agreement shall be performed under the direction and management of _____ or such other person selected by Consultant, subject to written approval by Client.
- 2. Scope of Work.** Exhibit A attached hereto contains the scope of the work to be performed by Consultant under this Agreement. Consultant represents that such work shall be carried out in a manner at least equal to industry standards and good commercial practices of reputable architectural and engineering firms for performing similar work. Consultant shall perform its services hereunder in full compliance with federal, state, and local laws and regulations, if any there be, which apply to such performance and are in effect at the time thereof.
- 3. Term.** Consultant shall use its best efforts to complete its Final Report (the “Report”) on or before _____. The term of this Agreement shall commence on the date hereof and shall continue until issuance of the Report. Client shall have the right to terminate this Agreement, at any time, in its sole discretion and with or without cause, by written notice to Consultant. Consultant shall stop work immediately upon receipt of a notice of termination and promptly deliver to Client the results of Consultant’s work to the date of termination. Client will compensate Consultant for work performed prior to the termination (including reasonable costs incurred in connection with termination) in accordance with Paragraph 4 hereof. This right to terminate shall be in addition to, and not in lieu of, any other rights and remedies Client may have at law or in equity.

- 4. Compensation.** The compensation for Consultant's performance of the work described in Paragraph 2 above shall be on a Lump Sum Basis. The Consultant shall receive an amount not to exceed _____ Dollars and NO/100s (\$ _____) for the work, which amounts shall include any and all costs associated for the work to be performed hereunder. The Consultant shall not receive any amount over that set forth above unless otherwise agreed to in writing by Client. The Consultant shall invoice Client upon completion of the Final Report. The invoice shall itemize and describe the services performed and identify personnel performing the services and the time expended. Payment shall be due not later than 60 days after receipt. The Consultant will maintain full and accurate records and books of account necessary to document: (1) all activities undertaken by or on behalf of Consultant in the course of performing services hereunder, and (2) all charges, expenses and disbursements incurred by Consultant, its agents or subcontractors in performing services hereunder. The Consultant will make such books and records available to Client upon prior written request during normal business hours.
- 5. Report.** At the conclusion of Consultant's tests, studies, investigations, and analyses for each phase of the work. Consultant shall prepare a written report (the "Report") summarizing the findings of Consultant's investigations, indicating areas of concern and potential problems, recommending suggested courses of remedial action and estimating the costs of such remedial action. Consultant shall provide 2 copies of the Report to Client. The Report shall be provided to Client in a draft form subject to Client's comments and review. No Report shall be considered final unless it is reasonably satisfactory to Client. No Report shall be considered unsatisfactory because it contains factual information which, while accurate, Client is dissatisfied with. Once Client is satisfied with the Report for each phase of the work the same will be put in final form (the "Final Report"). Six complete copies of the Final Report shall be provided to Client.
- 6. Further Work.** If, during the course of Consultant's investigations, Consultant discovers any fact or condition which would lead Consultant to recommend further inspection, testing or analyses, Consultant shall contact Mr. John Doe at (212) 445-0209 and discuss Consultant's findings and recommendations and give an estimate of the cost of such further work. The Client may authorize Consultant to perform such additional work by a letter to Consultant specifying the work to

be performed and the maximum additional fee to be added to the amount authorized in Paragraph 4 above. In no event shall Consultant be responsible or liable for any costs, damages, claim, or other consequences arising out of Client's decision not to accept Consultant's recommendation for further work.

- 7. Confidentiality.** The Consultant shall keep strictly confidential any information disclosed to the Consultant by Client, Investor or Investor's advisors, agents, or contractors. The Consultant shall not intentionally disclose to any third party the nature or results of, or any conclusions from, any work performed by Consultant under this Agreement without first obtaining the written consent of Client. This prohibition shall not preclude the Consultant from any disclosure of confidential information which is required by law or which is the result of lawful court order or other legal process so long as Consultant notifies Client of such disclosure as soon as practical. The Consultant shall notify any third party to which a disclosure is permitted to be made that the information disclosed is confidential and that the third party shall maintain such confidentiality. No news release, public announcement, denial, or confirmation of any part of the subject matter of this Agreement, or any information obtained pursuant hereto, shall be made without Client's prior written consent. All third-party inquiries shall be directed to Client. These confidentiality provisions do not apply to any information which, without fault on the part of Consultant, is generally known by or available to the public.
- 8. Insurance.** The Consultant is an independent contractor and not an agent, servant or representative of Client or Investor. The Consultant represents and warrants that it shall, at all times during the term of this Agreement, maintain workers' compensation insurance at minimum statutory limits and commercial general liability insurance in an amount not less than One Million Dollars (\$1,000,000.00) each occurrence, and professional liability errors and omissions insurance in an amount not less than One Million Dollars (\$1,000,000.00). The Consultant shall supply Client with certificates evidencing such insurance, adding the parties shown in Exhibit "C" hereto attached as additional insureds under the commercial general liability insurance with respect to the services to be performed by Consultant, and providing for thirty (30) days' written notice to Client prior to cancellation or modification thereof.

- 9. Attorneys' Fees.** If any legal proceeding is commenced between the parties with respect to the subject matter of this Agreement, the successful party in such proceeding shall be entitled to reasonable attorneys' fees and court costs to be determined by the court.
- 10. Indemnification.** The Consultant shall, with respect to all work which is covered by or incidental to this Agreement, indemnify and hold Client and Investor harmless from and against any and all claims, liability, loss, damage, costs or expenses, including reasonable attorneys' fees, awards, fines or judgments, resulting from death or bodily injury to persons, injury to property or other loss, damage or expense, arising from Consultant's negligence. Consultant's liability shall be limited to injury or loss caused by the negligence of Consultant, its subcontractors and/or agents hereunder and shall not exceed One Million Dollars (\$1,000,000).
- 11. Acceptance of Risk.** Consultant recognizes that, in performing work pursuant to this Agreement, its employees and subcontractors may be working with, or be exposed to, substances or conditions which are toxic or otherwise hazardous and hereby assumes all risks associated therewith, foreseen and unforeseen. Client shall notify Consultant of any known hazardous conditions prior to commencing work.
- 12. Governing Law.** This Agreement shall be covered by and construed under the laws of the State of Illinois.
- 13. Entire Agreement; Modification; Waiver.** This Agreement and the work authorizations to be issued by Client hereunder constitute the entire agreement of the parties and supersede any and all prior or contemporaneous written or oral negotiations, correspondence, understandings, and agreements between the parties respecting the subject matter hereof. No supplement, modification or amendment to this Agreement, other than work authorizations issued by Client hereunder, shall be binding unless executed in writing by both parties. No waiver of any of the provisions of this Agreement shall be deemed, or shall constitute, a waiver of any other provisions, whether or not similar, nor shall any waiver constitute a continuing waiver. No waiver shall be binding unless executed in writing by the party making the waiver.
- 14. Assignment.** This Agreement shall be binding upon and shall inure to the benefit of the parties and their respective successors and assigns. Neither party shall be entitled to assign any of its rights or obligations hereunder without the prior written consent of the other party, which may be withheld in such other party's sole discretion.

This Agreement consists of these three pages, plus Exhibits “A”, “B,” and “C” attached hereto and made a part hereof.



CLIENT

XYZ Capital Management, LLC

By: _____

Its: _____



CONSULTANT

By: _____

Its: _____



EXHIBIT “A”

Scope of Services

Issue a draft Report for review and discussion with XYZ Capital Management, LLC prior to issuance. Final Report will include description and opinions of the following information.



PLANS AND DOCUMENT REVIEW

- Completed Plans and Specifications
 - The written report will include Consultants opinion of whether the plans and specifications conform to generally accepted building construction practices.
 - Said report will also include Consultants opinion of whether the plans and specifications comply with all governing codes and zoning regulations. It is understood that consultant’s review is the only opinion and that actual compliance is the responsibility of the architect and/or engineers of records.
- Survey of plot including complete topography.
- Proof of conformance to building code.
- Zoning ordinances.
- Flood data.

- Subsurface soils investigation.
- Copy of building permit.
- Report to include Project Documentation Log listing plans received and other documents reviewed as a part of this assignment.
- Calculation of gross and leasable areas from plans.



BUILDING CONDITION REVIEW

- A description of the site improvement thereon, based upon field observation as well as review of the following information:
 - Architect and engineers inspection reports and final punch lists.
 - All testing and quality assurance reports.
 - All certifications of completion and acceptance by the architect and engineers of record.
- General conformance of visible construction of the building(s) and site development to the construction documents, soils report, and industry standards for such construction.
- Consultant shall list the codes, regulations, and public sector criteria with which the project must comply, including special permits, and other actions of local and state authority.
- Review of existing conditions of the building exterior, roof, owner-maintained interior spaces, owner maintained mechanical/electrical systems, site drainage, parking, landscaping, site utilities; with conclusions for conceivable repairs and deficiencies along with cost allowances for the suggested repairs.
- Appropriateness of the existing building materials found in place, with regard to the need for extraordinary maintenance or low-durability potential.
- General review of common area facilities for application of the Americans with Disabilities Act (ADA) and the general and living facilities for application of the Fair Housing Accessibility Guidelines (FHAA).
- Project observations noted including date of review and parties present.
- Provide photographs and description to more clearly define examples of unique features, overall building conditions, defective conditions, and potential repair/maintenance requirements as discussed in the report.
- Verification of the number of parking spaces by manual count.
- Consultant shall inspect a minimum of 10% of the interior of the total units within the apartment complex.

- The consultant's inspection team shall include professionals who have a full understanding of the various construction assemblies, systems, and materials used for the type of construction and building use identified above.



ACOUSTICAL TESTING

Review the STC ratings and assemblies of the common and party walls as shown on the construction documents to determine if the design conforms to the current building codes.

Provide necessary instrumentation and make measurements of sound isolation between adjacent units for two cases horizontal through a typical common party wall assembly and two cases vertically through a typical common floor assembly. This testing would follow procedures outlined in ASTM guidelines for standard test methods for measurement of airborne sound insulation in buildings (ASTM E-336 and E-413).

Make a visual examination of the existing conditions and compare observations against the building construction documents.

Prepare a report of findings.

The Building Condition Review will be performed to provide Client with a professional observation of existing condition visible on site. Destructive testing for access to concealed spaces nor the analysis of testing for the presence of noxious or toxic chemicals, or other elements including asbestos and PCBs, are not to be included in the services to be provided.



SEISMIC RISK ANALYSIS

For Buildings located in Seismic Zones III and IV, the consultant shall perform a seismic risk analysis to determine the Probable Maximum Loss (PML). The Consultant shall be licensed to practice structural engineering work and specializing in PML analysis work. Their scope of services is as follows:

Scope of Services

- Review plans and Specifications of the Property to determine the structural system used, the level of complexity of the property including building use, configuration, ornamentation, mechanical and electrical systems, and other unusual conditions that could effect the PML.

- Perform a site inspection to observe and document existing structural deficiencies and comment on the conformance of the building to the plans and specifications.
- Research and document historic earthquake records to compile a database of events of magnitude 4.0 or larger in the vicinity of the site. List each event showing the date of occurrence, location, distance from the site, maximum ground acceleration, Richter magnitude, and Modified Mercalli Intensity.
- Research geologic conditions specific to the site region. Document major faults and identify seismic hazards.
- Determine the **Maximum Probable Earthquake (MPE)** based on historic records, defined as the largest earthquake which has a 10% chance of being exceeded in a 50-year time period. This is also the Uniform Building Cod (UBC) design criteria for new construction.
- Determine the **Maximum Credible Earthquake (MCE)**, which is defined as the maximum ground motion that appears capable of occurring under the presently known geologic conditions.
- Determine the **PML** based on the MPE. Include backup calculations and reference the method used in the PML analysis.



EXHIBIT "B"

Consultant's professional and technical staff hours for additional services will be billed according to the following rates:

Principal ____/hr.

Architect ____/hr.

Engineer, P.E. ____/hr.

Technical/Research/Clerical Services ____/hr.

Should additional services be requested by Client, in addition to services outlined herein, Consultant will be entitled to additional compensation for such services on an hourly rate basis as noted above. Direct expenses such as travel, subsistence, reproduction of additional reports and express mail charges will be billed at the actual cost.

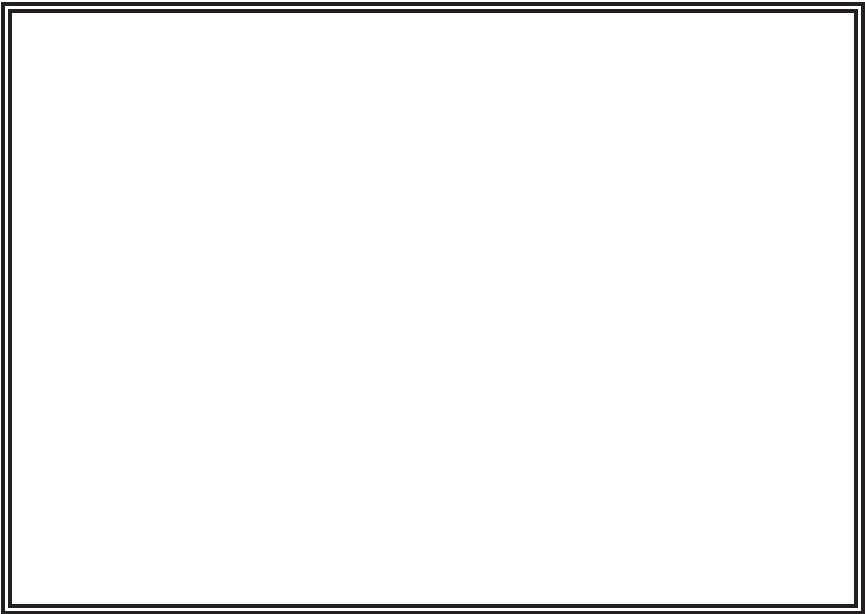

EXHIBIT "C"

Additional Insureds

PROJECT STATUS REPORT

Site Visit No. 5
Sample Project
South Salem, New York



February 14, 2016
ABC Project No. V5221

February 14, 2016

Mr. John Doe,
Assistant Vice President
Client, Inc.
222 Main Mall
White Plains, New York 12603
(914) 444-4444 (tel), (914) 444-4441 (fax)
(914) 444-4444 (tel)
(914) 444-4441 (fax)
Sent-by-Fax & U.S. Mail

Re: ABC Project No.V5221
Sample Project
South Salem, New York

Dear Mr. Doe:



A. STATUS OF CONSTRUCTION

The project was visited on February 12, 2016 by ABC International. A copy of the Borrower's Application No. 1, dated February 11, 2016, was received on February 12, 2016. At the time of our site visit, it was partly cloudy with the temperature about 55°F. Construction progress was as follows:

Site Work

The site work performed thus far includes the installation of the water, sewer, gas, electric and storm utility mains. Erosion control and wetland protection measures have been put in place and are being maintained. Construction of the entrance road asphalt base coarse is complete up to and including all parking for Building No. 2. Landscaping around the perimeter of Building No. 1 has been completed.

Building No. 1 (Units 1–5)

Work in this building is essentially complete except for the installation of carpeting, painting and appliances, which will be installed upon the sale of each unit.

Building No. 2 (Units 6–12)

The building exterior is complete with the asphalt shingles, doors, and windows, with vinyl siding and trim work-in-place. The interiors of each unit are in the process of being taped, spackled, and painted. Rough electrical

work is complete with finish electrical work progressing. The mechanical system is basically complete with final hook-ups in progress. Interior plumbing is essentially complete with fixture connections on-going.

Building No. 3 (Units 12–18)

The foundation and slab-on-grade has been cast and in-slab plumbing is in-place. No work has been performed during the period covered.



B. CERTIFIED VALUES OF WORK-IN-PLACE

Based upon our site visit of February 12, 2016, the Borrower's Application No. 9, dated February 11, 2016, (Exhibit "B") and supporting documentation, ABC has determined the current value of work-in-place to be as follows.

Direct Cost Budget	\$ 2,565,360.00
Adjustments (Authorized by PSB)	+ 0.00
Adjusted Direct Cost Budget	\$ 2,565,360.00
Total Value of Work Completed to-Date	\$ 890,088.82
Less Retainage	- 89,008.88
Total Completed Less Retainage	\$ 801,079.94
Less Previous Certifications	- 754,333.05
Current Certification	\$ 46,746.89
Cost-to-Complete Direct Cost Budget	
Including Retainage	\$ 1,764,280.06
ABC's Cost-to-Complete	
Including Retainage	\$ 1,866,894.06 (1)

(1) Based upon ABC's recommended budget of \$2,667,974.



C. ACTUAL CONSTRUCTION COSTS VERSUS DIRECT COST BUDGET

At this point in time, the project is presently 66% bought out and is within the direct cost budget of \$2,565,360; however, the Borrower has not submitted a cost report formatted similar to the loan budget. Of note, the Borrower has adjusted the line items located within the unit construction costs to reflect the actual contract amounts and changes in the scope of work documented within submitted invoices. In general, ABC finds the changes to be appropriate and acceptable to complete the scope of work outlined in the plans.

D. REQUISITION RETAINAGE

The Borrower's current application identifies that 10% retainage being withheld on the value of work-in-place.

E. QUALITY OF CONSTRUCTION

Overall, the quality of construction to date is satisfactory and is in general conformance with the construction documents reviewed by ABC. During our site visit, we did not observe any significant areas of unsatisfactory workmanship regarding the construction. In addition, construction has been performed in accordance with generally accepted construction industry standards.

F. WAIVERS OF LIEN

ABC has received a single combined waiver of lien executed by each of the trade contractors receiving payment during the previous period (Exhibit "C").

G. CHANGE ORDERS

During the PC, no change orders were provided for our review.

H. CONSTRUCTION PERMITS

ABC has received a building permit for Building No. 1 issued May 24, 2015 and a building permit for Building No. 2 issued September 12, 2015. According to the Borrower, a foundation permit has been issued by the City of North Salem but not received for Building No. 3. This permit will be forwarded to ABC upon receipt by the Borrower.

I. CERTIFICATES OF OCCUPANCY ("CO")

During the PC, ABC has received two (2) COs (Exhibit "D") issued by the South Salem, New York Department of Buildings dated October 25, 2015, both for Unit No. 2 located within Building No. 1. CO No. 25862 approves for occupancy a single family condominium with a finished basement family room, and CO No. G-25468 approves for occupancy a one (1) car garage and an unfinished basement with laundry area. To date, ABC has received COs for Unit Nos. 2, 4, and 5 located within Building No. 1.



J. AS-BUILT SURVEY

IVI has received an as-built survey from Surveying Associates, P.C., dated November 15, 2015 identifying the location of Building No. 1, 2, and 3. ABC has reviewed the site plan and has confirmed that the constructed location corresponds to that planned.



K. CONSTRUCTION SCHEDULE

ABC has received and reviewed the trade-by-trade construction schedules submitted by the contractor for Building Nos. 2 and 3. According to the schedules and based upon site observations, it appears that construction of Building No. 2 is approximately 1 week behind schedule. In addition, construction of Building No. 3 has not yet begun and is approximately 7 weeks behind schedule. ABC recommends that we receive a schedule update to reflect the current construction status.



L. OUTSTANDING DOCUMENTATION

- Foundation Permit for Building No. 3;
- Additional Building Permits (as issued);
- Updated Construction Schedules;
- Executed Subcontracts (on-going); and
- Certificates of Occupancy (as issued).

If you have any questions, please contact me at (914) 644-1999.

Sincerely,

ABC INTERNATIONAL

Robert Doe, Jr.
Project Manager

RD/sk

Attachments

Reviewed by: _____
Sam Kubba, R.A., LEED AP
Vice President

PARTIAL WAIVER OF LIENS

Project Description: _____

 Period Ending: _____, 201__
 Work Performed: _____
 Work Performed by: _____
 Under Contract to: _____
 Contract Date: _____
 Original Contract Amount: \$ _____
 Change Order Amounts: + _____
 Adjusted Contract Amount: \$ _____
 Work Completed to Date: \$ _____
 Less Retainage Not Yet Due: - _____
 Net Amount Due to Date: \$ _____
 Less Payments Received to Date: - _____
 Total Payment Due: \$ _____

THE UNDERSIGNED (1) acknowledges receipt of the amount set forth above as payments received to date, (2) to the extent of such payments, waives and releases any claim which it may now or hereafter have upon the land and improvements described above in the project description, (3) that the amount of payments received to the date of this waiver represents the current amount due in accordance with our contract and work completed, and (4) warrants that it has not and will not assign any claims for payment or right to perfect a lien against such land and improvements and warrants that it has the right to execute this waiver and release.

THE UNDERSIGNED further warrants that (1) all workman employed by it or its subcontractors upon this Project have been fully paid to the date hereof, (2) all materialmen from whom the undersigned or its subcontractors have purchased materials used in the Project have been paid for materials delivered on or prior to the date hereof, (3) none of such workman and materialmen has any claim or demand or right of lien against the land and improvements described above, and (4) stipulates that he is an authorized officer with full power to execute this waiver of liens.

THE UNDERSIGNED agrees that _____ and any lender and any title insurer may rely upon this waiver.

By _____
 Title _____

Sworn to me this ____ day
 of _____, 201__.

 Notary Public

NOTE: Return four (4) signed releases to _____ at _____, _____, _____, _____ to the attention of _____. Additional payments will not be made until the signed releases are returned.

FINAL WAIVER OF LIENS

Project Description:

Contract Date:
 Work Performed:
 Work Performed by:
 Under Contract to:

Listed below is the final information regarding the above contract:

Contract Price	\$ _____
Net Extras/Deductions	+ _____
Adjusted Contract Price	\$ _____
Amount Previously Paid	- _____
Balance Due-Final Payment	\$ _____

The undersigned, being duly sworn, deposes, certifies and says that:

(i) He (She) is an officer of, and is duly authorized to make this affidavit, waiver and release on behalf of _____ ("Contractor").

(ii) Contractor has received in full all payments (plus applicable retention) due through the date of this instrument for all labor, services, equipment and materials (sometimes referred to as the "work") furnished to _____ ("Owner") on the job of above project.

(iii) Contractor has paid in full or otherwise satisfied all of its obligations for labor, materials, equipment and services and all other indebtedness associated with the performance of Contractor's work on the Project, including without limitation payment in full to, or other satisfaction of, all persons and entities (the "Subcontractors") which have furnished labor, services, equipment or materials to Contractor.

(iv) In consideration of the payments received, and upon receipt of the applicable retention, Contractor forever waives, releases and relinquishes any and all claims and rights to a mechanic's lien, stop notice, bond right, equitable claim or right to any fund, and right to a labor and material bond or other bond on the Project and all other rights and claims that Contractor has on the Project.

(v) Contractor guarantees to Owner that the work furnished by Contractor (including work furnished by the Subcontractors) on the Project is and, after receipt of the applicable retention, shall be lien free, that the Subcontractors have no right to any mechanic's lien, stop notice, bond right, equitable claim or right to any fund, any right to a labor and material bond or other bond on the Project or other rights and claims with respect to the Project, and Contractor agrees to indemnify _____ and _____ against any claim or lien asserted through or under Contractor with respect to the Project, including without limitation any claim or lien asserted by any person who has furnished labor, materials, equipment or services to Contractor.

(vi) The undersigned further guarantees that all portions of the work furnished and installed by them are in accordance with the contract and that the terms of the contract with respect to these guarantees will hold for the period specified in said contract.

Sworn to me this ____ day of _____, 201__.

 By _____
 Title _____

Notary Public

NOTE: Return four (4) signed releases to _____ at _____, _____ to the attention of _____.

Payment will not be made until the signed releases are returned.

ABC INTERNATIONAL

105 Max Avenue
Suite 100
Leesburg, Virginia 20176

BUILDING DEPARTMENT INFORMATION REQUEST

Date: _____ To: John Doe
Subject: _____ Dept.: Building Official
_____ Loudon County Building Inspector
_____ Tel. No.: (703) 777-7777
_____ Fax No.: (703) 771-7771
Sender: _____ ABC Proj.
_____ No.: _____

New York Washington, D.C. Los Angeles Miami Virginia
(914) 694-9999 (tel) (202) 907-9999 (tel) (818) 896-9999 (tel) (305) 358-9999 (tel) (703).358-9999 (tel)
(914) 694-9991 (fax) (202) 907-9991 (fax) (818) 896-9991 (fax) (305) 372-9991 (fax) (703).358-9991 (fax)

ABC International has been commissioned to conduct a Property Condition Assessment Survey on the above referenced Subject. Please respond to the following documentation/information requests:

- 1. Does the Subject have any material outstanding building code violations within its file? Yes No
If "Yes", please fax copies of same.

- 2. Is there any existing or pending material building or fire/life safety code requirements that the Subject would not be grandfathered and therefore compliance would then be mandatory? If "Yes", please briefly explain. Yes No

- 3. Do you have any general or specific knowledge of any physical conditions (site or building) that negatively impact the Subject such as localized flooding, sanitary sewer back-up problems, etc.? If "Yes", please briefly explain. Yes No

- 4. Is the Subject within a 100 year frequency flood plain? If "Yes", please identify the Flood Hazard Zone as per FEMA's Flood Insurance Rate Maps. Yes No

- 5. Please fax us a copy of the Subject's Certificate of Occupancy.

Thank you for your assistance. Should you have any questions or should there be any fees associated with providing the requested information, please call me.

ABBREVIATED PROPERTY CONDITION REPORT

**Remington Apartments
2100 Stanford Square
Dulles, Virginia
XYZB Customer No. V36358**

**Prepared for:
XYZ National Bank
Charlotte, North Carolina**

**October 21, 2015
ABC Project No. V76817**



1. PURPOSE AND SCOPE

1.1 Purpose

ABC International, Inc. (“ABC”) was retained by XYZ National Bank (“XYZB”) to render an opinion as to the Subject’s current, general physical condition as of the day of our site visit in general accordance with the scope and terms of our agreement with XYZB.

XYZ National Bank and its affiliates (collectively, “XYZB”), rating agencies and certain limited investors involved in the Securitization (as defined below), may use and rely upon this appraisal in connection with a planned loan securitization involving the subject property (the “Securitization”), including, without limitation, utilizing selected information in the Report in XYZB’s Offering Memorandum relating to the Securitization and ABC agrees to cooperate in answering questions by any of the above parties in connection with the Securitization.

1.2 Scope

The scope of this survey included the following:

1. A single site visit consisting of a cursory, “walk-through” scan and a representative observation of apartment rental units and common areas; a survey for latent defects was not conducted.
2. Inquiries were made of the municipal building and fire department to determine whether there were any material-recorded code violations on file.
3. A brief review of any available construction or leasing documents/records.
4. The taking and annotating of photographs to document existing conditions, representative areas or systems, significant deficiencies, and/or evidence of deferred maintenance.
5. Preparation of opinions of probable costs, in accordance with the criteria herein, for work to remedy the material physical deficiencies observed and for a Modified Capital Reserve Schedule.



2. PROCEDURES AND PROTOCOL

2.1 Documentation Review

Upon being awarded this assignment, ABC issued a written request to the owner or his agent to obtain certain documentation to review on behalf of XYZB, which was intended to serve as an aid for our survey. The Documentation and Information Checklist and a Presurvey Questionnaire and Disclosure Statement were forwarded to the Subject’s ownership for reply to ABC. Refer to the Exhibits for copies of these documents.

ABC’s Presurvey Disclosure Questionnaire and Document and Information Review Checklist (the “Checklists”) were not returned to our office by the owner. The Checklists also inquired of latent defects, the discovery of which is beyond the scope of this survey, historical repairs, and improvements. This information was to assist our research to discover chronic problems, the extent of repairs and their costs, pending repairs and improvements, and existing physical deficiencies.

2.2 Site Visit

The site visit consisted of a visual walk-through survey of the Subject's easily accessible and readily observable areas to note significant deferred maintenance and the general condition of major components and systems. Mechanical and electrical equipment not normally operated by residents was neither operated nor tested by ABC, and nor was any exploratory probing or dismantling of the Subject's components conducted. This was a nonintrusive visual survey.

2.3 Research and Interviews

Available on-site property management and maintenance personnel were interviewed by ABC to inquire about past repairs/improvements, pending repairs, and existing or chronic physical deficiencies. We also contacted and interviewed salient building service company personnel for the same aforementioned reasons. To the extent that XYZB, owner, service company personnel, or their representatives have provided information regarding the Subject's operation, conditions, quantities, and capacities, and that such information appears reasonable, ABC has taken the position that such information was correct and complete.



3. PROJECT IDENTIFICATION

Property name:

Address:

Remington apartments
2100 Stanford Square
Dulles, Virginia 20166

Site Visit Date:

July 21, 2015

Consultant:

John A. Doe
Project Manager



4. PROJECT SUMMARY

The following table summarizes the findings of the significant elements of this investigation.

Item	E	G	F	P	Action*	Immediate needs	Short term (0-1 year)	**Capital reserves
Site/site improvements								
Topography		X			NM			
Storm drain		X			NM			
Parking, paving, striping and sidewalks			X		IR/RR		\$1900	\$5600
Utilities		X			NM			
Landscaping		X			IR/RR		\$3000	\$2000
Site lighting		X			NM			
Site and building signage		X			NM			
Rec facilities/ Amenities		X			IR/RR		\$4200	\$3000
Structural frame and building envelope								
Substructure		X			NM			
Superstructure		X			NM			
Exterior walls-masonry					N/A			
Exterior walls-wood					N/A			
Exterior walls-stucco		X			IR	\$500	\$19,300	
Exterior walls-vinyl		X			NM			
Exterior walls-paint (includes windows, doors)		X			NM			
Windows and frames		X			NM			
Main doors and frames		X			IR	\$1000	\$1050	
Stairs (structural)		X			NM			
Roof coverings		X			NM	\$300		
Roof drainage		X			NM			
Mechanical, electrical & plumbing systems								
HVAC			X		RR			\$42,000
Electrical (wiring)			X		NM		\$500	
Electrical (panels)			X		NM			
Emergency lighting generator					N/A			
Hot and cold water distribution		X			NM		\$1500	
Hot and cold water distribution					NM			
Domestic water heaters			X		RR			10,725

Item	E	G	F	P	Action*	Immediate needs	Short term (0–1 year)	**Capital reserves
<i>Vertical transportation conveying systems</i>								
Elevators/Escalators					N/A			
<i>Fire/life safety</i>								
Fire extinguishers		X			NM			
Security alarm systems—comm'l					N/A			
<i>Interior elements</i>								
Common area finishes		X			NA			
Tenant area finishes <i>Carpet & vinyl & cabinets</i>		X			IR/RR		\$33,600	\$55,825
Appliances		X			RR		\$7200	\$3000
<i>“Barrier free” accessibility (ADA)</i>								
Ingress/Egress					X	NM		

Action*: *IR*, immediate repair/replacement; *NM*, normal maintenance; *RR*, replacement reserves, **Uninflated Values.

This table displays the estimated costs. The estimated costs are preliminary and are based upon ABC’s experience in conducting similar projects. The actual cost will be affected by factors such as project duration, site access, market conditions, and other contingencies applied by the owner. This project summary is not to be used alone. The attached report is intended to be read in its entirety.

Definitions:

Excellent:	New or like new
Good:	Satisfactory as is
Fair:	Satisfactory as is in general, however, may require short-term and/or immediate attention
Poor:	Requires immediate repair, replacement, or significant maintenance.



5. GENERAL DESCRIPTIVE INFORMATION

Remington Apartments (the “Subject”) consists of a rectangle-shaped parcel of land that totals approximately 1.92 acres. The Subject is currently developed for multifamily residential use with five 2-story, multifamily residential buildings that total approximately 39,440 sqft and containing 48

apartments; a single-story restroom/pool equipment building consisting of approximately 400 sqft; and a single-story laundry building consisting of ± 750 sqft also exist on site.

The property is accessed off of Stanford Square along the northern property boundary. An access drive also exists along the south side of the property along. This southern access drive is currently blocked by a gate since nonresidents were reportedly using the property as a convenient short cut. Landscaping consisting of grass, trees, and shrubs exists along the northern property line and the south side of the property. The majority of the asphalt paved parking and drives are located on the east side of the site. Parking is provided for approximately 30 cars in steel-framed carports, and another 60 spaces exist at grade in uncovered parking. Five spaces exist under two of the buildings in carports on the south side of the property.

All five residential buildings are constructed over concrete slab-on-grades, and although not visible, their foundations likely consist of conventional spread footings. All the buildings are of wood frame construction, and their exterior walls are covered with stucco. The two buildings on the south side of the property have hip style roofs that are covered with concrete tiles. The three buildings on the north side of the property have concrete tile mansards, and the flat portions of the roofs are covered with rolled mineralized roofing systems. All apartments are accessed from a private entrance at grade or a common area balcony. In addition, all apartments either have a private patio or balcony on the opposite side of the building from the front entrance.

Balconies are cantilevered extensions of the second levels' floor joists. The front common area balconies also have wood columns for further support. Rear private balconies are only cantilevered. All balconies are covered with plywood and a mineralized felt roof covering for protection from the elements.

Heating to the units is provided by individual natural gas furnaces manufactured by Payne. These units are typically located within a mechanical closet in every apartment. Air conditioning is provided by individual direct expansion (DX) units with exterior pad-mounted condensing units. The evaporator coils for the units are located within the closet-mounted furnace which acts the HVAC system's air handling unit. Conditioned air is then distributed in the apartment through the ductwork hidden in each apartment's central hallway ceiling for distribution to the various rooms. Domestic hot water is provided by individual gas-fired water heaters that typically have a capacity of ± 50 gallons. Hot water to the pool pumping equipment is provided by a gas-fired boiler. All piping was observed and was reported to be copper.

Electrical service is 800-amp, 120/240V, single-phase, service, and appeared to be adequate for the building and its current electrical load. Each unit is

individually metered for electricity, and the common areas are metered separately. All units are also individually metered for gas consumption.

The City of Dulles provides service to the Subject for domestic water and sanitary sewer. Dominion Power provides electricity, and natural gas is provided by Washington Gas. Storm water runoff from the property sheet flows to the service drive/parking area on the east side of the property and is discharged into the gutter along Stanford Square on the south side of the property.



6. GENERAL PHYSICAL CONDITION

Generally, the Subject was considered in poor to fair condition. It was evident from the survey that the Subject has been the recipient of a minimal amount of preventive maintenance. If the present level of preventive maintenance being provided is improved, and the few areas of deferred maintenance and existing physical deficiencies discussed herein are corrected, the property should continue to retain its ability to compete in the marketplace.

It is our opinion that the remaining useful life of the property can continue for its intended purposes for at least an additional 35 years if the recommended repairs in this report are made, the physical improvements receive continuing maintenance, and if the various components and/or systems are replaced or repaired in a timely basis as needed.

All materials faults and/or deficiencies observed which require immediate expense consist of the following:

- The exterior electrical closet's doors have fallen off and the buildings' switch gear, cable TV, and telephone wiring are exposed to the elements. Replacement of the doors is recommended.
- The two buildings on the south side of the property have grade-level carports. Lighting for this area is provided by fluorescent strip fixtures which are mostly broken and require repair. Replacement of severely deteriorated storage room doors and hardware is also warranted.
- Carport roofs are damaged in various areas as a likely result of vandalism and require repair and in some areas replacement.
- The pool's gas-fired boiler is broken and requires repair. Given its age and condition, replacement is likely warranted.
- The Subject's air conditioning condensing units are approaching the end of their expected useful lives. Given this scenario and the lack of preventive maintenance exercised over the years, it can be expected that numerous units will fail in the near future. Budgeting for these replacements is warranted.

- Finishes within the apartment units were excessively worn beyond their years and replacement of carpeting, resilient vinyl flooring, and cabinets can be expected in the beginning of the reserve term. Gas-fired ranges (the only major appliance provided by management) were also observed to be aged beyond their years, and replacement of numerous units can be expected in the reserve term.
- Mold has grown on numerous areas of the buildings' facades and dirt as splashed up on the lower portions of the building's elevations. Powerwashing of the building facades is recommended in the short term.
- Wood trim found on the buildings, and the first floor apartments' privacy screen fences are in need of painting.
- Several deteriorated areas were observed on the building's common area balconies. The superintendent has made "patch type" repairs to these areas with plywood. However, this is not a waterproof solution, and covering the areas with a membrane application which exists on the remainder of the balconies is warranted.



7. SUMMARY OF FINDINGS

In overall assessment, considering its age, use, and location; the condition of the buildings and site improvements is considered good.

There are a limited number of deferred maintenance items, which should be corrected as part of routine maintenance.

There are a number of immediate repairs/replacements required at this time as follows:

Immediate action item	Cost
Replace missing electrical closet doors	\$1000
Repair damaged stucco on building exteriors and paint	\$500
Remove tenant constructed canopies	—
Install membrane on areas of repaired balconies	\$300
Total	\$1800

Short term (YR 1) items	Cost
Seal coat parking lot, drives, and Re-stripe	\$1900
Repair and replace areas of damaged carport roofs	\$1200
Repair broken light fixtures at underbuilding parking	\$500
Replace deteriorated doors at underbuilding parking	\$900
Replace deteriorated door at pool pump house	\$150
Powerwash building facades	\$2500
Paint exterior stucco	\$16,800

Short term (YR 1) items	Cost
Landscape upgrades	\$3000
Replace pool water heater	\$1500
Paint exterior trim and patio screen fencing make repairs to fencing as needed	\$3000
Replace interior carpeting at damaged units (24 units \pm 50%) to include living and dining rooms	\$15,600
Replace damaged vinyl flooring in kitchens and baths (24 units \pm 50%)	\$3600
Replace deteriorated gas ranges (24 units \pm 50%)	\$7200
Replace Deteriorated Cabinets (26 units \pm 43%)	\$16,400
Total	\$72,250

Using a 2.5% inflation rate over a 12-year term, the estimated funding requirements for capital reserve expenditures are:

Factor	Aggregate	\$/SF/Year
Uninflated	\$122,150.00	\$0.26/SF/YR (\$212/Unit/YR)
Inflated @ 2.5%	\$143,920.00	\$0.30/SF/YR (\$250/Unit/YR)



8. CONSULTANT'S CERTIFICATION

On behalf of ABC International, Inc., I hereby certify that:

1. I have no present or contemplated future interest in the real estate that is the subject of this report;
2. I have no personal interest or bias with respect to the subject matter of this report, its ownership, management, or any of the Subject's service companies or vendors;
3. To the best of my knowledge and belief, any statement of fact contained in this report and any information provided by others, upon which my evaluation, opinions, and recommendations expressed herein are based, are true and correct;
4. The compensation received for this report is not contingent on any action or event resulting from the evaluations, opinions, recommendations, or the opinions of probable costs expressed herein or the use of this report;
5. This report was prepared to disclose observed existing conditions and for information purposes only. Neither I nor ABC warrant or guarantee the results of any of its opinions, information provided by others, or the adequacy of the opinions of probable costs provided to

remedy the Physical Deficiencies or for the Modified Capital Reserve Schedule; and

6. This Abbreviated Property Condition Assessment was prepared with the standard of care and skill ordinarily exercised by single-source due diligence construction consultants that specialize in conducting general overview, preliminary property condition assessment surveys of similar scope and purpose, in the same locality, under similar budget and time constraints on behalf of mortgagees for underwriting due diligence purposes.

John A. Doe
Field Observer



APPENDIX

**12 YEAR CAPITAL RESERVE TABLE
PHOTOGRAPHS
SITE VICINITY MAP
QUESTIONNAIRE
MISCELLANEOUS INFORMATION
XYZB CONTRACT**

PHOTO DESCRIPTIONS

- “Site”
- “Structural”
- “Exterior”
- “Roof”
- “Interior”
- “Plumbing”
- “HVAC”
- “Electrical”
- “Fire Protection/Life Safety”
- “Garages/Carports”
- “Elevators”
- “Amenities”
- “ADA”



PROPERTY CONDITION ASSESSMENT RESEARCH

- Fire Department
- Building Department
- Zoning Department
- Stewart Mortgage Information
- Property Owner/Manager
- Maintenance Supervisor
- Elevator Service Company
- Other Applicable Service Companies



EXHIBITS

- Representative Photographs
- Presurvey Questionnaire and Disclosure Schedule (w/responses)
- Document and Information Review Checklist (w/responses)
- Site Location Map
- Standard Flood Hazard Determination

- Building Department Freedom of Information Act Request (w/responses)
- Zoning Department Freedom of Information Act Request (w/responses)
- Fire Department Freedom of Information Act Request (w/responses)
- Elevator Service Company Research Letter (w/responses)
- Seismic Zone Map of the United States (if applicable)
- Certificate of Occupancy (if provided)
- Leasing Literature/Rent Roll (if provided)
- Capital Improvement Schedule (if provided)
- Grupo Expedicionários Capixabas de Rádio Emissão (GECRE)
Schedule 1: ADA Short-Form Checklist (GE only)
- GECRE Schedule 2: Guidelines for Capital Reserves Schedule (GE only)
- GECRE Schedule 3: Year 2000 Building Readiness Checklist (GE only)
- Other Applicable Exhibits



PROPERTY CONDITION REPORT PROJECT FILES (ORDER OF WORK FILES WITHIN A PROJECT FILE)

- 01 Property Condition Report Checklist YY-MMDD
- 02 PSQ YY-MMDD
- 03 PSQ Follow-Up Letter YY-MMDD
- 04 Fire Department Freedom of Information Act and similar state statutes (FOIA) Request YY-MMDD
- 04.1 Fire Department FOIA Request Follow-Up Letter YY-MMDD
- 05 FOIA Request Payment Letter YY-MMDD*
- 06 Building Department FOIA Request YY-MMDD
- 06.1 Building Department FOIA Request Follow-Up Letter YY-MMDD
- 07 FOIA Request Payment Letter YY-MMDD*
- 08 Zoning Department FOIA Request YY-MMDD
- 08.1 Zoning Department FOIA Request Follow-Up Letter YY-MMDD
- 09 FOIA Request Payment Letter YY-MMDD*
- 10 Elevator Service Company Information Request YY-MMDD*
- 11 Flood Hazard Determination Request YY-MMDD
- 12 Site Visit Confirmation Letter YY-MMDD
- 13 Site Visit Debriefing Letter YY-MMDD
- 14 Draft Report YY-MMDD
- 15 Photo Locator YY-MMDD

- 16 & 17 Draft Cost & Reserve Schedules YY-MMDD
- 18 Final Report YY-MMDD
- 19 Environmental Cross Reference Sheet YY-MMDD
- 20 GECRE Schedule 1—ADA Short-Form Checklist YY-MMDD*
- 21 GECRE Schedule 2—Guidelines for Capital Reserve Schedule YY-MMDD*
- 22 GECRE Schedule 3—Year 2000 Building Readiness Checklist YY-MMDD*
- 23 Insurable Value Schedule YY-MMDD*

Notes:

1. YY-MMDD=Year, Month, and Day file was created; Example:
December 31, 2015 = 15-1231
2. *=if applicable



Acronyms and Abbreviations



ORGANIZATIONS AND AGENCIES

AAEE	American Academy of Environmental Engineers
ACEEE	American Council for an Energy Efficient Economy
ADAAG	ADA Architectural Guidelines,
AFA	American Forestry Association
AIA	American Institute of Architects
ANSI	American National Standards Institute
APCA	Air Pollution Control Association
ASAE	American Society of Architectural Engineers
ASCE	American Society of Civil Engineers
ASHRAE	American Society of Heating, Refrigeration, and Air-conditioning Engineers
ASID	American Society of Interior Designers
ASME	American Society of Mechanical Engineers
ASNT	American Society for Nondestructive Testing
ASPE	American Society of Plumbing Engineers
ASTM	American Society for Testing and Materials
AWEA	American Wind Energy Association
BBRS	Board for Building Regulations and Standards
BCDC	Bay Conservation and Development Commission
BIFMA	Business and Institutional Furniture Manufacturer's Association
BLM	Bureau of Land Management
BOCA	Building Officials and Code Administrators
BREEAM	Building Research Establishment Environmental Assessment Method
CEC	California Energy Commission
CFR	Code Federal Regulation
CIBSE	Chartered Institution of Building Services Engineers
CIWMB	California Integrated Waste Management Board
CRI	Carpet and Rug Institute CRS—Center for Resource Solutions
CRS	Center for Resource Solutions
CSI	Construction Specifications Institute; Construction Standards Institute
CUWCC	California Urban Water Conservation Council
DoD	Department of Defense

DOE	U.S. Department of Energy
DPW	Directorate of Public Works
DWR	Department of Water Resources (CA)
EIA	Energy Information Administration
EPA	U.S. Environmental Protection Agency
ERDC	USACE Engineer Research and Development Center
ESI	European Standards Institute
FEMA	U.S. Federal Emergency Management Agency
FSC	Forest Stewardship Council
GBCI	Green Building Certification Institute
HUD	U.S. Department of Housing & Urban Development
IEA	International Energy Agency
IEEE	Institute of Electrical and Electronics Engineers, Inc.
IESNA	Illuminating Engineering Society of North America
IPMVP	International Performance Measurement & Verification Protocol
ISO	International Organization for Standardization
NAE	National Academy of Engineering
NAHB	National Association of Home Builders
NAS	National Academy of Sciences
NBI	New Building Institute
NCARB	National Council of Architectural Registration Boards
NFRC	National Fenestration Rating Council
NIST	National Institute of Standards and Technology
OEE	Office of Energy Efficiency
OSHA	Occupational Safety and Health Administration (or Act)
OSWER	U.S. EPA Office of Solid Waste & Emergency Response
SBIC	Sustainable Building Industry Council
SCAQMD	South Coast Air Quality Management District
SEC	Securities and Exchange Commission
SMACNA	Sheet Metal and Air Conditioning Contractors' National Association
UL	Underwriters Laboratories
USACE	U.S. Army Corps of Engineers
USDA	United States Department of Agriculture
USEPA	U.S. Environmental Protection Agency
USFS	U.S. Forest Service
USGBC	United States Green Building Council



REFERENCED STANDARDS AND LEGISLATION

ADA	Americans with Disabilities Act
ASHRAE 90.1	Building energy standard covering design, construction, operation, and maintenance
ASHRAE 52.2	Standardized method of testing building ventilation filters for removal efficiency by particle size
ASHRAE 55	Standard describing thermal and humidity conditions for human occupancy of buildings
ASHRAE 62	Standard that defines minimum levels of ventilation performance for acceptable indoor air quality
ASHRAE 192	Standard for measuring air-change effectiveness
ASTM E408	Standard of inspection-meter test methods for normal emittance of surfaces
ASTM E903	Standard of integrated-sphered test method for solar absorptance, reflectance, and transmittance
CAA	Clean Air Act; Compliance Assurance Agreement
CASBEE	Comprehensive Assessment for Building Environmental
CERCLA	Comprehensive Environmental Response, Compensation, and Liability Act
CERL	Construction Engineering Research Lab—part of USACE
CWA	Clean Water Act (aka FWPCA)
EISA	Energy Independence and Security Act of 2007
EPAct	Energy Policy Act of 2005
EPAct	U.S. Energy Policy Act of 1992
FCAA	Federal Clean Air Act
FFHA	Federal Fair Housing Act
FOIA	Freedom of Information Act and similar state statutes
GS	Green Seal
MERV	Minimum Efficiency Reporting Value
NFPA	National Fire Protection Association
PURPA	Federal Public Utilities Regulatory Policy Act of 1978
RCRA	Resource Conservation and Recovery Act
TSCA	Toxic Substances Control Act
UBC	Uniform Building Code: The International Conference of Building Officials model building code
USAID	United States Agency for International Development



ABBREVIATED GENERAL TERMINOLOGY

A	Area
A or AMP	Ampere
AAQS	Ambient Air Quality Standards
AC	Alternating current
A/C	Air conditioning unit
ACH	Air change per hour
ACM	Asbestos containing material
ACT AGE	Actual age
ADAAG	ADA Architectural Guidelines
AE	Architect–Engineer firm (typically contracted for design services)
AEI	Advanced Energy Initiative
AEO	Annual Energy Outlook, DOE/EIA publication
AF	Acre–foot (of water)
AFC	Application for certification
AFV	Alternative–fueled vehicle
AFY	Acre–feet per year
AGMBC	LEED–NC Application Guide for Multiple Buildings and On–Campus Building Projects (USGBC document)
AHM	Acutely hazardous materials
AHU	Air handling unit
AIB	Air infiltration barrier
AIRR	Adjusted internal rate of return
AL	Aluminum
APPA	America Public Power Association
AQMD	Air Quality Management District
AQMP	Air Quality Management Plan
ARB	Air Resources Board (CA)
ATC	Acoustical tile ceiling
A/V	Audiovisual
BAAQMD	Bay Area Air Quality Management District
BAS	Building Automation System: a Network of electronic devices that control mechanical and lighting systems
BC	Building code
Bcfd	Billion cubic feet per day
BEA	U.S. Bureau of Economic Affairs
BEEP	BOMA Energy Efficiency Program
BEES	Building for Environmental and Economic Sustainability Support
BG	Biomass gassification
BIM	Building Information Model

BIPV	Building integrated photovoltaics
BL	Building line
BM	Benchmark
BMP	Best Management Practices
BOD	Basis of Design: Design information necessary to accomplish the owner's project requirements
BOD	Beneficial Occupancy Date
BRI	Building-Related Illness
BT	Building Technologies
BTU	British Thermal Unit
BTUH	British Thermal Unit per Hour
BUR	Built-up Roofing
CAA	U.S. Clean Air Act
CAAQS	California Ambient Air Quality Standards
CalEPA	California Environmental Protection Agency
CAPM	Capital Asset Pricing Model
CARB	California Air Resources Board
CBC	California Building Code
CBECs	Commercial Building Energy Consumption Survey
CD	Construction Division
CDVR	Corrected Design Ventilation Rate
CEERT	Coalition for Energy Efficiency and Renewable Technologies
CEU	Continuing Education Unit
CFCs	Chlorofluorocarbons: Ozone-depleting constituent of the most widely used HVAC refrigerants
CFM	Cubic feet per minute
CFR	Code of Federal Regulations
CFS	Cubic feet per second
CHPS	Collaborative for high-performance schools
CIR	Credit Interpretation Ruling—published USGBC answers to interpretation questions on individual credits from project teams pursuing project LEED certification
CO ₂	Carbon dioxide
CO	Carbon monoxide
COC	Chain-of-Custody: Proper accounting of materials flows, as used by the FSC
COS	Center of Standardization
CMBS	Commercial Mortgage-Backed Securities
CMU	Concrete Masonry Unit
CPG	Comprehensive Procurement Guidelines
CSA	Canadian Standards Association
CWA	Clean Water Act
CxA	Commissioning Authority: An independent representative who guides the commissioning process
dB	Decibel

DB	Design-Build single contract
DBB	Design-Bid-Build
DC	Direct current
DEC	Design Energy Cost
DHWH	Domestic hot water heater/Water heater
DOC	Determination of compliance
DOR	Designer of record
DPB	Discounted payback
DPTN	Demountable partitions
DS	Daylight sensing control; Disconnect switch; Downspout
DW	Drinking water; Drywall
E	Each; East; Modulus of elasticity
E&C	Engineering & Construction
ECB	Engineering and Construction Bulletin
ECBEMS	Energy Management System
ECMs	Energy Conservation Measures
EER	Energy Efficiency Ratio
EFF AGE	Effective age
EIA	Energy Information Administration
EIFS	Exterior Insulation & Finish System
EIR	Environmental Impact Report
EIS	Environmental Impact Statement
EL	Easement line; Elbow
EL, ELEV	Elevation
EMCS	Energy Monitoring and Control System
EMF	Electro Magnetic Fields
EMP	LEED Energy Modeling Protocol
EO	Executive Order
EPCA	Energy Policy and Conservation Act
EPDM	Ethylic-Propylene Diene Monomer
EQP, EQUIP	Equipment
ESA	Environmental Site Assessment
ESC	Erosion and Sedimentation Control Plan
ESP	Energy Service Providers
ETS	Environmental Tobacco Smoke
EUL	Expected Useful Life
FAU	Forced Air Unit
FEMP	Federal Energy Management Program
FERC	Federal Energy Regulatory Commission
FF&E	Finishes, furniture (fixtures) & equipment
FFL	Finished floor line
FIO	For information only
FIX	Fixture
FOIL	Freedom of Information Letter
FS	Full scale; Full size; Federal specification

FSC	Forest Stewardship Council
ft. ² /ft. ³	Square feet (foot)/cubic feet (foot)
FTC	Federal trade commission
FTE	Full time equivalent
FTE	Full time employee
FTG	Footing
FY	Fiscal year
GBI	Green Building Initiative
GC	General Contractor
GDP	Gross Domestic Product
GEP	Good Engineering Practice
GF	Glazing factor
GHG	Greenhouse gases
GIS	Geographic Information System
gpd	Gallons per day
gpf	Gallons per flush
gpm	Gallons per minute
GRD, GD, G	Grade
GW	Gigawatt
GW(h)	Gigawatt (hour) = 1 billion watts
GWP	Global Warming Potential
GYP	Gypsum
GYP BD	Gypsum board
H ₂ S	Hydrogen sulfide
HAZMAT	Hazardous materials
HBD, HDB	Hardboard
HCFCs	Hydrochlorofluorocarbons: Alternative refrigerant type that has reduced ozone-depleting effects
HFCs	Hydrofluorocarbons: Alternative refrigerant with no ozone-depleting effects but some trade-offs
HP	Horse power
HRA	Health Risk Assessment
HT	Height
HV	High voltage
HVAC	Heating, ventilating, and air conditioning
HVAC&R	Heating, ventilation, air conditioning, and refrigerants
HWD	Hardwood
HZ	Hertz
IAQ	Indoor Air Quality
IDG	Installation Design Guide
IEPR	Integrated Energy Policy Report
IEQ	Indoor Environmental Quality—one of the six LEED credit categories
IFMA	International Facilities Management Association
IN	Inch(es)

INFO	Information
INSUL	Insulate (ion)
IPCC	Intergovernmental Panel on Climate Change
IPLV	Integrated Part Load Value
IRR	Internal Rate of Return
ISO	Independent System Operator
kg	Kilogram
KIT	Kitchen
km	Kilometer
kw(h)	Kilowatt (hour) = 1000 watts
kv	Kilovolt
kVA	Kilovolt-Ampere (transformer size rating)
kVAR	Kilovolt-Ampere Reactive
kw	Kilowatt
LADWP	Los Angeles Department of Water and Power
LAN	Local Area Network
LAV	Lavatory
LBNL	Lawrence Berkeley National Laboratory
lbs	Pounds
lbs/hr	Pounds per hour
LCA	Life Cycle Assessment
LCC	Life Cycle Cost
LCCA	Life Cycle Cost Analysis
LCGWP	Life-Cycle Global Warming Potential
LCODP	Life-Cycle Ozone Depletion Potential
LD BRG	Load bearing
LEED	Leadership in Energy and Environmental Design (USGBC)
LEED AP	LEED Accredited Professional
LEED-EB	LEED tool for Existing Buildings
LEED Homes	LEED tool for homes
LEED-NC	LEED tool for New Construction & Major Renovations
LEED ND	LEED tool for Neighborhood Development
LE/FE	Low-emission/Fuel-efficient vehicle
LID	Low Impact Development
LL	Live Load
LPG	Liquefied petroleum gas (propane and butane)
LQHC	Low quality hydrocarbons (i.e., tar sands and oil shale)
LR	Living room
LTV	Loan-to-value
LV	Low voltage
LVL	Level
LW	Lightweight
LZ	Lighting Zone
M, m	Meter, Million, Mega, Milli or Thousand

MAIN	Maintenance
max	Maximum
MDF	Medium Density Fiberboard
MEP	Mechanical, Electrical, and Plumbing
MERV	Minimum Efficiency Reporting Value
M/F Ratio	Male/Female ratio
MMT	Million metric tons
MOU	Memorandum of understanding
MR	Moisture resistant
m/s	Meters per second
MSDS	Material Safety Data Sheet
MV	Megavolt
MVA	Megavolt-amperes
MW	Megawatt (million watts)
MWD	Metropolitan Water District
MWh	Megawatt (hour) = 1 million watts
N	North
NAAQS	National Ambient Air Quality Standards
NC	New Construction
NCPA	Northern California Power Agency
NEMA	National Electrical Manufacturers Association
NEPA	National Environmental Policy Act (federal “equivalent” of CEQA) of 1969
NES	National Energy Savings
NG	Natural Gas
NO ₂	Nitrogen dioxide
NO	Nitrogen oxide
NO _x	Nitrogen oxides
NOM	Nominal
NPDES	National Pollutant Discharge Elimination System
NPV	Net present value
NS	Net savings
NTS	Not to scale
O ₃	Ozone
OC, O/C	On Center
O&M	Operation and Maintenance
ODP	Ozone depleting potential
OH, OVHD	Overhead
OPR	Owner’s Project Requirements Document
OSA	Outside air
OSB	Oversight Board
oz	Ounce
PBD	Particleboard
PBP	Payback period
PCA	Property Condition Assessment

PCC	Precast Concrete
PDT	Project Development Team
PFL	Pounds per Lineal Foot
PL	Property Line
PM	Project Manager
PML	Probable Maximum Loss
PMO	Project Management Oversight
POC	Point of contact
ppm	Parts per million
ppt	Parts per thousand
PRM	Performance Rating method
psf	Pounds per square foot
psi	Pounds per square inch
PTO	Permit to Operate
PU	Per unit
PUC	Public Utilities Commission
PV	Solar photovoltaics
PV	Present Value
PV	Photovoltaic
PVC	Polyvinylchloride
QA/QC	Quality Assurance/Quality Control
qty	Quantity
R, RD	Radius
RA	Return Air
Rc	Refrigerant Charge
RD&D	Research, Development, and Demonstration
REC	Renewable Energy Certificate
Ref	Reference
Reinf	Reinforcement
Req	Requirement, Required
Rev	Revision
RFP	Request for Proposals
RFQ	Request for Qualifications
RH	Relative Humidity
RTU	Rooftop package unit
RUL	Remaining useful life
S, SW	Switch
SA	Supply air
San	Sanitary
SBS	Sick Building Syndrome
SBTF	Sustainable Building Task Force (CA)
Sch, Sched	Schedule
SD	Smoke detector; Shop drawings; Storm drain; Supply duct
SEER	Seasonal Energy Efficiency Ratio
sf, sq ft	Square foot (feet)

Sftwd	Softwood
SHGC	Solar heat gain coefficient
SIR	Savings-to-Investment ratio
SOG	Slab-on-Grade
SO _x	Oxides of sulfur
SO ₂	Sulfur dioxide
SO _x	Sulfur oxides
SOW	Scope of work
SPB	Simple payback
SPIRIT	Army developed point/credit-based system for measuring sustainability of buildings/development (modified version of LEED version 2.0)
SRI	Solar Reflectance Index
STC	Sound Transmission Coefficient
STD	Standard
SYM	Symbol; Symmetry (ical)
SYS	System
T	Ton
TAC	Toxic air contaminant
THK	Thick (ness)
TL	Total losses
TOG	Total organic gases
Topo	Topography
TP	Total phosphorous
tpd	Tons per day
tpy	Tons per year
TS	Tensile strength
TSP	Total suspended particulate matter
TSS	Total suspended solids
TVOC	Total volatile organic compounds, see VOCs
U, UR	Urinal
UFGS	Unified Facilities Guide Specifications
UH	Unit heater
UMCS	Utility Monitoring and Control System
USGS	United States Geological Survey
UST	Underground storage tank
UTIL	Utility
UV	Ultraviolet radiation
V	Volt (s)
VAR, VAV	Variable Air Volume: Ventilation system configuration differentiated from Constant Air Volume
VB	Vapor barrier
VENT	Ventilation; Ventilator
VMT	Vehicle miles traveled
VOC	Volatile organic compound

VOL	Volume
VP	Vent Pipe
W	Watt; Width; Wide; West; Wire
WB	Wet bulb; Wood base
WBDG	Whole Building Design Guide
WC	Water closet
WD	Wood
WH, DHWH	Water heater; Domestic hot water heater
WHO	World Health Organization
WP	Waterproof; Weatherproof
WPM	Waterproof membrane
WSTP	Wastewater sewage treatment plant
WW, WTW	Wall to wall
Y, yd	Yard
YR	Year
ZEV	Zero emissions vehicle (minimum energy star rating of 40)

GLOSSARY

Abatement Reducing the degree or intensity of or eliminating pollution.

Absorption The process by which incident light energy is converted to another form of energy, usually heat.

Absorption Rate The rate at which rentable space is filled. Absorption is equal to the amount occupied at the end of a period minus the amount occupied at the beginning of a period.

Access Aisle An accessible pedestrian space between elements, such as parking spaces, seating, and desks, which provides clearances appropriate for use of the elements.

Accessible Describes a site, building, facility, or portion thereof that complies with these guidelines.

Accessible Route A continuous unobstructed path connecting all accessible elements and spaces of a building or facility. Interior accessible routes may include corridors, floors, ramps, elevators, lifts, and clear floor space at fixtures. Exterior accessible routes may include parking access aisles, curb ramps, crosswalks at vehicular ways, walks, ramps, and lifts.

Acid Rain The precipitation of dilute solutions of strong mineral acids, formed of various industrial pollutants that mix in the earth's atmosphere. Sulfur dioxide and nitrogen oxides mix with naturally occurring oxygen and water vapor.

Acrylics A family of plastics used for fibers, rigid sheets, and paints.

Adaptability A design strategy that takes into account potentially different future functions in a space as need evolve and change. Adaptable design should be considered a sustainable/green building strategy because it minimizes the need to resort to major renovations or demolition of a structure to meet future needs.

Adapted Plants Plants that reliably grow well in a given habitat with minimal attention from humans in the form of winter protection, pest protection, water irrigation, or fertilization once root systems are established in the soil. Adapted plants are considered to be low maintenance but not invasive.

Addendum A written or graphic instruction issued by the architect prior to the execution of the contract which modifies or interprets the bidding documents by additions, deletions, clarifications, or corrections. An addendum becomes part of the contract documents when the contract is executed.

Adhesive Any substance that is used to bond one surface to another surface by attachment. Adhesives include adhesive bonding primers, adhesive primers, and any other primer.

Adobe A heavy clay soil used in many southwestern states to make sun-dried bricks.

Advances Payments made by the "special" servicer when the borrower fails to make a payment.

Advisor A person or organization who, pursuant to a contractual agreement, provides analysis of proposed investments, servicing of the real estate portfolio, and other advisory services.

Agency (1) Relationship between agent and principal. (2) Organization acting as agent. (3) Administrative subdivision of an organization, particular in government.

Agent One authorized by another to act in the other's stead or behalf.

- Agreement** (1) A meeting of minds. (2) A legally enforceable promise or promises between two or among several persons. (3) On a construction project, the document stating the essential terms of the Contract between Owner and Contractor which incorporates by reference the other Contract Documents. (4) The document setting forth the terms of the Contract between the Architect and Owner or between the Architect and a consultant. Agreement and **Contract** are often used interchangeably without any intended change in meaning.
- Aggregate** Fine, lightweight, coarse, or heavyweight grades of sand, vermiculite, perlite, or gravel added to cement for concrete or plaster.
- Air conditioning** A process that simultaneously controls the temperature, moisture content, distribution, and quality of air.
- Air filter** A device designed to remove contaminants and pollutants from air passing through the device.
- Air Handling Unit** A mechanical unit used for air conditioning or movement of air as in direct supply or exhaust of air within a structure.
- Air Pollution** The presence of contaminants or pollutant substances in the air that may be hazardous to human health or welfare or produce other harmful environmental effects.
- Aligned Section** A section view in which some internal features are revolved into or out of the plane of the view.
- Allergen** A substance capable of causing an allergic reaction because of an individual's sensitivity to that substance.
- Alternating Current (AC)** Electrical current that continually reverses direction of flow. The frequency at which it reverses is measured in cycles-per-second, or Hertz (Hz). The magnitude of the current itself is measured in amps (A).
- Alternative Energy** Environmentally sound energy that is not extensively used in the United States, such as solar or wind energy (as opposed to fossil fuels).
- Alternative Fuels** Transportation fuels other than gasoline or diesel, including natural gas, methanol, and electricity.
- Alternator** A device for producing Alternating Current ("AC") electricity. Usually driven by a motor but can also be driven by other means, including water and wind power.
- Ambient Lighting** Lighting in an area from any source that produces general illumination, as opposed to task lighting.
- Ambient Temperature** The temperature of the surroundings.
- American Bond** Brickwork pattern consisting of five courses of stretchers followed by one bonding course of headers.
- Ammeter** A device used for measuring current flow at any point in an electrical circuit.
- Amortizatio** The liquidation of a financial debt through regular periodic installment payments; for tax purposes, the periodic deduction of capitalized expenses such as organization costs.
- Ampere (A) or Amp** The unit for the electric current; the flow of electrons. One amp is 1 C passing in 1 s. One amp is produced by an electric force of 1V acting across a resistance of 1 ohm.
- Analog** The processing of data by continuously variable values.
- Anchor** The tenant that serves as the dominant draw to a commercial property. The largest tenant in a shopping center or mall.
- Anemometer** A device used to measure wind speed.
- Angle of Incidence** Angle between the normal to a surface and the direction of incident radiation; applies to the aperture plane of a solar panel. Only minor reductions in power output within plus/minus 15 degrees.

- Animal Dander** Tiny scales of animal skin.
- ANSI** The American National Standards Institute. ANSI is an umbrella organization that administers and coordinates the national voluntary consensus standards system. <http://www.ansi.org/>.
- Appeal** A formal written request to review the content of an exam question for accuracy, validity, or errors in content and grammar. Appeals must be specific to an exam question and must be submitted by the candidate to GBCI's Accreditation Department within 10 days of the exam appointment. The appeal must describe the content of the exam question and, if possible, the nature of error. Exam scores are not modified under any conditions.
- Appraisal** An estimate of a property's value (i.e., what the property would sell for if it was sold by a willing seller to a willing and fully informed buyer). This value is known in the industry the property's "fair market value."
- Appreciation** An increase in value or price of an asset.
- Approval** Written or imprinted acknowledgment that materials, equipment, or methods of construction are acceptable for use in the Work, or accepting a Contractor's or Owner's request or claim as valid.
- Approved Equal** Material, equipment, or method approved by the Architect for use in the work as being acceptable as an equivalent in essential attributes to the material, equipment, or method specified in the contract Documents.
- Arc** A portion of the circumference of a circle.
- Architect's Scale** The scale used when dimensions or measurements are to be expressed in feet and inches.
- Array** A number of solar modules connected together in a single structure.
- As-Built Drawings** Record drawings completed by the contractor and turned over to the owner at the completion of a project, identifying any change or adjustments made to the conditions and dimensions of the work relative to the original plans and specifications.
- Asphalt Shingles** They are shingles made of asphalt or tar-impregnated paper with a mineral material embedded; very fire resistant.
- Assumed Liability** It is a liability which arises from an agreement between people, as opposed to liability which arises from common or statutory law. See also Contractual Liability.
- ASTM International** Formerly the American Society for Testing Materials. They develop and publish testing standards for materials and specifications used by industry. <http://www.astm.org/>.
- Authority Having Jurisdiction (AHJ)** The governmental body responsible for the enforcement of any part of the Standard codes or the official or agency designated to exercise such a function and/or the Architect.
- Axial Load** A weight that is distributed symmetrically to a supporting member, such as a column.
- Axonometric Projection** A set of three or more views in which the object appears to be rotated at an angle, so that more than one side is seen.
- Backfill** Any deleterious material (sand, gravel, etc.) used to fill an excavation.
- Baffle** A single opaque or translucent element used to diffuse or shield a surface from direct or unwanted light.
- Ballasts** Electrical "starters" required by certain lamp types, especially fluorescents.
- Balloon Framing** A system in wood framing in which the studs are continuous without an intermediate plate for the support of second-floor joists.
- Balloon Loan** A loan with a maturity that is shorter than their He amortization period.

- Balloon Risk** The risk that a borrower will not be able i.e., make a balloon (lump sum) payment at maturity due to a lack of funding.
- Baluster** A vertical member that supports handrails or guardrails.
- Balustrades** A horizontal rail held up by a series of balusters.
- Banister** That part of the staircase which fits on top of the balusters.
- Bar Chart** A calendar that graphically illustrates a projected time allotment to achieve a specific function.
- Base** A trim or molding piece found at the interior intersection of the floor and the wall.
- Beam** A weight-supporting horizontal member.
- Base Building** The core (common areas) and shell of the building and its systems that typically are not subject to improvements to suit tenant requirements.
- Base Flashing** Consists of flashing that covers the edges of a membrane.
- Batten** A narrow strip of wood used to cover a joint.
- Batt Insulation** An insulating material formed into sheets or rolls with a foil or paper backing to be installed between framing members.
- Bearing Wall** A wall which supports any vertical loads in addition to its own weight.
- Benchmark** A point of known elevation from which the surveyors can establish all their grades.
- Bill Of Material** A list of standard parts or raw materials needed to fabricate an item.
- Bio-Based** Materials derived from natural renewable resources such as corn, rice, or beets.
- Biodegradable** Waste material composed primarily of naturally occurring elements that are able to be broken down and absorbed naturally into the ecosystem.
- Biodiversity** The tendency in ecosystems, when undisturbed to have a great variety of species forming a complex web of interactions. Human population pressure and resource consumption tend to reduce biodiversity dangerously; diverse communities are less subject to catastrophic disruption.
- Blackwater** Wastewater generated from toilet flushing. Blackwater has a higher nitrogen and fecal coliform level than gray water. Some jurisdictions include water from kitchen sinks or laundry facilities in the definition of blackwater.
- Blistering** The condition that paint presents when air or moisture is trapped underneath and makes bubbles that break into flaky particles and ragged edges.
- Blocking** The use of internal members to provide rigidity in floor and wall systems. Also used for fire draft stops.
- Blueprints** Documents containing all the instructions necessary to manufacture a part. The key sections of a blueprint are the drawing, dimensions, and notes. Although blueprints used to be blue, modern reproduction techniques now permit printing of black-on-white as well as colors.
- Board Foot** A unit of lumber of measure equaling 144 cubic inches; the base unit (B.F.) is 1 inch thick and 12 inches square or $1 \times 12 \times 12 = 144$ cubic inches.
- Boiler** Equipment designed to heat water or generate steam.
- Bond** In masonry, the interlocking system of brick or block to be installed.
- Boundary Survey** A mathematically closed diagram of the complete peripheral boundary of a site, reflecting dimensions, compass bearings, and angles. It should bear a licensed land surveyor's signed certification and may include metes and bounds or other written description.
- Breezeway** A covered walkway with open sides between two different parts of a structure.
- Brick Pavers** A term used to describe special brick to be used on the floor surface.
- British Thermal Unit (BTU)** The amount of heat energy required to raise one pound of water from a temperature of 60°F to 61°F at 1 atm pressure. One watt hour equals 3413 BTU.

- Building Codes** Prevailing regulations, ordinances, or statutory requirements set forth by governmental agencies associated with building construction practices and owner occupancy, adopted and administered for the protection of public health, life safety, and welfare. Building codes are interpreted to include structural, HVAC, plumbing, electrical, life safety, and vertical transportation codes.
- Building Density** The total floor area of a building divided by the total area of the site (square feet per acre).
- Building Envelope** The enclosure of the building that protects the building's interior from outside elements, namely the exterior walls, roof, and soffit areas.
- Building Inspector** A representative of a governmental authority employed to inspect construction for compliance codes, regulations, and ordinances.
- Building Line** An imaginary line determined by zoning departments to specify on which area of a lot a structure may be built (also known as a setback).
- Building Permit** A permit issued by appropriate governmental authority allowing construction of a project in accordance with approved Drawing and Specifications.
- Building-Related Illness** A diagnosable disease or illness that can be traced to a specific pollutant or source within a building (contrast with "Sick building syndrome").
- Building Systems** Interacting or independent components or assemblies, which form single integrated units, that comprise a building and its site work, such as, pavement and flatwork, structural frame, roofing, exterior walls, plumbing, HVAC, electrical, etc.
- Build-Out** The interior construction and customization of a space (including services, space, and stuff) to meet the tenant's requirements; either new construction or renovation (also referred to as fit-out or fit-up).
- Build to Suit** A property built to a tenant's specifications.
- By-Product** Materials other than the intended product, generated as a result of an industrial process.
- Caisson** A below-grade concrete column for the support of beams or columns.
- Callback** A request by a project owner to the contractor to return to the job site to correct or redo some item of work.
- Candela** A common unit of light output from a source.
- Cantilever** A horizontal structural condition where a member extends beyond a support, such as a roof overhang.
- Capillary** The action by which the surface of a liquid, where it is in contact with a solid, is elevated or depressed.
- Capital Gain** The amount by which the net proceeds from resale of a capital item exceed the book value of the asset.
- Capital Markets** Public and/or private markets where businesses or individuals can raise or borrow capital.
- Capitalization Rate** The rate at which net operating income is discounted at to determine the value of a property. It is one method that is utilized to estimate property value. When two of three values are known (annual net operating income, cap rate, property value estimate) the calculations are as follows: $\text{Value} = \text{NOI} / \text{Cap Rate}$; $\text{NOI} = \text{Value} \times \text{Cap Rate}$; $\text{Cap Rate} = \text{NOI} / \text{Value}$.
- Carbon Footprint** A measure of an individual's, family's, community's, company's, industry's, product's, or service's overall contribution of carbon dioxide and other greenhouse gases into the atmosphere. It takes into account energy use, transportation methods, and other means of emitting carbon. A number of carbon calculators have been created to estimate carbon footprints, including one from the U.S. Environmental Protection Agency.

- Carbon Sinks** Carbon reservoirs and conditions that take in and store more carbon (carbon sequestration) than they release. Carbon sinks can serve to partially offset greenhouse gas emissions. Forests and oceans are common carbon sinks.
- Carcinogens** Substances that cause cancer in humans.
- Casement** A type of window hinged to swing outward.
- Cash Flow** The revenue remaining after all cash expenses are paid; non cash charges such as depreciation are not included in the calculation. See Net Cash Flow.
- Catch Basin** A complete drain box made in various depths and sizes; water drains into a pit, then from it through a pipe connected to the box.
- Caulk** Any type of material used to seal walls, windows, and doors to keep out the weather.
- Cavity Wall** A masonry wall formed with an air space between each exterior face.
- Cement Plaster** A plaster that is comprised of cement rather than gypsum.
- Central HVAC System** A system that produces a heating or cooling effect in a central location for subsequent distribution to satellite spaces that require conditioning; see also All-Air, All-Water, and Air-Water HVAC Systems.
- Centrifugal** A particular type of fluid-moving device that imparts energy to the fluid by high-velocity rotary motion through a channel; fluids enter the device along one axis and exit along another axis.
- Certificate for Payment** A statement from the Architect to the Owner confirming the amount of money due the contractor for Work accomplished or materials and equipment suitably stored, or both.
- Certificate of Insurance** A document issued by an authorized representative of an insurance company stating the types, amounts, and effective dates of insurance in force for a designated insured.
- Certificate of Occupancy** Document issued by governmental authority certifying that all or a designated portion of a building complies with the provisions of applicable statutes and regulations and permitting occupancy for its designated use.
- Certificate of Substantial Completion** A certificate prepared by the Architect on the basis of an inspection stating that the Work or a designated portion thereof is substantially complete, which established the Date of Substantial Completion; states the responsibilities of the Owner and the Contractor for security, maintenance, heat, utilities, damage to the Work, and insurance; and taxes the time within which the Contractor shall complete the items listed therein.
- Certified Wood** Wood-based materials used in building construction that are supplied from sources that comply with sustainable forestry practices, protecting trees, wildlife habitat, streams, and soil as determined by the Forest Stewardship Council or other recognized certifiable organizations.
- Cesspool** An underground catch basin for the collection and dispersal of sewage.
- Chain of Custody** A document that tracks the movement of a product from the point of harvest or extraction to the end user.
- Change Order** A written and signed document between the owner and the contractor authorizing a change in the work to be executed or an adjustment in the contract sum or time. The contract sum and time may be modified only by change order. A change order may be in the form of additional compensation or time; or less compensation or time known as a "Deduction."
- Checklist** List of items used to check drawings.
- Chiller** Equipment designed to produce chilled water; see also Vapor Compression Chiller (Centrifugal, Reciprocating) and Absorption Chiller.

- Circuit** A continuous system of conductors providing a path for electricity.
- Circuit breaker** A circuit breaker acts like an automatic switch that can shut the power off when it senses too much current.
- Circumference** The length of a line that forms a circle.
- Class A** A real estate rating which generally is assigned to those properties in a market that will generate the highest rents per square foot due to their high quality and/or superior location.
- Class B** Good assets that most tenants would find desirable, but buildings lack attributes that would permit owners to charge top dollar.
- Class C** Buildings that offer few amenities but are otherwise in physically acceptable condition and provide cost-effective space to tenants who are not particularly image conscious.
- Clear Floor Space** The minimum unobstructed floor or ground space required to accommodate a single, stationary wheelchair and occupant.
- Clerestory** A window or group of windows that are placed above the normal window height, often between two roof levels.
- Coefficient of Utilization (CU)** The ratio of light energy (lumens) from a source, calculated as received on the workplane, to the light energy emitted by the source alone.
- Collateral** Asset(s) pledged to the lender to secure repayment of the loan in case of default.
- Column** A vertical weight-supporting member.
- Combustion** An oxidation process that releases heat; on-site combustion is a common heat source for buildings.
- Commissioning (Cx)** A systematic process to verify that building components and systems function as intended and required; systems may need to be recommissioned at intervals during a building's life cycle.
- Common Use** Refers to those interior and exterior rooms, spaces, or elements that are made available for the use of a restricted group of people (for example, occupants of a homeless shelter, the occupants of an office building, or the guests of such occupants).
- Component** A fully functional portion of a building system, piece of equipment, or building element.
- Composite Wood** A product consisting of wood or plant particles or fibers bonded together by a synthetic resin or binder. Examples include plywood, particle-board, OSB, MDF, composite door cores.
- Composting Toilet** A dry plumbing fixture that contains and treats human waste via a microbiological process.
- Compressor** A device designed to compress (increase the density) of a compressible fluid; a component used to compress refrigerant; a component used to compress air.
- Computer-Aided Drafting (CAD)** A method by which engineering drawings may be developed on a computer.
- Computer-Aided Manufacturing (CAM)** A method by which a computer uses a design to guide a machine that produces parts.
- Concrete Block** A rectangular concrete form with cells in them.
- Condensation** The process by which moisture in the air becomes water or ice on a surface (such as a window) whose temperature is colder than the air's temperature.
- Condenser** A device designed to condense a refrigerant; an air-to-refrigerant or water-to-refrigerant heat exchanger; part of a vapor compression or absorption refrigeration cycle.
- Conductor** A material used to transfer, or conduct, electricity, often in the form of wires.

- Conduit** (1) A pipe or elongated box used to house and protect electrical cables; (2) an alliance between mortgage originators and an unaffiliated organization that agrees, in advance, to act as a funding source by regularly purchasing the loans, normally with a view toward pooling and securitizing them.
- Conservation** Act of preserving and renewing when possible, human and natural resources and the use, protection, and improvement of natural resources according to recognized principles that ensure their highest economic or social benefits.
- Construction Documents** A term used to represent all drawings, specifications, addenda, and other pertinent construction information associated with the construction of a specific project.
- Construction Loan** Interim financing during the developmental phase of a property.
- Contamination** Intrusion of undesirable elements. The addition of foreign matter to a substance that reduces the value of the substance or interferes with its intended use.
- Contingency Allowance** A sum included in the Project budget designated to cover unpredictable or unforeseen items of Work, or changes in the Work subsequently required by the Owner. See Budget, Project.
- Contour Line** A line that represents the change in level from a given datum point.
- Contract** A legally enforceable promise or agreement between two or among several persons. See also Agreement.
- Convection** Transfer of heat through the movement of a liquid or gas.
- Cooling tower** Equipment designed to reject heat from a refrigeration cycle to the outside environment through an open cycle evaporative process; an exterior heat rejection unit in a water-cooled refrigeration system.
- Core Properties** The major property types, specifically office, retail, industrial, and multifamily.
- Cornice** The projecting or overhanging structural section of a roof.
- Corrosion** Dissolution and wearing away of metal caused by a chemical reaction such as between water and the pipes or chemicals touching a metal surface.
- Cost Appraisal** Evaluation or estimate (preferably by a qualified professional appraiser) of the market or other value, cost, utility, or other attribute of land or other facility.
- Cost Estimate** A preliminary statement of approximate cost, determined by one of the following methods. (1) Area and volume method; cost per square foot or cubic foot of the building. (2) Unit cost method; cost of one unit multiplied by the number of units in the project; for example, in a hospital, the cost of one patient unit multiplied by the number of patient units in the project. (3) In-place unit method; cost in-place of a unit, such as doors, cubic yards of concrete, and squares of roofing.
- Coving** The curving of the floor material against the wall to eliminate the open seam between floor and wall.
- Cradle-To-Grave Analysis** Analysis of the impact of a product from the beginning of its source gathering processes, through the end of its useful life, to disposal of all waste products. Cradle-to-cradle is a related term signifying the recycling or reuse of materials at the end of their first useful life.
- Crawl Space** The area under a floor that is not fully excavated; only excavated sufficiently to allow one to crawl under it to get at the electrical or plumbing devices.
- Critical Path** A schedule of tasks or sequences developed by the contractor after carefully considering dependencies between construction tasks to ensure there are no delays on "critical" elements that would delay subsequent tasks and thereby delay completion of the project. The sequence of tasks, which have no tolerance for delay, constitutes the critical path.

- Cross collateralization** A grouping of mortgages or properties that serves to jointly secure one debt obligation. Any deficiency in income or loss on the sale of one property can be made up by the income or sale of another property.
- Cross defaulting** This feature allows the trustee to call all loans in a group into default when any single loan is in default.
- Cross section** A slice through a portion of a building or member that depicts the various internal conditions of that area.
- CSI** Construction Specifications Institute. Membership organization of design professionals, construction professionals, product manufacturers, and building owners. Develops and promotes industry communication standards and certification programs. <http://www.csinet.org/>.
- Current** It is the flow of electric charge in a conductor between two points having a difference in electrical potential (voltage) and is measured in amps.
- Curtain Wall** An exterior wall that provides no structural support.
- Cutoff Voltage** The voltage levels at which the charge controller (regulator) disconnects the PV array from the battery or the load from the battery.
- Damper** A device designed to regulate the flow of air in a distribution system.
- Dangerous or Adverse Conditions** These are essentially conditions which may pose a threat or possible injury to the field observer, and which may require the use of special protective clothing, safety equipment, access equipment, or any other precautionary measures.
- Date of Agreement** The date stated in the Agreement. If no date is stated, it could be the date on which the Agreement is actually signed, if this is recorded, or it may be the date established by the award.
- Date of Commencement of the Work** The date established in a notice to the Contractor to proceed or, in the absence of such notice, the date of the Owner contractor Agreement or such other date and may be established therein.
- Date of Substantial Completion** The Date certified by the Architect when the Work or a designated portion thereof is sufficiently complete, in accordance with the Contract Documents, so the Owner can occupy the Work or designated portion thereof for use for which it is intended.
- Datum Point** Reference point.
- Daylight Factor (DF)** The ratio of daylight illumination at a given point on a given plane, from an obstructed sky of assumed or known illuminance distribution, to the light received on a horizontal plane from an unobstructed hemisphere of this sky, expressed as a percentage. Direct sunlight is excluded for both values of illumination. The daylight factor is the sum of the sky component, the external reflected component, and the internal reflected component. The interior plane is usually a horizontal workplane. If the sky condition is the CIE standard overcast condition, then the DF will remain constant regardless of absolute exterior illuminance.
- Daylighting** The controlled admission of natural light into a space through glazing with the intent of reducing or eliminating electric lighting. By utilizing solar light, daylighting creates a stimulating and productive environment for building occupants.
- Dead Load** The weight of a structure and all its fixed components.
- Deal Structure** With regard to the financing of an acquisition, deals can be unleveraged, leveraged, traditional debt, participating debt, participating/convertible debt, or joint ventures.
- Decibel (dB)** Unit of sound level or sound-pressure level. It is 10 times the logarithm of the square of the sound pressure divided by the square of reference pressure, 20 μ Pa.

- Deconstruction** The process of taking apart a structure with the primary goal of preserving the value of all useful building materials, so that they may be reused or recycled.
- Defective Work** The work not conforming with the contract requirements.
- Deferred Maintenance** Physical deficiencies that cannot be remedied with routine maintenance, normal operating maintenance, etc., excluding de minimis conditions that generally do not present a material physical deficiency to the subject property.
- Depreciation** A decrease or loss in property value due to wear, age, or other cause. In accounting, depreciation is a periodic allowance made for this real or implied loss.
- Design-Build Construction** When an owner contracts with a prime or main contractor to provide both design and construction services for the entire construction project. Use of the design-build project delivery system has grown from 5% of US construction in 1985–33% in 1999 and is projected to surpass low-bid construction in 2005. If a design-build contract is extended further to include the selection, procurement, and installation of all furnishings, furniture, and equipment, it is called a “turnkey” contract.
- Details** An enlarged drawing to show a structural aspect, an aesthetic consideration, a solution to an environmental condition or to express the relationship among materials or building components.
- Debt-to-Capital Ratio** A measurement of a company’s financial leverage, calculated as long-term debt divided by long-term capital. Total debt includes all short-term and long-term obligations. Total capital includes all common stock, preferred stock, and long-term debt. This capital structure ratio can provide a more accurate view of a company’s long-term leverage and risk, since it considers long-term debt and capital only. By excluding short-term financing in its calculation, the ratio provides an investor with a more accurate look into the capital structure a company will have if they were to own the stock over a long period of time.
- Diffuser** A device designed to supply air to a space while providing good mixing of supply and room air and avoiding drafts; normally ceiling installed.
- Digital** The processing of data by numerical or discrete units.
- Dimension Line** A thin unbroken line (except in the case of structural drafting) with each end terminating with an arrowhead; used to define the dimensions of an object. Dimensions are placed above the line, except in structural drawing where the line is broken and the dimension placed in the break.
- Direct Costs (Hard Costs)** The aggregate costs of all labor, materials, equipment, and fixtures necessary for the completion of construction of the Improvements.
- Direct Costs Loan; Indirect Costs Loan** The portion of the Loan amount applicable and equal to the sum of the Loan Budget Amounts for Direct Costs and Indirect Costs, respectively, shown on the Borrower’s Project Cost Statement.
- Direct Current (DC)** Electrical current that flows only in one direction, although it may vary in magnitude. Contrasts with alternating current.
- Discount Factor** The factor that translates expected benefits or costs in any given future year into present value terms. The discount factor is equal to $1/(1+i)^t$ where i is the interest rate and t is the number of years from the date of initiation for the program or policy until the given future year.
- Discount Rate** The interest rate used in calculating the present value of expected yearly benefits and costs.
- Discretionary Funds** A fully discretionary account typically is defined as one in which the advisor or manager has a client’s consent and approval to invest and manage the client’s capital as deemed appropriate and prudent by the advisor.

- Disinfectant** A chemical or physical process that kills pathogenic organisms in water, air, or on surfaces. Chlorine is often used to disinfect sewage treatment, water supplies, wells, and swimming pools.
- Diversification** In a real estate portfolio, the inclusion of divergent property types and property geographic locations so as to minimize the impact on performance of fluctuations in a single market.
- Dormer** A structure that projects from a sloping roof to form another roofed area. This new area is typically used to provide a surface to install a window.
- Downcycling** Recycling a material in a manner that much of its inherent value is lost.
- Downspouts** Pipes connected to the gutter to conduct rainwater to the ground or sewer.
- Drip Irrigation System** An irrigation system that slowly applies water to the root system of plants to maximize transpiration while minimizing wasted water and topsoil runoff. Drip irrigation usually involves a network of pipes and valves that rest on the soil or underground at the root zone.
- Drywall** An interior wall covering installed in large sheets made from gypsum board.
- Duct** Usually sheet metal forms used for the distribution of cool or warm air throughout a structure.
- Due Diligence** The process of conducting a walk through survey and appropriate inquiries into the physical condition of a commercial real estate's improvements, usually in connection with a commercial real estate transaction. The degree and type of such survey or other inquiry may vary for different properties and different purposes.
- Dwelling Unit** A single unit which provides a kitchen or food preparation area, in addition to rooms and spaces for living, bathing, sleeping, and the like. Dwelling units include a single family home or a townhouse used as a transient group home; an apartment building used as a shelter; guestrooms in a hotel that provide sleeping accommodations and food preparation areas; and other similar facilities used on a transient basis. For purposes of these guidelines, use of the term "Dwelling Unit" does not imply the unit is used as a residence.
- Easement** The right or privilege to have access to or through another piece of property such as a utility easement.
- Eave** The portion of the roof that extends beyond the outside wall.
- Ecological/Environmental Sustainability** Maintenance of ecosystem components and functions for future generations.
- Ecological Impact** The impact that a human-caused or natural activity has on living organisms and their nonliving environment.
- Ecosystem** The interacting system of a biological community and its nonliving environmental surroundings. An ecological community together with its environment, functioning as a unit.
- Egress** A continuous and unobstructed way of exit travel from any point in a building or facility to a public way. A means of egress comprises vertical and horizontal travel and may include intervening room spaces, doorways, hallways, corridors, passageways, balconies, ramps, stairs, enclosures, lobbies, horizontal exits, courts, and yards. An accessible means of egress is one that complies with these guidelines and does not include stairs, steps, or escalators. Areas of rescue assistance or evacuation elevators may be included as part of accessible means of egress.
- Electric Current** The flow of electrons measured in amps.
- Electrical Grid** A network for electricity distribution across a large area.
- Electricity** The movement of electrons (a subatomic particle), produced by a voltage, through a conductor.

- Electrode** An electrically conductive material, forming part of an electrical device, often used to lead current into or out of a liquid or gas. In a battery, the electrodes are also known as plates.
- Element** An architectural or mechanical component of a building, facility, space, or site, e.g., telephone, curb ramp, door, drinking fountain, seating, or water closet.
- Embodied Energy** The total energy that a product may be said to “contain,” including all energy used in growing, extracting, and manufacturing it and the energy used to transport it to the point of use. The embodied energy of a structure or system includes the embodied energy of its components plus the energy used in construction.
- Emission** The release or discharge of a substance into the environment. Generally refers to the release of gases or particulates into the air.
- Energy** Power consumed multiplied by the duration of use. For example, 1000W used for 4 h is 4000Wh.
- Energy Conservation** Thoughtful and frugal management of energy. The result of such deliberate and planned conservation results in saving energy for future use.
- Energy Efficiency** Reducing the amount of electricity and/or fuel to do the same work, typically without changing the quality of the services provided. Efficiency can be accomplished by utilizing high-efficiency appliances, better insulation, better building design, and mechanical improvements.
- Energy Star Rating** A designation given by the EPA and the U.S. Department of Energy (DOE) to appliances and products that exceed federal energy efficiency standards. The label helps consumers identify products that are energy efficient and will save money.
- Engineer’s Scale** The scale used whenever dimensions are in feet and decimal parts of a foot, or when the scale ratio is a multiple of 10.
- Environmental Tobacco Smoke (ETS)** Mixture of smoke from the burning end of a cigarette, pipe, or cigar and smoke exhaled by the smoker (also secondhand smoke or passive smoking). See Smoke-Free Homes Program at www.epa.gov/smokefree.
- Environmentally Friendly** A term often used to refer to the degree to which a product may harm the environment including the biosphere, soil, water, and air.
- Epicenter** The point of the earth’s surface directly above the focus or hypocenter of an earthquake.
- Equity** The residual value of a property beyond mortgage or liability. A 100% equity acquisition is an all cash deal.
- Exit Strategy** Strategy available to investors when they desire to liquidate all or part of their investment.
- Expansion Joint** A joint often installed in concrete construction to reduce cracking and to provide workable areas.
- Expected Useful Life (EUL)** The average amount of time in years that an item, component, or system is estimated to function when installed new and assuming routine maintenance is practiced.
- Exploded View** A pictorial view of a device in a state of disassembly, showing the appearance and interrelationship of parts.
- Extension Line** A line used to visually connect the ends of a dimension line to the relevant feature on the part. Extension lines are solid and are drawn perpendicular to the dimension line.
- Facade** The exterior covering of a structure.
- Face of Stud (F.O.S.)** Outside surface of the stud. Term used most often in dimensioning or as a point of reference.
- Fascia** A horizontal member located at the edge of a roof overhang.

- Facility** All or any portion of buildings, structures, site improvements, complexes, equipment, roads, walks, passageways, parking lots, or other real or personal property located on a site.
- Felt** A tar-impregnated paper used for water protection under roofing and siding materials; sometimes used under concrete slabs for moisture resistance.
- Fiber Optics** Optical, clear strands that transmit light without electrical current; sometimes used for outdoor lighting.
- Fiduciary** A person or firm that holds something in trust for another. ERISA defines a fiduciary as any person who: (1) exercises any discretionary authority or control over a plan's management or disposition of its assets; (2) renders investment advice for a fee or other compensation with respect to plan assets; (3) has any discretionary authority or responsibility in a plan's administration.
- Fillet** A concave internal corner in a metal component, usually a casting.
- Filter** A device designed to remove impurities from a fluid passing through the device; see also Air Filter.
- Final Completion** Term denoting that the work has been completed in accordance with the terms and conditions of the contract documents.
- Final Inspection** Final review of the project by the architect to determine final completion, prior to issuance of the final certificate for payment.
- Final Payment** The payment made by the owner to the contractor upon issuance by the architect of the final certificate for payment of the entire unpaid balance of the contract sum as adjusted by change orders.
- Finish Grade** The soil elevation in its final state upon completion of construction.
- Fire Barrier** A continuous membrane such as a wall, ceiling, or floor assembly that is designed and constructed to a specified fire-resistant rating to hinder the spread of fire and smoke. This resistant rating is based on a time factor. Only fire-rated doors may be used in these barriers.
- Fire Compartment of Fire Zone** An enclosed space in a building that is separated from all other parts of the building by the construction of fire separations having fire resistance ratings.
- Fire Door** A door used between different types of construction that has been rated as being able to withstand fire for a certain amount of time.
- Fire Resistance Rating** Sometimes called fire rating, fire resistance classification, or hourly rating. A term defined in building codes, usually based on fire endurance required. Fire resistance ratings are assigned by building codes for various types of construction and occupancies and are usually given in half hour increments.
- Fire-Stop** Blocking placed between studs or other structural members to resist the spread of fire.
- Firewall** A type of fire separation of noncombustible construction which subdivides a building or separates adjoining buildings to resist the spread of fire and which has a fire-resistance rating as prescribed in the NBC and has structural ability to remain intact under fire conditions for the required fire-rated time.
- Fixed Rate** A loan interest rate (coupon) that remains constant over the term of the loan.
- Flashing** A thin, impervious sheet of material placed in construction to prevent water penetration or to direct the flow of water. Flashing is used especially at roof hips and valleys, roof penetrations, joints between a roof and a vertical wall, and in masonry walls to direct the flow of water and moisture.
- Floodplain** Mostly level land along rivers and streams that may be submerged by floodwater. A 100-year floodplain is an area that can be flooded once in every 100 years.

- Floor Joist** Structural member for the support of floor loads.
- Floor Plan** A horizontal section taken at approximately eye level.
- Flush** Even, level, or aligned.
- Flush-Out** The operation of mechanical systems for a minimum of 2 weeks using 100% outside air upon completion of construction and prior to building occupancy to ensure safe indoor air quality.
- Fly Ash** The fine ash waste collected from the flue gases of coal combustion, smelting, or waste incineration.
- Footcandle** A common unit of illuminance used in the United States. The metric unit is the lux.
- Footings** Weight-bearing concrete construction elements poured in place in the earth to support a structure.
- Footlambert** The US unit for luminance. The metric unit is the nit.
- Foreclosure** A legal proceeding by which a mortgage lender may claim title to a mortgaged property if a borrower fails to repay the loan.
- Formaldehyde** A colorless, pungent, and irritating gas mainly used as a disinfectant and preservative and in synthesizing other compounds such as resins.
- Fossil Fuels** Fuel derived from ancient organic remains such as peat, coal, crude oil, and natural gas.
- Foundation Plan** A drawing that graphically illustrates the location of various foundation members and conditions that are required for the support of a specific structure.
- Frieze** A decoration or ornament shaped to form a band around a structure.
- Frost Line** The depth at which frost penetrates the soil.
- Fungi** Any of a group of parasitic lower plants that lack chlorophyll, including molds and mildews.
- Fuse** A fuse is a device used to protect electrical equipment from short circuits. Fuses are made with metals that are designed to melt, when the current passing through them is high enough. When the fuse melts, the electrical connection is broken, interrupting power to the circuit or device.
- Galvanized** Steel products that have had zinc applied to the exterior surface to provide protection from rusting.
- Gauge** The thickness of metal or glass sheet material.
- General Conditions** (When used by contractors) Construction project activities and their associated costs that are not usually assignable to a specific material installation or sub-contract, e.g., temporary electrical power. (When used by everyone else) The contract document (often a standard form) that spells out the relationships between the parties to the contract, e.g., the AIA Document A201.
- General Contract** Any contract (together with all riders, addenda, and other instruments referred to therein as “contractor or any other person, which requires the General Contractor or such other person to provide, or supervise or manage the procurement of, substantially all labor and material needed for completion of the Improvements.
- Generator** A mechanical device used to produce DC electricity. Power is produced by coils of wire passing through magnetic fields inside the generator. Most alternating current generating sets are also referred to as generators.
- Geothermal** Literally, heat from the earth; energy obtained from the hot areas under the surface of the earth. Examples are geysers, molten rocks, and steam spouts.
- Gigawatt (GW)** A measurement of power equal to a 1000 million watts.
- Gigawatt-Hour (GWh)** A measurement of energy. One gigawatt-hour is equal to 1 GW being used for a period of 1 h, or 1 MW being used for 1000 h.

- Girder** A horizontal structural beam for the support of secondary members such as floor joists.
- Glare** The effect produced by luminance within one's field of vision that is sufficiently greater than the luminance to which one's eyes are adapted; it can cause annoyance, discomfort, or loss in visual performance and visibility.
- Global Warming** An increase in the average temperature of the earth's surface. This increase in temperature usually precedes an increase in greenhouse gases, sometimes called the greenhouse effect. These gases are released from burning gas, oil, coal, and wood.
- Grading** The moving of soil to effect the elevation of land at a construction site.
- Gray water** Wastewater that does not contain toilet wastes and can be reused for irrigation after simple filtration. Wastewater from kitchen sinks and dishwashers may not be considered gray water in all cases.
- Green Building** A building using energy, water, materials, and land in a much more efficient manner than are buildings which are built to code. Such environments are healthier for the people living and working in them. Such sustainable buildings are cost effective and actually require fewer dollars for operation and maintenance.
- Green Design** A design, usually architectural, conforming to environmentally sound principles of building, material, and energy use. A green building, for example, might make use of solar panels, skylights, and recycled building materials.
- Green Energy** A popular term for energy produced from renewable energy resources or, sometimes, from clean (low-emitting) energy sources.
- Greenfields** Land not previously developed beyond agriculture or forestry use.
- Greenhouse Gas** A gas in the atmosphere that traps some of the sun's heat and preventing it from escaping into space. Greenhouse gases are vital for making the Earth habitable, but increasing greenhouse gases contribute to climate change. Greenhouse gases include water vapor, carbon dioxide, methane, nitrous oxide, and ozone.
- Greenhouse Effect** The process that raises the temperature of air in the lower atmosphere due to heat trapped by greenhouse gases, such as carbon dioxide, methane, nitrous oxide, chlorofluorocarbons, and ozone.
- Green Power** Electricity generated from renewable energy sources.
- Greenwash** Disinformation disseminated by an organization so as to present an environmentally responsible public image.
- Grid** An electrical utility distribution network.
- Grid-Connected** An energy producing system connected to the utility transmission grid; also called Grid tied.
- Ground Water** Fresh water found beneath the Earth's surface, usually in aquifers, which supplies wells and springs. Ground water is a major source of drinking water.
- Grout** A mixture of cement, sand, and water used to fill joints in masonry and tile construction.
- Guardrail** A horizontal protective railing used around stairwells, balconies, and changes of floor elevation greater than 30 in.
- Halogen Lamp** A special type of incandescent globe made of quartz glass and a tungsten filament, enabling it to run at a much higher temperature than a conventional incandescent globe. Efficiency is better than a normal incandescent but not as good as a fluorescent light.
- Harmonic Content** Frequencies in the output waveform in addition to the primary frequency (usually 50 or 60 Hz). Energy in these harmonics is lost and can cause undue heating of the load.
- Harvested Rainwater** Captured rainwater used for indoor needs, irrigation, or both.

- Hazardous Waste** By-products of society that can pose a substantial or potential hazard to human health or the environment when improperly managed. Possesses at least one of four characteristics—ignitable, corrosive, reactive, or toxic, or appears on special EPA lists.
- Head** The top of a window or door frame.
- Header** A horizontal structural member spanning over openings, such as doors and windows, for the support of weight above the openings.
- Header Course** In masonry, a horizontal masonry course of brick laid perpendicular to the wall face; used to tie a double wythe brick wall together.
- Heat Exchanger** A device designed to efficiently transfer heat from one medium to another (for example, water-to-air, refrigerant-to-air, refrigerant-to-water, steam-to-water).
- Heat Island Effect** The incidence of higher air and surface temperatures caused by solar absorption and reemission from roads, buildings, and other structures.
- Heat Pump** A device that uses a reversible cycle vapor compression refrigeration circuit to provide cooling and heating from the same unit (at different times).
- Heat Recovery** A process whereby heat is extracted from exhaust air before the air is dumped to the outside environment, and the recovered heat is normally used to preheat incoming outside air; may be accomplished by heat recovery wheels or heat exchanger loops.
- Hertz (Hz)** Unit of measurement for frequency. Home mains power is normally 50Hz in Europe and 60Hz in the United States. The magnitude of the current is measured in amps.
- High-Performance Green Building** Buildings that create healthy indoor environments and include design features that conserve water and energy; efficient use of space, materials, and resources; and minimize construction waste.
- Hydronic System** A heating or cooling system that relies on the circulation of water as the heat-transfer medium. A typical example is a boiler with hot water circulated through radiators.
- Illuminance** The density of the luminous flux incident on a surface, expressed in foot-candles or lux. This term should not be confused with illumination (i.e., the act of illuminating or state of being illuminated).
- Impervious Surfaces** Surfaces that promote runoff of precipitation volumes instead of infiltration into the subsurface.
- Incandescent Light** An electric lamp which is evacuated or filled with an inert gas and contains a filament (commonly tungsten). The filament emits visible light when heated to extreme temperatures by passage of electric current through it.
- Incident Light** Light that shines on to the surface of a PV cell or module.
- Income Property** Real estate owned or operated to produce revenue.
- Indemnification** A contractual obligation by which one person or entity agrees to secure another against loss or damage from specified liabilities. See also Contractual Liability.
- Indirect Cost Statement** A statement by the Borrower in a form approved by the Lender of Indirect Costs incurred and to be incurred.
- Indoor Air Pollution** Chemical, physical, or biological contaminants contained in indoor air.
- Indoor Air Quality (IAQ)** According to the U.S. Environmental Protection Agency and National Institute of Occupational Safety and Health, the definition of good IAQ includes: (1) introduction and distribution of adequate ventilation air; (2) control of airborne contaminants; and (3) maintenance of acceptable temperature and relative humidity. According to ASHRAE Standard 62 1989, IAQ is defined as “air in which there are no known contaminants at harmful concentrations as determined by cognizant authorities and with which a substantial majority (80% or more) of the people exposed do not express dissatisfaction.”

- Indoor Environmental Quality (IEQ)** The evaluation of five primary elements—lighting, sound, thermal conditions, air pollutants, and surface pollutants, to provide an environment that is physically and psychologically healthy for its occupants.
- Industrial Waste** Unwanted materials produced in or eliminated from an industrial operation and categorized under a variety of headings, such as liquid wastes, sludge, solid wastes, and hazardous wastes.
- Infill Site** A site that is largely located within an existing community. For the purposes of LEED for Homes credits, an infill site is defined as having at least 75% of its perimeter bordering land that has been previously developed.
- Inscribed Figure** A figure that is completely enclosed by another figure.
- Insolation** The amount of sunlight reaching an area, usually expressed in watt hours per square meter per day.
- Inspection** Examination of Work completed or in progress to determine its conformance with the requirements of the Contract Documents. The Architect ordinarily makes only two inspections of Work, one to determine Substantial Completion and the other to determine final completion. These inspections should be distinguished from the more general observations made by the Architect on visits to the site during the progress of the Work. The term is also used to mean examination of the Work by a public official, Owner's representative, or others.
- Insulation** Any material capable of resisting thermal, sound, or electrical transmission.
- Integrated Design Team** The team of all individuals involved in a project from very early in the design process, including the design professionals, the owner's representatives, and the general contractor and subcontractors.
- Internal Rate of Return** The discount rate that sets the net present value of the stream of net benefits equal to zero. The internal rate of return may have multiple values when the stream of net benefits alternates from negative to positive more than once.
- Inverter** An inverter converts DC power from the PV array/battery to AC power. Used either for stand-alone systems or grid-connected systems.
- Irradiance** The solar power incident on a surface, usually expressed in kilowatts per square meter. Irradiance multiplied by time gives insolation.
- Isometric Drawing** A form of a pictorial drawing in which the main lines are equal in dimension; normally drawn using 30- and 90-degree angle.
- Jamb** The side portion of a door, window, or any opening.
- Joint Venture** An investment structure where two or more persons or corporate entities contract together to carry out a specific business transaction.
- Joist** A horizontal beam used to support a ceiling.
- Joule (J)** The energy conveyed by 1W of power for 1 s, unit of energy equal to 1/3600 kWh.
- Junction box** A PV junction box is a protective enclosure on a PV module where PV strings are electrically connected and where electrical protection devices such as diodes can be fitted.
- Key Plan** A plan, reduced in scale, used for orientation purposes.
- Kilowatt (kW)** A unit of electrical power, 1000W.
- Kilowatt-hour (kWh)** The amount of energy that derives from a power of 1000W acting over a period of 1 h. The kWh is a unit of energy. 1 kWh = 3600 kJ.
- Landfill** A cavity in the ground where nonhazardous waste is piled up and eventually covered with dirt and topsoil. Today's landfills are deemed sanitary and require special technology to eliminate methane gas.
- Lattice** A grille made by crisscrossing strips of material.
- Ledger** Structural framing member used to support ceiling and roof joists at the perimeter walls.

- LEED** Leadership in Energy and Environmental Design. A sustainable design building certification system promulgated by the United States Green Building Council; also an accrediting program for professionals (LEED APs) who have mastered the certification system. <http://www.usgbc.org/>.
- LEED Accredited Professional (LEED AP)** The credential earned by candidates who passed the exam between 2001 and June 2009.
- Legend** A description of any special or unusual marks, symbols, or line connections used in the drawing.
- Leverage** The use of credit to finance a portion of the costs of purchasing or developing a real estate investment. Positive leverage occurs when the loan constant (interest rate) is lower than the capitalization rate (or lower than the projected IRR).
- Liability Insurance** Insurance which protects the insured against liability on account of injury to the person or property or another. (1) Completed Operations Insurance; (2) Comprehensive General Liability Insurance; (3) Contractor's Liability Insurance; (4) Employer's Liability Insurance; (5) Owner's Liability Insurance; (6) Professional Liability Insurance; (7) Property Damage Insurance; (8) Public Liability Insurance; (9) Special Hazards Insurance.
- Lien** A monetary claim on a property.
- Life cycle** The various developmental stages of a property: predevelopment, development, leasing, operating, and redevelopment (or rehab).
- Life Cycle Cost** A sum of all costs of creation and operation of a facility over a period of time.
- Life Cycle Cost Analysis** A technique used to evaluate the economic consequences over a period of time of mutually exclusive project alternatives.
- Light Pollution** Waste light from building sites that produces glare is directed upward to the sky or is directed off the site.
- Light Shelf** A horizontal element positioned above eye level to reflect daylight onto the ceiling.
- Limit of Liability** The maximum amount which an insurance company agrees to pay in case of loss.
- Lintel** A load-bearing structural member supported at its ends. Usually located over a door or window.
- Liquidity** The ease to which assets can be converted to cash without loss in value.
- Live Load** A temporary and changing load superimposed on structural components by the use and occupancy of the building, not including the wind load, earthquake load, or dead load.
- Load** The electrical power being consumed at any given moment or averaged over a specified period. The load that an electric generating system supplies varies greatly with time of day and to some extent with seasons of year. Also, in an electrical circuit, the load is any device or appliance that is using power.
- Load-Bearing Wall** A support wall that holds floor or roof loads in addition to its own weight.
- Loan to Value Ratio** The ratio of the whole loan principal dollar amount divided by the property's appraised value amount.
- Lumen (lm)** The luminous flux emitted by a point source having a uniform luminous intensity of 1 cd.
- Luminaire** A complete electric lighting unit, including housing, lamp, and focusing and/or diffusing elements; informally referred to as fixture.

- Lux** The International System (SI) unit of illumination. It is the illumination on a surface of one square meter in area on which there is a uniformly distributed flux of 1 lm.
- Manifold** A fitting that has several inlets or outlets to carry liquids or gases.
- Masonry Opening** The actual distance between masonry units where an opening occurs. It does not include the wood or steel framing around the opening.
- Master Specification** A resource specification section containing options for selection, usually created by a design professional firm, which once edited for a specific project becomes a contract specification.
- Master Format** Industry standard for organizing specifications and other construction information, published by CSI and Construction Specifications Canada. Formerly a 5-digit number system with 16 divisions. Now a 6- or 8-digit numbering system with 49 divisions.
- Master Servicer** The institution that acts on behalf of the trustee for the benefit of security holders in collecting funds from the borrower, advancing funds in the event of delinquencies, and, in the event of default, taking the property through the foreclosure process.
- Masterspec** Subscription masterguide specification library published by ARCOM and owned by the American Institute of Architects. <http://www.specguy.com/www.masterspec.com>.
- Mastic** An adhesive used to hold tiles in place; also refers to adhesives used to glue many types of materials in the building process.
- Mechanical Drawing** Applies to scale drawings of mechanical objects.
- Mechanics' Lien** A lien on real property created by statute in all states in favor of person supplying labor or materials for a building or structure for the value of labor or materials supplied by them. In some jurisdictions a mechanic's lien also exists for the value of professional services. Clear title to the property cannot be obtained until the claim for the labor, materials, or professional services is settled.
- Megawatt (MW)** A measurement of power equal to one million watts.
- Megawatt-Hour (MWh)** A measurement of power with respect to time (i.e., energy). One megawatt-hour is equal to 1 MW being used for a period of 1 h or 1 kW being used for 1000 h.
- Mesh** A metal reinforcing material placed in concrete slabs and masonry walls to help resist cracking.
- Mezzanine or Mezzanine Floor** The portion of a story which is an intermediate floor level placed within the story and having occupiable space above and below its floor.
- Modules** A system based on a single unit of measure.
- Modulus of Elasticity (E)** The degree of stiffness of a beam.
- Moisture Barrier** Typically a plastic material used to restrict moisture vapor from penetrating into a structure.
- Mortar** The mixture of cement, sand, lime, and water that provides a bond for the joining of masonry units.
- Mortgage** The mortgage (s) to be made to the Lender to secure the Note and any sums in addition to the Loan Amount advanced by the Lender for completion of the Improvements.
- Multizone HVAC System** A central air-all HVAC system that utilizes an individual supply air stream for each zone; warm and cool air are mixed at the air handling unit to provide supply air appropriate to the needs of each zone; a multizone system requires the use of several separate supply air ducts.
- NAREIT** National Association of Real Estate Investment Trusts National organization that represents the REIT industry.

- Native Vegetation** A plant whose presence and survival in a specific region is not due to human intervention. Certain experts argue that plants imported to a region by prehistoric peoples should be considered native. The term for plants that are imported and then adapt to survive without human cultivation is naturalized.
- Natural Ventilation** Natural exchange of air or movement of air through a building by thermal, wind, or diffusion effects through doors, windows, or other intentional openings in buildings.
- NEC** U.S. National Electrical Code which contains guidelines for all types of electrical installations which should be followed when installing a PV system.
- Negative Leverage** Negative leverage occurs when the current return on equity is diminished by the employment of debt.
- Negligence** Failure to exercise due care under normal circumstances. Legal liability for the consequences of an act or omission frequently depends upon whether or not there has been negligence.
- Net Cash Flow** Generally determined by net income plus depreciation-less principal payments on long-term mortgages.
- Net metering** The practice of exporting surplus solar power during the day (to actual power needs) to the electricity grid, which either causes the home owner electric meter to (physically) go backwards and/or simply creates a financial credit on the home owner's electricity bill. (At night, the homeowner draws from the electricity grid in the normal way.)
- Net Size** The actual size of an object.
- Net Operating Income (NOI)** It is a before tax computation gross revenue less operating expenses, maintenance reserves and an allowance for anticipated vacancy. It is a key indicator of financial strength, measuring a building's ability to generate cash flow.
- Noise Pollution** Environmental pollution made up of harmful or annoying noise. The degree of pollution is usually measured as level of intensity, duration, and frequency. Examples include cars, airplanes, construction equipment, and traffic noise.
- Noise Reduction Coefficient (NRC)** Average of the sound absorption coefficient of the four octave bands 250, 500, 1000, and 2000 Hz rounded to the nearest 0.05.
- Nominal Discount Rate** A discount rate that includes the rate of inflation.
- Nominal Size** The call-out-size. May not be the actual size of the item.
- Nominal Yield** The yield to investors without reduction for inflation.
- Nonbearing Wall** A wall that supports no loads other than its own weight. Some building codes consider walls that support only ceiling loads as nonbearing.
- Nonconforming Work** Implemented work that does not fulfill the requirements of the Contract Documents.
- Nonferrous Metal** They are metals such as copper or brass that contain no iron.
- Nuclear Energy** Energy or power produced by nuclear reactions (fusion or fission).
- Oblique Drawing** A type of pictorial drawing in which one view is an orthographic projection, and the views of the sides have receding lines at an angle.
- Occupiable** A room or enclosed space designed for human occupancy in which individuals congregate for amusement, educational, or similar purposes, or in which occupants are engaged at labor and which is equipped with means of egress, light, and ventilation.
- Off-Gassing** A process of evaporation or chemical decomposition by which vapors are released from materials.
- Ohm** The resistance between two points of a conductor when a constant potential difference of 1V applied between these points produces in the conductor a current of 1 amp.

- Ohm's Law** A simple mathematical formula that allows either voltage, current, or resistance to be calculated when the other two values are known. The formula is: $V = I \times R$, where V is the voltage, I is the current, and R is the resistance.
- Opinions of Probable Costs** Determination of probable costs, a preliminary budget, for a suggested remedy.
- Operating Cost** Any cost of the daily function of a facility.
- Organic Compounds** Chemicals that contain carbon. Volatile organic compounds vaporize at room temperature and pressure. They are found in many indoor sources, including many common household products and building materials.
- Orientation** Position with respect to the cardinal directions, N, S, E, and W.
- Originator** Company that sources and underwrites commercial and/or multifamily mortgage loans.
- Orthographic Projection** A view produced when projectors are perpendicular to the plane of the object. It gives the effect of looking straight at one side.
- Outlet** An electrical receptacle that allows for current to be drawn from the system.
- Ozone** A naturally occurring, highly reactive gas containing triatomic oxygen formed by combination with oxygen in the presence of ultraviolet radiation. This naturally occurring gas builds up in the lower atmosphere as smog pollution, while in the upper atmosphere it forms a protective layer that shields the earth from excessive exposure to damaging ultraviolet radiation.
- Packaged Air-Conditioner** A self-contained unit designed to provide control of air temperature, humidity, distribution, and quality. See also Unitary Air-Conditioner.
- Parapet** A portion of wall extending above the roof level.
- Partial Occupancy** The occupancy by the Owner of a portion of a Projection prior to final completion.
- Particulate** Small pieces of an airborne material. Dusts, fumes, smokes, mists, and fogs are examples. Generally defined as anything that is not a fiber and has an aspect ratio of 3:1.
- Partition** An interior wall.
- Party Wall** A wall dividing two adjoining spaces such as apartments or offices.
- Passive Solar Home** A house that utilizes part of the building as a solar collector, as opposed to active solar, such as PV.
- Patent Defect** A defect in materials, equipment of completed work which reasonably careful observation could have discovered; distinguished from a latent defect, which could not be discovered by reasonable observation.
- Pathogen** Microorganisms typically found in the intestinal tracts of mammals that can cause disease in other organisms or in humans, animals, and plants. They may be bacteria, viruses, or parasites and are found in sewage, in runoff from animal farms or rural areas, and in water used for swimming. Fish and shellfish contaminated by pathogens, or the contaminated water itself, can cause serious illnesses.
- Performance Bond** A bond of the Contractor in which a surety guarantees to the Owner that the Work will be performed in accordance with the contract Documents. Except where prohibited by statute, the Performance Bond is frequently combined with the Labor and Material Payment Bond.
- Performance Specifications** The written material containing the minimum acceptable standards and actions, as may be necessary to complete a project.
- Phase** An impulse of alternating current. The number of phases depends on the generator windings. Most large generators produce a three-phase current that must be carried on at least three wires.

- Photometer** An instrument for measuring light.
- Photovoltaic (PV)** Refers to any device which produces free electrons when exposed to light.
- Photovoltaic (PV) Panel** A term often used interchangeably with PV module (especially in single module systems).
- Photovoltaic system** All the parts connected together that are required to produce solar electricity.
- Pile** A steel or wooden pole driven into the ground sufficiently to support the weight of a wall and building.
- Pillar** A pole or reinforced wall section used to support the floor and consequently the building.
- Planking** A term for wood members having a minimum rectangular section of 1½ in. to 3½ in. in thickness. Used for floor and roof systems.
- Plans** All final drawings, plans, and specifications prepared by the Borrower, Borrower's architects, the General Contractor or Major Subcontractors, and approved by Lender and the Construction Consultant, which describe and show the labor, materials, equipment, fixtures, and furnishings necessary for the construction of the Improvements, including all amendments and modifications thereof made by approved Change Orders (and also showing minimum grade of finishes and furnishings for all areas of the Improvements to be leased or sold in ready-for-occupancy conditions).
- Plat** A map or plan view of a lot showing principal features, boundaries, and location of structures.
- Plenum** An air space (above the ceiling) for transporting air from the HVAC system.
- Plug Load** Refers to all equipment that is plugged into the electrical system, such as task lights, computers, printers, and electrical appliances.
- Polarity** The direction of magnetism or direction of flow of current.
- Pollutant** Generally, any substance introduced into the environment that adversely affects the usefulness of a resource or the health of humans, animals, or ecosystems.
- Polyvinyl Chloride (PVC)** A plastic material commonly used for pipe and plumbing fixtures and as an insulator on electrical cables. A toxic material, which is being replaced with alternatives made from more benign chemicals.
- Positive Leverage** A situation that exists when the simple return on a real estate investment is higher with the use of debt financing than it would be on a free and clear basis. This occurs when the loan constant is lower than the capitalization rate (or lower than the project's estimated IRR).
- Post** A vertical wood structural member generally 4 × 4 (100 mm) or larger.
- Post-and-Beam Construction** A type of wood frame construction using timber for the structural support.
- Postconsumer Materials/Waste** Recovered materials that are diverted from municipal solid waste for the purposes of collection, recycling, and disposition.
- Postconsumer Recycling** Use of materials generated from resident or consumer waste for new or similar purposes such as converting wastepaper from offices into corrugated boxes or newsprint.
- Potable Water** This is water that is suitable for drinking, generally supplied by the municipal water systems.
- Power** Basic unit of electricity equal to the product of current and voltage (in DC circuits). The rate of doing work. Expressed as watts (W). For example, a generator rated at 800W can provide that amount of power continuously. $1W = 1J/s$.

- Precast** A concrete component which has been cast in a location other than the one in which it will be used.
- Preconsumer Materials/Waste** Materials generated in manufacturing and converting processes such as manufacturing scraps and trimmings and cuttings. Includes print overruns, over issue publications, and obsolete inventories. Sometimes referred to as “postindustrial.”
- Present Value** The current value of a past or future sum of money as a function of an investor’s time value of money.
- Pressed Wood Products** A group of materials used in building and furniture construction that are made from wood veneers, particles, or fibers bonded together with an adhesive under heat and pressure.
- Primer** The first coat of paint or glue when more than one coat will be applied.
- Progress Payment** Partial payment made during progress of the Work on account of Work completed and or materials suitably stored.
- Progress Schedule** A diagram, graph, or other pictorial or written schedule showing proposed and actual of starting and completion of the various elements of the Work.
- Project Cost** Total cost of the Project including Construction Cost, professional compensation, land costs, furnishings and equipment, financing, and other charges.
- Projection** A technique for showing one or more sides of an object to give the impression of a drawing of a solid object.
- Project Manual** The volume(s) prepared by the Architect for a Project which may include the bidding requirements, sample forms, and Conditions of the Contract and the Specifications.
- Purlin** A horizontal roof member that is laid perpendicular to rafters to help limit deflections.
- Quarry Tile** An unglazed, machine made tile.
- Quick Set** A fast-curing cement plaster.
- Rafter** A sloping or horizontal beam used to support a roof.
- Radioactivity** The spontaneous emission of matter or energy from the nucleus of an unstable atom (the emitted matter or energy is usually in the form of alpha or beta particles, gamma rays, or neutrons).
- Radius** A straight line from the center of a circle or sphere to its circumference or surface.
- Radon (Rn) and Radon Decay Products** Radon is a radioactive gas formed in the decay of uranium. The radon decay products (also called radon daughters or progeny) can be breathed into the lung where they continue to release radiation as they further decay.
- Rainscreen** A method of constructing walls in which the cladding is separated from a membrane by an airspace that allows pressure equalization to prevent rain from being forced in. Often used for high-rise buildings or for buildings in windy locations.
- Rainwater Harvesting** The practice of collecting, storing, and using precipitation from a catchment area such as a roof.
- Rapidly Renewable** Materials that are not depleted when used. These materials are typically harvested from fast-growing sources and do not require unnecessary chemical support. Examples include bamboo, flax, wheat, wool, and certain types of wood.
- Remote Area Power Supply (RAPS)** A power generation system used to provide electricity to remote and rural homes, usually incorporating power generated from renewable sources such as solar panels and wind generators, as well as nonrenewable sources such as petrol-powered generators.

- Readily Accessible** Describes areas of the subject property that are promptly made available for observation by the field observer at the time of the walk-through survey and do not require the removal of materials or personal property, such as furniture, and that are safely accessible in the opinion of the field observer.
- Record Drawings** Construction drawing revised to show significant changes made during the construction process, usually based on marked-up prints, drawing, and other data furnished by the Contractor to the Architect. Preferable to *As Built Drawings*.
- Rectifier** A device that converts AC to DC, as in a battery charger or converter.
- Recycled Content** The amount of pre- and postconsumer recovered material; usually expressed as a percentage.
- Recycled Material** Material that would otherwise be destined for disposal but is diverted or separated from the waste stream, reintroduced as material feedstock, and processed into marketed end-products.
- Reference Numbers** They consist of numbers used on a drawing to refer the reader to another drawing for more detail or other information.
- Reflectance** The ratio of energy (light) bouncing away from a surface to the amount striking it, expressed as a percentage.
- Refrigerant** A heat transfer fluid employed by a refrigerating process, selected for its beneficial properties (stability, low viscosity, high thermal capacity, appropriate state change points).
- Regionally Manufactured Materials** For purposes of this document, material that must be assembled as a finished product within a 500-mile radius of the project site. Assembly, as used for this definition, does not include on-site assembly, erection, or installation of finished components, as in structural steel, miscellaneous iron, or systems furniture.
- Register** An opening in a duct for the supply of heated or cooled air.
- Regulator** A device used to limit the current and voltage in a circuit, normally to allow the correct charging of batteries from power sources such as solar panels and wind generators.
- Relative Humidity** The amount of water vapor in the atmosphere compared to the maximum possible amount at the same temperature.
- Release of Lien** Instrument executed by a person or entity supplying labor, materials, or professional services on a Project which releases that person's or entity's mechanic's lien against the Project property.
- Remaining Useful Life (RUL)** A subjective estimate based upon observations, or average estimates of similar items, components, or systems, or a combination thereof, of the number of remaining years that an item, component, or system is estimated to be able to function in accordance with its intended purpose before warranting replacement. Such period of time is affected by the initial quality of an item, component, or system, the quality of the initial installation, the quality and amount of preventive maintenance exercised, climatic conditions, extent of use, etc.
- Renewable Energy** Alternative energy that is produced from a renewable source.
- Renewable Resource** A resource that is capable of being restored or replenished (i.e., trees).
- Requisition** A statement prepared by the Borrower in a form approved by the Lender setting forth the amount of the Loan advance requested in each instance and including, if requested by the Lender:
- Resistance (R)** The property of a material which resists the flow of electric current when a potential difference is applied across it, measured in Ohms.
- Resistor** An electronic component used to restrict the flow of current in a circuit. Sometimes used specifically to produce heat, such as in a water heater element.

- Retainage** A sum withheld from progress payments to the contractor in accordance with the terms of the Owner–Contractor Agreement.
- Retaining Wall** A masonry wall supported at the top and bottom designed to resist soil loads.
- R-Factor** A unit of thermal resistance applied to the insulating value of a specific building material.
- Return Air** The air that has circulated through a building as supply air and has been returned to the HVAC system for additional conditioning or release from the building.
- Residual Value** The value of a building or building system at the end of the study period.
- Reuse** A strategy to return materials to active use in the same or a related capacity.
- Roof Drain** A receptacle for removal of roof water.
- Roof Pitch** The ratio of total span to total rise expressed as a fraction.
- Rotation** A view in which the object is apparently rotated or turned to reveal a different plane or aspect, all shown within the view.
- Rough In** To prepare a room for plumbing or electrical additions by running wires or piping for a future fixture.
- Rough Opening** A large opening made in a wall frame or roof frame to allow the insertion of a door or window.
- R-Value** The unit that measures thermal resistance (the effectiveness of insulation); the higher the number, the better the insulation qualities.
- Salvaged Materials** Construction materials recovered from existing buildings or construction sites and reused in other buildings. Common salvaged materials include structural beams and posts, flooring, doors, cabinetry, brick, and decorative items.
- Sanitary Sewer** A conduit or pipe carrying sanitary sewage.
- Scale** The relation between the measurement used on a drawing and the measurement of the object it represents. A measuring device, such as a ruler, having special graduations.
- Schedule of Values** A statement furnished by the Contractor to the Architect reflecting the portions of the Contract sum allocated to the Work and used as the basis for reviewing the Contractor's Applications for Payment.
- Schematic Diagram** A diagram using graphic symbols to show how a circuit functions electrically.
- Scratch Coat** The first coat of stucco, which is scratched to provide a good bond surface for the second coat.
- Sealant** Any material with adhesive properties that is formulated primarily to fill, seal, or waterproof gaps or joints between two surfaces. Sealants include sealant primers and caulks.
- Section** A view showing internal features as if the viewed object has been cut or sectioned.
- Seismicity** The worldwide or local distribution of earthquakes in space and time; a general term for the number of earthquakes in a unit of time, or for relative earthquake activity.
- Septic Tank** A tank in which sewage is decomposed by bacteria and dispersed by drain tiles.
- Sheet Steel** Flat steel weighing less than 5 pounds per square foot.
- Shear Distribution** The distribution of lateral forces along the height or width of a building.
- Shear Wall** A wall construction designed to withstand shear pressure caused by wind or earthquake.
- Shoring** Temporary support made of metal or wood used to support other components.
- Short-Term Costs** Opinions of probable costs to remedy physical deficiencies, such as deferred maintenance, which may not warrant immediate attention but require repairs or replacements that should be undertaken on a priority basis in addition to routine

preventive maintenance. Such opinions of probable costs may include costs for testing, exploratory probing, and further analysis should this be deemed warranted by the consultant. The performance of such additional services are beyond this guide. Generally, the time frame for such repairs is within 1 to 2 years.

Sick Building Syndrome (SBS) Term that refers to a set of symptoms that affect building occupants during the time they spend within the building and diminish or go away during periods when they exit the building. Symptoms cannot be traced to specific pollutants or sources within the building and which may be localized within a specific room or zone (contrast with “Building related illness”).

Sill A horizontal structural member supported by its ends.

Single-Line Diagram A diagram using single lines and graphic symbols to simplify a complex circuit or system.

Single Prime Contract This is the most common form of construction contracting. In this process, the bidding documents are prepared by the architect/engineer for the owner and made available to a number of qualified bidders. The winning contractor then enters into a series of subcontract agreements to complete the work. Increasingly, owners are opting for a “design-build contract” under which a single entity provides design and construction services.

Site A parcel of land bounded by a property line or a designated portion of a public right-of-way.

Site Improvement Landscaping, paving for pedestrian and vehicular ways, outdoor lighting, recreational facilities, and the like, added to a site.

Skylight A relatively horizontal, glazed roof aperture for the admission of daylight.

Slab-on-Grade The foundation construction for a structure with no basement or crawl space.

Smart Growth Managing the growth of a community in such a way that land is developed according to ecological tenets that call for minimizing dependence on auto transportation, reducing air pollution, and increasing infrastructure investment efficiency.

Solar Energy Energy from the sun.

Solar Heat Gain Coefficient Solar heat gain through the total window system relative to the incident solar radiation.

Solar Module A device used to convert light from the sun directly into DC electricity by using the photovoltaic effect. Usually consists of multiple solar cells bonded between glass and a backing material. A typical Solar Module would be 100W of power output (but module powers can range from 1W to 300W) and have dimensions of 2 ft. by 4 ft.

Solar Panel A device that collects energy from the sun and converts it into electricity or heat.

Solar Power Electricity generated by conversion of sunlight, either directly through the use of photovoltaic panels or indirectly through solar-thermal processes.

Solar Reflectance (Albedo) The ratio of the reflected solar energy to the incoming solar energy over wavelengths of approximately 0.3–2.5 μm . A reflectance of 100% means that all of the energy striking a reflecting surface is reflected back into the atmosphere and none of the energy is absorbed by the surface.

Solar Reflectance Index (SRI) A measure of a material’s ability to reject solar heat, as shown by a small temperature rise. It is defined so that a standard black (reflectance 0.05, emittance 0.90) is 0, and a standard white (reflectance 0.80, emittance 0.90) is 100.

Special Conditions A section of the Conditions of the Contract, other than General Conditions and Supplementary Conditions, which may be prepared to describe conditions unique to a particular Project.

- Specifications** A detailed, exact statement of particulars—especially statements prescribing materials and methods—and quality of work for a specific project. A part of the Contract Documents contained in the Project Manual consisting of written requirements for material, equipment, construction systems, standards, and workmanship.
- Specific gravity** The ratio of the weight of a solution to the weight of an equal volume of water at a specified temperature; used with reference to the sulfuric acid electrolyte solution in a lead acid battery as an indicator of battery state of charge. More recently called relative density.
- Stack Effect** Warm air rising, creating a positive pressure area at the top of a building and negative pressure area at the bottom. This effect can overpower the mechanical system and disrupt building ventilation and air circulation.
- Stakeholders** All parties that might be affected by a company's policies and operations, including shareholders, customers, employees, suppliers, business partners, and surrounding communities.
- Statute of Limitations** A statute specifying the period of time with which legal action must be brought for alleged damage or injury, or other legal relief. The lengths of the periods vary from state to state and depend upon the types of legal action. Ordinarily, the period commences with the occurrence of the damage or injury, or discovery of the act resulting in the alleged damage or injury. In construction industry cases, many jurisdictions define the period as commencing with completion of Work or services performed in connection therewith.
- Storm Sewer** A sewer used for conveying rain water, surface water condensate, cooling water, or similar liquid wastes exclusive of sewage.
- Stormwater Runoff** Water volumes that are created during precipitation events and flow over surfaces into sewer systems or receiving waters.
- Stucco** A type of plaster made from Portland cement, sand, water, and a coloring agent that is applied to exterior walls.
- Structural Frame** The components or building system that supports the building's non-variable forces or weights (dead loads) and variable forces or weights (live loads).
- Stud** A light vertical structure member, usually of wood or light structural steel, used as part of a wall and for supporting moderate loads.
- Subcontract** Agreement between a prime Contractor and a Subcontractor for a portion of the Work at the site.
- Subcontractor** A person or entity who has a direct or indirect Contract with a Subcontractor to perform any of the Work at the site.
- Subordination** A lien or call on funds that is junior in the position of one or more other classes.
- Substitution** A material, product, or item of equipment offered in lieu of that specified.
- Superintendent** Contractor's representative at the site who is responsible for continuous field supervision, coordination, completion of the Work and, unless another person is designated in writing by the contractor to the Owner and the Architect, for the prevention of accidents.
- Supervision** Direction of the Work by Contractor's personnel. Supervision is neither a duty nor a responsibility of the Architect as part of professional services.
- Surety Bond** A legal instrument under which one party agrees to answer to another party for the debt, default or failure to perform of a third party.
- Surge** An excessive amount of power drawn by an appliance when it is first switched on. An unexpected flow of excessive current, usually caused by excessive voltage, which can damage appliances and other electrical equipment.

- Survey** Observations made by the field observer during a walk-through survey to obtain information concerning the subject property's readily accessible and easily visible components or systems.
- Sustainable** The condition that meets the needs of present generations without compromising the needs of future generations. Achieving a balance among extraction and renewal and environmental inputs and outputs, as to cause no overall net environmental burden or deficit.
- Sustainable Communities** Communities capable of maintaining their present levels of growth without damaging effects.
- Symbol** Stylized graphical representation of commonly used component parts shown in a drawing.
- Synergy** Action of two or more substances to achieve an effect of which, each is individually incapable. As applied to toxicology, two exposures together (for example, asbestos and smoking) are far more risky than the combined individual risks.
- System** (a process) A combination of interacting or interdependent components assembled to carry out one or more functions.
- Task Lighting** Light provided for a specific task, versus general or ambient lighting.
- Tee** A fitting, either cast or wrought, that has one side outlet at right angles to the run.
- Temper** To harden steel by heating and sudden cooling by immersion in oil, water, or other coolant.
- Template** A piece of thin material used as a true-scale guide or as a model for reproducing various shapes.
- Tensile Strength** The maximum stretching of a piece of metal (rebar, etc.) before breaking; calculated in kps.
- Termite Shield** Sheet metal placed in or on a foundation wall to prevent intrusion.
- Terrazzo** A mixture of concrete, crushed stone, calcium shells, and/or glass, polished to a tilelike finish.
- Thermal Comfort** The appropriate combination of temperature combined with airflow and humidity that allows one to be comfortable within the confines of a building. Individually, an expression of satisfaction with the thermal environment; statistically, such expression of satisfaction from at least 80% of the occupants within a space.
- Thermal Resistance (R)** A unit used to measure a material's resistance to heat transfer. The formula for thermal resistance is: $R = \text{thickness (in inches)}/k$.
- Thermostat** An automatic device controlling the operation of HVAC equipment.
- Third-Party Certification** An independent and objective assessment of an organization's practices or chain of custody system by an auditor who is independent of the party undergoing assessment.
- Three-Phase Power** A combination of three alternating currents in a circuit with their voltages displaced at 120 degrees or one-third of a cycle.
- Timely Access** Entry provided to the consultant at the time of the site visit.
- Timely Completion** The completion of the Work or designated portion thereof on or before the date required.
- Title Insurer** The issuer (s), approved by Interim Lender and Permanent Lenders, of the title insurance policy or policies insuring the Mortgage.
- Tolerance** The amount that a manufactured part may vary from its specified size.
- Topographic Survey** The configuration of a surface including its relief and the locations of its natural and man-made features, usually recorded on a drawing showing surface variations by means of contour lines indicating height above or below a fixed datum.

- Toxicity** A reflection of a material's ability to release poisonous or harmful particulate.
- Toxic Waste** Garbage or waste that can injure, poison, or harm living things, and is sometimes life threatening.
- Transformer** A transformer is a device that changes voltage from one level to another. A device used to transform voltage levels to facilitate the transfer of power from the generating plant to the customer.
- Transient Lodging** A building, facility, or portion thereof, excluding inpatient medical care facilities and residential facilities, which contains sleeping accommodations. Transient lodging may include, but is not limited to, resorts, group homes, hotels, motels, and dormitories.
- Transistor** A semiconductor device used to switch or otherwise control the flow of electricity.
- Trap** A fitting designed to provide a liquid seal which will prevent the back passage of air without significantly affecting the flow of waste water through it.
- Triangulation** A technique for making developments of complex sheet metal forms using geometrical constructions to translate dimensions from the drawing to the pattern.
- Trimmer** A piece of lumber, usually a 2 × 4, that is shorter than the stud or rafter but is used to fill in where the longer piece would have been normally spaced except for the window or door opening or some other opening in the roof or floor or wall.
- Triple Net Lease** A lease that requires the tenant to pay all expenses of the property being leased in addition to rent. Typical expenses covered in such a lease include taxes, insurance, maintenance, and utilities.
- Truss** A prefabricated sloped roof system incorporating a top chord, bottom chord, and bracing.
- Turbulence** Any deviation from parallel flow in a pipe due to rough inner wall surfaces, obstructions, etc.
- UL** Underwriters Laboratories, Inc. A private testing and labeling organization that develops test standards for product compliance. UL standards appear throughout specifications, often in roofing requirements and always in equipment utilizing or delivering electrical power (<http://www.ul.com/>).
- Underwriter** A company that guarantees or participates in a guarantee that an entire issue of stocks or bonds will be purchased.
- Unfaced Insulation** An insulation that does not have a facing or plastic membrane over one side of it.
- Union Joint** A pipe coupling, usually threaded, that permits disconnection without disturbing other sections.
- Urea Formaldehyde** A combination of urea and formaldehyde that is used in some glues and may emit formaldehyde at room temperature.
- Utility Plan** A floor plan of a structure showing locations of heating, electrical, plumbing, and other service system components.
- Vacuum** Any pressure less than that exerted by the atmosphere.
- Valley** The area of a roof where two sections come together to form a depression.
- Valve** A device designed to control water flow in a distribution system; common valve types include globe, gate, butterfly, and check.
- Vapor Barrier** The same as a moisture barrier.
- Vapor Compression Chiller** Refrigeration equipment that generates chilled water via a mechanically driven process using a specialized heat transfer fluid as refrigerant; comprised of four major components: a compressor, condenser, expansion valve, and evaporator; operating energy is input as mechanical motion.

- Variable Air Volume (VAV) HVAC System** A central air–all HVAC system that utilizes a single supply air stream and a terminal device at each zone to provide appropriate thermal conditions through control of the quantity of air supplied to the zone.
- Variable Rate** A loan interest rate that varies over the term of the loan; the rate is usually tied to a predetermined index. Also called adjustable rate.
- Vegetated Roof** A roof that is partially or fully covered by vegetation. By creating roofs with a vegetated layer, the roof can counteract the heat island effect as well as provide additional insulation and cooling during the summer.
- Vehicular Way** A route intended for vehicular traffic, such as a street, driveway, or parking lot.
- Veneer** A thin layer or sheet of wood.
- Veneered Wall** A single-thickness (one-wythe) masonry unit wall with a backup wall of frame or other masonry; tied but not bonded to the backup wall.
- Ventilation** The exchange of air or the movement of air through a building; may be done naturally through doors and windows or mechanically by motor–driven fans.
- Vent** Usually a hole in the eaves or soffit to allow the circulation of air over an insulated ceiling; usually covered with a piece of metal or screen.
- Ventilation Rate** The rate at which indoor air enters and leaves a building. Expressed in one of two ways: the number of changes of outdoor air per unit of time (air changes per hour, or “ach”) or the rate at which a volume of outdoor air enters per unit of time (cubic feet per minute, or “cfm”).
- Vent Stack** A system of pipes used for air circulation and prevent water from being suctioned from the traps in the waste disposal system.
- Vertical Pipe** Any pipe or fitting installed in a vertical position or which makes an angle of not more than 45 degrees with the vertical.
- View** A drawing of a side or plane of an object as seen from one point.
- Vision Glazing** The portion of exterior windows above 2ft. 6 in. and below 7ft. 6 in. that permits a view to the exterior.
- Volatile Organic Compound (VOC)** A highly evaporative, carbon-based chemical substance that produces noxious fumes; found in many paints, caulks, stains, and adhesives. VOCs are capable of entering the gas phase from either a liquid or solid form.
- Volt (E) or (V)** The potential difference across a resistance of 1 ohm when a current of 1 amp is flowing. The amount of work done per unit charge in moving a charge from one place to another.
- Voltage Drop** The voltage lost along a length of wire or conductor due to the resistance of that conductor. This also applies to resistors. The voltage drop is calculated by using Ohm’s Law.
- Voltage Protection** A sensing circuit on an Inverter that will disconnect the unit from the battery if input voltage limits are exceeded.
- Voltage Regulator** A device that controls the operating voltage of a photovoltaic array.
- Waiver of Lien** An instrument by which a person or organization who has or may have a right of mechanic’s lien against the property of another relinquishes such right.
- Warranty** Legally enforceable assurance of quality or performance of a product or work, or of the duration of satisfactory performance. Warranty Guarantee and Guaranty are substantially identical in meaning; nevertheless, confusion frequently arises from supposed distinctions attributed to Guarantee (or Guaranty) being exclusively indicative of duration of satisfactory performance or of a legally enforceable assurance furnished by a manufacturer or other third party. The Uniform Commercial code provisions on Sales (effective in all states except Louisiana) use Warranty but recognize the continuation of the use of Guarantee and Guaranty.

- Waste Pipe** Discharge pipe from any fixture, appliance, or appurtenance in connection with a plumbing system which does not contain fecal matter.
- Waste Water** Spent or used water from a home, farm, community, or industry that contains dissolved or suspended matter.
- Water-Cement Ratio** The ratio between the weight of water to cement.
- Water Hammer** The noise and vibration which develops in a piping system when a column of noncompressible liquid flowing through a pipe line at a given pressure and velocity is abruptly stopped.
- Water Main** The water supply pipe for public or community use.
- Waterproofing** Materials used to protect below- and on-grade construction from moisture penetration.
- Water Table** The level to which water will rise in a well (except artesian wells).
- Watt (W)** The unit of electrical power commonly used to define the electricity consumption of an appliance. The power developed when a current of 1 amp flows through a potential difference of 1V; $1/746$ of a horsepower. $1W = 1J/s$.
- Watt Hour (Wh)** A unit of energy equal to 1W of power being used for 1 h.
- Wetlands** An area that is saturated by surface or ground water and containing vegetation adapted for life under those soil conditions, such as marshes, swamps, estuaries, etc. In stormwater management, it consists of a shallow, vegetated, ponded area that serves to improve water quality and provide wildlife habitat.
- Wind Lift (Wind Load)** The force exerted by the wind against a structure.
- Windpower** Power or energy derived from the wind (via windmills, sails, etc.).
- Wiring (Connection) Diagram** A diagram showing the individual connections within a unit and the physical arrangement of the components.
- Working Drawings** A set of drawings which provide the necessary details and dimensions to construct the object. May include specifications.
- Write-off** The accounting procedure used when an asset has been determined to be uncollectible and is therefore charged off as a loss.
- Wythe** A continuous masonry wall width.
- Xeriscape** A trademarked term referring to water-efficient choices in planting and irrigation design. It refers to seven basic principles for conserving water and protecting the environment. These include: (1) planning and design; (2) use of well-adapted plants; (3) soil analysis; (4) practical turf areas; (5) use of mulches; (6) appropriate maintenance; and (7) efficient irrigation.
- Yield** The effective return on an investment, as paid in dividends or interest. Expressed as a percentage, yield is computed by dividing the market price for a stock or bond into the dividend or interest paid in the preceding period.
- Zenith Angle** The angle between directly overhead and a line through the sun. The elevation angle of the sun above the horizon is 90 degrees minus the zenith angle.
- Zinc** Noncorrosive metal used for galvanizing other metals.
- Zone Numbers** They consist of numbers and letters on the border of a drawing to provide reference points to aid in indicating or locating specific points on the drawing.
- Zoning** The legal restriction that deems that parts of cities be for particular uses, such as residential, commercial, industrial, and so forth.
- Zoning Permit** A permit issued by appropriate governmental authority authorizing land to be used for a specific purpose.

BIBLIOGRAPHY

- Allen, E., Iano, J., 2013. *Fundamentals of Building Construction: Materials and Methods*, sixth ed. John Wiley, New York.
- American Society for Testing and Materials (ASTM), 2001. Standard Practice for Applying Analytical Hierarchy Process (AHP) to Multiattribute Decision Analysis of Investments Related to Buildings and Building Systems: ASTM E1765–11.
- American Society for Testing and Materials (ASTM), 2006. Standard Guide for Property Condition Assessments: Baseline Property Condition Assessment Process: E2018–01.
- American Society of Heating, Refrigeration, and Air-Conditioning Engineers (ASHRAE), 2008. Proposed Standard 189P: Standard for the Design of High-Performance Green Buildings. Second Public Review, July.
- Andreasen, C., Lords, M., Miller, K.R., April 01–04, 2009. Contrasting bid shopping and project buyout. In: *Proceedings of the 45th Annual ASC Conference*, Gainesville, Florida.
- Apgar, M., May–June, 1998. The alternative workplace: changing where and how people work. *Harvard Business Review* 121–135.
- Armer, G.S.T., 2001. *Monitoring and Assessment of Structures*. Spon Press, New York.
- Arnold, C., July 02, 2006. Green Movement Sweeps U.S. Construction Industry. NPR.
- ASHRAE, 2008. Proposed Standard 189P: Standard for the Design of High-performance Green Buildings, Second Public Review, July 2008. Atlanta, GA.
- Askar, N., February 2014. Waste Not, Want Not, Plumbing and Mechanical.
- Bady, S., 2008. Green building programs more about bias than science, expert argues. *Professional Builder*.
- Bennett, FL., 2003. *The Management of Construction: A Project Life Cycle Approach*. Butterworth-Heinemann.
- Bezdek, R.H., 2008. In: Cannon, S.E., Vyas, U.K., Moderators, *Green Building: Balancing Fact and Fiction*. *Real Estate Issues*, vol. 33 (2), pp. 2–5.
- Bonda, P., Sosnowchik, K., 2007. *Sustainable Commercial Interiors*. John Wiley & Sons.
- Brundtland Commission, 1987. *The Brundtland Report: Our Common Future*. U.N. World Commission on Environment and Development.
- Building Owners and Managers Association International, Urban Land Institute, 1999. *What Office Tenants Want*. BOMA/ULI Office Tenant Survey Report.
- Build it Green, *New Home Construction – Green Building Guidelines*, 2007. Edition.
- Burr, A.C., January 30, 2008. CoStar Green Report: the Big Skodowski, CoStar Group.
- Butters, F., 2008. In: Cannon, S.E., Vyas, U.K., Moderators, *Green Building: Balancing Fact and Fiction*. *Real Estate Issues*, vol. 33 (2), pp. 10–11.
- Calow, P., 1998. *Handbook of Environmental Risk Assessment and Management*. Blackwell Science Ltd, Oxford.
- Ching, F.D.K., Shapiro, I.M., March 2014. *Green Building Illustrated*. John Wiley & Sons.
- Hughes, C.J., November 5, 2008. New Skyscraper Stars in National Geographic Show. *Architectural Record*. <http://www.archrecord.construction.com>.
- Coggan, D.A. *Intelligent Building Systems (Intelligent Buildings Simply Explained)*. <http://www.coggan.com/intelligent-building-systems.html>.
- ConsensusDOCS. www.consensusdocs.org.
- Craiger, P., Sheno, S. (Eds.), 2007. *Advances in Digital Forensics III (IFIP International Federation for Information Processing)*. Springer.
- De Chiara, J., Panero, J., 2001. *Time-Saver Standards for Interior Design and Space Planning*. McGraw-Hill, New York.
- Del Percio, S., Spring 2007. What's Wrong with LEED™? American City, Issue 14 Green Building. <http://www.americancity.org/>.

- Deasy, C.M., 1985. *Designing Places for People: A Handbook for Architects, Designers, and Facility Managers*. Whitney Library of Design, New York.
- DiLouie, C., March 2006. *Why Do Daylight Harvesting Projects Succeed or Fail?* Lighting Controls Association.
- Dorgan, C., Cox, R., Dorgan, C. *The Value of the Commissioning Process: Costs and Benefits*, Farnsworth Group, Madison WI, paper presented at the 2002 US Green Building Council Conference, Austin, Texas.
- Dunlap, R.E., Mertig, A.G., 1992. *American Environmentalism: The U.S. Environmental Movement, 1970–1990*. Taylor and Francis, Philadelphia.
- Dworkin, J.F., March 1990. “Waterproofing Below Grade,” *The Construction Specifier*.
- Edwards, S., 1986. *Office Systems – Designs for the Contemporary Workspace*. PBC International Inc., New York.
- Environmental Building News, 2008. *Energy Dashboards: Using Real-Time Feedback to Influence Behavior*, vol. 17 (12), see also other issues at: www.buildinggreen.com/articles/VolumeTOC.cfm?Volume%417.
- EIA, Annual Energy Outlook, Environmental Information Administration, 2008. *Assumptions to the Annual Energy Outlook*, Energy Information Administration, 2008; Cited in *Green Building Facts*, U.S. Green Building Council, November 2008.
- Federal Emergency Management Agency, 2004. FEMA 426, *Reference Manual to Mitigate Potential Terrorist Attacks in High Occupancy Buildings*.
- Fisk, W.J., May 2002. How IEQ affects health, productivity. *ASHRAE Journal*.
- Fisk, W.J., Rosenfeld, A.H., 1998. The indoor environment – productivity and health – and \$\$\$, *Strategic Planning for Energy and the Environment* 17 (4), 53–57.
- Friedman, A., November 21, 2014. *Fundamentals of Sustainable Neighbourhoods*. Springer. 2015 Edition.
- Fuller, S., 2010. Life-cycle cost analysis (LCCA). National Institute of Standards and Technology, (in WBDG).
- Gavin, J., January 2015. *Construction outlook: an economic recovery finds its footing*. Electrical Contractor Magazine.
- Green Building Certification Institute, LEED® Green Associate Candidate Handbook, May 2009.
- General Services Administration (GSA), 2004. *LEED Cost Study—Final Report*, Submitted to the U.S. GBI. Steven Winter Associates, Inc (October).
- Glavinich, T.E., 2008. *Contractor’s Guide to Green Building Construction*. John Wiley and Sons.
- Global Green Building Trends, 2008. *SmartMarket Report*. McGraw Hill Construction.
- Goldsmith, S., 1999. *Designing for the Disabled – the New Paradigm*. Architectural Press, An imprint of Butterworth-Heinemann, Oxford.
- Gore, A., May 2006. *The Future Is Green*, *Vanity Fair: Special Green Issue*.
- Gottfried, D., 2000. *Sustainable Building Technical Manual*. U.S. Green Building Council, U.S. Department of Energy and U.S. Environmental Protection Agency.
- Graham Jr., O.L. (Ed.), 2000. *Environmental Politics and Policy, 1960s–1990s*. Pennsylvania State University Press, University Park.
- Green Building Certification Institute, May 2009. *LEED® Professional Accreditation Handbook*. revised.
- Green Building Initiative (GBI), 2009. *Green Globes®*, a Nationally Recognized Alternative to LEED. www.thegbi.org.
- GSA, October 2004. *LEED Cost Study – Final Report*, Submitted to the U.S. General Services Administration. Steven Winter Associates, Inc.
- Gunn, R.A., Burroughs, M.S., March–April 1996. *Work spaces that work: designing high-performance offices*. *The Futurist* 19–24.
- Haasl, T., Powell, T., Claridge, D., October 2003. *The cost effectiveness of commissioning*. *HPAC Engineering* 20–24.

- Hall, P., October 30, 2014. Green Building Accounts for Nearly 1/4 of U.S. CRE Construction, National Mortgage Professional Magazine.
- Harmon, Koomen, S., Kennon, K.E., 2001. *The Codes Guidebook for Interiors*, second ed. John Wiley & Sons, New York.
- Hartman, T., April 2007. What Does it Really Take to Be an Intelligent Building? The Hartman Company.
- Heerwagen, J., Zagreus, L., 2005. *The Human Factors of Sustainable Building Design: Postoccupancy Evaluation of the Philip Merrill Environmental Center*. U.S. Department of Energy, Annapolis, MD.
- Hellier, C.J., 2001. *Handbook of Nondestructive Evaluation*. McGraw-Hill, New York.
- Heschong Mahone Group, 2003. *Daylighting and Productivity. Studies on behalf of the California Energy Commission's Public Interest Energy Research (PIER) Program*.
- Hess-Kosa, K., 1997. *Environmental Site Assessment Phase I*, second ed. CRC Press.
- Horman, M.J., Riley, D.R., Pulaski, M.H., Magent, C., Dahl, P., Lapinski, A.R., Korkmaz, S., Luo, L., Harding, N.G., 2006. Delivering green buildings: process improvements for sustainable construction. *Journal of Green Building* 1 (1), 123–140.
- Hosey, L., March 2013. Why architects must lead on sustainable design. GreenBiz.
- Houghton-Evans, William, R., 2005. *Well Built?: A Forensic Approach to the Prevention, Diagnosis and Cure of Building Defects*. RIBA Enterprises.
- Howe, J.C., 2010. Overview of green buildings. *National Wetlands Newsletter* 33 (1).
- International Code Council (ICC), 2012a. *International Green Construction Codes*.
- International Code Council (ICC), 2012b. *International Building Code®*.
- International Institute for Sustainable Development (IISD), 2013–2014. *Telling Our Stories, Writing Our Future, Annual Report*.
- Jackson, B.J., 2004. *Construction Management JumpStart*. Wiley Publishing, Inc.
- Jackson, J., 2009. How risky are sustainable real estate projects? An evaluation of LEED and ENERGY STAR development options. *Journal of Sustainable Real Estate* 1 (1).
- Kats, G., 2007. *The Costs and Benefits of Green*, Capital E Analytics.
- Kats, G., 2008. *Greening Buildings and Communities: Costs and Benefits*. Good Energies.
- Kats, G., Alevantis, L., Berman, A., Mills, E., Perlman, J., 2003. *The Costs and Financial Benefits of Green Buildings: A Report to California's Sustainable Building Task Force (SBTF)*.
- Keeler, M., Burk, B., 2009. *Fundamentals of Integrated Design for Sustainable Building*. John Wiley & Sons.
- Kennett, S., 2008. Making BREEAM Robust, Building. <http://www.building.co.uk/story>.
- Kibert, C.J., 2012. *Sustainable Construction – Green Building Design and Delivery*, third ed. John Wiley, New Jersey.
- Koomen-Harmon, S., Kennon, K.E., 2001. *The Codes Guidebook for Interiors*, second ed. John Wiley & Sons, New York.
- Kriss, J., June 2014. USGBC Professional Exams evolving with launch of LEED v4. BNP Media 17.
- Kubal, M.T., 2000. *Construction Waterproofing Handbook*. The McGraw Hill Companies Inc.
- Kubba, S.A.A., 2003. *Space Planning for Commercial & Residential Interiors*. McGraw-Hill, New York.
- Kubba, S.A.A., 2007. *Property Condition Assessments*. McGraw-Hill, New York.
- Kubba, S.A.A., 2008. *Architectural Forensics*. McGraw-Hill, New York.
- Kubba, S., 2012. *Handbook of Green Building Design and Construction: LEED®, BREEAM®, and GREEN GLOBES®*. Elsevier Inc.
- Kubba, S., 2010. *Green Construction, Project Management and Cost Oversight*. Elsevier Inc.
- Langdon, D., 2004. *Costing Green: A Comprehensive Cost Database and Budgeting Methodology*.
- Langdon, D., 2007. *The Cost and Benefit of Achieving Green Buildings*. www.davislangdon.com.

- Lawrence Berkeley National Laboratory, 1996. The Commissioning Process: In Search of a Universal Definition and Application. labs21.lbl.gov/DPM/Assets/a2_sharpless.Pdf.
- Lechner, N., December 2002. Chapter 16, Mechanical Equipment for Heating and Cooling in E-Book.
- LEED[®], August 2008. LEED[™] – NC Green Building Rating System for New Construction & Major Renovations, Version 2.2, USGBC. www.usgbc.org.
- LEED[™] v4 for Building Operations and Maintenance, October 01, 2014. LEED[™] v4 Rating System Selection Guidance (Posted in LEED), 29 July 2014. (USGBC) Updated.
- Levy, M., Salvadori, M.G., Woest, K. (Illustrator), 1994. Why Buildings Fall Down: How Structures Fail. W.W. Norton & Co. Inc.
- Lewis, B.T., Payant, R., 2001. Facility Inspection Field Manual: A Complete Condition Assessment Guide. McGraw-Hill, New York.
- Lippiatt, B.C., Norris, G.A., 1998. Selecting Environmentally and Economically Balanced Building Materials. Sponsored by: National Institute of Standards and Technology.
- Liu, K., 2003. Engineering Performance of Rooftop Gardens through Field Evaluation. National Research Council Canada (NRC).
- Loveland, J., October 2003. Daylight by design. LD+A Magazine.
- Luhmann, T., 2007. Close Range Photogrammetry: Principles, Techniques and Applications. John Wiley, Hoboken, NJ.
- Luo, L., Harding, N.G., 2006. Delivering green buildings: process improvements for sustainable construction. *Journal of Green Building* 1 (1), 123–140.
- Lupton, M., Croly, C., February 2004. Designing for daylight. *Building Sustainable Design Magazine*.
- Lusk, J., Kaplow, S., March 17, 2015. Green Code Mandatory on April 1 for All Building in Baltimore, *Green Building Law*. Updated.
- Macaluso, J., May 2009. An Overview of the LEED[™] Rating System, Empire State Development, *Green Construction Data*.
- Macdonald, S. (Ed.), 2002. *Concrete Building Pathology*. Blackwell Publishing Ltd.
- Madsen, J.J., March 2008. The realization of intelligent buildings. *Buildings Magazine*.
- Mago, S., Syal, M., 2007. Impact of LEED[®]-NC Projects on Construction Management Practices (M.Sc. thesis). Michigan State University.
- Markovitz, M., August 27, 2008. The differences between Green Globes and LEED. *ProSales Magazine*.
- Martín, C., Foss, A., Fall 2006. All that Glitters Isn't Green and Other Thoughts on Sustainable Design for the PATH Partners. National Building Museum.
- Matthiessen, L.F., Morris, P., July 2004. Costing Green: A Comprehensive Cost Database and Budgeting Methodology. Davis Langdon.
- Matthiessen, L.F., Morris, P., 2007. The Cost of Green Revisited. Davis Langdon.
- May, S., 2009. Do Green Design Strategies Really Cost More? DC&D Technologies, Inc., *DCD Construction Magazine*.
- McClain, L.R., 2007. Design-Build Interoperability and Conceptual Design and Development of a Design-Build Management Control System (M.Sc. thesis). Georgia Institute of Technology.
- McGraw-Hill Construction, 2010. 2011 Construction Outlook. SmartMarket Report.
- McGraw-Hill Construction, 2008a. Global Green Building Trends. SmartMarket Report.
- McGraw-Hill Construction, 2008b. The Green Home Consumer: Driving Demand for Green Homes. SmartMarket Report.
- Mendler, S., Odell, W., 2000. *The HOK Guidebook to Sustainable Design*. John Wiley & Sons, New York.
- Mills, E., July 21, 2009. Building Commissioning: A Golden Opportunity for Reducing Energy Costs and Greenhouse-Gas Emissions. California Energy Commission Public Interest Energy Research (PIER).
- Moloney, C., June 26, 2014. LEED v4 changes: new credit categories? *Popular Network*.

- Montoya, M., January 2010. *Green Building Fundamentals*, second ed. Prentice Hall.
- Morris, P., January 2009. *2009 Market Update – A Guide to Working in a Recession*. Davis Langdon.
- Morris, P., Matthiessen, L.F., July 2007. *Cost of Green Revisited*. Davis Langdon.
- Muldavin, S., Summer, 2007. A strategic response to sustainable property investing. *PREA Quarterly*. 33–37. www.muldavin.com.
- Murphy, B.L., Morrison, R.D., 2007. *Introduction to Environmental Forensics*, second ed. Academic Press.
- Nadel, B.A., 2004. *Building Security – Handbook for Architectural Planning and Design*. McGraw-Hill, New York.
- National Institute of Building Sciences. *The Whole Building Design Guide*. www.wbdg.org/design/sustainable.php.
- Needy, K.L., Ries, R., Gokhan, N.M., Bilec, M., Rettura, B., 2004. Creating a framework to examine benefits of green building construction. In: *Proceedings from the American Society for Engineering Management Conference*, October 20–23, Alexandria, VA. pp. 719–724.
- Ochsendorf, J., 2012. *Challenges and Opportunities for Low-Carbon Buildings*. the National Academy of Engineering (NAE).
- Peck, S.W., Callaghan, C., Kuhn, M.E., Bass, B., 1999. *Greenbacks from Green Roofs: Forging a New Industry in Canada*. Canada Mortgage and Housing Corporation.
- Piper, J.E., 2004. *Handbook of Facility Assessment*. Fairmont Press.
- Poynter, D., 1997. *Expert Witness Handbook: Tips and Techniques for the Litigation Consultant*, second ed. Para Publishing.
- Propst, R., 1968. *The Office – a Facility Based on Change*. The Business Press, Elmhurst, IL.
- Prowler, D.D. Prowler & Associates, 2008. Revised and Updated by Vierra, S. Steven Winter Associates, Inc., Whole Building Design.
- Pulaski, M.H., Horman, M.J., Riley, D.R., 2006. Constructability practices to manage sustainable building knowledge. *Journal of Architectural Engineering* 12 (2).
- Ratay, R.T., 2005. *Structural Condition Assessment*. John Wiley & Sons, New York.
- Reznikoff, S.C., 1989. *Specifications for Commercial Interiors*. Whitney Library of Design, New York.
- Rogers, E., Kostigen, T.M., 2007. *The Green Book*. Three Rivers Press, New York.
- Romm, J.J., 1994. *Lean and Clean Management*. Kodansha America Inc.
- Sabo, W., Zahn, J.K. Attorneys at Law. Allowances. www.sabozahn.com/pdf/79.pdf.
- Sale, K., 1993. *The Green Revolution: The American Environmental Movement, 1962–1992*. Hill and Wang, New York.
- Samaras, C., 2004. *Sustainable Development and the Construction Industry: Status and Implications*. Carnegie Mellon University. <http://www.andrew.cmu.edu/user/csamaras>.
- Samarasekera, R., January 27, 2014. *Introducing the New LEED Online* (Posted in LEED).
- Sampson, C.A., 2001. *Estimating for Interior Designers*. Watson-Guptill Publications.
- Sara, M.N., 2003. *Site Assessment and Remediation Handbook*, second ed. CRC.
- Scheer, R., Woods, R., April 2007. *Is There Green in Going Green?* SBM.
- Smith, W.D., Smith, L.H., 2001. *McGraw-Hill On-Site Guide to Building Codes 2000: Commercial and Interiors*. McGraw-Hill Professional Publishing, New York.
- Smart Market Report, 2013. *World Green Building Trends: Business Benefits Driving New and Retrofit Market Opportunities in over 60 Countries*. McGraw-Hill.
- Starr, J., Nicolow, J., October 2007. *How Water Works for LEED*, BNET. CBS Interactive Inc.
- Steven Winter Associates, 1997. *Accessible Housing by Design*. McGraw-Hill, New York.
- Steven Winter Associates, 2004a. *LEED® Applications Guide*. Prepared for U.S. General Services Administration.
- Steven Winter Associates, 2004b. *LEED® Cost Study*. U.S. General Services Administration.
- Steiner, A., November 2014. *Climate change threatens global health security*: UNEP. IBNLive.
- Stodghill, A., August 27, 2008. *LEED™ vs. Green Globes, It's the Environment Stupid*.

- Strong, K.F., Juliana, C.N., 2005. The Basics of Design-Build. Construction Update (May). Gordon & Rees LLP.
- Sullivan, P.J., Agardy Franklin, J., Traub, R.K., 2000. Practical Environmental Forensics: Process and Case Histories. Wiley.
- Syal, M., 2005. Impact of LEED™ Projects on Constructors, AGC Klinger Award Proposal, Michigan State University, Construction Management Program, School of Planning Design and Construction. East Lansing, MI.
- Tilton, R., Howard Jackson, J., 1996. Rigby, Sue Chappell, the Electronic Office: Procedures & Administration, eleventh ed. South-Western Publishing Co., Cincinnati, Ohio.
- TurnerConstruction, 2008. Green Building Market Barometer. www.turnerconstruction.com/greenbuildings.
- Turner, C., Frankel, M., March 04, 2008. Energy Performance of LEED for New Construction Buildings. New Buildings Institute.
- United Nations, December 11, 1987. Report of the World Commission on Environment and Development, General Assembly Resolution 42/187.
- USACE Army LEED™ Implementation Guide, January 15, 2008. Headquarters, U.S. Army Corps of Engineers.
- U.S. Department of Energy, Federal Energy Management Program (FEMP), 2003. The Business Case for Sustainable Design in Federal Facilities.
- U.S. General Services Administration, 2005. Building Commissioning Guide.
- USGBC, United States Green Building Council. www.usgbc.org.
- U.S. Green building Council, 2009. LEED™ Reference Guide for Green Building Design and Construction, for the Design, Construction and Major Renovations of Commercial and Institutional Buildings, Including Core & Shell, and K-12 School Projects. Edition.
- U.S. Green building Council, November 2008. LEED™ 2009 for New Construction and Major Renovations.
- U.S. Green Building Council (USGBC), 2012. LEED® AP Building Design & Construction Study Guide. www.usgbc.org.
- USGBC LEED, June 2013. v4 User Guide. <http://www.cabrillo.edu/~msoik/3/LEED%20v4%20guide.pdf>.
- Vermont Green Building Network. Green building rating systems. www.vgbn.org/gbrs.php.
- Watson, R., November 2012. Attention USA Today: green buildings need to make financial sense. GreenBiz.
- Wilson, S.R., Dunn, S., 2007. Green Downtown Office Markets: A Future Reality. CB Richard Ellis.
- Woods, J.E., 2008. In: Cannon, S.E., Vyas, U.K., Moderators, Green Building: Balancing Fact and Fiction. Real Estate Issues, vol. 33 (2), p. 10.
- Woods, J.E., Fall 2008. Expanding the Principles of Performance to Sustainable Buildings. Focus on Green Building, Entrepreneur Media, Inc.
- Yoders, J., April 01, 2008. Integrated Project Delivery Using BIM, Building Design and Construction.
- Yudelson, J., 2008a. The Green Building Revolution. US Green Building Council.
- Yudelson, J., March 2008b. The Business Case for Green. Yudelson Associates.
- Zelinsky, M., 1998. New Workplaces for New Workstyles. McGraw Hill, New York.
- Zwick, D.C., Miller, K.R., March/April 2004. Project buyout. Journal of Construction Engineering and Management 245–248.

INDEX

Note: Page numbers followed by “f” indicate figures, “t” indicate tables.

A

- A-Series (Owner/contractor agreements), 764–773
- A101–2007 standard form, 764
- A101CMa–1992 standard form. *See* A132–2009 standard form
- A102–2007 standard form, 765
- A103–2007 standard form, 765
- A105–1993 standard form. *See* A105–2007 standard form
- A105–2007 standard form, 765
- A107–2007 standard form, 766
- A111–1997 standard form. *See* A102–2007 standard form
- A114–2001 standard form. *See* A103–2007 standard form
- A121CMc–2003 standard form. *See* A133–2009 standard form
- A131CMc–2003 standard form. *See* A134–2009 standard form
- A132–2009 standard form, 766
- A133–2009 standard form, 767
- A134–2009 standard form, 767
- A141–2004 standard form, 768
- A142–2004 standard form, 768
- A151–2007 standard form, 769
- A175ID–2003 standard form. *See* A151–2007 standard form
- A195–2008 standard form, 769
- A201–2007 standard form, 769
- A201CMa–1992 standard form. *See* A232–2009 standard form
- A205–1993 standard form. *See* A105–2007 standard form
- A232–2009 standard form, 770
- A251–2007 standard form, 770
- A275ID–2003 standard form. *See* A251–2007 standard form
- A295–2008 standard form, 771
- A305–1986 standard form, 771
- A310–2010 standard form, 771
- A312–2010 standard form, 771
- A401–2007 standard form, 772
- A441–2008 standard form, 772
- A503–2007 standard form, 772
- A511–1999 standard form. *See* A503–2007 standard form
- A511CMa–1993 standard form. *See* A533–2009 standard form
- A533–2009 standard form, 772
- A701–1997 standard form, 773
- A751–2007 standard form, 773
- A775ID–2003 standard form. *See* A751–2007 standard form
- AABC Group. *See* Associated Air Balance Council Commissioning Group (AABC Group)
- Abbreviated property condition report
 - appendix, 930
 - consultant’s certification, 929–930
 - general descriptive information, 925–927
 - general physical condition, 927–928
 - procedures and protocol
 - documentation review, 922
 - research and interviews, 923
 - site visit, 923
 - project identification, 923
 - project summary, 923–925
 - purpose, 921
 - scope, 922
 - summary of findings, 928–929
- ABC International, Inc., 919, 921
- ABGR. *See* Australian Building Greenhouse Rating (ABGR)
- Absorption chiller, 504
- AC. *See* Alternating current (AC)
- Accelerating admixture, 309
- Acceptance, 636–639
- Acclimate, 466f
- Accreditation, 576–577
- ACE. *See* Alliance for Construction Excellence (ACE)
- ACEM. *See* Association of Consulting Engineers Malaysia (ACEM)

- ACGIH. *See* American Conference of Governmental Industrial Hygienists (ACGIH)
- Acid rain, 612
- Acoustical testing, 907
- ACQ. *See* Alkaline copper quaternary (ACQ)
- Active solar energy systems, 530
- Adhesives, 263–265
- Adjustable frequency drives (AFDs), 529
- Adjusted Internal Rate of Return (AIRR), 603–604
- ADR. *See* Alternative dispute resolution (ADR)
- Advanced coatings on steel pipes, 544
- AECB. *See* Association for Environment Conscious Building (AECB)
- aecXML, 246
- Aerators, 435
- AES. *See* Architecture Engineering System (AES)
- AFDs. *See* Adjustable frequency drives (AFDs)
- AFUE. *See* Annual fuel utilization efficiency (AFUE)
- Ag-res boards. *See* Agricultural-residue boards (Ag-res boards)
- AGC. *See* Associated General Contractors (AGC)
- Agency CM, 151
- Agricultural-residue boards (Ag-res boards), 300
- Agrifiber products, 262
- AHJ. *See* Authority Having Jurisdiction (AHJ)
- AHP. *See* Analytical hierarchy process (AHP)
- AHUs. *See* Air Handling Units (AHUs)
- AIA. *See* American Institute of Architects (AIA)
- AIA contract documents, 763–791, 764t.
See also ConsensusDOCS contract documents; Engineers joint contract documents committee contract documents (EJCDC)
contract administration and project management form, 782–791
exhibits, 781
miscellaneous documents, 780–781
other agreements, 775–780
owner/architect agreements, 773–775
owner/contractor agreement, 764–773
- Air
- air-cooled chillers, 503
 - air-heating collectors, 484–485
 - cleaners, 403
 - entraining admixtures, 310
 - exchange rate, 401
 - filters, 506–508
 - filtration, 399–400
 - handlers, 466
 - pollution damage, 28–29
 - purification, 400–401
- Air conditioning systems, 486–492. *See also* Heating systems; Ventilation
- central air conditioning systems, 488–489
 - packaged systems, 491–492
 - split system, 489–491, 491f
 - vapor compression refrigeration, 487
 - window air conditioning units, 487–488, 488f
- Air Handling Units (AHUs), 466
- Air Leakage (AL), 280
- Air-Krete, 333
- Airman first-Class Nadine Barclay, 534f
- AIRR. *See* Adjusted Internal Rate of Return (AIRR)
- Air-water systems, 494
- AL. *See* Air Leakage (AL)
- Alarms
- and security, 468
 - systems, 568–570
- Alkaline copper quaternary (ACQ), 294
- All-air systems, 492
- All-water systems, 492–494
- Allergic rhinitis, 381
- Alliance for Construction Excellence (ACE), 238–239
- Allowances, 686–693
- budget allowances, 692–693
- Alternating current (AC), 519–520
- breaker panel, 536
 - electricity, 534
- Alternative dispute resolution (ADR), 857–858, 862–863, 872–883

- techniques, 872–879, 873f, 875t
arbitration, 874–877
assisted negotiation, 878–879
mediation, 877–878
unassisted negotiation, 878–879
- Aluminum, 279
wiring, 515–516
- American Conference of Governmental
Industrial Hygienists (ACGIH), 404
- American Institute of Architects (AIA), 8,
77, 112, 166, 600, 681, 712,
881–882, 890
A141–2014 Agreement, 160
Document A142–2014, 160
Document E202, 249–250
Document G744–2014, 160, 212–213
Forms, 168
G702 format, 168
G704 standard form, 212–213
- American National Standards Institute
(ANSI), 76–77, 514–515
- American Recovery and Reinvestment Act
(ARRA), 607, 805–806
- American Society for Testing and Materials
International (ASTM), 742–743
- American Society of Civil Engineers
(ASCE), 881–882
- American Society of Heating, Refrigerating
and Air-Conditioning Engineers
(ASHRAE), 43, 356, 621, 631–632,
645, 742
ASHRAE 52.1 and 52.2, 507
Green Guide, 150–151, 461–462
Standard, 17–18, 123, 444–446
- American Society of Testing and Materials
(ASTM), 273–274
- American Subcontractors Association
(ASA), 677
- American Tree Farm System (ATFS), 88–89
- Americans with Disabilities Act (ADA), 906
- Amperage (A or Amp), 511–512
- Amtrak generator, 519f
- Analytical hierarchy process (AHP),
612–613
- Animal allergens, 377–381
- Annual fuel utilization efficiency (AFUE),
475–476
- ANSI. *See* American National Standards
Institute (ANSI)
- Ants, 380
- Applying MERV Rating, 507–508
- Arbitration, 874–877
- Archicad software, 229
- Architect/Administrator
Certificate of Substantial Completion,
212–214
Certified Copy of Final Punchlist, 215
- Architect's field report, 787
- Architect's Supplemental Instructions (ASI),
219
- Architecture Engineering System (AES),
229–230
- ARRA. *See* American Recovery and
Reinvestment Act (ARRA)
- Array DC disconnect, 535
- Array mounting rack, 535
- As-built drawings, 211–212, 685
- As-built survey, 913
- ASA. *See* American Subcontractors
Association (ASA)
- Asbestos, 360–362
- Asbestos Hazard Emergency Response Act,
361
- ASCE. *See* American Society of Civil
Engineers (ASCE)
- ASD. *See* Aspirating smoke detectors (ASD)
- ASHRAE. *See* American Society of
Heating, Refrigerating and
Air-Conditioning Engineers
(ASHRAE)
- ASHRAE Technical Committee
(ASHRAE TC), 123
- ASI. *See* Architect's Supplemental
Instructions (ASI)
- Aspirating smoke detectors (ASD), 560
- Assisted negotiation, 878–879
- Associated Air Balance Council Commis-
sioning Group (AABC Group), 659
- Associated General Contractors (AGC),
677, 890
- Association for Environment Conscious
Building (AECB), 105
- Association of Consulting Engineers
Malaysia (ACEM), 101–102

- ASTM. *See* American Society for Testing and Materials International (ASTM); American Society of Testing and Materials (ASTM)
- At-risk CM delivery approach, 151–152
- ATFS. *See* American Tree Farm System (ATFS)
- Atmospheric Pollutants, 612
- Australian Building Greenhouse Rating (ABGR), 93–94
- Authority Having Jurisdiction (AHJ), 639–640
- Autodesk, 229, 234f
- Automatic sprinkler systems, 545–548
- B**
- B-Series (Owner/Architect Agreements), 773–775
- B801CMA–1992 standard form. *See* C132–2009 standard form
- Backup generator, 536
- Bacteria, 375–377
- Ballast, 523
- Baltimore City Planning Commission, 45
- Bamboo, 327–330
- Bank account, 837–838
- BAS. *See* Building Automation Systems (BAS)
- Baseboard heating, 474
- Baseline water consumption calculations, 436–438
establishing FTE occupants' water use, 436–438, 437t
- Basis of Design (BOD), 447, 621
- Battery bank, 535
- BCA. *See* Building Commissioning Association (BCA)
- BCP. *See* Brownfield Cleanup Program (BCP)
- BECs. *See* Building Enclosure Councils (BECs)
- BEE. *See* Bureau of Energy Efficiency (BEE); Indian Bureau of Energy Efficiency (BEE)
- BER. *See* Building Energy Rating system (BER)
- Best management practices (BMPs), 438
- Bid shopping, 675–681
- Bid solicitation and building contracts types, 752–763
cost-plus contract, 756–757
GMP, 757–758
labor, 762–763
lump sum, 753–756
negotiated contract, 763
project management contract, 761–762
unit price contract, 758–761, 760f
- BIFMA. *See* Business and Institutional Furniture Manufacturers Association (BIFMA)
- BIM. *See* Building Information Modeling (BIM)
- Binding, 874–876
process and building contracts types, 748–752
CM as constructor, 752
DB, 751–752
DBB, 749–751, 750f
requirements, 713
- BioBased insulation, 333
- Biodegradable (B) building materials, 324, 325t
- Biological contaminants, 372–377
bacteria and viruses, 375–377
mold and mildew, 373–374
- Bioswales, 438–441, 440f
- BIPVs. *See* Building integrated photovoltaic systems (BIPVs)
- BiQ. *See* Building Intelligence Quotient (BiQ)
- BLA. *See* Building Loan Agreement (BLA)
- Blackwater, 418–420
- Blakely Hall, 73, 74f
- BLCC. *See* Building Life-Cycle Cost (BLCC)
- BMPs. *See* Best management practices (BMPs)
- BMVBS. *See* Bundesministerium für Verkehr, Bau und Stadtentwicklung (BMVBS)
- BOD. *See* Basis of Design (BOD)
- Boilers, 501–503
- BOMA. *See* Building Owners and Managers Association (BOMA)

- Bonding requirements, 713
- Break-even analysis, 617
- BREEAM. *See* Building Research Establishment's Environmental Assessment Method (BREEAM)
- BRI. *See* Building Related Illness (BRI); Building-related illness (BRI)
- Bricks-and-mortar office, 806–808
- “Bridging”, 161
- Brownfield Cleanup Program (BCP), 22–23
- Brownfield sites, 121
- Brundtland Report, 27
- BSD. *See* Building Systems Design (BSD)
- Budget allowances, 692–693
- Budget setting, 812–819
 - accounting and bookkeeping, 818–819
 - decorating or remodeling, 816
 - employees and required forms, 813–815
 - expense report, 816–818, 817f
 - furniture, 815
 - internet service, 816
 - miscellaneous issues, 819
 - office equipment, 815
 - start-up costs, 813, 814f
 - suppliers, 816
- Builder's risk, 886–887
- Builders and manufacturers incentives, 607
- Building
 - condition review, 906–907
 - construction values in United States, 445–446
 - contract agreements
 - AIA contract documents, 763–791
 - bid solicitation and building contracts types, 752–763
 - bidding process and building contracts types, 748–752
 - ConsensusDOCS contract documents, 791–801
 - EJCDC contract documents, 801–803
 - function, 612
 - litigation, 853–854
 - materials and finishes, 405–409
 - resources for locating healthy building materials, 407–409
 - toxic building materials, 405–407
 - reuse, 313–315
 - interior nonstructural elements, 315
 - LEED requirements, 315
 - maintaining structural elements, 314
 - technologies and strategies, 314–315
- Building Automation Systems (BAS), 461–468, 513
 - air handlers, 466
 - alarms and security, 468
 - CAV, 466
 - central plant, 467
 - CHW systems, 467–468
 - condenser water system, 468
 - controller, 465
 - hot water system, 468
 - lighting, 465–466
 - multicriteria intelligent sensor, 466f
 - occupancy sensors, 465
 - VAV, 466–467
 - VAV hybrid systems, 467
- Building commissioning (Cx), 621–622, 623f
- Building commissioning, 127
 - benefits, 628–631, 629f
 - commission, 626–627
 - factors affecting cost, 632–634
 - goals and objectives, 631–632
 - long-term cost implications, 634
 - whole-building commissioning, 627f
- Building Commissioning Association (BCA), 621, 653–654
- Building Enclosure Councils (BECs), 451
- Building Energy Rating system (BER), 106
- Building Energy Summit, 129
- Building envelope, 449–460. *See also* Heating, ventilating, and air conditioning (HVAC)
 - exterior wall systems, 451–458
 - weatherproofing, 459–460
- Building Information Modeling (BIM), 41, 130–133, 227, 229, 771, 795, 859
 - benefits, 233–238
 - building form with, 243–246
 - BIM to “green apartment building”, 244f
 - customizing BIM, 244–245
 - making transformation, 245–246
 - building systems with, 248–250

Building Information Modeling (*Continued*)

- AIA Document E202, 249–250
- virtual best practices, 248–249
- buildingSMART International, 231
- CAD, 228–229
- challenges/risks, 233, 238–240
- future of, 250–256
- IPD—sharing intelligent data for sustainable solutions, 241–243
- Miami Science Museum, 232f
- process, 232–233
- relationship of BIM, 230f
- Building integrated photovoltaic systems (BIPVs), 530–531
- Building Intelligence Quotient (BiQ), 75
- Building Life-Cycle Cost (BLCC), 618
- Building Loan Agreement (BLA), 187–189
- Building Owners and Managers Association (BOMA), 15–16, 35, 590–591
 - Seattle survey, 115
- Building performance, 61–62
- Building Related Illness (BRI), 856–857
- Building Research Establishment's Environmental Assessment Method (BREEAM), 10–11, 75, 91, 106
 - fit-out certification scheme, 108
 - Green Leaf, 76, 82
- Building Systems Design (BSD), 708
- Building-related illness (BRI), 353, 358–359, 596, 654
- buildingSMART International, 231
- Bundesministeriums für Verkehr, Bau und Stadtentwicklung (BMVBS), 97
- Bureau of Energy Efficiency (BEE), 98–99
- Business
 - form, 832–838
 - bank account, 837–838
 - federal employer identification number, 834–835
 - name and legal structure, 832–834
 - incentives, 607
 - operation license, 835–836
 - plan, 808–812
- Business and Institutional Furniture Manufacturers Association (BIFMA), 743
- Byggherkravene, 254

C

- C-Series (Agreements), 775–780
- C&D. *See* Construction and Demolition (C&D)
- C101–1993 standard form, 775
- C106–2007 standard form, 776
- C132–2009 standard form, 776
- C141–1997 standard form. *See* C401–2007 standard form
- C191–2009 standard form, 776
- C195–2008 standard form, 777
- C196–2008 standard form, 777
- C197–2008 standard form, 778
- C198–2010 standard form, 778
- C199–2010 standard form, 779
- C401–2007 standard form, 779
- C441–2008 standard form, 779
- C727–1992 standard form, 780
- C801–1993 standard form. *See* C101–1993 standard form
- CA. *See* Copper azole (CA)
- CABA. *See* Continental Association for Building Automation (CABA)
- CAD. *See* Computer-aided drafting (CAD)
- Cadmium, 406
- CAFS. *See* Certified Air Filter Specialist (CAFS)
- CaGBC. *See* Canada Green Building Council (CaGBC)
- CalGreen, 121–122
- California Department of Resources Recycling and Recovery (CalRecycle), 10, 12
- California High Performance Schools (CHPS), 404, 408
- California Integrated Waste Management Board (CIWMB), 265
- California Title 24 standards, 121–122
- California Urban Water Conservation Council (CUWCC), 432
- CalRecycle. *See* California Department of Resources Recycling and Recovery (CalRecycle)
- Canada Green Building Council (CaGBC), 89–90
- Canadian Home Builders' Association (CHBA), 94

- Canadian Standards Association (CSA), 76, 344
- Capitalization, 812–819
accounting and bookkeeping, 818–819
decorating or remodeling, 816
employees and required forms, 813–815
expense report, 816–818, 817f
furniture, 815
internet service, 816
miscellaneous issues, 819
office equipment, 815
start-up costs, 813, 814f
suppliers, 816
- Carbon dioxide (CO₂), 27–28, 56, 128, 356, 366–367
extinguishers, 557–558
- Carbon monoxide (CO), 356, 366–367
- Carpet and Rug Institute (CRI), 268–269
- CASBEE. *See* Comprehensive Assessment System for Building Environmental Efficiency (CASBEE)
- Cash flow, 662, 694
- CAV. *See* Constant Volume Air-Handling Unit (CAV)
- CB. *See* Circuit breaker (CB)
- CBECS. *See* Commercial Buildings Energy Consumption Survey (CBECS)
- CCA. *See* Chromated copper arsenate (CCA)
- CDs. *See* Construction documents (CDs)
- Ceiling-mounted sprinkler head, 547f
- Cellulose based fiber wall board, 300
- Central air conditioning systems, 488–489
- Central boiler, 474–475
- Central heating, 474–475
- Central plant, 467
- CEQ. *See* Council of Environmental Quality (CEQ)
- Certificate for payment, 783–784, 788
- Certificate of Compliance, 212
- Certificate of Occupancy (CO), 209, 215–216, 912
- Certificate of Substantial Completion, Architect/Administrator's, 212–214
- Certification, 59, 210–224. *See also* Project Status Report (PSR)
architect/administrator
Certificate of Substantial Completion, 212–214
Certified Copy of Final Punchlist, 215
as-built drawings, 211–212
ASI, 219
CO, 215–216
commissioning and warranties, 216–218
Contractor's Certificate of Compliance, 212
final waivers of lien, 216, 217f–218f
FOIL, 223–224
LEED, 64
letter. *See* Sample pay approval letter
Shop Drawing submittal and review procedure, 220–223
time extensions, 219–220
- Certified Air Filter Specialist (CAFS), 507–508
- Certified Copy of Final Punchlist, 215
- Certified Green Professional (CGP), 109
- CFC. *See* Chlorofluorocarbon (CFC)
- CFLs. *See* Compact fluorescent lamps (CFLs)
- CGL policies. *See* Commercial General Liability policies (CGL policies)
- CGP. *See* Certified Green Professional (CGP)
- Change Order, 189–192, 190f, 912
- Charge controller, 535
- CHBA. *See* Canadian Home Builders' Association (CHBA)
- Checklists, 637–638, 641
- Chilled water systems (CHW systems), 464, 467–468, 503–504
- China, BIM, 255–256
- Chlorinated hydrocarbons, 264
- Chlorofluorocarbon (CFC), 447, 471–472
- CHP. *See* Combined heat and power systems (CHP)
- CHPS. *See* California High Performance Schools (CHPS); Collaborative for High Performance Schools (CHPS)
- Chromated copper arsenate (CCA), 294
- Churn rate, 587
- CHW systems. *See* Chilled water systems (CHW systems)

- CIE sky. *See* Commission Internationale de l'Eclairage sky (CIE sky)
- CIEB program. *See* Continental Improvements of Existing Buildings program (CIEB program)
- CII. *See* Confederation of Indian Industry (CII)
- Circuit breaker (CB), 509
- CIWMB. *See* California Integrated Waste Management Board (CIWMB)
- Cladding. *See* Siding
- Class A fire extinguishers, 554
- Class B fire extinguishers, 555–556
- Class C fire extinguishers, 556
- Class D fire extinguishers, 556–557
- Class I standpipe system, 553
- Class II standpipe system, 553
- Class III standpipe system, 554
- Class K fire extinguishers, 557
- Climate-based controls, 417
- Clogged filter, 506, 506f
- Closed specifications, 709–710. *See also* Open specification
- Closing costs, 670
- CM. *See* Construction manager (CM)
- CMA. *See* Construction Manager Agent (CMA)
- CMES. *See* Mexico Green Building Council (CMES)
- CMU. *See* Concrete–masonry unit (CMU)
- CO. *See* Certificate of Occupancy (CO)
- Co-insured Lender, 187–189
- Coatings, 265–267
- Codes and standards, 570–571
- “Cold creep”, 515–516
- Collaborative documents (300 Series), 794
- Collaborative for High Performance Schools (CHPS), 746
- low-emitting materials, 408
- Combined heat and power systems (CHP), 607
- Combustion-generated contaminates, 366–368
- CO, 367
- CO₂, 366–367
- NO₂, 367–368
- Commercial Buildings Energy Consumption Survey (CBECS), 80
- Commercial General Liability policies (CGL policies), 885–886
- Commercial off-the-shelf (COTS), 462–464
- Commercial real estate (CRE), 593
- Commission Internationale de l'Eclairage sky (CIE sky), 389
- Commissioning, 621–622, 625–626, 639–640, 646–648
- enhanced, 652–653
- RCx, 653–656
- warranty phase, 656–659
- fundamental, 648–651
- operation and maintenance, 126–127
- plan structure, 636, 636t
- provider, 639–640
- responsibilities, 641–642
- service provider, 639–646
- and warranties, 216–218
- Commissioning agent (CxA). *See* Commissioning authority (CxA)
- Commissioning authority (CxA), 628, 639–646
- CT, 642–644
- provider responsibilities, 641–642
- qualifications and certification, 644–646
- Compact fluorescent lamps (CFLs), 523
- Company Blogs, 850
- Company logo, 849
- Compartmentation, 565–567
- Compliance, 636–639
- Components of HVAC systems, 496–508, 497f. *See also* Heating, ventilating, and air conditioning (HVAC)
- air filters, 506–508
- boilers, 501–503
- CHW systems, 503–504
- condensers, 505
- cooling towers, 504–505
- delivery components, 498
- distribution components, 498
- ductwork, 498–499
- grills, registers, and diffusers, 499–500
- source components, 497
- thermostats, 500–501

- Components of sustainable design and construction
 - building industry in United States, 56–57
 - challenge of Green Globes Rating System, 73–90
 - Environmental Protection Program, 58
 - environmentally friendly techniques, 55
 - green building evaluation systems, 62–63
 - green rating standards, 91–110
 - green/sustainable building, 55
 - Porter School of Environmental studies, 100f
 - USGBC LEED certification and rating system, 63–73
- Composite wood. *See* Engineered lumber
- Composting toilets, 430–432, 431f
- Comprehensive Assessment System for Building Environmental Efficiency (CASBEE), 10–11, 95
 - certification, 100
 - system, 100–101
- Compression chiller, 504
- Computer
 - computer-generated models, 227–228
 - computerized specification writing systems, 736–740
 - energy simulation, 144–145
 - estimating programs, 617–619
 - technology, 736
- Computer-aided drafting (CAD), 228–229, 736
- Concrete, 309–313, 453–454
- Concrete–masonry unit (CMU), 310
- Condensers, 487, 505
 - water system, 468
- Condensing, 475–476
- Confederation of Indian Industry (CII), 98
- Confidentiality, 881–883
- ConsensusDOCS contract documents, 747–748, 791–801. *See also* AIA
 - contract documents; Engineers joint contract documents committee
 - contract documents (EJCDC)
- Conservation, 124
- Constant Volume Air-Handling Unit (CAV), 466
- Construction
 - consultant, 163, 167
 - contingency, 664–668, 688–692
 - failures, 863–865
 - management contracts (500 Series), 797
 - manager, 150–151
 - permits, 912
 - phase, 138–139
 - progress schedule, 684
 - schedule, 913
 - and schedule of values, 203–204
 - waste management, 317–320, 424–425
 - LEED requirements, 317–320
- Construction and Demolition (C&D), 258, 424–425
- Construction and Real Estate Network (CORENET), 256
- Construction documents (CDs), 621–622
- Construction manager (CM), 137, 748–749, 751f
 - as constructor, 752
- Construction Manager Agent (CMa), 644
- Construction Project Information Committee (CPIC), 251–252
- Construction Specifications Canada (CSC), 704
- Construction Specifications Institute (CSI), 637–638, 704
 - green product specification
 - execution, 735–736
 - general, 735
 - products, 735
 - UniFormat, 737
- Constructor, CM as, 752
- Consumer incentives, 606–607
- Continental Association for Building Automation (CABA), 75
- Continental Improvements of Existing Buildings program (CIEB program), 81
- Contingency, 686–693
 - clause, 664–668
 - construction, 688–692
 - funding, 690–691
- Contract
 - conditions, 713–714
 - documents, 138, 200–202, 212–213

Contractor general obligations and responsibilities, 682

Control(s), 518
 mode sprinklers, 542
 valve, 554

Controller, 465

Cooler air, 476–477

Cooling towers, 420, 504–505

Copper azole (CA), 294

CORENET. *See* Construction and Real Estate Network (CORENET)

Cork, 330–331

Corporate image creation, 820–822
 advertising and promotion, 820–821, 821f
 marketing company services, 821–822

Corrosion monitoring devices, 544

Cost
 considerations of green design, 586–587
 of debt, 613–614
 effectiveness, 599–600, 603, 613, 616, 618
 estimating, 603
 forecasting, 235

Cost-efficient CPVC piping, 544

Cost-plus contract, 756–757
 advantages, 757
 disadvantages, 757

COTS. *See* Commercial off-the-shelf (COTS)

Council of Environmental Quality (CEQ), 146

CPIC. *See* Construction Project Information Committee (CPIC)

CRE. *See* Commercial real estate (CRE)

CRI. *See* Carpet and Rug Institute (CRI)

CSA. *See* Canadian Standards Association (CSA)

CSC. *See* Construction Specifications Canada (CSC)

CSI. *See* Construction Specifications Institute (CSI)

CT. *See* CxA team (CT)

Curtain walls, 455

CUWCC. *See* California Urban Water Conservation Council (CUWCC)

Cx. *See* Building commissioning (Cx)

CxA. *See* Commissioning authority (CxA)

CxA team (CT), 642–644

D

D-Series (Miscellaneous Documents), 780–781

D101–1995 standard form, 780

D200–1995 standard form, 780

D503–2011 standard form, 780

Daily work log, 202–203

Database of State Incentives for Renewables & Efficiency (DSIRE), 19

Databases, 662

Date of Commencement, 181

Daylight factor (DF), 387–396

Daylighting, 387–396
 design, 539
 shades and shade controls, 396
 and visual comfort, 390–396

DB. *See* Design-build (DB)

dba permit. *See* Doing business as permit (dba permit)

DBB. *See* Design-bid-build (DBB)

DBIA. *See* Design-Build Institute of America (DBIA)

DEAP Energy Group, 165

Debris recycling, 894–895

Deconstruction, 324

Deductions for Commercial Buildings, 541

Deferred seasonal testing, 657

Delivery components, 498

Delivery devices, 498

Deluge
 systems, 549–551
 valve, 550

Denmark, BIM, 254–255

Department of Energy (DOE), 6–7, 18, 58, 399–400, 415–416, 451, 617, 659

Department of General Services (DGS), 322

Department of Planning and Development (DPD), 20

Descriptive specifications, 710

Design Professional, 173

Design-bid-build (DBB), 749–751, 750f
 delivery method, 148

Design-build (DB), 749, 750f, 751–752
 documents, 795

Design-Build Institute of America (DBIA), 154–155

- Designer of record (DOR), 137, 198–199, 635
 Detention ponds, 438–441
 Deutsche Gesellschaft für nachhaltiges Bauen e.V. (DGNB), 97
 DEWA. *See* Dubai Electricity and Water Authority (DEWA)
 DF. *See* Daylight factor (DF)
 DGNB. *See* Deutsche Gesellschaft für nachhaltiges Bauen e.V. (DGNB)
 DGS. *See* Department of General Services (DGS)
 Di(2-ethylhexyl) phthalate, 406
 Diffusers, 499–500
 Digital data licensing agreement, 776
 Direct Capital Costs, 586
 Direct current (DC)
 electricity, 534
 motor, 517
 Direct expansion units (DX units), 926
 Direct operating costs, 586
 Discounted Payback (DPB), 603–604
 Distribution components, 498
 District heating, 474–475
 Documentation, 636–639
 DOE. *See* Department of Energy (DOE); U. S. Department of Energy (DOE)
 Doing business as permit (dba permit), 834–835
 Domain name registration, 844
 Domestic central air conditioners, 489, 490f
 DOR. *See* Designer of record (DOR)
 DPB. *See* Discounted Payback (DPB)
 DPD. *See* Department of Planning and Development (DPD)
 DPR Construction, 40–41
 Dry chemical extinguishers, 557
 Dry pipe systems, 548–549
 Dry-type transformers, 520–521
 Drywall. *See* Gypsum wall board
 DSIRE. *See* Database of State Incentives for Renewables & Efficiency (DSIRE)
 Dual flush toilets, 429–430
 Dubai Electricity and Water Authority (DEWA), 104–105
 Ductwork, 498–499
 Durability and replacement costs, 611–612
 elements of durability, 611–612
 Durable flooring, 269
- E**
 E-Series, 781
 e-SPECS software, 737–739, 738f
 E&O Insurance. *See* Errors and Omissions Insurance (E&O Insurance)
 E.O. *See* Executive Order (E.O.)
 E201–2007 standard form, 781
 E202–2008 standard form, 781
 EA. *See* Economic analysis (EA); Energy and Atmosphere (EA)
 EAQ. *See* Environmental Air Quality (EAQ)
 Early Suppression Fast Response (ESFR), 543
 Earth-coupled heat pump. *See* Geothermal heat pumps (GHPs)
 Earthen building materials, 275–277
 Earthen construction, 275
 Earthen flooring, 276
 ECBC. *See* Energy Conservation Building Code (ECBC)
 Eco-labeling, 860
 EcoLogo, 407–408
 Economic analysis (EA), 601–603, 614f
 Credit 3 for Commercial Interiors, 446–447
 tools and methods, 613–619
 break-even analysis, 617
 computer estimating programs, 617–619
 present-value analysis, 613–616
 relevant codes and standards, 619
 sensitivity analysis, 616–617
 Economic Analysis Package (ECONPACK), 617–618
 Economic benefits of green building, 582–586, 583f, 584t
 ECONPACK. *See* Economic Analysis Package (ECONPACK)
 EcoRock, 282
 Ecoroofs. *See* Extensive green roofs
 EDG. *See* Envelope Design Guide (EDG)
 EDGE. *See* Excellence in Design for Greater Efficiencies (EDGE)

- EER. *See* Energy-Efficiency Rating (EER)
- EIFS. *See* Exterior Insulation Finish System (EIFS)
- EIN. *See* Employer Identification Number (EIN)
- EJCDC. *See* Engineers Joint Contract Documents Committee contract documents (EJCDC)
- Electric baseboard heaters, 474
- Electric heating, 473–474
- Electric resistance, 474
- Electrical components, 513–521
 - aluminum wiring, 515–516
 - emergency power, 518–519
 - grounding, 517
 - meters, 515
 - motors, switches, and controls, 517–518
 - panelboards, 515
 - service connections, 513–514
 - service outlets and receptacles, 517
 - switches and controls, 518
 - switchgear and switchboards, 514–515
 - transformers, 519–521, 521f
- Electrical current, 512
- Electrical power systems, 508–529. *See also* Lighting systems; Solar energy systems
 - amps, 511–512
 - deficiencies in, 510f
 - electrical components, 513–521
 - volts, 511–513
 - watts, 511–513
- Electromagnetic sensitivity (EMS), 409
- Electronic faucets, 434
- Elements of durability, 611–612
- EMCOR Group, Inc., 245
- Emergency lighting systems, 519–521
- Emergency power, 518–519
- Emirates Green Building Council (EmiratesGBC), 104
- Employee health, 590–591
- Employer Identification Number (EIN), 834
- EMS. *See* Electromagnetic sensitivity (EMS); Environmental Management System (EMS)
- Energy and Atmosphere (EA), 66, 444, 544
- Energy Conservation Building Code (ECBC), 98–99
- Energy efficiency, 121–123
- Energy Efficient Commercial Building Tax Deduction, 44
- Energy Independence and Security Act, 128–129
- Energy Performance Certificate (EPC), 106
- Energy Performance of Building Directive (EPBD), 105
- Energy performance optimization, 447–448
- Energy Policy Act (EPAAct), 16–18, 743
- Energy Policy and Conservation Act (EPCA), 519–520
- Energy Savings Performance Contract (ESPC), 612, 616
- Energy Service Company (ESCO), 612
- ENERGY STAR, 92–93
 - ENERGY STAR-Certified buildings, 2
 - label, 341, 483–484
 - program, 44, 110
- ENERGY-10 tool, 618
- Energy-Efficiency Rating (EER), 93–94
- Engagement letter, 901
- Engineered lumber, 295
- Engineers Joint Contract Documents Committee contract documents (EJCDC), 168, 748, 801–803. *See also* AIA contract documents; ConsensusDOCS contract documents
 - construction, 802
 - contract document sets, 803
- Enhanced commissioning, 448, 652–653
- Enhanced refrigerant management, 448
- Envelope Design Guide (EDG), 451
- Environmental Air Quality (EAQ), 13
- Environmental issues, 523–524
- Environmental Management System (EMS), 32, 58
- Environmental Performance Certificate (EPC), 107
- Environmental Product Declarations (EPDs), 343–344

- Environmental Protection Agency (EPA),
571, 92–93, 114–115, 265, 357,
413–414, 416, 472, 743
- Environmental Protection Program, 58
- EPA. *See* Environmental Protection Agency (EPA)
- EPAct. *See* Energy Policy Act (EPAct)
- EPBD. *See* Energy Performance of Building Directive (EPBD)
- EPC. *See* Energy Performance Certificate (EPC); Environmental Performance Certificate (EPC)
- EPCA. *See* Energy Policy and Conservation Act (EPCA)
- EPDs. *See* Environmental Product Declarations (EPDs)
- EPS. *See* Expanded PS (EPS)
- Errors and Omissions Insurance (E&O Insurance), 887–888
policies, 885, 887–888
- ESCO. *See* Energy Service Company (ESCO)
- ESFR. *See* Early Suppression Fast Response (ESFR)
- ESPC. *See* Energy Savings Performance Contract (ESPC)
- Evaporatively cooled chillers, 503
- Excellence in Design for Greater Efficiencies (EDGE), 103–104
- Executive Order (E.O.), 146–147
- Expanded PS (EPS), 304
- Expert witness, 871–872
- Extended coverage sprinklers, 543
- Extensive green roofs, 291–293
- Exterior doors, 458
- Exterior Insulation Finish System (EIFS),
454–455
- Exterior lighting systems, 526–527
- Exterior wall air conditioning units. *See* Window air conditioning units
- Exterior wall systems, 451–458
concrete, 453–454
curtain walls, 455
EIFS, 454–455
masonry wall systems, 452
siding, 455–457
stone wall systems, 452–453
windows, exterior doors, and skylights, 458
- F**
- Facility Condition Index (FCI), 246
- FACP. *See* Fire alarm control panel (FACP)
- Factory Mutual (FM), 551
- FAIA. *See* Fellow, American Institute of Architects (FAIA)
- Fair Housing Accessibility Guidelines (FHAA), 906
- FAR. *See* Federal Acquisition Regulation (FAR)
- Fast-response sprinklers, 543
- Faucets, 434–436
aerators, 435
electronic faucets, 434
metering faucets, 435
- FCI. *See* Facility Condition Index (FCI)
- FCMAA. *See* Fellow, Construction Management Association of America (FCMAA)
- Federal Acquisition Regulation (FAR),
748–749
- Federal Appliance Standards, 483–484
- Federal Emergency Management Agency,
451
- Federal employer identification number,
834–835
- Federal Energy Management Program (FEMP), 30, 146, 615
- Federal Envelope Advisory Committee, 451
- Federal government, 7–8
- Federal Ministry of Transport, Building and Urban Affairs. *See* Bundesministeriums für Verkehr, Bau und Stadtentwicklung (BMVBS)
- Federal Rules of Civil Procedure (FRCP),
879
- Federal tax credits for energy efficiency,
540–541
- Federal Trade Commission (FTC), 322
- Federal Unemployment taxes (FUE taxes),
838
- Fellow, American Institute of Architects (FAIA), 241
- Fellow, Construction Management Association of America (FCMAA),
241

- FEMP. *See* Federal Energy Management Program (FEMP)
- FF&E. *See* Furniture, furnishings, and equipment (FF&E)
- Fiber glass insulation products, 498–499
- Fiber optics, 524–525
glass block walls, 526f
- Fiberglass, 332
- File Transfer Protocol (FTP), 845
- Filtration, 398–404
air filtration, 399–400
air purification, 400–401
types of wind catchers, 398f
- Finance charges and other costs, 612–613
- Financial plan, 811
- Finland, BIM, 253
- Fire alarm control panel (FACP), 560–561, 568
- Fire doors, 561–570
alarm systems and notification systems, 568–570
compartmentation, 565–567
exit routes, 563–565
fire stopping systems, 567f
fire-rated door and glass lites classification, 562t
- Fire extinguishers. *See* Handheld fire extinguishers
- Fire hose systems, 553–554
- Fire protection systems, 542
- Fire resistance, 284
- Fire sprinkler control valve assembly, 546f
- Fire sprinkler systems, 541
- Fire suppression systems, 541–571
codes and standards, 570–571
components, 543f
fire doors, 561–570
handheld fire extinguishers, 554–558
LEED contributions, 544–545
smoke and heat detection systems, 558–561
sprinkler systems, 545–554
- Fire Suppression Systems Association (FSSA), 541
- Fire Zones, 565
- Fire-rated door assemblies, 563
- Firestop, 565–566
- First costs, 601
- Fixed fee contract, 753–756
- Flexible vinyl flooring, 334
- Flooring systems, 268–274
carpet, 268–270
PVC, 270–272
tile production, 272–274
- FloorScore, 270
- Flow-optimized showerheads, 435–436
- Fluid delivery time, 544
- Fluorescent lamps, 523
- Fluorocarbons. *See* Perfluorocarbons (PFCs)
- Fly ash, 310
- FM. *See* Factory Mutual (FM)
- Foam–water sprinkler systems, 551–552
- FOIL. *See* Freedom of Information Letters (FOIL)
- Forced draft towers, 505, 505f
- Forest Stewardship Council (FSC), 57, 88–89, 260, 743
- Formaldehyde (HCHO), 369–370
- FPT. *See* Functional performance testing (FPT)
- Framing techniques, 300–309
insulating concrete formwork
Quad-Lock system, 307f
isometric drawing, 301f–302f
- France, BIM, 252
- FRCP. *See* Federal Rules of Civil Procedure (FRCP)
- Freedom of Information Letters (FOIL), 223–224
- Front-end project analysis, 165–167
construction documents review, 166–167
- FSC. *See* Forest Stewardship Council (FSC)
- FSC-certified wood, 344
- FSSA. *See* Fire Suppression Systems Association (FSSA)
- FTC. *See* Federal Trade Commission (FTC)
- FTE building occupants. *See* Full-time equivalent building occupants (FTE building occupants)
- FTP. *See* File Transfer Protocol (FTP)
- FUE taxes. *See* Federal Unemployment taxes (FUE taxes)
- Full-time equivalent building occupants (FTE building occupants), 65, 436, 438

Functional performance testing (FPT),
634–635

Fundamental commissioning, 648–651
of building systems, 447
checklist of systems, 651f

Fundamental refrigerant management, 447

Furnace heating, 475–476

Furniture, furnishings, and equipment
(FF&E), 769

G

G-Series (Contract Administration and
Project Management Forms),
782–791

G601–1994 standard form, 782

G602–1993 standard form, 782

G605–2000 standard form. *See* G801–2007
standard form

G606–2000 standard form. *See* G802–2007
standard form

G607–2000 standard form. *See* G803–2007
standard form

G612–2001 standard form, 782

G701–2001 standard form, 783

G701CMA–1992 standard form, 783

G701S–2001 standard form, 783

G702–1992 standard form, 783

G702CMA–1992 standard form. *See*
G732–2009 standard form

G702S–1992 standard form, 784

G703–1992 standard form, 784

G703S–1992 standard form, 784

G704–2000 standard form, 784

G704CMA–1992 standard form, 785

G704DB–2004 standard form, 785

G705–2001 standard form, 785

G706–1994 standard form, 785

G706A–1994 standard form, 786

G707–1994 standard form, 786

G707A–1994 standard form, 786

G709–2001 standard form, 786

G710–1992 standard form, 787

G711–1972 standard form, 787

G712–1972 standard form, 787

G714–2007 standard form, 787

G714CMA–1992 standard form, 787

G715–1991 standard form, 788

G716–2004 standard form, 788

G722CMA–1992 standard form. *See*
G736–2009 standard form

G723CMA–1992 standard form. *See*
G737–2009 standard form

G732–2009 standard form, 788

G736–2009 standard form, 788

G737–2009 standard form, 789

G744–2014 Agreement, 160

G801–2007 standard form, 789

G802–2007 standard form, 789

G803–2007 standard form, 789

G804–2001 standard form, 789

G805–2001 standard form. *See* G705–2001
standard form

G806–2001 standard form, 790

G807–2001 standard form, 790

G808–2001 standard form, 790

G808A–2001 standard form, 790

G809–2001 standard form, 790

G810–2001 standard form, 791

Gallon per flush (gpf), 425–426

Gas compressor, 487

Gas-fired hot water boiler, 501–503, 502f

GB. *See* Green building (GB)

GBA. *See* Green Building Alliance
(GBA)

GBC. *See* Green Building Council (GBC)

GBCA. *See* Green Building Council of
Australia (GBCA)

GBCI. *See* Green Building Certification
Institute (GBCI); Green Business
Certification, Inc. (GBCI)

GBCSA. *See* Green Building Council
South Africa (GBCSA)

GBELS. *See* Green Building Evaluation and
Labeling System (GBELS)

GBF. *See* Green Building Facilitator (GBF)

GBI. *See* Green Building Index (GBI);
Green Building Initiative (GBI)

GBTC program. *See* Green Building Tax
Credit program (GBTC program)

GC. *See* General contractor (GC)

GEI. *See* GreenGuard Environmental
Institute (GEI)

GEM. *See* Global Environmental Method
(GEM)

- General Contracting Documents (200 Series), 792
- General contracting project delivery method. *See also* Design-bid-build (DBB)
- General contractor (GC), 239, 891
- General ledger, 818
- General Services Administration (GSA), 6–7, 90, 114–115, 451, 625–626
- GeoExchange heat pump. *See* Geothermal heat pumps (GHPs)
- Geothermal heat pumps (GHPs), 481–482, 483f
- German Sustainable Building Council. *See* Deutsche Gesellschaft für nachhaltiges Bauen e.V. (DGNB)
- Germany, BIM, 252–253
- GHPs. *See* Geothermal heat pumps (GHPs)
- Glazing, 273–274
- Global Environmental Method (GEM), 76
- Global warming potential (GWP), 448
- GMP. *See* Guaranteed maximum price (GMP)
- GOBAS. *See* Green Olympic Building Assessment System (GOBAS)
- gpf. *See* Gallon per flush (gpf)
- gpm. *See* Gallon per flush (gpf)
- Graphics Interchange Format (. gif), 737
- Grassroots marketing, 830–831
- Gravity and Forced Air systems, 476–477
- Gray water, 112–113
- Gray water demonstrations, 423–424
- Gray water systems, 419
- Green building (GB), 1–9
 - Australia’s Sydney Opera House, 52f
 - costs
 - durability and replacement costs, 611–612
 - finance charges and other costs, 612–613
 - operation, repair, and maintenance costs, 610
 - operational energy, 608–609, 608f, 610t
 - water costs, 608–609, 608f, 610t
 - decision makers and parties for LEED, 34f
 - design, 2
 - and delivery, 139–141
 - earth’s greenhouse effect, 29f
 - emerging directions, 37–53
 - establishing measurable green criteria, 27–37
 - evaluation systems, 62–63
 - GB Tool, 10–11
 - green professionals, 12
 - high-performance building, 10
 - human activities cause climate change, 28f
 - incentives, barriers, and benefits, 14–27
 - global economic recession, 15–16
 - “Green Building Barometer” survey, 16
 - risks of building green, 26–27
 - sustainable communities, 22–26
 - tax deductions and incentives, 16–19
 - materials and products
 - building and material reuse, 313–317
 - construction waste management, 317–320
 - forestry certification and certified wood, 342–346
 - green materials, 259
 - green office equipment, 339–342
 - LCA and LCCA of building materials and products, 346–349
 - low-emitting materials, 261–313
 - miscellaneous building elements, 281–284
 - multifaceted concept, 258–259
 - natural *vs.* synthetic materials, 259–261
 - North Carolina, 258
 - rapidly renewable materials, 327–339
 - recycled materials, 320–324
 - regional materials, 325–327
 - roofing, 284–293
 - storage and collection of recyclable, 261
 - third-party certification, 349–351
 - USGBC, 257
 - wood, 293–309
 - in Portland, 11
 - principles and components, 116–133
 - programs, 20–21

- standard, 99
- University of Pennsylvania building projects, 24f
- water conservation, 14
- Green Building Addendum, 747
- Green Building Alliance (GBA), 68–70
- Green Building Certification Institute (GBCI), 63–64, 70–71, 350
- Green Building Certification Program, 102–103
- Green Building Committee, 62
- Green Building Council (GBC), 103
- Green Building Council of Australia (GBCA), 93–94
- Green Building Council South Africa (GBCSA), 103–104
- Green Building Evaluation and Labeling System (GBELS), 62
- Green Building Facilitator (GBF), 747
- Green Building Impact Report, 4–6
- Green Building Index (GBI), 101–102, 109–110
- Green Building Initiative (GBI), 25, 74–75, 82, 91–92, 855
- Green Building Tax Credit program (GBTC program), 22–23
- Green Business Certification, Inc. (GBCI), 98–99
- Green business development
 - business form, 832–838
 - capitalization, 812–819
 - creating corporate image, 820–822
 - creating successful business plan, 808–812
 - detering factor, 805–806
 - home-based office *vs.* bricks-and-mortar office, 806–808
 - importance of selling yourself, 825–831
 - dressng for success, 825–828, 826f–827f
 - self introductions, 828–831
 - incentives, 838–840
 - insurance, 832–838
 - internet and internet marketing, 840–851
 - licenses, permits, 832–838
 - setting budget, 812–819
 - start-up costs, 812–819
 - strategies, 838–840
 - taxes, 838–840
 - track and identify sources for leads, 822–824, 824f
- Green construction management, 150–154
- Green design
 - and building economics
 - analysis of green construction costs, 578
 - economic analysis tools and methods, 613–619
 - green building costs, 608–613
 - green organizations, 577–578
 - LCC, 599–604
 - tax benefits and incentives, 604–607
 - in U. S. construction sector, 573–574
 - and construction process, 115
 - design process for high performance buildings, 142–147
 - green building, 111–112
 - green certification systems, 114–115
 - green construction management, 150–154
 - green project delivery systems, 147–148
 - high performance design strategies, 133–142
 - traditional green design-bid-build project delivery, 148–150
 - U. S. Green Building Council, 114f
 - costs and benefits, 578–599, 579f
 - cost considerations of green design, 586–587
 - economic benefits of green building, 582–586
 - employee health, 590–591
 - external economic effects, 598–599
 - improved tenant, 590–591
 - increased productivity, 587–590
 - increased property values and marketability, 593–595
 - increased recruitment and retention, 591–592
 - green design-build project delivery, 154–161
 - advantages and disadvantages of design-build, 157–159
 - AIA design-build documents, 159–161

- Green design (*Continued*)
 - design-build process basics, 155
 - factors, 159
 - miscellaneous indirect benefits, 595–598
 - enhanced image, 595
 - future proofing, 596, 597f
 - reducing risk, 595–596
 - self reliance, 596–598
 - principles of green design, 116–128
 - commissioning operation and maintenance, 126–127
 - energy efficiency, 121–123
 - holistic approach, 119
 - indoor environmental quality and safety, 125–126
 - integrated design, 120–121
 - livable communities and neighborhoods, 127–128
 - materials and resources, 124–125
 - native and drought-resistant planting, 120f
 - site selection, 121
 - state-of-the-art building technologies, 118
 - waste management issues, 126
 - water efficiency and conservation, 124
 - strategies, 134–135
- Green economy, 599
- Green features influence on insurance
 - policies in United States, 892–897
- Green Globes, 25, 74–77, 92, 109–110
 - alternative to LEED, 82–90
 - assessment categories of, 77f
 - GBI and, 74–77
 - v1 assessment protocol, 77
- Green Globes Canada system, 82
- Green Globes Rating System, challenge of, 73–90
 - Blakely Hall, 73, 74f
 - Green Globes
 - alternative to LEED, 82–90
 - assessment categories of, 77f
 - GBI and, 74–77
 - v1 assessment protocol, 77
 - rating levels in United States, 79f
 - software subscriptions costs, 84t
- Green Globes-NC, 87
- Green label plus, 408
- Green material and products claims, 860
- Green office equipment, 339–342
- Green Olympic Building Assessment System (GOBAS), 95
- Green performance-related claims, 860–862
- Green Power, 449
- Green premiums, 580
- Green project
 - commissioning, 621–625, 646–659
 - building commissioning objectives, 626–634
 - CxA, 639–646
 - fundamental, 625–626
 - planning commissioning process, 634–639
 - Construction Consultant, 163
 - cost management, 694–701, 695f
 - cost planning, 698–701, 700f
 - risk allowance management, 696–698
 - successful cost management procedures, 694–696
 - delivery systems, 147–148
 - project evaluation and analysis, 164–165
 - final certification and project closeout, 210–224
 - front-end project analysis, 165–167
 - loan disbursements, 186–199
 - PSR preparation, 199–210
 - quality assurance, 224–225
 - quality control, 224–225
 - requisition format, 167–173
 - site visits and observations, 173–186
- Green rating standards, 91–110
- Green roof systems, 288–290
- Green Schools Guide, 23–24
- Green Seal, Scientific Certification Systems (SCS), 265
- Green Seal-Certified products, 407
- Green specifications and documentation
 - computerized specification writing systems, 736–740
 - developing project manual, 712–722
 - greening specifications, 733–736
 - liability issues, 740–742
 - master systems, 704–705
 - referenced standards, 742–746

- specification organization and format, 722–733
 - section format, 726–733
- specifications, 705–708
 - types and categories, 709–712
- Green Star, 103
 - environmental rating system, 93–94
- Green technology, 599
- “Green” flooring, 268
- Greenbuild, 9
- GreenFormat, 707–708
- GreenGuard Environmental Institute (GEI), 408
- GREENGUARD Environmental Institute, 743
- Greenhouse effect, 27–28, 29f, 56
- Greenhouse gases, 444
 - emissions, 1, 146–147
- Greening Buildings and Communities, 580
- Greening specifications, 733–736
 - CSI green product specification outline, 735–736
- Greenwashing, 585, 734–735, 855, 860
 - claims, 860
- Grid-intertied PV systems. *See* Grid-Tied Solar System
- Grid-Tied Solar System, 536–537
- Grills, 499–500
- Ground source heat pump. *See* Geothermal heat pumps (GHPs)
- Ground-loop system classifications, 482t
- Grounding, 517
- GSA. *See* General Services Administration (GSA)
- Guaranteed maximum price (GMP), 151–152, 681, 751–752, 757–758, 795
- GWP. *See* Global warming potential (GWP)
- Gypsum wall board, 281–282
- H**
- Halogenated flame retardants (HFRs), 407
- Halon extinguishers, 565
- Handheld fire extinguishers, 554–558, 555f
 - classification, 554–557
 - labeling, 556f, 557
 - types, 557–558
- Hard costs, 670, 690
- “Hardwood”, 293
- Harmful gas, 366–367
- Harmonics, 528–529. *See also* Lighting systems; Electrical power systems
 - harmonic reduction, 529
- HBAs. *See* Homebuilder associations (HBAs)
- HBN. *See* Healthy Building Network (HBN)
- HCFCs. *See* Hydrochlorofluorocarbons (HCFCs)
- HCH. *See* Hexachlorocyclohexane (HCH)
- Health hazards, 361–362
- Healthy building materials, resources for locating, 407–409
- Healthy Building Network (HBN), 405
- Heartwood, 294
- Heat, 612
 - detection systems, 558–561
 - detectors, 561
 - pumps, 480
- Heating, ventilating, air conditioning and refrigeration (HVAC&R), 447
- Heating, ventilating, and air conditioning (HVAC), 400, 468–508, 469f. *See also* Components of HVAC systems
 - air conditioning systems, 486–492
 - basic types, 492–494, 493f
 - deficiencies, 495–496
 - heating systems, 473–485
 - refrigerants, 471–472
 - requirements, 494–495
 - types, 472–473
 - ventilation, 486
- Heating systems, 473–485. *See also* Air conditioning systems; Ventilation
 - central heating, 474–475
 - electric baseboard heaters, 474
 - electric heating, 473–474
 - furnace heating, 475–476
 - GHPs, 481–482, 483f
 - ground-loop system classifications, 482t
 - heat pumps, 480
 - hot water heating systems, 478–479
 - hybrid systems, 482–484

- Heating systems (*Continued*)
 radiant heating, 476
 RCCs, 480–481
 solar thermal collectors, 484–485
 steam heating systems, 479–480
 warm air heating systems, 476–478
- Heavy metals, 406
- Heavy mold infestation causing by water penetration, 858f
- Heschong Mahone Group (HMG), 391, 589
- HETs. *See* High-efficiency toilets (HETs)
- HEUs. *See* High-efficiency urinals (HEUs)
- Hexachlorocyclohexane (HCH), 372
- HFRs. *See* Halogenated flame retardants (HFRs)
- HID lamps. *See* High-intensity discharge lamps (HID lamps)
- High performance design strategies, 133–142
 design process for high performance buildings, 142–147
 green building design and delivery, 139–141
 green design strategies, 134–135
 IDP, 135–139, 136f
 integrated multidisciplinary project team, 141–142
- High profile roofs. *See* Intensive green roofs
- High-efficiency toilets (HETs), 428–429
- High-efficiency urinals (HEUs), 432
- High-intensity discharge lamps (HID lamps), 524
- High-Performance Buildings (HPB), 37
- High-performance buildings, 55, 73–74, 95
- High-pressure sodium (HPS), 523–524
- HMG. *See* Heschong Mahone Group (HMG)
- Holistic design, 111–112
- Homasote, 300
- Home-based office, 806–808
- Homebuilder associations (HBAs), 23–24
- Hong Kong, BIM, 255
- Hot water system, 468
 heating systems, 478–479
- HPB. *See* High-Performance Buildings (HPB)
- HPS. *See* High-pressure sodium (HPS)
- HVAC. *See* Heating, ventilating, and air conditioning (HVAC)
- HVAC&R. *See* Heating, ventilating, air conditioning and refrigeration (HVAC&R)
- Hybrid systems, 482–484
- Hydrocarbons, 370–371
- Hydrochlorofluorocarbons (HCFCs), 471–472
- I**
- I-BEAM. *See* IAQ Building Education and Assessment Model (I-BEAM)
- IAI. *See* International Alliance for Interoperability (IAI)
- IAQ. *See* Indoor air quality (IAQ)
- IAQ Building Education and Assessment Model (I-BEAM), 401
- ICC. *See* International Code Council (ICC)
- ICFs. *See* Insulated concrete forms (ICFs)
- ID. *See* Innovation and Design (ID)
- IDA. *See* International Dark-Sky Association (IDA)
- IDC. *See* Interest during construction (IDC)
- IDP. *See* Integrated Design Process (IDP)
- IEA. *See* International Energy Agency (IEA)
- IECC. *See* International Energy Conservation Code (IECC)
- IEEE. *See* Institute of Electrical and Electronic Engineers (IEEE)
- IEQ. *See* Indoor environmental quality (IEQ)
- IEQ monitoring program, 411–412
- IES. *See* Illuminating Engineering Society of North America (IESNA)
- IESNA. *See* Illuminating Engineering Society of North America (IESNA)
- IFC. *See* Industry Foundation Class (IFC)
- IGBC. *See* Indian Green Building Council (IGBC)
- IgCC. *See* International Green Construction Code (IgCC)
- III reports. *See* Insurance Information Institute reports (III reports)

- Illuminating Engineering Society of North America (IESNA), 526–527
- ILSR. *See* Institute for Local Self Reliance (ILSR)
- Incandescent lamps, 523–524
- Incentives, 604–607, 838–840
- Increased productivity, 587–590
- Indian Bureau of Energy Efficiency (BEE), 98–99
- Indian Green Building Council (IGBC), 35–36, 61
- Indoor air quality (IAQ), 4, 77–78, 112–113, 356, 360–381, 443–444, 585, 625–626, 856–857
- asbestos, 360–362
 - biological contaminants, 372–377
 - combustion-generated contaminants, 366–368
 - investigating IAQ, 382–383
 - lead, 364–366
 - organic contaminants, 368–372
 - radon, 362–364
 - rodent, insect, and animal allergens, 377–381
- Indoor environmental quality (IEQ), 2, 58, 353, 470–471, 856–857
- baselines for building performance, 355
 - best practices, 409–412
 - BRI, 358–359
 - building materials and finishes, 405–409
 - causes of indoor pollution, 355–356
 - concentration of contaminants, 354f
 - factors affecting, 359–397
 - daylighting and daylight factor, 387–396
 - IAQ, 360–381
 - noise pollution, 384–386
 - steps to reducing pollutant exposure, 381–383
 - thermal comfort, 383–384
 - views, 397
 - filtration, 398–404
 - and safety, 125–126
 - SBS, 356–357
 - ventilation, 398–404
- Induced draft towers, 505, 505f
- Industry Foundation Class (IFC), 231–232, 246
- “Information Age”, 525
- Initial costs, 601
- Innovation and Design (ID), 70
- Innovative wastewater technologies, 419–421, 421f
- Inorganic contaminants, 360
- Insects, 377–381, 612
- Inspection & Valuation International, Inc. (IVI), 856
- Institute for Local Self Reliance (ILSR), 596–597
- Institute of Electrical and Electronic Engineers (IEEE), 514–515
- Insulated concrete forms (ICFs), 306
- Insulation, 331–333
- Insurance, 832–838, 840
- requirements, 713
- Insurance Information Institute reports (III reports), 359
- Insurance programs and requirements, 884–897
- builder’s risk, 886–887
 - CGL, 885–886
 - E&O insurance, 887–888
 - influence of green features on insurance policies, 892–897
 - professional liability insurance, 889–890
 - standard documents and related issues, 890–892
 - workman’s compensation insurance, 888–889
- Integrated Design Process (IDP), 120–121, 135–139, 136f
- Integrated multidisciplinary project team, 141–142
- Integrated project delivery (IPD), 241, 242f, 769
- sharing intelligent data for sustainable solutions, 241–243
- Intelligent buildings, 461–468, 463f
- Intelligent Energy Management Systems, 461–468. *See also* Heating, ventilating, and air conditioning (HVAC)
- BAS, 461–468
 - intelligent buildings, 461–468, 463f
- Intensive green roofs, 291–293

- Interagency Sustainability Working Group (ISWG), 146
- Interest during construction (IDC), 586
- Interior air quality (IAQ). *See* Indoor air quality (IAQ)
- Interior lighting, 522–525
- Interior nonstructural elements, 315
- Internal Revenue Service (IRS), 813–815
- International Alliance for Interoperability (IAI), 246
- International Code Council (ICC), 443–444
- International Dark-Sky Association (IDA), 744
- International Energy Agency (IEA), 4–6
- International Energy Conservation Code (IECC), 121–122
- International Green Construction Code (IgCC), 112, 164, 356, 424, 443–444, 621, 659, 736
- codes, 116–118, 124–125
- International Organization for Standardization (ISO), 321, 407–408, 745
- ISO 9000 Standard, 224
- International Plumbing Code (IPC), 418–419
- Internet and Internet marketing, 840–851
- importance of website, 841–843
 - pinpoint target audience and determining interests, 847–851
 - converting site visitors to clients, 849–851
 - planning website, 843–845
 - registering domain name, 844
 - setting up website, 844
 - web hosting service, 844–845
 - website components and website content, 845–847
 - website security, 851
- Inverter, 534
- Investment tax credits (ITCs), 18
- Ionization detectors, 561
- IPC. *See* International Plumbing Code (IPC)
- IPD. *See* Integrated project delivery (IPD)
- IRS. *See* Internal Revenue Service (IRS)
- ISO. *See* International Organization for Standardization (ISO)
- ISWG. *See* Interagency Sustainability Working Group (ISWG)
- ITCs. *See* Investment tax credits (ITCs)
- IVI. *See* Inspection & Valuation International, Inc. (IVI)
- J**
- Job Cost Report (JCR), 172. *See also* Certification
- Joint Contracts Tribunal (JCT), 891
- JPEG File Interchange Format (.jpg;.jpeg), 737
- K**
- Keyword density, 851
- Kilowatt hours (kwh), 513
- meter, 536
- L**
- Labeling, 556f, 557
- Labor contract, 762–763
- advantages, 762
 - disadvantages, 762–763
- Landscaping irrigation, 416–417
- Lawrence Berkeley National Laboratory (LBNL), 653
- Lawsuits, 459–460
- LBNL. *See* Lawrence Berkeley National Laboratory (LBNL)
- LCA. *See* Life-cycle assessment (LCA)
- LCCA. *See* Life-cycle cost analysis (LCCA)
- LCCs. *See* Life-cycle costs (LCCs)
- Lead, 364–366
- paint testing, 366
- Leadership in Energy and Environmental Design (LEED), 6–8, 47–48, 55, 92, 130, 350, 432–433, 539, 578, 591f, 662–663, 853–854
- Building Certification Model, 70–71
 - certification, 64
 - contributions, 544–545
 - EA Prerequisites, 447–449
 - Green Building Rating System, 47–48, 59, 63–64
 - Law. *See* New York City's Local Law 86

- LEED-accredited professional and building commissioning expenses, 895
- Minimum Energy Performance and Fundamental Refrigerant Management, 472
- new improvement, 71–73
- Online v3 Rating System, 72–73
- Points Rating System, 67–70
- process, 64–66
- requirements, 540
- third-party certification program, 349–350
- 2009 Rating System, 444–445
- USGBC LEED certification and rating system, 63–73
- V3 Rating systems, 66, 70–71, 444–445
- V4, 64–66
 - MR, 258
 - Rating systems, 444
 - Reference Guide, 507
 - working process, 66–67
- LEED Accredited Professional (LEED AP), 70
- LEED for Existing Buildings: Operations & Maintenance (LEED EBOM), 544
- LEED for New Construction (LEED-NC), 544
- Lender/owner retainage, 192–193
- Lender's preconstruction meeting, 173–177
- Liability-related issues, 740–742, 859–863
 - ADR, 862–863
 - green material and products claims, 860
 - green performance-related claims, 860–862
- Licenses and permits, 832–838
 - business operation license, 835–836
 - occupational licenses, 836
 - other licenses and permits, 836–837
 - signage permit, 836
- Life cycle analyses, 860
- Life-cycle assessment (LCA), 260, 343–344
 - of building materials and products, 346–349
- Life-cycle cost analysis (LCCA), 31, 346, 601–604, 612–613
 - of building materials and products, 347–349
- Life-cycle costs (LCCs), 285, 599–600
 - in Design WinLCCID Program, 618
 - initial/first costs, 601
- Light pollution, 527
- Lighting systems, 465–466, 521–528. *See also* Electrical power systems
 - deficiencies in, 511f
 - emergency lighting systems, 519–521
 - exterior lighting systems, 526–527
 - illumination levels, 522f
 - interior lighting, 522–525
- Limited Liability Company (LLC), 832
- Linoleum, 333–335
- Litigation and liability issues. *See also* Green building (GB)
 - ADR *vs.* traditional litigation, 872–883
 - common defects in building
 - construction, 857f
 - construction-related disputes, 858–859
 - failure, negligence, and standard of care, 863–872
 - procedural issues, 865–872, 866f
 - green building projects, 854–855
 - heavy mold infestation causing by water penetration, 858f
 - increasing litigation, 853–854
 - insurance programs and requirements, 884–897
 - liability-related issues, 859–863
 - state and local governments, 853
- Livable communities and neighborhoods, 127–128
- LL86. *See* Local Law 86 (LL86)
- LLC. *See* Limited Liability Company (LLC)
- Loan disbursements, 186–199
 - changing orders, 189–192
 - DOR/administrator sign off, 198–199
 - General Conditions, 193–197
 - lender/owner retainage, 192–193
 - stored materials funding, 187–189
 - Supplemental Conditions, 198
 - value of work in place, 186–187
- Local Law 86 (LL86), 23–24
- Long-term cost implications of commissioning, 634

- Long-term savings, 424
- Low-emitting materials, 261–313
 adhesives, finishes, and sealants, 263–265
 earthen building materials, 275–277
 flooring systems, 268–274
 paints and coatings, 265–267
 windows, 277–280
- Low-pressure sprinklers, 543
- Low-profile, decorator, and concealed sprinklers, 543
- Low-profile roofs. *See* Extensive green roofs
- Lump sum contract, 753–756
 advantages, 754–755
 disadvantages, 755–756
 with price adjustment, 756
- M**
- M&V. *See* Measurement and Verification (M&V)
- MADA. *See* Multiattribute decision analysis (MADA)
- “Magic wand” solution, 245–246
- Main DC disconnect, 535
- Malqafs, 398–399
- Man-made wood. *See* Engineered lumber
- Marketing company services, 821–822
 time management, 822, 823f
- Masonry wall systems, 452
- Mass Notification systems (MNSs), 568
- Master systems, 704–705, 707–708
- MasterFormat, 712, 715f–720f, 723, 724f–726f
- Material reuse, 313, 315–317
 LEED potential technologies and strategies, 316
 LEED requirements, 316
- Materials and Resources (MR), 66, 258
- Maximum Credible Earthquake (MCE), 908
- Maximum Probable Earthquake (MPE), 908
- MCS. *See* Multiple Chemical Sensitivity (MCS)
- MDF. *See* Medium-density fiberboard (MDF)
- MDI. *See* Methylene diphenyl diisocyanate (MDI)
- Measurement and Verification (M&V), 448–449
- Mechanical, electrical, and plumbing (MEP), 248, 317–318
- Mediation, 874, 877–878
- Medium-density fiberboard (MDF), 298–299, 369–370
- Melamine-formaldehyde resin, 297
- Memorandum of Agreement (MOA), 619
- Memorandum of Understanding (MOU), 7–8, 49, 145–146
- MEP. *See* Mechanical, electrical, and plumbing (MEP)
- MERV. *See* Minimum Efficiency Reporting Value (MERV)
- Meta tags, 851
- Metal, 287
- Metering faucets, 435
- Meters, 515
- Methylene chloride, 264
- Methylene diphenyl diisocyanate (MDI), 297
- Mexico Green Building Council (CMES), 102
- MIC. *See* Microbiologically Influenced Corrosion (MIC)
- Microbiologically Influenced Corrosion (MIC), 544
- Microclimate, 12, 34–35
- Mildew, 373–374
- Minimum Efficiency Reporting Value (MERV), 400, 507–508
- Minimum energy performance, 447
- Minimum Energy Performance and Fundamental Refrigerant Management, 472
- Minimum Program Requirements (MPRs), 64–65
- Ministry of Construction (MoC), 62
- Ministry of Land, Infrastructure, Transport and Tourism (MLIT), 100
- Miscellaneous building elements
 gypsum wall board, 281–282
 siding, 282–284
- Miscellaneous provisions, 685

- Mites, 378–380
- MLIT. *See* Ministry of Land, Infrastructure, Transport and Tourism (MLIT)
- MNSs. *See* Mass Notification systems (MNSs)
- MOA. *See* Memorandum of Agreement (MOA)
- MoC. *See* Ministry of Construction (MoC)
- Mock-ups, 729
- Modular systems. *See* Unitized systems
- Moisture, 611–612
- Mold, 373–374
- Motors, 517–518
- MOU. *See* Memorandum of Understanding (MOU)
- MPRs. *See* Minimum Program Requirements (MPRs)
- MR. *See* Materials and Resources (MR)
- MSW. *See* Municipal solid waste (MSW)
- MUD. *See* Municipal utility district (MUD)
- Multiatribute decision analysis (MADA), 612–613
- Multicriteria intelligent sensor, 466f
- Multiple Chemical Sensitivity (MCS), 359–360
- Municipal solid waste (MSW), 268
- Municipal utility district (MUD), 413
- N**
- N/A criteria. *See* Nonapplicable criteria (N/A criteria)
- NABERS. *See* National Australian Built Environment Rating System (NABERS)
- NAHB. *See* National Association of Home builders (NAHB)
- NAHB RC. *See* NAHB Research Center (NAHB RC)
- NAHB Research Center (NAHB RC), 23–24
- NAHBGreen program, 109
- NASA. *See* National Aeronautics and Space Administration (NASA)
- NASFA. *See* National Association of State Facilities Administrators (NASFA)
- National Aeronautics and Space Administration (NASA), 739
- National Association of Home builders (NAHB), 23–24, 35, 60, 82, 109
point system, 60t
- National Association of State Facilities Administrators (NASFA), 632–633
- National Australian Built Environment Rating System (NABERS), 93–94
- National BIM Standard–United States (NBIMS-US), 231–232
- National Building Code, 113
- National Conference on Building Commissioning (NCBC), 621
- National Electrical Code (NEC), 511, 517
- National Electrical Manufacturers Association (NEMA), 514–515
- National Fenestration Rating Council (NFRC), 279–280, 745
- National Fire Protection Association (NFPA), 511
NFPA 16, 552
- National Fire Protection Code (NFPC), 511
- National Green Building Code, 139–140
- National Green Building Standard (NGBS), 21
- National Institute of Building Sciences (NIBS), 61, 227–228, 409, 451
- National Institute of Standards and Technology (NIST), 68–70, 347, 602, 618
- National Lumber and Building Material Dealers Association (NLBMDA), 343–344
- National Science Foundation (NSF), 745
- National Society of Professional Engineers (NSPE), 801
- Natural materials, 259–261
- Natural Resources Canada (NRCan), 94
- Naval Facilities Engineering Command (NAVFAC), 451
- NBI. *See* New Buildings Institute (NBI)
- NBIMS-US. *See* National BIM Standard–United States (NBIMS-US)
- NCBC. *See* National Conference on Building Commissioning (NCBC)

- NEC. *See* National Electrical Code (NEC)
- Negative impact, 257
- Negligence, 863–872
 - procedural issues, 865–872, 866f
 - document collection, 866–867
 - expert witness, 871–872
 - experts cooperation, 867
 - interviews, 867
 - preliminary assessment, 867–868
 - standard of care and duty to perform, 869–871
- Negotiated contract, 763
- Negotiation, 878
- NEMA. *See* National Electrical Manufacturers Association (NEMA)
- Net Present Value (NPV), 594–595, 609
 - calculations, 613–614
- Net Savings (NS), 603–604
- Net Zero Energy Buildings (NZEB), 443–444
- New American Home (2016), 109
- New Buildings Institute (NBI), 610
- New York City
 - Green Building Law, 23–24
 - Local Law 86, 25–26
- New Zealand Green Building Council (NZGBC), 103
- NFPA. *See* National Fire Protection Association (NFPA)
- NFPC. *See* National Fire Protection Code (NFPC)
- NFRC. *See* National Fenestration Rating Council (NFRC)
- NGBS. *See* National Green Building Standard (NGBS)
- NIBS. *See* National Institute of Building Sciences (NIBS)
- NIST. *See* National Institute of Standards and Technology (NIST)
- Nitrogen dioxide (NO₂), 367–368
- NLBMDA. *See* National Lumber and Building Material Dealers Association (NLBMDA)
- Noise pollution, 384–386
 - noise, 384–385
 - impact of noise, 385–386
 - sources of noise, 386
- “Nominal” values of volts, 511–512
- Nonapplicable criteria
 - (N/A criteria), 88
- Nonbinding arbitration, 874–876
- Nonmonetary benefits, 612–613
- Nonrestrictive specification, 710
- Norway, BIM, 253–254
- Notice of Commencement, 178–180
- Notice to Proceed, 165, 179f–180f, 180–181, 191
- Notification Systems, 568–570
- NPV. *See* Net Present Value (NPV)
- NRCan. *See* Natural Resources Canada (NRCan)
- NS. *See* Net Savings (NS)
- NSF. *See* National Science Foundation (NSF)
- NSPE. *See* National Society of Professional Engineers (NSPE)
- Nylon, 268–269
- NZEB. *See* Net Zero Energy Buildings (NZEB)
- NZGBC. *See* New Zealand Green Building Council (NZGBC)
- O**
- O&M. *See* Operations & Maintenance (O&M)
- Occupancy sensors, 465
- Occupational licenses, 836
- OEE. *See* Office of Energy Efficiency (OEE)
- OEHHA. *See* Office of Environmental Health Hazard Assessment (OEHHA)
- Office of Energy Efficiency (OEE), 94
- Office of Environmental Health Hazard Assessment (OEHHA), 746
- Office of Management and Budget (OMB), 615
- OMB. *See* Office of Management and Budget (OMB)
- On-grid intertied PV systems. *See* Grid-Tied Solar System
- On-site renewable energy, 448
- On-site solar energy collection system, 501–503

- Open specification, 710–712. *See also*
 Closed specifications
 descriptive, 710
 performance specifications, 711
 proprietary specifications, 711–712
 reference standard, 710–711
- Operation, repair, and maintenance costs, 610
- Operational energy, 608–609, 608f, 610t
- Operations & Maintenance (O&M), 621
- OPR. *See* Owner's Project Requirements (OPR)
- Optical smoke detectors, 560
- Optimum-value engineering (OVE), 300
- Organic contaminants, 368–372
 HCHO, 369–370
 hydrocarbons, 370–371
 PCBs, 370
 pesticides, 371–372
- Oriented strand board (OSB), 297–298
- OSB. *See* Oriented strand board (OSB)
- OVE. *See* Optimum-value engineering (OVE)
- Overhead
 expenses, 690
 margins, 694
- Owner responsibilities, 682
- Owner/contractor agreement. *See* A-Series (Owner/contractor agreements); A-Series (Owner/Contractor Agreements)
- Owner's contingency, 687
- Owner's Project Requirements (OPR), 447, 621
- Oxygen (O₂), 366
- Ozone-depleting gases, 351
- P**
- Packaged systems, 491–492
- Packaged terminal air conditioners (PTACs), 123
- PageFormat, 727–728
- Paints, 265–267
- PAM. *See* Pertubuhan Akitek Malaysia (PAM)
- Panelboards, 515
- PAR. *See* Project Analysis Report (PAR)
- Partial waiver of liens, 915f
- Particulate organic materials (POMs), 368
- Partnership for Advancing Technology in Housing (PATH), 303, 611–612
- Passive solar
 buildings, 538–539
 energy systems, 538–540
- Passive solar buildings, 538–539
- Passive solar energy systems, 538–540
- PATH. *See* Partnership for Advancing Technology in Housing (PATH)
- Payback measures, 603–604
- Payment bonds, 207–208
- Payment Requisition, 168–169
- PCA research, 931
- PCBs. *See* Polychlorinated Biphenyls (PCBs)
- PCR project files, 932–933
- PECI. *See* Portland Energy Conservation, Inc. (PECI)
- PEFC. *See* Programme for Endorsement of Forest Certification (PEFC)
- PEI. *See* Porcelain Enamel Institute (PEI)
- Perfluorocarbons (PFCs), 407
- Performance bonds, 207–208
- Performance specifications, 710–712
- Pertubuhan Akitek Malaysia (PAM), 101–102
- Pesticides, 368–372
- PF. *See* Phenol formaldehyde (PF)
- PFCs. *See* Perfluorocarbons (PFCs)
- PFOA, 407
- Phenol formaldehyde (PF), 297
- Phenolic, 297
- Photo descriptions
 exhibits, 931–932
 PCA research, 931
 PCR project files, 932–933
- Photo documentation, 182–186
- Photosynthesis, 366–367
- Photovoltaic systems (PV systems), 530, 533
- Photovoltaics (PV), 609
 systems, 530, 533
- Phthalates, 406
- Pinnacle West Capital Corp., 500–501
- Pivotal tool, 661

- Planning commissioning process, 634–639
 documentation, 636–639
 Plans and document review, 905–906
 Plastic, 259–260
 PM. *See* Project manager (PM)
 PMI. *See* Project Management Institute (PMI)
 Pollutants, 56, 58
 Polychlorinated Biphenyls (PCBs), 370
 Polystyrene insulation (PS insulation), 286
 Polyurethane resin (PU resin), 297
 Polyvinyl chloride (PVC), 268–270, 405
 POMs. *See* Particulate organic materials (POMs)
 Porcelain Enamel Institute (PEI),
 272–273
 Portable Network Graphics (.png), 737
 Portland Energy Conservation, Inc. (PECI),
 632–633
 Pos. *See* Purchase Orders (Pos)
 Postconsumer content, 321
 Postindustrial, 321
 Postoccupancy testing, 657–659
 Potable water, 415–416
 calculation for sewage conveyance, 436
 reducing demand, 419–420
 Practical Building Rating System, 73
 Preaction systems, 549–551
 Preconstruction conference and notice to
 proceed, 682
 Preconstruction documents, 177–181
 Preconsumer recycled content, 321
 Prerequisites, 258
 Prescriptive specifications,
 709–710
 Present value (PV), 599–600
 analysis, 613–616
 Pressure-treated lumber, 294
 Primary air, 494
 Principles of green design, 116–128
 commissioning operation and
 maintenance, 126–127
 energy efficiency, 121–123
 holistic approach, 119
 indoor environmental quality and safety,
 125–126
 integrated design, 120–121
 livable communities and neighborhoods,
 127–128
 materials and resources, 124–125
 native and drought-resistant planting, 120f
 site selection, 121
 state-of-the-art building technologies, 118
 waste management issues, 126
 water efficiency and conservation, 124
 Product
 requirements, 726–727
 specification, 711–712, 727f
 Professional ethics, 881–883
 Professional liability insurance, 889–890
 Program Management, 153–154
 Program management documents (800
 Series), 800
 Programme for Endorsement of Forest
 Certification (PEFC), 745
 Progress Payments, 709
 Project
 budget estimate, 669
 buyout, 675–681, 675f, 680f
 checklist, 780
 contingency, 688
 development, 632
 evaluation and analysis, 164–165
 management, 72, 79, 152–153
 management contract, 761–762
 advantages, 761
 disadvantages, 761–762
 manual, 712–722
 requirements, 722
 phases, 634–635
 progress meetings, 204
 schedules, 203–204
 stakeholders, 240
 Project Analysis Report (PAR), 165
 Project budget estimate, 669
 Project buyout, 675–681, 675f, 680f
 Project checklist, 780
 Project closeout, 210–224
 architect/administrator
 Certificate of Substantial Completion,
 212–214
 Certified Copy of Final Punchlist, 215
 as-built drawings, 211–212
 ASI, 219

- CO, 215–216
 - commissioning and warranties, 216–218
 - Contractor's Certificate of Compliance, 212
 - final waivers of lien, 216, 217f–218f
 - FOIL, 223–224
 - Shop Drawing submittal and review
 - procedure, 220–223
 - time extensions, 219–220
 - Project contingency, 688
 - Project cost analysis
 - budget development, 669–672, 669f, 673f–674f
 - computer-aided cost estimation software, 661–662
 - construction cost, 664
 - contingencies and allowances, 686–693
 - cost breakdown, 666f–668f
 - general conditions, 681–686
 - green project cost management, 694–701, 695f
 - LEED, 662–663
 - project buyout and bid shopping, 675–681, 675f, 680f
 - supplemental conditions, 686
 - Project development, 632
 - Project evaluation and analysis, 164–165
 - Project Management, 72, 79, 152–153
 - advantages, 761
 - contract, 761–762
 - disadvantages, 761–762
 - Project Management Institute (PMI), 163
 - Project manager (PM), 671, 694, 697f
 - Project manual, 712–722
 - requirements, 722
 - Project phases, 634–635
 - Project progress meetings, 204
 - Project Schedules, 203–204
 - Project stakeholders, 240
 - Project Status Report (PSR), 172, 909. *See also* Certification
 - ABC Project No.V5221, 909
 - actual construction costs *vs.* direct cost budget, 911
 - As-Built survey, 913
 - certified values of work-in-place, 911
 - Change Orders, 912
 - CO, 912
 - construction permits, 912
 - construction schedule, 913
 - and schedule of values, 203–204
 - daily work log, 202–203
 - draw applications—documents
 - requirement, 199
 - outstanding documentation, 913
 - payment and performance bonds, 207–208
 - permits and approvals, 209–210
 - preparation, 199–210
 - project progress meetings, 204
 - quality of construction, 912
 - requisition retainage, 912
 - RFI and other logs, 208–209
 - status of construction, 910–911
 - stored material
 - funding and documentation, 204–205
 - statement, 206f
 - subcontracts and purchase orders, 205
 - Template, 722
 - testing reports, 200–202
 - waivers of lien, 199–200, 912
 - Projected beam detectors, 560–561
 - Projectmates, 661
 - Proprietary specifications, 710–712
 - PS insulation. *See* Polystyrene insulation (PS insulation)
 - PSR. *See* Project Status Report (PSR)
 - PTACs. *See* Packaged terminal air conditioners (PTACs)
 - PU resin. *See* Polyurethane resin (PU resin)
 - Public-private partnerships projects (3P projects), 889
 - Punchlist, 210, 215
 - Purchase Orders (Pos), 680
 - PV. *See* Photovoltaics (PV); Present value (PV)
 - PV systems. *See* Photovoltaic systems (PV systems)
 - PVC. *See* Polyvinyl chloride (PVC)
- ## Q
- Q fever, 376
 - Quality assurance, 224–225, 626, 729
 - Quality control, 224–225

- Quality of construction, 912
Quercus suber, 330
 Query fever. *See* Q fever
- R**
- “R-2000” program, 94
 R-values, 278–279
 impact full frame R-value of, 280
 R&D. *See* Research and development (R&D)
 Radiant heating, 476
 Radon, 362–364
 mitigation, 363
 testing methods, 363–364
 Rainwater collection, 418
 Rainwater harvesting, local requirements for, 439–440
 Rapidly renewable materials, 327–339
 bamboo, 327–330
 cork, 330–331
 insulation, 331–333
 Linoleum, 333–335
 straw-bale construction, 335–338
 wheat board, 338–339
 Rate of return, 593–594
 Rats, 377–378
 RC building materials. *See* Recyclable building materials (RC building materials)
 RCCs. *See* Reverse cycle chillers (RCCs)
 RCPs. *See* Recycled-content products (RCPs)
 RCx. *See* Retrocommissioning (RCx)
 Receptacles, 517
 Reclaimed water, 419
 Recommission (ReCx), 654–655, 655f
 management manual, 638
 Record drawings. *See* As-Built drawings
 RECs. *See* Renewable Energy Certificates (RECs)
 ReCx. *See* Recommission (ReCx)
 Recyclability, 322
 Recyclable building materials (RC building materials), 324, 325t
 storage and collection of, 261
 Recycled content, 321
 Recycled materials, 320–324
 Recycled-content products (RCPs), 322
 Recycling, 7–8
 Redline corrections, 212
 Reference standard specification, 710–711
 Referenced standards, 742–746
 Refrigerants, 471–472
 Regional materials, 325–327
 LEED requirement, 325–327
 Regional Priority (RP), 66
 Registers, 499–500
 Reinforced concrete, 309
 Relative humidity level (RH level), 372
 Renewable Energy Certificates (RECs), 449
 Request for Information (RFI), 788, 800
 Log, 722
 and other logs, 208–209
 Requests for proposals (RFPs), 233, 782
 Requests for Quotes (RFQs), 680
 Requisition format, 167–173
 Research and development (R&D), 248
 Residential sprinklers, 543
 Resilient Floor Covering Institute (RFCI), 270, 745
 Resorcinol, 297
 Restrictive specification. *See* Closed specifications
 Retainage, 192–193
 requisition, 912
 Retarding admixtures, 310
 Retention ponds, 438–441
 Retrocommissioning (RCx), 646, 653–656
 Return on investment (ROI), 340–341, 575
 Reusable (RU), 324, 325t
 Reverse cycle chillers (RCCs), 480–481
 RFCI. *See* Resilient Floor Covering Institute (RFCI)
 RFI. *See* Request for Information (RFI)
 RFPs. *See* Requests for proposals (RFPs)
 RFQs. *See* Requests for Quotes (RFQs)
 RH level. *See* Relative humidity level (RH level)
 Risk allowance(s), 694, 696
 management, 696–698
 Risk reducing, 595–596
 Rodent, 377–381
 rats, 377–378

- ROI. *See* Return on investment (ROI)
- Roofing, 284–293
choosing roofing materials, 286–291
extensive and intensive green roofs,
291–293
- RP. *See* Regional Priority (RP)
- RU. *See* Reusable (RU)
- S**
- Salvaged materials, 316
- Sample pay approval letter
acoustical testing, 907
building condition review, 906–907
engagement letter, 901
plans and document review, 905–906
seismic risk analysis, 907–908
- Savings-to-Investment Ratio (SIR), 603–604
- SBCI. *See* Sustainable Buildings and
Climate Initiative Member (SBCI)
- SBIC. *See* Sustainable Buildings Industry
Council (SBIC)
- SBS. *See* Sick building syndrome (SBS)
- SCA. *See* School Construction Authority
(SCA)
- SCAQMD. *See* South Coast Air Quality
Management District (SCAQMD)
- School Construction Authority (SCA),
23–24
- Scientific Certification Systems (SCS), 745
- Scope of work, 755–756
- Scroll compressor, 484
- SCS. *See* Green Seal, Scientific Certifi-
cation Systems (SCS); Scientific
Certification Systems (SCS)
- SDI. *See* State Disability insurance (SDI)
- Sealants, 263–265
- Seasonal Energy Efficiency Ratio (SEER),
483–484
- Secondary water, 494
- SectionFormat, 726–727
- Securitization, 921
- SEER. *See* Seasonal Energy Efficiency
Ratio (SEER)
- Seismic risk analysis, 907–908
- Self introductions, 828–831
correspondence, 828
formal meetings, 829–831
general meetings, 828–829
informal meetings, 829
- Semiextensive green roof, 291
- Semiintensive green roof, 291
- Semivolatile organic compounds (SVOCs),
368
- Sensitivity analysis, 616–617
- Service connections, 513–514
- Service drop, 508–509, 514
- Service outlets, 517
- SFI. *See* Sustainable Forestry Initiative (SFI)
- Sheathing, 282–283, 297–298
- SHGC. *See* Solar heat-gain coefficient
(SHGC)
- Shop drawing, 787
- Shop Drawing submittal and review
procedure, 220–223
- Showerheads, 434–436
flow-optimized showerheads, 435–436
- Sick building syndrome (SBS), 4, 125–126,
353, 356–357, 577–578, 596, 654,
856–857
- Siding, 282–284, 455–457
- Siemes MXL fire alarm control panel, 569f
- Signage permit, 836
- Simple Payback (SPB), 603–604
- Singapore, BIM, 256
- Single package vertical air conditioners
(SPVAC), 123
- Single package vertical heat pumps
(SPVHP), 123
- Single purpose entity agreement (SPE
agreement), 777
- SIPs. *See* Structural insulated panels (SIPs)
- SIR. *See* Savings-to-Investment Ratio (SIR)
- SIRIM. *See* Standards and Industrial
Research Institute of Malaysia
(SIRIM)
- Site selection, 121
- Site visits and observations, 173–186
agenda for preconstruction kick-off
meeting, 174f–176f
lender's preconstruction meeting,
173–177
photo documentation, 182–186
preconstruction documents, 177–181
walk site/project, 181–182

- Skidmore, Owings & Merrill (SOM), 229
- Skylights, 458
- Smart grid systems, 18
- “Smart Growth” design, 135
- Smart meters, 18
- Smart/intelligent buildings, high performance and, 128–131
- Smoke alarm. *See* Smoke detector
- Smoke detection systems, 558–561
- Smoke detector, 559, 559f
- Soft costs, 670, 690
- “Softwood”, 293
- Solar electric panels, 533
- Solar energy, 115
- Solar energy systems, 530–540. *See also* Electrical power systems
solar electric system basics, 532–536
solar options, 530–532
solar power LED street lighting, 531f
solar thermal collector works, 533f
types, 536–540
- Solar heat-gain coefficient (SHGC), 280
- Solar photovoltaics, 530–532
- Solar systems, 485, 485f
- Solar thermal collectors, 484–485
- Solar water-heating collectors, 485
- SOM. *See* Skidmore, Owings & Merrill (SOM)
- South Coast Air Quality Management District (SCAQMD), 263, 746
- SPB. *See* Simple Payback (SPB)
- SPE agreement. *See* Single purpose entity agreement (SPE agreement)
- Special sprinklers, 543
- Specification section format, 726–733
execution, 732–733
general, 728–731
products, 731–732
- Specifications–Kept–Intact System (SpecsIntact System), 739
- SpecLink images, 737, 738f
- SpecsIntact System. *See* Specifications–Kept–Intact System (SpecsIntact System)
- Split system, 489–491, 491f
- Sprayed PU foam, 333
- Sprinkler systems, 544–554
automatic sprinkler systems, 545–548
deluge and preaction systems, 549–551
dry pipe systems, 548–549
fire hose and standpipe systems, 553–554
foam–water sprinkler systems, 551–552
water mist systems, 551
- SPVAC. *See* Single package vertical air conditioners (SPVAC)
- SPVHP. *See* Single package vertical heat pumps (SPVHP)
- SR motors. *See* Stepper/switched reluctance motors (SR motors)
- SSs. *See* Sustainable Sites (SSs)
- Stand-Alone Grid-Tied Solar System with Battery Backup, 537
- Stand-Alone Off-Grid Solar-Electric System without energy storage, 538
- Standards and Industrial Research Institute of Malaysia (SIRIM), 101–102
- Standpipe systems, 553–554
- Start-up costs, 812–819, 814f
accounting and bookkeeping, 818–819
decorating, 816
employees and required forms, 813–815
expense report, 816–818, 817f
furniture, 815
internet service, 816
miscellaneous issues, 819
office equipment, 815
suppliers, 816
- State Disability insurance (SDI), 838
- State Unemployment taxes (SUE taxes), 838
- Steam heating systems, 479–480
- Steel, 279
- “Step down” transformers, 519–520
- “Step up” transformers, 519–520
- Stepper/switched reluctance motors (SR motors), 518
- Stewardship, 2, 22, 32–33
- Stick systems, 455, 457f–458f
- “Stipulated Sum” contract, 753
- Stone veneer with through-wall flashing, 452–453, 453f
- Stone wall systems, 452–453
- Stored materials funding, 187–189
and documentation, 204–205

Stormwater runoff, 438
 Straw-bale construction, 335–338
 Structural insulated panels (SIPs), 304
 Subcontracting documents (700 Series), 798
 Subcontracts and purchase orders, 205
 Substantial completion, 664–668
 clearance of site, 685
 SUE taxes. *See* State Unemployment taxes (SUE taxes)
 Sulfur dioxide (SO₂), 366
 Sunlight, 612
 Supplemental Conditions, 198, 686
 Suppression sprinklers, 543
 Sustainable approach, 450
 Sustainable building. *See* Green building
 Sustainable Buildings and Climate Initiative Member (SBCI), 95
 Sustainable Buildings Industry Council (SBIC), 618
 Sustainable Forestry Initiative (SFI), 88–89, 344, 745
 Sustainable Sites (SSs), 66
 SVOCs. *See* Semivolatile organic compounds (SVOCs)
 Switchboards, 514–515
 Switches, 517–518
 Switchgear, 514–515
 Synthetic carpeting, 268–269
 Synthetic gypsum-board, 281
 Synthetic materials, 259–261
 System approaches, 422–425
 construction waste management, 424–425
 gray water demonstrations, 423–424
 long-term savings, 424
 System meter, 535
 Systems manual, 641
 Systems performance monitoring, 656–657

T

TAB effort. *See* Test, adjust, and balance effort (TAB effort)
 Tax
 benefits, 604–607
 credits, 604–605, 607
 for consumers, 540

Tax Deductions, 839–840
 and incentives, 16–19
 Tax identification number (TIN), 834
 Tax Incentives Assistance Project (TIAP), 18–19
 Taxes, 838–840
 TBCx approach. *See* Total building commissioning approach (TBCx approach)
 TBCxP. *See* Total Building Commissioning Process (TBCxP)
 Temporary COs (TCOs), 209
 Tenant, improved, 590–591
 TERI. *See* The Energy and Resources Institute (TERI)
 Termites, 381
 Tertiary treatment, 419–420
 Test, adjust, and balance effort (TAB effort), 640
 Testing reports, 200–202
 The Energy and Resources Institute (TERI), 97
 Thermal breaks, 279
 Thermal comfort, 383–384
 Thermal relays, 518
 Thermoplastic olefin (TPO), 286
 Thermostats, 500–501
 Third-party certification, 349–351
 3D
 modeling, 228
 modeling program, 137
 visualization, 235
 3P projects. *See* Public–private partnerships projects (3P projects)
 Three-phase 416Y/230 system, 509
 Three-phase AC induction motor, 518
 TIAP. *See* Tax Incentives Assistance Project (TIAP)
 Time extensions, 219–220
 Time management, 822, 823f
 TIN. *See* Tax identification number (TIN)
 Toilet, 428–434
 composting toilets, 430–432, 431f
 dual flush toilets, 429–430
 HETs, 428–429
 Total building commissioning approach (TBCx approach), 624

- Total Building Commissioning Process (TBCxP), 639
- Total project cost (TPC), 664, 666f–668f
- Toxic building materials, 405–407
 - heavy metals, 406
 - HFRs, 407
 - PFCs, 407
 - phthalates, 406
 - PVC, 405
 - VOCs, 405–406
- Toxic lifecycle, 271–272
- Toxic materials, 351
- TPC. *See* Total project cost (TPC)
- TPO. *See* Thermoplastic olefin (TPO)
- Traditional “power combustion” furnaces, 475–476
- Traditional green design-bid-build project delivery, 148–150
- Traditional litigation, 872–883
- Transfer of rights of recovery. *See* Waiver of subrogation
- Transformers, 519–521, 521f
- Triplex cable, 509
- 20–20 CAP studio, 739
- 2018 IgCC Development, 112
- Two-pipe arrangement, 478–479
- U**
- U-factor, 278–280
- U-values, 445–446
- U.S. Department of Agriculture (USDA), 343–344, 746
- U.S. Department of Energy (DOE), 37, 43, 128
 - building operations, 443–444
- U.S. EPA. *See* United States Environmental Protection Agency (U.S. EPA)
- U.S. Green Building Council (USGBC), 2, 9, 82, 92, 257, 446, 573, 578, 631
 - LEED certification and rating system, 63–73
 - LEED Building Certification Model, 70–71
 - LEED Points Rating System, 67–70
 - LEED process, 64–66
 - LEED working process, 66–67
 - new improvement, 71–73
- UCC. *See* Uniform Commercial Code (UCC)
- UESC. *See* Utility Energy Services Contract (UESC)
- UF. *See* Urea-formaldehyde (UF)
- UF foam insulation (UFFI), 369–370
- UK Green Building Council (UK-GBC), 106
- UL. *See* Underwriters Laboratories (UL)
- ULFTs. *See* Ultra-Low Flush Toilets (ULFTs)
- ULI. *See* Urban Land Institute (ULI)
- Ultra-Low Flush Toilets (ULFTs), 429
- Ultraviolet light (UV light), 612
- Unassisted negotiation, 878–879
- Underwriters Laboratories (UL), 562–563, 746
- Uniform Building Cod (UBC), 908
- Uniform Commercial Code (UCC), 770
- Uniform Plumbing Code (UPC), 418–419
- Uniform resource locator (URL), 843
- Unit price contract, 758–761, 760f
 - advantages, 759–761
 - disadvantages, 761
- United Kingdom, BIM, 251–252
- United States
 - adopting commercial energy codes, 446
 - building construction values in, 445–446
 - green features on insurance policies in, 892–897
- United States Energy Independence and Security Act, 128–129
- United States Environmental Protection Agency (U.S. EPA), 319–320
- Unitized systems, 455, 456f
- Universal motor, 518
- UPC. *See* Uniform Plumbing Code (UPC)
- Urban Land Institute (ULI), 590–591
- Urea-formaldehyde (UF), 369
 - resin, 297
- Urea-methanal. *See* Formaldehyde (HCHO)
- Urinal types, 428–434
 - HEUs, 432
 - water-free urinals, 432–434, 433f
- URL. *See* Uniform resource locator (URL)

USDA. *See* U.S. Department of Agriculture (USDA)
 USGBC. *See* U.S. Green Building Council (USGBC)
 Utility Energy Services Contract (UESC), 612, 616
 UV light. *See* Ultraviolet light (UV light)

V

Value engineering, 603
 Vapor compression refrigeration, 487
 Variable Volume Air-Handling Unit (VAV), 466–467
 hybrid systems, 467
 VAV. *See* Variable Volume Air-Handling Unit (VAV)
 VCM. *See* Vinyl chloride monomer (VCM)
 VCT. *See* Vinyl composition tile (VCT)
 VDC. *See* Virtual Design and Construction (VDC)
 Vegetated green roofs, 287
 Ventilation, 398–404, 486, 589–590. *See also*
 Air conditioning systems; Heating systems
 air purification, 400–401
 amount of, 401
 and ductwork, 399
 improvements, 402–404
 air cleaners, 403
 ventilation systems, 403–404
 rate procedure, 356
 types of wind catchers, 398f
 Very Volatile organic compounds (VVOCs), 368
 Viewpoint Construction Software, 661
 Vinyl chloride, 271–272
 Vinyl chloride monomer (VCM), 272
 Vinyl composition tile (VCT), 271
 Vinyl tile, 334–335
 Virtual Design and Construction (VDC), 245
 Virtual model, 227–228
 Viruses, 375–377
 Visible-light transmittance (VLT), 280
 Vitocal 350A-G air/water heat pump, 481f
 VLT. *See* Visible-light transmittance (VLT)

VOC. *See* Volatile organic compound (VOC) *voir dire*, 881
 Volatile organic compound (VOC), 4, 125–126, 128, 262, 356, 405–406
 Voltage (V or Volts), 511–513
 VVOCs. *See* Very Volatile organic compounds (VVOCs)

W

WADI. *See* Wuhan Architectural Design Institute (WADI)
 “Waiver of subrogation”, 897
 Waivers of lien, 199–200, 216, 217f–218f, 917f
 partial, 201f, 915f
 Walk site/project, 181–182
 Walk-through, 658
 Warm air heating systems, 476–478
 Warranty phase, 642, 656–659
 deferred seasonal testing, 657
 postoccupancy testing, 657–659
 relevant resources, codes, and standards,, 659
 systems performance monitoring, 656–657
 Waste management, 73, 126
 Wastewater strategy, 415–425
 innovative wastewater technologies, 419–421, 421f
 reclaimed water *vs.*, gray water systems, 419
 system approaches, 422–425
 water use reduction, 421–422
 Wastewater treatment
 local requirements for, 439–440
 systems, 418
 Water, 493–494
 costs, 608–609, 608f, 610t
 extinguishers, 557
 fixtures, 425–438
 baseline water consumption
 calculations, 436–438
 comparison of plumbing fixture
 water-flow rates, 426t
 faucets and showerheads, 434–436
 National Green Building and Codes, 427t
 toilet and urinal types, 428–434

- Water (*Continued*)
- mist systems, 551
 - reducing admixtures, 310
 - reducing strategy, 425–438
 - baseline water consumption
 - calculations, 436–438
 - comparison of plumbing fixture
 - water-flow rates, 426t
 - faucets and showerheads, 434–436
 - National Green Building and Codes, 427t
 - toilet and urinal types, 428–434
 - reuse/recycling, 415–425
 - innovative wastewater technologies, 419–421, 421f
 - reclaimed water *vs.*, gray water systems, 419
 - system approaches, 422–425
 - water use reduction, 421–422
 - use reduction, 421–422
 - water-cooled chillers, 503
 - water-free urinals, 432–434, 433f
 - water-heating collectors, 484–485
- Water efficiency (WE), 66, 413
- bioswales, 438–441, 440f
 - and conservation, 124
 - detention ponds, 438–441
 - reducing water strategy, 425–438
 - retention ponds, 438–441
 - systems, 438–441
 - wastewater strategy, 415–425
 - water conservation, 414–415
 - water fixtures, 425–438
 - water reuse/recycling, 415–425
- Water source heat pump. *See* Geothermal heat pumps (GHPs)
- Watson, Rob, 444
- Wattage (W or Watts), 511–513
- WBCSD. *See* World Business Council on Sustainable Development (WBCSD)
- WBDG. *See* Whole Building Design Guide (WBDG); World Building Design Guide (WBDG)
- WGBC. *See* World Green Building Council (WGBC)
- WC taxes. *See* Workmen's Compensation taxes (WC taxes)
- WCED. *See* World Commission on Environment and Development (WCED)
- WE. *See* Water efficiency (WE)
- Weatherboard. *See* Siding
- Weatherboarding, 282–283
- Weatherproofing, 459–460
 - water penetration contributing to mold growth, 460f
- Web address, 844
- Web crawler, 851
- Web hosting service, 844–845
- Web-based CSI format, 707–708
- Website(s)
 - components, 845–847
 - adding new content, 847
 - basic website content, 845–847, 848f
 - content, 845–847
 - adding new content, 847
 - basics, 845–847, 848f
 - importance, 841–843
 - setting up, 844
- Weighted Average Cost of Debt. *See* Cost of Debt
- Wet pipe sprinkler systems, 547–548, 548f
- Wet-type transformers, 520
- Wheat board, 338–339
- Whole Building Design Guide (WBDG), 7–8, 61, 454–455, 625
- Window air conditioning units, 487–488, 488f
- Windows, 277–280, 458
- Windows bitmap (.bmp), 737
- Windows metafile (.wmf), 737
- Wiring, 535
- Wood, 293–309
 - concrete, 309–313
 - framing, 300–309
 - types, 293–300
- Wood siding, 284
- Wool carpets, 269
- Workman's compensation insurance, 888–889
- Workmen's Compensation taxes (WC taxes), 838

- World Building Design Guide (WBDG),
141
- World Business Council on Sustainable
Development (WBCSD), 4–6, 600
- World Commission on Environment and
Development (WCED), 27, 56
- World Green Building Council (WGBC),
95
- World Green Building Council
(WorldGBC), 49–50
- Worldwide usage of BIM, 250–256
- China, 255–256
 - Denmark, 254–255
 - Finland, 253
 - France, 252
 - Germany, 252–253
 - Hong Kong, 255
 - Norway, 253–254
 - Singapore, 256
 - United Kingdom, 251–252
- Write-Offs, 839–840
- Wuhan Architectural Design Institute
(WADI), 255–256
- X**
- X-ray Fluorescent lead-in-paint analyzer
(XRF), 366
- Xeriscaping, 418
- XYZ National Bank (XYZB), 921
- Z**
- Zoning systems, 501