

Honeywell

ENGINEERING MANUAL of
**AUTOMATIC
CONTROL** for
COMMERCIAL BUILDINGS
SI Edition



HEATING

VENTILATING

AIR CONDITIONING

Copyright 1989, 1995 and 1997 by Honeywell Inc.

Copyright 1989, 1995, and 1997 by Honeywell Inc.

All rights reserved. This manual or portions thereof may not be reproduced
in any form without permission of Honeywell Inc.

Library of Congress Catalog Card Number: 97-77856

Home and Building Control

Honeywell Inc.
Honeywell Plaza
P.O. Box 524
Minneapolis MN 55408-0524

Honeywell Latin American Region

480 Sawgrass Corporate Parkway
Suite 200
Sunrise FL 33325

Home and Building Control

Honeywell Limited-Honeywell Limitée
155 Gordon Baker Road
North York, Ontario
M2H 3N7

Honeywell Europe S.A.

3 Avenue du Bourget
1140 Brussels
Belgium

Honeywell Asia Pacific Inc.

Room 3213-3225
Sun Hung Kai Centre
No. 30 Harbour Road
Wanchai
Hong Kong

Honeywell

FOREWORD

The Minneapolis Honeywell Regulator Company published the first edition of the Engineering Manual of Automatic Control in 1934. The manual quickly became the standard textbook for the commercial building controls industry. Subsequent editions have enjoyed even greater success in colleges, universities, and contractor and consulting engineering offices throughout the world.

Since the original 1934 edition, the building control industry has experienced dramatic change and made tremendous advances in equipment, system design, and application. In this edition, microprocessor controls are shown in most of the control applications rather than pneumatic, electric, or electronic to reflect the trends in industry today. Consideration of configuration, functionality, and integration plays a significant role in the design of building control systems.

Through the years Honeywell has been dedicated to assisting consulting engineers and architects in the application of automatic controls to heating, ventilating, and air conditioning systems. This manual is an outgrowth of that dedication. Our end user customers, the building owners and operators, will ultimately benefit from the efficiently designed systems resulting from the contents of this manual.

All of this manual's original sections have been updated and enhanced to include the latest developments in control technology and use the International System of Units (SI). A new section has been added on indoor air quality and information on district heating has been added to the Chiller, Boiler, and Distribution System Control Applications Section.

This third SI edition of the Engineering Manual of Automatic Control is our contribution to ensure that we continue to satisfy our customer's requirements. The contributions and encouragement received from previous users are gratefully acknowledged. Further suggestions will be most welcome.

Minneapolis, Minnesota
December, 1997



KEVIN GILLIGAN
President, H&BC Solutions and Services

PREFACE

The purpose of this manual is to provide the reader with a fundamental understanding of controls and how they are applied to the many parts of heating, ventilating, and air conditioning systems in commercial buildings.

Many aspects of control are presented including air handling units, terminal units, chillers, boilers, building airflow, water and steam distribution systems, smoke management, and indoor air quality. Control fundamentals, theory, and types of controls provide background for application of controls to heating, ventilating, and air conditioning systems. Discussions of pneumatic, electric, electronic, and digital controls illustrate that applications may use one or more of several different control methods. Engineering data such as equipment sizing, use of psychrometric charts, and conversion formulas supplement and support the control information. To enhance understanding, definitions of terms are provided within individual sections.

Building management systems have evolved into a major consideration for the control engineer when evaluating a total heating, ventilating, and air conditioning system design. In response to this consideration, the basics of building management systems configuration are presented.

The control recommendations in this manual are general in nature and are not the basis for any specific job or installation. Control systems are furnished according to the plans and specifications prepared by the control engineer. In many instances there is more than one control solution. Professional expertise and judgment are required for the design of a control system. This manual is not a substitute for such expertise and judgment. Always consult a licensed engineer for advice on designing control systems.

It is hoped that the scope of information in this manual will provide the readers with the tools to expand their knowledge base and help develop sound approaches to automatic control.



ENGINEERING MANUAL of AUTOMATIC CONTROL

CONTENTS

Foreward	iii
Preface	v
Control System Fundamentals	1
Control Fundamentals	3
Introduction	5
Definitions	5
HVAC System Characteristics	8
Control System Characteristics	15
Control System Components	30
Characteristics and Attributes of Control Methods	35
Psychrometric Chart Fundamentals	37
Introduction	38
Definitions	38
Description of the Psychrometric Chart	39
The Abridged Psychrometric Chart	40
Examples of Air Mixing Process	42
Air Conditioning Processes	43
Humidifying Process	44
Process Summary	53
ASHRAE Psychrometric Charts	53
Pneumatic Control Fundamentals	57
Introduction	59
Definitions	59
Abbreviations	60
Symbols	61
Basic Pneumatic Control System	61
Air Supply Equipment	65
Thermostats	69
Controllers	70
Sensor-Controller Systems	72
Actuators and Final Control Elements	74
Relays and Switches	77
Pneumatic Control Combinations	84
Pneumatic Centralization	89
Pneumatic Control System Example	90
Electric Control Fundamentals	95
Introduction	97
Definitions	97
How Electric Control Circuits are Classified	99
Series 40 Control Circuits	100
Series 80 Control Circuits	102
Series 60 Two-Position Control Circuits	103
Series 60 Floating Control Circuits	106
Series 90 Control Circuits	107
Motor Control Circuits	114

Electronic Control Fundamentals	119
Introduction	120
Definitions	120
Typical System	122
Components	122
Electronic Controller Fundamentals	129
Typical System Application	130
Microprocessor-Based/DDC Fundamentals	131
Introduction	133
Definitions	133
Background	134
Advantages	134
Controller Configuration	135
Types of Controllers	136
Controller Software	137
Controller Programming	142
Typical Applications	145
Indoor Air Quality Fundamentals	149
Introduction	151
Definitions	151
Abbreviations	153
Indoor Air Quality Concerns	154
Indoor Air Quality Control Applications	164
Bibliography	170
Smoke Management Fundamentals	171
Introduction	172
Definitions	172
Objectives	173
Design Considerations	173
Design Principles	175
Control Applications	178
Acceptance Testing	181
Leakage Rated Dampers	181
Bibliography	182
Building Management System Fundamentals	183
Introduction	184
Definitions	184
Background	185
System Configurations	186
System Functions	189
Integration of Other Systems	196

Control System Applications	199
Air Handling System Control Applications	201
Introduction	203
Abbreviations	203
Requirements for Effective Control	204
Applications-General	206
Valve and Damper Selection	207
Symbols	208
Ventilation Control Processes	209
Fixed Quantity of Outdoor Air Control	211
Heating Control Processes	223
Preheat Control Processes	228
Humidification Control Process	235
Cooling Control Processes	236
Dehumidification Control Processes	243
Heating System Control Process	246
Year-Round System Control Processes	248
ASHRAE Psychrometric Charts	261
Building Airflow System Control Applications	263
Introduction	265
Definitions	265
Airflow Control Fundamentals	266
Airflow Control Applications	280
References	290
Chiller, Boiler, and Distribution System Control Applications	291
Introduction	295
Abbreviations	295
Definitions	295
Symbols	296
Chiller System Control	297
Boiler System Control	327
Hot and Chilled Water Distribution Systems Control	335
High Temperature Water Heating System Control	374
District Heating Applications	380
Individual Room Control Applications	395
Introduction	397
Unitary Equipment Control	408
Hot Water Plant Considerations	424

Engineering Information	425
Valve Selection and Sizing	427
Introduction	428
Definitions	428
Valve Selection	432
Valve Sizing	437
Damper Selection and Sizing	445
Introduction	447
Definitions	447
Damper Selection	448
Damper Sizing	457
Damper Pressure Drop	462
Damper Applications	463
General Engineering Data	465
Introduction	466
Conversion Formulas and Tables	466
Electrical Data	473
Properties of Saturated Steam Data	476
Airflow Data	477
Moisture Content of Air Data	479
Index	483

CONTROL SYSTEM FUNDAMENTALS

Control Fundamentals

ENGINEERING MANUAL OF AUTOMATIC CONTROL

CONTENTS

Introduction	5
Definitions	5
HVAC System Characteristics	8
General	8
Heating	9
General	9
Heating Equipment	10
Cooling	11
General	11
Cooling Equipment	12
Dehumidification	12
Humidification	13
Ventilation	13
Filtration	14
Control System Characteristics	15
Controlled Variables	15
Control Loop	15
Control Methods	16
General	16
Analog and Digital Control	16
Control Modes	17
Two-Position Control	17
General	17
Basic Two-Position Control	17
Timed Two-Position Control	18
Step Control	19
Floating Control	20
Proportional Control	21
General	21
Compensation Control	22
Proportional-Integral (PI) Control	23
Proportional-Integral-Derivative (PID) Control	25
Enhanced Proportional-Integral-Derivative (EPID) Control	25
Adaptive Control	26
Process Characteristics	26
Load	26
Lag	27
General	27
Measurement Lag	27
Capacitance	28
Resistance	29
Dead Time	29
Control Application Guidelines	29

Control System Components	30
Sensing Elements	30
Temperature Sensing Elements	30
Pressure Sensing Elements	31
Moisture Sensing Elements	32
Flow Sensors	32
Proof-of-Operation Sensors	33
Transducers	33
Controllers	33
Actuators	33
Auxiliary Equipment.....	34
Characteristics and Attributes of Control Methods	35

INTRODUCTION

This section describes heating, ventilating, and air conditioning (HVAC) systems and discusses characteristics and components of automatic control systems. Cross-references are made to sections that provide more detailed information.

A correctly designed HVAC control system can provide a comfortable environment for occupants, optimize energy cost and consumption, improve employee productivity, facilitate efficient manufacturing, control smoke in the event of a fire, and support the operation of computer and telecommunications equipment. Controls are essential to the proper operation of the system and should be considered as early in the design process as possible.

Properly applied automatic controls ensure that a correctly designed HVAC system will maintain a comfortable environment and perform economically under a wide range of operating conditions. Automatic controls regulate HVAC system output in response to varying indoor and outdoor conditions to maintain general comfort conditions in office areas and provide narrow temperature and humidity limits where required in production areas for product quality.

Automatic controls can optimize HVAC system operation. They can adjust temperatures and pressures automatically to reduce demand when spaces are unoccupied and regulate heating and cooling to provide comfort conditions while limiting energy usage. Limit controls ensure safe operation of HVAC system equipment and prevent injury to personnel and damage to the system. Examples of limit controls are low-limit temperature controllers which help prevent water coils or heat exchangers from freezing and flow sensors for safe operation of some equipment (e.g., chillers). In the event of a fire, controlled air distribution can provide smoke-free evacuation passages, and smoke detection in ducts can close dampers to prevent the spread of smoke and toxic gases.

HVAC control systems can also be integrated with security access control systems, fire alarm systems, lighting control systems, and building and facility management systems to further optimize building comfort, safety, and efficiency.

DEFINITIONS

The following terms are used in this manual. Figure 1 at the end of this list illustrates a typical control loop with the components identified using terms from this list.

Analog: Continuously variable (e.g., a faucet controlling water from off to full flow).

Automatic control system: A system that reacts to a change or imbalance in the variable it controls by adjusting other variables to restore the system to the desired balance.

Algorithm: A calculation method that produces a control output by operating on an error signal or a time series of error signals.

Compensation control: A process of automatically adjusting the setpoint of a given controller to compensate for changes in a second measured variable (e.g., outdoor air temperature). For example, the hot deck setpoint is normally reset upward as the outdoor air temperature decreases. Also called “reset control”.

Control agent: The medium in which the manipulated variable exists. In a steam heating system, the control agent is the steam and the manipulated variable is the flow of the steam.

Control point: The actual value of the controlled variable (setpoint plus or minus offset).

Controlled medium: The medium in which the controlled variable exists. In a space temperature control system, the controlled variable is the space temperature and the controlled medium is the air within the space.

Controlled Variable: The quantity or condition that is measured and controlled.

Controller: A device that senses changes in the controlled variable (or receives input from a remote sensor) and derives the proper correction output.

Corrective action: Control action that results in a change of the manipulated variable. Initiated when the controlled variable deviates from setpoint.

Cycle: One complete execution of a repeatable process. In basic heating operation, a cycle comprises one on period and one off period in a two-position control system.

Cycling: A periodic change in the controlled variable from one value to another. Out-of-control analog cycling is called “hunting”. Too frequent on-off cycling is called “short cycling”. Short cycling can harm electric motors, fans, and compressors.

Cycling rate: The number of cycles completed per time unit, typically cycles per hour for a heating or cooling system. The inverse of the length of the period of the cycle.

- Deadband:** A range of the controlled variable in which no corrective action is taken by the controlled system and no energy is used. See also “zero energy band”.
- Deviation:** The difference between the setpoint and the value of the controlled variable at any moment. Also called “offset”.
- DDC:** Direct Digital Control. See also Digital and Digital control.
- Digital:** A series of on and off pulses arranged to convey information. Morse code is an early example. Processors (computers) operate using digital language.
- Digital control:** A control loop in which a microprocessor-based controller directly controls equipment based on sensor inputs and setpoint parameters. The programmed control sequence determines the output to the equipment.
- Droop:** A sustained deviation between the control point and the setpoint in a two-position control system caused by a change in the heating or cooling load.
- Enhanced proportional-integral-derivative (EPID) control:** A control algorithm that enhances the standard PID algorithm by allowing the designer to enter a startup output value and error ramp duration in addition to the gains and setpoints. These additional parameters are configured so that at startup the PID output varies smoothly to the control point with negligible overshoot or undershoot.
- Electric control:** A control circuit that operates on line or low voltage and uses a mechanical means, such as a temperature-sensitive bimetal or bellows, to perform control functions, such as actuating a switch or positioning a potentiometer. The controller signal usually operates or positions an electric actuator or may switch an electrical load directly or through a relay.
- Electronic control:** A control circuit that operates on low voltage and uses solid-state components to amplify input signals and perform control functions, such as operating a relay or providing an output signal to position an actuator. The controller usually furnishes fixed control routines based on the logic of the solid-state components.
- Final control element:** A device such as a valve or damper that acts to change the value of the manipulated variable. Positioned by an actuator.
- Hunting:** See Cycling.
- Lag:** A delay in the effect of a changed condition at one point in the system, or some other condition to which it is related. Also, the delay in response of the sensing element of a control due to the time required for the sensing element to sense a change in the sensed variable.
- Load:** In a heating or cooling system, the heat transfer that the system will be called upon to provide. Also, the work that the system must perform.
- Manipulated variable:** The quantity or condition regulated by the automatic control system to cause the desired change in the controlled variable.
- Measured variable:** A variable that is measured and may be controlled (e.g., discharge air is measured and controlled, outdoor air is only measured).
- Microprocessor-based control:** A control circuit that operates on low voltage and uses a microprocessor to perform logic and control functions, such as operating a relay or providing an output signal to position an actuator. Electronic devices are primarily used as sensors. The controller often furnishes flexible DDC and energy management control routines.
- Modulating:** An action that adjusts by minute increments and decrements.
- Offset:** A sustained deviation between the control point and the setpoint of a proportional control system under stable operating conditions.
- On/off control:** A simple two-position control system in which the device being controlled is either full on or full off with no intermediate operating positions available. Also called “two-position control”.
- Pneumatic control:** A control circuit that operates on air pressure and uses a mechanical means, such as a temperature-sensitive bimetal or bellows, to perform control functions, such as actuating a nozzle and flapper or a switching relay. The controller output usually operates or positions a pneumatic actuator, although relays and switches are often in the circuit.
- Process:** A general term that describes a change in a measurable variable (e.g., the mixing of return and outdoor air streams in a mixed-air control loop and heat transfer between cold water and hot air in a cooling coil). Usually considered separately from the sensing element, control element, and controller.
- Proportional band:** In a proportional controller, the control point range through which the controlled variable must pass to move the final control element through its full operating range. Expressed in percent of primary sensor span. Commonly used equivalents are “throttling range” and “modulating range”, usually expressed in a quantity of Engineering units (degrees of temperature).
- Proportional control:** A control algorithm or method in which the final control element moves to a position proportional to the deviation of the value of the controlled variable from the setpoint.

Proportional-Integral (PI) control: A control algorithm that combines the proportional (proportional response) and integral (reset response) control algorithms. Reset response tends to correct the offset resulting from proportional control. Also called “proportional-plus-reset” or “two-mode” control.

Proportional-Integral-Derivative (PID) control: A control algorithm that enhances the PI control algorithm by adding a component that is proportional to the rate of change (derivative) of the deviation of the controlled variable. Compensates for system dynamics and allows faster control response. Also called “three-mode” or “rate-reset” control.

Reset Control: See Compensation Control.

Sensing element: A device or component that measures the value of a variable.

Setpoint: The value at which the controller is set (e.g., the desired room temperature set on a thermostat). The desired control point.

Short cycling: See Cycling.

Step control: Control method in which a multiple-switch assembly sequentially switches equipment (e.g., electric heat, multiple chillers) as the controller input varies through the proportional band. Step controllers

may be actuator driven, electronic, or directly activated by the sensed medium (e.g., pressure, temperature).

Throttling range: In a proportional controller, the control point range through which the controlled variable must pass to move the final control element through its full operating range. Expressed in values of the controlled variable (e.g., Kelvins or degrees Celsius, percent relative humidity, kilopascals). Also called “proportional band”. In a proportional room thermostat, the temperature change required to drive the manipulated variable from full off to full on.

Time constant: The time required for a dynamic component, such as a sensor, or a control system to reach 63.2 percent of the total response to an instantaneous (or “step”) change to its input. Typically used to judge the responsiveness of the component or system.

Two-position control: See on/off control.

Zero energy band: An energy conservation technique that allows temperatures to float between selected settings, thereby preventing the consumption of heating or cooling energy while the temperature is in this range.

Zoning: The practice of dividing a building into sections for heating and cooling control so that one controller is sufficient to determine the heating and cooling requirements for the section.

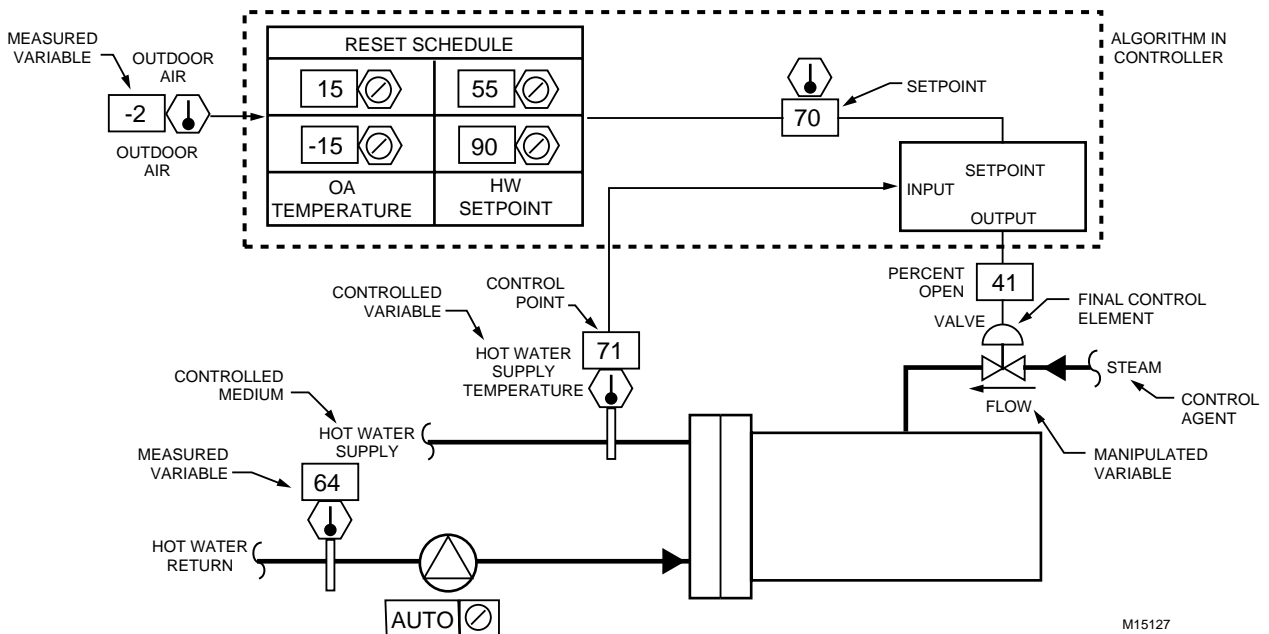

Fig. 1. Typical Control Loop.

HVAC SYSTEM CHARACTERISTICS

GENERAL

An HVAC system is designed according to capacity requirements, an acceptable combination of first cost and operating costs, system reliability, and available equipment space.

Figure 2 shows how an HVAC system may be distributed in a small commercial building. The system control panel, boilers, motors, pumps, and chillers are often located on the lower level. The cooling tower is typically located on the roof. Throughout the building are ductwork, fans, dampers, coils, air filters, heating units, and variable air volume (VAV) units and diffusers. Larger buildings often have separate systems for groups of floors or areas of the building.

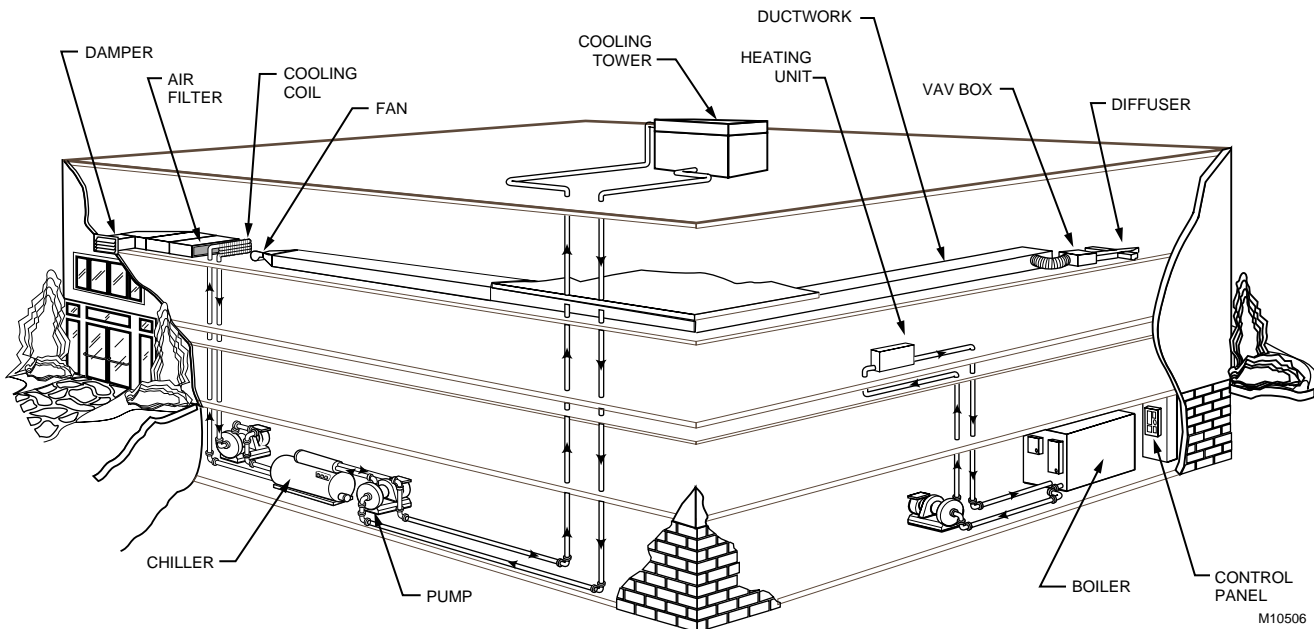

Fig. 2. Typical HVAC System in a Small Building.

The control system for a commercial building comprises many control loops and can be divided into central system and local- or zone-control loops. For maximum comfort and efficiency, all control loops should be tied together to share information and system commands using a building management system. Refer to the Building Management System Fundamentals section of this manual.

The basic control loops in a central air handling system can be classified as shown in Table 1.

Depending on the system, other controls may be required for optimum performance. Local or zone controls depend on the type of terminal units used.

Table 1. Functions of Central HVAC Control Loops.

Control Loop	Classification	Description
Ventilation	Basic	Coordinates operation of the outdoor, return, and exhaust air dampers to maintain the proper amount of ventilation air. Low-temperature protection is often required.
	Better	Measures and controls the volume of outdoor air to provide the proper mix of outdoor and return air under varying indoor conditions (essential in variable air volume systems). Low-temperature protection may be required.
Cooling	Chiller control	Maintains chiller discharge water at preset temperature or resets temperature according to demand.
	Cooling tower control	Controls cooling tower fans to provide the coolest water practical under existing wet bulb temperature conditions.
	Water coil control	Adjusts chilled water flow to maintain temperature.
	Direct expansion (DX) system control	Cycles compressor or DX coil solenoid valves to maintain temperature. If compressor is unloading type, cylinders are unloaded as required to maintain temperature.
Fan	Basic	Turns on supply and return fans during occupied periods and cycles them as required during unoccupied periods.
	Better	Adjusts fan volumes to maintain proper duct and space pressures. Reduces system operating cost and improves performance (essential for variable air volume systems).
Heating	Coil control	Adjusts water or steam flow or electric heat to maintain temperature.
	Boiler control	Operates burner to maintain proper discharge steam pressure or water temperature. For maximum efficiency in a hot water system, water temperature should be reset as a function of demand or outdoor temperature.

HEATING

GENERAL

Building heat loss occurs mainly through transmission, infiltration/exfiltration, and ventilation (Fig. 3).

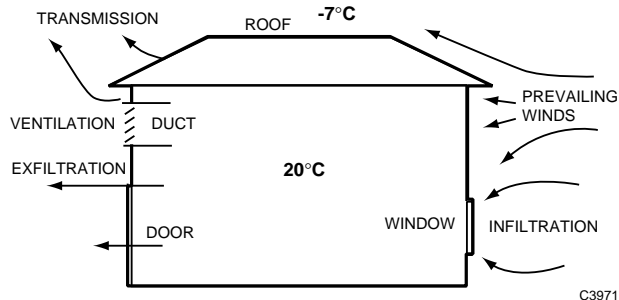

Fig. 3. Heat Loss from a Building.

The heating capacity required for a building depends on the design temperature, the quantity of outdoor air used, and the physical activity of the occupants. Prevailing winds affect the rate of heat loss and the degree of infiltration. The heating system must be sized to heat the building at the coldest outdoor temperature the building is likely to experience (outdoor design temperature).

Transmission is the process by which energy enters or leaves a space through exterior surfaces. The rate of energy transmission is calculated by subtracting the outdoor temperature from the indoor temperature and multiplying the result by the heat transfer coefficient of the surface materials. The rate of transmission varies with the thickness and construction of the exterior surfaces but is calculated the same way for all exterior surfaces:

$$\text{Energy Transmission per Unit Area and Unit Time} = (T_{IN} - T_{OUT}) \times \text{HTC}$$

Where:

- T_{IN} = indoor temperature
- T_{OUT} = outdoor temperature
- HTC = heat transfer coefficient

$$\text{HTC} = \frac{\text{joule}}{\text{Unit Time} \times \text{Unit Area} \times \text{Unit Temperature}}$$

Infiltration is the process by which outdoor air enters a building through walls, cracks around doors and windows, and open doors due to the difference between indoor and outdoor air pressures. The pressure differential is the result of temperature difference and air intake or exhaust caused by fan operation. Heat loss due to infiltration is a function of temperature difference and volume of air moved. Exfiltration is the process by which air leaves a building (e.g., through walls and cracks around doors and windows) and carries heat with it. Infiltration and exfiltration can occur at the same time.

Ventilation brings in fresh outdoor air that may require heating. As with heat loss from infiltration and exfiltration, heat loss from ventilation is a function of the temperature difference and the volume of air brought into the building or exhausted.

HEATING EQUIPMENT

Selecting the proper heating equipment depends on many factors, including cost and availability of fuels, building size and use, climate, and initial and operating cost trade-offs. Primary sources of heat include gas, oil, wood, coal, electrical, and solar energy. Sometimes a combination of sources is most economical. Boilers are typically fueled by gas and may have the option of switching to oil during periods of high demand. Solar heat can be used as an alternate or supplementary source with any type of fuel.

Figure 4 shows an air handling system with a hot water coil. A similar control scheme would apply to a steam coil. If steam or hot water is chosen to distribute the heat energy, high-efficiency boilers may be used to reduce life-cycle cost. Water generally is used more often than steam to transmit heat energy from the boiler to the coils or terminal units, because water requires fewer safety measures and is typically more efficient, especially in mild climates.

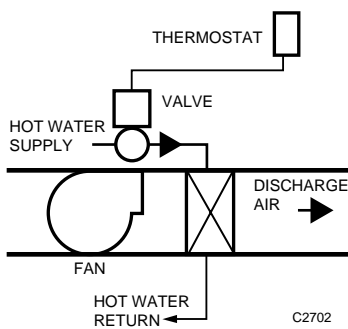

Fig. 4. System Using Heating Coil.

An air handling system provides heat by moving an air stream across a coil containing a heating medium, across an electric heating coil, or through a furnace. Unit heaters (Fig. 5) are typically used in shops, storage areas, stairwells, and docks. Panel heaters (Fig. 6) are typically used for heating floors and are usually installed in a slab or floor structure, but may be installed in a wall or ceiling.

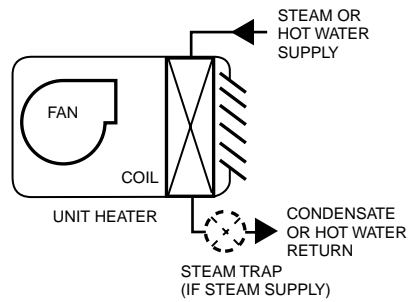

Fig. 5. Typical Unit Heater.

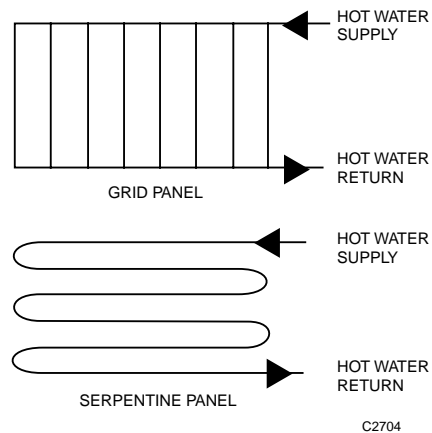

Fig. 6. Panel Heaters.

Unit ventilators (Fig. 7) are used in classrooms and may include both a heating and a cooling coil. Convection heaters (Fig. 8) are used for perimeter heating and in entries and corridors. Infrared heaters (Fig. 9) are typically used for spot heating in large areas (e.g., aircraft hangers, stadiums).

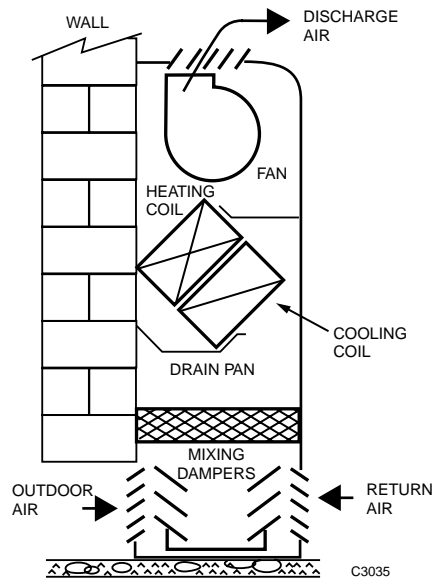

Fig. 7. Unit Ventilator.

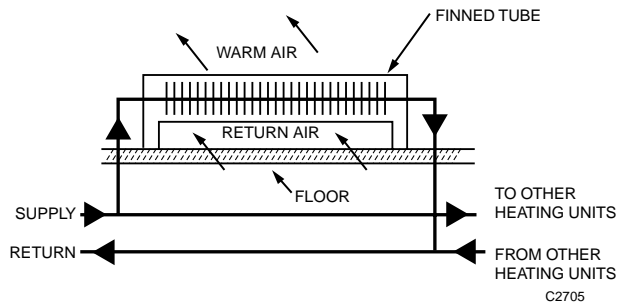

Fig. 8. Convection Heater.

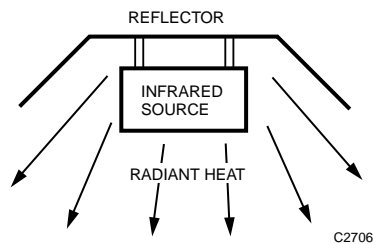

Fig. 9. Infrared Heater.

In mild climates, heat can be provided by a coil in the central air handling system or by a heat pump. Heat pumps have the advantage of switching between heating and cooling modes as required. Rooftop units provide packaged heating and cooling. Heating in a rooftop unit is usually by a gas- or oil-fired furnace or an electric heat coil. Steam and hot water coils are available as well. Perimeter heat is often required in colder climates, particularly under large windows.

A heat pump uses standard refrigeration components and a reversing valve to provide both heating and cooling within the same unit. In the heating mode, the flow of refrigerant through the coils is reversed to deliver heat from a heat source to the conditioned space. When a heat pump is used to exchange heat from the interior of a building to the perimeter, no additional heat source is needed.

A heat-recovery system is often used in buildings where a significant quantity of outdoor air is used. Several types of heat-recovery systems are available including heat pumps, runaround systems, rotary heat exchangers, and heat pipes.

In a runaround system, coils are installed in the outdoor air supply duct and the exhaust air duct. A pump circulates the medium (water or glycol) between the coils so that medium heated by the exhaust air preheats the outdoor air entering the system.

A rotary heat exchanger is a large wheel filled with metal mesh. One half of the wheel is in the outdoor air intake and the other half, in the exhaust air duct. As the wheel rotates, the metal mesh absorbs heat from the exhaust air and dissipates it in the intake air.

A heat pipe is a long, sealed, finned tube charged with a refrigerant. The tube is tilted slightly with one end in the outdoor air intake and the other end in the exhaust air. In a heating

application, the refrigerant vaporizes at the lower end in the warm exhaust air, and the vapor rises toward the higher end in the cool outdoor air, where it gives up the heat of vaporization and condenses. A wick carries the liquid refrigerant back to the warm end, where the cycle repeats. A heat pipe requires no energy input. For cooling, the process is reversed by tilting the pipe the other way.

Controls may be pneumatic, electric, electronic, digital, or a combination. Satisfactory control can be achieved using independent control loops on each system. Maximum operating efficiency and comfort levels can be achieved with a control system which adjusts the central system operation to the demands of the zones. Such a system can save enough in operating costs to pay for itself in a short time.

Controls for the air handling system and zones are specifically designed for a building by the architect, engineer, or team who designs the building. The controls are usually installed at the job site. Terminal unit controls are typically factory installed. Boilers, heat pumps, and rooftop units are usually sold with a factory-installed control package specifically designed for that unit.

COOLING

GENERAL

Both sensible and latent heat contribute to the cooling load of a building. Heat gain is sensible when heat is added to the conditioned space. Heat gain is latent when moisture is added to the space (e.g., by vapor emitted by occupants and other sources). To maintain a constant humidity ratio in the space, water vapor must be removed at a rate equal to its rate of addition into the space.

Conduction is the process by which heat moves between adjoining spaces with unequal space temperatures. Heat may move through exterior walls and the roof, or through floors, walls, or ceilings. Solar radiation heats surfaces which then transfer the heat to the surrounding air. Internal heat gain is generated by occupants, lighting, and equipment. Warm air entering a building by infiltration and through ventilation also contributes to heat gain.

Building orientation, interior and exterior shading, the angle of the sun, and prevailing winds affect the amount of solar heat gain, which can be a major source of heat. Solar heat received through windows causes immediate heat gain. Areas with large windows may experience more solar gain in winter than in summer. Building surfaces absorb solar energy, become heated, and transfer the heat to interior air. The amount of change in temperature through each layer of a composite surface depends on the resistance to heat flow and thickness of each material.

Occupants, lighting, equipment, and outdoor air ventilation and infiltration requirements contribute to internal heat gain. For example, an adult sitting at a desk produces about 117 watts. Incandescent lighting produces more heat than fluorescent lighting. Copiers, computers, and other office machines also contribute significantly to internal heat gain.

COOLING EQUIPMENT

An air handling system cools by moving air across a coil containing a cooling medium (e.g., chilled water or a refrigerant). Figures 10 and 11 show air handling systems that use a chilled water coil and a refrigeration evaporator (direct expansion) coil, respectively. Chilled water control is usually proportional, whereas control of an evaporator coil is two-position. In direct expansion systems having more than one coil, a thermostat controls a solenoid valve for each coil and the compressor is cycled by a refrigerant pressure control. This type of system is called a “pump down” system. Pump down may be used for systems having only one coil, but more often the compressor is controlled directly by the thermostat.

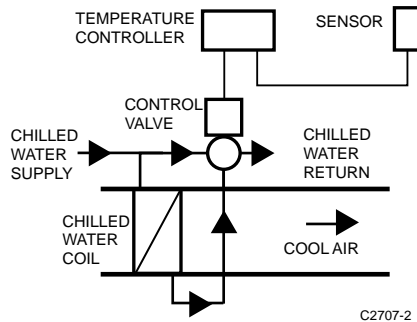

Fig. 10. System Using Cooling Coil.

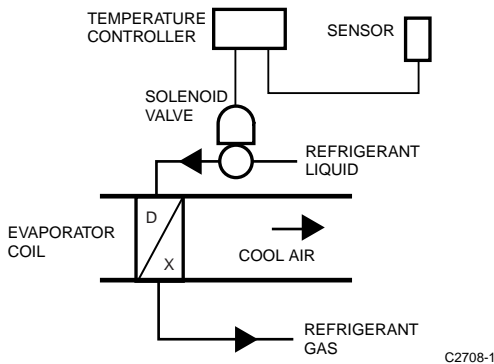

Fig. 11. System Using Evaporator (Direct Expansion) Coil.

Two basic types of cooling systems are available: chillers, typically used in larger systems, and direct expansion (DX) coils, typically used in smaller systems. In a chiller, the refrigeration system cools water which is then pumped to coils in the central air handling system or to the coils of fan coil units, a zone system, or other type of cooling system. In a DX system, the DX coil of the refrigeration system is located in the duct of the air handling system. Condenser cooling for chillers may be air or water (using a cooling tower), while DX systems are typically air cooled. Because water cooling is more efficient than air cooling, large chillers are always water cooled.

Compressors for chilled water systems are usually centrifugal, reciprocating, or screw type. The capacities of centrifugal and screw-type compressors can be controlled by varying the volume of refrigerant or controlling the compressor speed. DX system compressors are usually reciprocating and, in some systems, capacity can be controlled by unloading cylinders. Absorption refrigeration systems, which use heat energy directly to produce chilled water, are sometimes used for large chilled water systems.

While heat pumps are usually direct expansion, a large heat pump may be in the form of a chiller. Air is typically the heat source and heat sink unless a large water reservoir (e.g., ground water) is available.

Initial and operating costs are prime factors in selecting cooling equipment. DX systems can be less expensive than chillers. However, because a DX system is inherently two-position (on/off), it cannot control temperature with the accuracy of a chilled water system. Low-temperature control is essential in a DX system used with a variable air volume system.

For more information control of various system equipment, refer to the following sections of this manual:

- Chiller, Boiler, and Distribution System Control Applications.
- Air Handling System Control Applications.
- Individual Room Control Applications.

DEHUMIDIFICATION

Air that is too humid can cause problems such as condensation and physical discomfort. Dehumidification methods circulate moist air through cooling coils or sorption units. Dehumidification is required only during the cooling season. In those applications, the cooling system can be designed to provide dehumidification as well as cooling.

For dehumidification, a cooling coil must have a capacity and surface temperature sufficient to cool the air below its dew point. Cooling the air condenses water, which is then collected and drained away. When humidity is critical and the cooling system is used for dehumidification, the dehumidified air may be reheated to maintain the desired space temperature.

When cooling coils cannot reduce moisture content sufficiently, sorption units are installed. A sorption unit uses either a rotating granular bed of silica gel, activated alumina or hygroscopic salts (Fig. 12), or a spray of lithium chloride brine or glycol solution. In both types, the sorbent material absorbs moisture from the air and then the saturated sorbent material passes through a separate section of the unit that applies heat to remove moisture. The sorbent material gives up moisture to a stream of “scavenger” air, which is then exhausted. Scavenger air is often exhaust air or could be outdoor air.

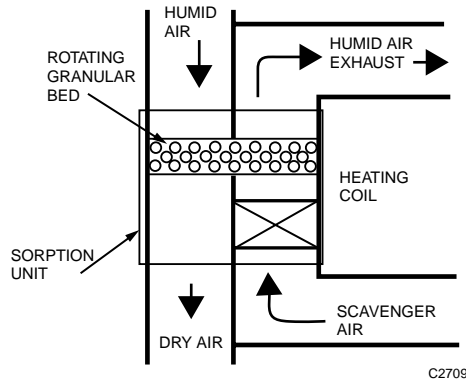

Fig. 12. Granular Bed Sorption Unit.

Sprayed cooling coils (Fig. 13) are often used for space humidity control to increase the dehumidifier efficiency and to provide year-round humidity control (winter humidification also).

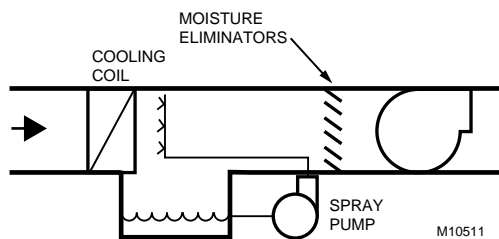

Fig. 13. Sprayed Coil Dehumidifier.

For more information on dehumidification, refer to the following sections of this manual:

- Psychrometric Chart Fundamentals.
- Air Handling System Control Applications.

HUMIDIFICATION

Low humidity can cause problems such as respiratory discomfort and static electricity. Humidifiers can humidify a space either directly or through an air handling system. For satisfactory environmental conditions, the relative humidity of the air should be 30 to 60 percent. In critical areas where explosive gases are present, 50 percent minimum is recommended. Humidification is usually required only during the heating season except in extremely dry climates.

Humidifiers in air handling systems typically inject steam directly into the air stream (steam injection), spray atomized water into the air stream (atomizing), or evaporate heated water from a pan in the duct into the air stream passing through the duct (pan humidification). Other types of humidifiers are a water spray and sprayed coil. In spray systems, the water can be heated for better vaporization or cooled for dehumidification.

For more information on humidification, refer to the following sections of this manual:

- Psychrometric Chart Fundamentals.
- Air Handling System Control Applications.

VENTILATION

Ventilation introduces outdoor air to replenish the oxygen supply and rid building spaces of odors and toxic gases. Ventilation can also be used to pressurize a building to reduce infiltration. While ventilation is required in nearly all buildings, the design of a ventilation system must consider the cost of heating and cooling the ventilation air. Ventilation air must be kept at the minimum required level except when used for free cooling (refer to ASHRAE Standard 62, Ventilation for Acceptable Indoor Air Quality).

To ensure high-quality ventilation air and minimize the amount required, the outdoor air intakes must be located to avoid building exhausts, vehicle emissions, and other sources of pollutants. Indoor exhaust systems should collect odors or contaminants at their source. The amount of ventilation a building requires may be reduced with air washers, high efficiency filters, absorption chemicals (e.g., activated charcoal), or odor modification systems.

Ventilation requirements vary according to the number of occupants and the intended use of the space. For a breakdown of types of spaces, occupancy levels, and required ventilation, refer to ASHRAE Standard 62.

Figure 14 shows a ventilation system that supplies 100 percent outdoor air. This type of ventilation system is typically used where odors or contaminants originate in the conditioned space (e.g., a laboratory where exhaust hoods and fans remove fumes). Such applications require make-up air that is conditioned to provide an acceptable environment.

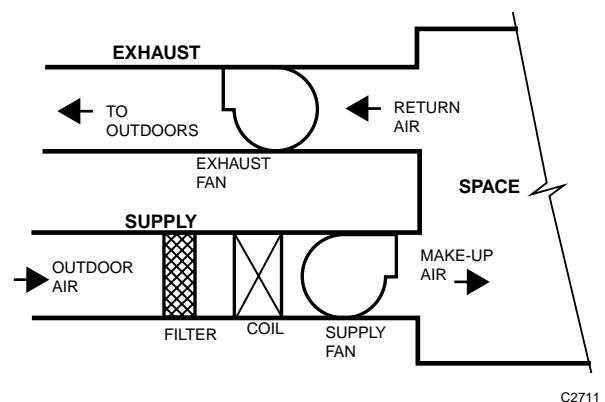

Fig. 14. Ventilation System Using 100 Percent Outdoor Air.

In many applications, energy costs make 100 percent outdoor air constant volume systems uneconomical. For that reason, other means of controlling internal contaminants are available, such as variable volume fume hood controls, space pressurization controls, and air cleaning systems.

A ventilation system that uses return air (Fig. 15) is more common than the 100 percent outdoor air system. The return-air ventilation system recirculates most of the return air from the system and adds outdoor air for ventilation. The return-air system may have a separate fan to overcome duct pressure

losses. The exhaust-air system may be incorporated into the air conditioning unit, or it may be a separate remote exhaust. Supply air is heated or cooled, humidified or dehumidified, and discharged into the space.

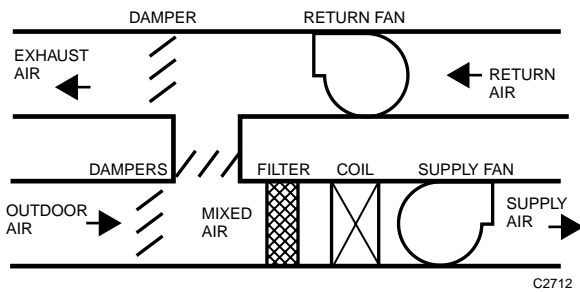

Fig. 15. Ventilation System Using Return Air.

Ventilation systems as shown in Figures 14 and 15 should provide an acceptable indoor air quality, utilize outdoor air for cooling (or to supplement cooling) when possible, and maintain proper building pressurization.

For more information on ventilation, refer to the following sections of this manual:

- Indoor Air Quality Fundamentals.
- Air Handling System Control Applications.
- Building Airflow System Control Applications.

FILTRATION

Air filtration is an important part of the central air handling system and is usually considered part of the ventilation system. Two basic types of filters are available: mechanical filters and electrostatic precipitation filters (also called electronic air cleaners). Mechanical filters are subdivided into standard and high efficiency.

Filters are selected according to the degree of cleanliness required, the amount and size of particles to be removed, and acceptable maintenance requirements. High-efficiency particulate air (HEPA) mechanical filters (Fig. 16) do not release the collected particles and therefore can be used for clean rooms and areas where toxic particles are released. HEPA filters significantly increase system pressure drop, which must be considered when selecting the fan. Figure 17 shows other mechanical filters.

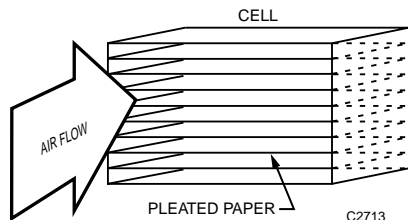

Fig. 16. HEPA Filter.

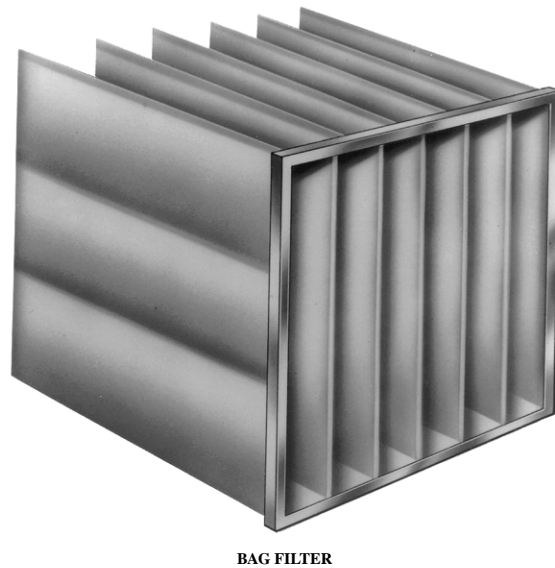
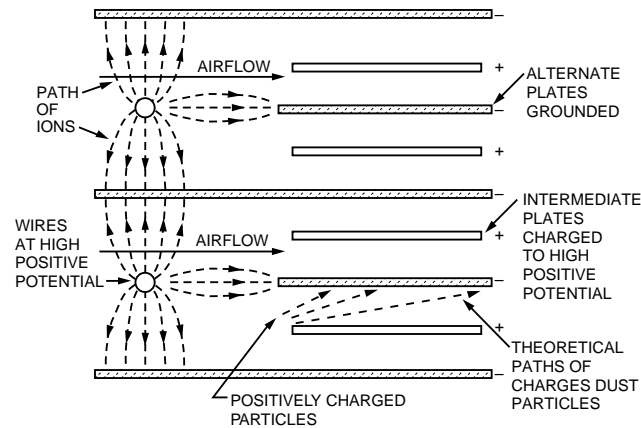

Fig. 17. Mechanical Filters.

Other types of mechanical filters include strainers, viscous coated filters, and diffusion filters. Straining removes particles that are larger than the spaces in the mesh of a metal filter and are often used as prefilters for electrostatic filters. In viscous coated filters, the particles passing through the filter fibers collide with the fibers and are held on the fiber surface. Diffusion removes fine particles by using the turbulence present in the air stream to drive particles to the fibers of the filter surface.

An electrostatic filter (Fig. 18) provides a low pressure drop but often requires a mechanical prefilter to collect large particles and a mechanical after-filter to collect agglomerated particles that may be blown off the electrostatic filter. An electrostatic filter electrically charges particles passing through an ionizing field and collects the charged particles on plates with an opposite electrical charge. The plates may be coated with an adhesive.



SOURCE: 1996 ASHRAE SYSTEMS AND EQUIPMENT HANDBOOK C2714

Fig. 18. Electrostatic Filter.

CONTROL SYSTEM CHARACTERISTICS

Automatic controls are used wherever a variable condition must be controlled. In HVAC systems, the most commonly controlled conditions are pressure, temperature, humidity, and rate of flow. Applications of automatic control systems range from simple residential temperature regulation to precision control of industrial processes.

CONTROLLED VARIABLES

Automatic control requires a system in which a controllable variable exists. An automatic control system controls the variable by manipulating a second variable. The second variable, called the manipulated variable, causes the necessary changes in the controlled variable.

In a room heated by air moving through a hot water coil, for example, the thermostat measures the temperature (controlled variable) of the room air (controlled medium) at a specified location. As the room cools, the thermostat operates a valve that regulates the flow (manipulated variable) of hot water (control agent) through the coil. In this way, the coil furnishes heat to warm the room air.

CONTROL LOOP

In an air conditioning system, the controlled variable is maintained by varying the output of the mechanical equipment by means of an automatic control loop. A control loop consists of an input sensing element, such as a temperature sensor; a controller that processes the input signal and produces an output signal; and a final control element, such as a valve, that operates according to the output signal.

The sensor can be separate from or part of the controller and is located in the controlled medium. The sensor measures the value of the controlled variable and sends the resulting signal to the controller. The controller receives the sensor signal, compares it to the desired value, or setpoint, and generates a correction signal to direct the operation of the controlled device. The controlled device varies the control agent to regulate the output of the control equipment that produces the desired condition.

HVAC applications use two types of control loops: open and closed. An open-loop system assumes a fixed relationship between a controlled condition and an external condition. An example of open-loop control would be the control of perimeter radiation heating based on an input from an outdoor air temperature sensor. A circulating pump and boiler are energized when an outdoor air temperature drops to a specified setting, and the water temperature or flow is proportionally controlled as a function of the outdoor temperature. An open-loop system does not take into account changing space conditions from internal heat gains, infiltration/exfiltration, solar gain, or other changing variables in the building. Open-loop control alone does not provide close control and may result in underheating or overheating. For this reason, open-loop systems are not common in residential or commercial applications.

A closed-loop system relies on measurement of the controlled variable to vary the controller output. Figure 19 shows a block diagram of a closed-loop system. An example of closed-loop control would be the temperature of discharge air in a duct determining the flow of hot water to the heating coils to maintain the discharge temperature at a controller setpoint.

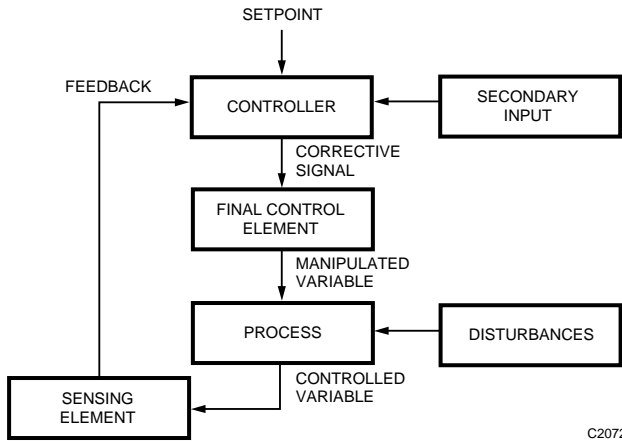

Fig. 19. Feedback in a Closed-Loop System.

In this example, the sensing element measures the discharge air temperature and sends a feedback signal to the controller. The controller compares the feedback signal to the setpoint. Based on the difference, or deviation, the controller issues a corrective signal to a valve, which regulates the flow of hot water to meet the process demand. Changes in the controlled variable thus reflect the demand. The sensing element continues to measure changes in the discharge air temperature and feeds the new condition back into the controller for continuous comparison and correction.

Automatic control systems use feedback to reduce the magnitude of the deviation and produce system stability as described above. A secondary input, such as the input from an outdoor air compensation sensor, can provide information about disturbances that affect the controlled variable. Using an input in addition to the controlled variable enables the controller to anticipate the effect of the disturbance and compensate for it, thus reducing the impact of disturbances on the controlled variable.

CONTROL METHODS

GENERAL

An automatic control system is classified by the type of energy transmission and the type of control signal (analog or digital) it uses to perform its functions.

The most common forms of energy for automatic control systems are electricity and compressed air. Systems may comprise one or both forms of energy.

Systems that use electrical energy are electromechanical, electronic, or microprocessor controlled. Pneumatic control systems use varying air pressure from the sensor as input to a controller, which in turn produces a pneumatic output signal to a final control element. Pneumatic, electromechanical, and electronic systems perform limited, predetermined control functions and sequences. Microprocessor-based controllers use digital control for a wide variety of control sequences.

Self-powered systems are a comparatively minor but still important type of control. These systems use the power of the measured variable to induce the necessary corrective action. For example, temperature changes at a sensor cause pressure or volume changes that are applied directly to the diaphragm or bellows in the valve or damper actuator.

Many complete control systems use a combination of the above categories. An example of a combined system is the control system for an air handler that includes electric on/off control of the fan and pneumatic control for the heating and cooling coils.

Various control methods are described in the following sections of this manual:

- Pneumatic Control Fundamentals.
- Electric Control Fundamentals.
- Electronic Control Fundamentals.
- Microprocessor-Based/DDC Fundamental.

See CHARACTERISTICS AND ATTRIBUTES OF CONTROL METHODS.

ANALOG AND DIGITAL CONTROL

Traditionally, analog devices have performed HVAC control. A typical analog HVAC controller is the pneumatic type which receives and acts upon data continuously. In a pneumatic controller, the sensor sends the controller a continuous pneumatic signal, the pressure of which is proportional to the value of the variable being measured. The controller compares the air pressure sent by the sensor to the desired value of air pressure as determined by the setpoint and sends out a control signal based on the comparison.

The digital controller receives electronic signals from sensors, converts the electronic signals to digital pulses (values), and performs mathematical operations on these values. The controller reconverts the output value to a signal to operate an actuator. The controller samples digital data at set time intervals, rather than reading it continually. The sampling method is called discrete control signaling. If the sampling interval for the digital controller is chosen properly, discrete output changes provide even and uninterrupted control performance.

Figure 20 compares analog and digital control signals. The digital controller periodically updates the process as a function of a set of measured control variables and a given set of control algorithms. The controller works out the entire computation, including the control algorithm, and sends a signal to an actuator. In many of the larger commercial control systems, an electronic-pneumatic transducer converts the electric output to a variable pressure output for pneumatic actuation of the final control element.

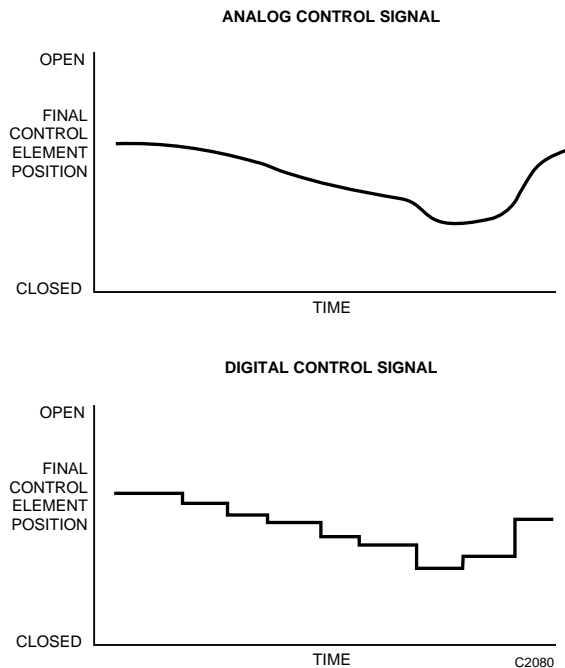

Fig. 20. Comparison of Analog and Digital Control Signals.

CONTROL MODES

Control systems use different control modes to accomplish their purposes. Control modes in commercial applications include two-position, step, and floating control; proportional, proportional-integral, and proportional-integral-derivative control; and adaptive control.

TWO-POSITION CONTROL

General

In two-position control, the final control element occupies one of two possible positions except for the brief period when it is passing from one position to the other. Two-position control is used in simple HVAC systems to start and stop electric motors on unit heaters, fan coil units, and refrigeration machines, to open water sprays for humidification, and to energize and deenergize electric strip heaters.

In two-position control, two values of the controlled variable (usually equated with on and off) determine the position of the final control element. Between these values is a zone called the “differential gap” or “differential” in which the controller cannot initiate an action of the final control element. As the controlled variable reaches one of the two values, the final control element assumes the position that corresponds to the demands of the controller, and remains there until the controlled variable changes to the other value. The final control element moves to the other position and remains there until the controlled variable returns to the other limit.

An example of differential gap would be in a cooling system in which the controller is set to open a cooling valve when the space temperature reaches 26°C, and to close the valve when the temperature drops to 25°C. The difference between the two temperatures (1°C or 1 Kelvin) is the differential gap. The controlled variable fluctuates between the two temperatures.

Basic two-position control works well for many applications. For close temperature control, however, the cycling must be accelerated or timed.

Basic Two-Position Control

In basic two-position control, the controller and the final control element interact without modification from a mechanical or thermal source. The result is cyclical operation of the controlled equipment and a condition in which the controlled variable cycles back and forth between two values (the on and off points) and is influenced by the lag in the system. The controller cannot change the position of the final control element until the controlled variable reaches one or the other of the two limits of the differential. For that reason, the differential is the minimum possible swing of the controlled variable. Figure 21 shows a typical heating system cycling pattern.

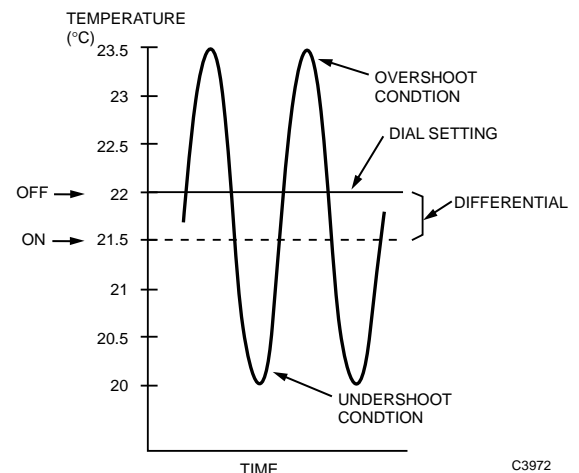

Fig. 21. Typical Operation of Basic Two-Position Control.

The overshoot and undershoot conditions shown in Figure 21 are caused by the lag in the system. When the heating system is energized, it builds up heat which moves into the space to warm the air, the contents of the space, and the thermostat. By the time the thermostat temperature reaches the off point (e.g., 22°C), the room air is already warmer than that temperature. When the thermostat shuts off the heat, the heating system dissipates its stored heat to heat the space even more, causing overshoot. Undershoot is the same process in reverse.

In basic two-position control, the presence of lag causes the controller to correct a condition that has already passed rather than one that is taking place or is about to take place. Consequently, basic two-position control is best used in systems with minimal total system lag (including transfer, measuring, and final control element lags) and where close control is not required.

Figure 22 shows a sample control loop for basic two-position control: a thermostat turning a furnace burner on or off in response to space temperature. Because the thermostat cannot catch up with fluctuations in temperature, overshoot and undershoot enable the temperature to vary, sometimes considerably. Certain industrial processes and auxiliary processes in air conditioning have small system lags and can use two-position control satisfactorily.

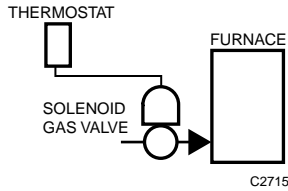

Fig. 22. Basic Two-Position Control Loop.

Timed Two-Position Control

GENERAL

The ideal method of controlling the temperature in a space is to replace lost heat or displace gained heat in exactly the amount needed. With basic two-position control, such exact operation is impossible because the heating or cooling system is either full on or full off and the delivery at any specific instant is either too much or too little. Timed two-position control, however, anticipates requirements and delivers measured quantities of heating or cooling on a percentage on-time basis to reduce control point fluctuations. The timing is accomplished by a heat anticipator in electric controls and by a timer in electronic and digital controls.

In timed two-position control, the basic interaction between the controller and the final control element is the same as for basic two-position control. However, the controller responds to gradual changes in the average value of the controlled variable rather than to cyclical fluctuations.

Overshoot and undershoot are reduced or eliminated because the heat anticipation or time proportioning feature results in a faster cycling rate of the mechanical equipment. The result is closer control of the variable than is possible in basic two-position control (Fig. 23).

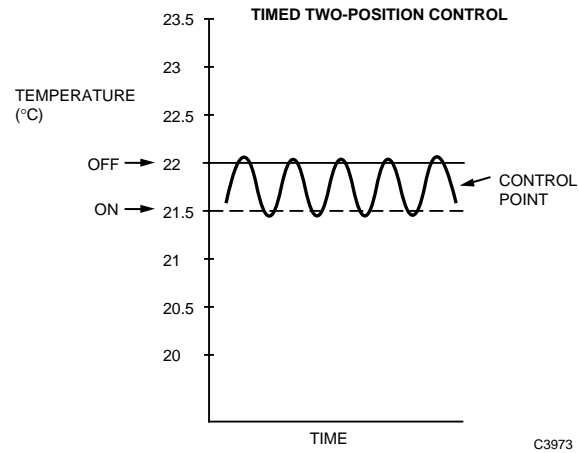
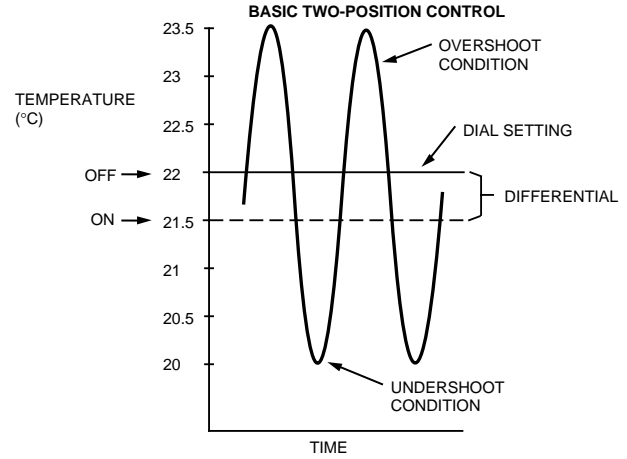

Fig. 23. Comparison of Basic Two-Position and Timed Two-Position Control.

HEAT ANTICIPATION

In electromechanical control, timed two-position control can be achieved by adding a heat anticipator to a bimetal sensing element. In a heating system, the heat anticipator is connected so that it energizes whenever the bimetal element calls for heat. On a drop in temperature, the sensing element acts to turn on both the heating system and the heat anticipator. The heat anticipator heats the bimetal element to its off point early and deenergizes the heating system and the heat anticipator. As the ambient temperature falls, the time required for the bimetal element to heat to the off point increases, and the cooling time decreases. Thus, the heat anticipator automatically changes the ratio of on time to off time as a function of ambient temperature.

Because the heat is supplied to the sensor only, the heat anticipation feature lowers the control point as the heat requirement increases. The lowered control point, called “droop”, maintains a lower temperature at design conditions and is discussed more thoroughly in the following paragraphs. Energizing the heater during thermostat off periods accomplishes anticipating action in cooling thermostats. In either case, the percentage on-time varies in proportion to the system load.

TIME PROPORTIONING

Time proportioning control provides more effective two-position control than heat anticipation control and is available with some electromechanical thermostats and in electronic and microprocessor-based controllers. Heat is introduced into the space using on/off cycles based on the actual heat load on the building and programmable time cycle settings. This method reduces large temperature swings caused by a large total lag and achieves a more even flow of heat.

In electromechanical thermostats, the cycle rate is adjustable by adjusting the heater. In electronic and digital systems, the total cycle time and the minimum on and off times of the controller are programmable. The total cycle time setting is determined primarily by the lag of the system under control. If the total cycle time setting is changed (e.g., from 10 minutes to 20 minutes), the resulting on/off times change accordingly (e.g., from 7.5 minutes on/2.5 minutes off to 15 minutes on/5 minutes off), but their ratio stays the same for a given load.

The cycle time in Figure 24 is set at ten minutes. At a 50 percent load condition, the controller, operating at setpoint, produces a 5 minute on/5 minute off cycle. At a 75 percent load condition, the on time increases to 7.5 minutes, the off time decreases to 2.5 minutes, and the opposite cycle ratio occurs at 25 percent load. All load conditions maintain the preset 10-minute total cycle.

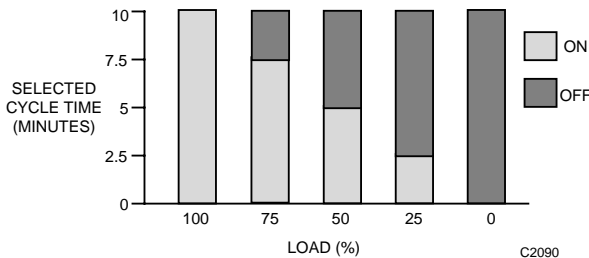

Fig. 24. Time Proportioning Control.

Because the controller responds to average temperature or humidity, it does not wait for a cyclic change in the controlled variable before signaling corrective action. Thus control system lags have no significant effect.

Droop in heating control is a lowering of the control point as the load on the system increases. In cooling control, droop is a raising of the control point. In digital control systems, droop is adjustable and can be set as low as one degree or even less. Figure 25 shows the relationship of droop to load.

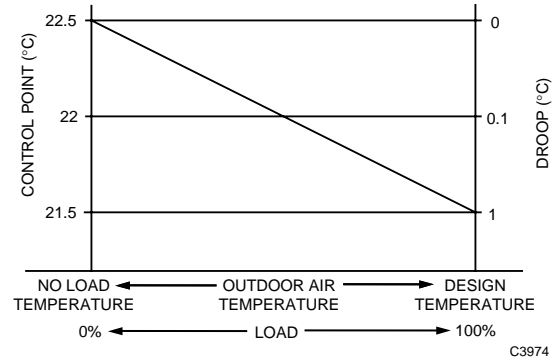

Fig. 25. Relationship between Control Point, Droop, and Load (Heating Control).

Time proportioning control of two-position loads is recommended for applications such as single-zone systems that require two-position control of heating and/or cooling (e.g., a gas-fired rooftop unit with direct-expansion cooling). Time proportioning control is also recommended for electric heat control, particularly for baseboard electric heat. With time proportioning control, care must be used to avoid cycling the controlled equipment more frequently than recommended by the equipment manufacturer.

STEP CONTROL

Step controllers operate switches or relays in sequence to enable or disable multiple outputs, or stages, of two-position devices such as electric heaters or reciprocating refrigeration compressors. Step control uses an analog signal to attempt to obtain an analog output from equipment that is typically either on or off. Figures 26 and 27 show that the stages may be arranged to operate with or without overlap of the operating (on/off) differentials. In either case, the typical two-position differentials still exist but the total output is proportioned.

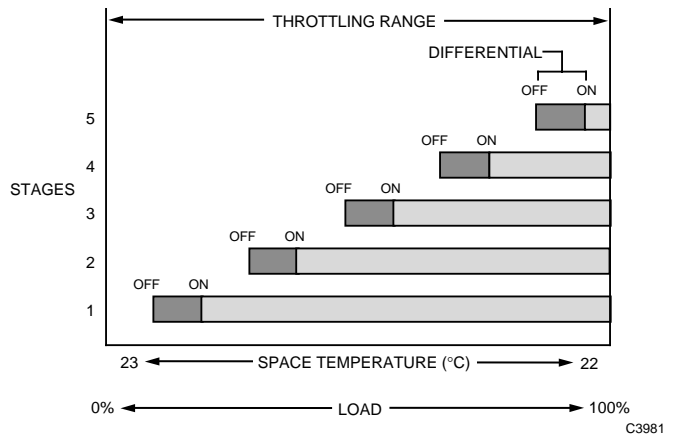

Fig. 26. Electric Heat Stages.

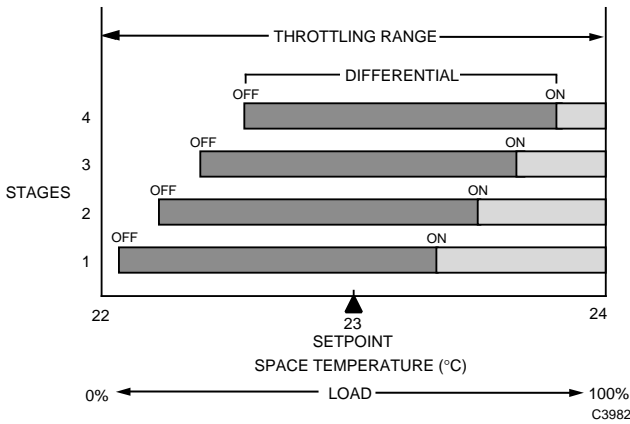

Fig. 27. Staged Reciprocating Chiller Control.

Figure 28 shows step control of sequenced DX coils and electric heat. On a rise in temperature through the throttling range at the thermostat, the heating stages sequence off. On a further rise after a deadband, the cooling stages turn on in sequence.

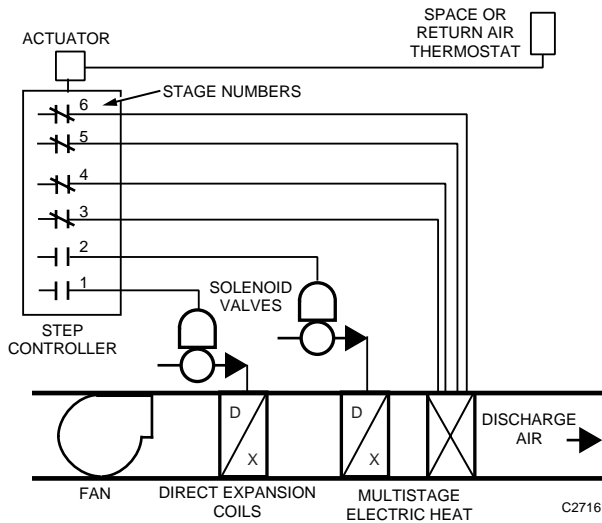

Fig. 28. Step Control with Sequenced DX Coils and Electric Heat.

A variation of step control used to control electric heat is step-plus-proportional control, which provides a smooth transition between stages. This control mode requires one of the stages to be a proportional modulating output and the others, two-position. For most efficient operation, the proportional modulating stage should have at least the same capacity as one two-position stage.

Starting from no load, as the load on the equipment increases, the modulating stage proportions its load until it reaches full output. Then, the first two-position stage comes full on and the modulating stage drops to zero output and begins to proportion its output again to match the increasing load. When the modulating stage again reaches full output, the second two-position stage comes

full on, the modulating stage returns to zero, and the sequence repeats until all stages required to meet the load condition are on. On a decrease in load, the process reverses.

With microprocessor controls, step control is usually done with multiple, digital, on-off outputs since software allows easily adjustable on-to-off per stage and interstage differentials as well as no-load and time delayed startup and minimum on and off adjustments.

FLOATING CONTROL

Floating control is a variation of two-position control and is often called “three-position control”. Floating control is not a common control mode, but is available in most microprocessor-based control systems.

Floating control requires a slow-moving actuator and a fast-responding sensor selected according to the rate of response in the controlled system. If the actuator should move too slowly, the controlled system would not be able to keep pace with sudden changes; if the actuator should move too quickly, two-position control would result.

Floating control keeps the control point near the setpoint at any load level, and can only be used on systems with minimal lag between the controlled medium and the control sensor. Floating control is used primarily for discharge control systems where the sensor is immediately downstream from the coil, damper, or device that it controls. An example of floating control is the regulation of static pressure in a duct (Fig. 29).

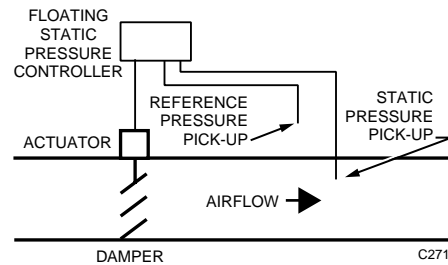

Fig. 29. Floating Static Pressure Control.

In a typical application, the control point moves in and out of the deadband, crossing the switch differential (Fig. 30). A drop in static pressure below the controller setpoint causes the actuator to drive the damper toward open. The narrow differential of the controller stops the actuator after it has moved a short distance. The damper remains in this position until the static pressure further decreases, causing the actuator to drive the damper further open. On a rise in static pressure above the setpoint, the reverse occurs. Thus, the control point can float between open and closed limits and the actuator does not move. When the control point moves out of the deadband, the controller moves the actuator toward open or closed until the control point moves into the deadband again.

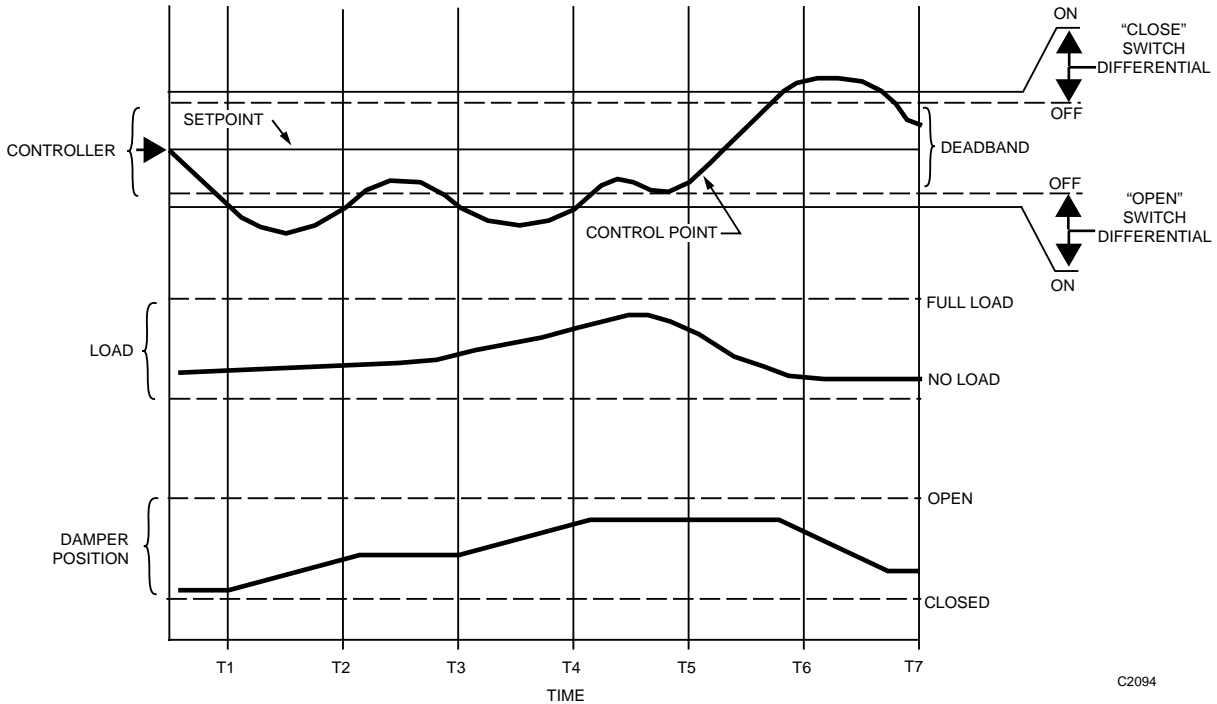

Fig. 30. Floating Control.

PROPORTIONAL CONTROL

General

Proportional control proportions the output capacity of the equipment (e.g., the percent a valve is open or closed) to match the heating or cooling load on the building, unlike two-position control in which the mechanical equipment is either full on or full off. In this way, proportional control achieves the desired heat replacement or displacement rate.

In a chilled water cooling system, for example (Fig. 31), the sensor is placed in the discharge air. The sensor measures the air temperature and sends a signal to the controller. If a correction is required, the controller calculates the change and sends a new signal to the valve actuator. The actuator repositions the valve to change the water flow in the coil, and thus the discharge temperature.

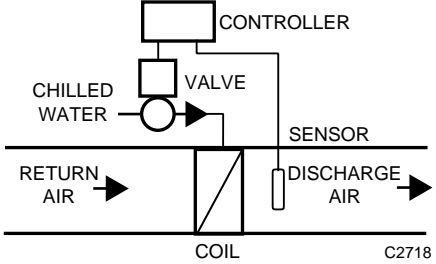

Fig. 31. Proportional Control Loop.

In proportional control, the final control element moves to a position proportional to the deviation of the value of the controlled variable from the setpoint. The position of the final control element is a linear function of the value of the controlled variable (Fig. 32).

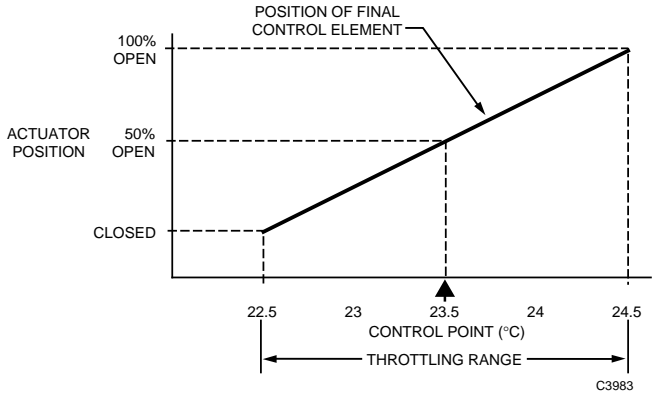

Fig. 32. Final Control Element Position as a Function of the Control Point (Cooling System).

The final control element is seldom in the middle of its range because of the linear relationship between the position of the final control element and the value of the controlled variable. In proportional control systems, the setpoint is typically the middle of the throttling range, so there is usually an offset between control point and setpoint.

An example of offset would be the proportional control of a chilled water coil used to cool a space. When the cooling load is 50 percent, the controller is in the middle of its throttling range, and there is no offset. As the outdoor temperature increases, the room temperature rises and more cooling is required to maintain the space temperature. The coil valve must open wider to deliver the required cooling and remain in that position as long as the increased requirement exists. Because the position of the final control element is proportional to the amount of deviation, the temperature must deviate from the setpoint and sustain that deviation to open the coil valve as far as required.

Figure 33 shows that when proportional control is used in a heating application, as the load condition increases from 50 percent, offset increases toward cooler. As the load condition decreases, offset increases toward warmer. The opposite occurs in a cooling application.

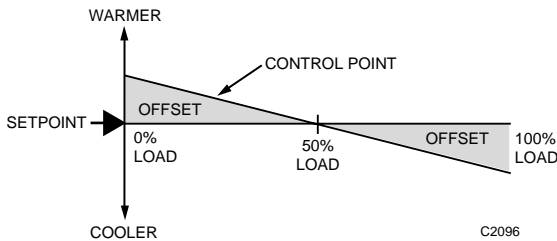

Fig. 33. Relationship of Offset to Load (Heating Application).

The throttling range is the amount of change in the controlled variable required for the controller to move the controlled device through its full operating range. The amount of change is expressed in degrees kelvins for temperature, in percentages for relative humidity, and in pascals or kilopascals for pressure. For some controllers, throttling range is referred to as “proportional band”. Proportional band is throttling range expressed as a percentage of the controller sensor span:

$$\text{Proportional Band} = \frac{\text{Throttling Range}}{\text{Sensor Span}} \times 100$$

“Gain” is a term often used in industrial control systems for the change in the controlled variable. Gain is the reciprocal of proportional band:

$$\text{Gain} = \frac{100}{\text{Proportional Band}}$$

The output of the controller is proportional to the deviation of the control point from setpoint. A proportional controller can be mathematically described by:

$$V = KE + M$$

Where:

- V = output signal
- K = proportionality constant (gain)
- E = deviation (control point - setpoint)
- M = value of the output when the deviation is zero (Usually the output value at 50 percent or the middle of the output range. The generated control signal correction is added to or subtracted from this value. Also called “bias” or “manual reset”.)

Although the control point in a proportional control system is rarely at setpoint, the offset may be acceptable. Compensation, which is the resetting of the setpoint to compensate for varying load conditions, may also reduce the effect of proportional offset for more accurate control. An example of compensation is resetting boiler water temperature based on outdoor air temperature. Compensation is also called “reset control” or “cascade control”.

Compensation Control

GENERAL

Compensation is a control technique available in proportional control in which a secondary, or compensation, sensor resets the setpoint of the primary sensor. An example of compensation would be the outdoor temperature resetting the discharge temperature of a fan system so that the discharge temperature increases as the outdoor temperature decreases. The sample reset schedule in Table 2 is shown graphically in Figure 34. Figure 35 shows a control diagram for the sample reset system.

Table 2. Sample Reset Schedule.

Condition	Outdoor Air Temperature (°C)	Discharge Air Temperature (°C)
Outdoor design temperature	-20	40
Light load	20	20

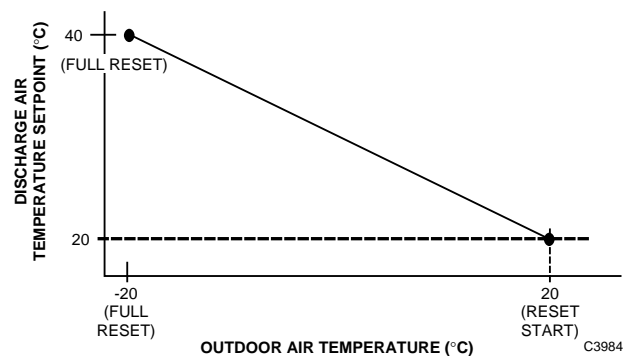

Fig. 34. Typical Reset Schedule for Discharge Air Control.

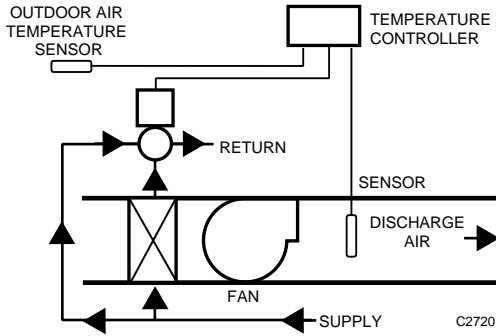

Fig. 35. Discharge Air Control Loop with Reset.

Compensation can either increase or decrease the setpoint as the compensation input increases. Increasing the setpoint by adding compensation on an increase in the compensation variable is often referred to as positive or summer compensation. Increasing the setpoint by adding compensation on a decrease in the compensation variable is often referred to as negative or winter compensation. Compensation is most commonly used for temperature control, but can also be used with a humidity or other control system.

Some controllers provide compensation start point capability. Compensation start point is the value of the compensation sensor at which it starts resetting the controller primary sensor setpoint.

COMPENSATION AUTHORITY

Compensation authority is the ratio of the effect of the compensation sensor relative to the effect of the primary sensor. Authority is stated in percent.

The basic equation for compensation authority is:

$$\text{Authority} = \frac{\text{Change in setpoint}}{\text{Change in compensation input}} \times 100$$

For proportional controllers, the throttling range (TR) is included in the equation. Two equations are required when the throttling range is included. For direct-acting or positive reset, in which the setpoint increases as the compensation input increases, the equation is:

$$\text{Authority} = \frac{\text{Change in setpoint} - \text{TR}}{\text{Change in compensation input}} \times 100$$

Direct-acting compensation is commonly used to prevent condensation on windows by resetting the relative humidity setpoint downward as the outdoor temperature decreases.

For reverse-acting or negative compensation, in which the setpoint decreases as the compensation input increases, the equation is:

$$\text{Authority} = \frac{\text{Change in setpoint} + \text{TR}}{\text{Change in compensation input}} \times 100$$

In an application requiring negative compensation, a change in outdoor air temperature at the compensation sensor from -18 to 16°C resets the hot water supply temperature (primary sensor) setpoint from 94 to 38°C. Assuming a throttling range of 7 Kelvins, the required authority is calculated as follows:

$$\begin{aligned} \text{Authority} &= \frac{\text{Change in setpoint} + \text{TR}}{\text{Change in compensation input}} \times 100 \\ &= \frac{94 - 38 + 7}{16 - (-18)} \times 100 \end{aligned}$$

Authority = 185%

The previous example assumes that the spans of the two sensors are equal. If sensors with unequal spans are used, a correction factor is added to the formula:

$$\begin{aligned} \text{Authority} &= \\ &\underbrace{\frac{\text{Compensation sensor span}}{\text{Primary sensor span}} \times \frac{\text{Change in setpoint} \pm \text{TR}}{\text{Change in compensation input}} \times 100}_{\text{Correction Factor}} \end{aligned}$$

Assuming the same conditions as in the previous example, a supply water temperature sensor range of 5 to 115°C (span of 110 Kelvins), an outdoor air temperature (compensation) sensor range of -30 to 30°C (span of 60 Kelvins), and a throttling range of 5 Kelvins, the calculation for negative reset would be as follows:

$$\text{Authority} = \frac{60}{110} \times \frac{94 - 38 + 5}{16 - (-18)} \times 100$$

Authority = 98%

The effects of throttling range may be disregarded with PI reset controls.

PROPORTIONAL-INTEGRAL (PI) CONTROL

In the proportional-integral (PI) control mode, reset of the control point is automatic. PI control, also called “proportional-plus-reset” control, virtually eliminates offset and makes the proportional band nearly invisible. As soon as the controlled variable deviates above or below the setpoint and offset develops, the proportional band gradually and automatically shifts, and the variable is brought back to the setpoint. The major difference between proportional and PI control is that proportional control is limited to a single final control element position for each value of the controlled variable. PI control changes the final control element position to accommodate load changes while keeping the control point at or very near the setpoint.

The reset action of the integral component shifts the proportional band as necessary around the setpoint as the load on the system changes. The graph in Figure 36 shows the shift of the proportional band of a PI controller controlling a normally open heating valve. The shifting of the proportional band keeps the control point at setpoint by making further corrections in the control signal. Because offset is eliminated, the proportional band is usually set fairly wide to ensure system stability under all operating conditions.

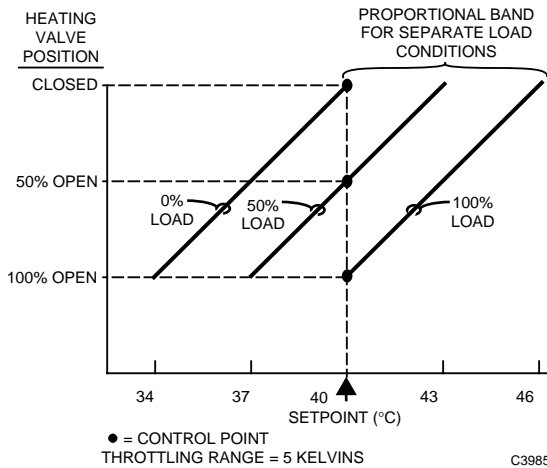

Fig. 36. Proportional Band Shift Due to Offset.

Reset of the control point is not instantaneous. Whenever the load changes, the controlled variable changes, producing an offset. The proportional control makes an immediate correction, which usually still leaves an offset. The integral function of the controller then makes control corrections over time to bring the control point back to setpoint (Fig. 37). In addition to a proportional band adjustment, the PI controller also has a reset time adjustment that determines the rate at which the proportional band shifts when the controlled variable deviates any given amount from the setpoint.

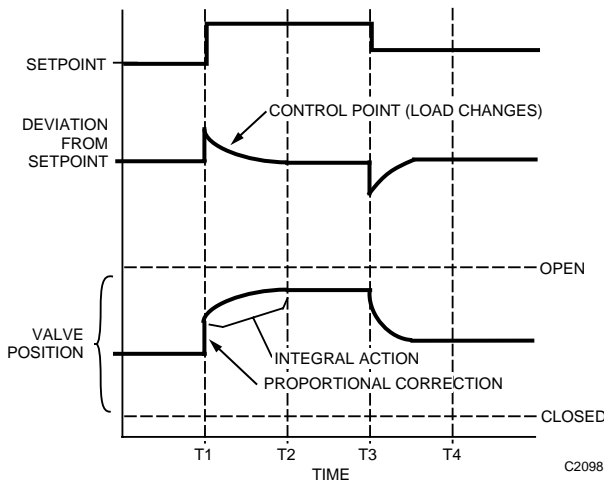

Fig. 37. Proportional-Integral Control Response to Load Changes.

Reset error correction time is proportional to the deviation of the controlled variable. For example, a four-percent deviation from the setpoint causes a continuous shift of the proportional band at twice the rate of shift for a two-percent deviation. Reset is also proportional to the duration of the deviation. Reset accumulates as long as there is offset, but ceases as soon as the controlled variable returns to the setpoint.

With the PI controller, therefore, the position of the final control element depends not only upon the location of the controlled variable within the proportional band (proportional band adjustment) but also upon the duration and magnitude of the deviation of the controlled variable from the setpoint (reset time adjustment). Under steady state conditions, the control point and setpoint are the same for any load conditions, as shown in Figure 37.

PI control adds a component to the proportional control algorithm and is described mathematically by:

$$V = KE + \underbrace{\frac{K}{T_1} \int E dt}_{\text{Integral}} + M$$

Where:

- V = output signal
- K = proportionality constant (gain)
- E = deviation (control point - setpoint)
- T₁ = reset time
- K/T₁ = reset gain
- dt = differential of time (increment in time)
- M = value of the output when the deviation is zero

Integral windup, or an excessive overshoot condition, can occur in PI control. Integral windup is caused by the integral function making a continued correction while waiting for feedback on the effects of its correction. While integral action keeps the control point at setpoint during steady state conditions, large overshoots are possible at start-up or during system upsets (e.g., setpoint changes or large load changes). On many systems, short reset times also cause overshoot.

Integral windup may occur with one of the following:

- When the system is off.
- When the heating or cooling medium fails or is not available.
- When one control loop overrides or limits another.

Integral windup can be avoided and its effects diminished. At start-up, some systems disable integral action until measured variables are within their respective proportional bands. Systems often provide integral limits to reduce windup due to load changes. The integral limits define the extent to which integral action can adjust a device (the percent of full travel). The limit is typically set at 50 percent.

PROPORTIONAL-INTEGRAL-DERIVATIVE (PID) CONTROL

Proportional-integral-derivative (PID) control adds the derivative function to PI control. The derivative function opposes any change and is proportional to the rate of change. The more quickly the control point changes, the more corrective action the derivative function provides.

If the control point moves away from the setpoint, the derivative function outputs a corrective action to bring the control point back more quickly than through integral action alone. If the control point moves toward the setpoint, the derivative function reduces the corrective action to slow down the approach to setpoint, which reduces the possibility of overshoot.

The rate time setting determines the effect of derivative action. The proper setting depends on the time constants of the system being controlled.

The derivative portion of PID control is expressed in the following formula. Note that only a change in the magnitude of the deviation can affect the output signal.

$$V = KT_D \frac{dE}{dt}$$

Where:

- V = output signal
- K = proportionality constant (gain)
- T_D = rate time (time interval by which the derivative advances the effect of proportional action)
- KT_D = rate gain constant
- dE/dt = derivative of the deviation with respect to time (error signal rate of change)

The complete mathematical expression for PID control becomes:

$$V = \underbrace{KE}_{\text{Proportional}} + \underbrace{\frac{K}{T_1} \int E dt}_{\text{Integral}} + \underbrace{KT_D \frac{dE}{dt}}_{\text{Derivative}} + M$$

Where:

- V = output signal
- K = proportionality constant (gain)
- E = deviation (control point - setpoint)
- T₁ = reset time
- K/T₁ = reset gain
- dt = differential of time (increment in time)
- T_D = rate time (time interval by which the derivative advances the effect of proportional action)
- KT_D = rate gain constant
- dE/dt = derivative of the deviation with respect to time (error signal rate of change)
- M = value of the output when the deviation is zero

The graphs in Figures 38, 39, and 40 show the effects of all three modes on the controlled variable at system start-up. With proportional control (Fig. 38), the output is a function of the deviation of the controlled variable from the setpoint. As the control point stabilizes, offset occurs. With the addition of integral control (Fig. 39), the control point returns to setpoint over a period of time with some degree of overshoot. The significant difference is the elimination of offset after the system has stabilized. Figure 40 shows that adding the derivative element reduces overshoot and decreases response time.

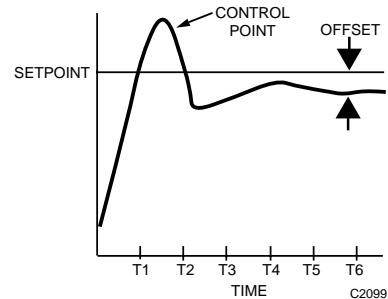

Fig. 38. Proportional Control.

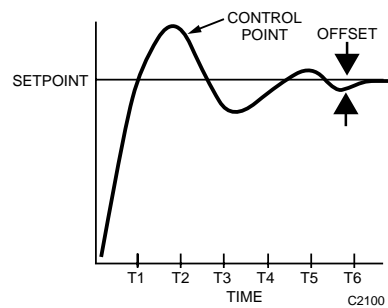

Fig. 39. Proportional-Integral Control.

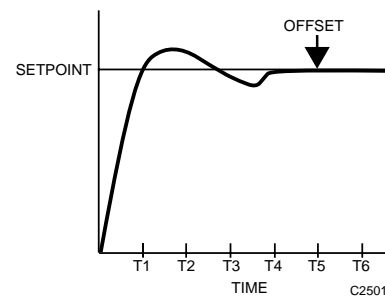

Fig. 40. Proportional-Integral-Derivative Control.

ENHANCED PROPORTIONAL-INTEGRAL-DERIVATIVE (EPID) CONTROL

The startup overshoot, or undershoot in some applications, noted in Figures 38, 39, and 40 is attributable to the very large error often present at system startup. Microprocessor-based PID startup performance may be greatly enhanced by exterior error management appendages available with enhanced proportional-integral-derivative (EPID) control. Two basic EPID functions are start value and error ramp time.

The start value EPID setpoint sets the output to a fixed value at startup. For a VAV air handling system supply fan, a suitable value might be twenty percent, a value high enough to get the fan moving to prove operation to any monitoring system and to allow the motor to self cool. For a heating, cooling, and ventilating air handling unit sequence, a suitable start value would be thirty-three percent, the point at which the heating, ventilating (economizer), and mechanical cooling demands are all zero. Additional information is available in the Air Handling System Control Applications section.

The error ramp time determines the time duration during which the PID error (setpoint minus input) is slowly ramped, linear to the ramp time, into the PID controller. The controller thus arrives at setpoint in a tangential manner without overshoot, undershoot, or cycling. See Figure 41.

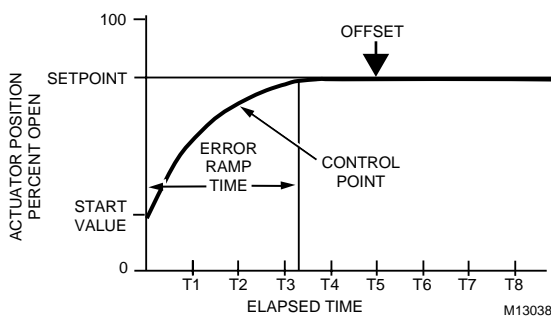

Fig. 41. Enhanced Proportional-Integral-Derivative (EPID) Control.

ADAPTIVE CONTROL

Adaptive control is available in some microprocessor-based controllers. Adaptive control algorithms enable a controller to adjust its response for optimum control under all load conditions. A controller that has been tuned to control accurately under one set of conditions cannot always respond well when the conditions change, such as a significant load change or changeover from heating to cooling or a change in the velocity of a controlled medium.

An adaptive control algorithm monitors the performance of a system and attempts to improve the performance by adjusting controller gains or parameters. One measurement of performance is the amount of time the system requires to react to a disturbance; usually the shorter the time, the better the performance. The methods used to modify the gains or parameters are determined by the type of adaptive algorithm. Neural networks are used in some adaptive algorithms.

An example of a good application for adaptive control is discharge temperature control of the central system cooling coil for a VAV system. The time constant of a sensor varies as a function of the velocity of the air (or other fluid). Thus the time constant of the discharge air sensor in a VAV system is constantly changing. The change in sensor response affects the system control so the adaptive control algorithm adjusts system parameters such as the reset and rate settings to maintain optimum system performance.

Adaptive control is also used in energy management programs such as optimum start. The optimum start program enables an HVAC system to start as late as possible in the morning and still reach the comfort range by the time the building is occupied for the lease energy cost. To determine the amount of time required to heat or cool the building, the optimum start program uses factors based on previous building response, HVAC system characteristics, and current weather conditions. The algorithm monitors controller performance by comparing the actual and calculated time required to bring the building into the comfort range and tries to improve this performance by calculating new factors.

PROCESS CHARACTERISTICS

As pumps and fans distribute the control agent throughout the building, an HVAC system exhibits several characteristics that must be understood in order to apply the proper control mode to a particular building system.

LOAD

Process load is the condition that determines the amount of control agent the process requires to maintain the controlled variable at the desired level. Any change in load requires a change in the amount of control agent to maintain the same level of the controlled variable.

Load changes or disturbances are changes to the controlled variable caused by altered conditions in the process or its surroundings. The size, rate, frequency, and duration of disturbances change the balance between input and output.

Four major types of disturbances can affect the quality of control:

- Supply disturbances
- Demand disturbances
- Setpoint changes
- Ambient (environmental) variable changes

Supply disturbances are changes in the manipulated variable input into the process to control the controlled variable. An example of a supply disturbance would be a decrease in the temperature of hot water being supplied to a heating coil. More flow is required to maintain the temperature of the air leaving the coil.

Demand disturbances are changes in the controlled medium that require changes in the demand for the control agent. In the case of a steam-to-water converter, the hot water supply temperature is the controlled variable and the water is the controlled medium (Fig. 42). Changes in the flow or temperature of the water returning to the converter indicate a demand load change. An increased flow of water requires an increase in the flow of the control agent (steam) to maintain the water temperature. An increase in the returning water temperature, however, requires a decrease in steam to maintain the supply water temperature.

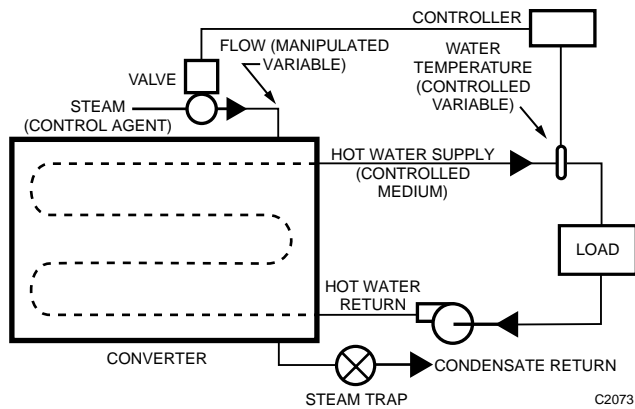

Fig. 42. Steam-to-Water Converter.

A setpoint change can be disruptive because it is a sudden change in the system and causes a disturbance to the hot water supply. The resulting change passes through the entire process before being measured and corrected.

Ambient (environmental) variables are the conditions surrounding a process, such as temperature, pressure, and humidity. As these conditions change, they appear to the control system as changes in load.

LAG

General

Time delays, or lag, can prevent a control system from providing an immediate and complete response to a change in the controlled variable. Process lag is the time delay between the introduction of a disturbance and the point at which the controlled variable begins to respond. Capacitance, resistance, and/or dead time of the process contribute to process lag and are discussed later in this section.

One reason for lag in a temperature control system is that a change in the controlled variable (e.g., space temperature) does not transfer instantly. Figure 43 shows a thermostat controlling the temperature of a space. As the air in the space loses heat, the space temperature drops. The thermostat sensing element cannot measure the temperature drop immediately because there is a lag before the air around the thermostat loses heat. The sensing element also requires a measurable time to cool. The result is a lag between the time the space begins to lose heat and the time corrective action is initiated.

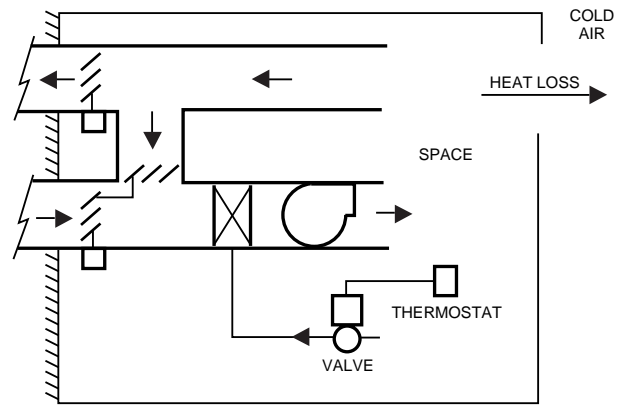

Fig. 43. Heat Loss in a Space Controlled by a Thermostat.

Lag also occurs between the release of heat into the space, the space warming, and the thermostat sensing the increased temperature. In addition, the final control element requires time to react, the heat needs time to transfer to the controlled medium, and the added energy needs time to move into the space. Total process lag is the sum of the individual lags encountered in the control process.

Measurement Lag

Dynamic error, static error, reproducibility, and dead zone all contribute to measurement lag. Because a sensing element cannot measure changes in the controlled variable instantly, dynamic error occurs and is an important factor in control. Dynamic error is the difference between the true and the measured value of a variable and is always present when the controlled variable changes. The variable usually fluctuates around the control point because system operating conditions are rarely static. The difference is caused by the mass of the sensing element and is most pronounced in temperature and humidity control systems. The greater the mass, the greater the difference when conditions are changing. Pressure sensing involves little dynamic error.

Static error is the deviation between a measured value and the true value of the static variable. Static error can be caused by sensor calibration error. Static error is undesirable but not always detrimental to control.

Repeatability is the ability of a sensor or controller to output the same signal when it measures the same value of a variable or load at different times. Precise control requires a high degree of reproducibility.

The difference between repeatability and static error is that repeatability is the ability to return to a specific condition, whereas static error is a constant deviation from that condition. Static error (e.g., sensor error) does not interfere with the ability to control, but requires that the control point be shifted to compensate and maintain a desired value.

The dead zone is a range through which the controlled variable changes without the controller initiating a correction. The dead zone effect creates an offset or a delay in providing the initial signal to the controller. The more slowly the variable changes, the more critical the dead zone becomes.

Capacitance

Capacitance differs from capacity. Capacity is determined by the energy output the system is capable of producing; capacitance relates to the mass of the system. For example, for a given heat input, it takes longer to raise the temperature of a liter of water one degree than a liter of air. When the heat source is removed, the air cools off more quickly than the water. Thus the capacitance of the water is much greater than the capacitance of air.

A capacitance that is large relative to the control agent tends to keep the controlled variable constant despite load changes. However, the large capacitance makes changing the variable to a new value more difficult. Although a large capacitance generally improves control, it introduces lag between the time a change is made in the control agent and the time the controlled variable reflects the change.

Figure 44 shows heat applied to a storage tank containing a large volume of liquid. The process in Figure 44 has a large thermal capacitance. The mass of the liquid in the tank exerts a stabilizing effect and does not immediately react to changes such as variations in the rate of the flow of steam or liquid, minor variations in the heat input, and sudden changes in the ambient temperature.

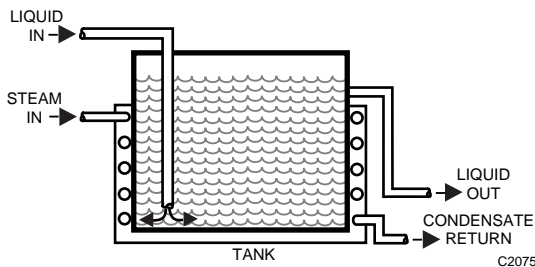

Fig. 44. Typical Process with Large Thermal Capacitance.

Figure 45 shows a high-velocity heat exchanger, which represents a process with a small thermal capacitance. The rate of flow for the liquid in Figure 45 is the same as for the liquid in Figure 44. However, in Figure 45 the volume and mass of the liquid in the tube at any one time is small compared to the tank shown in Figure 44. In addition, the total volume of liquid in the exchanger at any time is small compared to the rate of flow, the heat transfer area, and the heat supply. Slight variations in the rate of feed or rate of heat supply show up immediately as fluctuations in the temperature of the liquid leaving the exchanger. Consequently, the process in Figure 45 does not have a stabilizing influence but can respond quickly to load changes.

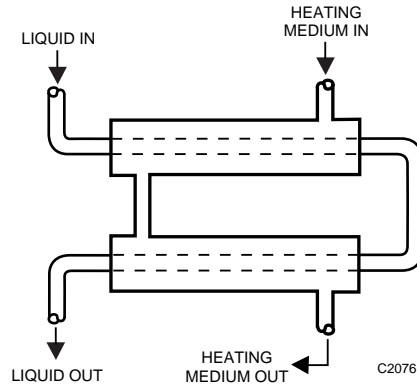
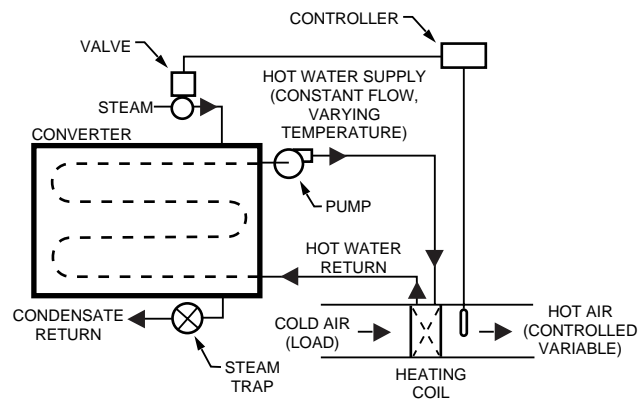

Fig. 45. Typical Process with Small Thermal Capacitance.

Figure 46 shows supply capacitance in a steam-to-water converter. When the load on the system (in Figure 44, cold air) increases, air leaving the heating coil is cooler. The controller senses the drop in temperature and calls for more steam to the converter. If the water side of the converter is large, it takes longer for the temperature of the supply water to rise than if the converter is small because a load change in a process with a large supply capacitance requires more time to change the variable to a new value.



C2077

Fig. 46. Supply Capacitance (Heating Application).

In terms of heating and air conditioning, a large office area containing desks, file cabinets, and office machinery has more capacitance than the same area without furnishings. When the temperature is lowered in an office area over a weekend, the furniture loses heat. It takes longer to heat the space to the comfort level on Monday morning than it does on other mornings when the furniture has not had time to lose as much heat. If the area had no furnishings, it would heat up much more quickly.

The time effect of capacitance determines the process reaction rate, which influences the corrective action that the controller takes to maintain process balance.

Resistance

Resistance applies to the parts of the process that resist the energy (or material) transfer. Many processes, especially those involving temperature control, have more than one capacitance. The flow of energy (heat) passing from one capacitance through a resistance to another capacitance causes a transfer lag (Fig. 47).

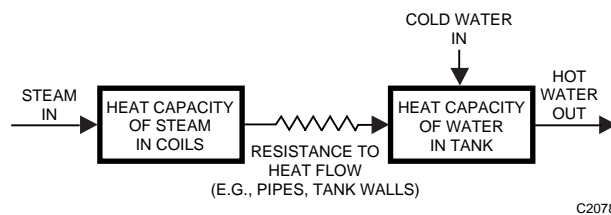

Fig. 47. Schematic of Heat Flow Resistance.

A transfer lag delays the initial reaction of the process. In temperature control, transfer lag limits the rate at which the heat input affects the controlled temperature. The controller tends to overshoot the setpoint because the effect of the added heat is not felt immediately and the controller calls for still more heat.

The office described in the previous example is comfortable by Monday afternoon and appears to be at control point. However, the paper in the middle of a full file drawer would still be cold because paper has a high thermal resistance. As a result, if the heat is turned down 14 hours a day and is at comfort level 10 hours a day, the paper in the file drawer will never reach room temperature.

An increase in thermal resistance increases the temperature difference and/or flow required to maintain heat transfer. If the fins on a coil become dirty or corroded, the resistance to the transfer of heat from one medium to the other medium increases.

Dead Time

Dead time, which is also called “transportation lag”, is the delay between two related actions in a continuous process where flow over a distance at a certain velocity is associated with energy transfer. Dead time occurs when the control valve or sensor is installed at a distance from the process (Fig. 48).

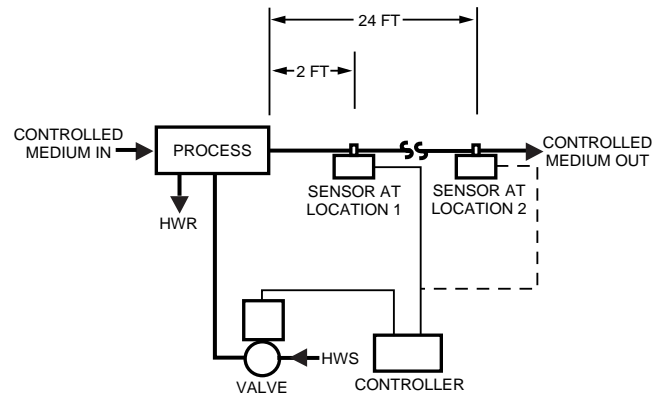

VELOCITY OF CONTROLLED MEDIUM: 12 FT/S
 DEAD TIME FOR SENSOR AT LOCATION 1: $\frac{2 \text{ FT}}{12 \text{ FT/S}} = 0.166 \text{ SEC}$
 DEAD TIME FOR SENSOR AT LOCATION 2: $\frac{24 \text{ FT}}{12 \text{ FT/S}} = 2.0 \text{ SEC}$

Fig. 48. Effect of Location on Dead Time.

Dead time does not change the process reaction characteristics, but instead delays the process reaction. The delay affects the system dynamic behavior and controllability, because the controller cannot initiate corrective action until it sees a deviation. Figure 48 shows that if a sensor is 8 meters away from a process, the controller that changes the position of the valve requires two seconds to see the effect of that change, even assuming negligible capacitance, transfer, and measurement lag. Because dead time has a significant effect on system control, careful selection and placement of sensors and valves is required to maintain system equilibrium.

CONTROL APPLICATION GUIDELINES

The following are considerations when determining control requirements:

- The degree of accuracy required and the amount of offset, if any, that is acceptable.
- The type of load changes expected, including their size, rate, frequency, and duration.
- The system process characteristics, such as time constants, number of time lag elements, and reaction rate.

Each control mode is applicable to processes having certain combinations of the basic characteristics. The simplest mode of control that meets application requirements is the best mode to use, both for economy and for best results. Using a control mode that is too complicated for the application may result in

poor rather than good control. Conversely, using a control mode that is too basic for requirements can make adequate control impossible. Table 3 lists typical control applications and recommended control modes.

Table 3. Control Applications and Recommended Control Modes.

Control Application	Recommended Control Mode ^a
Space Temperature	P, PID
Mixed Air Temperature	PI, EPID
Coil Discharge Temperature	PI, EPID
Chiller Discharge Temperature	PI, EPID
Hot Water Converter Discharge Temperature	PI, EPID
Airflow	PI Use a wide proportional band and a fast reset rate. For some applications, PID may be required.
Fan Static Pressure	PI, EPID
Humidity	P, or if very tight control is required, PI
Dewpoint Temperature	P, or if very tight control is required, PI

^a PID, EPID control is used in digital systems.

CONTROL SYSTEM COMPONENTS

Control system components consist of sensing elements, controllers, actuators, and auxiliary equipment.

SENSING ELEMENTS

A sensing element measures the value of the controlled variable. Controlled variables most often sensed in HVAC systems are temperature, pressure, relative humidity, and flow.

TEMPERATURE SENSING ELEMENTS

The sensing element in a temperature sensor can be a bimetal strip, a rod-and-tube element, a sealed bellows, a sealed bellows attached to a capillary or bulb, a resistive wire, or a thermistor. Refer to the Electronic Control Fundamentals section of this manual for Electronic Sensors for Microprocessor Based Systems.

A bimetal element is a thin metallic strip composed of two layers of different kinds of metal. Because the two metals have different rates of heat expansion, the curvature of the bimetal changes with changes in temperature. The resulting movement of the bimetal can be used to open or close circuits in electric control systems or regulate airflow through nozzles in pneumatic control systems. Winding the bimetal in a coil (Fig. 49) enables a greater length of the bimetal to be used in a limited space.

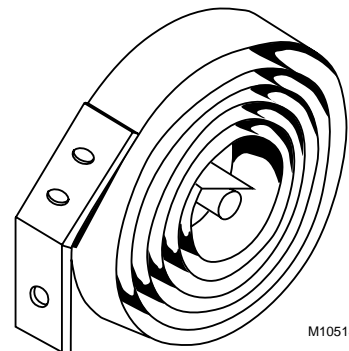
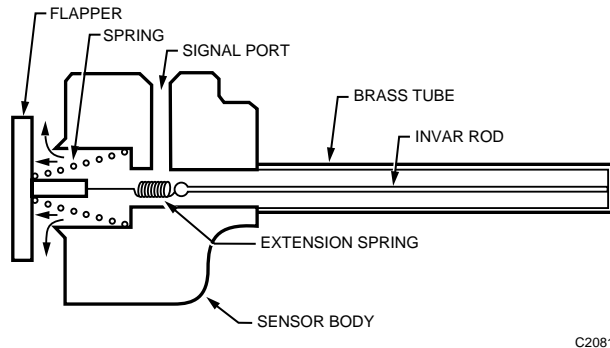

Fig. 49. Coiled Bimetal Element.

The rod-and-tube element (Fig. 50) also uses the principle of expansion of metals. It is used primarily for insertion directly into a controlled medium, such as water or air. In a typical pneumatic device, a brass tube contains an Invar rod which is fastened at one end to the tube and at the other end to a spring and flapper. Brass has the higher expansion coefficient and is placed outside to be in direct contact with the measured medium. Invar does not expand noticeably with temperature changes. As the brass tube expands lengthwise, it pulls the Invar rod with it and changes the force on the flapper. The flapper is used to generate a pneumatic signal. When the flapper position changes, the signal changes correspondingly.



C2081

Fig. 50. Rod-and-Tube Element.

In a remote-bulb controller (Fig. 51), a remote capsule, or bulb, is attached to a bellows housing by a capillary. The remote bulb is placed in the controlled medium where changes in temperature cause changes in pressure of the fill. The capillary transmits changes in fill pressure to the bellows housing and the bellows expands or contracts to operate the mechanical output to the controller. The bellows and capillary also sense temperature, but because of their small volume compared to the bulb, the bulb provides the control.

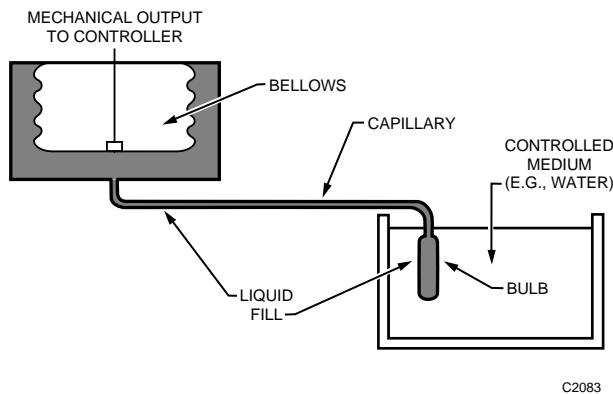

C2083

Fig. 51. Typical Remote-Bulb Element.

Two specialized versions of the remote bulb controller are available. They both have no bulb and use a long capillary (4.5 to 8.5 meters) as the sensor. One uses an averaging sensor that is liquid filled and averages the temperature over the full length of the capillary. The other uses a cold spot or low temperature sensor and is vapor filled and senses the coldest spot (300 mm or more) along its length.

Electronic temperature controllers use low-mass sensing elements that respond quickly to changes in the controlled condition. A signal sent by the sensor is relatively weak, but is amplified to a usable strength by an electronic circuit.

The temperature sensor for an electronic controller may be a length of wire or a thin metallic film (called a resistance temperature device or RTD) or a thermistor. Both types of resistance elements change electrical resistance as temperature changes. The wire increases resistance as its temperature increases. The thermistor is a semiconductor that decreases in resistance as the temperature increases.

Because electronic sensors use extremely low mass, they respond to temperature changes more rapidly than bimetal or sealed-fluid sensors. The resistance change is detected by a bridge circuit. Nickel "A", BALCO, and platinum are typical materials used for this type of sensor.

In thermocouple temperature-sensing elements, two dissimilar metals (e.g., iron and nickel, copper and constantan, iron and constantan) are welded together. The junction of the two metals produces a small voltage when exposed to heat. Connecting two such junctions in series doubles the generated voltage. Thermocouples are used primarily for high-temperature applications.

Many special application sensors are available, including carbon dioxide sensors and photoelectric sensors used in security, lighting control, and boiler flame safeguard controllers.

PRESSURE SENSING ELEMENTS

Pressure sensing elements respond to pressure relative to a perfect vacuum (absolute pressure sensors), atmospheric pressure (gage pressure sensors), or a second system pressure (differential pressure sensors), such as across a coil or filter. Pressure sensors measure pressure in a gas or liquid in kilopascals (kPa). Low pressures are typically measured in pascals (Pa). Pressure can be generated by a fan, a pump or compressor, a boiler, or other means.

Pressure controllers use bellows, diaphragms, and a number of other electronic pressure sensitive devices. The medium under pressure is transmitted directly to the device, and the movement of the pressure sensitive device operates the mechanism of a pneumatic or electric switching controller. Variations of the pressure control sensors measure rate of flow, quantity of flow, liquid level, and static pressure. Solid state sensors may use the piezoresistive effect in which increased pressure on silicon crystals causes resistive changes in the crystals.

MOISTURE SENSING ELEMENTS

Elements that sense relative humidity fall generally into two classes: mechanical and electronic. Mechanical elements expand and contract as the moisture level changes and are called “hygroscopic” elements. Several hygroscopic elements can be used to produce mechanical output, but nylon is the most commonly used element (Fig. 52). As the moisture content of the surrounding air changes, the nylon element absorbs or releases moisture, expanding or contracting, respectively. The movement of the element operates the controller mechanism.

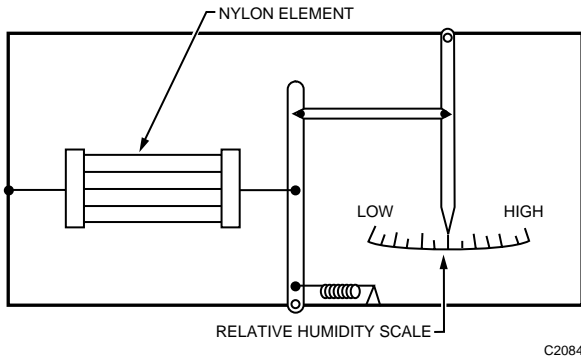

Fig. 52. Typical Nylon Humidity Sensing Element.

Electronic sensing of relative humidity is fast and accurate. An electronic relative humidity sensor responds to a change in humidity by a change in either the resistance or capacitance of the element.

If the moisture content of the air remains constant, the relative humidity of the air increases as temperature decreases and decreases as temperature increases. Humidity sensors also respond to changes in temperature. If the relative humidity is held constant, the sensor reading can be affected by temperature changes. Because of this characteristic, humidity sensors should not be used in atmospheres that experience wide temperature variations unless temperature compensation is provided. Temperature compensation is usually provided with nylon elements and can be factored into electronic sensor values, if required.

Dew point is the temperature at which vapor condenses. A dew point sensor senses dew point directly. A typical sensor uses a heated, permeable membrane to establish an equilibrium condition in which the dry-bulb temperature of a cavity in the sensor is proportional to the dew point temperature of the ambient air. Another type of sensor senses condensation on a cooled surface. If the ambient dry-bulb and dew point temperature are known, the relative humidity, total heat, and specific humidity can be calculated. Refer to the Psychrometric Chart Fundamentals section of this manual.

FLOW SENSORS

Flow sensors sense the rate of liquid and gas flow in volume per unit of time. Flow is difficult to sense accurately under all conditions. Selecting the best flow-sensing technique for an application requires considering many aspects, especially the level of accuracy required, the medium being measured, and the degree of variation in the measured flow.

A simple flow sensor is a vane or paddle inserted into the medium (Fig. 53) and generally called a flow switch. The paddle is deflected as the medium flows and indicates that the medium is in motion and is flowing in a certain direction. Vane or paddle flow sensors are used for flow indication and interlock purposes (e.g., a system requires an indication that water is flowing before the system starts the chiller).

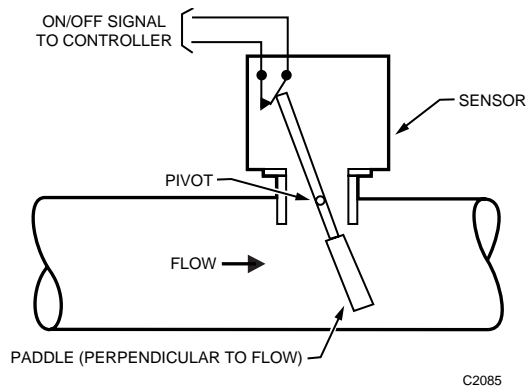

Fig. 53. Paddle Flow Sensor.

Flow meters measure the rate of fluid flow. Principle types of flow meters use orifice plates or vortex nozzles which generate pressure drops proportional to the square of fluid velocity. Other types of flow meters sense both total and static pressure, the difference of which is velocity pressure, thus providing a differential pressure measurement. Paddle wheels and turbines respond directly to fluid velocity and are useful over wide ranges of velocity.

In a commercial building or industrial process, flow meters can measure the flow of steam, water, air, or fuel to enable calculation of energy usage needs.

Airflow pickups, such as a pitot tube or flow measuring station (an array of pitot tubes), measure static and total pressures in a duct. Subtracting static pressure from total pressure yields velocity pressure, from which velocity can be calculated. Multiplying the velocity by the duct area yields flow. For additional information, refer to the Building Airflow System Control Applications section of this manual.

Applying the fluid jet principle allows the measurement of very small changes in air velocity that a differential pressure sensor cannot detect. A jet of air is emitted from a small tube perpendicular to the flow of the air stream to be measured. The impact of the jet on a collector tube a short distance away causes a positive pressure in the collector. An increase in velocity of the air stream perpendicular to the jet deflects the jet and decreases pressure in the collector. The change in pressure is linearly proportional to the change in air stream velocity.

Another form of air velocity sensor uses a microelectronic circuit with a heated resistance element on a microchip as the primary velocity sensing element. Comparing the resistance of this element to the resistance of an unheated element indicates the velocity of the air flowing across it.

PROOF-OF-OPERATION SENSORS

Proof-of-operation sensors are often required for equipment safety interlocks, to verify command execution, or to monitor fan and pump operation status when a central monitoring and management system is provided. Current-sensing relays, provided with current transformers around the power lines to the fan or pump motor, are frequently used for proof-of-operation inputs. The contact closure threshold should be set high enough for the relay to drop out if the load is lost (broken belt or coupling) but not so low that it drops out on a low operational load.

Current-sensing relays are reliable, require less maintenance, and cost less to install than mechanical duct and pipe devices.

TRANSDUCERS

Transducers convert (change) sensor inputs and controller outputs from one analog form to another, more usable, analog form. A voltage-to-pneumatic transducer, for example, converts a controller variable voltage input, such as 2 to 10 volts, to a linear variable pneumatic output, such as 20 to 100 kPa. The pneumatic output can be used to position devices such as a pneumatic valve or damper actuator. A pressure-to-voltage transducer converts a pneumatic sensor value, such as 15 to 100 kPa, to a voltage value, such as 2 to 10 volts, that is acceptable to an electronic or digital controller.

CONTROLLERS

Controllers receive inputs from sensors. The controller compares the input signal with the desired condition, or setpoint, and generates an output signal to operate a controlled device. A sensor may be integral to the controller (e.g., a thermostat) or some distance from the controller.

Controllers may be electric/electronic, microprocessor, or pneumatic. An electric/electronic controller provides two-position, floating, or modulating control and may use a mechanical sensor input such as a bimetal or an electric input such as a resistance element or thermocouple. A microprocessor controller uses digital logic to compare input signals with the desired result and computes an output signal using equations or algorithms programmed into the controller. Microprocessor controller inputs can be analog or on/off signals representing sensed variables. Output signals may be on/off, analog, or pulsed. A pneumatic controller receives input signals from a pneumatic sensor and outputs a modulating pneumatic signal.

ACTUATORS

An actuator is a device that converts electric or pneumatic energy into a rotary or linear action. An actuator creates a change in the controlled variable by operating a variety of final control devices such as valves and dampers.

In general, pneumatic actuators provide proportioning or modulating action, which means they can hold any position in their stroke as a function of the pressure of the air delivered to them. Two-position or on/off action requires relays to switch from zero air pressure to full air pressure to the actuator.

Electric control actuators are two-position, floating, or proportional (refer to CONTROL MODES). Electronic actuators are proportional electric control actuators that require an electronic input. Electric actuators are bidirectional, which means they rotate one way to open the valve or damper, and the other way to close the valve or damper. Some electric actuators require power for each direction of travel. Pneumatic and some electric actuators are powered in one direction and store energy in a spring for return travel.

Figure 54 shows a pneumatic actuator controlling a valve. As air pressure in the actuator chamber increases, the downward force (F1) increases, overcoming the spring compression force (F2), and forcing the diaphragm downward. The downward movement of the diaphragm starts to close the valve. The valve thus reduces the flow in some proportion to the air pressure applied by the actuator. The valve in Figure 54 is fully open with zero air pressure and the assembly is therefore normally open.

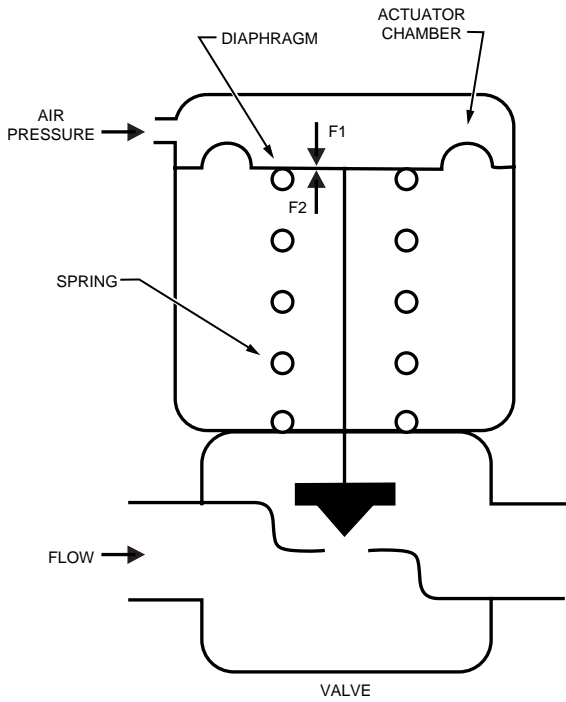

C2086

Fig. 54. Typical Pneumatic Valve Actuator.

A pneumatic actuator similarly controls a damper. Figure 55 shows pneumatic actuators controlling normally open and normally closed dampers.

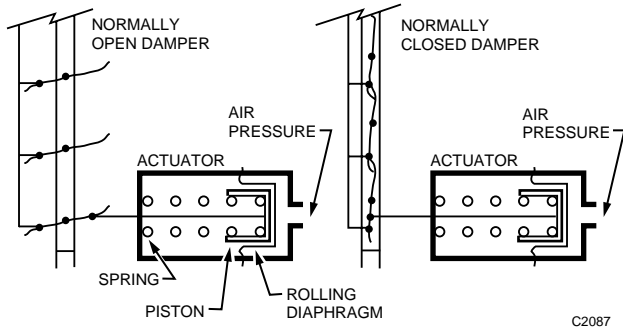

C2087

Fig. 55. Typical Pneumatic Damper Actuator.

Electric actuators are inherently positive positioning. Some pneumatic control applications require accurate positioning of the valve or damper. For pneumatic actuators, a positive positioning relay is connected to the actuator and ensures that the actuator position is proportional to the control signal. The positive positioning relay receives the controller output signal, reads the actuator position, and repositions the actuator according to the controller signal, regardless of external loads on the actuator.

Electric actuators can provide proportional or two-position control action. Figure 56 shows a typical electric damper actuator. Spring-return actuators return the damper to either the closed or the open position, depending on the linkage, on a power interruption.

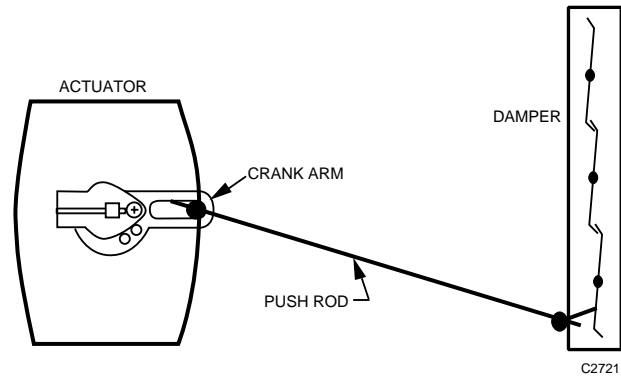

C2721

Fig. 56. Typical Electric Damper Actuator.

AUXILIARY EQUIPMENT

Many control systems can be designed using only a sensor, controller, and actuator. In practice, however, one or more auxiliary devices are often necessary.

Auxiliary equipment includes transducers to convert signals from one type to another (e.g., from pneumatic to electric), relays and switches to manipulate signals, electric power and compressed air supplies to power the control system, and indicating devices to facilitate monitoring of control system activity.

CHARACTERISTICS AND ATTRIBUTES OF CONTROL METHODS

Review the columns of Table 4 to determine the characteristics and attributes of pneumatic, electric, electronic, and microprocessor control methods.

Table 4. Characteristics and Attributes of Control Methods.

Pneumatic	Electric	Electronic	Microprocessor
Naturally proportional	Most common for simple on-off control	Precise control	Precise control
Requires clean dry air	Integral sensor/controller	Solid state repeatability and reliability	Inherent energy management
Air lines may cause trouble below freezing	Simple sequence of control	Sensor may be up to 300 feet from controller	Inherent high order (proportional plus integral) control, no undesirable offset
Explosion proof	Broad environmental limits	Simple, remote, rotary knob setpoint	Compatible with building management system. Inherent database for remote monitoring, adjusting, and alarming.
Simple, powerful, low cost, and reliable actuators for large valves and dampers	Complex modulating actuators, especially when spring-return	High per-loop cost	Easily performs a complex sequence of control
Simplest modulating control		Complex actuators and controllers	Global (inter-loop), hierarchial control via communications bus (e.g., optimize chillers based upon demand of connected systems)
			Simple remote setpoint and display (absolute number, e.g., 74.4)
			Can use pneumatic actuators

Psychrometric Chart Fundamentals

ENGINEERING MANUAL OF AUTOMATIC CONTROL

CONTENTS

Introduction	38
Definitions	38
Description of the Psychrometric Chart	39
The Abridged Psychrometric Chart	40
Examples of Air Mixing Process	42
Air Conditioning Processes	43
Heating Process	43
Cooling Process	44
Humidifying Process	44
Basic Process	44
Steam Jet Humidifier	46
Air Washers	49
Vaporizing Humidifier	50
Cooling and Dehumidification	51
Basic Process	51
Air Washers	51
Dehumidification and Reheat	52
Process Summary	53
ASHRAE Psychrometric Charts	53

INTRODUCTION

This section provides information on use of the psychrometric chart as applied to air conditioning processes. The chart provides a graphic representation of the properties of moist air including wet- and dry-bulb temperature, relative humidity, dew point, moisture content, enthalpy, and air density. The chart is used to plot the changes that occur in the air as it passes through an air handling system and is particularly useful in understanding these

changes in relation to the performance of automatic HVAC control systems. The chart is also useful in troubleshooting a system.

For additional information about control of the basic processes in air handling systems, refer to the Air Handling System Control Applications section.

DEFINITIONS

To use these charts effectively, terms describing the thermodynamic properties of moist air must be understood. Definition of these terms follow as they relate to the psychrometric chart. Additional terms are included for devices commonly used to measure the properties of air.

Adiabatic process: A process in which there is neither loss nor gain of total heat. The heat merely changes from sensible to latent or latent to sensible.

Density: The mass of air per unit volume. Density can be expressed in kilograms per cubic meter of dry air. This is the reciprocal of specific volume.

Dew point temperature: The temperature at which water vapor from the air begins to form droplets and settles or condenses on surfaces that are colder than the dew point of the air. The more moisture the air contains, the higher its dew point temperature. When dry-bulb and wet-bulb temperatures of the air are known, the dew point temperature can be plotted on the psychrometric chart (Fig. 4).

Dry-bulb temperature: The temperature read directly on an ordinary thermometer.

Isothermal process: A process in which there is no change of dry-bulb temperature.

Joule (J): The unit of measure for energy, work, and heat. This section uses joule as a unit of heat where 4.2 joules will raise the temperature of 1 gram of water 1 kelvin.

Latent heat: Heat that changes liquid to vapor or vapor to liquid without a change in temperature or pressure of the moisture. Latent heat is also called the heat of vaporization or condensation. When water is vaporized, it absorbs heat which becomes latent heat. When the vapor condenses, latent heat is released, usually becoming sensible heat.

Moisture content (humidity ratio): The amount of water contained in a unit mass of dry air.

Relative humidity: The ratio of the measured amount of moisture in the air to the maximum amount of moisture the air can hold at the same temperature and pressure. Relative humidity is expressed in percent of saturation. Air with a relative humidity of 35, for example, is holding 35 percent of the moisture that it is capable of holding at that temperature and pressure.

Saturation: A condition at which the air is unable to hold any more moisture at a given temperature.

Sensible heat: Heat that changes the temperature of the air without changing its moisture content. Heat added to air by a heating coil is an example of sensible heat.

Sling psychrometer: A device (Fig. 1) commonly used to measure the wet-bulb temperature. It consists of two identical thermometers mounted on a common base. The base is pivoted on a handle so it can be whirled through the air. One thermometer measures dry-bulb temperature. The bulb of the other thermometer is encased in a water-soaked wick. This thermometer measures wet-bulb temperature. Some models provide slide rule construction which allows converting the dry-bulb and wet-bulb readings to relative humidity.

Although commonly used, sling psychrometers can cause inaccurate readings, especially at low relative humidities, because of factors such as inadequate air flow past the wet-bulb wick, too much wick wetting from a continuous water feed, thermometer calibration error, and human error. To take more accurate readings, especially in low relative humidity conditions, motorized psychrometers or hand held electronic humidity sensors are recommended.

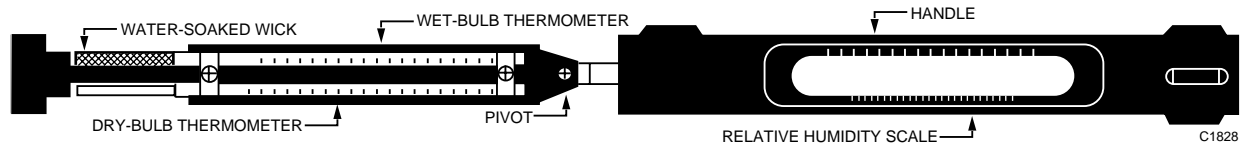

Fig. 1. Sling Psychrometer.

Specific volume: The volume of air per unit of mass. Specific volume can be expressed in cubic meters per kilogram of dry air. The reciprocal of density.

Total heat (also termed enthalpy): The sum of sensible and latent heat expressed in Kilojoule per unit of mass of the air. Total heat, or enthalpy, is usually measured from zero degrees Celsius for air. These values are shown on the ASHRAE Psychrometric Charts in Figures 33 and 34.

Wet-bulb temperature: The temperature read on a thermometer with the sensing element encased in a wet wick

(stocking or sock) and with an air flow of 4.57 meters per second across the wick. Water evaporation causes the temperature reading to be lower than the ambient dry-bulb temperature by an amount proportional to the moisture content of the air. The temperature reduction is sometimes called the evaporative effect. When the reading stops falling, the value read is the wet-bulb temperature.

The wet-bulb and dry-bulb temperatures are the easiest air properties to measure. When they are known, they can be used to determine other air properties on a psychrometric chart.

DESCRIPTION OF THE PSYCHROMETRIC CHART

The ASHRAE Psychrometric Chart is a graphical representation of the thermodynamic properties of air. There are five different psychrometric charts available and in use today:

- Chart No. 1 — Normal temperatures, 0 to 50°C
- Chart No. 2 — Low temperatures, -40 to 10°C
- Chart No. 3 — High temperatures, 10 to 120°C
- Chart No. 4 — Very High temperatures, 100 to 200°C
- Chart No. 5 — Normal temperature at 750 meters above sea level, 0 to 50°C
- Chart No. 6 — Normal temperature at 1500 meters above sea level, 0 to 50°C
- Chart No. 7 — Normal temperature at 2250 meters above sea level, 0 to 50°C

Chart No. 1 can be used alone when no freezing temperatures are encountered. Chart No. 2 is very useful, especially in locations with colder temperatures. To apply the lower range chart to an HVAC system, part of the values are plotted on Chart No. 2 and the resulting information transferred to Chart No. 1. This is discussed in the EXAMPLES OF AIR MIXING PROCESS section. These two charts allow working within the comfort range of most systems. Copies are provided in the ASHRAE PSYCHROMETRIC CHARTS section.

THE ABRIDGED PSYCHROMETRIC CHART

Figure 2 is an abridged form of Chart No. 1. Some of the scale lines have been removed to simplify illustrations of the psychrometric processes. Smaller charts are used in most of the subsequent examples. Data in the examples is taken from full-scale charts

The major lines and scales on the abridged psychrometric chart identified in bold letters are:

- Dry-bulb temperature lines
- Wet-bulb temperature lines
- Enthalpy or total heat lines
- Relative humidity lines
- Humidity ratio or moisture content lines
- Saturation temperature or dew point scale
- Volume lines in cubic meters per kilogram of dry air

The chart also contains a protractor nomograph with the following scales:

- Enthalpy/humidity ratio scale
- Sensible heat/total heat ratio scale

When lines are drawn on the chart indicating changes in psychrometric conditions, they are called process lines.

With the exception of relative humidity, all lines are straight. Wet-bulb lines and enthalpy (total heat) lines are not exactly the same so care must be taken to follow the correct line. The dry-bulb lines are not necessarily parallel to each other and incline slightly from the vertical position. The purpose of the two enthalpy scales (one on the protractor and one on the chart) is to provide reference points when drawing an enthalpy (total

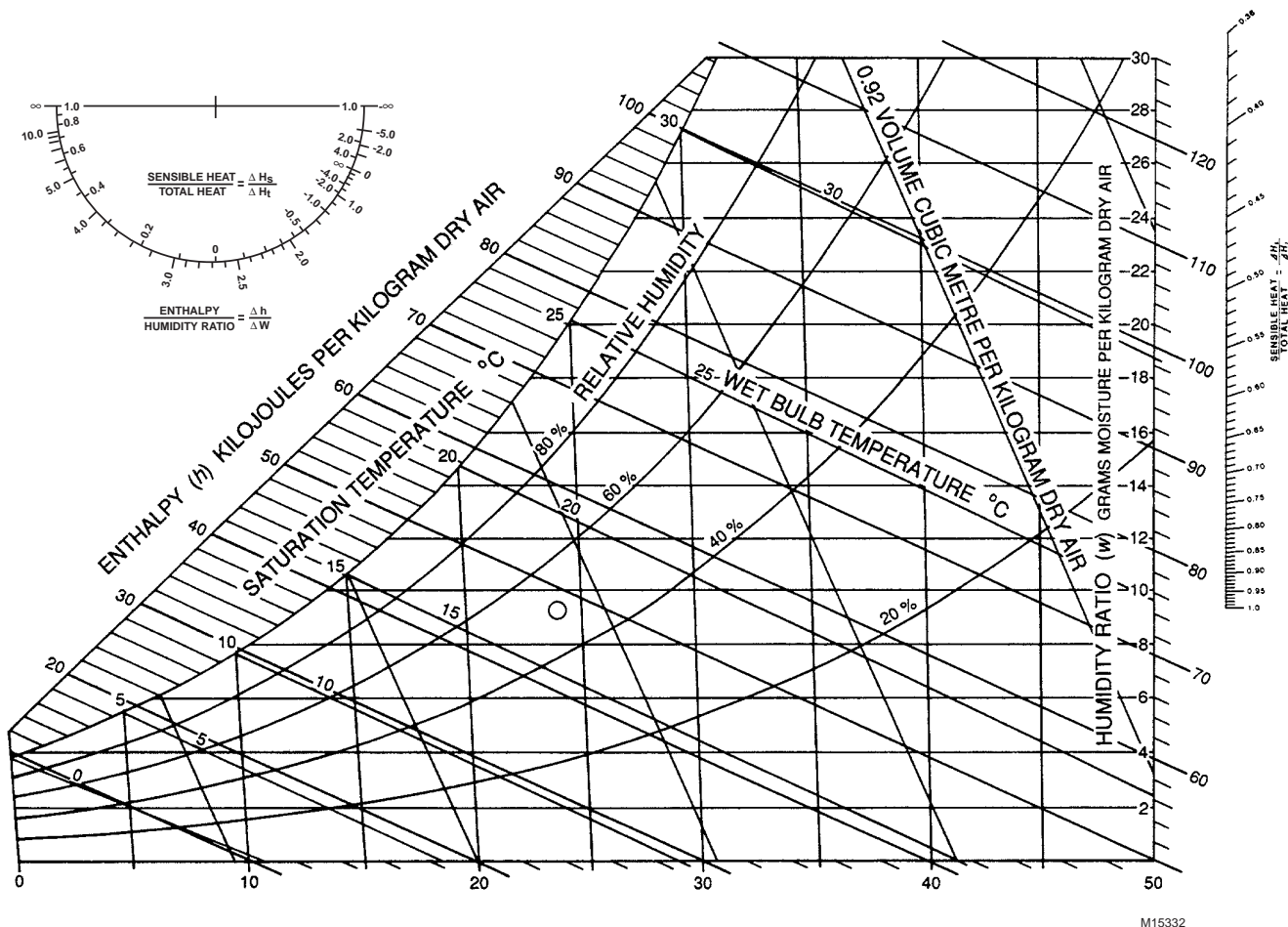

Fig. 2. Abridged Chart No. 1.

heat) line. The protractor nomograph, in the upper left corner, is used to establish the slope of a process line. The mechanics of constructing this line are discussed in more detail in the STEAM JET HUMIDIFIERS section.

The various properties of air can be determined from the chart whenever the lines of any two values cross even though all properties may not be of interest. For example, from the point where the 21°C dry-bulb and 15.5°C wet-bulb lines cross (Fig. 3, Point A), the following additional values can be determined:

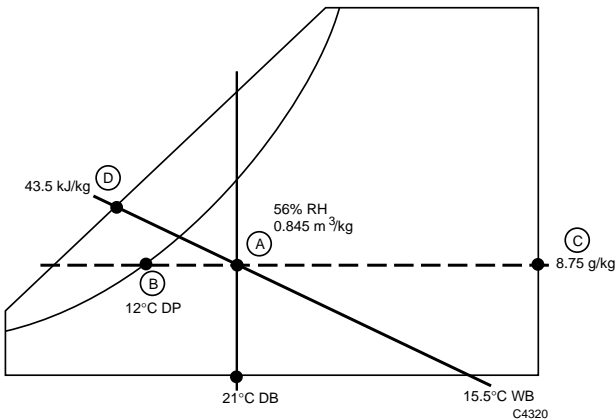

Fig. 3.

- Relative humidity is 56 percent (Point A)
- Volume is 0.845 cubic meters per kilogram of dry air (Point A)
- Dew point is 12°C (Point B)
- Moisture content is 8.75 grams of moisture per kilogram of dry air (Point C)
- Enthalpy (total heat) is 43.5 kilojoules per kilogram of dry air (Point D)
- Density is 1.163 kilograms per cubic meter (reciprocal of volume)

Figure 4 is another plotting example. This time the dry-bulb temperature line and relative humidity line are used to establish the point. With the relative humidity equal to 60 percent and the dry-bulb temperature at 25°C (Fig. 4, Point A), the following values can be read:

- Wet-bulb temperature is 19.5°C (Point A)
- Volume is 0.86 cubic meters per kilogram of dry air (Point A)
- Dew point is 17°C (Point B)
- Moisture content is 12.0 grams of moisture per kilogram of dry air (Point C)

- Enthalpy is 56.0 kilojoules per kilogram of dry air (Point D)
- Density is 1.163 kilograms per cubic meter (reciprocal of volume)

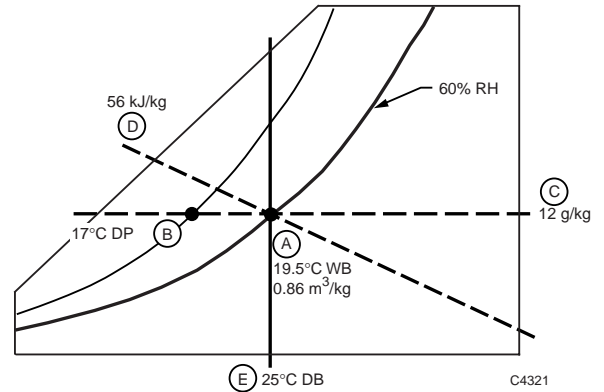

Fig. 4.

Figure 5 is the same as Figure 4 but is used to obtain latent heat and sensible heat values. Figures 4 and 5 indicate that the enthalpy (total heat) of the air is 56.0 kilojoules per kilogram of dry air (Point D). Enthalpy is the sum of sensible and latent heat (Line A to E + Line E to D, Fig. 5). The following process determines how much is sensible heat and how much is latent heat. The bottom horizontal line of the chart represents zero moisture content. Project a constant enthalpy line to the enthalpy scale (from Point C to Point E). Point E enthalpy represents sensible heat of 25.5 kilojoules per kilogram of dry air. The difference between this enthalpy reading and the original enthalpy reading is latent heat. In this example 56.0 minus 25.5 equals 30.5 kilojoules per kilogram of dry air of latent heat. When the moisture content of the air changes but the dry-bulb temperature remains constant, latent heat is added or subtracted.

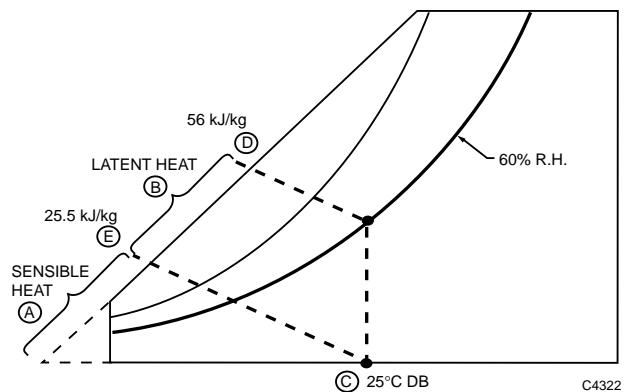

Fig. 5.

EXAMPLES OF AIR MIXING PROCESS

The following examples illustrate use of the psychrometric chart to plot values and determine conditions in a ventilating system. The examples also show how to obtain the same results by calculation. Example A requires only Chart No. 1. Example B requires both Charts No. 1 and 2 since the outdoor air temperature is in the range of Chart No. 2.

EXAMPLE A:

Plotting values where only Chart No. 1 (Fig. 6) is required.

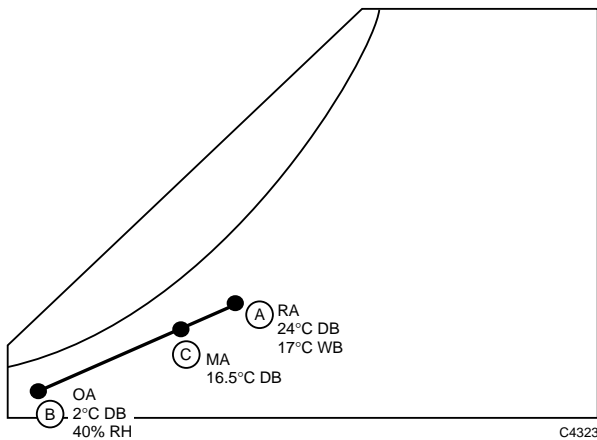

Fig. 6. Example A, Chart No. 1.

In this example:

1. A fixed quantity of two-thirds return air and one-third outdoor air is used.
2. The return air condition is 24°C dry bulb and 17°C wet bulb.
3. Outdoor air condition is 2°C dry bulb and 40 percent rh.

To find the mixed air conditions at design:

1. Plot the return air (RA) condition (Point A) and outdoor air (OA) condition (Point B).
2. Connect the two points with a straight line.
3. Calculate the mixed air dry-bulb temperature:
 $(2/3 \times 75) + (1/3 \times 36) = 16.5^\circ\text{C dry bulb}$
4. The mixed air conditions are read from the point at which the line, drawn in Step 2, intersects the 16.5°C dry-bulb line (Point C).

EXAMPLE B:

Plotting values when both Chart No. 1 and Chart No. 2 are required.

In this example, a ventilating system (Fig. 7) is used to illustrate how to plot data on Chart No. 2 and transfer values to Chart No. 1. Chart No. 2 is similar to Chart No. 1 except that it covers the -40°C to 10°C temperature range. This is the temperature range immediately below that of Chart No. 1. Note that there is an overlap of temperatures between 0°C and 10°C. The overlap is important when transferring values from one chart to another.

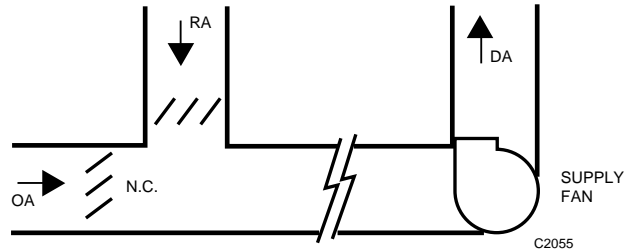

Fig. 7. Example B, Ventilating System.

This example illustrates mixing two different air conditions with no change in total heat (enthalpy). Any changes in the total heat required to satisfy space conditions are made by heating, cooling, humidification, or dehumidification after the air is mixed.

In this example:

1. A fixed quantity of two-thirds return air and one-third outdoor air is used.
2. The return air condition is 24°C dry bulb and 17°C wet bulb.
3. Outdoor air condition is -12°C dry bulb and 50 percent rh.

To find the mixed air condition:

1. Plot the outdoor air (OA) condition on Chart No. 2, Fig. 8
2. Plot the return air (RA) condition on Chart No. 1, Fig. 9.

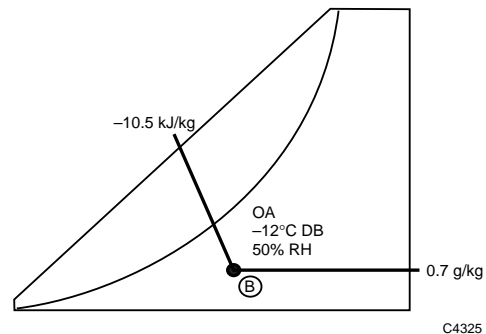

Fig. 8. Example B, Chart No. 2.

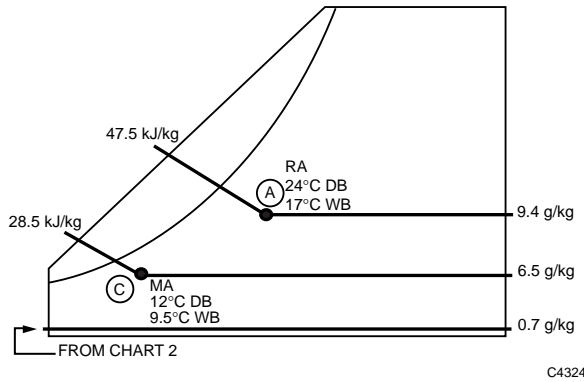

Fig. 9. Example B, Chart No. 1

3. Calculate the mixed air enthalpy as follows:

- For the return air, project a line parallel to the enthalpy line from Point A to the enthalpy scale on Figure 9. The value is 47.5 kilojoules per kilogram of dry air.
- For the outdoor air, project a line parallel to the enthalpy line from Point B to the enthalpy scale on Figure 8. The value is -10.5 kilojoules per kilogram of dry air.
- Using the determined values, calculate the mixed air enthalpy:

$$(2/3 \times 47.5) + (1/3 \times -10.5) = 28.2 \text{ kilojoules per kilogram of dry air}$$

- Calculate the mixed air moisture content as follows:
 - For the return air, project a line from Point A horizontally to the moisture content scale on Figure 9. The value is 9.4 grams of moisture per kilogram of dry air.
 - For the outdoor air, project a line from Point B horizontally to the moisture content scale on Figure 8. The value is 0.7 grams of moisture per kilogram of dry air. Also, project this value on to Chart No. 1 as shown in Figure 9.
 - Using the determined values, calculate the mixed air moisture content:

$$(2/3 \times 9.4) + (1/3 \times 0.7) = 6.5 \text{ grams of moisture per kilogram of dry air}$$

- Using the enthalpy value of 28.2 kJ/kg and the moisture content value of 6.5g, plot the mixed air conditions, Point C, on Chart No. 1, Figure 9, by drawing a horizontal line across the chart at the 6.5g moisture content level and a diagonal line parallel to the enthalpy lines starting at the 28.2 kilojoules per kilogram of dry air enthalpy point. Point C yields 12°C dry-bulb and 9.5°C wet-bulb temperature.
- Read other conditions for the mixed air (MA) from Chart No. 1 as needed.

AIR CONDITIONING PROCESSES

HEATING PROCESS

The heating process adds sensible heat to the system and follows a constant, horizontal moisture line. When air is heated by a steam or hot water coil, electric heat, or furnace, no moisture is added. Figure 10 illustrates a fan system with a heating coil. Figure 11 illustrates a psychrometric chart for this system. Air is heated from 13°C dry bulb to 30°C dry bulb represented by Line A-B. This is the process line for heating. The relative humidity drops from 40 percent to 12 percent and the moisture content remains 3.8 grams of moisture per kilogram of air. Determine the total heat added as follows:

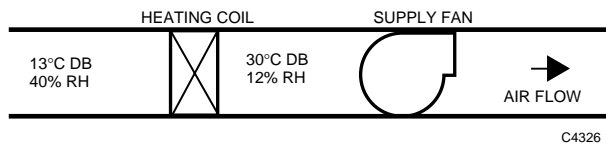

Fig. 10. Fan System with Heating Coil.

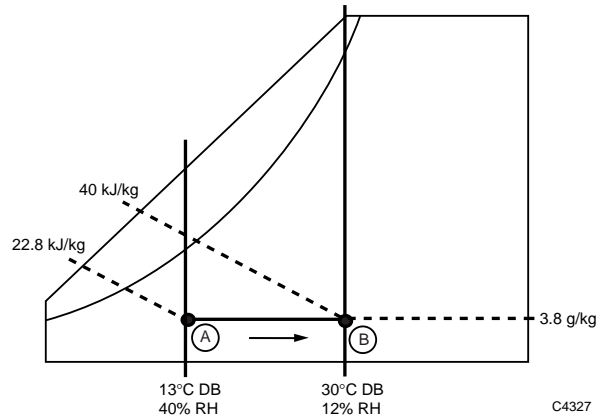

Fig. 11.

1. Draw diagonal lines parallel to the constant enthalpy lines from Points A and B to the enthalpy scale.
2. Read the enthalpy on the enthalpy scale.
3. Calculate the enthalpy added as follows:

$$\text{Total heat at Point B} - \text{total heat at Point A} = \text{total heat added.}$$

$$40.0 - 22.8 = 17.2 \text{ kilojoules per kilogram of dry air}$$

Since there is no change in moisture content, the total heat added is all sensible. Whenever the process moves along a constant moisture line, only sensible heat is changed.

COOLING PROCESS

The cooling process removes sensible heat and, often, latent heat from the air. Consider a condition where only sensible heat is removed. Figure 12 illustrates a cooling process where air is cooled from 32°C to 21°C but no moisture is removed. Line A-B represents the process line for cooling. The relative humidity in this example increases from 50 percent (Point A) to 95 percent (Point B) because air at 21°C cannot hold as much moisture as air at 32°C. Consequently, the same amount of moisture results in a higher percentage relative humidity at 21°C than at 32°C. Calculate the total heat removed as follows:

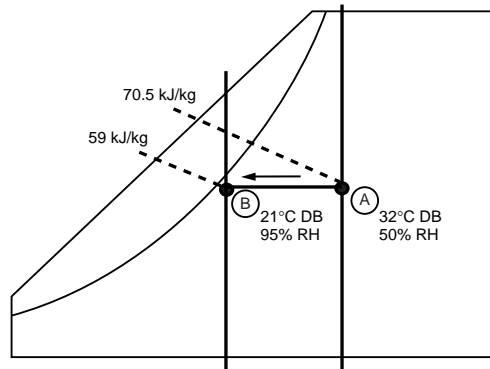
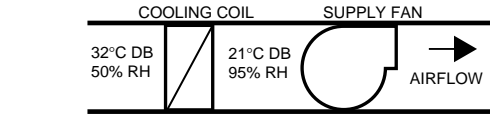

C4328

Fig. 12.

$$\text{Total heat at Point A} - \text{total heat at Point B} = \text{total heat removed.}$$

$$70.5 - 59.0 = 11.5 \text{ kilojoules per kilogram of dry air}$$

This is all sensible heat since there is no change in moisture content.

HUMIDIFYING PROCESS

BASIC PROCESS

The humidifying process adds moisture to the air and crosses constant moisture lines. If the dry bulb remains constant, the process involves the addition of latent heat only.

Relative humidity is the ratio of the amount of moisture in the air to the maximum amount of moisture the air can hold at the same temperature and pressure. If the dry-bulb temperature increases without adding moisture, the relative humidity decreases. The psychrometric charts in Figures 13 and 14 illustrate what happens. Referring to Chart No. 2 (Fig. 13), outdoor air at -18°C dry bulb and 75 percent rh (Point A) contains about 0.55 grams of moisture per kilogram of dry air. The 0.55 grams of moisture per kilogram of dry air is carried over to Chart No. 1 (Fig. 14) and a horizontal line (constant moisture line) is drawn.

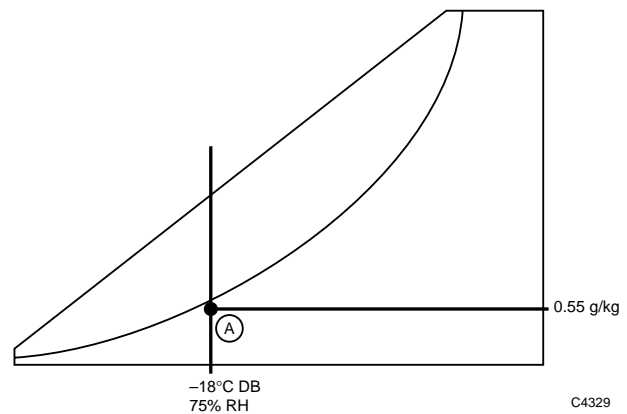

C4329

Fig. 13. Chart No. 2.

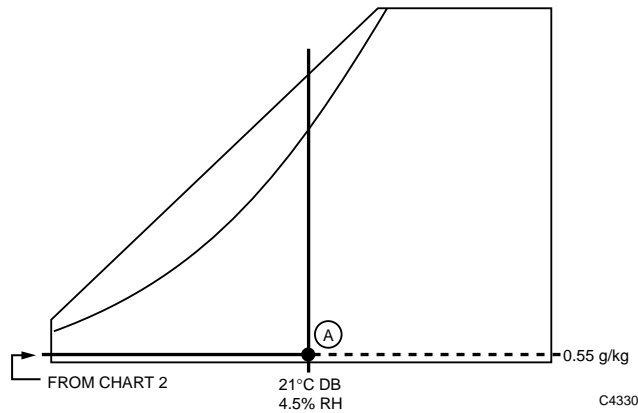

Fig. 14. Chart No. 1.

The outdoor air (−18°C at 75 percent rh) must be heated to a comfortable indoor air level. If the air is heated to 21°C, for example, draw a vertical line at that dry-bulb temperature. The intersection of the dry-bulb line and the moisture line determines the new condition. The moisture content is still 0.55 grams of moisture per kilogram of dry air, but the relative humidity drops to about 4.5 percent (Point A, Fig. 14). This indicates a need to add moisture to the air. Two examples of the humidifying process follow.

EXAMPLE 1:

Determine the amount of moisture required to raise the relative humidity from 4.5 percent to 35 percent when the air temperature is raised from −18°C to 21°C and then maintained at a constant 21°C.

Figure 15 provides an example of raising the relative humidity by adding moisture to the air. Assume this example represents a room that is 9 by 12 meters with an 2.5 meter ceiling and two air changes per hour. Determine how much moisture must be added to raise the relative humidity to 35 percent (Point B).

To raise the relative humidity from 4.5 percent (Point A) to 35 percent (Point B) at 21°C, the moisture to be added can be determined as follows:

1. The moisture content required for 21°C air at 35 percent rh is 5.5 grams of moisture per kilogram of dry air.
2. The moisture content of the heated air at 21°C and 4.5 percent rh is 0.55 grams of moisture per kilogram of dry air.
3. The moisture required is:

$$5.5 \text{ g/kg} - 0.55 \text{ g/kg} = 4.95 \text{ grams of moisture per kilogram of dry air}$$

Line A-B, Figure 15, represents this humidifying process on the psychrometric chart.

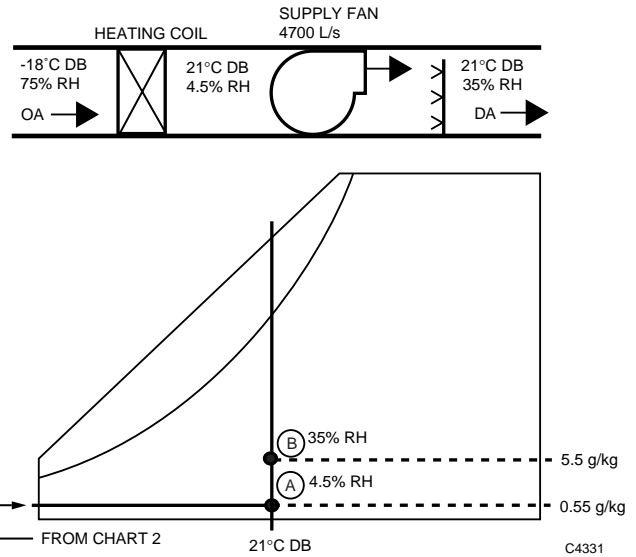

Fig. 15.

The space contains the following volume:

$$9\text{m} \times 12\text{m} \times 2.5\text{m} = 270 \text{ cubic meters}$$

Two air changes per hour is as follows:

$$2 \times 270\text{m}^3 = 540 \text{ cubic meters per hour}$$

or

$$540 \div (60 \times 60) = 150 \text{ liters per second}$$

This amount of air is brought into the room, heated to 21°C, and humidified. Chart No. 2 (Fig. 13) illustrates that outdoor air at −18°C has a volume of 0.712 cubic meters per kilogram. The reciprocal of this provides the density or 1.404 kilograms per cubic meter. Converting the cubic meters per hour of air to kilograms per hour provides:

$$540 \text{ m}^3/\text{hr} \times 1.404 \text{ kg/m}^3 = 758.2 \text{ kilograms of air per hour}$$

For the space in the example, the moisture that must be added is:

$$758.2 \text{ kg/hr} \times 4.95 \text{ g/kg} = 3753 \text{ grams} = 3.75 \text{ kilograms of water per hour}$$

EXAMPLE 2:

Determine the moisture required to provide 24°C air at 50 percent rh using 10°C air at 52 percent rh.

In this example, assume that 4700 liters of air per second must be humidified. First, plot the supply air Point A, Figure 16, at 10°C and 52 percent rh. Then, establish the condition after the air is heated to 24°C dry bulb. Since the moisture content has not changed, this is found at the intersection of the horizontal, constant moisture line (from Point A) and the vertical 24°C dry-bulb temperature line (Point B).

The air at Points A and B has 4.0 grams of moisture per kilogram of air. While the moisture content remains the same after the air is heated to 24°C (Point B), the relative humidity drops from 52 percent to 21 percent. To raise the relative humidity to 50 percent at 24°C, find the new point on the chart (the intersection of the 24°C dry-bulb line and the 50 percent rh curve or Point C). The moisture content at this point is 9.3 grams of moisture per kilogram of dry air. Calculate the moisture to be added as follows:

$$9.3 \text{ g/kg} - 4.0 \text{ g/kg} = 5.3 \text{ grams of moisture per kilogram of dry air}$$

Line B-C in Figure 16 represents this humidifying process on the psychrometric chart.

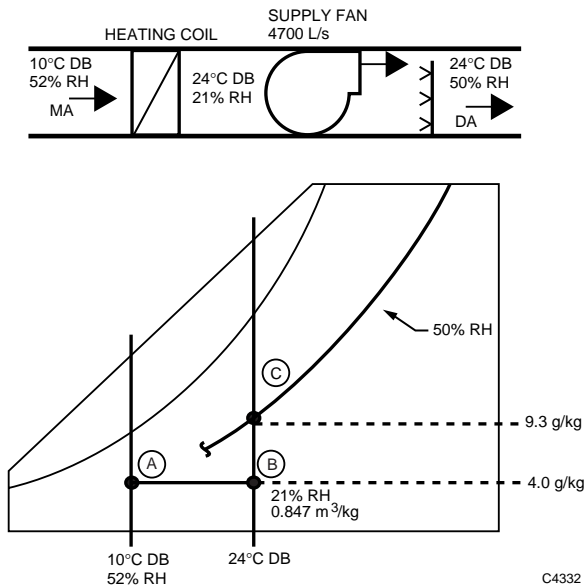

Fig. 16.

At 24°C and 21 percent relative humidity, the psychrometric chart shows that the volume of one kilogram of air is about 0.847 cubic meters. There are two ways to find the weight of the air. One way is to use the volume to find the weight. Assuming 4700 liters (4.7 m³) per second of air:

$$4.7 \text{ m}^3/\text{s} \div 0.847 \text{ m}^3/\text{kg} = 5.55 \text{ kilograms of air per second}$$

The other way is to use the density to find the weight. The reciprocal of the volume provides the density as follows:

$$1 \div 0.847 \text{ m}^3/\text{kg} = 1.18 \text{ kilograms per cubic meter}$$

The weight is then:

$$4.7 \text{ m}^3/\text{s} \times 1.18 \text{ kg/m}^3 = 5.55 \text{ kilograms of air per second}$$

If each kilogram of dry air requires 5.3 grams of moisture, then the following moisture must be added:

$$5.55 \text{ kg/s} \times 5.3 \text{ g/kg} = 29.4 \text{ grams of moisture per second}$$

Thus, a humidifier must provide 105.8 kilograms of water per hour to raise the space humidity to 50 percent at 24°C.

STEAM JET HUMIDIFIER

The most popular humidifier is the steam-jet type. It consists of a pipe with nozzles partially surrounded by a steam jacket. The jacket is filled with steam; then the steam is fed through nozzles and sprayed into the air stream. The jacket minimizes condensation when the steam enters the pipe with the nozzles and ensures dry steam for humidification. The steam is sprayed into the air at a temperature of 100°C or higher. The enthalpy includes the heat needed to raise the water temperature from 0 to 100°C, or 419 kJ plus 2256 kJ to change the water into steam. This is a total of 2675 kJ per kilogram of water at 0 kPa (gage) as it enters the air stream. (See Properties of Saturated Steam table in General Engineering Data section). The additional heat added to the air can be plotted on Chart No. 1 (Figure 17) to show the complete process. In this example, air enters the heating coil at 13 °C dry-bulb temperature (Point A) and is heated to 32 °C dry-bulb temperature (Point B) along a constant moisture line. It then enters the humidifier where the steam adds moisture and heats the air to Point C.

Figure 17 also shows use of the protractor nomograph. Assume the relative humidity of the air entering the humidifier at Point B is to be raised to 50 percent. A process line can be constructed using the protractor nomograph. The total heat of the entering steam in Kilojoule per kilogram is located on the enthalpy/humidity ratio scale ($\Delta h / \Delta W$) of the nomograph. This value, 2675 kilojoules per kilogram, is connected to the reference point of the nomograph to establish the slope of the process line on the psychrometric chart. A parallel line is drawn on the chart from Point B up to the 50 percent relative humidity line (Point C). The Line B-C is the process line. The Line X-Y (bottom of the chart) is simply a perpendicular construction line for drawing the Line B-C parallel to the line determined on the nomograph. Note that the dry-bulb temperature increased from 32 to 33°C.

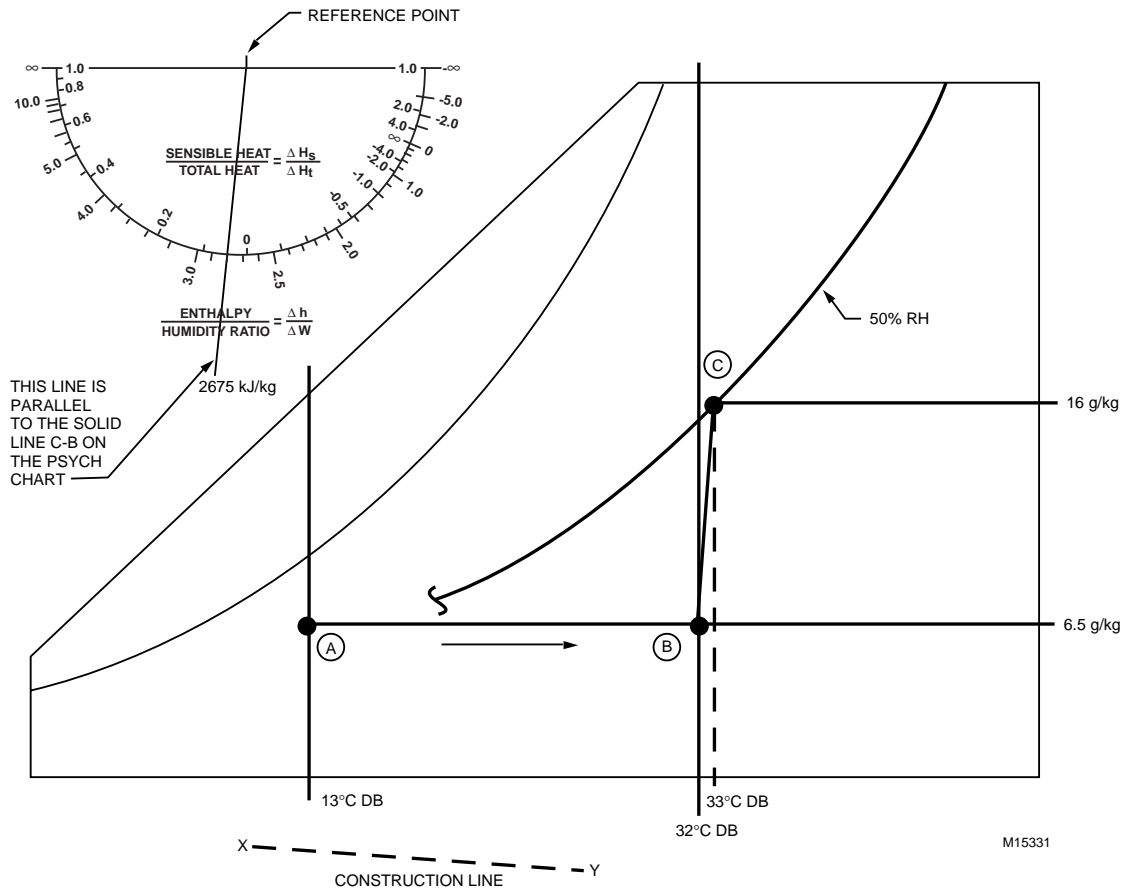

Fig. 17.

PSYCHROMETRIC CHART FUNDAMENTALS

Figure 18 is the same as the chart shown in Figure 17 except that it graphically displays the amount of heat added by the process. Enthalpy (total heat) added is determined by subtracting the enthalpy of the dry, heated air at Point B from the enthalpy of the humidified air at Point C as follows:

$$74.5 \text{ kJ/kg} - 49.0 \text{ kJ/kg} = 25.5 \text{ kilojoules per kilogram of dry air}$$

The steam raised the temperature of the air from 32°C dry bulb to 33°C dry bulb. To find the latent heat added by the steam humidifier to the air, determine the enthalpy at Point D (the enthalpy of the heated air without added moisture) and subtract it from the enthalpy of the humidified air at Point C. This is as follows:

$$74.5 \text{ kJ/kg} - 49.8 \text{ kJ/kg} = 24.7 \text{ kilojoules per kilogram of dry air}$$

The remaining 0.8 kJ/kg is sensible heat. The actual moisture added per kilogram of dry air is 9.5 grams. The specific volume of the entering air at Point B is 0.874 cubic meters per kilogram.

For a 4.72 cubic meters per Second system, the weight of the air passing through is:

$$4.72 \text{ m}^3/\text{s} \div 0.874 \text{ m}^3/\text{kg} = 5.4 \text{ kilograms per second}$$

The weight of the moisture added is:

$$5.4 \text{ kg/s} \times 9.5 \text{ g/kg} = 51.3 \text{ grams per second of moisture}$$

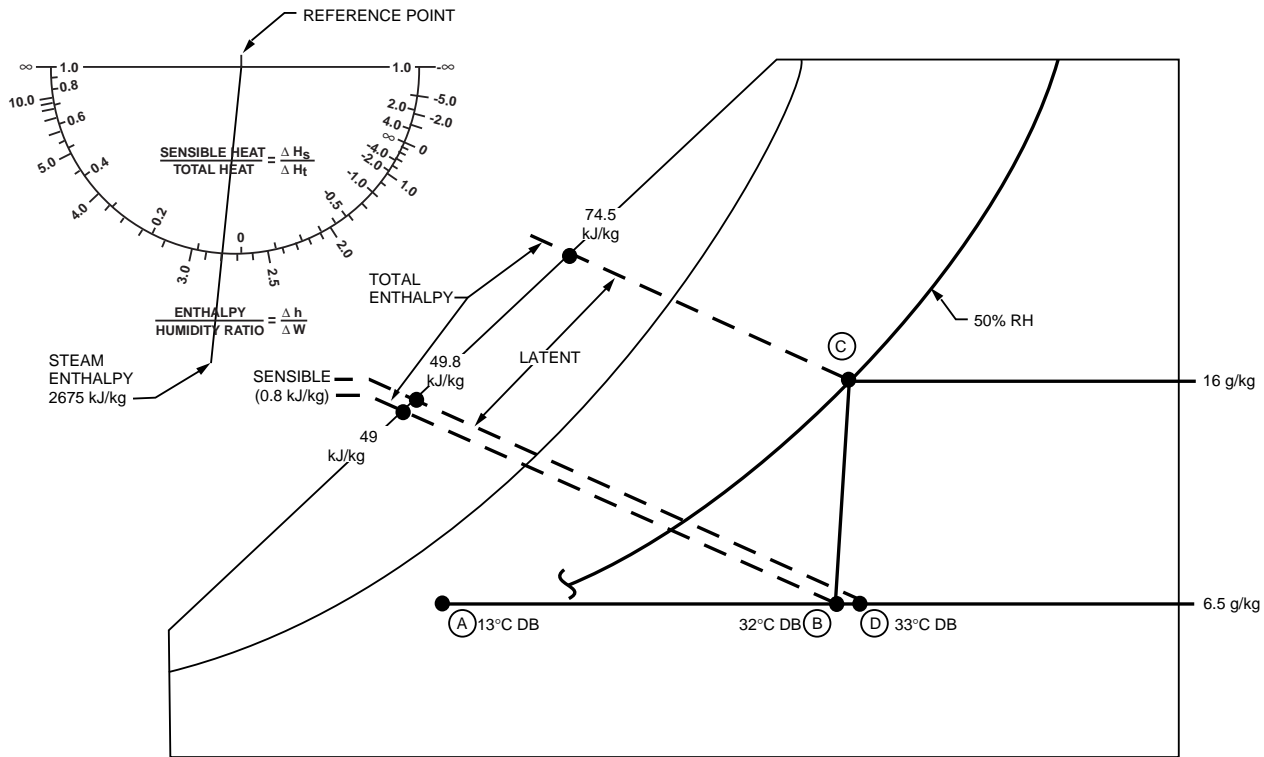

M15330

Fig. 18.

Recalling that the steam added 25.5 kilojoules per kilogram of dry air, the total heat added is:

$$5.4 \text{ kg/s} \times 25.5 \text{ kJ/kg} = 137.7 \text{ kilojoules per second}$$

Summarized, a steam humidifier always adds a little sensible heat to the air, and the Process Line B–C angles to the right of the 32°C starting dry-bulb line because of the added sensible heat. When the process line crosses the moisture content lines along a constant dry-bulb line, only latent heat is added. When it parallels a constant, horizontal moisture line, only sensible heat is added.

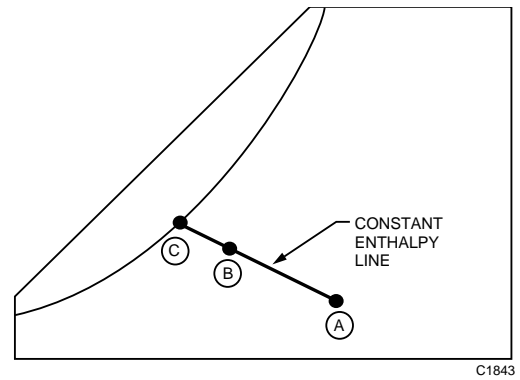

Fig. 21.

AIR WASHERS

Air washers are also used as humidifiers particularly for applications requiring added moisture and not much heat as in warm southwestern climates. A washer can be recirculating as shown in Figure 19 or heated as shown in Figure 20. In recirculating washers, the heat necessary to vaporize the water is sensible heat changed to latent heat which causes the dry-bulb temperature to drop. The process line tracks the constant enthalpy line because no total heat is added or subtracted. This process is called “adiabatic” and is illustrated by Figure 21. Point A is the entering condition of the air, Point B is the final condition, and Point C is the temperature of the water. Since the water is recirculating, the water temperature becomes the same as the wet-bulb temperature of the air.

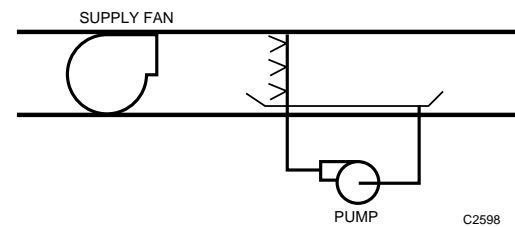

Fig. 19. Recirculating Air Washer.

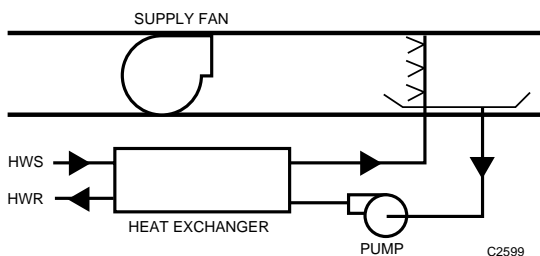

Fig. 20. Heated Air Washer.

The next two psychrometric charts (Fig. 22 and 23) illustrate the humidifying process using a heated air washer. The temperature to which the water is heated is determined by the amount of moisture required for the process. Figure 22 shows what happens when the washer water is heated above the air dry-bulb temperature shown at Point A. The temperature of the water located at Point B on the saturation curve causes the system air temperature to settle out at Point D. The actual location of Point D depends upon the construction and characteristics of the washer.

As the humidity demand reduces, the water temperature moves down the saturation curve as it surrenders heat to the air. This causes the water temperature to settle out at a point such as Point C. The final air temperature is at Point E. Note that the final air temperature is above the initial dry-bulb temperature so both sensible and latent heat have been added to the air.

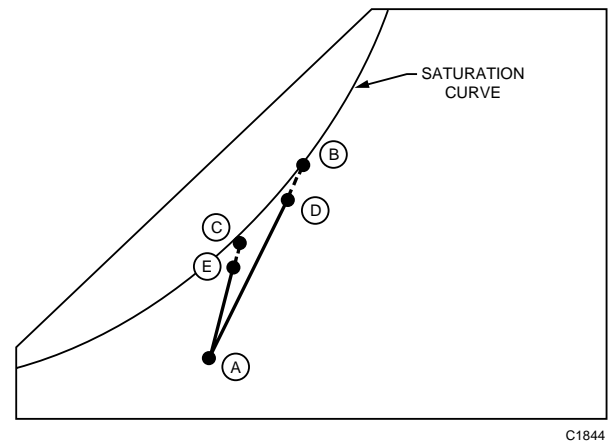

Fig. 22.

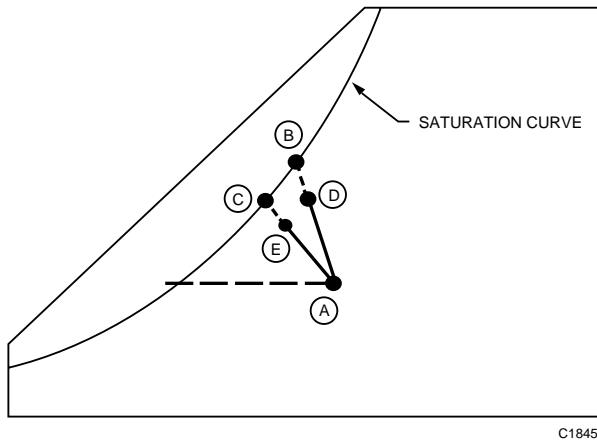

Fig. 23.

Figure 23 illustrates a heated washer where the water temperature is between the dry-bulb and wet-bulb temperatures of the air. The air is humidified but also cooled a little. Point B represents the initial and Point C the final temperature of the water with reduced humidity demand. Point A represents the initial and Point E the final temperature of the air. The location of Points D and E depends on the construction and characteristics of the washer. The temperature of the water in a

washer is always located on the saturation curve. Note that the dry-bulb temperature of the air is reduced as it passes through the washer. This happens because some of its heat is used to evaporate the water; however, the humidity of the air rises considerably. In this case, some of the sensible heat of the air becomes latent heat in the water vapor, but the enthalpy of the air is increased because of the heat in the water.

VAPORIZING HUMIDIFIER

Vaporizing and water spray humidifiers operate on the principal of breaking water up into small particulates so they are evaporated directly into the air. This process is essentially adiabatic since the enthalpy lines of the water vapor for 0 and 100°C are so close. The enthalpy of water at 0°C is zero and at 100°C it is 419 kilojoules per kilogram. If air at Point A (Fig. 24) is humidified by 100°C water, the process follows a line parallel to line C-D and the 26°C WB line and ends at a point such as Point B. The actual water temperature of a vaporizing or water spray humidifier will be between 0°C and 100°C and will usually be around room temperature so using the zero enthalpy line (C-E) as reference will not introduce a significant error into the process.

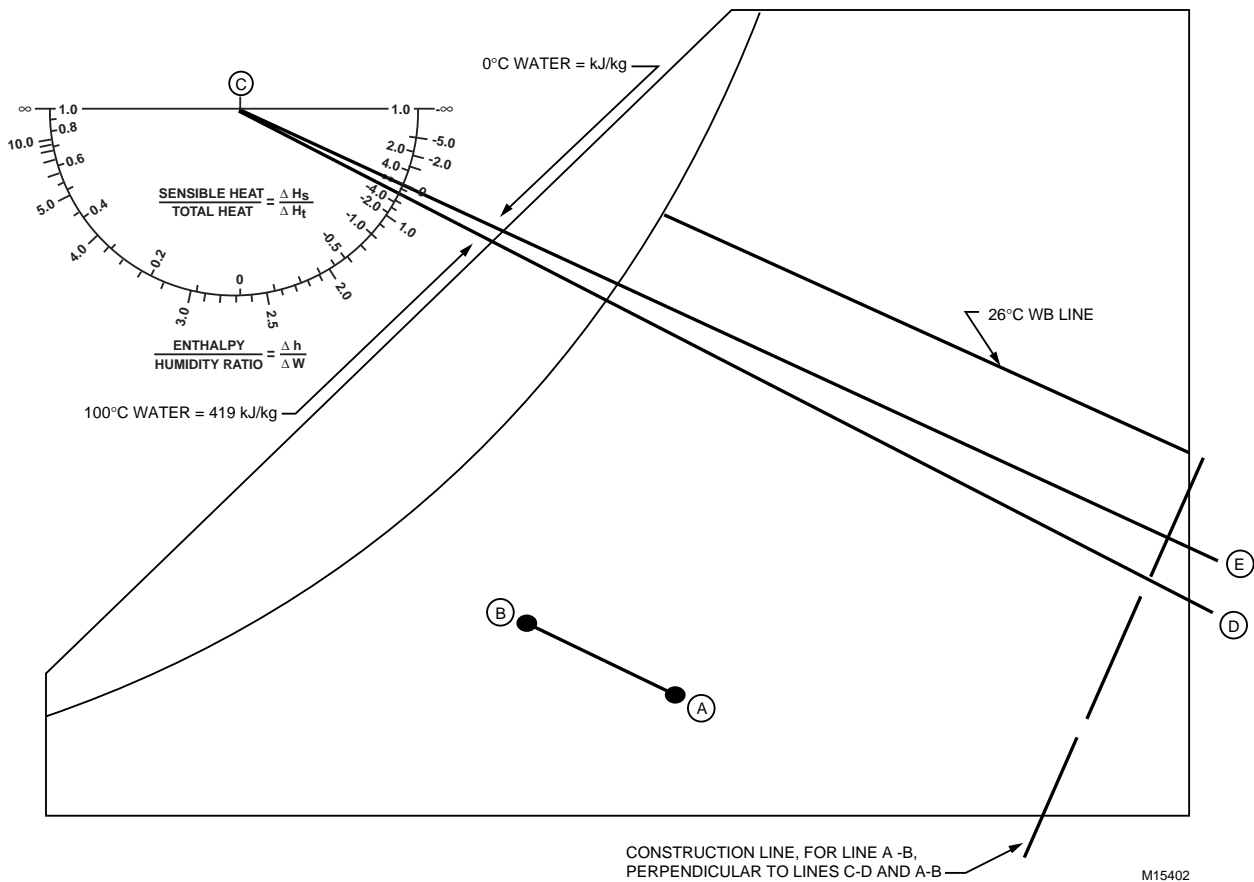

Fig. 24. Psychrometric Chart Showing Line A-B Parallel to Line C-D.

COOLING AND DEHUMIDIFICATION

BASIC PROCESS

Cooling and dehumidification can be accomplished in a single process. The process line moves in a decreasing direction across both the dry-bulb temperature lines and the constant moisture lines. This involves both sensible and latent cooling.

Figure 12 illustrates cooling air by removing sensible heat only. In that illustration, the resulting cooled air was 95 percent relative humidity, a condition which often calls for reheat (see DEHUMIDIFICATION AND REHEAT). Figure 25 illustrates a combination of sensible and latent cooling. Whenever the surface temperature of the cooling device (Point B), such as a chilled water coil, is colder than the dew point temperature of the entering air (Point A), moisture is removed from the air contacting the cold surface. If the coil is 100 percent efficient, all entering air contacts the coil and leaving air is the same temperature as the surface of the coil.

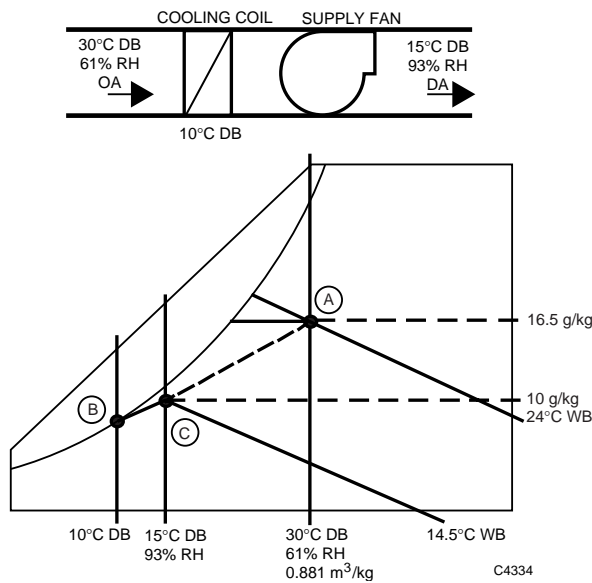

Fig. 25.

All coils, however, are not 100 percent efficient and all air does not come in contact with the coil surface or fins. As a result, the temperature of the air leaving the coil (Point C) is somewhere between the coolest fin temperature (Point B) and the entering outdoor air temperature (Point A). To determine this exact point requires measuring the dry-bulb and wet-bulb temperatures of the leaving air.

To remove moisture, some air must be cooled below its dew point. By determining the wet-bulb and the dry-bulb temperatures of the leaving air, the total moisture removed per kilogram of dry air can be read on the humidity ratio scale and is determined as follows:

1. The entering air condition is 30°C dry bulb and 61 percent rh (Point A). The moisture content is 16.5 grams of moisture per kilogram of dry air.
2. The leaving air condition is 15°C dry bulb and 93 percent rh (Point C). The moisture content is 10 grams of moisture per kilogram of dry air.
3. The moisture removed is:

$$16.5 \text{ g/kg} - 10 \text{ g/kg} = 6.5 \text{ grams of moisture per kilogram of dry air}$$

The volume of air per kilogram at 30°C dry bulb and 24°C wet bulb (Point A) is 0.881 cubic meters per kilogram of dry air. If 2.5 cubic meters of air per second passes through the coil, the weight of the air is as follows:

$$2.5 \text{ m}^3/\text{s} \div 0.881 \text{ m}^3/\text{kg} = 2.84 \text{ kilograms per second}$$

The kilograms of water removed is as follows:

$$2.84 \text{ kg/s} \times 6.5 \text{ g/kg} = 18.46 \text{ grams per second}$$

or

$$\frac{18.46 \text{ g/s} \times 60 \times 60}{1000 \text{ g/kg}} = 66.4 \text{ kilograms per hour}$$

AIR WASHERS

Air washers are devices that spray water into the air within a duct. They are used for cooling and dehumidification or for humidification only as discussed in the HUMIDIFYING PROCESS—AIR WASHERS section. Figure 26 illustrates an air washer system used for cooling and dehumidification. The chiller maintains the washer water to be sprayed at a constant 10°C. This allows the chilled water from the washer to condense water vapor from the warmer entering air as it falls into the pan. As a result, more water returns from the washer than has been delivered because the temperature of the chilled water is lower than the dew point (saturation temperature) of the air. The efficiency of the washer is determined by the number and effectiveness of the spray nozzles used and the speed at which the air flows through the system. The longer the air is in contact with the water spray, the more moisture the spray condenses from the air.

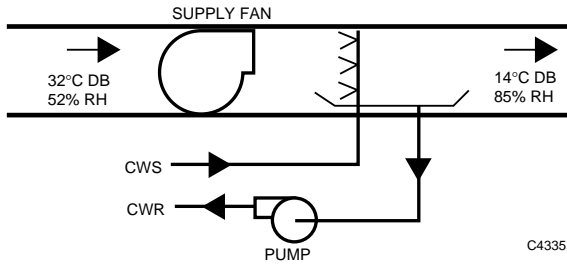

Fig. 26. Air Washer Used for Cooling and Dehumidification.

Figure 27 is a chart of the air washer process. If a washer is 100 percent efficient, the air leaving the washer is at Point B. The result as determined by the wet-bulb and dry-bulb temperatures is Point C and is determined as follows:

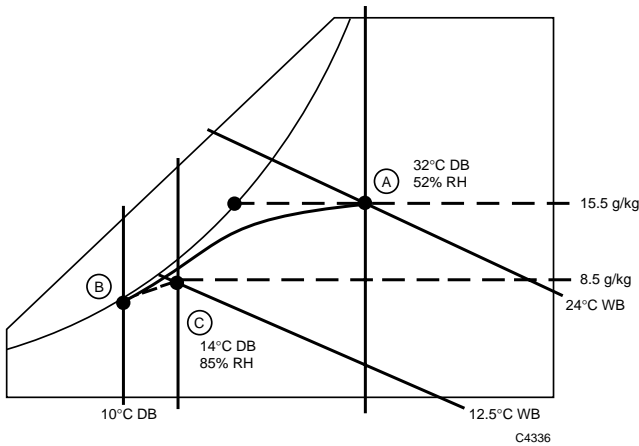

Fig. 27.

1. The entering condition air is 32°C dry bulb and 52 percent rh (Point A). The moisture content is 15.5 grams of moisture per kilogram of dry air.
2. Air that contacts the spray droplets follows the saturation curve to the spray temperature, 10°C dry bulb (Point B), and then mixes with air that did not come in contact with the spray droplets resulting in the average condition at Point C.
3. The leaving air is at 14°C dry bulb and 85 percent rh (Point C). The moisture content is 8.5 grams of moisture per kilogram of dry air.
4. The moisture removed is:

$$15.5 \text{ g/kg} - 8.5 \text{ g/kg} = 7 \text{ grams of moisture per kilogram of dry air}$$

Figure 28 summarizes the process lines for applications using washers for humidification or dehumidification. When the water recirculates, the process is adiabatic and the process line follows the Constant Enthalpy Line A-C. The water assumes the wet-bulb temperature of the air as the process line extends. Note that whenever the washer water temperature is between the dew point (Point B) and the dry-bulb (Point D) temperature of the air, moisture is added and the dry-bulb temperature of the air falls. If the water temperature is above the dry-bulb temperature of the air (to the right of Point D), both the air moisture and the dry-bulb temperature increase. Whenever the water temperature is below the dew point temperature (Point B), dehumidification occurs as well as dry-bulb cooling. This process always falls on a curved line between the initial temperature of the air and the point on the saturation curve representing the water temperature. The exact leaving air temperature depends upon the construction and characteristics of the washer.

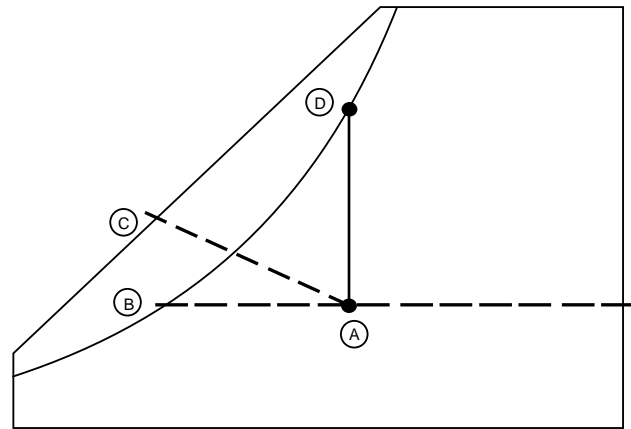

Fig. 28.

DEHUMIDIFICATION AND REHEAT

Dehumidification lowers the dry-bulb temperature, which often requires the use of reheat to provide comfortable conditions. Dehumidification and reheat are actually two processes on the psychrometric chart. Applications, such as computer rooms, textile mills, and furniture manufacturing plants require that a constant relative humidity be maintained at close tolerances. To accomplish this, the air is cooled below a comfortable level to remove moisture, and is then reheated (sensible heat only) to provide comfort. Figure 29 is an air conditioning system with both a cooling coil and reheat coil.

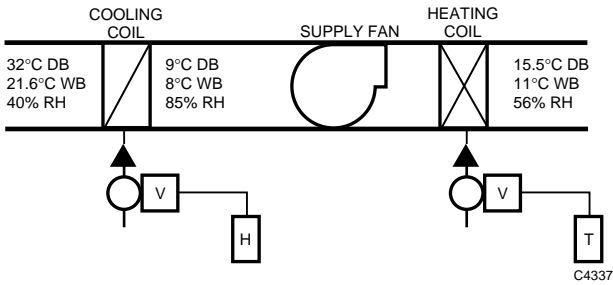

Fig. 29. Fan System with Dehumidification and Reheat.

Figure 30 illustrates cooling and dehumidification with reheat for maintaining constant relative humidity. Air enters the coils at Point A, is cooled and dehumidified to Point B, is reheated to Point C, and is then delivered to the controlled space. A space humidistat controls the cooling coil valve to maintain the space relative humidity. A space thermostat controls the reheat coil to maintain the proper dry-bulb temperature.

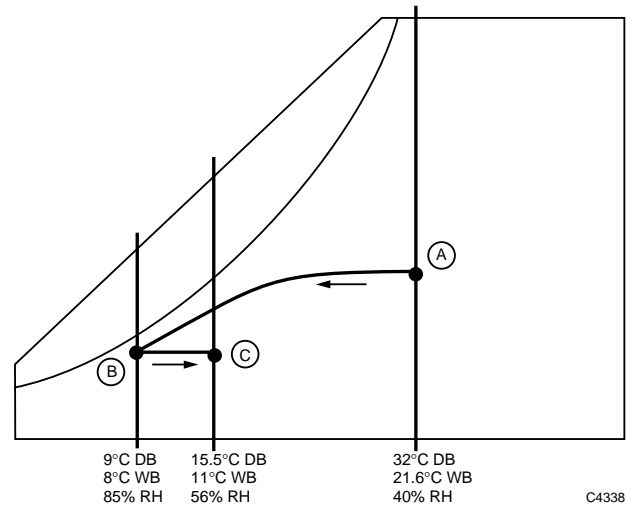

Fig. 30.

PROCESS SUMMARY

Figures 31 and 32 summarize some principles of the air conditioning process as illustrated by psychrometric charts.

- Sensible heating or cooling is always along a constant moisture line.
- When latent heat is added or removed, a process line always crosses the constant moisture lines.
- Enthalpy and humidity ratio, or moisture content, are based on a kilogram of dry air. Zero moisture is the bottom line of the chart.

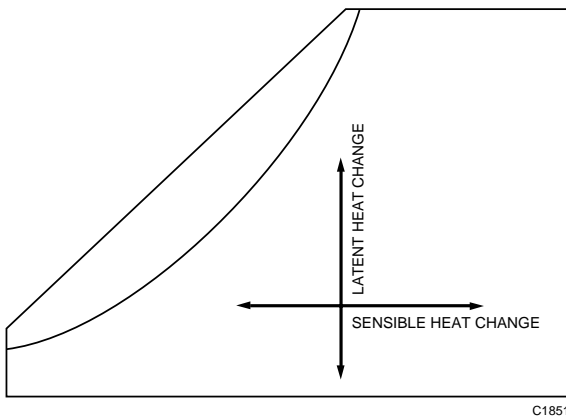
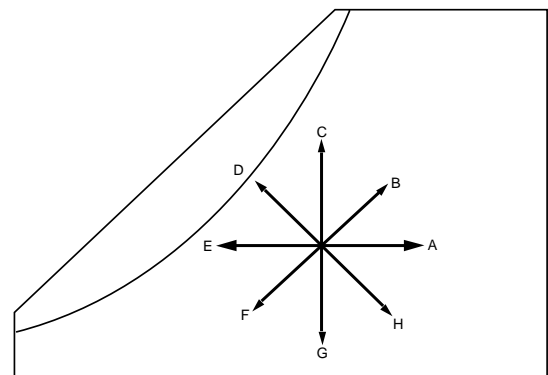

Fig. 31.

- To find the sensible heat content of any air in kilojoules, follow the dry-bulb line to the bottom of the chart and read the enthalpy there, or project along the enthalpy line, and read the kilojoules per kilogram of dry air on the enthalpy scale.



- SUMMARY OF ALL PROCESSES CHARTABLE.
 PROCESS MOVEMENT IN THE DIRECTION OF:
- A, HEATING ONLY - STEAM, HOT WATER OR ELECTRIC HEAT COIL
 - B, HEATING AND HUMIDIFYING - STEAM HUMIDIFIER OR RECIRCULATED HOT WATER SPRAY
 - C, HUMIDIFYING ONLY - AIR WASHER WITH HEATED WATER
 - D, COOLING AND HUMIDIFYING - WASHER
 - E, COOLING ONLY - COOLING COIL OR WASHER AT DEWPOINT TEMPERATURE
 - F, COOLING AND DEHUMIDIFYING - CHILLED WATER WASHER
 - G, DEHUMIDIFYING ONLY - NOT PRACTICAL
 - H, DEHUMIDIFYING AND HEATING - CHEMICAL DEHUMIDIFIER

Fig. 32.

ASHRAE PSYCHROMETRIC CHARTS

The following two pages illustrate ASHRAE Psychrometric Charts No. 1 and No. 2.

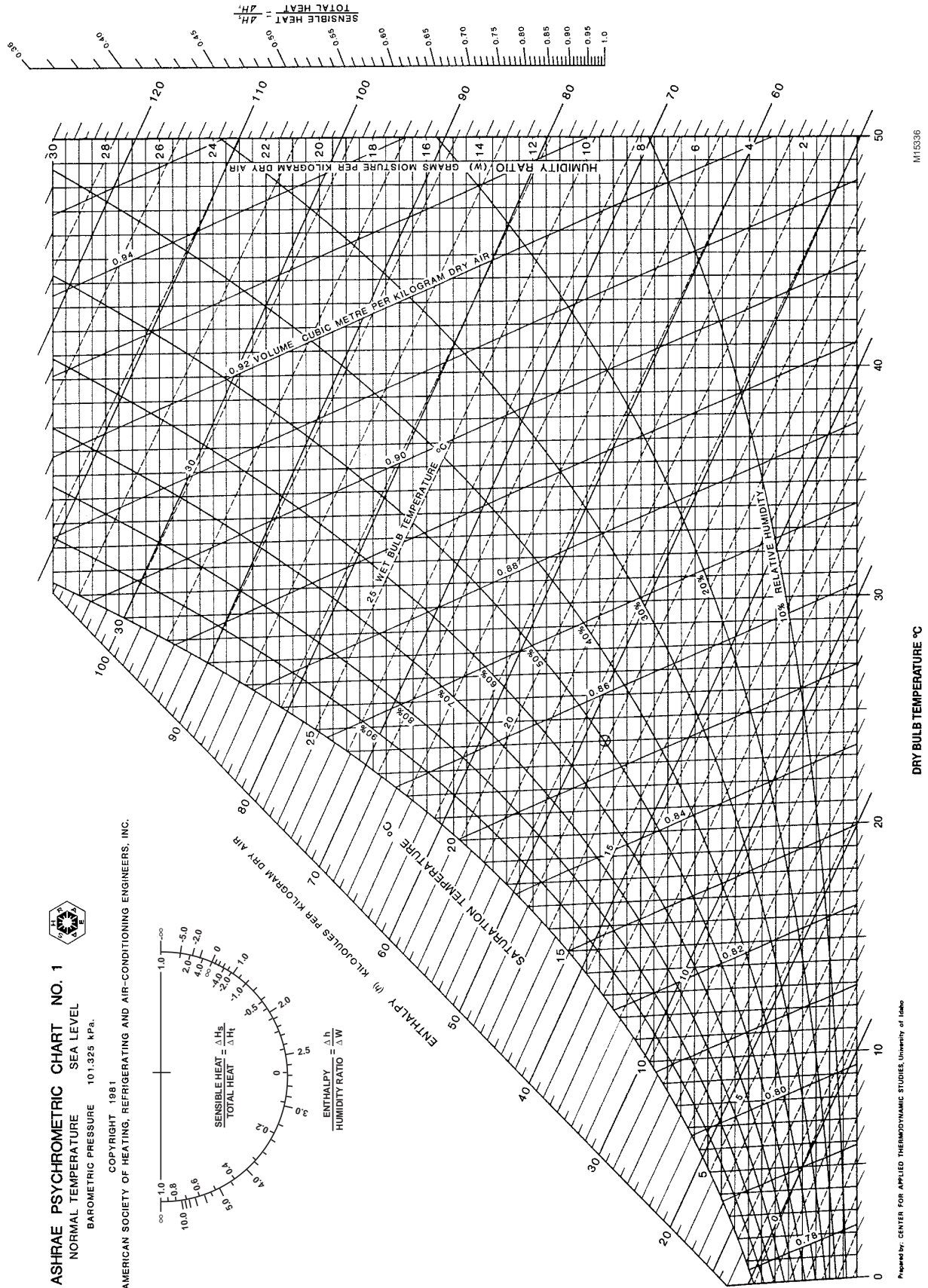

Fig. 33. ASHRAE Psychrometric Chart No. 1.

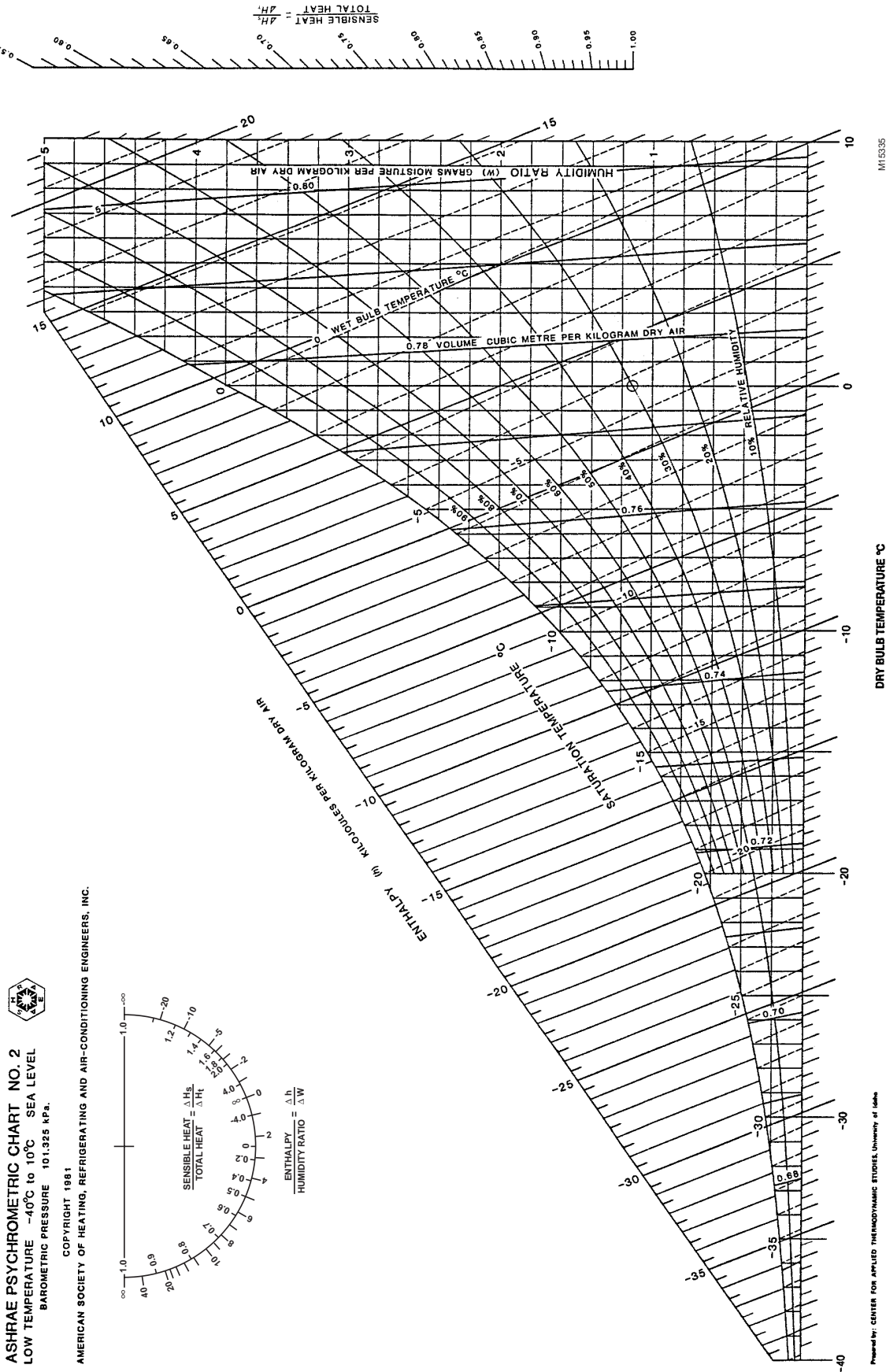

Fig. 34. ASHRAE Psychrometric Chart No. 2.

Pneumatic Control Fundamentals

ENGINEERING MANUAL OF AUTOMATIC CONTROL

		CONTENTS
Introduction	59
Definitions	59
Abbreviations	60
Symbols	61
Basic Pneumatic Control System	61
General	61
Air Supply and Operation	61
Restrictor	62
Nozzle-Flapper Assembly	62
Pilot Bleed System	62
Signal Amplifier	63
Feed and Bleed System	63
Sensing Elements	63
Bimetal	63
Rod and Tube	64
Remote Bulb	64
Averaging Element	64
Throttling Range Adjustment	64
Relays and Switches	64
Air Supply Equipment	65
General	65
Air Compressor	65
Air Drying Techniques	66
General	66
Dry Air Requirement	66
Condensing Drying	67
High-Pressure Drying	67
Refrigerant Drying	67
Desiccant Drying	67
Pressure Reducing Valve Station	68
Air Filter	68
Pressure Reducing Valves	69
Single-Pressure Reducing Valve	69
Two-Pressure Reducing Valve	69
Thermostats	69
Controllers	70
General	70
Temperature Controllers	71
Humidity Controllers	71
Pressure Controllers	71

Sensor-Controller Systems	72
Pneumatic Controllers	72
Proportional-Integral (PI) Controllers	72
Controller Adjustments	72
Pneumatic Sensors	73
Velocity Sensor-Controller	73
Actuators and Final Control Elements	74
Actuators	74
General	74
Spring Ranges	74
Control Valves	75
Dampers	76
Relays and Switches	77
Switching Relay	77
Snap Acting Relay	78
Lockout Relay	78
High-Pressure Selector Relay	79
Low-Pressure Selector Relay	79
Load Analyzer Relay	79
Capacity Relay	79
Reversing Relay	80
Positive-Positioning Relay	80
Averaging Relay	80
Ratio Relay	81
Pneumatic Potentiometer	81
Hesitation Relay	82
Electrical Interlocking Relays	82
Electric-Pneumatic Relay	82
Pneumatic-Electric Relay	82
Electronic-Pneumatic Transducer	83
Pneumatic Switch	83
Manual Positioning Switch	84
Pneumatic Control Combinations	84
General	84
Sequence Control	85
Limit Control	85
Manual Switch Control	86
Changeover Control for Two-Pressure Supply System	87
Compensated Control System	87
Electric-Pneumatic Relay Control	87
Pneumatic-Electric Relay Control	88
Pneumatic Recycling Control	88
Pneumatic Centralization	89
Pneumatic Control System Example	90
Start-Stop Control Sequence	90
Supply Fan Control Sequence	92
Return Fan Control Sequence	92
Warm-up/Heating Coil Control Sequence	92
Mixing Damper Control Sequence	93
Discharge Air Temperature Control Sequence	94
Off/Failure Mode Control Sequence	94

INTRODUCTION

This section provides basic information on pneumatic control systems and components commonly used to control equipment in commercial heating and air conditioning applications. The information in this section is of a general nature in order to explain the fundamentals of pneumatic control. Some terms and references may vary between manufacturers (e.g., switch port numbers).

Pneumatic control systems use compressed air to operate actuators, sensors, relays, and other control equipment. Pneumatic controls differ from other control systems in several ways with some distinct advantages:

- Pneumatic equipment is inherently proportional but can provide two-position control when required.

- Many control sequences and combinations are possible with relatively simple equipment.
- Pneumatic equipment is suitable where explosion hazards exist.
- The installed cost of pneumatic controls and materials may be lower, especially where codes require that low-voltage electrical wiring for similar electric controls be run in conduit.
- Quality, properly installed pneumatic equipment is reliable. However, if a pneumatic control system requires troubleshooting or service, most building-maintenance people have the necessary mechanical knowledge.

DEFINITIONS

Actuator: A mechanical device that operates a final control element (e.g., valve, damper).

Authority (Reset Authority or Compensation Authority): A setting that indicates the relative effect a compensation sensor input has on the main setpoint (expressed in percent).

Branch line: The air line from a controller to the controlled device.

Branchline pressure (BLP): A varying air pressure signal from a controller to an actuator carried by the branch line. Can go from atmospheric to full main line pressure.

Compensation changeover: The point at which the compensation effect is reversed in action and changes from summer to winter or vice versa. The percent of compensation effect (authority) may also be changed at the same time.

Compensation control: A process of automatically adjusting the control point of a given controller to compensate for changes in a second measured variable such as outdoor air temperature. For example, the hot deck control point is reset upward as the outdoor air temperature decreases. Also known as “reset control”.

Compensation sensor: The system element which senses a variable other than the controlled variable and resets the main sensor control point. The amount of this effect is established by the authority setting.

Control point: The actual value of the controlled variable (setpoint plus or minus offset).

Controlled variable: The quantity or condition that is measured and controlled (e.g., temperature, relative humidity, pressure).

Controller: A device that senses the controlled variable or receives an input signal from a remote sensing element, compares the signal with the setpoint, and outputs a control signal (branchline pressure) to an actuator.

Differential: A term that applies to two-position devices. The range through which the controlled variable must pass in order to move the final control element from one to the other of its two possible positions. The difference between cut-in and cut-out temperatures, pressures, etc.

Direct acting (DA): A direct-acting thermostat or controller increases the branchline pressure on an increase in the measured variable and decreases the branchline pressure on a decrease in the variable. A direct-acting actuator extends the shaft on an increase in branchline pressure and retracts the shaft on a decrease in pressure.

Discharge air: Conditioned air that has passed through a coil. Also, air discharged from a supply duct outlet into a space. See Supply air.

Final control element: A device such as a valve or damper that acts to change the value of the manipulated variable. Positioned by an actuator.

Main line: The air line from the air supply system to controllers and other devices. Usually plastic or copper tubing.

Manipulated variable: Media or energy controlled to achieve a desired controlled variable condition.

Measuring element: Same as sensing element.

Mixed air: Typically a mixture of outdoor air and return air from the space.

Modulating: Varying or adjusting by small increments. Also called “proportioning”.

Offset: A sustained deviation between the actual system control point and its controller setpoint under stable operating conditions. Usually applies to proportional (modulating) control.

Proportional band: As applied to pneumatic control systems, the change in the controlled variable required to change the controller output pressure from 20 to 90 kPa. Usually expressed as a percentage of sensor span.

Reset control: See compensation control.

Restrictor: A device in an air line that limits the flow of air.

Return air: Air entering an air handling system from the occupied space.

Reverse acting (RA): A reverse-acting thermostat or controller decreases the branchline pressure on an increase in the measured variable and increases the branchline pressure on a decrease in the variable. A reverse-acting valve actuator retracts the shaft on an increase in branchline pressure and extends the shaft on a decrease in pressure.

Sensing element: A device that detects and measures the controlled variable (e.g., temperature, humidity).

Sensor: A device placed in a medium to be measured or controlled that has a change in output signal related to a change in the sensed medium.

Sensor Span: The variation in the sensed media that causes the sensor output to vary between 20 to 100 kPa.

Setpoint: The value on the controller scale at which the controller is set (e.g., the desired room temperature set on a thermostat). The desired control point.

Supply air: Air leaving an air handling system.

Thermostat: A device that responds to changes in temperature and outputs a control signal (branchline pressure). Usually mounted on a wall in the controlled space.

Throttling range: Related to proportional band, and expressed in values of the controlled variable (e.g., degrees, percent relative humidity, kilopascals) rather than in percent.

ABBREVIATIONS

The following port abbreviations are used in drawings of relays and controllers:

B	—	Branch
C	—	Common
E	—	Exhaust
M	—	Main
O	—	Normally connected*
X	—	Normally disconnected*
P	—	Pilot (P_1 and P_2 for dual-pilot relays)
S	—	Sensor (S_1 and S_2 for dual-input controllers)

N.C.	—	Normally closed
N.O.	—	Normally open

* The normally connected and common ports are connected on a fall in pilot pressure below the relay setpoint, and the normally disconnected port is blocked. On a rise in pilot pressure above the relay setpoint, the normally disconnected and common ports are connected and the normally connected port is blocked. Refer to Figure 38 in RELAYS AND SWITCHES.

SYMBOLS

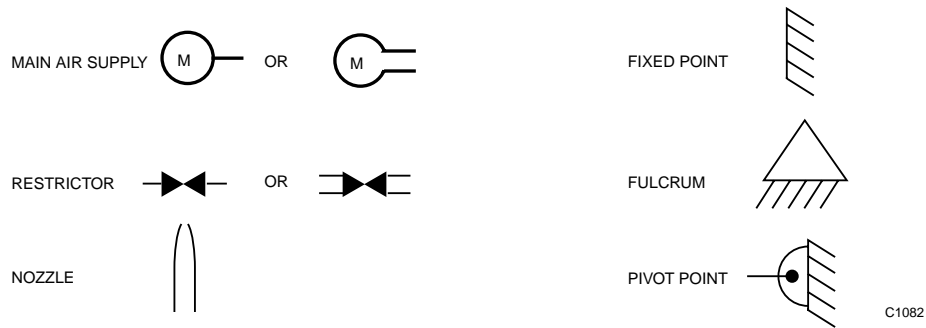

BASIC PNEUMATIC CONTROL SYSTEM

GENERAL

A pneumatic control system is made up of the following elements:

- Compressed air supply system
- Main line distribution system
- Branch lines
- Sensors
- Controllers
- Actuators
- Final control elements (e.g., valves, dampers)

A basic pneumatic control system consists of an air supply, a controller such as a thermostat, and an actuator positioning a valve or damper (Fig. 1).

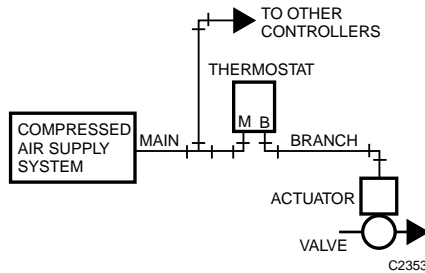

Fig. 1. Basic Pneumatic Control System.

The controller receives air from the main line and regulates its output pressure (branchline pressure) as a function of the temperature, pressure, humidity, or other variable. The branchline pressure from the controller can vary from atmospheric to full mainline pressure. The regulated branchline pressure energizes the actuator, which then assumes a position proportional to the branchline pressure applied. The actuator usually goes through its full stroke as the branchline pressure changes from 20 kPa to 90 kPa. Other pressure ranges are available.

In a typical control system, the final control element (a valve or a damper) is selected first because it must produce the desired control results. For example, a system designed to control the flow of water through a coil requires a control valve. The type of valve, however, depends on whether the water is intended for heating or cooling, the water pressure, and the control and flow characteristics required. An actuator is then selected to operate the final control element. A controller and relays complete the system. When all control systems for a building are designed, the air supply system can be sized and designed.

AIR SUPPLY AND OPERATION

The main line air supply is provided by an electrically driven compressor pumping air into a storage tank at high pressure (Fig. 2). A pressure switch turns the compressor on and off to maintain the storage tank pressure between fixed limits. The tank stores the air until it is needed by control equipment. The air dryer removes moisture from the air, and the filter removes oil and other impurities. The pressure reducing valve (PRV) typically reduces the pressure to 125 to 150 kPa. For two-pressure (day/night) systems and for systems designed to change from direct to reverse acting (heating/cooling), the PRV switches between two pressures, such as 90 and 125 kPa. The maximum safe air pressure for most pneumatic controls is 170 kPa.

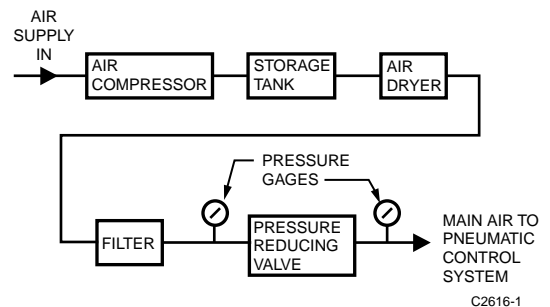

Fig. 2. Compressed Air Supply System.

From the PRV, the air flows through the main line to the controller (in Figure 1, a thermostat) and to other controllers or relays in other parts of the system. The controller positions the actuator. The controller receives air from the main line at a constant pressure and modulates that pressure to provide branchline air at a pressure that varies according to changes in the controlled variable, as measured by the sensing element. The controller signal (branchline pressure) is transmitted via the branch line to the controlled device (in Figure 1, a valve actuator). The actuator drives the final control element (valve) to a position proportional to the pressure supplied by the controller.

When the proportional controller changes the air pressure to the actuator, the actuator moves in a direction and distance proportional to the direction and magnitude of the change at the sensing element.

RESTRICTOR

The restrictor is a basic component of a pneumatic control system and is used in all controllers. A restrictor is usually a disc with a small hole inserted into an air line to restrict the amount of airflow. The size of the restrictor varies with the application, but can have a hole as small as 0.08 millimeters.

NOZZLE-FLAPPER ASSEMBLY

The nozzle-flapper assembly (Fig. 3) is the basic mechanism for controlling air pressure to the branch line. Air supplied to the nozzle escapes between the nozzle opening and the flapper. At a given air supply pressure, the amount of air escaping is determined by how tightly the flapper is held against the nozzle by a sensing element, such as a bimetal. Thus, controlling the tension on the spring also controls the amount of air escaping. Very little air can escape when the flapper is held tightly against the nozzle.

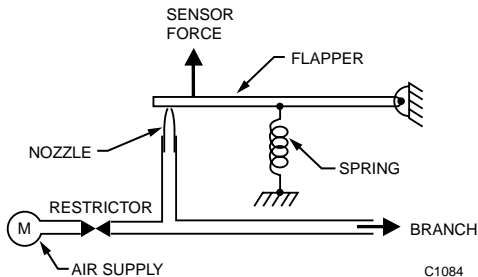

Fig. 3. Nozzle-Flapper Assembly with Restrictor.

To create a branchline pressure, a restrictor (Fig. 3) is required. The restrictor and nozzle are sized so that the nozzle can exhaust more air than can be supplied through the restrictor when the flapper is off the nozzle. In that situation, the branchline pressure is near zero. As the spring tension increases to hold the flapper tighter against the nozzle, reducing the air escaping, the branchline pressure increases proportionally. When the spring tension prevents all airflow from the nozzle, the branchline pressure becomes the same as the mainline pressure (assuming no air is flowing in the branch line). This type of control is called a “bleed” control because air “bleeds” continuously from the nozzle.

With this basic mechanism, all that is necessary to create a controller is to add a sensing element to move the flapper as the measured variable (e.g., temperature, humidity, pressure) changes. Sensing elements are discussed later.

PILOT BLEED SYSTEM

The pilot bleed system is a means of increasing air capacity as well as reducing system air consumption. The restrictor and nozzle are smaller in a pilot bleed system than in a nozzle-flapper system because in a pilot bleed system they supply air only to a capacity amplifier that produces the branchline pressure (Fig. 4). The capacity amplifier is a pilot bleed component that maintains the branchline pressure in proportion to the pilot pressure but provides greater airflow capacity.

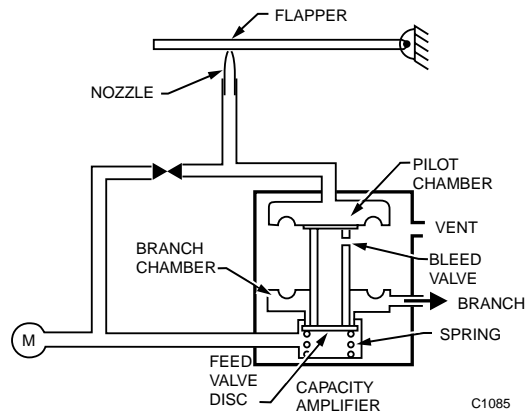

Fig. 4. Pilot Bleed System with Amplifier Relay.

The pilot pressure from the nozzle enters the pilot chamber of the capacity amplifier. In the state shown in Figure 4, no air enters or leaves the branch chamber. If the pilot pressure from the nozzle is greater than the spring force, the pilot chamber

diaphragm is forced down, which opens the feed valve and allows main air into the branch chamber. When the pilot pressure decreases, the pilot chamber diaphragm rises, closing the feed valve. If the pilot chamber diaphragm rises enough, it lifts the bleed valve off the feed valve disc, allowing air to escape from the branch chamber through the vent, thus decreasing the branchline pressure. Main air is used only when branchline pressure must be increased and to supply the very small amount exhausted through the nozzle.

SIGNAL AMPLIFIER

In addition to the capacity amplifier, pneumatic systems also use a signal amplifier. Generally, modern amplifiers use diaphragms for control logic instead of levers, bellows, and linkages.

A signal amplifier increases the level of the input signal and provides increased flow. This amplifier is used primarily in sensor-controller systems where a small signal change from a sensor must be amplified to provide a proportional branchline pressure. The signal amplifier must be very sensitive and accurate, because the input signal from the sensor may change as little as 0.74 kPa per kelvin.

Another use for a signal amplifier is to multiply a signal by two to four times so a signal from one controller can operate several actuators in sequence.

FEED AND BLEED SYSTEM

The “feed and bleed” (sometimes called “non bleed”) system of controlling branchline pressure is more complicated than the nozzle-flapper assembly but theoretically uses less air. The nozzle-flapper system exhausts some air through the nozzle continually, whereas the feed and bleed system exhausts air only when the branchline pressure is being reduced. Since modern nozzle-flapper devices consume little air, feed and bleed systems are no longer popular.

The feed and bleed system consists of a feed valve that supplies main air to the branch line and a bleed valve that exhausts air from the branch line (Fig. 5). Each valve consists of a ball nested on top of a tube. Some pneumatic controllers use pressure balance diaphragm devices in lieu of springs and valves. A spring in the tube continually tries to force the ball up. The lever holds the ball down to form a tight seal at the end of the tube. The feed and bleed valves cannot be open at the same time.

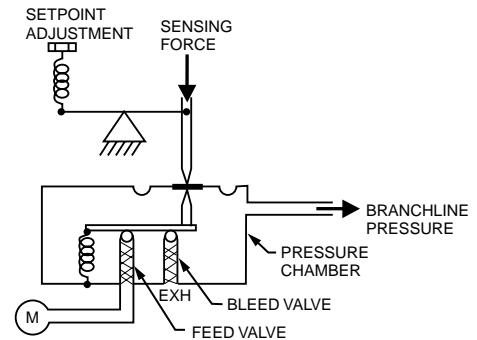

C2382-1

Fig. 5. Feed and Bleed System.

A force applied by the sensing element at the sensor input point is opposed by the setpoint adjustment spring and lever. When the sensing element pushes down on the lever, the lever pivots on the bleed ball and allows the feed ball to rise, which allows main air into the chamber. If the sensing element reduces its force, the other end of the lever rises and pivots on the feed ball, and the bleed ball rises to exhaust air from the system. The sensor can be any sensing element having enough force to operate the system.

SENSING ELEMENTS

BIMETAL

A bimetal sensing element is often used in a temperature controller to move the flapper. A bimetal consists of two strips of different metals welded together as shown in Figure 6A. As the bimetal is heated, the metal with the higher coefficient of expansion expands more than the other metal, and the bimetal warps toward the lower-coefficient metal (Fig. 6B). As the temperature falls, the bimetal warps in the other direction (Fig. 6C).

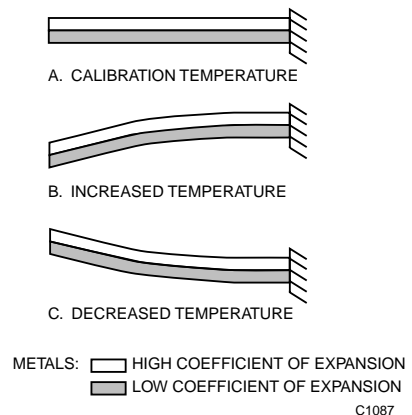

C1087

Fig. 6. Bimetal Sensing Element.

A temperature controller consists of a bimetal element linked to a flapper so that a change in temperature changes the position of the flapper. Figure 7 shows a direct-acting thermostat (branchline pressure increases as temperature increases) in which the branchline pressure change is proportional to the temperature change. An adjustment screw on the spring adjusts the temperature at which the controller operates. If the tension is increased, the temperature must be higher for the bimetal to develop the force necessary to oppose the spring, lift the flapper, and reduce the branch pressure.

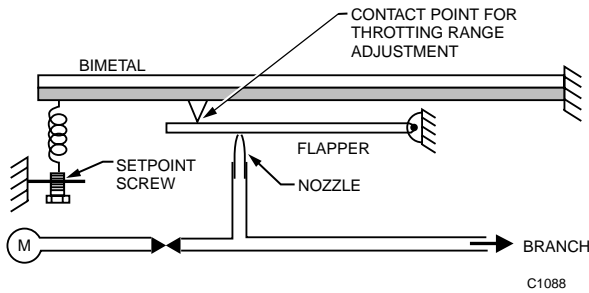

Fig. 7. Temperature Controller with Bimetal Sensing Element.

ROD AND TUBE

The rod-and-tube sensing element consists of a brass tube and an Invar rod, as shown in Figure 8. The tube expands and contracts in response to temperature changes more than the rod. The construction of the sensor causes the tube to move the rod as the tube responds to temperature changes. One end of the rod connects to the tube and the other end connects to the flapper spring to change the force on the flapper.

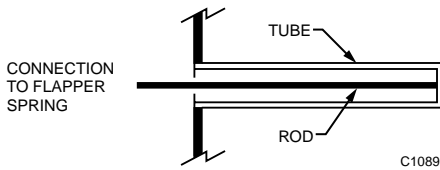

Fig. 8. Rod-and-Tube Insertion Sensor.

On a rise in temperature, the brass tube expands and draws the rod with it. The rod pulls on the flapper spring which pulls the flapper closed to the nozzle. The flapper movement decreases the air-bleed rate, which increases branchline pressure.

REMOTE BULB

The remote-bulb sensing element has as measuring element made up of a capillary and bulb filled with a liquid or vapor (Fig. 9). On an increase in temperature at the bulb, the liquid or vapor expands through the capillary tubing into the

diaphragm chamber. The expansion causes the diaphragm pad to push the pin toward the lever, which moves the flapper to change the branchline pressure.

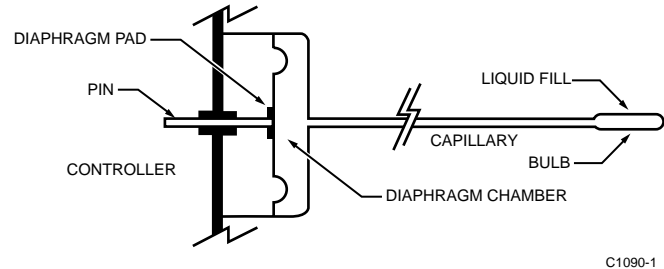

Fig. 9. Remote-Bulb Temperature Sensor.

Remote-bulb temperature sensors are used in bleed-type controllers. Capillary length of up to 2.5 meters are normally used for inserting the bulb in duct, tank, or pipe.

AVERAGING ELEMENT

The averaging-element sensor is similar to the remote-bulb sensor except that it has no bulb and the whole capillary is the measuring element. The long, flexible capillary has a slightly wider bore to accommodate the equivalent liquid fill that is found in a remote-bulb sensor. The averaging-element sensor averages temperatures along its entire length and is typically used to measure temperatures across the cross section of a duct in which two air streams may not mix completely.

THROTTLING RANGE ADJUSTMENT

A controller must always have some means to adjust the throttling range (proportional band). In a pneumatic controller, the throttling range is the change at the sensor required to change the branchline pressure 70 kPa. The setpoint is usually at the center of the throttling range. For example, if the throttling range of a temperature controller is 2 kelvins and the setpoint is 22°C, the branchline pressure is 20 kPa at 21°C, 55 kPa at 22°C, and 90 kPa at 23°C for a direct acting controller.

In all pneumatic systems except the sensor-controller system, the throttling range is adjusted by changing the effective length of a lever arm. In Figure 7, the throttling range is changed by moving the contact point between the bimetal and the flapper. (For information on adjusting the throttling range in a sensor-controller system, see SENSOR-CONTROLLER SYSTEMS.)

RELAYS AND SWITCHES

Relays are used in control circuits between controllers and controlled devices to perform a function beyond the capacity of the controllers. Relays typically have diaphragm logic

construction (Fig. 10) and are used to amplify, reverse, average, select, and switch controller outputs before being sent to valve and damper actuators.

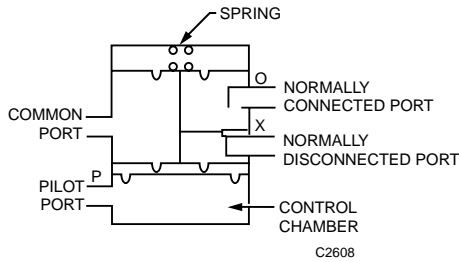

Fig. 10. Typical Switching Relay.

The controlling pressure is connected at the pilot port (P), and pressures to be switched are connected at the normally connected port (O) or the normally disconnected port (X). The operating point of the relay is set by adjusting the spring pressure at the top of the relay.

When the pressure at the pilot port reaches the relay operating point, it pushes up on the diaphragm in the control chamber and connects pressure on the normally disconnected port (X) to the common port as shown. If the pilot pressure falls below the relay setpoint, the diaphragm moves down, blocks the normally disconnected (X) port, and connects the normally connected port (O) to the common port.

AIR SUPPLY EQUIPMENT

GENERAL

A pneumatic control system requires a supply of clean, dry, compressed air. The air source must be continuous because many pneumatic sensors, controllers, relays, and other devices bleed air. A typical air supply system includes a compressor, an air dryer, an air filter, a pressure reducing valve, and air tubing to the control system (Fig. 11).

The following paragraphs describe the compressor, filter, pressure reducing valves, and air drying techniques. For information on determining the moisture content of compressed air, refer to the General Engineering Data section.

AIR COMPRESSOR

The air compressor provides the power needed to operate all control devices in the system. The compressor maintains pressure in the storage tank well above the maximum required in the control system. When the tank pressure goes below a minimum setting (usually 480 to 620 kPa), a pressure switch starts the compressor motor. When the tank pressure reaches a high-limit setting, the pressure switch stops the motor. A standard tank is typically large enough so that the motor and compressor operate no more than 50 percent of the time, with up to twelve motor starts per hour.

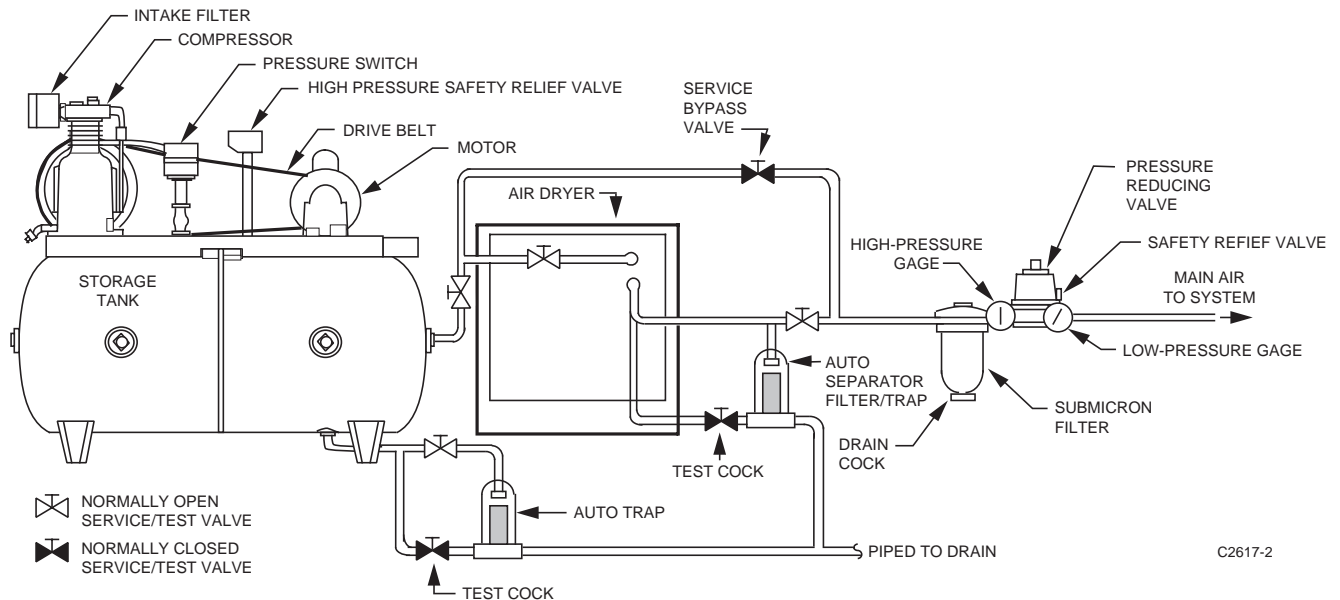

Fig. 11. Typical Air Supply.

Some applications require two compressors or a dual compressor. In a dual compressor, two compressors operate alternately, so wear is spread over both machines, each capable of supplying the average requirements of the system without operating more than half the time. In the event of failure of one compressor, the other assumes the full load.

Contamination in the atmosphere requires a compressor intake filter to remove particles that would damage the compressor pump. The filter is essential on oil-less compressors because a contaminated inlet air can cause excessive wear on piston rings. The intake filter is usually located in the equipment room with the compressor, but it may be located outdoors if clean outdoor air is available. After the air is compressed, cooling and settling actions in the tank condense some of the excess moisture and allow fallout of the larger oil droplets generated by the compressor pump.

A high pressure safety relief valve which opens on excessively high tank pressures is also required. A hand valve or automatic trap periodically blows off any accumulated moisture, oil residue, or other impurities that collect in the bottom of the tank.

AIR DRYING TECHNIQUES

GENERAL

Air should be dry enough to prevent condensation. Condensation causes corrosion that can block orifices and valve mechanisms. In addition, dry air improves the ability of filters to remove oil and dirt.

Moisture in compressed air is removed by increasing pressure, decreasing temperature, or both. When air is compressed and cooled below its saturation point, moisture condenses. Draining the condensate from the storage tank causes some drying of the air supply, but an air dryer is often required.

An air dryer is selected according to the amount of moisture in the air and the lowest temperature to which an air line will be exposed. For a chart showing temperature and moisture content relationships at various air pressures, refer to the General Engineering Data section.

DRY AIR REQUIREMENT

The coldest ambient temperature to which tubing is exposed is the criterion for required dryness, or dew point. Dew point is the temperature at which moisture starts to condense out of the air.

The coldest winter exposure is normally a function of outdoor air temperature. Summer exposure is normally a function of temperature in cold air ducts or air conditioned space. The typical coldest winter application is an air line and control device (e.g., damper actuator) mounted on a rooftop air handling unit and exposed to outdoor air temperatures (Fig. 12). The second coldest winter exposure is an air line run in a furred ceiling or outside wall.

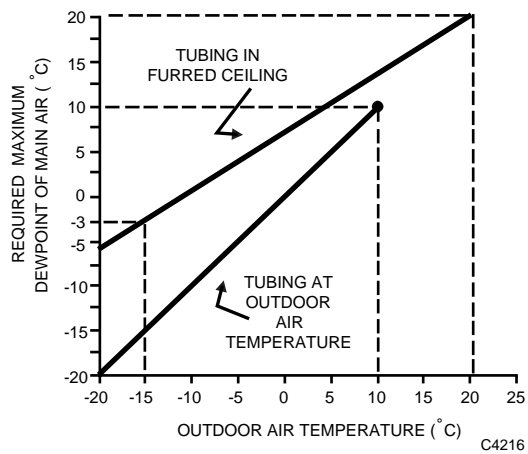

Fig. 12. Winter Dew Point Requirement.

A typical summer minimum dew point application is a cold air plenum. Figure 13 shows a 10°C plenum application along with winter requirements for a year-round composite.

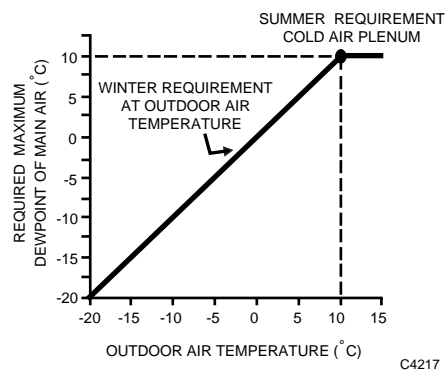

Fig. 13. Twelve-Month Composite Dew Point Requirement.

CONDENSING DRYING

The two methods of condensing drying are high-pressure drying and refrigerant drying.

High-Pressure Drying

High-pressure drying may be used when main air piping is kept away from outside walls and chilling equipment. During compression and cooling to ambient temperatures, air gives up moisture which then collects in the bottom of the storage tank. The higher the tank pressure, the greater the amount of moisture that condenses. Maintaining a high pressure removes the maximum amount of moisture. The compressor should have a higher operating pressure than is required for air supply purposes only. However, higher air pressure requires more energy to run the compressor. The tank must include a manual drain valve or an automatic trap to continually drain off accumulated moisture. With tank pressures of 480 to 620 kPa, a dew point of approximately 21°C at 140 kPa can be obtained.

Refrigerant Drying

Lowering air temperature reduces the ability of air to hold water. The refrigerated dryer (Fig. 14) is the most common means of obtaining dry, compressed air and is available in several capacities. It provides the greatest system reliability and requires minimal maintenance.

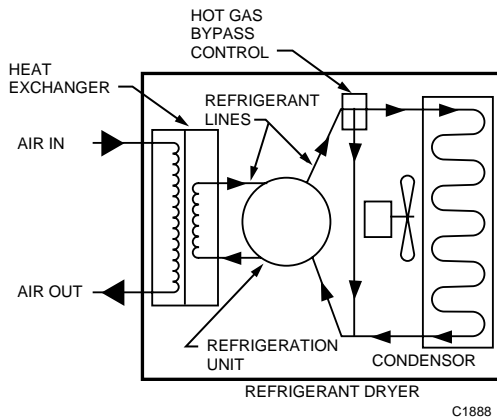

Fig. 14. Typical Refrigerant Dryer Airflow Diagram.

The refrigerant dryer uses a non cycling operation with a hot gas bypass control on the refrigerant flow to provide a constant dew point of approximately 2°C at the tank pressure. The refrigeration circuit is hermetically sealed to prevent loss of refrigerant and lubricant and to protect against dirt.

The heat exchanger reduces the temperature of the compressed air passing through it. A separator/filter condenses both water and oil from the air and ejects the condensate through a drain. A temperature-sensing element controls the operation of the refrigeration system to maintain the temperature in the exchanger.

With a dew point of 2°C and an average compressor tank pressure of 550 kPa, air is dried to a dew point of -11°C at 139 kPa. Under severe winter conditions and where piping and devices are exposed to outside temperatures, the -11°C dew point may not be low enough.

DESICCANT DRYING

A desiccant is a chemical that removes moisture from air. A desiccant dryer is installed between the compressor and the PRV. Dew points below -120°C are possible with a desiccant dryer. The desiccant requires about one-third of the process air to regenerate itself, or it may be heated. To regenerate, desiccant dryers may require a larger compressor to produce the needed airflow to supply the control system and the dryer.

It may be necessary to install a desiccant dryer after the refrigerant dryer in applications where the -11°C dew point at 138 kPa mainline pressure does not prevent condensation in air lines (e.g., a roof-top unit exposed to severe winters).

The desiccant dryer most applicable to control systems uses the adsorbent principle of operation in which porous materials attract water vapor. The water vapor is condensed and held as a liquid in the pores of the material. The drying action continues until the desiccant is saturated. The desiccant is regenerated by removing the moisture from the pores of the desiccant material. The most common adsorbent desiccant material is silica gel, which adsorbs over 40 percent of its own weight in water and is totally inert. Another type of adsorbent desiccant is the molecular sieve.

A desiccant is regenerated either by heating the desiccant material and removing the resulting water vapor from the desiccant chamber or by flushing the desiccant chamber with air at a lower vapor pressure for heatless regeneration. To provide a continuous supply of dry air, a desiccant dryer has two desiccant chambers (Fig. 15). While one chamber is being regenerated, the other supplies dry air to the system. The cycling is accomplished by two solenoid valves and an electric timer. During one cycle, air passes from the compressor into the left desiccant chamber (A). The air is dried, passes through the check valve (B), and flows out to the PRV in the control system.

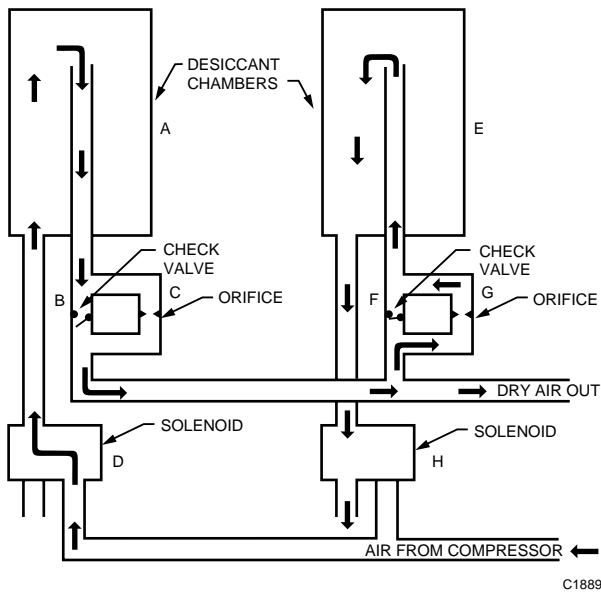

Fig. 15. Typical Heatless Desiccant Dryer Airflow Diagram.

Simultaneously, some of the dried air passes through the orifice (G) to the right desiccant chamber (E). The air is dry and the desiccant chamber is open to the atmosphere, which reduces the chamber pressure to near atmospheric pressure. Reducing the air pressure lowers the vapor pressure of the air below that of the desiccant, which allows the moisture to transfer from the desiccant to the air. The timer controls the cycle, which lasts approximately 30 minutes.

During the cycle, the desiccant in the left chamber (A) becomes saturated, and the desiccant in the right chamber (E) becomes dry. The timer then reverses the flow by switching both of the solenoid valves (D and H). The desiccant in the right chamber (E) then becomes the drying agent connected to the compressor while the desiccant in the left chamber (A) is dried.

The process provides dry air to the control system continually and requires no heat to drive moisture from the desiccant. A fine filter should be used after the desiccant dryer to filter out any desiccant discharged into the air supply.

PRESSURE REDUCING VALVE STATION

The pressure reducing valve station is typically furnished with an air filter. The filter, high-pressure gage, high pressure relief valve, pressure reducing valve (PRV), and low-pressure gage are usually located together at one point in the system and may be mounted directly on the compressor. The most important elements are the air filter and the PRV.

AIR FILTER

The air filter (Fig. 16) removes solid particulate matter and oil aerosols or mist from the control air.

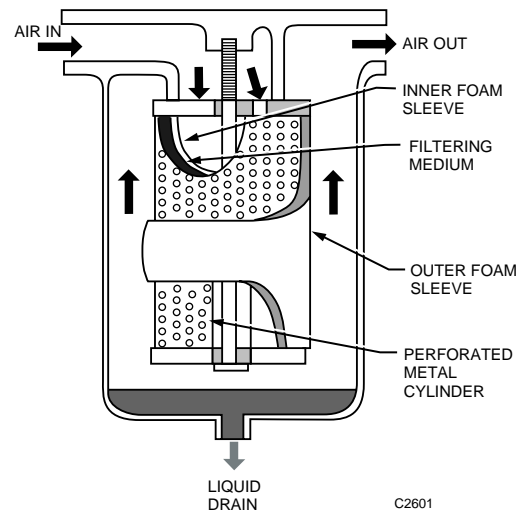

Fig. 16. Typical Air Filter.

Oil contamination in compressed air appears as a gas or an aerosol. Gaseous oil usually remains in a vapor state throughout the system and does not interfere with operation of the controls. Aerosols, however, can coalesce while flowing through the system, and turbulence can cause particles to collect in device filters, orifices, and small passages.

Many filters are available to remove solids from the air. However, only an oil-coalescing filter can remove oil aerosols from control air. An oil coalescing filter uses a bonded fibrous material to combine the small particles of oil mist into larger droplets. The coalesced liquids and solids gravitate to the bottom of the outer surface of the filter material, drop off into a sump, and are automatically discharged or manually drained.

The oil coalescing filter continues to coalesce and drain off accumulated oil until solid particles plug the filter. An increase in pressure drop across the filter (to approximately 70 kPa) indicates that the filter element needs replacement. For very dirty air, a 0.005 millimeter prefilter filters out large particles and increases the life of the final filter element.

PRESSURE REDUCING VALVES

A pressure reducing valve station can have a single-pressure reducing valve or a two-pressure reducing valve, depending on the requirements of the system it is supplying.

Single-Pressure Reducing Valve

After it passes through the filter, air enters the PRV (Fig. 11). Inlet pressure ranges from 415 to 1035 kPa, depending on tank pressures maintained by the compressor. Outlet pressure is adjustable from 0 to 175 kPa, depending on the control air requirements. The normal setting is 140 kPa.

A safety relief valve is built into some PRV assemblies to protect control system devices if the PRV malfunctions. The valve is typically set to relieve downstream pressures above 165 kPa.

THERMOSTATS

Thermostats are of four basic types:

- A low-capacity, single-temperature thermostat is the basic nozzle-flapper bleed-type control described earlier. It is a bleed, one-pipe, proportional thermostat that is either direct or reverse acting.
- A high-capacity, single-temperature thermostat is a low-capacity thermostat with a capacity amplifier added. It is a pilot-bleed, two-pipe, proportioning thermostat that is either direct or reverse acting.
- A dual-temperature thermostat typically provides occupied/unoccupied control. It is essentially two thermostats in one housing, each having its own bimetal sensing element and setpoint adjustment. A valve unit controlled by mainline pressure switches between the occupied and unoccupied mode. A manual override lever allows an occupant to change the thermostat operation from unoccupied operation to occupied operation.

Two-Pressure Reducing Valve

A two-pressure reducing valve is typically set to pass 90 or 124 kPa to the control system, as switched by a pilot pressure. The two-pressure reducing valve is the same as the single-pressure reducing valve with the addition of a switchover diaphragm and switchover inlet to accept the switchover pressure signal. Switchover to the higher setting occurs when the inlet admits main air into the switchover chamber. Exhausting the switchover chamber returns the valve to the lower setting.

The switchover signal is typically provided by an E/P relay or a two-position diverting switch. An automatic time clock can operate an E/P relay to switch the main pressure for a day/night control system. A diverting switch is often used to manually switch a heating/cooling system.

In many applications requiring two-pressure reducing valves, a single-pressure reducing valve is also required to supply single-pressure controllers which do not perform well at low pressures. Higher dual pressure systems operating at 140 and 170 kPa are sometimes used to eliminate the need and expense of the second PRV.

- A dual-acting (heating/cooling) thermostat is another two-pipe, proportioning thermostat that has two bimetal sensing elements. One element is direct acting for heating control, and the other, reverse acting for cooling control. Switchover is the same as for the dual-temperature thermostat but without manual override.

Other thermostats are available for specific uses. Energy conservation thermostats limit setpoint adjustments to reasonable minimums and maximums. Zero energy band thermostats provide an adjustable deadband between heating and cooling operations.

The thermostat provides a branchline air pressure that is a function of the ambient temperature of the controlled space and the setpoint and throttling range settings. The throttling range setting and the setpoint determine the span and operating range of the thermostat. The nozzle-flapper-bimetal assembly

maintains a fixed branchline pressure for each temperature within the throttling range (Fig. 17). The forces within the nozzle-flapper-bimetal assembly always seek a balanced condition against the nozzle pressure. If the setpoint is changed, the forces in the lever system are unbalanced and the room ambient temperature must change in a direction to cause the bimetal to rebalance the lever system.

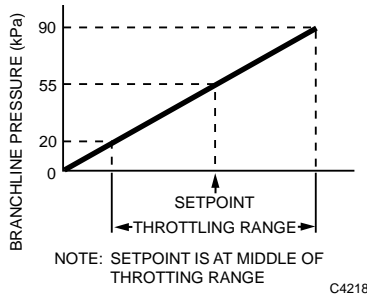

Fig. 17. Relationship between Setpoint, Branchline Pressure, and Throttling Range.

For example, if the setpoint of a direct acting thermostat is increased, the bimetal reduces the force applied to the flapper

and raises the flapper off the nozzle. This movement causes the branchline pressure to bleed down and a heating valve to open. Heat enters the space until the temperature at the thermostat increases and the force of the bimetal is again in equilibrium with the opposing force of the pressure at the nozzle. Decreasing the setpoint causes the reverse to occur.

The throttling range adjustment provides the means for changing the effective length of the cantilever bimetal in the lever system. When the throttling range adjustment is positioned directly over the nozzle, the force of the bimetal increases and a narrow throttling range or very high sensitivity results. For example, a change in temperature of 0.5 kelvins could result in a branchline pressure change of 35 kPa.

When the throttling range adjustment is moved toward the end of the bimetal and away from the nozzle, the force of the bimetal is reduced. This reduction requires a greater temperature change at the bimetal to throttle the flapper over the nozzle. The result is a wider throttling range or very low sensitivity. For example, a temperature change of 0.5 kelvins could result in a branchline pressure change of only 7 kPa.

CONTROLLERS

GENERAL

A controller is the same as a thermostat except that it may have a remote sensing element. A controller typically measures and controls temperature, humidity, airflow, or pressure. Controllers can be reverse or direct acting, proportional or two-position, single or two pressure, and bleed, feed and bleed, or pilot bleed.

A two-position controller changes branchline pressure rapidly from minimum to maximum (or from maximum to minimum) in response to changes in the measured condition, thus providing ON/OFF operation of the controlled device.

A proportional controller changes branchline pressure incrementally in response to a change in the measured condition, thus providing modulating operation of the controlled device.

A proportional-integral (PI) controller adds to the proportional controller a component that takes offset into account. The integral component eliminates the control point offset from the setpoint.

Bleed-type controllers can be used in one-pipe or two-pipe configurations. In a one-pipe system (Fig. 18), the main air goes through a restrictor to the controller and actuator in the most expeditious routing. In a two-pipe system (Fig. 19), the

main air goes into the controller, through an internal restrictor in the controller, and out of the controller through a branch line to the actuator. All pilot-bleed and feed-and-bleed controllers are two pipe.

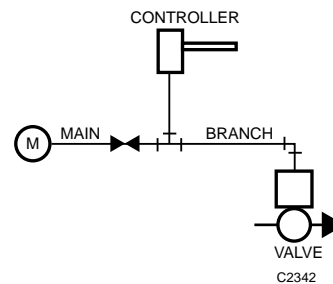

Fig. 18. One-Pipe Controller System.

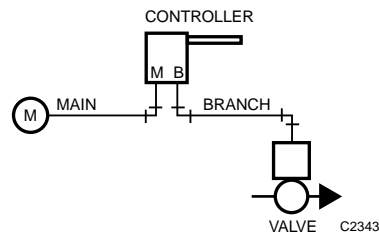

Fig. 19. Two-Pipe Controller System.

Controllers may also be classified as single-pressure or two-pressure controllers. Single-pressure controllers use a constant main air pressure. Two-pressure controllers use a main air pressure that is alternately switched between two pressures, such as 90 and 124 kPa. For example, occupied/unoccupied controllers automatically change setpoint from a occupied setting at a mainline pressure of 90 kPa to a lowered unoccupied setting at 124 kPa. Heating/cooling controllers change from reverse acting at mainline air pressure of 90 kPa for cooling to direct acting at 124 kPa for heating.

TEMPERATURE CONTROLLERS

Temperature controllers can be one- or two-pipe. The sensing element is typically bimetal, liquid filled remote bulb, or liquid filled averaging capillary tube. Dimensional change of the element with temperature change results in flapper position change and therefore, pilot and branch pressure change.

HUMIDITY CONTROLLERS

Principles that apply to temperature controllers also apply to humidity controllers. The primary difference between temperature and humidity controllers is in the type of sensing element. The sensing element in a humidistat is usually a band of moisture-sensitive nylon. The nylon expands and contracts with changes in the relative humidity of the air.

The humidistat can be used in a one-pipe or two-pipe configuration and is available as either a bleed-type humidistat or a two-pipe capacity humidistat using a capacity amplifier. The humidistat may be direct or reverse acting. The high-capacity humidistat has a capacity amplifier.

PRESSURE CONTROLLERS

Pressure controllers can be divided into two classes according to the pressure range of the measured variable. High-pressure controllers measure and control high pressures or vacuums measured in kilopascals or pascals (e.g., steam or water pressures in an air conditioning system). Low-pressure controllers measure and control low pressures and vacuums measured in kilopascals or pascals (e.g., pressure in an air duct).

High- and low-pressure controllers have different size diaphragms. In both types, one side of the diaphragm is

connected to the pressure to be controlled, and the other side is connected to a reference pressure. Pressures can be measured in respect to atmospheric pressure or another pressure source. The low-pressure controller is available in both bleed-type and pilot-bleed designs.

Figure 20 shows a schematic of a bleed-type, low-pressure controller. The direct-acting pressure sensor measures static pressure from a pressure pickup located in a duct. A reference pressure, from a pickup located outside the duct, is applied to the other side of the diaphragm.

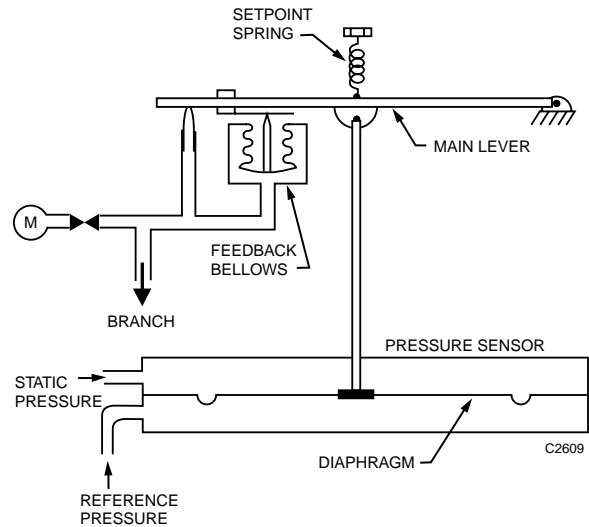

Fig. 20. Bleed-Type Static Pressure Controller.

On an increase in static pressure, the increased force on the diaphragm exceeds the force of the setpoint spring, pulling the main lever downward. A setpoint adjustment screw determines the tension of the setpoint spring. As the main lever is pulled downward, it moves closer to the nozzle, restricts the airflow through the nozzle, and increases the pressure in the branch. The action continues until the pressure on the feedback bellows balances the static pressure on the diaphragm.

On a decrease in static pressure, or if the static pressure sensor is piped for reverse action (high- and low-pressure pickups reversed), the diaphragm moves upward to move the main lever away from the nozzle and reduce the pressure in the branch.

For differential pressure sensing, the two pressure pickup lines connect to opposite sides of the pressure sensor diaphragm.

SENSOR-CONTROLLER SYSTEMS

A sensor-controller system is made up of a pneumatic controller, remote pneumatic sensors, and a final control element. The controller provides proportional or proportional-integral control of temperature, humidity, dew point, or pressure in HVAC systems. Sensors do not have a setpoint adjustment and provide a linear 20 to 100 kPa signal to the controller over a fixed sensor range. The controller compares the sensor input signal with the setpoint signal. The difference is the pilot input to a signal amplifier, which provides a branchline pressure to the controlled device. Thus the controller acts as a general-purpose pneumatic amplifier.

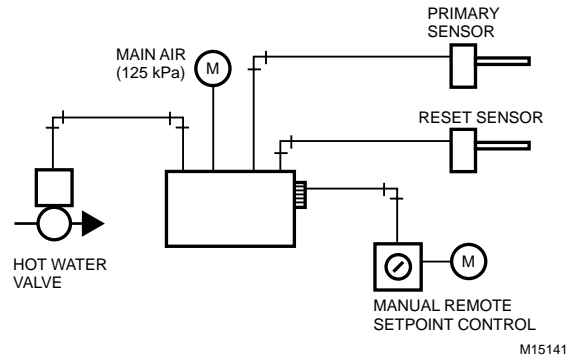

Fig. 22. Dual-Input Controller with Manual Remote Setpoint.

PNEUMATIC CONTROLLERS

Controllers generally use diaphragm logic, which allows flexible system application, provides more accurate control, and simplifies setup and adjustment for the needs of each system. Controllers may be proportional only or proportional-integral (PI). The integral function is also called “automatic reset”. Proportional and PI controllers are available with single-sensor input or dual-sensor input for resetting the primary sensor setpoint from a second sensor. They are also available with integral or remote setpoint adjustment.

The single-input controller consists of a signal amplifier feeding a capacity amplifier. The capacity amplifier is discussed under PILOT BLEED SYSTEM. A dual-input controller has inputs from a primary temperature sensor and a reset temperature sensor. The reset sensor resets controller setpoint. Reset can be negative or positive.

Figure 21 depicts a single-input controller as it would appear in a simple application. Figure 22 depicts a dual-input controller with manual remote setpoint control. In Figures 21 and 22 the sensors are fed restricted main air from the controllers. Where sensors are located extremely remote from the controller, a remote restrictor may be required.

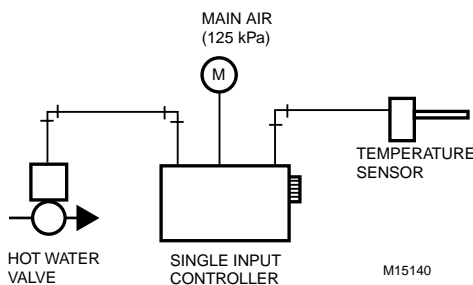

Fig. 21. Single-Input Controller.

PROPORTIONAL-INTEGRAL (PI) CONTROLLERS

Variations of single-input and dual-input controllers can provide proportional-integral (PI) control. PI controllers are used in critical applications that require closer control than a proportional controller. A PI controller provides close control by eliminating the deviation from setpoint (offset) that occurs in a proportional controller system. PI controllers are similar to the controllers in Figures 21 and 22 and have an additional knob for adjusting the integral reset time.

CONTROLLER ADJUSTMENTS

Controller operation is adjusted in the following ways:

- Adjusting the setpoint
- Changing between direct and reverse control action
- Adjusting the proportional band (throttling range)
- Adjusting the reset authority
- Adjusting the integral control reset time

The setpoint can be manually adjusted with a dial on the controller. Remote setpoint adjustment is available for all controllers. Control action may be direct or reverse, and is field adjustable. The proportional band setting is typically adjustable from 2.5 to 50 percent of the primary sensor span and is usually set for the minimum value that results in stable control. In a sensor with a span of 110 kelvins, for example, the minimum setting of 2.5 percent results in a throttling range of 2.75 kelvins ($0.025 \times 110 = 2.75$ kelvins). A change of 2.75 kelvins is then required at the sensor to proportionally vary the controller branchline pressure from 20 to 90 kPa. A maximum setting of 50 percent provides a throttling range of 55 kelvins ($0.50 \times 110 = 55$ kelvins).

Reset authority, also called “reset ratio”, is the ratio of the effect of the reset sensor compared to the primary sensor. Figure 23 shows the effect of authority on a typical reset schedule. The authority can be set from 10 to 300 percent.

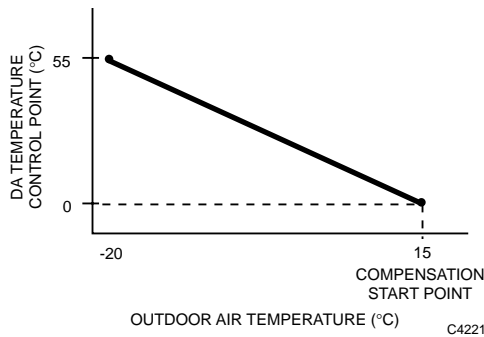

Fig. 23. Typical Reset Schedule for Discharge Air Control.

The integral control reset time determines how quickly the PI controller responds to a change in the controlled variable. Proportional correction occurs as soon as the controlled variable changes. The integral function is timed with the reset time adjustment. The reset time adjustment is calibrated from 30 seconds to 20 minutes. The proper setting depends on system response time characteristics.

PNEUMATIC SENSORS

Pneumatic sensors typically provide a direct acting 20 to 100 kPa pneumatic output signal that is proportional to the measured variable. Any change in the measured variable is reflected as a change in the sensor output. Commonly sensed variables are temperature, humidity, and differential pressure. The sensors use the same sensing elements and principles as the sensors in the controllers described earlier, but do not include setpoint and throttling range adjustments. Their throttling range is the same as their span.

A gage connected to the sensor output can be used to indicate the temperature, humidity, or pressure being sensed. The gage scale is calibrated to the sensor span.

Temperature sensors may be vapor-filled, liquid-filled, averaging capillary, or rod-and-tube. The controller usually provides restricted air to the sensor.

Humidity sensors measure the relative humidity of the air in a room (wall-mounted element) or a duct (insertion element). Nylon is typically used as the sensing element. Humidity sensors include temperature compensation and operate on a force-balance principle similar to a wall thermostat.

The low-pressure sensor measures duct static pressure and differential pressure. When the duct static pressure or the pressure differential increases, branchline pressure increases.

VELOCITY SENSOR-CONTROLLER

The velocity sensor-controller combines a highly sensitive air velocity sensor with a pneumatic controller to detect and control airflow regardless of system static pressure. It is used in air terminal units and other air handling systems. Reverse- and direct-acting models are available for normally closed and normally open dampers.

The velocity sensor measures actual velocity and does not require the conversion of velocity pressure to velocity. Although the sensor is typically used in duct air velocity applications, it can accurately sense velocities as low as 5 meters per second. Flow-limiting orifices inserted into the sensor sampling tube can measure velocity ranges up to 17.8 meters per second.

Figure 24 shows the operation of a velocity sensor. A restrictor supplies compressed air to the emitter tube located in the air stream to be measured. When no air is flowing in the duct, the jet of air from the emitter tube impinges directly on the collector tube and maximum pressure is sensed. Air flowing in the duct blows the air jet downstream and reduces the pressure on the collector tube. As the duct air velocity increases, less and less of the jet enters the collector tube. The collector tube is connected to a pressure amplifier to produce a usable output pressure and provide direct or reverse action.

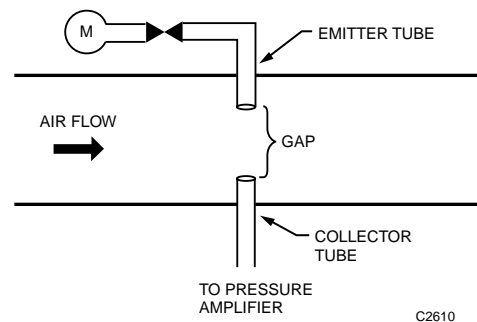

Fig. 24. Velocity Sensor Operation.

A controller connected to the pressure amplifier includes setpoints for maximum and minimum dual air velocity limits. This allows the air volume to be controlled between the limits by a thermostat or another controller.

Two models of the controller are available. One model operates with a one-pipe, bleed-type thermostat, and the other with a two-pipe thermostat. The two-pipe model also allows sequencing for reheat applications.

Figure 25 shows a typical application of a thermostat and velocity controller on a Variable Air Volume (VAV) terminal unit with hot water reheat. The thermostat senses a change in room temperature and resets the velocity setpoint of the velocity controller. The controller repositions the VAV damper to increase or decrease airflow accordingly. If a change in duct static pressure modifies the flow, the controller repositions the actuator to maintain the correct flow. The reheat valve operates only when the thermostat has reset the velocity setpoint down to minimum airflow and the thermostat calls for heating.

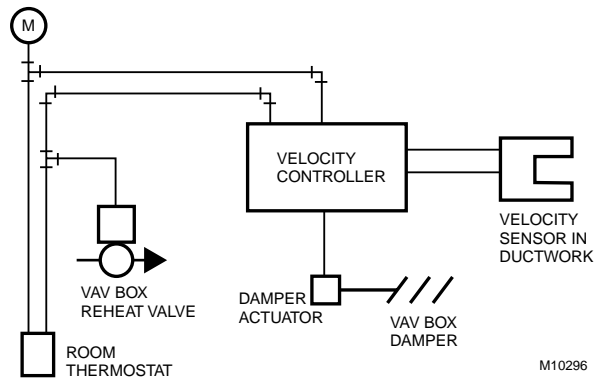

Fig. 25. VAV Box Velocity Controller Control System.

ACTUATORS AND FINAL CONTROL ELEMENTS

A pneumatic actuator and final control element such as a valve (Fig. 26) or damper (Fig. 27) work together to vary the flow of the medium passing through the valve or damper. In the actuator, a diaphragm and return spring move the damper push rod or valve stem in response to changes in branchline pressure.

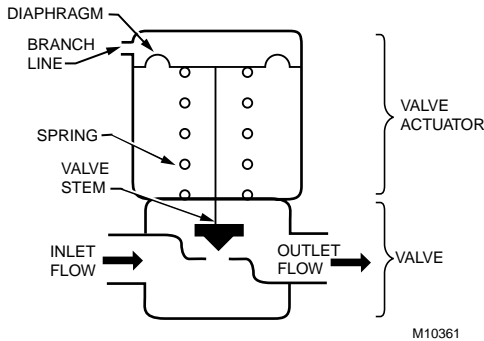

Fig. 26. Pneumatic Actuator and Valve.

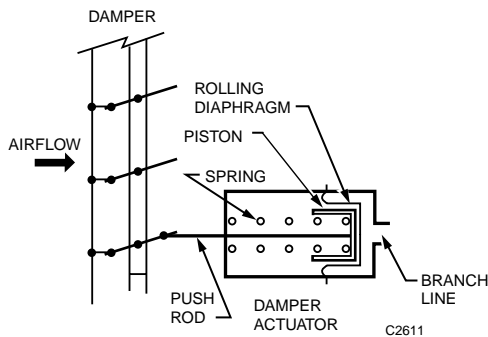

Fig. 27. Pneumatic Actuator and Damper.

ACTUATORS

GENERAL

Pneumatic actuators position damper blades and valve stems. A damper actuator typically mounts on ductwork or on the damper frame and uses a push rod and crank arm to position the damper blades (rotary action). A valve actuator mounts on the valve body and positions the valve stem directly (linear action) for a globe valve or rotary action via linkage for a butterfly valve. Valve actuator strokes typically are between 6 and 38 millimeters. Damper actuator strokes range from one to four inches (longer in special applications). In commercial pneumatic actuators, air pressure positions the actuator in one direction and a spring returns it the other direction.

Valve actuators are direct or reverse acting. Damper actuators are direct acting only. A direct-acting actuator extends on an increase in branchline pressure and retracts on a decrease in pressure. A reverse-acting actuator retracts on an increase in branchline pressure and extends on a decrease in pressure.

Pneumatic valve and damper actuator assemblies are termed “normally open” or “normally closed.” The normal position is the one assumed upon zero actuator air pressure. Three-way valves have both normally open (N.O.) and normally closed (N.C.) ports.

SPRING RANGES

Springs used in valve and damper actuators determine the start pressure and pressure change required for full movement of the actuator from open to closed, or from closed to open.

Actuators designed for special applications can move through the full range, open to closed or closed to open, on a limited change in pressure from the controller. Such actuators can provide a simple form of sequence control (e.g., operating heating and cooling valves from a single thermostat). Typical spring pressure ranges are 15-50 kPa, 55-85 kPa, and 20-90 kPa.

CONTROL VALVES

Single-seated globe valves (Fig. 28) are used where tight close-off is required. The valve body can be either direct acting or reverse acting. A direct-acting valve body allows flow with the stem up, while a reverse-acting valve body shuts off flow with the stem up. The combination of valve body and actuator (called the valve assembly) determines the normal valve stem position.

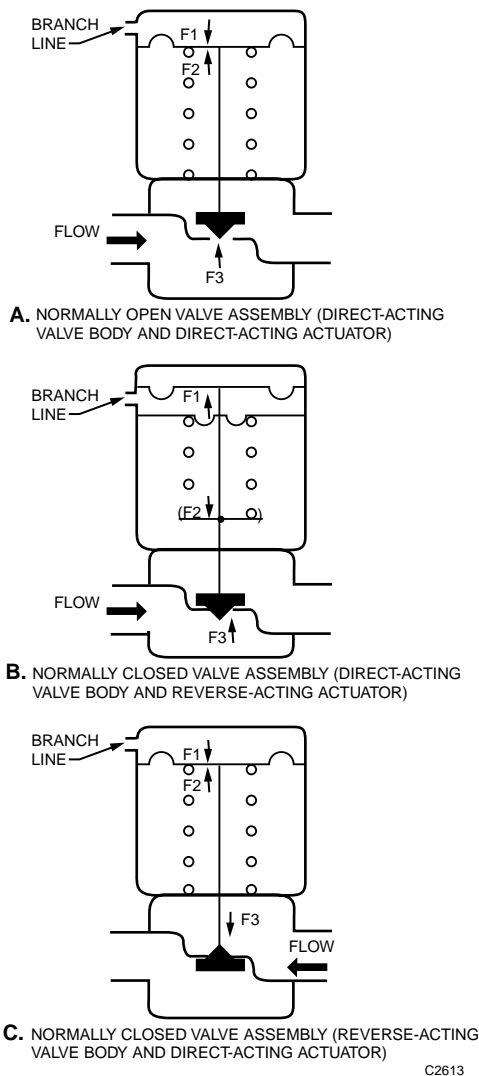

Fig. 28. Single-Seated Valves.

The position maintained by the valve stem depends on the balance of forces acting on it:

- Force F1 from the air pressure on the diaphragm
- Opposing force F2 from the actuator spring
- Controlled-medium force F3 acting on the valve disc and plug due to the difference between inlet and outlet pressures

An increase in controller branchline pressure increases force F1, (Fig. 28A), moving the diaphragm down and positions the valve stem toward closed until it has moved far enough that the sum of the spring force F2 and the controlled-medium force F3 increases balance the increased force F1 on the diaphragm. Conversely, a decrease in controller branchline air pressure in the diaphragm chamber of a direct-acting actuator decreases force F1, allowing forces F2 and F3 to push the diaphragm upward and move the valve stem toward the open position.

In Figure 28B, branchline pressure is applied on the bottom surface of the diaphragm. An increase in air pressure in the diaphragm chamber increases force F1 causing the actuator diaphragm to move upward and open the valve. Motion continues until the increase in pressure on the diaphragm plus the controlled-medium force F3 is balanced by the increase in spring compression (force F2). On a decrease in air pressure in the diaphragm chamber, the compressed spring moves the diaphragm down toward its normal position and the valve stem toward closed. A normally closed valve assembly usually has a lower close-off rating against the pressure of the controlled medium than a normally open valve because the spring force F2 is the only force available to close the valve.

In Figure 28C, an increase in branchline pressure in the actuator increases force F1 causing the diaphragm to move downward and open the valve. Motion continues until the increase in pressure on the diaphragm (force F1) plus the controlled-medium force F3 is balanced by the increase in spring compression (force F2). On a decrease in air pressure in the diaphragm chamber, the compressed-spring pressure moves the diaphragm up and the valve stem moves toward the closed position.

In a double-seated valve (Fig. 29), the controlled agent flows between the two seats. This placement balances the inlet pressures between the two discs of the plug assembly and reduces the actuator force needed to position the plug assembly. Double-seated valves generally do not provide tight close-off because one disc may seat before the other and prevent the other disc from seating tightly.

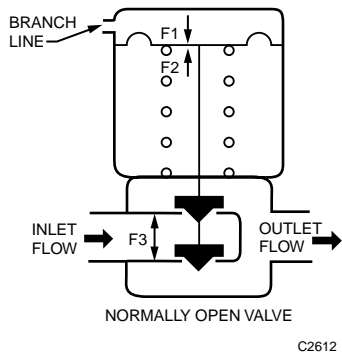

Fig. 29. Double-Seated Valve.

Figure 30 shows three-way globe valve assemblies. The mixing valve has two inlets and a common outlet. The diverting valve has a common inlet and two outlets.

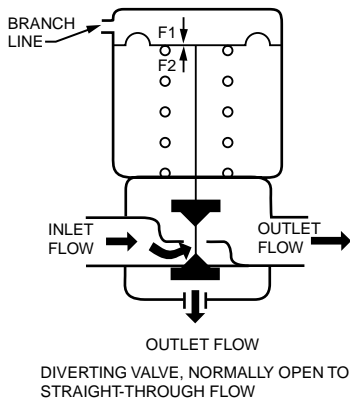
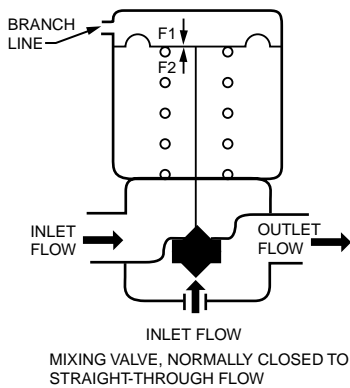

Fig. 30. Three-Way Valve Assemblies.

Three-way valves may be piped to be normally open or normally closed to the heating or cooling load. If a three-way valve has linear characteristics and the pressure differentials are equal, constant total flow is maintained through the common inlet or outlet port.

Two- and three-way butterfly valves can be operated by long stroke pneumatic actuators and appropriate linkage (Fig. 31).

One or two low pressure actuators powered directly by branchline pressure can operate butterfly valves up to about 300 millimeters, depending on the differential close-off rating of the valve. For other applications high pressure pneumatic cylinders can be used to provide the force required by the valve. A pneumatic positioner provides an appropriate high pressure signal to the cylinder based on a 20 to 100 kPa input signal.

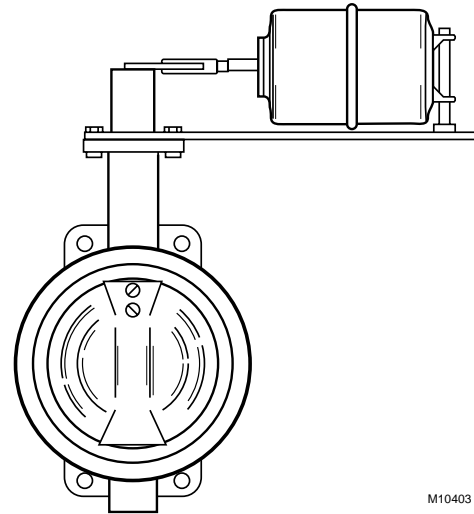

Fig. 31. Butterfly Valve Assembly.

For a more detailed discussion of valves, see the Valve Selection And Sizing section.

DAMPERS

Dampers control the flow of air in air-handling systems. The most common type of damper, a multiblade louver damper, can have parallel or opposed blades (Fig. 32).

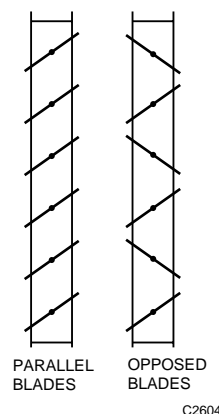

Fig. 32. Parallel- and Opposed-Blade Dampers.

Figure 33 shows normally open and normally closed parallel-blade dampers. A normally open damper returns to the open position with low air pressure in the actuator diaphragm chamber. An increase in branchline pressure forces the rolling diaphragm piston to move against the spring, and a decrease allows the compressed spring to force the piston and diaphragm back to the normal position. As with valve actuators, intermediate positions depend on a balance between the force of the control air pressure on the diaphragm and the opposing force of the actuator spring.

A normally closed damper returns to the closed position with low air pressure in the actuator diaphragm chamber. The way the damper blades, crank arm, and push rod are oriented during installation determines the normal (open or closed) position of the damper blades.

For a more detailed discussion of dampers, see the Damper Selection and Sizing section.

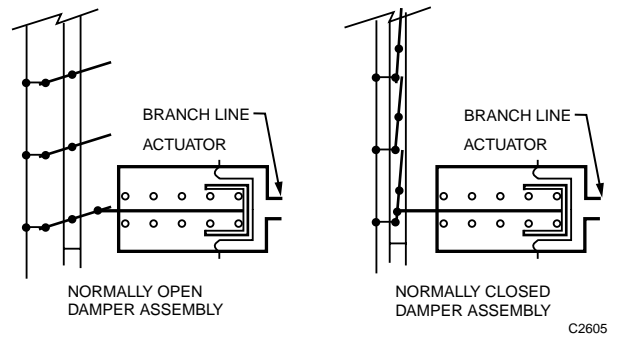

Fig. 33. Normally Open and Normally Closed Dampers.

RELAYS AND SWITCHES

In the following illustrations, common (C) and the normally connected port (O) are connected on a fall in pilot pressure (P) below the relay setpoint, and the normally disconnected port (X) is blocked (Fig. 34). On a rise in pilot pressure above the relay setpoint, C and X are connected and O is blocked.

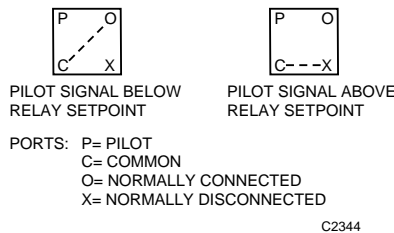

Fig. 34. Relay Port Connections.

SWITCHING RELAY

A switching relay requires a two-position pilot signal and is available with either single-pole, double-throw (spdt) or double-pole, double-throw (dpdt) switching action. Pneumatic heating

and cooling control systems use relays to switch a valve or damper actuator from one circuit to another or to positively open or close a device. Both spdt and dpdt switching relays are available with a variety of switching pressures.

Figure 35 shows a typical spdt switching relay application for heating/cooling operation in which the thermostat controls the heating/cooling coil valve. Seasonal mainline pressure changes cause the action of the thermostat to be reversed. A discharge low-limit control is switched into the control circuit for heating and out of the circuit for cooling. The switching is done from mainline pressure connected to the pilot port (P).

During the heating cycle, the 124 kPa mainline pressure is above the preset switching pressure. The common port (C) connects to the normally disconnected port (X), connecting the low-limit controller to the thermostat branchline to prevent discharge temperatures below the controller setting. The normally connected port (O) is blocked.

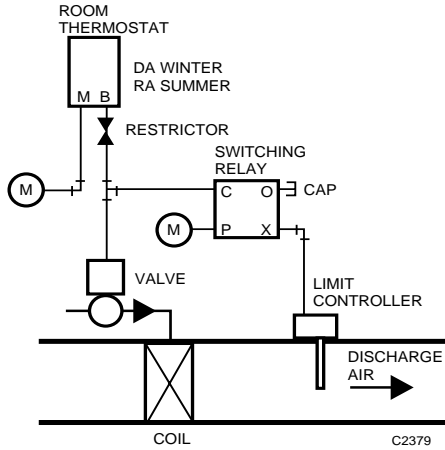

Fig. 35. Typical Switching Relay for Application.

During the cooling cycle, the 90 kPa mainline pressure at the pilot port (P) is below the minimum switching pressure of the preset limits. The common port (C) connects to the normally connected port (O), which is capped. The normally disconnected port (X) is closed and removes the low-limit controller from the system.

In a dpdt model, the common, normally connected, and normally disconnected ports are duplicated in the second switch section.

SNAP ACTING RELAY

The snap acting relay is a spdt switch that provides two-position switching action from a modulating signal and has an adjustable switching point. The switching differential is less than 7.0 kPa. The switching pressure is manually adjustable for 20 to 100 kPa operation.

Figure 36 shows a snap acting relay application. Operation is similar to the switching relay. When the branchline pressure from the outdoor air thermostat equals or exceeds the preset switchover pressure, the relay connects the normally disconnected port (X) and blocks the normally connected port (O) to deliver main air to the normally open heating valve and provide positive close off. When the outdoor air thermostat pressure drops below the relay setpoint, the normally disconnected port (X) is blocked and the normally connected port (O) connects to the common port (C) to connect the valve actuator to the room thermostat.

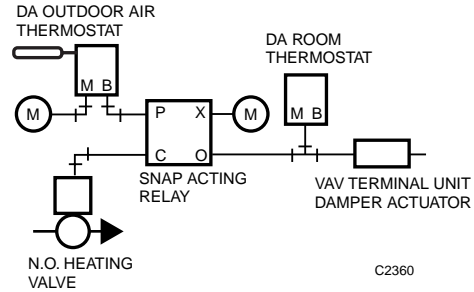

Fig. 36. Typical Application for Snap Acting Relay.

LOCKOUT RELAY

The lockout relay is a three-port relay that closes off one pressure signal when a second signal is higher. Figure 37 shows a typical application in which mixed air control becomes disabled when outdoor air temperature is higher than return air temperature. To prevent air from being trapped in the line between the lockout relay and the snap acting relay, a small bleed must be present either in the pilot chamber of the snap acting relay or in the line.

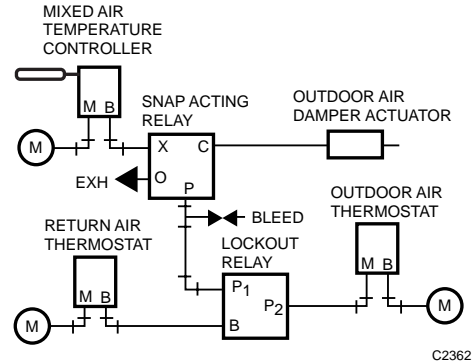

Fig. 37. Lockout Relay in Economizer Cycle.

Figure 38 shows the lockout relay used as a repeater. This application provides circuit isolation by repeating the pilot signal with a second air source.

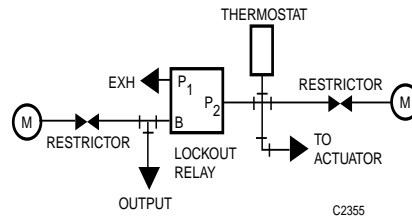

Fig. 38. Lockout Relay as Repeater.

HIGH-PRESSURE SELECTOR RELAY

The high-pressure selector relay is a three-port relay that transmits the higher of two input signals to the output branch. The high sensitivity of the relay allows it to be used in sensor lines with an accuracy of 1 to 1.5 degrees C.

The application shown in Figure 39 uses pressures from two zones and a high-pressure selector relay to determine control. A separate thermostat controls each zone damper. The thermostat that calls for the most cooling (highest branchline pressure) controls the cooling valve through the high-pressure selector relay.

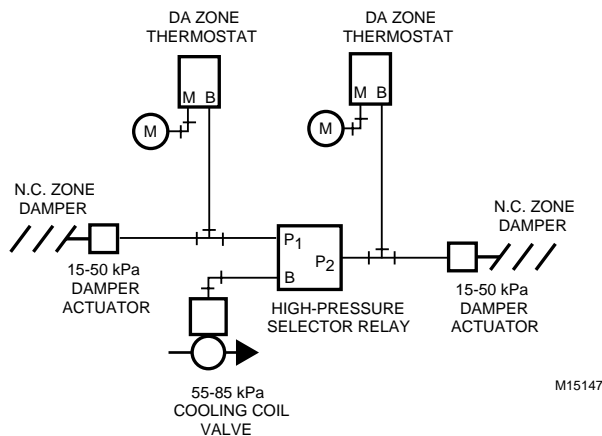

Fig. 39. Typical Application for High-Pressure Selector Relay.

LOAD ANALYZER RELAY

The load analyzer relay is a bleed-type, diaphragm-logic pressure selector. The relay selects the highest and lowest branch pressure from multiple inputs to operate final control elements (Fig. 41). The relay contains multiple diaphragms and control nozzles. Each input pressure connects to two diaphragms.

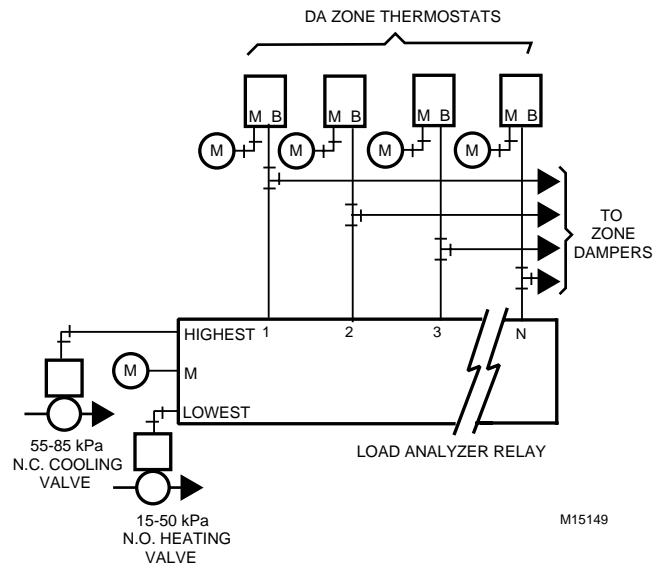

Fig. 41. Load Analyzer Relay in Multizone Air Unit Application.

LOW-PRESSURE SELECTOR RELAY

The low-pressure selector relay is a three-port relay that selects the lower of two input pressure signals and acts as a repeater for the lower of the two inputs. The relay requires an external restrictor on the input to the branch port. Figure 40 shows a low-pressure selector relay controlling the heating coil valve from the thermostat that calls for the most heat.

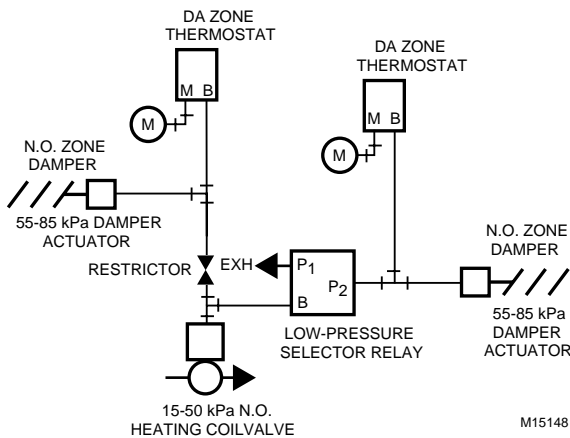
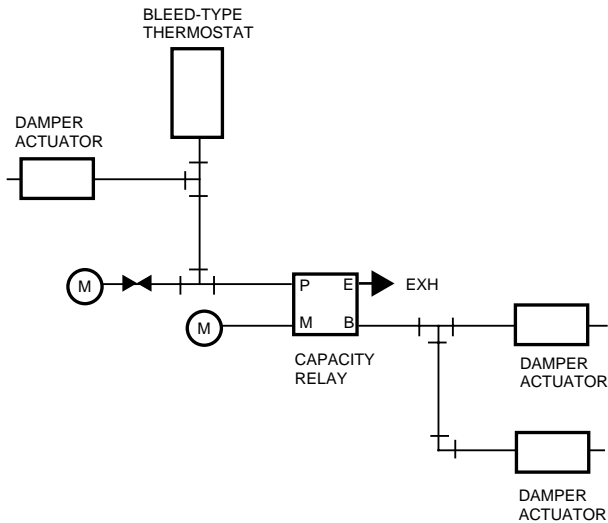

Fig. 40. Typical Application for Low-Pressure Selector Relay.

In Figure 41, the load analyzer relay selects the lowest pressure signal from the thermostat in the coldest zone and transmits that signal to a normally open heating valve. The relay transmits the highest pressure signal from the thermostat in the warmest zone to a normally closed cooling valve.

CAPACITY RELAY

The capacity relay is a direct-acting relay that isolates an input and repeats the input pressure with a higher capacity output. Figure 42 shows a capacity relay enabling a single bleed-type thermostat to operate multiple damper actuators quickly by increasing the output capacity of the thermostat.



C2365

Fig. 42. Typical Capacity Relay Application.

REVERSING RELAY

The reversing relay is a modulating relay with an output that decreases at a one-to-one ratio as the input signal increases. Figure 43 shows a reversing relay application. A falling temperature at the direct-acting thermostat causes the branchline pressure to decrease. The reversing relay branch pressure increases and opens the normally closed heating valve.

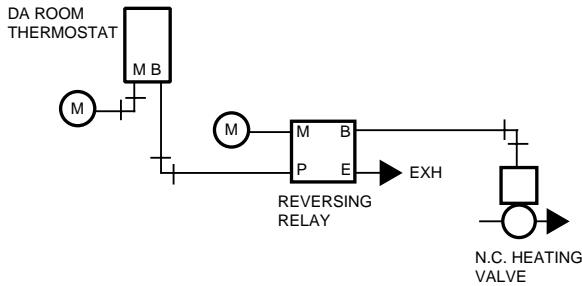

C2354

Fig. 43. Reversing Relay Application.

POSITIVE-POSITIONING RELAY

The positive-positioning relay (Fig. 44) mounts directly on a valve or damper actuator. The relay positions the valve or

damper precisely according to the branchline pressure from a thermostat or other controller, regardless of the load variations affecting the valve stem or damper shaft. The relay is typically used for large actuators for sequencing, or in applications requiring precise control.

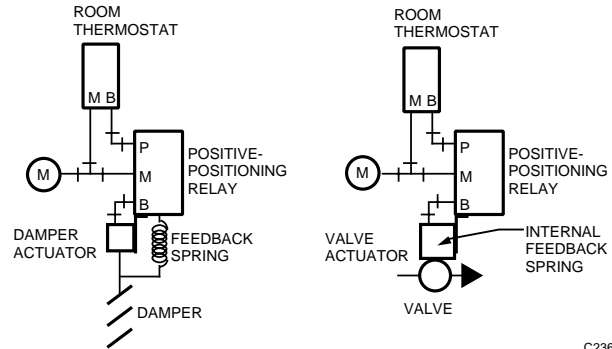

C2366

Fig. 44. Positive-Positioning Relay with Damper and Valve Actuators.

When the relay is connected to an actuator, the feedback spring produces a force proportional to the actual valve or damper position. The relay positions the actuator in proportion to the branchline input. If the connected load attempts to unbalance the required valve stem position, the relay either exhausts or applies main pressure to the actuator to correct the condition. If the valve or damper sticks or the load prevents proper positioning, the relay can apply the pressure required (up to full main pressure) or down to zero to correct the condition.

The positive-positioning relay also permits sequenced operation of multiple control valves or dampers from a single thermostat or controller. For example, a normally open heating valve and a normally closed outdoor air damper could be controlled from a single thermostat piloting relays on two actuators. Relays typically have a 20, 35, or 70 kPa input pressure span and an adjustable start pressure. As the space temperature rises into the low end of the thermostat throttling range, the heating valve positioner starts to close the valve.

AVERAGING RELAY

The averaging relay is a direct-acting, three-port relay used in applications that require the average of two input pressures to supply a controller input or to operate a controlled device directly.

Figure 45 shows an averaging relay in a typical application with two thermostat signals as inputs. The average of the thermostat signals controls a valve or damper actuator.

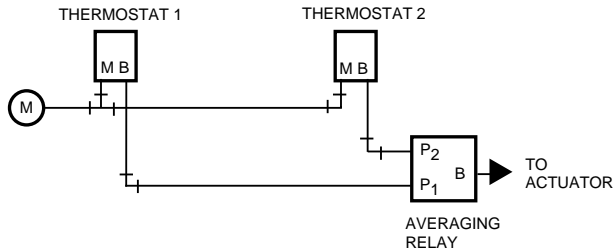

C2345

Fig. 45. Averaging Relay Application.

RATIO RELAY

The ratio relay is a four-port, non bleed relay that produces a modulating pressure output proportional to the thermostat or controller branchline output. Ratio relays can be used to control two or three pneumatic valves or damper actuators in sequence from a single thermostat. The ratio relay has a fixed input pressure range of either 20 or 35 kPa for a 70 kPa output range and an adjustable start point. For example, in a ratio relay with a 35 kPa range set for a 50 kPa start, as the input pressure varies from 48 to 83 kPa (start point plus range), the output pressure will vary from 20 to 90 kPa.

In Figure 46, three 20 kPa span ratio relays are set for 20 to 40, 40 to 60, and 60 to 80 kPa inputs, respectively. The thermostat signal through the relays proportions in sequence the three valves or actuators that have identical 20 to 90 kPa springs.

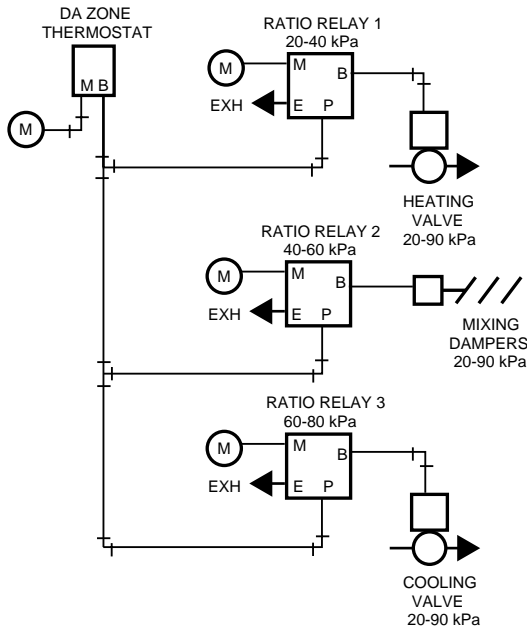

C4222

Fig. 46. Ratio Relays in Sequencing Control Application.

PNEUMATIC POTENTIOMETER

The pneumatic potentiometer is a three-port, adjustable linear restrictor used in control systems to sum two input signal values, average two input pressures, or as an adjustable flow restriction. The potentiometer is a linear, restricted air passage between two input ports. The pressure at the adjustable output port is a value based on the inputs at the two end connections and the location of the wiper between them.

Figure 47 shows a pneumatic potentiometer providing an average of two input signals. The wiper is set at mid-scale for averaging or off-center for a weighted average. It can be used this way to average two air velocity transmitter signals from ducts with different areas by positioning the wiper according to the ratio of the duct areas. This outputs a signal proportional to the airflow.

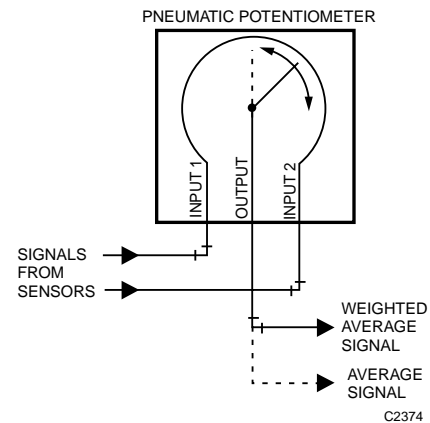

C2374

Fig. 47. Pneumatic Potentiometer as Averaging Relay.

Figure 48 shows a pneumatic potentiometer as an adjustable airflow restrictor.

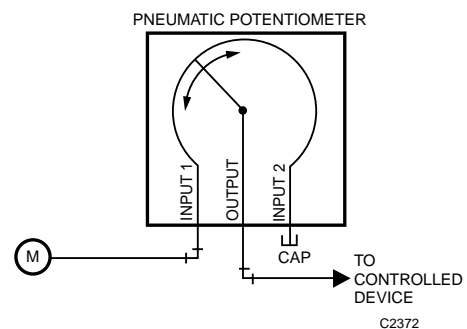

C2372

Fig. 48. Pneumatic Potentiometer as Adjustable Airflow Restrictor.

HESITATION RELAY

The hesitation relay is used with a pneumatic actuator in unit ventilator applications. The output pressure goes to minimum whenever the input pressure is below the minimum setting. Figure 49 shows a graph of the output of a hesitation relay as controlled by the relay knob settings (piloted from the thermostat).

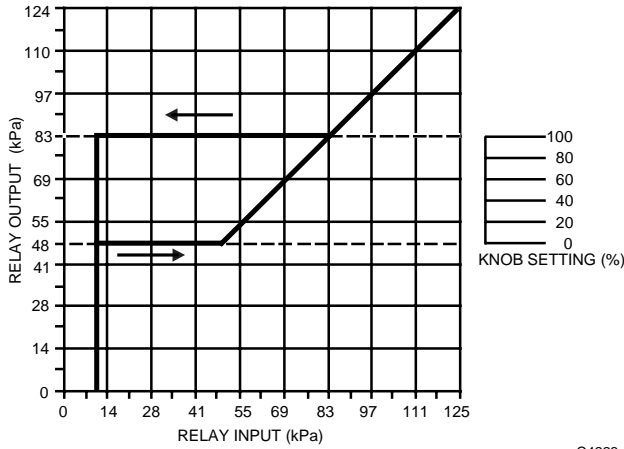

Fig. 49. Hesitation Relay Output Pressure as a Function of Knob Setting.

The hesitation relay has an internal restrictor. Figure 50 shows a typical application of a hesitation relay and a pneumatic damper actuator. When the thermostat branchline pressure reaches 10 kPa, the relay output goes to its preset minimum pressure. When the branchline pressure of the thermostat reaches the setting of the hesitation relay, the thermostat controls the damper actuator. When the thermostat branchline pressure drops below the hesitation relay setting, the relay holds the damper actuator at the minimum position until the thermostat branchline pressure drops below 10 kPa. At that point, the hesitation relay output falls to zero.

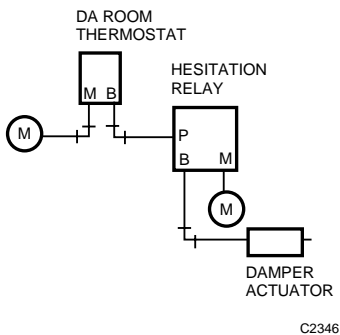

Fig. 50. Typical Hesitation Relay Application.

ELECTRICAL INTERLOCKING RELAYS

Electrical interlocking relays bridge electric and pneumatic circuits. The electric-pneumatic relay uses electric power to actuate an air valve in an associated pneumatic circuit. The pneumatic-electric relay uses control air pressure to make or break an associated electrical circuit.

ELECTRIC-PNEUMATIC RELAY

The electric-pneumatic (E/P) relay is a two-position, three-way air valve. Depending on the piping connections to the ports, the relay performs the same functions as a simple diverting relay. A common application for the E/P relay is to exhaust and close an outdoor air damper in a fan system when the fan motor is turned off, as shown in Figure 51.

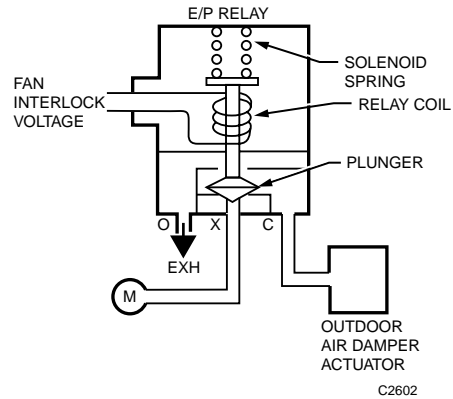

Fig. 51. E/P Relay Application.

When the relay coil is de-energized, the solenoid spring seats the plunger. The normally disconnected port (X) is blocked and the normally connected port (O) connects to the common port (C). The connection exhausts the damper actuator which closes the damper. When the relay coil is energized, the plunger lifts against the tension of the spring and blocks the normally connected port (O). Main air at the normally disconnected port (X) connects to the common port (C) and opens the damper.

PNEUMATIC-ELECTRIC RELAY

Figure 52 shows a simplified pneumatic-electric (P/E) relay with a spdt switch. The P/E relay makes the normally closed contact on a fall in pilot pressure below the setpoint, and makes the normally open contact on a rise above a value equal to the setpoint plus the differential. For example, with a setpoint adjustment of 21 kPa and a differential of 14 kPa, the pump is energized at pilot pressures below 20 kPa and turns off at pilot pressures above 35 kPa.

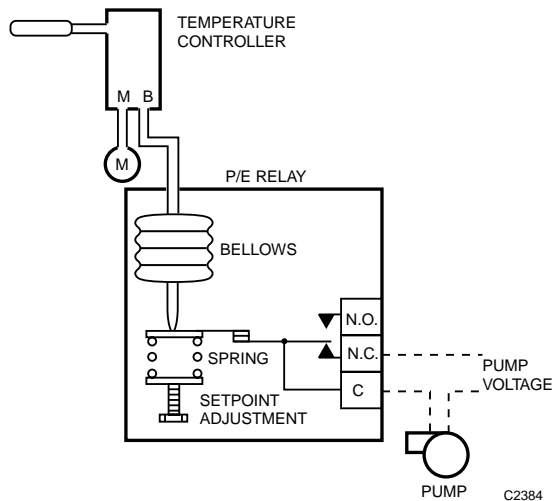

Fig. 52. P/E Relay Application.

ELECTRONIC-PNEUMATIC TRANSDUCER

The electronic-pneumatic transducer is a proportional relay that varies the branch air pressure linearly 20 to 100 kPa in response to changes in an electrical input of 2 to 10 volts or 4 to 20 mA. Electronic-pneumatic transducers are used as the interface between electronic, digital, or computer-based control systems and pneumatic output devices (e.g., actuators).

Figure 53 shows discharge air temperature control of a heating coil using digital control for sensing and control. The output of the transducer positions the valve on a heating coil.

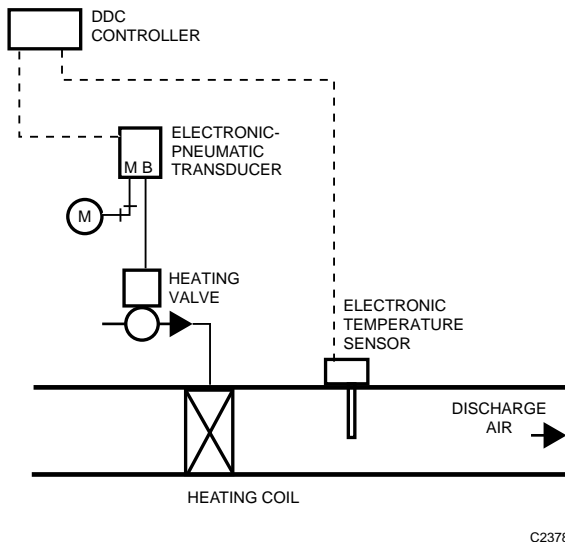

Fig. 53. Typical Electronic-Pneumatic Transducer Application.

A resistance-type temperature sensor in the discharge air duct is the input to the controller, which provides all of the system adjustments and logic requirements for control. The controller output of 2 to 10 volts dc is input to the electronic-pneumatic transducer, which converts the signal to a 20 to 100 kPa output to position the heating valve.

PNEUMATIC SWITCH

The pneumatic switch is available in two- or three-position models (Fig. 54). Rotating the switch knob causes the ports to align in one of two ways in a two-position switch, and in one of three ways in a three-position switch. The two-position switch is used for circuit interchange. The three-position switch sequentially switches the common port (Port 2) to the other ports and blocks the disconnected ports.

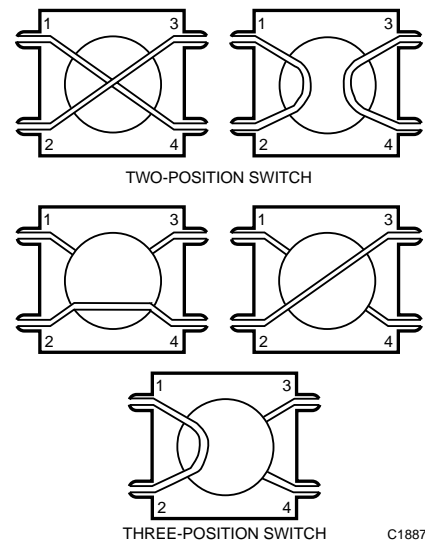

Fig. 54. Pneumatic Switches.

Figure 55 shows a typical application for sequential switching. In the OPEN position, the valve actuator exhausts through Port 4 and the valve opens. In the AUTO position, the actuator connects to the thermostat and the valve is in the automatic mode. In the CLOSED position, the actuator connects to main air and the valve closes.

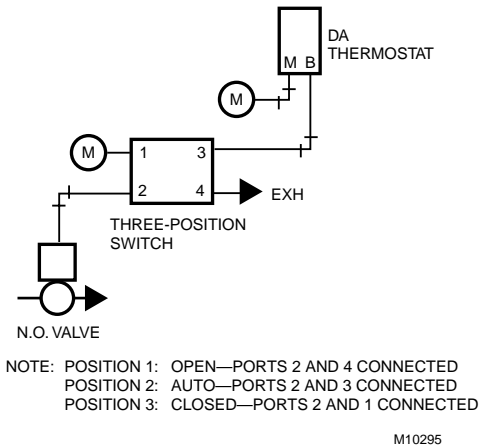

Fig. 55. Typical OPEN/AUTO/CLOSED Application.

MANUAL POSITIONING SWITCH

A manual positioning switch is used to position a remote valve or damper or change the setpoint of a controller. The switch takes input air from a controller and passes a preset, constant, minimum air pressure to the branch regardless of the controller output (e.g., to provide an adjustable minimum position of an outdoor air damper). Branchline pressure from the controller to other devices connected to the controller is not affected.

PNEUMATIC CONTROL COMBINATIONS

GENERAL

A complete control system requires combinations of several controls. Figure 57 shows a basic control combination of a thermostat and one or more control valves. A normally open control valve assembly is selected when the valve must open if the air supply fails. A normally open control valve requires a direct-acting thermostat in the heating application shown in Figure 57. Cooling applications may use normally closed valves and a direct-acting thermostat. The thermostat in Figure 57 has a 2.5 kelvins throttling range (output varies from 20 to 90 kPa of the 2.5 kelvins range) and the valves have an 55 to 85 kPa spring range, then the valve will modulate from open to closed on a 1 kelvin rise in temperature at the thermostat.

$$\frac{30 \text{ kPa}}{70 \text{ kPa}} \times 2.5^\circ\text{K} = 1^\circ\text{K}$$

Figure 56 shows the switch functioning as a minimum positioning switch. The damper will not close beyond the minimum setting of the positioning switch. As the controller signal increases above the switch setting, the switch positions the damper according to the controller signal.

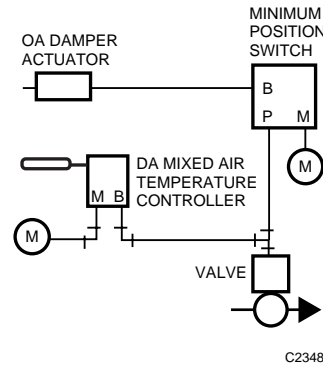

Fig. 56. Typical Three-Port Minimum Position Switch Application.

Manual switches are generally panel mounted with a dial plate or nameplate on the front of the panel which shows the switch position. Gages are sometimes furnished to indicate the main and branch pressures to the switch.

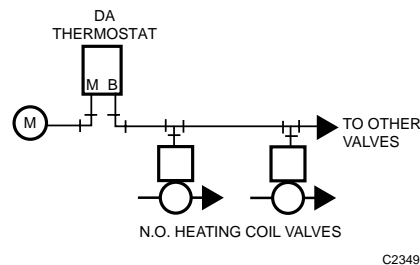

Fig. 57. Thermostat and One or More Normally Open Valves.

A normally open or a normally closed valve may be combined with a direct-acting or a reverse-acting thermostat, depending on the requirements and the conditions in the controlled space. Applications that require several valves controlled in unison (e.g., multiple hot water radiation units in a large open area) have two constraints:

- All valves that perform the same function must be of the same normal position (all normally open or all normally closed).

- The controller must be located where the condition it measures is uniformly affected by changes in position of the multiple valves. If not, the application requires more than one controller.

A direct- or reverse-acting signal to a three-way mixing or diverting valve must be selected carefully. Figure 58 shows that the piping configuration determines the signal required.

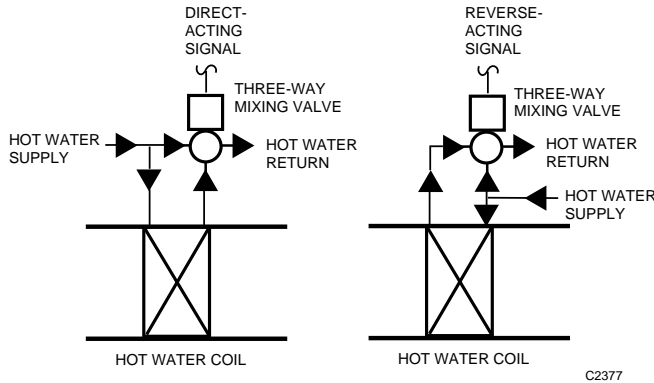

Fig. 58. Three-Way Mixing Valve Piping with Direct Actuators.

SEQUENCE CONTROL

In pneumatic control systems, one controller can operate several dampers or valves or several groups of dampers or valves. For example, year-round air conditioning systems sometimes require heating in the morning and evening and cooling in the afternoon. Figure 59 shows a system in which a single controller controls a normally open heating valve and normally closed cooling valve. The cooling valve is set for an 55 to 90 kPa range and the heating valve, for a 13 to 48 kPa range. The controller operates the two valves in sequence to hold the temperature at the desired level continually.

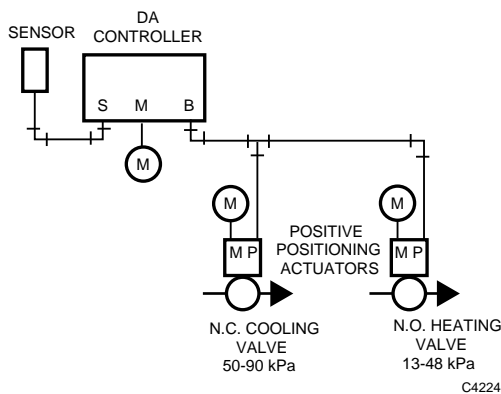

Fig. 59. Pneumatic Sequencing of Two Valves with Positive Positioning Actuators.

When the temperature is so low that the controller calls for full heat, the branchline pressure is less than 20 kPa. The normally open heating valve is open and the normally closed

cooling valve is closed. As the temperature rises, the branchline pressure increases and the heating valve starts to close. At 48 kPa branchline pressure, the heating valve is fully closed. If the temperature continues to rise, the branchline pressure increases until the cooling valve starts to open at 55 kPa. The temperature must rise enough to increase the branchline pressure to 90 kPa before the cooling valve will be full open. On a drop in temperature, the sequence is reversed.

Valves with positive positioners ensure tight close-off of the heating valve at 48 kPa branchline pressure, and delay opening of the cooling valve until 55 kPa branchline pressure is reached. Positive positioners prevent overlapping caused by a variation in medium pressure, a binding valve or damper, or a variation in spring tension when using spring ranges for sequencing.

A greater deadband can be set on the positioners to provide a larger span when no energy is consumed. For example, if the positioners are set for 13 to 48 kPa on heating and 90 to 124 kPa on cooling, no energy is used when the controller branchline pressure is between 48 and 90 kPa. The positioners can also be set to overlap (e.g., 30 to 60 and 48 to 80 kPa) if required.

Valve and damper actuators without positioners have various spring ranges. To perform the sequencing application in Figure 59 without positioners, select a heating valve actuator that has a 13 to 48 kPa spring range and a cooling valve actuator that has an 55 to 90 kPa spring range. Although this method lessens precise positioning, it is usually acceptable in systems with lower pressure differentials across the valve or damper and on smaller valves and dampers .

LIMIT CONTROL

Figure 60 shows a sensor-controller combination for space temperature control with discharge low limit. The discharge low limit controller on a heating system prevents the discharge air temperature from dropping below a desired minimum.

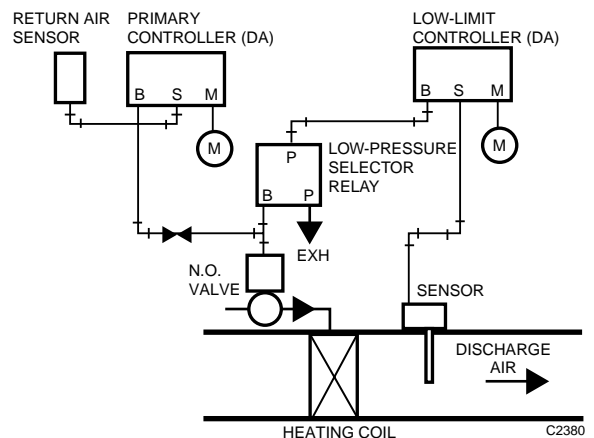

Fig. 60. Low-Limit Control (Heating Application).

Low-limit control applications typically use a direct-acting primary controller and a normally open control valve. The direct-acting, low-limit controller can lower the branchline pressure regardless of the demands of the room controller, thus opening the valve to prevent the discharge air temperature from dropping below the limit controller setpoint. Whenever the low-limit discharge air sensor takes control, however, the return air sensor will not control. When the low-limit discharge air sensor takes control, the space temperature increases and the return air sensor will be unable to control it.

A similar combination can be used for a high-limit heating control system without the selector relay in Figure 61. The limit controller output is piped into the exhaust port of the primary controller, which allows the limit controller to limit the bleed-down of the primary controller branch line.

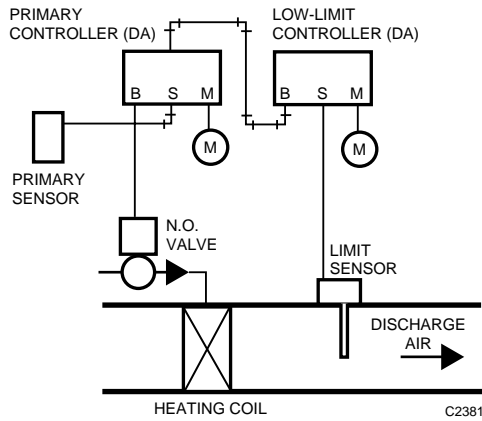

Fig. 61. High-Limit Control (Heating Application).

Bleed-type, low-limit controllers can be used with pilot-bleed thermostats (Fig. 62). A restrictor installed between the thermostat and the low limit controller, allows the low limit controller to bleed the branch line and open the valve. The restrictor allows the limit controller to bleed air from the valve actuator faster than the thermostat can supply it, thus overriding the thermostat.

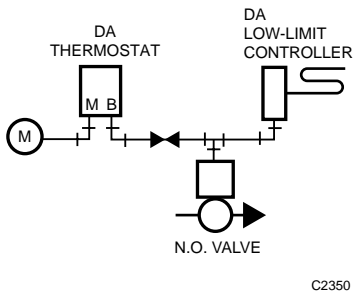

Fig. 62. Bleed-Type, Low-Limit Control System.

MANUAL SWITCH CONTROL

Common applications for a diverting switch include on/off/automatic control for a heating or a cooling valve, open/closed control for a damper, and changeover control for a two-pressure air supply system. Typical applications for a proportional switch include manual positioning, remote control point adjustment, and minimum damper positioning.

Figure 63 shows an application for the two-position manual switch. In Position 1, the switch places the thermostat in control of Valve 1 and opens Valve 2 by bleeding Valve 2 to zero through Port 1. When turned to Position 2, the switch places the thermostat in control of Valve 2 and Valve 1 opens.

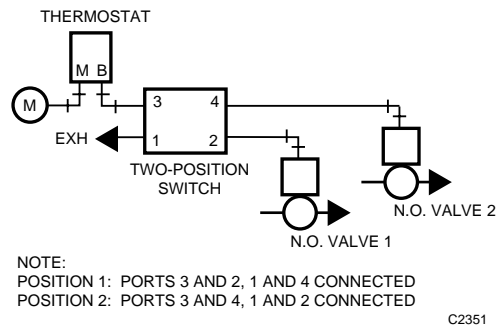

Fig. 63. Application for Two-Position Manual Switch.

Figure 64 shows an application of the three-position switch and a proportioning manual positioning switch.

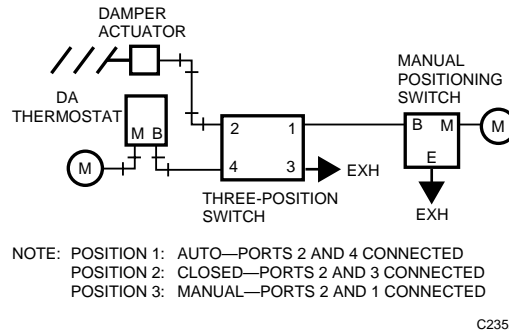
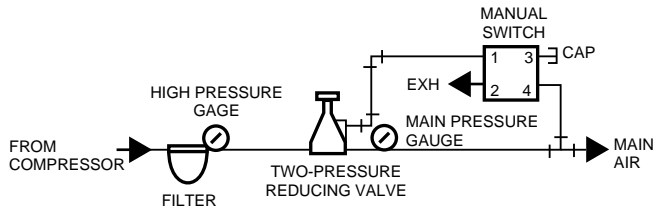

Fig. 64. Application for Three-Position Switch and Manual Positioning Switch.

In Position 1, the three-position switch places the thermostat in control of the damper. Position 2 closes the damper by bleeding air pressure to zero through Port 3. Position 3 allows the manual positioning switch to control the damper.

CHANGEOVER CONTROL FOR TWO-PRESSURE SUPPLY SYSTEM

Figure 65 shows a manual switch used for changeover from 90 to 124 kPa in the mains. Either heating/cooling or day/night control systems can use this arrangement. In Position 1, the switch supplies main pressure to the pilot chamber in the PRV. The PRV then provides 124 kPa (night or heating) main air pressure to the control system.



C2375

Fig. 65. Two-Pressure Main Supply System with Manual Changeover.

In Position 2, the manual switch exhausts the pilot chamber in the PRV. The PRV then provides 90 kPa (day or cooling) to the system.

Figure 66 shows a two-pressure system with automatic changeover commonly used in day/night control. A switch in a seven-day time clock and an E/P relay provide the changeover. When the E/P relay energizes (day cycle), the pilot chamber in the PRV exhausts and controls at 90 kPa. When the electric-pneumatic relay de-energizes, the pilot chamber receives full main pressure and the PRV provides 124 kPa air.

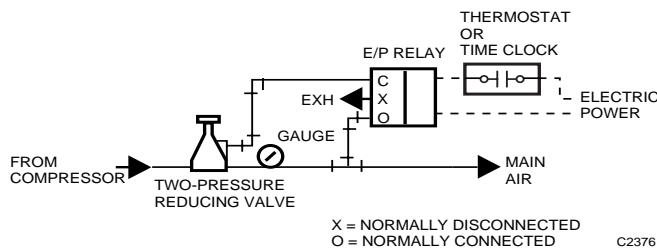

C2376

Fig. 66. Two-Pressure Main Supply System with Automatic Changeover.

COMPENSATED CONTROL SYSTEM

In a typical compensated control system (Fig. 67), a dual-input controller increases or decreases the temperature of the supply water as the outdoor temperature varies. In this application, the dual-input controller resets the water temperature setpoint as a function of the outdoor temperature

according to a preset schedule. The system then provides the scheduled water temperature to the convectors, fan-coil units, or other heat exchangers in the system.

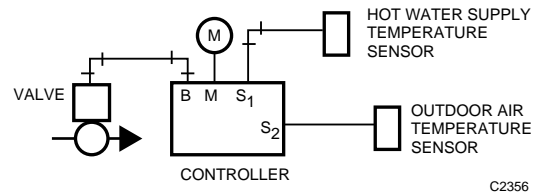

C2356

Fig. 67. Compensated Supply Water System Using Dual-Input Controller.

ELECTRIC-PNEUMATIC RELAY CONTROL

Figure 68 shows one use of an E/P relay in a pneumatic control circuit. The E/P relay connects to a fan circuit and energizes when the fan is running and de-energizes when the fan turns off, allowing the outdoor air damper to close automatically when the fan turns off. The relay closes off the controller branch line, exhausts the branch line going to the damper actuator, and allows the damper to go to its normal (closed) position. Figure 69 shows an E/P relay application that shuts down an entire control system.

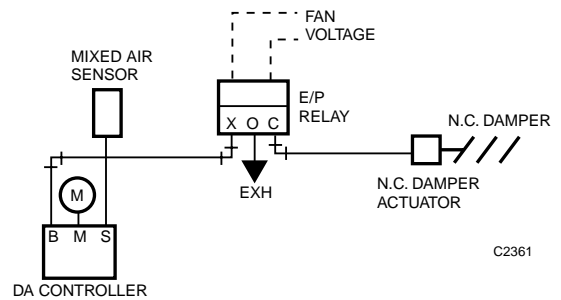

C2361

Fig. 68. Simple E/P Relay Combination.

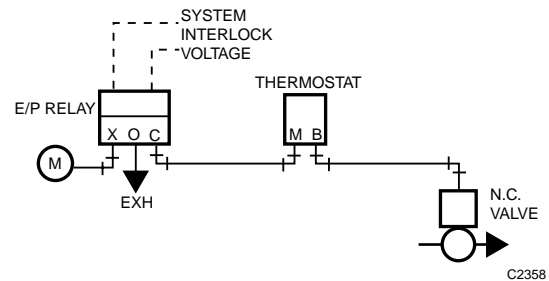

C2358

Fig. 69. E/P Relay Combination for System Shutdown.

PNEUMATIC-ELECTRIC RELAY CONTROL

A P/E relay provides the interlock when a pneumatic controller actuates electric equipment. The relays can be set for any desired pressure. Figure 70 shows two P/E relays sequenced to start two fans, one at a time, as the fans are needed.

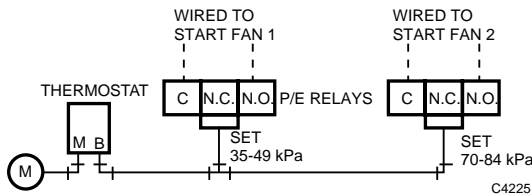

Fig. 70. P/E Relays Controlling Fans in Sequence.

On a rise in temperature, Relay 1 puts Fan 1 in operation as the thermostat branchline pressure reaches 49 kPa. Relay 2 starts Fan 2 when the controller branchline pressure reaches 84 kPa. On a decrease in branchline pressure, Relay 2 stops Fan 2 at 70 kPa branchline pressure, and Relay 1 stops Fan 1 at 35 kPa branchline pressure.

Figure 71 shows two spdt P/E relays starting and stopping a two-speed fan to control condenser water temperature.

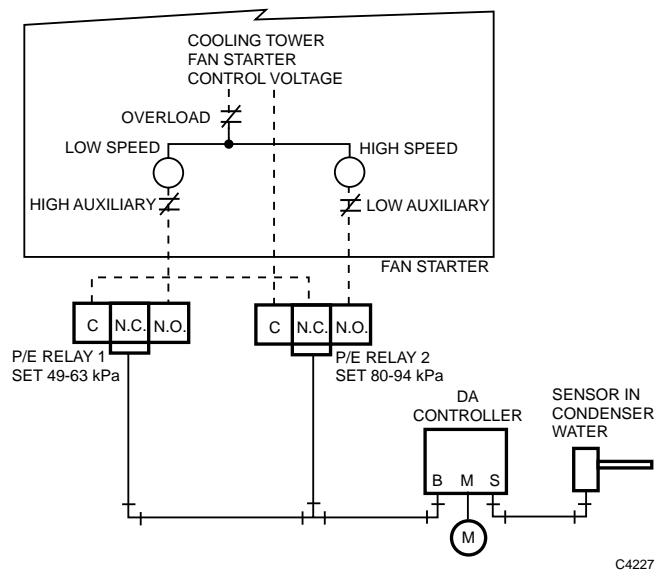

Fig. 71. Two-Speed Fan Operated by P/E Relays.

Voltage is applied to the common contact of Relay 1 from the normally closed contact of Relay 2. When the controller branchline pressure rises to 63 kPa, the cooling tower fan is

started on low speed by Relay 1 which makes common to normally open. As a further rise in temperature increases the branchline pressure to 94 kPa, Relay 2 breaks the normally closed circuit and makes the normally open circuit, removing voltage from Relay 1, shutting down the low speed, and energizing the high speed. On a decrease in temperature, the sequence reverses and the changes occur at 80 and 49 kPa respectively.

PNEUMATIC RECYCLING CONTROL

E/P and P/E relays can combine to perform a variety of logic functions. On a circuit with multiple electrically operated devices, recycling control can start the devices in sequence to prevent the circuit from being overloaded. If power fails, recycling the system from its starting point prevents the circuit overload that could occur if all electric equipment restarts simultaneously when power resumes.

Figure 72 shows a pneumatic-electric system that recycles equipment when power fails.

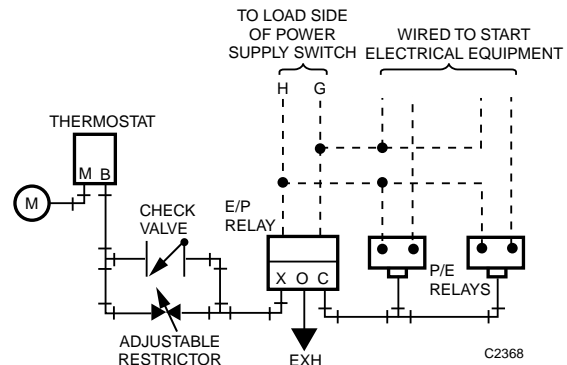

Fig. 72. Recycling System for Power Failure.

When power is applied, the E/P relay operates to close the exhaust and connect the thermostat through an adjustable restrictor to the P/E relays. The electrical equipment starts in sequence determined by the P/E relay settings, the adjustable restrictor, and the branchline pressure from the thermostat. The adjustable restrictor provides a gradual buildup of branchline pressure to the P/E relays for an adjustable delay between startups. On power failure, the E/P relay cuts off the thermostat branch line to the two P/E relays and bleeds them off through its exhaust port, shutting down the electrical equipment. The check valve allows the thermostat to shed the controlled loads as rapidly as needed (without the delay imposed by the restrictor).

PNEUMATIC CENTRALIZATION

Building environmental systems may be pneumatically automated to any degree desired. Figure 73 provides an example of the front of a pneumatic automation panel. This panel contains pneumatic controls and may be local to the controlled HVAC system, or it may be located centrally in a more convenient location.

In this example, the on-off toggle switch starts and stops the fan. The toggle switch may be electric, or pneumatic with a Pneumatic-Electric (P/E) relay.

Two pneumatic “target” gauges are shown for the outside air damper and the supply fan. The ON/OFF Supply Fan Gauge is fed from a fan proof-of-flow relay, and the OPEN/CLOSED Damper Gauge is fed from the damper control line.

The Discharge Air Temperature Indicator is fed from the pneumatic discharge air temperature sensor and the Three-Way Valve Gauge is fed from the valve control line.

When pneumatic automation panels are located local to the HVAC system, they are usually connected with 6 mm plastic tubing. When there are many lines at extended lengths, smaller diameter plastic tubing may be preferable to save space and maintain responsiveness. When the panel devices are remote, the air supply should be sourced remotely to avoid pressure losses due to long flow lines. The switching air may be from the automation panel or it may be fed via a remote restrictor and piped in an exhaust configuration.

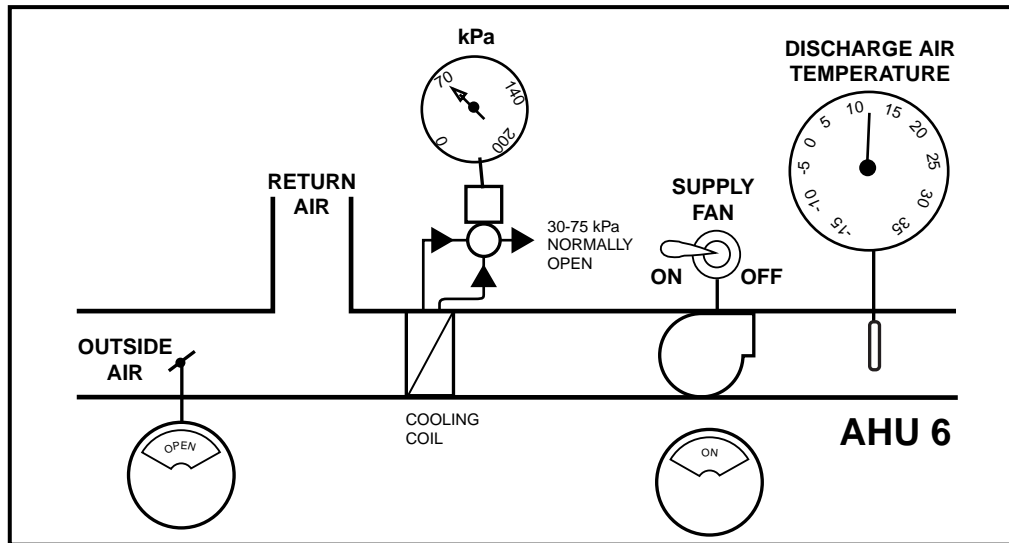

M15142

Fig. 73. Pneumatic Centralization

PNEUMATIC CONTROL SYSTEM EXAMPLE

The following is an example of a typical air handling system (Fig. 74) with a pneumatic control system. The control system is presented in the following seven control sequences (Fig. 75 through 79):

- Start-Stop Control Sequence.
- Supply Fan Control Sequence.
- Return Fan Control Sequence.
- Warm-Up/Heating Coil Control Sequence.
- Mixing Damper Control Sequence.
- Discharge Air Temperature Control Sequence.
- Off/Failure Mode Control Sequence.

Controls are based upon the following system information and control requirements:

System Information:

- VAV air handling system.
- Return fan.
- 16.5 m³/s.
- 1.9 m³/s outside air.
- 1.4 m³/s exhaust air.
- Variable speed drives.
- Hot water coil for morning warm-up and to prevent discharge air from getting too cold in winter .
- Chilled water coil.
- Fan powered perimeter VAV boxes with hot water reheat.
- Interior VAV boxes.
- Water-side economizer.
- 8:00 A.M. to 5:00 P.M. normal occupancy.
- Some after-hour operation.

Control Requirements:

- Maintain design outside air airflow during all levels of supply fan loading during occupied periods.
- Use normally open two-way valves so system can heat or cool upon compressed air failure by manually running pumps and adjusting water temperatures.
- Provide exhaust/ventilation during after-hour occupied periods.
- Return fan sized for 16.5 m³/s.

START-STOP CONTROL SEQUENCE

Fans 1M through 3M (Fig. 75) operate automatically subject to starter-mounted Hand-Off-Automatic Switches.

The Supply Fan 1M is started and controls are energized by Electric-Pneumatic Relay 2EP at 0645 by one of the following:

- An Early Start Time Clock 1TC
- A drop in perimeter space temperature to 18°C at Night Thermostat TN
- An after-hour occupant setting the Spring-Wound Interval Timer for 0 to 60 minutes.

The Supply Fan 1M operation is subject to manually reset safety devices including Supply and Return Air Smoke Detectors; a heating coil, leaving air, Low Temperature Thermostat; and a supply fan discharge, duct High Static Pressure Cut-Out.

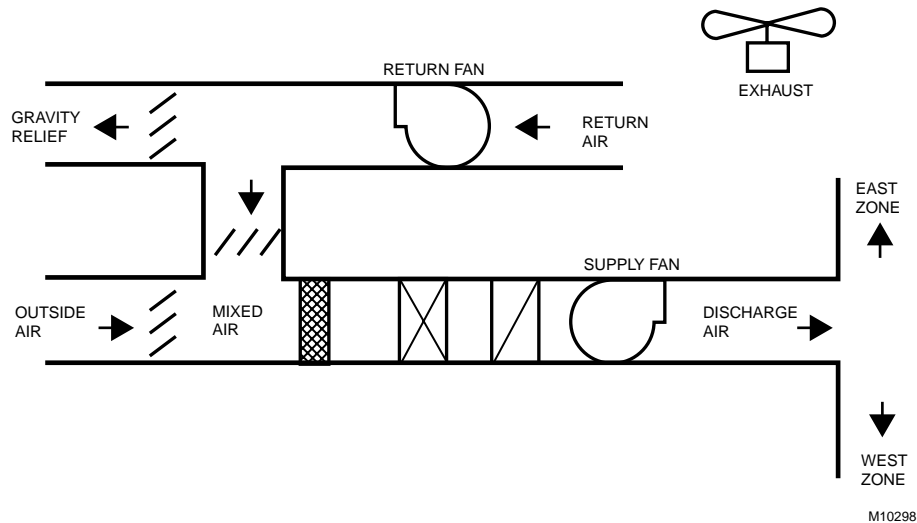

Fig. 74. Typical Air Handling System.

Any time the Supply Fan 1M runs, the Return Fan 2M runs.

Interval Timer or by the Occupancy Schedule Time Clock 2TC set for 0750.

Any time the Return Fan 2M runs, the Exhaust Fan 3M and the ventilation controls are energized by the After-Hours

Both Clocks 1TC and 2TC are set to shut the system down at 1700.

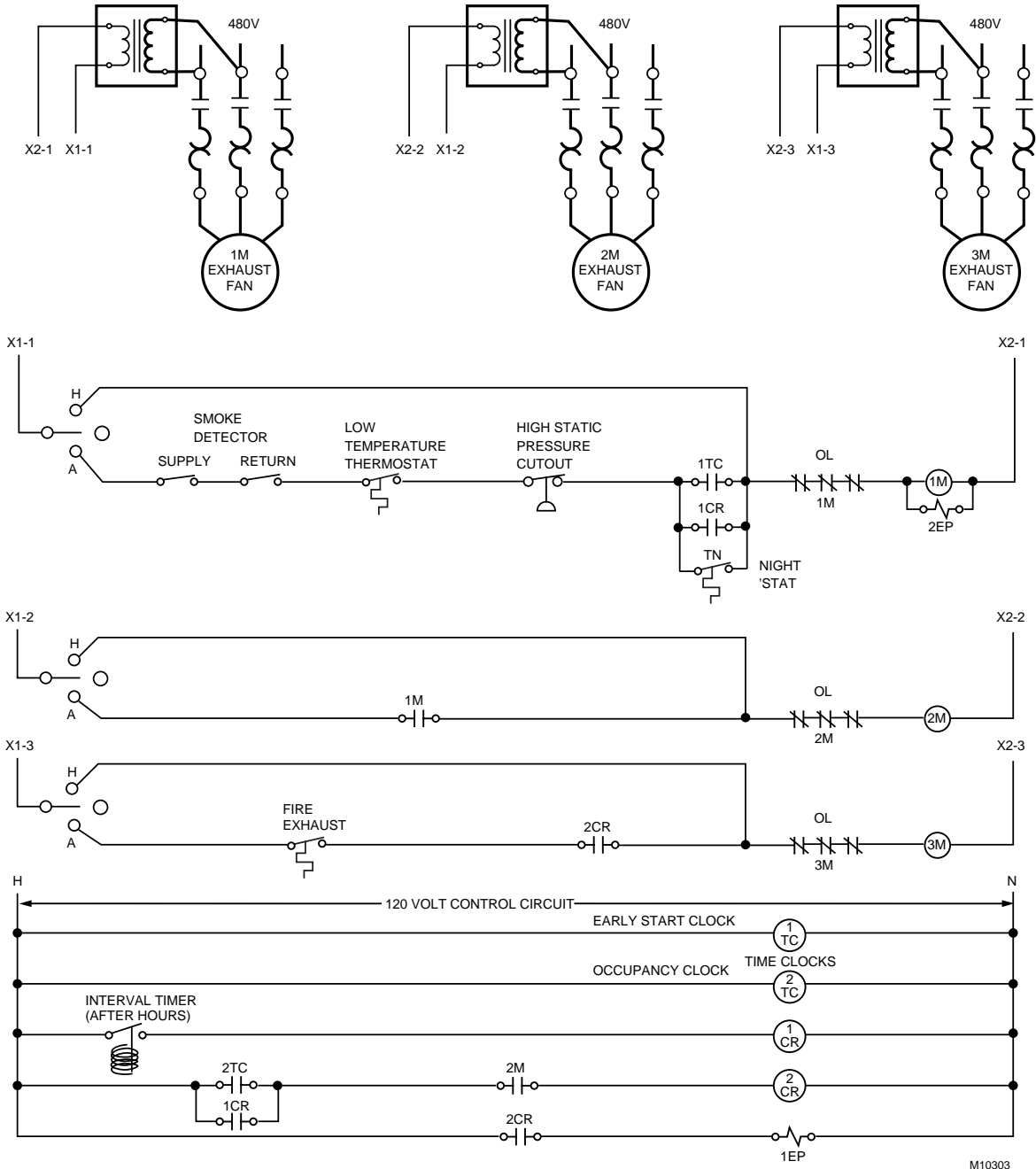

Fig. 75. Start-Stop Control.

SUPPLY FAN CONTROL SEQUENCE

Any time the Supply Fan (Fig. 76) runs, the pressure controller with the greatest demand, Static Pressure Controller PC₁ or PC₂, operates the Electronic-Pressure Transducer PT. The controller used is determined by High Pressure Selector Relay HSR. Transducer PT controls the Supply Fan Variable Speed Drive (VSD) to maintain duct static pressure. The pick-up probes for Static Pressure Controllers PC₁ and PC₂ are located at the end of the east and west zone ducts.

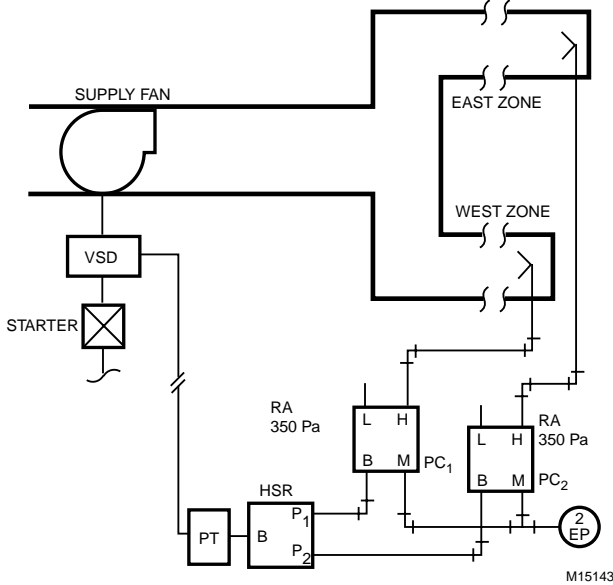

Fig. 76. Supply Fan Load Control.

RETURN FAN CONTROL SEQUENCE

Static Pressure Controller PC (Fig. 77) controls the return fan variable speed drive to maintain space static pressure. The pick-up probe is located in the space

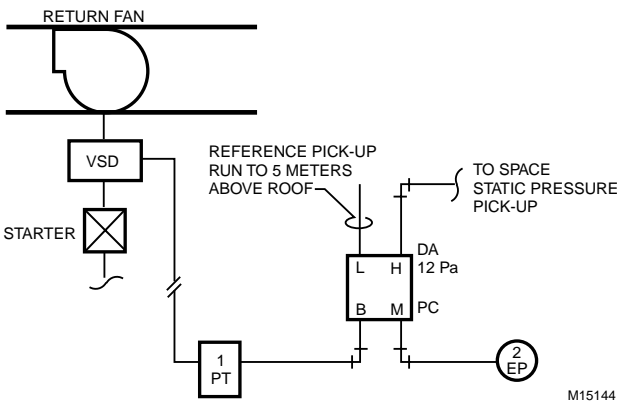

Fig. 77. Return Fan Load Control.

- NOTE:
1. Because of varying exhaust between occupied and warm-up modes, space static pressure control of the return fan is selected. Return fan tracking from supply fan airflow is acceptable but is complex if varying exhaust is worked into the control scheme.
 2. Exercise care in selecting location of the inside pickup and in selection of the pressure controller. Location of the reference pickup above the roof is recommended by ASHRAE.
 3. To prevent unnecessary hunting by the return fan at start-up, the supply fan control signal should be slow loading such that the supply fan goes from zero or a minimum to maximum load over three minutes. Shut down should not be restricted.

WARM-UP/HEATING COIL CONTROL SEQUENCE

Any time the Supply Fan (Fig. 78) runs and the return air temperature is below 20.5°C, Temperature Controller TC-1 trips Snap-Acting Relay SA-1 to position Switching Relays SR-1 and SR-2 to initialize warm-up control. Relay SA-1 also positions Switching Relay SR-4 to disable cooling controls. Switching Relay SR-2 opens all interior VAV box dampers and starts the hot water pump. Relay SR-1 switches the hot water valve from normal control to warm-up control via Controller TC-2 and modulates the hot water valve to maintain a discharge air temperature setpoint of 32°C.

- NOTE:
- Fan powered perimeter VAV boxes are cool in this mode and operate with the fans on and at the minimum airflow (warm air) setpoints. Reheat valves at each box operate as needed. This allows the warm-up cycle to operate the air handling unit (AHU) fans at a reduced and low cost power range.

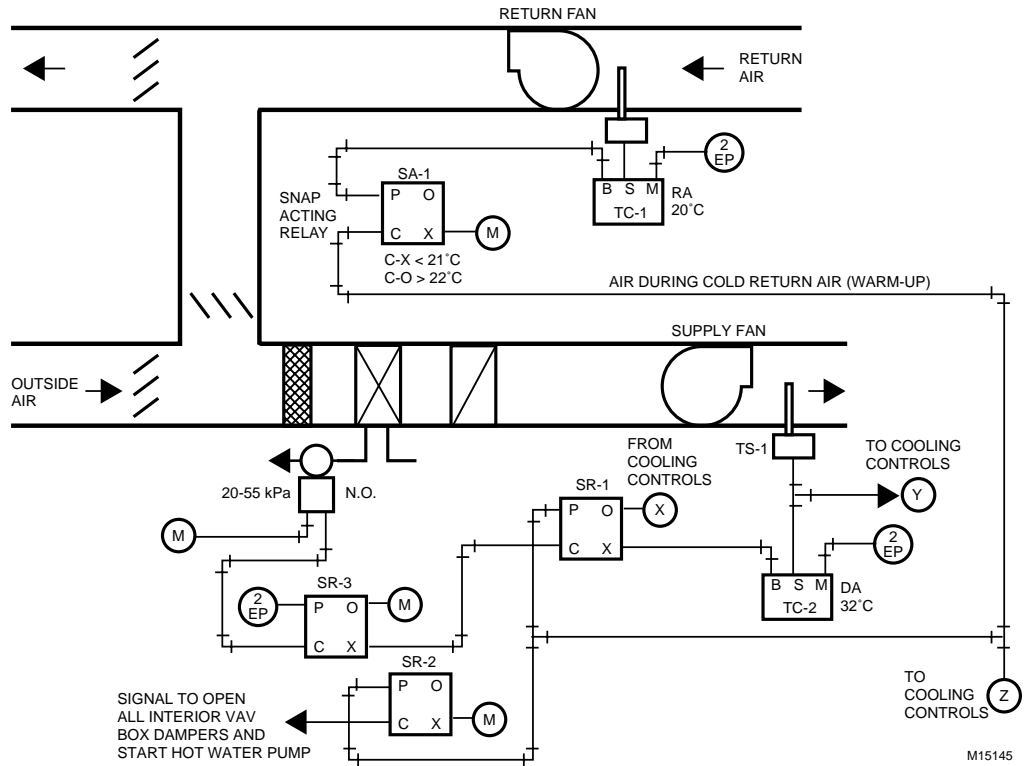

Fig. 78. Heating Coil Control.

MIXING DAMPER CONTROL SEQUENCE

Any time the AHU (Fig. 79) runs in the occupied mode with Electric-Pneumatic Relay 1EP energized, Outside Air airflow Controller P-F modulates the outside air damper toward open and the return air damper toward closed (or vice versa) in unison to maintain design outside air at 1.9 m³/s.

NOTE: These dampers can control in sequence also, but unison control positions the damper blades better for mixing which is helpful during freezing periods. If the outside air is provided from an outside air shaft with an outside air fan, an outside air filter is helpful to keep the flow sensing element/pick-up clean and effective. Electric-Pneumatic Relay 1EP starts the outside air system.

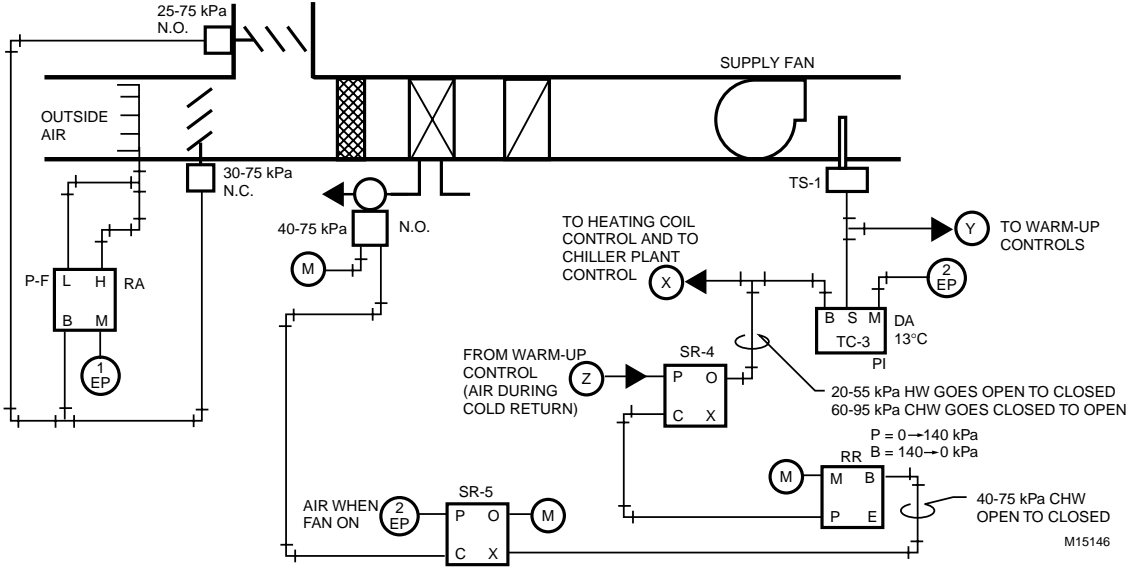

Fig. 79. Mixing Damper and Discharge Air Temperature Control.

DISCHARGE AIR TEMPERATURE CONTROL SEQUENCE

Any time the AHU (Fig. 79) operates in the non-warm-up mode, Switching Relay SR-4 operates to allow the normal Discharge Air Temperature Controller TC-3 to modulate the hot water valve closed (through Switching Relay SR-1, Fig. 77) and the chilled water valve open in sequence, on a rising cooling load, to maintain the Temperature Controller TC-3 setpoint. Controller TC-3 is a PI (proportional plus integral) controller.

NOTE: In this constant 1.9 m³/s outside air system, if the return air is 22°C and the outside air is -25°C, the mixed air temperature will drop below 13°C if the AHU airflow drops below 52 percent of the design airflow.

OFF/FAILURE MODE CONTROL SEQUENCE

If compressed air fails, both control valves open, the outside air damper closes, and the return air damper opens.

When the fan is off, Switching Relay SR-3 (Fig. 78) positions to close the hot water valve, Switching Relay SR-5 (Fig. 79) positions to close the chilled water valve, the outside air damper closes, and the return air damper opens.

Electric Control Fundamentals

ENGINEERING MANUAL OF AUTOMATIC CONTROL

		CONTENTS
Introduction	97
Definitions	97
How Electric Control Circuits are Classified	99
Series 40 Control Circuits	100
Application	100
Equipment	100
Controllers	100
Relays	100
Actuators	100
Operation	101
Control Combinations	101
Unit Heater Control	101
High-Limit Control	101
Low-Limit Control	102
Series 80 Control Circuits	102
Application	102
Equipment	102
Controllers	102
Relays and Actuators	102
Operation	102
Control Combinations	103
High-Limit Control	103
Low-Limit Control	103
Series 60 Two-Position Control Circuits	103
Application	103
Equipment	103
Controllers	103
Actuators	103
Operation	104
Control Combinations	105
Two-Position Control of Steam Valve	105
Summer/Winter Changeover Control of a Three-Way Diverting Valve	105
Open-Closed Control of Damper	105
Series 60 Floating Control Circuits	106
Application	106
Equipment	106
Controllers	106
Actuators	106
Operation	106
Control Combinations	106

Series 90 Control Circuits	107
Application	107
Equipment	107
Controllers	107
Actuators	107
Operation	108
General	108
Bridge Circuit Theory	108
Basic Bridge Circuit	108
Bridge Circuit in Balanced Condition	108
Bridge Circuit on Increase in Controlled Variable	108
Bridge Circuit on Decrease in Controlled Variable	109
Bridge Circuit with Limit Controls	109
Bridge Circuit with Low-Limit Control	110
Bridge Circuit with High-Limit Control	110
Control Combinations	111
Low-Limit Control	111
High-Limit Control	111
Two-Position Limit Control	112
Manual and Automatic Switching	112
Closing the Actuator with a Manual Switch	112
Transferring Actuator Control from	
One Thermostat to Another	112
Reversing for Heating and Cooling Control	112
Transferring Controller from	
One Actuator to Another	113
Unison Control	113
Manual Minimum Positioning of Outdoor Air Damper	113
Step Controllers	114
 Motor Control Circuits	 114
Application	114
Equipment	114
Starters	114
Contactors and Relays	114
Operation	115
Momentary Start-Stop Circuit	115
Hand-Off-Auto Start-Stop Circuit	115
Momentary Fast-Slow-Off Start-Stop Circuit	116
Control Combinations	117

INTRODUCTION

This section provides information on electric control circuits used in heating, ventilating, and air conditioning systems. Electric energy is commonly used to transmit the measurement of a change in a controlled condition from a controller to other parts of a system and to translate the change into work at the final control element. For these purposes, electricity offers the following advantages:

- It is available wherever power lines can be run.
- The wiring is usually simple and easy to install.
- The signals received from sensing elements can be used to produce one or a combination of electro-mechanical outputs. For example, several actuators can be controlled from one controller.
- Single controller-actuator combinations are possible without the need for a main-air source as in pneumatic control.

Electric controls consist of valve/damper actuators, temperature/pressure/humidity controllers, relays, motor starters and contactors. They are powered by low or line voltage, depending on the circuit requirements. Controllers can be wired to perform either primary or limit functions (high or low limit). Electric actuators can be two position or proportioning and either spring return or nonspring return.

The information in this section is of a general nature and intended to explain electric control fundamentals. There are places where Honeywell nomenclature is used, such as R, W, B, for wiring terminals and Series 40 through 90 for classifying control circuits. These may vary with controls of a different manufacturer.

DEFINITIONS

Actuator: A device used to position control dampers and control valves. Electric actuators consist of an electric motor coupled to a gear train and output shaft. Typically, the shaft drives through 90 degrees or 160 degrees of rotation depending on the application. For example, 90-degree stroke actuators are used with dampers, and 160-degree stroke actuators are used with valves. Limit switches, in the actuator, stop the motor at either end of the stroke or current limiters sense when the motor is stalled at the end of the stroke. Actuator gear trains are generally factory lubricated for life so no additional lubrication is necessary.

Actuators may attach to the valve stem or damper shaft through a linkage or be direct coupled connecting directly to the stem or shaft.

In some actuators the motor is electrically reversible by the controller. A Solenoid brake is commonly used on spring-return actuators to hold the actuator in the control position. Some actuators have a return spring which enables the output shaft to return to the normal position on loss or interruption of power. Most two-position actuators drive electrically to the control position and rely on only the spring to return to the normal position. Spring-return actuators have approximately one-third the output torque of comparable non-spring-return actuators since the motor must drive in one direction against the return spring. A return-to-normal position on power failure

function maybe provided by an integral rechargeable battery, capacitor, or constantly wound spring so that there is no reduction in operating force.

The direction of shaft rotation on loss of power varies by model for spring-return actuators. The direction can be clockwise (cw) or counterclockwise (ccw) as viewed from the power end of the actuator. Actuator controlled valves and dampers also vary as to whether they open or close on a loss of power. This depends on the specific actuator, linkage arrangement, and valve or damper selected. Because of these factors, the terms cw/ccw or open/close as used in this literature are for understanding typical circuits only and do not apply to any particular model of actuator.

Actuators are available with various timings to drive through full stroke such as 15, 30, 60, 120, or 240 sec. In general, the timing is selected to meet the application requirements (e.g., an actuator with 240 sec timing might be used to control the inlet vanes to a fan in a floating control system).

Actuators designated as line voltage have line-voltage inputs but commonly have a low-voltage control circuit since the motor is powered by low voltage. A transformer is used to supply power to the low voltage motor coils. It can be built into the actuator housing (Fig. 1) or supplied separately.

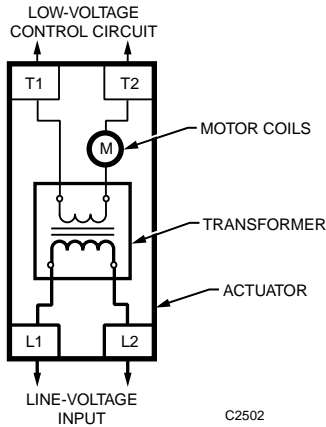

Fig. 1. Typical Actuator Wiring.

Contact arrangement: The electric switch configuration of a controller, relay, contactor, motor starter, limit switch, or other control device. Contacts which complete circuits when a relay is energized (pulled in) are called normally open (N.O.) or “in” contacts. Contacts which complete electric circuits when a relay is deenergized (dropped out) are called normally closed (N.C.) or “out” contacts. Many contact arrangements are available depending on the control device. Figure 2 illustrates three contact arrangements.

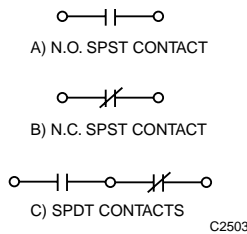

Fig. 2. Typical Contact Arrangements.

Control valve: A device used to control the flow of fluids such as steam or water.

Controller: A temperature, humidity, or pressure actuated device used to provide two-position, floating, or proportioning control of an actuator or relay. It may contain a mercury switch, snap-acting contacts, or a potentiometer. Controllers can be two-wire or three-wire devices. Two-wire controllers are spst devices. The N.O. type (Fig. 3A) generally opens the circuit on a fall in the controlled variable and closes the circuit on a rise. The N.C. type (Fig. 3B) generally closes the circuit on a fall in the controlled variable and opens the circuit on a rise. Three-wire controllers are spdt, floating, or potentiometer devices. The spdt controllers (Fig. 3C) generally close R to B contacts and open R to W contacts on a fall in the controlled variable. The opposite occurs on a rise. The controllers in Figures 3A through 3C do not have a true N.O./N.C. contact arrangement but provide a

switching action dependent on the condition of the controlled variable. Floating controllers (Fig. 3D) are spdt devices with a center-off position. Refer to SERIES 60 FLOATING CONTROL CIRCUITS for a discussion of floating control operation. Potentiometer controllers (Fig. 3E) move the wiper (R) toward B on a fall and toward W on a rise in the controlled variable. This action varies the resistance in both legs of the potentiometer and is used for proportional control.

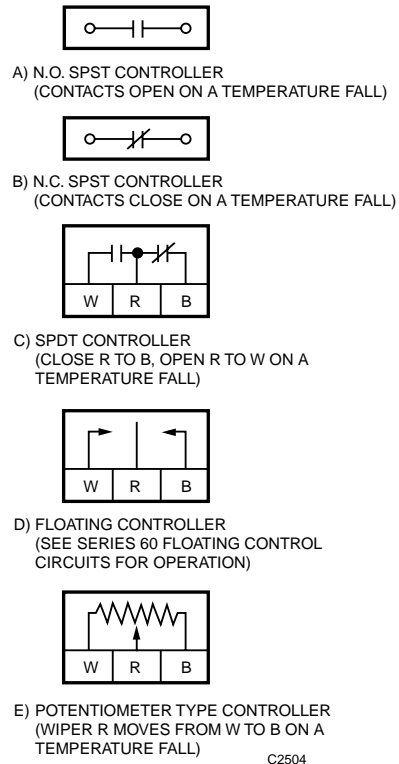

Fig. 3. Typical Controller Action.

Control Modes:

Modulating Control: When an actuator is energized, it moves the damper or valve a distance proportional to the sensed change in the controlled variable. For example, a Series 90 thermostat with a 5 kelvins throttling range moves the actuator 1/5 of the total travel for each degree change in temperature.

Two-Position Control: When an actuator is energized it moves the valve or damper to one of the extreme positions. The valve or damper position remains unchanged until conditions at the controller have moved through the entire range of the differential.

Floating Control: When an actuator is energized, it moves the damper or valve until the controller is satisfied. The actuator maintains that position until the controller senses a need to adjust the output of the valve or damper.

Damper: A device used to control the flow of air in a duct or through a wall louver.

Line voltage: A term which refers to the normal electric supply voltage. Line voltage can be used directly in some control circuits or can be connected to the primary side of a step down transformer to provide power for a low-voltage control circuit. Most line-voltage devices function at their rated voltage +10%/–15%. Line-voltage devices should be tested and listed by an appropriate approval agency.

Linkage: A device which connects an actuator to a damper or control valve. To open and close a damper, the typical linkage consists of an actuator crankarm, balljoints, pushrod, and damper crank arm. In a valve application,

the linkage connects the actuator to the valve and translates the rotary output of the actuator to the linear action of the valve stem.

Low voltage: A term which applies to wiring or other electrical devices using 30 volts or less. Low-voltage control devices usually function on 24V ac +10%/–15%.

Relay: A device consisting of a solenoid coil which operates load-carrying switching contacts when the coil is energized. Relays can have single or multiple contacts.

Transformer: A device used to change voltage from one level to another. For control circuits this is usually line voltage to low voltage. Transformers can be used only on ac power.

HOW ELECTRIC CONTROL CIRCUITS ARE CLASSIFIED

There are seven basic electric control circuits, each of which has unique characteristics. These control circuits are identified by Series Numbers 10, 20, 40, 60, 70, 80, and 90 (Table 1). Series 10 and 20 are no longer used. Series 70 is electronic control and is covered in the Electronic Control Fundamentals section.

The construction of individual control devices conforms to the requirements for the basic series for which it is intended. However, there are many applications which incorporate controls of different series in the same control circuit.

Table 1. Honeywell Electric Control Circuits.

Series	Controller	Signal Circuit	Actuator/Relay	Control Mode
40	Line voltage, spst. Makes circuit when switch is closed, breaks it when switch is open.	Two-wire, line voltage	Any Series 40 actuator or load	Two-position
60 Two position	Line voltage spdt equivalent of Series 40	Three-wire, line voltage	Any Series 60 actuator or load	Two-position, reversible
60 Floating	Line voltage spdt with center neutral or dual Series 40	Three-wire, low voltage	Any Series 60 actuator	Floating, reversible
80	Low voltage, spst equivalent of Series 40.	Two-wire, low voltage	Any Series 80 actuator or load	Two-position
90	Low voltage. Proportional action	Three-wire, low voltage	Any Series 90 actuator	Proportional

Table 1 lists and describes the basic control circuits. These basic circuits are frequently expanded to provide additional features such as:

1. High-limit override or control.
2. Low-limit override or control.
3. Minimum/maximum positioning of dampers and valves.
4. Manual reset.

The following paragraphs illustrate and discuss some of the more common applications. To make it easier to understand the control circuits, the simplest circuits (i.e., Series 40) are presented first.

SERIES 40 CONTROL CIRCUITS

APPLICATION

A Series 40 circuit is a line-voltage control circuit which is switched directly by the single-pole, single-throw switching action of a Series 40 controller. A Series 40 control circuit is two position and requires two wires. It can be used to control fans, electric motors, lights, electric heaters, and other standard line-voltage equipment in addition to relays and spring-return actuators.

The equipment controlled is energized when the controller switch is closed and deenergized when the switch is open.

Normally, a Series 40 controller closes and opens the circuit load directly. However, when a load exceeds the contact rating of the controller, an intermediate (pilot) relay with higher contact ratings must be used between the controller and the load circuit.

Also a relay can be used if a load circuit requires double- or multi-pole switching action. The Series 40 controller energizes the coil of the relay to actuate the contacts.

Series 40 controllers which operate at line voltage must be wired according to codes and ordinances for line-voltage circuits. Series 40 controllers when used to switch low voltage can be wired according to low-voltage circuit requirements.

EQUIPMENT

CONTROLLERS

1. Temperature controllers.
2. Pressure controllers.
3. Humidity controllers.
4. Other two-position devices that have a normally open or normally closed contact action such as a line-voltage relay.

In these controllers, either snap-acting or mercury switch contacts close and open the circuit. In most cases, Series 40 controllers are snap-acting. Series 40 controllers can be used in low-voltage circuits, but low-voltage controllers cannot be used in Series 40 line-voltage circuits.

RELAYS

A Series 40 relay consists of a line-voltage coil which operates an armature to control one or more normally open or normally closed, or single-pole, double-throw contacts.

ACTUATORS

Series 40 actuators usually operate valves or dampers. The actuator is electrically driven through its stroke (usually either 90 or 160 degrees) when the controller contact is closed. A limit switch in the motor opens at the end of the power stroke, the actuator stops, and the drive shaft is held in position by a solenoid brake (Fig. 4), or one of the motor windings (Fig. 5), as long as the circuit is closed. When the controller circuit opens or a power failure occurs, the solenoid brake (or motor winding) releases and an integral spring returns the actuator to the deenergized position. Series 40 actuators should be used in applications that do not require frequent cycling due to the high speed spring return.

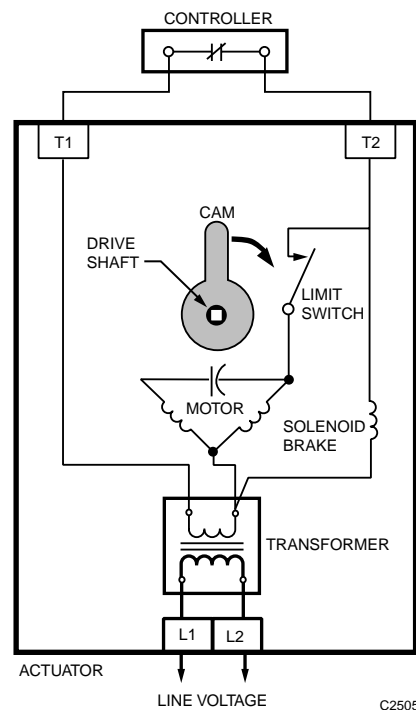

Fig. 4. Series 40 Actuator Circuit with Low-Voltage Motor.

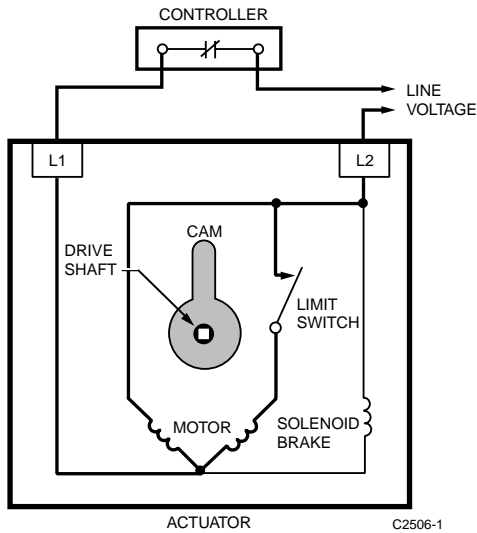

Fig. 5. Series 40 Actuator Circuit with Line-Voltage Motor.

Most Series 40 actuators have low-voltage motor coils and a built-in line-voltage to low-voltage transformer. Power to the unit is line voltage but the control circuit in the motor is normally low voltage. These actuators can use either a Series 40 line-voltage controller or a Series 80 low-voltage controller and are wired as shown in Figure 4. Series 40 controllers can also be used in the line-voltage supply to the actuator.

Some Series 40 actuators have line-voltage motor coils and can use either a Series 40 line-voltage controller or a Series 60 two-position controller (which is also line voltage) and are wired as shown in Figure 5.

OPERATION

- A simple Series 40 circuit is shown in Figure 6. It consists of:
1. A Series 40 (or 80) controller.
 2. A Series 40 actuator with low-voltage control circuit.

When the controller switch is closed as in Figure 6, the actuator drives to the open limit where it is held by the solenoid brake. When the controller switch is open, the actuator returns to its spring-return position. Series 80 controllers cannot be used with actuators having a line-voltage control circuit.

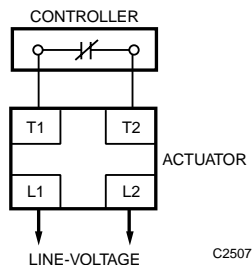

Fig. 6. Series 40 Control Circuit.

CONTROL COMBINATIONS

UNIT HEATER CONTROL

In unit heater control (Fig. 7) it is usually necessary to keep the heater fan from running to prevent circulation of cold air when heat is not being supplied to the heater coils.

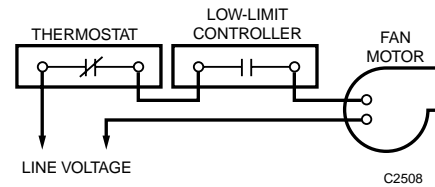

Fig. 7. Series 40 Unit Heater Control System.

The thermostat controls the fan motor from room temperature. The low-limit controller is a reverse-acting temperature controller installed with the sensing element in the steam or water return from the unit heater. It is connected in series with the thermostat and fan motor and prevents the fan from operating until the medium flow is established through the coil. With large fan motors, a relay must be added to handle the motor load.

HIGH-LIMIT CONTROL

Figure 8 shows a Series 40 thermostat and a high-limit controller operating a hot water valve. The thermostat controls the hot water valve from room temperature. The high-limit controller is located in the discharge of the heating coil to prevent excessive discharge air temperatures. The high-limit controller is wired in series with the thermostat and valve so that it opens the circuit to the valve on a rise in discharge temperature to the high-limit setting.

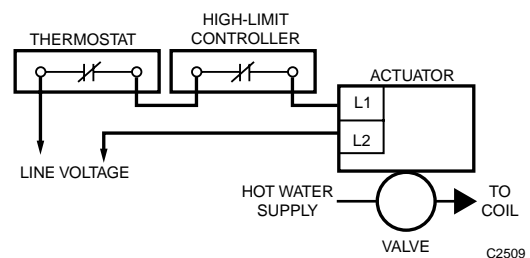

Fig. 8. Series 40 Control System with High Limit.

LOW-LIMIT CONTROL

A low-limit controller is connected in parallel with the thermostat as shown in Figure 9. The low-limit controller can complete the circuit to the valve actuator even though the thermostat has opened the circuit. The actuator remains energized when the contacts on either controller are closed.

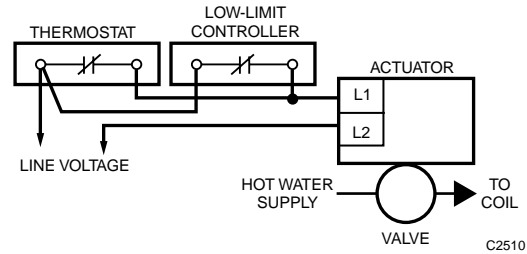

Fig. 9. Series 40 Control System with Low Limit.

SERIES 80 CONTROL CIRCUITS

APPLICATION

Series 80 is the low-voltage equivalent of Series 40. It is suited for applications requiring low-voltage, two-position control of two-wire circuits by single-pole, single-throw controllers.

Series 80 has two advantages over Series 40:

1. Since contacts of Series 80 controllers are required to carry less current, the controller mechanism can be physically smaller than a Series 40. The controller therefore has less lag and the capability to have a narrower differential.
2. Low-voltage wiring (when not in conduit or armor) costs less than line-voltage wiring.

EQUIPMENT

CONTROLLERS

1. Temperature controllers.
2. Humidity controllers.
3. Any low-voltage device with a minimum of one normally-open contact such as a low-voltage relay.

A Series 80 controller cannot switch line voltage directly. A relay must be used between the controller and a line-voltage load. However, Series 40 or Series 80 controllers can be used with Series 80 actuators.

A Series 80 controller has snap-acting contacts or a mercury switch. Some Series 80 controllers are three-wire, double-throw devices as in heating-cooling thermostats.

Many Series 80 heating thermostats have internal adjustable heaters in series with the load. This provides enough artificial heat during the on cycle to cause the sensing element to open the switch on a smaller rise in space temperature. Some Series 80 cooling thermostats have a fixed heater which energizes when the cooling circuit is deenergized. This provides artificial heat to the sensing element to close the switch on a small rise in space temperature. This cooling and heating anticipation (also called time proportioning) provides close space-temperature control. See the Control Fundamentals section.

RELAYS AND ACTUATORS

Relays and actuators are similar to those of Series 40 except that they operate on low voltage.

OPERATION

Figure 10 illustrates a simple Series 80 circuit. This is the same as a Series 40 circuit with the added transformer.

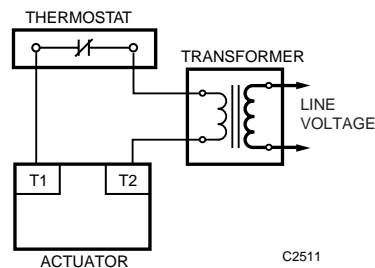

Fig. 10. Series 80 Actuator Application.

CONTROL COMBINATIONS

Series 80 control combinations are similar to those of Series 40. The following applies:

1. Series 80 circuits require an external, low-voltage transformer.
2. Series 80 equipment can be controlled by Series 40 or 80 controllers.
3. Series 80 controllers can control line-voltage actuators or other line-voltage devices by using a Series 80 relay with line-voltage contacts.

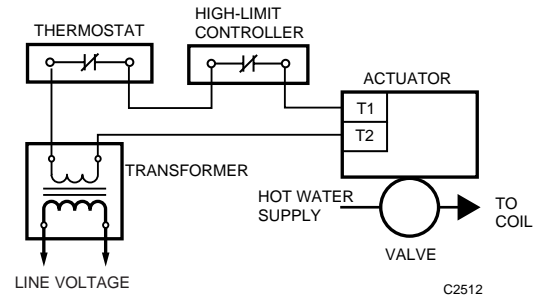

Fig. 11. High-Limit Control of Series 80 Solenoid Valve.

HIGH-LIMIT CONTROL

A Series 80 valve with high-limit controller is shown in Figure 11. The transformer supplies 24V ac to the circuit. The thermostat controls the heating valve actuator. The high-limit controller opens the circuit on a temperature rise to the high-limit setting. Contacts on both controllers must be closed to open the valve.

LOW-LIMIT CONTROL

Same as for Series 40 except that a transformer and a Series 80 actuator are used. See Figure 9.

SERIES 60 TWO-POSITION CONTROL CIRCUITS

APPLICATION

A Series 60 two-position control circuit is a line- or low-voltage circuit which requires a single-pole, double-throw controller to operate a reversible drive actuator. Series 60 two-position control circuits can be used for open-closed control of valves or dampers.

The basic Series 60 circuit contains a Series 60 actuator and a Series 60 controller. Limit controllers can be added where required.

EQUIPMENT

CONTROLLERS

1. Temperature controllers.
2. Humidity controllers.
3. Pressure controllers.
4. Any single-pole, double-throw controller such as a relay or switch.

Series 60 two-position controllers are line-voltage rated devices and have a spdt switching action that is obtained by use of a mercury switch or snap-acting contacts. Series 60 controllers can operate line- or low-voltage devices.

ACTUATORS

Series 60 actuators consist of a low-voltage, reversible motor which operates a gear train to rotate a drive shaft. The actuator drives open and closed by switching voltage input to the motor, not depending on a spring to close. Built-in limit switches stop the motor at open and closed positions of the actuator stroke. The drive shaft is mechanically connected to the damper or valve by a suitable linkage. On power interruption or loss of control signal, the actuator maintains its current position between limits. This allows the actuator to be used in either two-position applications or floating applications (see SERIES 60 FLOATING CONTROL CIRCUITS).

Most Series 60 actuators have low-voltage motors. Line-voltage models will often have a built-in transformer to change the incoming line voltage to low voltage for the control circuit and the motor. Low-voltage models require an external transformer to supply voltage to the actuator. See Figure 12. Some Series 60 actuators have line-voltage motors.

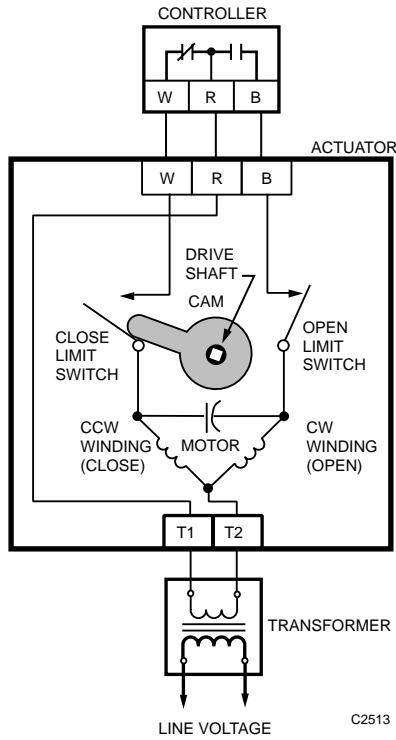

Fig. 12. Series 60 Two-Position Control Circuit.

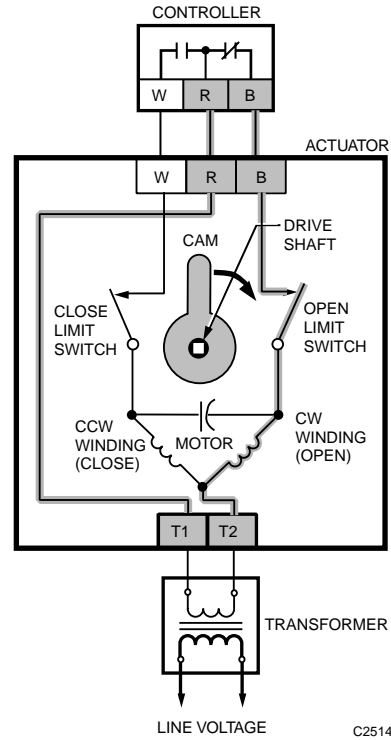

Fig. 13. Series 60 Initial Control Action on a Temperature (or Pressure) Drop.

Low-voltage controllers cannot be used on line-voltage control circuits. If the control circuit is low voltage, it can use either a line-voltage controller or any low-voltage, spdt, or floating controller.

OPERATION

Figure 12 illustrates the actuator in the closed position. On a drop in temperature or pressure, the controller contacts close R to B and open R to W (Fig. 13). The OPEN winding is energized and the actuator shaft rotates cw until it reaches the limit of travel and opens the OPEN limit switch (Fig. 14). The actuator remains in this position until a rise in temperature or pressure causes the controller contacts R to B to open and R to W to close. The CLOSE coil is then energized and the actuator shaft rotates ccw until it reaches the limit of travel and opens the CLOSE limit switch.

NOTE: Most Honeywell Series 60 controllers close R to B on a fall in the controlled variable and R to W on a rise.

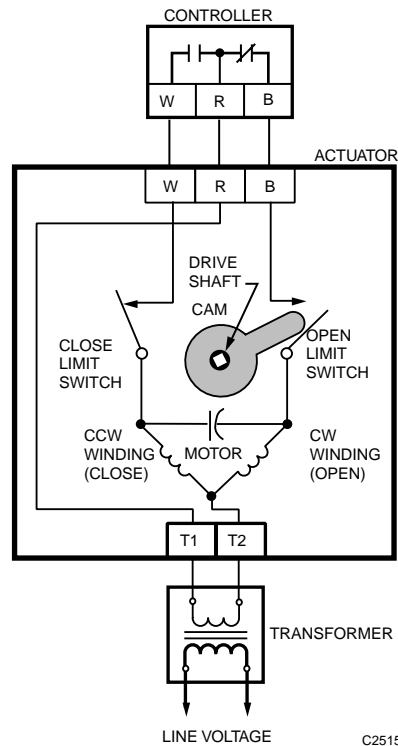

Fig. 14. Series 60 Final Control Action at End of Open Stroke.

CONTROL COMBINATIONS

The following are representative Series 60 two-position control circuits. Notice that many of these functions can be done with Series 40 or 80 systems. If spring-return action is required when power fails, use Series 40 or 80.

TWO-POSITION CONTROL OF STEAM VALVE

Figure 15 illustrates two-position control of a steam valve. During the day when the temperature sensed by the Series 60 controller drops below the setpoint, contacts R to B close and the actuator opens the valve allowing the steam to flow to the coil. On a rise in temperature, contacts R to W close and the actuator closes the valve stopping the flow of steam. At night the time clock overrides the temperature controller and drives the actuator/valve closed.

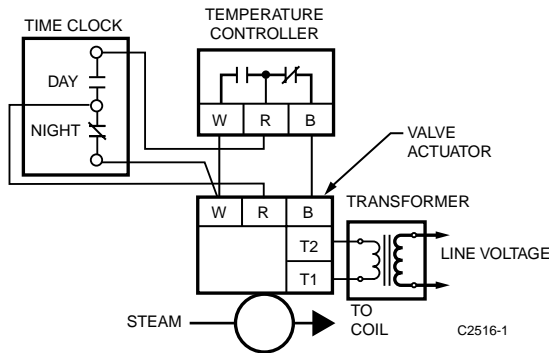

Fig. 15. Series 60 Two-Position Control of Steam Valve with Time clock Override.

SUMMER/WINTER CHANGEOVER CONTROL OF A THREE-WAY DIVERTING VALVE

Figure 16 illustrates summer/winter changeover control of a three-way diverting valve. A Series 60 controller senses outdoor air temperature to determine when to change over from heating to cooling. When the outdoor air temperature drops below the setpoint of the controller, contacts R to W open and R to B close calling for winter operation. The low-limit controller, located in the return water line, senses the return-water temperature. If the water temperature is above the setpoint of the low limit controller, the R to B circuit completes, and the actuator positions the diverting valve to send the return water to the boiler. If the low-limit controller senses that the return water is too cool, the contacts open, and the valve remains in a position to divert the return water through the chiller. This circuit protects the boiler from thermal shock by not allowing chilled water into the hot boiler.

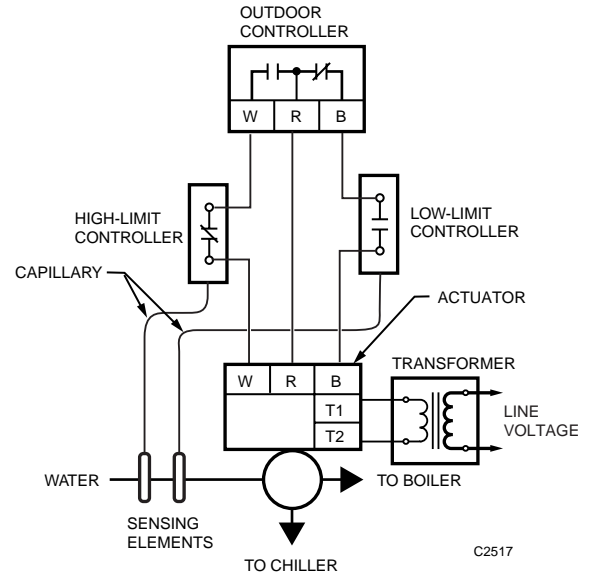

Fig. 16. Series 60 Summer/Winter Changeover Control of Diverting Valve.

When the outdoor air temperature rises above the setpoint of the controller, contacts R to B open and R to W close calling for summer operation. If the water temperature is below the setting of the high limit, the R to W circuit completes, and the actuator positions the diverting valve to send the return water to the chiller. If the high-limit controller senses that the return water is too warm, the contacts open, and the valve remains in a position to divert the return water through the boiler. This circuit protects the chiller by not allowing hot water into the chiller.

OPEN-CLOSED CONTROL OF DAMPER

Figure 17 illustrates open-closed control of a damper. A Series 60 actuator is linked to a ventilating damper. When the controller senses that the temperature in the interior of the building is above the controller setpoint, contacts R to B open and R to W close. This powers the R to B actuator terminals causing the actuator shaft to turn, opening the dampers. When the controller senses that the temperature is below the setpoint, contacts R to W open and R to B close causing the actuator shaft to close the damper.

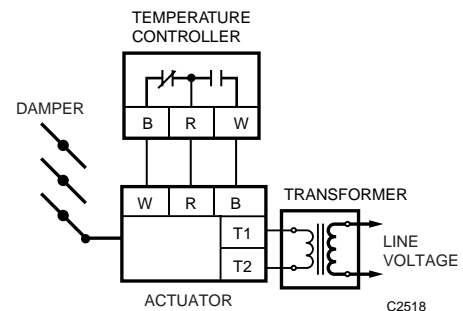

Fig. 17. Series 60 Open-Closed Control of Damper.

SERIES 60 FLOATING CONTROL CIRCUITS

APPLICATION

A Series 60 floating control circuit is a line- or low-voltage control circuit comprising a spdt controller with a center-off (floating) position and a reversible actuator. On a change in the controlled variable, the controller drives the actuator to an intermediate position and then opens the circuit to the actuator. The actuator remains in this position until a further change at the controller. The actuator is said to float between the limits of the controller to satisfy various load requirements. In many systems, Series 60 floating control provides adequate modulating control.

To provide stable Series 60 floating control, careful consideration must be given to the speed of response of the controller and the timing of the actuator. For a given change in the system, the actuator timing and the subsequent change in the controlled variable must be slower than the response time of the controller. To accomplish this, Series 60 actuators are available with various drive speeds.

Series 60 floating control circuits can be used for:

1. Control of two-way or three-way valves.
2. Control of dampers.
3. Control of inlet vane or other static pressure regulating equipment.

The basic Series 60 floating control circuit consists of a Series 60 actuator and a Series 60 floating controller. Various limit controllers can be added where required.

EQUIPMENT

CONTROLLERS

1. Floating temperature controllers.
2. Floating pressure controllers.
3. Simulated Series 60 floating control using two Series 40 or 80 controllers.

Series 60 floating controllers are three-wire, line- or low-voltage devices with a spdt switching action and a center off position.

ACTUATORS

The actuators discussed in SERIES 60 TWO-POSITION CONTROL are also used for floating control. In addition, actuator assemblies are available with two, single direction motors driving a common shaft. One motor drives the shaft in one direction, and the other motor drives the shaft in the other direction.

OPERATION

Operation of the Series 60 floating control circuit is similar to that discussed in SERIES 60 TWO-POSITION CONTROL with one major difference: the controller has a center off position allowing the actuator to stop at positions between the open limit and the close limit.

CONTROL COMBINATIONS

Series 60 floating control can be used to regulate static or differential pressures in applications where the pressure pickup can sense changes and position a damper actuator at intermediate locations between open and closed. Figure 18 illustrates a static pressure controller connected to a Series 60 damper actuator. A drop in static pressure to the controller setpoint closes R to B at the controller and causes the actuator to drive toward open. As soon as the static pressure increases above the setpoint, R to B opens and the actuator stops. The moveable contact R of the controller remains at the center or neutral position until a further drop causes the actuator to open the damper further. On a rise in static pressure to the setpoint plus a differential, or dead band, R to W closes driving the actuator toward closed. When the controller is satisfied, R to W opens stopping the actuator. Thus, the damper actuator floats between open and closed limits to maintain static pressure.

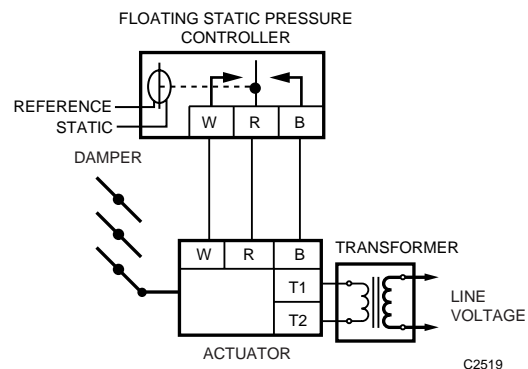

Fig. 18. Series 60 Floating Control.

SERIES 90 CONTROL CIRCUITS

APPLICATION

The Series 90 low-voltage control circuit provides modulating or proportional control and can be applied to:

- Motorized valves.
- Motorized dampers.
- Sequence switching mechanisms.

The Series 90 circuit can position the controlled device (usually a motorized damper or valve) at any point between full-open and full-closed to deliver the amount of controlled variable required by the controller.

Proportional control, two-position control, and floating control have different operating limitations. For example:

1. In modulating control, when an actuator is energized, it moves the damper or valve a distance proportional to the sensed change in the controlled variable. For example, a Series 90 thermostat with a 5 kelvins throttling range moves the actuator 1/5 of the total travel for each degree change in temperature.
2. In two-position control, when an actuator is energized it moves the valve or damper to one of the extreme positions. The valve or damper position remains unchanged until conditions at the controller have moved through the entire range of the differential.
3. In floating control, when an actuator is energized, it moves the damper or valve until the controller is satisfied. The actuator maintains that position until the controller senses a need to adjust the output of the valve or damper.

Series 90 circuits combine any Series 90 controller with an actuator usable for proportioning action. Limit controls can also be added.

EQUIPMENT

CONTROLLERS

- Temperature controllers.
- Humidity controllers.
- Pressure controllers.
- Manual positioners.

Series 90 controllers differ from controllers of other series in that the electrical mechanism is a variable potentiometer rather than an electric switch. The potentiometer has a wiper that moves across a 135-ohm coil of resistance wire. Typically the wiper is positioned by the temperature, pressure, or humidity sensing element of the controller.

ACTUATORS

A Series 90 actuator (Fig. 19) consists of the following:

- Reversible drive motor.
- Electronic relay.
- Switching triacs.
- Feedback potentiometer.
- Gear train and drive shaft.
- Rotation limit switches.
- Optional spring-return mechanism.

The actuator has a low-voltage, reversible-drive motor which turns a drive shaft by means of a gear train. Limit switches limit drive shaft rotation to 90 or 160 degrees depending on the actuator model. The motor is started, stopped, and reversed by the electronic relay.

The feedback potentiometer is electrically identical to the one in the controller and consists of a resistance path and a movable wiper. The wiper is moved by the actuator drive shaft and can travel from one end of the resistance path to the other as the actuator drive shaft travels through its full stroke. For any given position of the actuator drive shaft, there is a corresponding position for the potentiometer wiper.

All Series 90 actuators have low-voltage motors. A line-voltage model has a built-in transformer to change the incoming line voltage to low voltage for the control circuit and the motor. Low-voltage models require an external transformer to supply the actuator (Fig. 19).

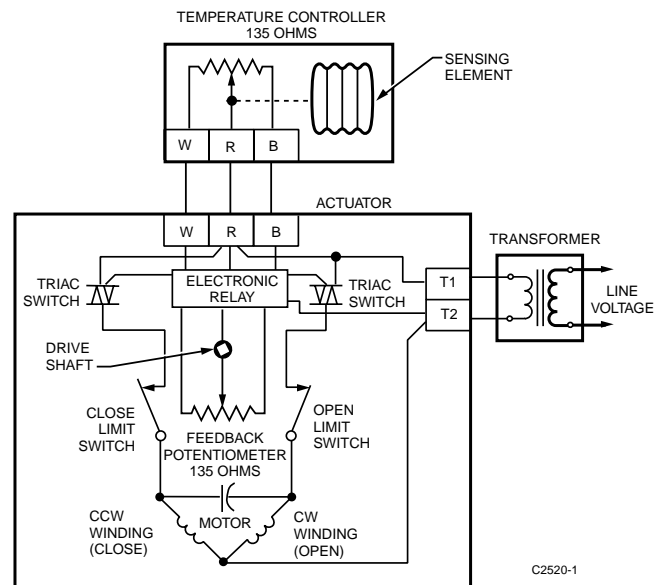

Fig. 19. Series 90 Actuator Circuit.

OPERATION

GENERAL

Figure 19 illustrates a basic Series 90 system including a temperature controller, actuator, and transformer. The wiper of the potentiometer on the controller is at the midpoint and the actuator drive shaft is at midposition when the controlled variable is at the setpoint. The shaft remains unchanged until the controlled variable increases or decreases. The amount the controlled variable must change to drive the actuator drive shaft from full closed to full open (or vice versa) is called the throttling range. The setpoint and the throttling range are usually adjustable at the controller.

The controller and feedback potentiometer form a bridge circuit which operates switching triacs through an electronic relay. When the controlled variable changes, the potentiometer wiper in the controller moves and unbalances the bridge circuit. The electronic relay detects the unbalance and triggers the appropriate switching triac. The triac drives the actuator drive shaft and feedback potentiometer wiper in the direction necessary to correct the unbalance. When the electronic relay detects that the bridge is rebalanced, the triac is switched off and the actuator drive shaft stops at the new position. If the actuator drive shaft drives to the full open or full closed position, the appropriate limit switch stops the motor.

For example, in a heating application a fall in temperature causes the controller potentiometer wiper R to move from W toward B. This unbalances the bridge and drives the actuator toward open. The actuator drive shaft and feedback potentiometer wiper R drives cw toward open until the bridge is rebalanced. The actuator drive shaft and feedback potentiometer then stop at a new position. On a rise in temperature, the actuator drive shaft and feedback potentiometer drive ccw toward closed stopping at a new position.

To reverse the action of the actuator, the W and B leads can be reversed at either the actuator or the controller. The actuator then drives toward the closed position as the potentiometer wiper at the controller moves toward B on a fall in the controlled variable and toward the open position as the potentiometer wiper moves toward W on a rise in the controlled variable. These connections are typically used in a cooling application.

NOTE: Most Honeywell Series 90 controllers move the potentiometer wiper toward B on a fall in the controlled variable and toward W on a rise.

BRIDGE CIRCUIT THEORY

The following sections discuss basic bridge circuit theory and limit controls as applied to Series 90 control. The drawings illustrate only the bridge circuit and electronic relay, not the triacs, motor coils, and transformer. Potentiometers are referred to as having 140 or 280 ohms for ease of calculation in the examples. These potentiometers are actually 135- or 270-ohm devices.

Basic Bridge Circuit

BRIDGE CIRCUIT IN BALANCED CONDITION

Figure 20 illustrates the bridge circuit in a balanced condition. For the bridge to be balanced, R1 plus R3 must equal R2 plus R4. R1 plus R3 is referred to as the left or W leg of the bridge, and R2 plus R4, the right or B leg of the bridge. In this example, each resistance in the left leg, R1 and R3, is 70 ohms. Together they equal 140 ohms. Similarly, each resistance in the right leg, R2 and R4, is 70 ohms. Together they also equal 140 ohms. Since the sums of the resistances in the two legs are equal, the bridge is in balance. This is shown in the following table:

	Left Leg	Right Leg
Controller potentiometer	70	70
Feedback potentiometer	<u>70</u>	<u>70</u>
Total	140	140

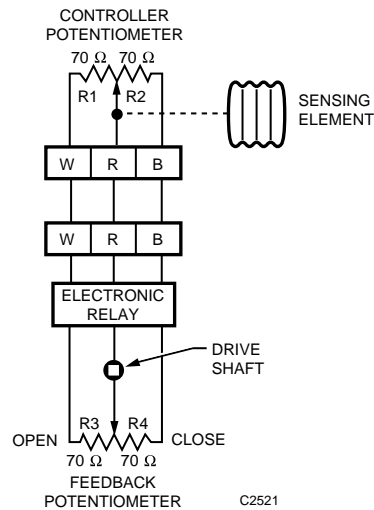

Fig. 20. Bridge Circuit in Balanced Condition.

When the bridge is balanced, neither triac is triggered, neither motor winding is energized, and the actuator drive shaft is stopped at a specified point in its stroke (the midposition or setpoint in this case).

BRIDGE CIRCUIT ON INCREASE IN CONTROLLED VARIABLE

Figure 21 illustrates the bridge circuit in an unbalanced condition on an increase in the controlled variable. The controller potentiometer wiper has moved to one-fourth the distance between W and B but the feedback potentiometer wiper is at the center. This causes an unbalance of 70 ohms (175 – 105) in the right leg as follows:

	Left Leg	Right Leg
Controller potentiometer	35	105
Feedback potentiometer	<u>70</u>	<u>70</u>
Total	105	175

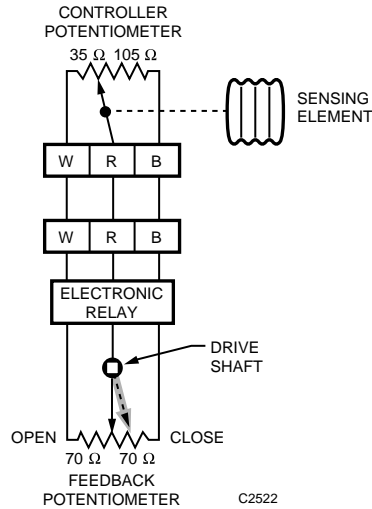

Fig. 21. Bridge Circuit on Increase in Controlled Variable.

The unbalance causes the electronic relay to trigger the left triac, energize the ccw motor winding, and drive the actuator drive shaft toward closed. Since half of the 70-ohm unbalance has to go on each side of the bridge to rebalance the circuit, the feedback potentiometer will move 35 ohms to the right. The table then appears as follows:

	Left Leg	Right Leg
Controller potentiometer	35	105
Feedback potentiometer	<u>105</u>	<u>35</u>
Total	140	140

When the feedback potentiometer reaches the new position (shown dotted) the bridge is rebalanced, the left triac turns off, and the actuator drive shaft stops in the new position (25 percent open).

BRIDGE CIRCUIT ON DECREASE IN CONTROLLED VARIABLE

Figure 22 illustrates the bridge circuit in an unbalanced condition on a decrease in the controlled variable. The controller potentiometer wiper R has moved all the way to the B end and the feedback potentiometer wiper is at the center. This causes an unbalance of 140 ohms (210 – 70) in the left leg as shown:

	Left Leg	Right Leg
Controller potentiometer	140	0
Feedback potentiometer	<u>70</u>	<u>70</u>
Total	210	70

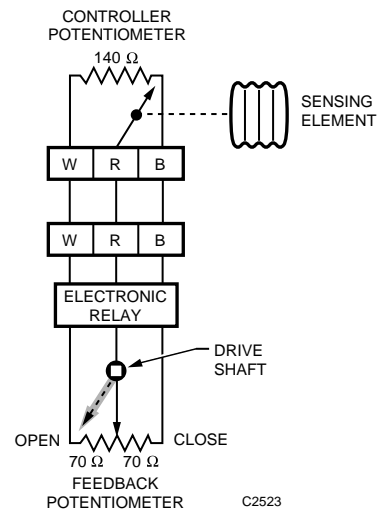

Fig. 22. Bridge Circuit on Decrease in Controlled Variable.

The unbalance causes the electronic relay to trigger the right triac (Fig. 19), energize the cw motor winding, and drive the actuator drive shaft toward open. Since half of the 140-ohm unbalance has to go on each side of the bridge to rebalance the circuit, the feedback potentiometer will move 70 ohms to the left. The table then appears as follows:

	Left Leg	Right Leg
Controller potentiometer	140	0
Feedback potentiometer	<u>0</u>	<u>140</u>
Total	140	140

When the feedback potentiometer reaches the new position (shown dotted) the bridge is rebalanced, the right triac turns off, and the actuator drive shaft stops in the new position (100 percent open).

BRIDGE CIRCUIT WITH LIMIT CONTROLS

Limit controls are commonly used to prevent the discharge air temperature of a central fan system from becoming too low or too high. Figures 23 and 24 illustrate limit controls in a heating application. These controls add resistance in the bridge circuit and drive the actuator toward the open position if a low-limit condition is approached (Fig. 23) or toward the closed position if a high-limit condition is approached (Fig. 24).

Limit controllers can have either a 140- or a 280-ohm potentiometer. The 140-ohm potentiometer can drive an actuator only half-way open (or closed) since it adds resistance into one leg of the bridge but does not subtract resistance from the other leg. If 100 percent control is required from a limit controller, a 280-ohm potentiometer device should be used. The following examples are for limit controls with 140-ohm potentiometers.

BRIDGE CIRCUIT WITH LOW-LIMIT CONTROL

In a heating application, a low-limit controller moves a valve actuator toward open when the low-limit setting is reached. To do this, the limit controller is wired into the left or W leg of the bridge. An increase in resistance in the left leg of the controller circuit drives the actuator and feedback potentiometer toward the open position.

In Figure 23, when the controller and the low limit are satisfied (both potentiometer wipers at the W ends), the actuator is at the closed position and the bridge is balanced. This is shown in the following table:

	Left Leg	Right Leg
Controller potentiometer	0	140
Low-limit potentiometer	0	0
Feedback potentiometer	<u>140</u>	<u>0</u>
Total	140	140

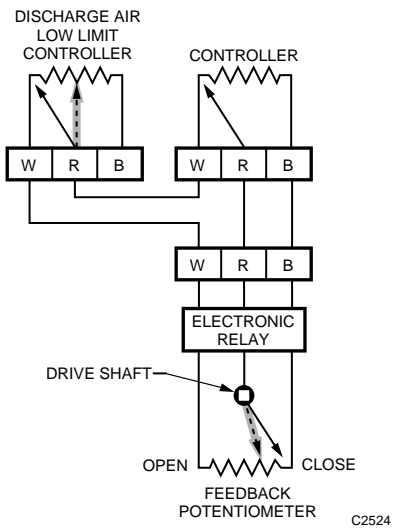

Fig. 23. Bridge Circuit with Low-Limit Control.

When the low-limit controller calls for more heat, the potentiometer wiper R (shown dotted) moves halfway from W to B. This causes an unbalance of 70 ohms (210 – 140) in left leg of the bridge as shown in the following table:

	Left Leg	Right Leg
Controller potentiometer	0	140
Low-limit potentiometer	70	0
Feedback potentiometer	<u>140</u>	<u>0</u>
Total	210	140

The unbalance causes the electronic relay to trigger the right triac, energize the cw motor winding, and drive the actuator drive shaft toward open. Since half of the 70-ohm unbalance

has to go on each side of the bridge to rebalance the circuit, the feedback potentiometer moves 35 ohms to the left. The table then appears as follows:

	Left Leg	Right Leg
Controller potentiometer	0	140
Low-limit potentiometer	70	0
Feedback potentiometer	<u>105</u>	<u>35</u>
Total	175	175

When the feedback potentiometer reaches the new position (shown dotted) the bridge is rebalanced, the right triac turns off, and the actuator drive shaft stops in the new position (25 percent open).

BRIDGE CIRCUIT WITH HIGH-LIMIT CONTROL

In a heating application, a high-limit controller moves a valve actuator toward closed when the high-limit setting is reached. To do this, the limit controller is wired into the right or B leg of the bridge. An increase in resistance in the right leg of the controller circuit drives the actuator and feedback potentiometer towards the closed position.

In Figure 24, when the controller and high limit are satisfied (both potentiometer wipers at the B ends), the actuator is at the open position and the bridge is balanced. This is shown in the following table:

	Left Leg	Right Leg
Controller potentiometer	140	0
High-limit potentiometer	0	0
Feedback potentiometer	<u>0</u>	<u>140</u>
Total	140	140

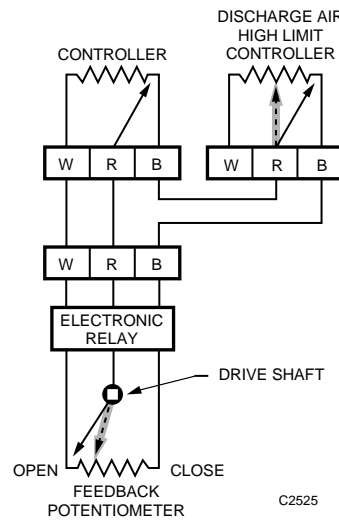

Fig. 24. Bridge Circuit with High-limit Control.

When the high-limit controller calls for less heat, the potentiometer wiper R (shown dotted) moves halfway from B to W. This causes an unbalance of 70 ohms (210 – 140) in the right leg of the bridge as shown in the following table:

	Left Leg	Right Leg
Controller potentiometer	140	0
High-limit potentiometer	0	70
Feedback potentiometer	<u>0</u>	<u>140</u>
Total	140	210

The unbalance causes the electronic relay to trigger the left triac, energize the ccw motor winding, and drive the actuator drive shaft toward closed. Since half of the 70-ohm unbalance has to go on each side of the bridge to rebalance the circuit, the feedback potentiometer moves 35 ohms to the right. The table then appears as follows:

	Left Leg	Right Leg
Controller potentiometer	140	0
High-limit potentiometer	0	70
Feedback potentiometer	<u>35</u>	<u>105</u>
Total	175	175

When the feedback potentiometer reaches the new position (shown dotted) the bridge is rebalanced, the left triac turns off, and the actuator drive shaft stops in the new position (75 percent open).

CONTROL COMBINATIONS

The following illustrates common applications of Series 90 controls including low- and high-limit controls from an application viewpoint.

LOW-LIMIT CONTROL

Figure 25 illustrates a typical Series 90 circuit for a heating application with a room controller, motorized valve, and a low-limit controller located in the discharge air to the space. The temperature of the space can rise rapidly as a result of increased solar radiation, occupancy, or other conditions resulting in a sudden decrease in heating load. The room controller is then satisfied and closes the valve to the heating coil. If the system uses outdoor air, closing the valve to the heating coil can cause air to be discharged into the room at a temperature lower than desirable. To correct this, the low-limit controller causes the valve to move toward open thus limiting the low temperature of the discharge air.

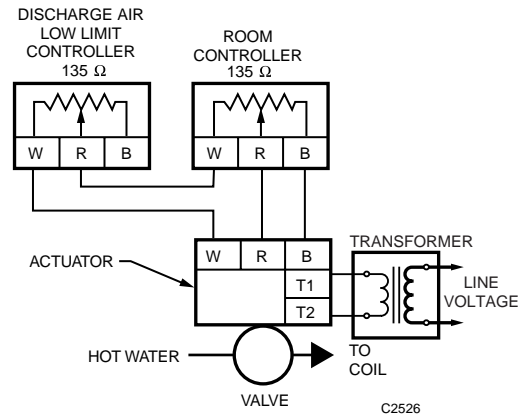

Fig. 25. Series 90 Circuit with Low-Limit Control.

HIGH-LIMIT CONTROL

Figure 26 illustrates a typical Series 90 circuit for a heating application with a room controller, motorized valve, and high-limit controller located in the discharge air to the space. This circuit is used when there is danger of the temperature rising too high. The high-limit controller takes over control of the valve to the heating coil if the discharge air temperature rises above a comfortable level. This circuit is similar to the low-limit circuit except that the high-limit controller is in the B leg of the actuator circuit and drives the actuator toward the closed position.

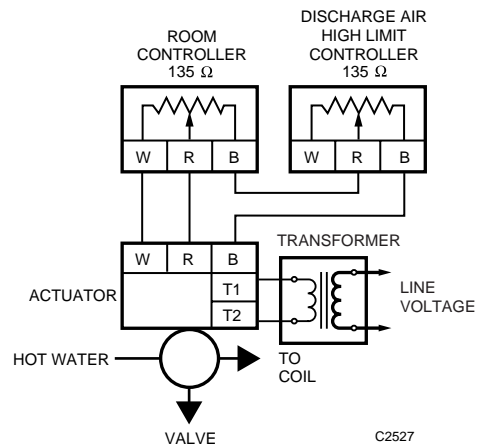

Fig. 26. Series 90 Circuit with High-Limit Control.

TWO-POSITION LIMIT CONTROL

Two-position limit controllers can be used in Series 90 circuits where proportioning action is unnecessary or undesirable. They must be snap-acting, spdt. Two-position controls should not be used where the temperature of the controlled variable is greatly affected by the opening and closing of the controlled valve or damper. For example, if Series 60 high- or low-limit controllers are used as limit controllers in discharge air, whenever the temperature of the air is within the range of the limit controller, the steam valve for the heating coil will cycle on and off continuously.

Figure 27 illustrates a Series 90 circuit with a temperature controller, normally closed (spring-return actuator) cooling valve, and a two-position, high-limit humidity controller. When the humidity is below the setting of the high-limit humidity controller, the R circuit is completed from the Series 90 controller to the actuator and the cooling valve is controlled normally. If the humidity rises above the setting of the limit controller, R to B is connected at the actuator and the cooling valve opens fully. Reheat is advisable in a system of this kind since opening the cooling valve to reduce humidity also lowers the temperature of the air and may result in occupant discomfort.

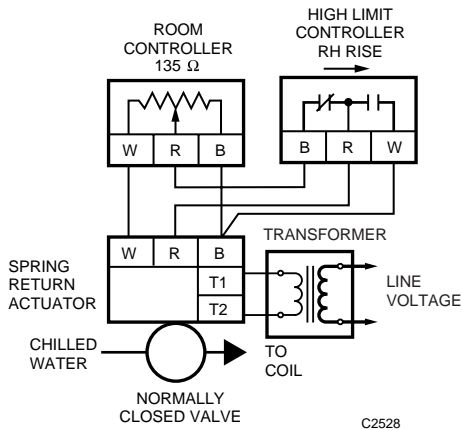

Fig. 27. Diagram of Series 90 Circuit with Two-Position, High-Limit, Humidity Controller.

MANUAL AND AUTOMATIC SWITCHING

Figures 28 through 31 illustrate various uses of manual switches or relays in Series 90 circuits. Substitute a relay with the same switching action as a manual switch where automatic switching is desired.

Closing the Actuator with a Manual Switch

Figure 28 shows a manual switch with spdt switching action. With the switch in auto position, the R circuit is completed from the controller to the actuator. The actuator operates normally under control of the controller. Placing the switch in the closed position (dotted arrow) opens the R circuit from

the controller and shorts R to W at the actuator. The actuator drives to the closed position. Such a hookup is often used in fan heating systems to manually close a valve or damper when operation is unnecessary.

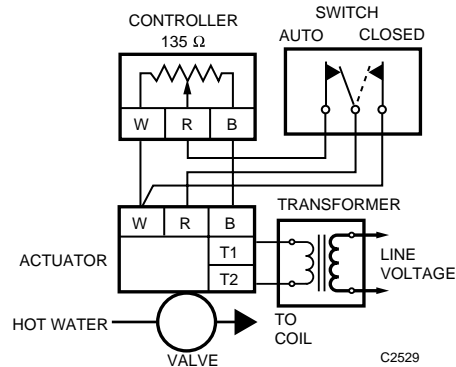

Fig. 28. Series 90 Circuit with SPDT Switch for Automatic or Manual Operation.

Transferring Actuator Control from One Thermostat to Another

Figure 29 illustrates using a dpdt switch or time clock to transfer control of a single Series 90 actuator from one thermostat to another. Opening both the W and B wires prevents interaction of the two thermostats when taking one of them out of control. The R wire need not be opened.

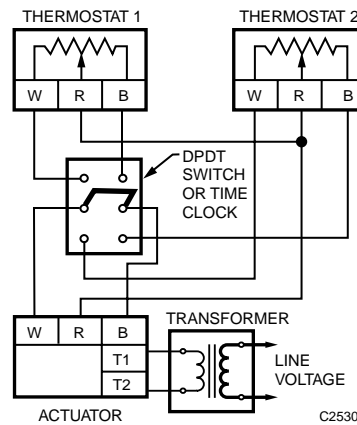

Fig. 29. Circuit for Transferring a Series 90 Actuator from One Thermostat to Another.

Reversing for Heating and Cooling Control

Figure 30 shows a thermostat used for both heating and cooling control. With the switch in the heating position, the thermostat and actuator are wired B to B and W to W. With the switch in the cooling position they are wired B to W and W to B which causes the actuator to operate the opposite of heating control.

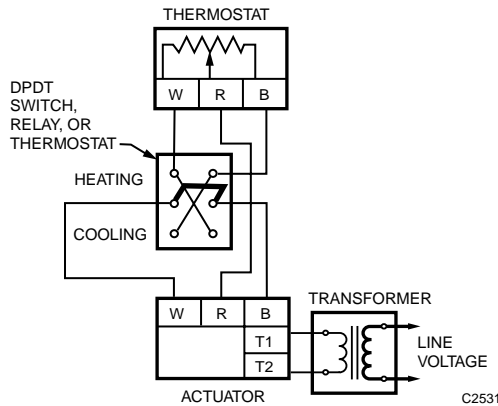

Fig. 30. Circuit Used for Reversing Heating and Cooling Control.

Transferring Controller from One Actuator to Another

Figure 31 illustrates a circuit which allows a single controller to control two Series 90 actuators, one at a time. With the 3pdt switch in the Cooling (C) position, the circuit connects the controller to the cooling actuator with B to W and W to B. The cooling actuator operates under normal control of the controller. At the same time, the manual switch causes R to W to connect at the heating actuator, positively closing it. With the switch in the Heating (H) position, the controller is connected B to B and W to W to the heating actuator which operates normally and the cooling actuator is positively closed by a R to W connection at the actuator.

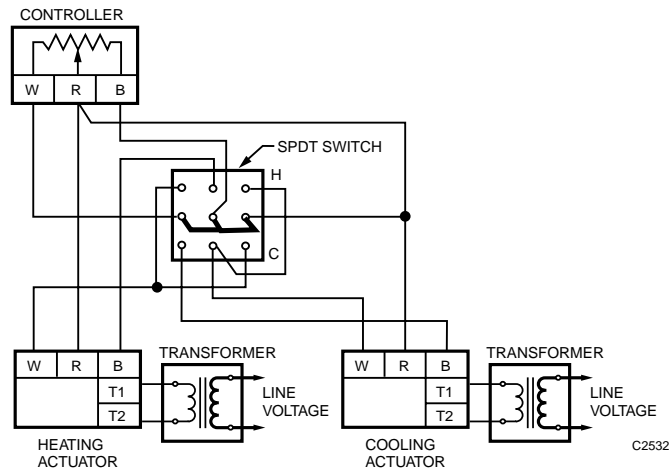

Fig. 31. Circuit for Transferring Controller from One Actuator to Another.

UNISON CONTROL

Figure 32 illustrates a circuit for controlling up to six Series 90 actuators in unison from one Series 90 controller. The B to W terminals of the controller are shunted with the appropriate value resistor, depending on the number of actuators in the circuit. This method can control a large bank of dampers requiring more torque than can be provided from a single actuator.

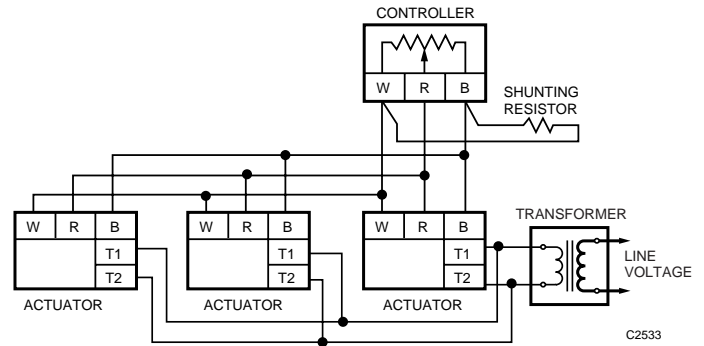

Fig. 32. Actuators Controlled in Unison from One Controller.

MANUAL MINIMUM POSITIONING OF OUTDOOR AIR DAMPER

Figure 33 illustrates a circuit for a typical outdoor air damper control system with a manual potentiometer for minimum positioning. Adjusting the potentiometer so that the wiper is at W shorts the potentiometer coil out of the circuit and the outdoor air damper actuator operates normally. The damper closes completely if commanded by the controller. Moving the potentiometer wiper toward B increases the resistance between B on the controller and W on the actuator to limit the travel of the actuator toward closed. The damper remains at the set minimum position even though the controller is trying to close it completely.

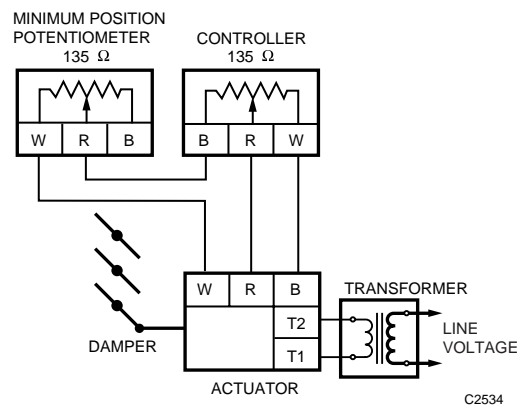

Fig. 33. Manual Minimum Positioning of Outdoor Air Damper.

A 135-ohm manual potentiometer provides up to a 50 percent minimum-position opening, and a 270-ohm manual potentiometer provides up to a 100 percent minimum-position opening.

STEP CONTROLLERS

A step controller consists of a series of switches operated sequentially by cams on a crankshaft. Figure 34 illustrates a Series 90 step controller used to stage electric heating elements or compressors. The step controller crankshaft is positioned by a Series 90 actuator through an interconnecting linkage. When heat is called for at the thermostat, the actuator turns the electric heat elements on in sequence. When less heat is required, the electric heat elements turn off in reverse sequence. If power is interrupted, a spring return in the actuator cycles the step controller to the no-heat position. As power resumes, the loads recycle in sequence to the level called for by the thermostat. The recycle feature assures that the starting loads will not overload the power line.

In some Series 90 step controllers, the recycle feature is accomplished with a relay rather than a spring-return actuator. On resumption of power, after an interruption, the relay deenergizes the loads, drives the controller to the no-heat position

position, and then permits the step controller to recycle to the position called for by the thermostat.

Step controllers can also be actuated by Series 60 floating controllers.

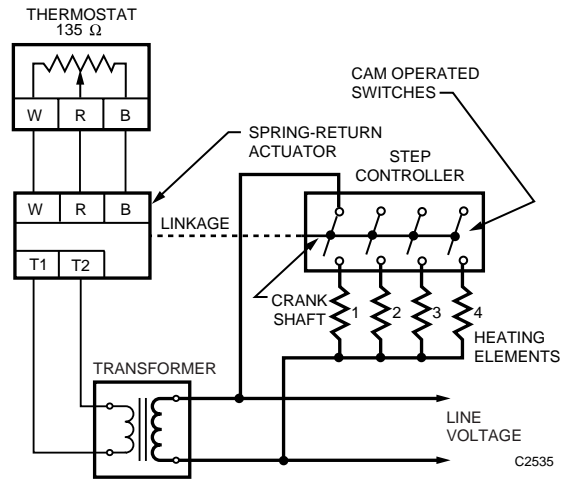

Fig. 34. Typical Step Controller System.

MOTOR CONTROL CIRCUITS

APPLICATION

Motor control circuits are used to:

1. Start and stop motors.
2. Provide electric overload and low-voltage protection.
3. Provide interlocks for human safety, equipment protection, and integration with the temperature control system.

EQUIPMENT

STARTERS

The starter is a motor load switching device having one or more load switching contacts and optional, auxiliary, pilot-duty contacts. All contacts are closed by a solenoid which pulls in an armature. Starters are provided to control high current and/or voltage for single and multiple phase motors from a single, low-current and/or voltage contact or switch.

A starter also contains thermal overloads in series with the load contacts. In the event of prolonged excess current draw through any of the load contacts, the overload contact opens, deenergizing the solenoid and stopping the motor. After the overload has cooled and/or the problem has been corrected, the overload reset button can restart the motor.

Starters can also contain a transformer to provide reduced voltage to power the starter control circuit. In addition, they can contain a manual hand-off-auto switch, a push-button start/stop switch, and auxiliary switching contacts.

CONTACTORS AND RELAYS

Relays are load switching devices similar to starters but without thermal overloads. Contactors are heavy-duty relays. These devices switch electric heaters or other equipment that have independent safety and overload protection.

OPERATION

Three basic types of motor control circuits are discussed in the following. This topic is only intended to illustrate general principles. There are many variations for each of these of circuits.

MOMENTARY START-STOP CIRCUIT

Figure 35 illustrates a momentary push-button start-stop circuit. Both the START and the STOP buttons are spring loaded and return to the positions shown after pressing momentarily. Pressing the START button completes a circuit energizing starter solenoid M. Contacts 1M through 3M start the motor and contact 4M forms a holding circuit across the START button allowing it to be released. Pressing the STOP button opens the holding circuit, drops out the starter coil M, and stops the motor. For digital control N.C. and N.O. momentarily actuated relay contacts under computer control are added to the start and stop contacts circuit. The N.C. contact is in series with the stop contact and the N.O. contact is in parallel with the start contact. An overload in any of the motor coils causes the associated overloads OL to heat up and open the OL contacts, opening the holding circuit, and stopping the motor. Overloads are thermal heaters which allow brief periods of significant overload but their response is too slow to protect the electrical system from a short circuit. The circuit shown includes a separate manually operated, fused (F), line disconnect, for short circuit protection.

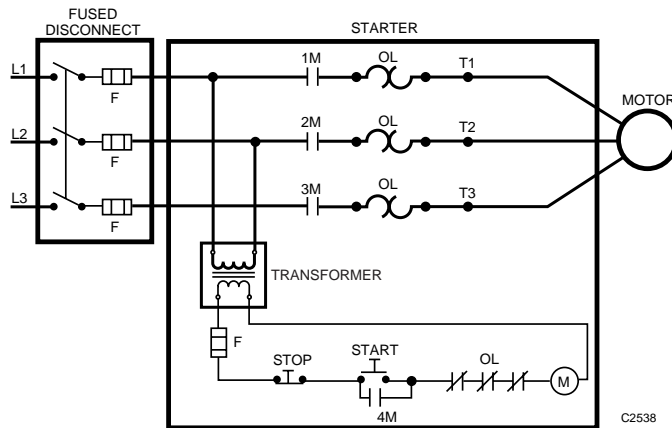

Fig. 35. Momentary Push-button Start-Stop Circuit.

HAND-OFF-AUTO START-STOP CIRCUIT

The starter switch in Figure 36 has three positions: HAND, OFF, and AUTO. The HAND position energizes starter solenoid M and starts the motor. The OFF position deenergizes starter solenoid M and stops the motor. The AUTO position allows the motor to be turned on or off as called for by an operating control device (interlock) such as a thermostat, pressure controller, or relay contact. This is the preferred starter circuit when the motor load is under automatic control.

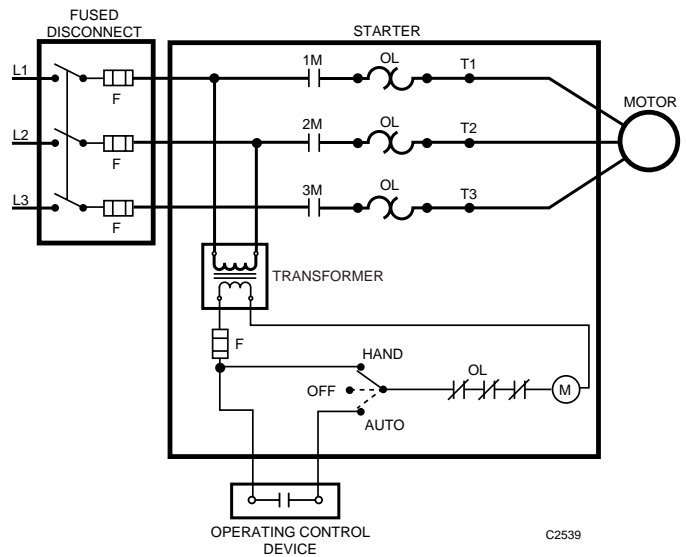

Fig. 36. Hand-Off-Auto Start-Stop Circuit.

MOMENTARY FAST-SLOW-OFF START-STOP CIRCUIT

Figure 37 illustrates a momentary, two-speed, start-stop circuit with separate windings for fast and slow motor speeds. Pressing the FAST button closes a circuit energizing starter solenoid F for the fast windings. Pressing the SLOW button closes a circuit energizing starter solenoid S for the slow windings. The holding circuits and the push-button contacts are mechanically interlocked to prevent energizing both sets of

windings at the same time. Pressing the STOP button opens both holding circuits and stops the motor.

Where a mechanical interlock does not exist between the holding circuits and push-button contacts, the fast speed start circuit must be opened before energizing the slow speed circuit because of the N.C. slow auxiliary contact wired in series with the fast speed solenoid. A similar situation exists when changing from slow to fast.

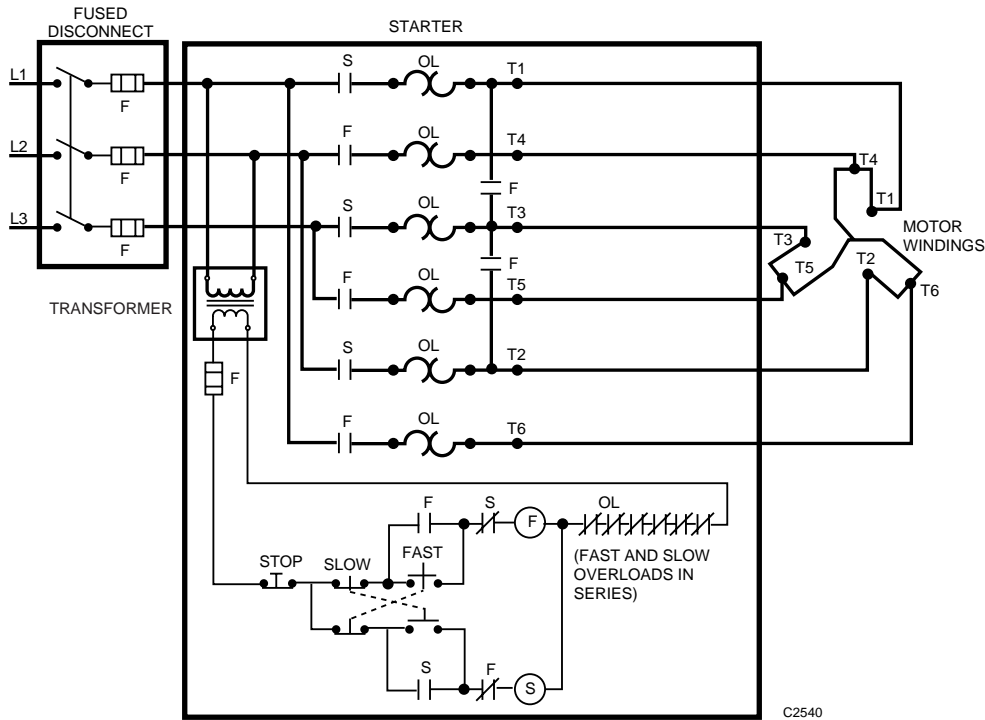
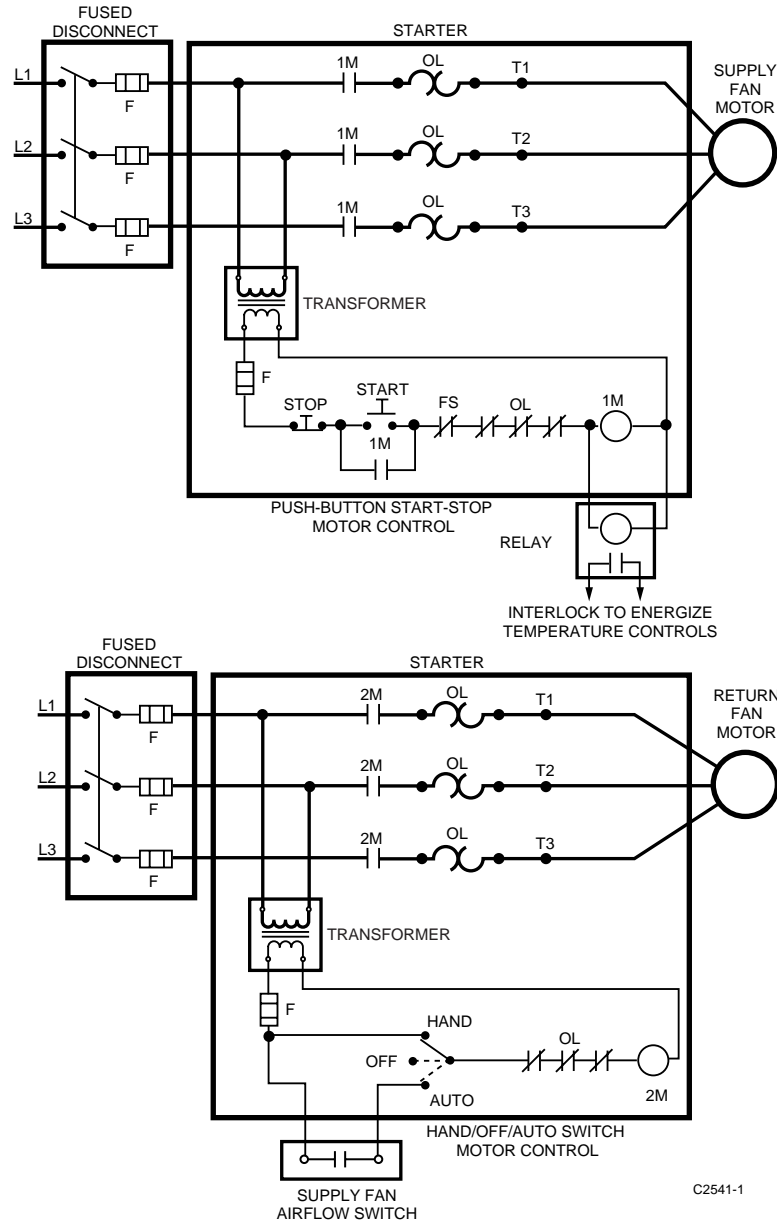

Fig. 37. Momentary Fast-Slow-Off Start-Stop Circuit.

CONTROL COMBINATIONS

There are many different control combinations for motor control circuits. Figure 38 illustrates a return fan interlocked with the supply fan. In this circuit, the supply fan starts when the START button is pressed energizing starter solenoid 1M.

The return fan will not start until supply airflow is proven. A relay can be added to interlock to the temperature control system. An auxiliary contact on the supply fan starter, when available, can be used for this same function.



C2541-1

Fig. 38. Typical Interlock of Supply and Return Fans.

Electronic Control Fundamentals

ENGINEERING MANUAL OF AUTOMATIC CONTROL

		CONTENTS
Introduction	120
Definitions	120
Typical System	122
Components	122
Sensors	122
Temperature Sensors	122
Resistance Temperature Devices	122
Solid-State Resistance Temperature Devices	124
Thermocouples	125
Transmitter/Transducer	125
Relative Humidity Sensor	125
Resistance Relative Humidity Sensor	125
Capacitance Relative Humidity Sensor	125
Temperature Compensation	126
Condensation and Wetting	126
Quartz Crystal Relative Humidity Sensor	126
Pressure Sensors	127
Controller	127
Input Types	127
Temperature Controllers	128
Relative Humidity Controllers	128
Enthalpy Controllers	128
Universal Controllers	128
Control Modes	128
Output Control	128
Output Devices	128
Two-Position	128
Modulating	128
Transducer	129
Indicating Device	129
Interface with Other Systems	129
Electronic Controller Fundamentals	129
General	129
Power Supply Circuit	129
Typical System Application	130

INTRODUCTION

This section provides information about electronic control systems used to control HVAC equipment. An electronic control system comprises a sensor, controller, and final control element. The sensors used in electronic control systems are simple, low-mass devices that provide stable, wide range, linear, and fast response. The electronic controller is a solid-state device that provides control over a discrete portion of the sensor range and generates an amplified correction signal to control the final control element. Electronic controllers provide two-position, proportional, or proportional plus integral (PI) control.

Features of electronic control systems include:

- Controllers can be remotely located from sensors and actuators.
- Controllers can accept a variety of inputs.
- Remote adjustments for multiple controls can be located together, even though sensors and actuators are not.
- Electronic control systems can accommodate complex control and override schemes.
- Universal type outputs can interface to many different actuators.
- Display meters indicate input or output values.

The sensors and output devices (e.g., actuators, relays) used for electronic control systems are usually the same ones used

on microprocessor-based systems. The distinction between electronic control systems and microprocessor-based systems is in the handling of the input signals. In an electronic control system, the analog sensor signal is amplified, then compared to a setpoint or override signal through voltage or current comparison and control circuits. In a microprocessor-based system, the sensor input is converted to a digital form, where discrete instructions (algorithms) perform the process of comparison and control.

Electronic control systems usually have the following characteristics:

Controller: Low voltage, solid state.

Inputs: 0 to 1V dc, 0 to 10V dc, 4 to 20 mA, resistance element, thermistor, thermocouple.

Outputs: 2 to 10V dc or 4 to 20 mA device.

Control Mode: Two-position, proportional, proportional plus integral (PI), step.

Circuits in this section are general. A resistance-temperature input and a 2 to 10V dc output are used for purposes of discussion. Electric circuits are defined in Electric Control Fundamentals. A detailed discussion on control modes can be found in the Control Fundamentals section.

DEFINITIONS

NOTE: For definitions of terms not in this section, see the Control Fundamentals section.

Authority (Compensation Authority or Reset Authority): A setting that indicates the relative effect a compensation sensor input has on the main setpoint (expressed in percent).

Compensation changeover: The point at which the compensation effect is reversed in action and changes from summer to winter or vice versa. The percent of compensation effect (authority) may also be changed at the same time.

Compensation control: A process of automatically adjusting the control point of a given controller to compensate for changes in a second measured variable such as outdoor air temperature. For example, the hot deck control point is reset upward as the outdoor air temperature decreases. Also known as “reset control”.

Compensation sensor: The system element which senses a variable other than the controlled variable and resets the main sensor control point. The amount of this effect is established by the authority setting.

Control Point: The actual value of a controlled variable (setpoint plus or minus offset).

Deviation: The difference between the setpoint and the value of the controlled variable at any moment. Also called offset.

Direct acting: A direct acting controller increases its output signal on an increase in input signal.

Electric control: A control circuit that operates on line or low voltage and uses a mechanical means, such as a temperature-sensitive bimetal or bellows, to perform control functions, such as actuating a switch or positioning a potentiometer. The controller signal usually operates or positions an electric actuator, although relays and switches are often included in the circuit.

Electronic control: A control circuit that operates on low voltage and uses solid-state components to amplify input signals and perform control functions, such as operating a relay or providing an output signal to position an actuator. Electronic devices are primarily used as sensors. The controller usually furnishes fixed control routines based on the logic of the solid-state components.

Electronic controller: A solid-state device usually consisting of a power supply, a sensor amplification circuit, a process/comparing circuit, an output driver section, and various components that sense changes in the controlled variable and derive a control output which provides a specific control function. In general, adjustments such as setpoint and throttling range necessary for the process can be done at the controller via potentiometers and/or switches.

Final control element: A device such as a valve or damper that changes the value of the manipulated variable. The final control element is positioned by an actuator.

Integral action (I): An action in which there is a continuous linear relationship between the amount of increase (or decrease) on the output to the final control element and the deviation of the controlled variable to reduce or eliminate the deviation or offset.

Limit sensor: A device which senses a variable that may be other than the controlled variable and overrides the main sensor at a preset limit.

Main sensor: A device or component that measures the variable to be controlled.

Negative (reverse) compensation: A compensating action where a decrease in the compensation variable has the same effect as an increase in the controlled variable. For example, in a heating application as the outdoor air temperature decreases, the control point of the controlled variable increases. Also called “winter compensation or reset”.

Offset: A sustained deviation between the control point and the setpoint of a proportional control system under stable operating conditions. Also called Deviation.

Positive (direct) compensation: A compensating action where an increase in the compensation variable has the same effect as an increase in the controlled variable. For example, in a cooling application as the outdoor air temperature increases, the control point of the controlled variable increases. Also called “summer compensation or reset”.

Proportional band (throttling range): In a proportional controller, the control point range through which the controlled variable must pass to drive the final control element through its full operating range. Proportional band is expressed in percent of the main sensor span. A commonly used equivalent is “throttling range” which is expressed in values of the controlled variable.

Proportional control (P): A control algorithm or method in which the final control element moves to a position proportional to the deviation of the value of the controlled variable from the setpoint.

Proportional-integral (PI) control: A control algorithm that combines the proportional (proportional response) and integral or deviation control algorithms. Integral action tends to correct the offset resulting from proportional control. Also called “proportional plus reset” or “two-mode” control.

Remote setpoint: A means for adjusting the controller setpoint from a remote location, in lieu of adjusting it at the controller itself. The means of adjustment may be manual with a panel or space mounted potentiometer, or automatic when a separate device provides a signal (voltage or resistive) to the controller.

Reset control: See Compensation Control.

Reset sensor: See Compensation Sensor.

Reverse acting: A reverse acting controller decreases its output signal on an increase in input signal.

Setpoint: The value on the controller scale at which the controller is set such as the desired room temperature set on a thermostat. The setpoint is always referenced to the main sensor (not the reset sensor).

Throttling range: In a proportional controller, the control point range through which the controlled variable must pass to move the final control element through its full operating range. Throttling range is expressed in values of the controlled variable such as temperature in kelvins, relative humidity in percent, or pressure in pascals or kilopascals. A commonly used equivalent is “proportional band” which is expressed in percent of sensor or transmitter span.

Transducer: A device that converts one energy form to another. It amplifies (or reduces) a signal so that the output of a sensor or transducer is usable as an input to a controller or actuator. A transducer can convert a pneumatic signal to an electric signal (P/E transducer) or vice versa (E/P transducer), or it can convert a change in capacitance to an electrical signal.

Transmitter: A device that converts a sensor signal to an input signal usable by a controller or display device. See also Transducer.

TYPICAL SYSTEM

Figure 1 shows a simple electronic control system with a controller that regulates supply water temperature by mixing return water with water from the boiler. The main temperature sensor is located in the hot water supply from the valve. To increase efficiency and energy savings, the controller resets the supply water temperature setpoint as a function of the outdoor air temperature. The controller analyzes the sensor data and sends a signal to the valve actuator to regulate the mixture of hot water to the unit heaters. These components are described in COMPONENTS.

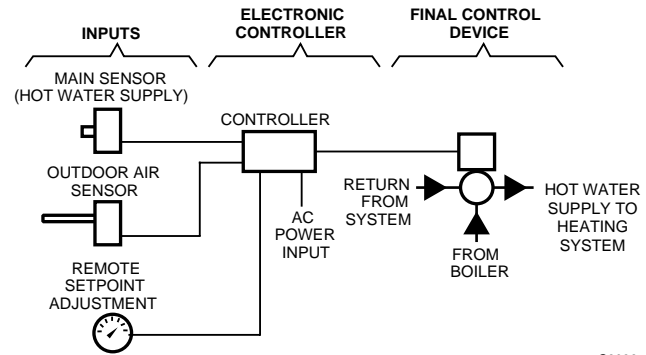

C3096

Fig. 1. Basic Electronic Control System.

COMPONENTS

An electronic control system includes sensors, controllers, output devices such as actuators and relays, final control elements such as valves and dampers, and indicating, interfacing, and accessory devices. Figure 2 provides a system overview for many electronic system components.

SENSORS

A sensing element provides a controller with information concerning changing conditions. Analog sensors are used to monitor continuously changing conditions such as temperature or pressure. The analog sensor provides the controller with a varying signal such as 0 to 10V. A digital (two-position) sensor is used if the conditions represent a fixed state such as a pump that is on or off. The digital sensor provides the controller with a discrete signal such as open or closed contacts.

Some electronic sensors use an inherent attribute of their material (e.g., wire resistance) to provide a signal and can be directly connected to the electronic controller. Other sensors require conversion of the sensor signal to a type or level that can be used by the electronic controller. For example, a sensor that detects pressure requires a transducer or transmitter to convert the pressure signal to a voltage or current signal usable by the electronic controller. Typical sensors used in electronic control systems are included in Figure 2. A sensor-transducer assembly is called a transmitter.

TEMPERATURE SENSORS

For electronic control, temperature sensors are classified as follows:

- Resistance Temperature Devices (RTDs) change resistance with varying temperature. RTDs have a positive temperature coefficient (resistance increases with temperature).
- Thermistors are solid-state resistance-temperature sensors with a negative temperature coefficient.
- Thermocouples directly generate a voltage as a function of temperature.

Resistance Temperature Devices

In general, all RTDs have some common attributes and limitations:

- The resistance of RTD elements varies as a function of temperature. Some elements exhibit large resistance changes, linear changes, or both over wide temperature ranges.
- The controller must provide some power to the sensor and measure the varying voltage across the element to determine the resistance of the sensor. This action can cause the element to heat slightly (called self-heating) and can create an inaccuracy in the temperature measurement. By reducing the supply current or by using elements with higher nominal resistances the self-heating effect can be minimized.

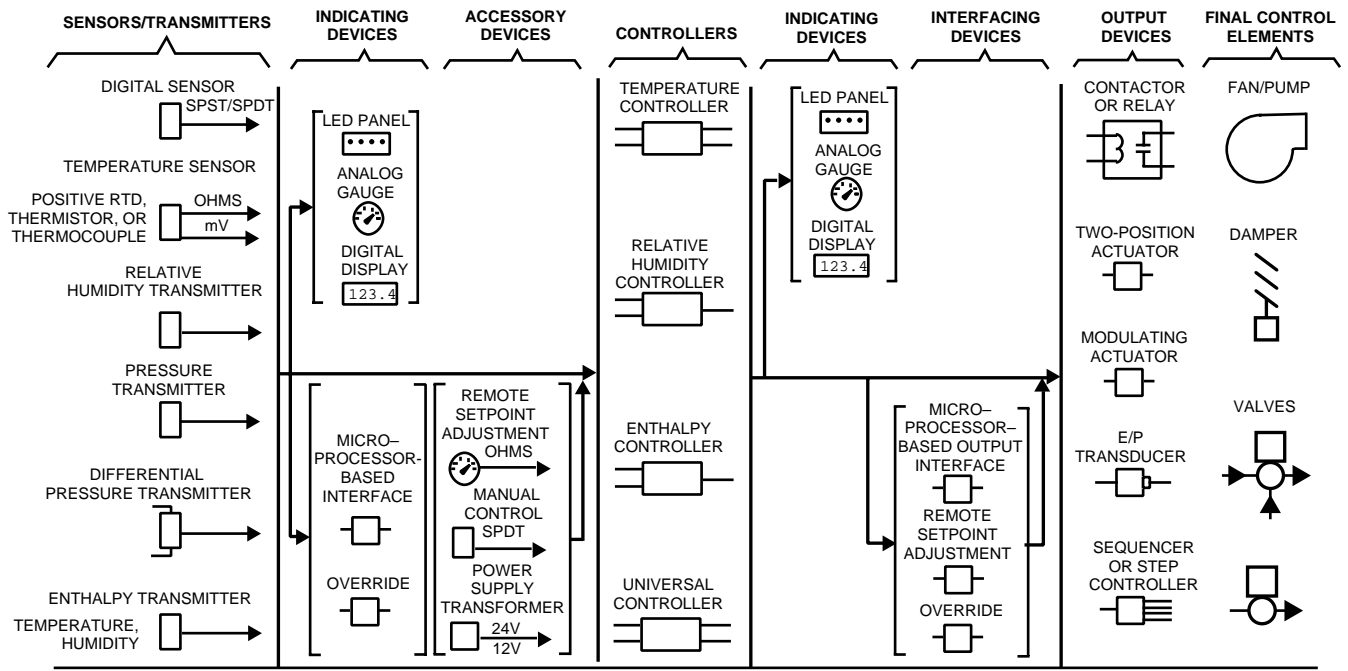

Fig. 2. Typical Electronic Control System Components.

- Some RTD element resistances are as low as 100 ohms. In these cases, the resistance of the lead wires connecting the RTD to the controller may add significantly to the total resistance of the connected RTD, and can create an error in the measurement of the temperature. Figure 3 shows a sensor and controller in relation to wire lead lengths. In this figure, a sensor 8 meters from the controller requires 16 meters of wire. If a solid copper wire with a dc resistance of 20.96 ohms per km is used, the 16 meters of wire has a total dc resistance of 0.335 ohms. If the sensor is a 100-ohm platinum sensor with a temperature coefficient of 1.24 ohms per kelvin, the 16 meters of wire will introduce an error of 0.27 degrees C. If the sensor is a 3000-ohm platinum sensor with a temperature coefficient of 8.6 ohms per kelvin, the 16 meters of wire will introduce an error of 0.039 degrees C.

Significant errors can be removed by adjusting a calibration setting on the controller, or, if the controller is designed for it, a third wire can be run to the sensor and connected to a special compensating circuit designed to remove the lead length effect on the measurement. In early electronic controllers, this three-wire circuit was connected to a Wheatstone Bridge configured for lead wire compensation. In digital controllers, lead wire compensation on low resistance sensors may be handled by software offset.

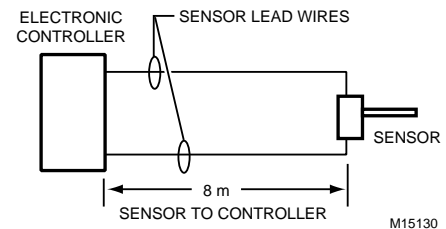

Fig. 3. Lead Wire Length.

- The usable temperature range for a given RTD sensor may be limited by nonlinearity at very high or low temperatures.
- RTD elements that provide large resistance changes per degree of temperature reduce the sensitivity and complexity of any electronic input circuit. (Linearity may be a concern, however.)

A sensor constructed using a BALCO wire; is a commonly used RTD sensor. BALCO is an annealed resistance alloy with a nominal composition of 70 percent nickel and 30 percent iron. A BALCO 500-ohm resistance element provides a relatively linear resistance variation from -40 to 120°C. The sensor is a low-mass device and responds quickly to changes in temperature.

Another material used in RTD sensors is platinum. It is linear in response and stable over time. In some applications a short length of wire is used to provide a nominal resistance of 100 ohms. However, with a low resistance value, the temperature indication can be effected by element self heating and sensor leadwire resistance. Additionally, due to the small amount of resistance change of the element, additional amplification must be used to increase the signal level.

To use the desirable characteristics of platinum and minimize any offset, one manufacturing technique deposits a film of platinum in a ladder pattern on an insulating base. A laser trimming method (Fig. 4) then burns away a portion of the metal to calibrate the sensor, providing a resistance of 1000 ohms at 23°C. This platinum film sensor provides a high resistance-to-temperature relationship. With its high resistance, the sensor is relatively immune to self-heating and sensor leadwire resistance offsets. In addition, the sensor is an extremely low-mass device and responds quickly to changes in temperature. RTD elements of this type are common. Early thin film platinum RTDs drifted due to their high surface-to-volume ratio which made them sensitive to contamination. Improved packaging and film isolation have eliminated these problems resulting in increased use of platinum RTDs over wire wound and NTC thermistors.

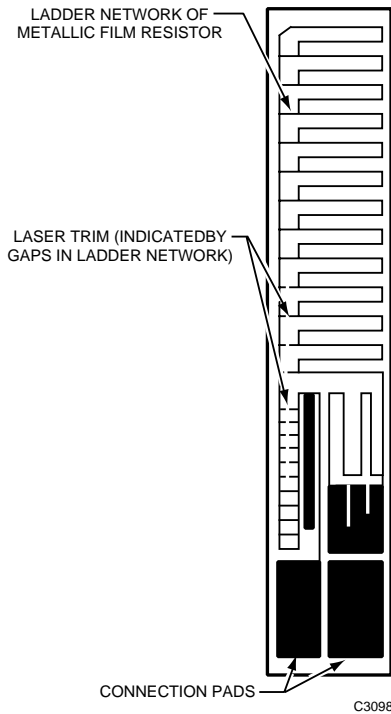

Fig. 4. Platinum Element RTD Sensor.

Solid-State Resistance Temperature Devices

Figure 5 shows examples of solid-state resistance temperature sensors having negative and positive temperature coefficients. Thermistors are negative temperature coefficient sensors typically enclosed in very small cases (similar to a glass diode

or small transistor) and provide quick response. As the temperature increases, the resistance of a thermistor decreases (Fig. 6). Selection of a thermistor sensor must consider the highly nonlinear temperature/resistance characteristic.

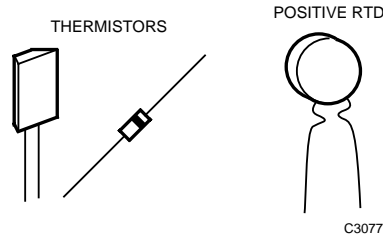

Fig. 5. Solid-State Temperature Sensors.

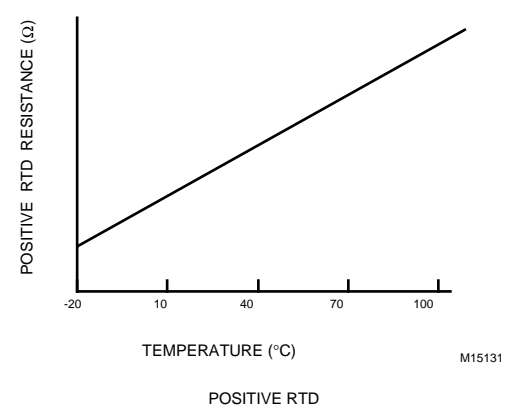
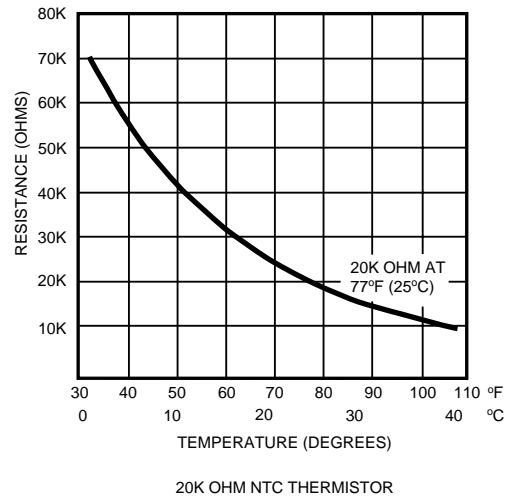

Fig. 6. Resistance vs Temperature Relationship for Solid-State Sensors.

Positive temperature coefficient solid-state temperature sensors may have relatively high resistance values at room temperature. As the temperature increases, the resistance of the sensor increases (Fig. 6). Some solid-state sensors have near perfect linear characteristics over their usable temperature range.

Thermocouples

A thermocouple, consists of two dissimilar metals, such as iron and constantan, welded together to form a two thermocouple junctions (Fig. 7). Temperature differences at the junctions causes a voltage, in the millivolt range, which can be measured by the input circuits of an electronic controller. By holding one junction at a known temperature (reference junction) and measuring the voltage, the temperature at the sensing junction can be deduced. The voltage generated is directly proportional to the temperature difference (Fig. 8). At room temperatures for typical HVAC applications, these voltage levels are often too small to be used, but are more usable at higher temperatures of 100 to 900°C. Consequently, thermocouples are most common in high-temperature process applications.

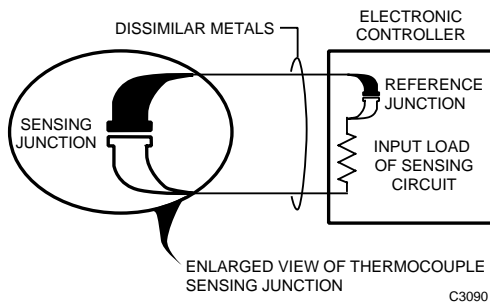

Fig. 7. Basic Thermocouple Circuit.

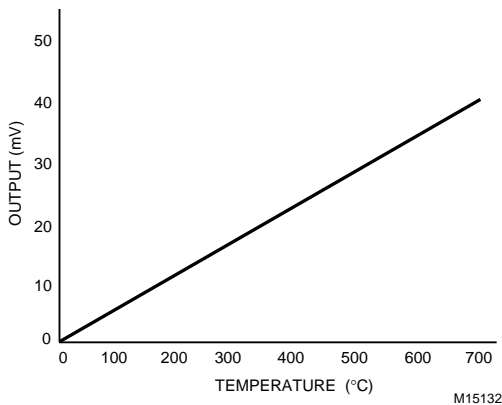

Fig. 8. Voltage vs Temperature for Iron-Constantan Thermocouple.

Transmitter/Transducer

The input circuits for many electronic controllers can accept a voltage range of 0 to 10V dc or a current range of 4 to 20 mA. The inputs to these controllers are classified as universal inputs because they accept any sensor having the correct output. These sensors are often referred to as transmitters as their outputs are an amplified or conditioned signal. The primary requirement of these transmitters is that they produce the required voltage or current level for an input to a controller over the desired sensing range.

Transmitters measure various conditions such as temperature, relative humidity, airflow, water flow, power consumption, air velocity, and light intensity. An example of a transmitter would be a sensor that measures the level of carbon dioxide (CO₂) in the return air of an air handling unit. The sensor provides a 4 to 20 mA signal to a controller input which can then modulate outdoor/exhaust dampers to maintain acceptable air quality levels. Since electronic controllers are capable of handling voltage, amperage, or resistance inputs, temperature transmitters are not usually used as controller inputs within the ranges of HVAC systems due to their high cost and added complexity.

RELATIVE HUMIDITY SENSOR

Various sensing methods are used to determine the percentage of relative humidity, including the measurement of changes of resistance, capacitance, impedance, and frequency.

Resistance Relative Humidity Sensor

An older method that used resistance to determine relative humidity depended on a layer of hygroscopic salt, such as lithium chloride or carbon powder, deposited between two electrodes (Fig. 9). Both materials absorb and release moisture as a function of the relative humidity, causing a change in resistance of the sensor. An electronic controller connected to this sensor detects the changes in resistance which it can use to provide control of relative humidity.

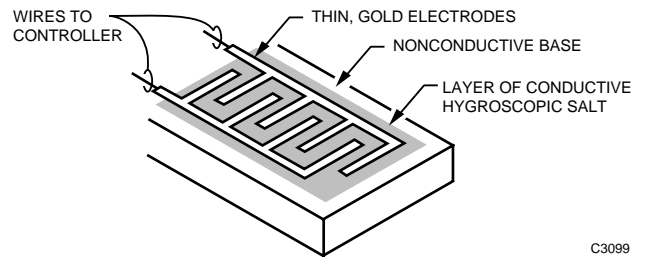
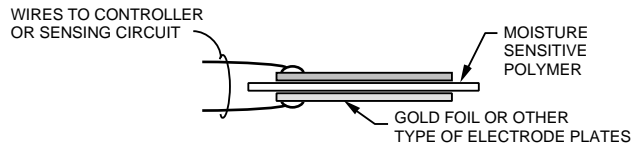

Fig. 9. Resistive Type Relative Humidity Sensor.

Capacitance Relative Humidity Sensor

A method that uses changes in capacitance to determine relative humidity measures the capacitance between two conductive plates separated by a moisture sensitive material such as polymer plastic (Fig. 10A). As the material absorbs water, the capacitance between the plates decreases and the change can be detected by an electronic circuit. To overcome any hindrance of the material's ability to absorb and release moisture, the two plates and their electric leadwires can be on one side of the polymer plastic and a third sheet of extremely thin conductive material on the other side of the polymer plastic form the capacitor (Fig. 10B). This third plate, too thin for attachment of leadwires, allows moisture to penetrate and be absorbed by the polymer thus increasing sensitivity and response.



A. MOISTURE SENSITIVE MATERIAL BETWEEN ELECTRODE PLATES.

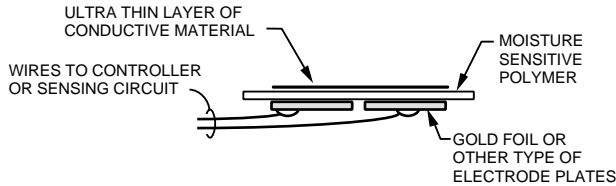

B. MOISTURE SENSITIVE MATERIAL BETWEEN ELECTRODE PLATES AND THIRD CONDUCTIVE PLATE.

C3100

Fig. 10. Capacitance Type Relative Humidity Sensor.

A relative humidity sensor that generates changes in both resistance and capacitance to measure moisture level is constructed by anodizing an aluminum strip and then applying a thin layer of gold or aluminum (Fig. 11). The anodized aluminum has a layer of porous oxide on its surface. Moisture can penetrate through the gold layer and fill the pores of the oxide coating causing changes in both resistance and capacitance which can be measured by an electronic circuit.

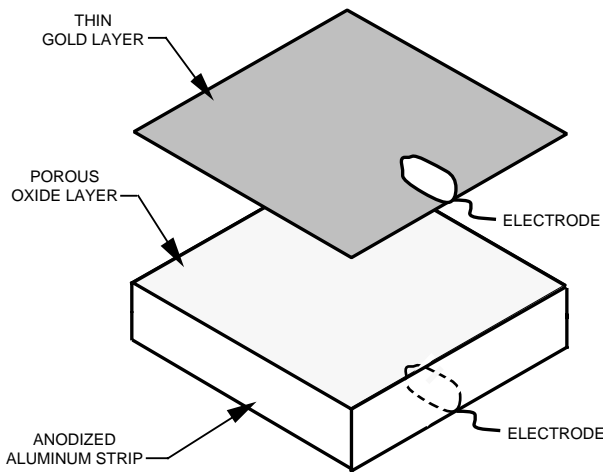

C3101

Fig. 11. Impedance Type Relative Humidity Sensor.

TEMPERATURE COMPENSATION

Both temperature and percent rh effect the output of all absorption based humidity sensors. Applications calling for either high accuracy or wide temperature operating range require temperature compensation. The temperature should be made as close as possible to the rh sensors active area. This is especially true when using rh and temperature to measure dewpoint. Figure 12 shows an rh sensor with the temperature sensor mounted directly on the substrate.

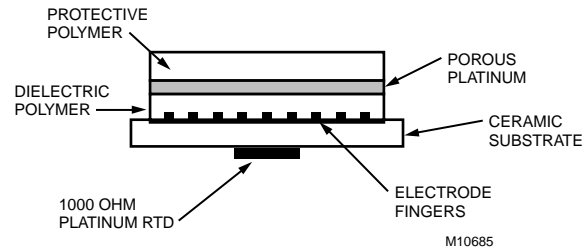

M10685

Fig. 12. Capacitance Type RH Sensor with Integral Temperature Compensation Sensor.

CONDENSATION AND WETTING

Condensation occurs whenever the sensors surface temperature drops below the dew point of the surrounding air, even if only momentarily. When operating at levels of 95% rh and above small temperature changes can cause condensation. Under these conditions where the ambient temperature and the dew point are very close, condensation forms quickly, but the moisture takes a long time to evaporate. Until the moisture is gone the sensor outputs a 100% rh signal.

When operating in high rh (90% and above), consider these strategies:

1. Maintain good air mixing to minimize local temperature fluctuations.
2. Use a sintered stainless steel filter to protect the sensor from splashing. A hydrophobic coating can also suppress condensation and wetting in rapidly saturating/desaturating or splash prone environment.
3. Heat the rh sensor above the ambient dew point temperature.

NOTE: Heating the sensor changes the calibration and makes it sensitive to thermal disturbances such as airflow.

Quartz Crystal Relative Humidity Sensor

Sensors that use changes in frequency to measure relative humidity (Fig. 13) can use a quartz crystal coated with a hygroscopic material such as polymer plastic. When the quartz crystal is energized by an oscillating circuit, it generates a constant frequency. As the polymer material absorbs moisture and changes the mass of the quartz crystal, the frequency of oscillation varies and can be measured by an electronic circuit.

Most relative humidity sensors require electronics at the sensor to modify and amplify the weak signal and are referred to as transmitters. The electronic circuit compensates for the effects of temperature as well as amplifies and linearizes the measured level of relative humidity. The transmitters typically provides a voltage or current output that can be used as an input to the electronic controller.

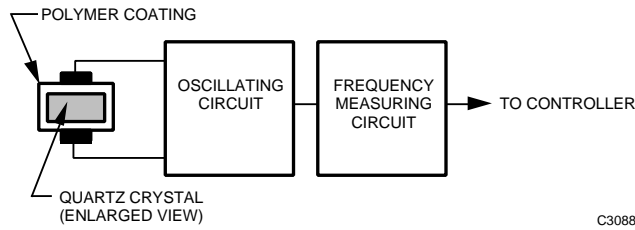

Fig. 13. Quartz Crystal Relative Humidity Sensor.

PRESSURE SENSORS

An electronic pressure sensor converts pressure changes into a signal such as voltage, current, or resistance that can be used by an electronic controller.

A method that measures pressure by detecting changes in resistance uses a small flexible diaphragm and a strain gage assembly (Fig. 13). The strain gage assembly includes very fine (serpentine) wire or a thin metallic film deposited on a nonconductive base. The strain gage assembly is stretched or compressed as the diaphragm flexes with pressure variations. The stretching or compressing of the strain gage (shown by dotted line in Fig. 14) changes the length of its fine wire/thin film metal, which changes the total resistance. The resistance can then be detected and amplified. These changes in resistance are small. Therefore, an amplifier is provided in the sensor assembly to amplify and condition the signal so the level sent to the controller is less susceptible to external noise interference. The sensor thus becomes a transmitter.

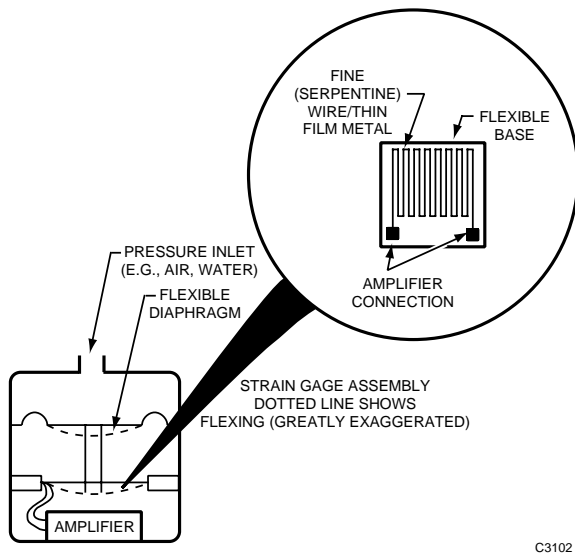

Fig. 14. Resistance Type Pressure Sensor.

Another pressure sensing method measures capacitance (Fig. 15). A fixed plate forms one part of the capacitor assembly and a flexible plate is the other part of the capacitor assembly. As the diaphragm flexes with pressure variations, the flexible plate of the capacitor assembly moves closer to the fixed plate (shown by dotted line in Fig. 14) and changes the capacitance.

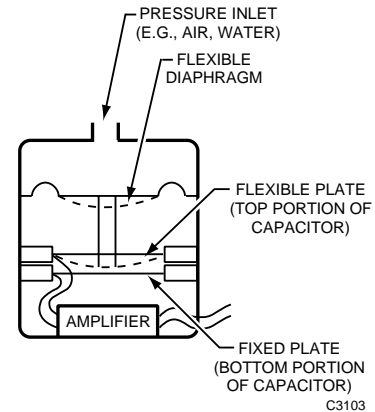

Fig. 15. Capacitance Type Pressure Transmitters.

A variation of pressure sensors is one that measures differential pressure using dual pressure chambers (Fig. 16). The force from each chamber acts in an opposite direction with respect to the strain gage. This type of sensor can measure small differential pressure changes even with high static pressure.

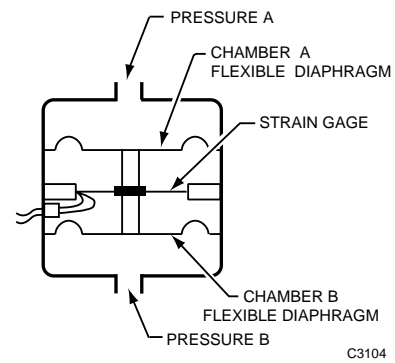

Fig. 16. Differential Pressure Sensor.

CONTROLLER

The electronic controller receives a sensor signal, amplifies and/or conditions it, compares it with the setpoint, and derives a correction if necessary. The output signal typically positions an actuator. Electronic controller circuits allow a wide variety of control functions and sequences from very simple to multiple input circuits with several sequential outputs. Controller circuits use solid-state components such as transistors, diodes, and integrated circuits and include the power supply and all the adjustments required for proper control.

INPUT TYPES

Electronic controllers are categorized by the type or types of inputs they accept such as temperature, humidity, enthalpy, or universal.

Temperature Controllers

Temperature controllers typically require a specific type or category of input sensors. Some have input circuits to accept RTD sensors such as BALCO or platinum elements, while others contain input circuits for thermistor sensors. These controllers have setpoint and throttling range scales labeled in degrees F or C.

Relative Humidity Controllers

The input circuits for relative humidity controllers typically receive the sensed relative humidity signal already converted to a 0 to 10V dc voltage or 4 to 20 mA current signal. Setpoint and scales for these controllers are in percent relative humidity.

Enthalpy Controllers

Enthalpy controllers are specialized devices that use specific sensors for inputs. In some cases, the sensor may combine temperature and humidity measurements and convert them to a single voltage to represent enthalpy of the sensed air. In other cases, individual dry bulb temperature sensors and separate wet bulb or relative humidity sensors provide inputs and the controller calculates enthalpy. In typical applications, the enthalpy controller provides an output signal based on a comparison of two enthalpy measurements, indoor and outdoor, rather than on the actual enthalpy value. In other cases, the return air enthalpy is assumed constant so that only outdoor air enthalpy is measured. It is compared against the assumed nominal return air value.

Universal Controllers

The input circuits of universal controllers can accept one or more of the standard transmitter/transducer signals. The most common input ranges are 0 to 10V dc and 4 to 20 mA. Other input variations in this category include a 2 to 10V dc and a 0 to 20 mA signal. Because these inputs can represent a variety of sensed variables such as a current of 0 to 15 amperes or pressure of 0 to 21000 kPa, the settings and scales are often expressed in percent of full scale only.

CONTROL MODES

The control modes of some electronic controllers can be selected to suit the application requirements. Control modes include two-position, proportional, and proportional-integral. Other control features include remote setpoint, the addition of a compensation sensor for reset capability, and override or limit control.

OUTPUT CONTROL

Electronic controllers provide outputs to a relay or actuator for the final control element. The output is not dependent on the input types or control method. The simplest form of output is two-position where the final control element can be in one of two states. For example, an exhaust fan in a mechanical room can be turned either on or off. The most common output form, however, provides a modulating output signal which can adjust the final control device (actuator) between 0 and 100 percent such as in the control of a chilled water valve.

OUTPUT DEVICES

Actuator, relay, and transducer (Fig. 2) are output devices which use the controller output signal (voltage, current, or relay contact) to perform a physical function on the final control element such as starting a fan or modulating a valve. Actuators can be divided into devices that provide two-position action and those that provide modulating action.

TWO-POSITION

Two-position devices such as relays, motor starters, and solenoid valves have only two discrete states. These devices interface between the controller and the final control element. For example, when a solenoid valve is energized, it allows steam to enter a coil which heats a room (Fig. 17). The solenoid valve provides the final action on the controlled media, steam. Damper actuators can also be designed to be two-position devices.

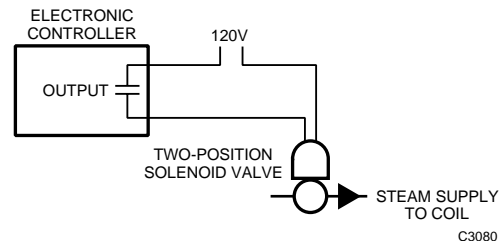

Fig. 17. Two-Position Control.

MODULATING

Modulating actuators use a varying control signal to adjust the final control element. For example, a modulating valve controls the amount of chilled water entering a coil so that cool supply air is just sufficient to match the load at a desired setpoint (Fig. 18). The most common modulating actuators accept a varying voltage input of 0 to 10 or 2 to 10V dc or a current input of 4 to 20 mA. Another form of actuator requires a pulsating (intermittent) or duty cycling signal to perform modulating functions. One form of pulsating signal is a Pulse Width Modulation (PWM) signal.

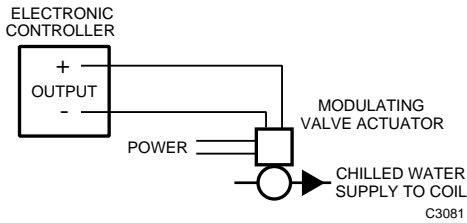

Fig. 18. Modulating Control.

TRANSDUCER

In some applications, a transducer converts a controller output to a signal that is usable by the actuator. For example, Figure 19 shows an Electronic-to-Pneumatic (E/P) transducer: electronic-to-pneumatic that converts a modulating 2 to 10V dc signal from the electronic controller to a pneumatic proportional modulating 20 to 90 kPa signal for a pneumatic actuator.

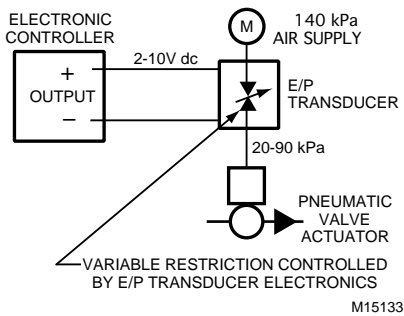

Fig. 19. Electric-to-Pneumatic Transducer.

ELECTRONIC CONTROLLER FUNDAMENTALS

GENERAL

The electronic controller is the basis for an electronic control system. Figure 21 shows the basic circuits of an electronic controller including power supply, input, control, and output. For greater stability and control, internal feedback correction circuits also can be included, but are not discussed. The circuits described provide an overview of the types and methods of electronic controllers.

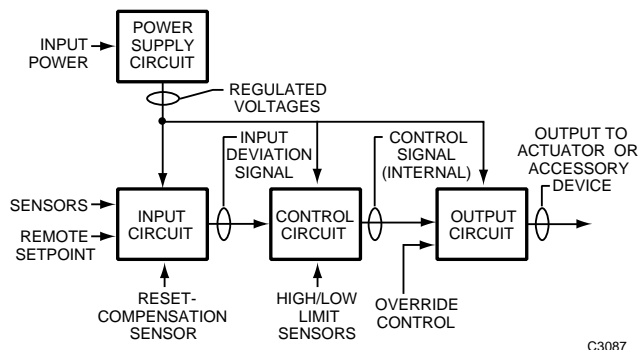

Fig. 21. Electronic Controller Circuits.

INDICATING DEVICE

An electronic control system can be enhanced with visual displays that show system status and operation. Many electronic controllers have built-in indicators that show power, input signal, deviation signal, and output signal. Figure 20 shows some types of visual displays. An indicator light can show on/off status or, if driven by controller circuits, the brightness of a light can show the relative strength of a signal. If a system requires an analog or digital indicating device and the electronic controller does not include this type of display, separate indicating devices can be provided.

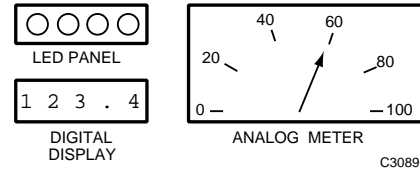

Fig. 20. Indicating Devices.

INTERFACE WITH OTHER SYSTEMS

It is often necessary to interface an electronic control device to a system such as a microprocessor-based building management system. An example is an interface that allows a building management system to adjust the setpoint or amount of reset (compensation) for a specific controller. Compatibility of the two systems must be verified before they are interconnected.

TYPICAL SYSTEM APPLICATION

Figure 22 shows a typical air handling system controlled by two electronic controllers, C1 and C2; sequencer S; multicomparator M; temperature sensors T1 through T4; modulating hot and chilled water valves V1 and V2; and outdoor, return, and exhaust air damper actuators. The control sequence is as follows:

- Controller C1 provides outdoor compensated, summer-winter control of space temperature for a heating/cooling system which requires PI control with a low limit. Sensor T4 provides the compensation signal through multicomparator M which allows one outdoor temperature sensor to provide a common input to several controllers. Controller C1 modulates the hot and chilled water valves V1 and V2 in sequence to maintain space temperature measured by sensor T1 at a preselected setpoint. Sequencer S allows sequencing the two valve actuators from a single controller. Low-limit sensor T2 assumes control when the discharge air temperature drops to the control range of the low limit setpoint. A minimum discharge air temperature is maintained regardless of space temperature.

When the outdoor temperature is below the selected reset changeover point set on C1, the controller is in the winter compensation mode. As the outdoor air temperature falls, the space temperature setpoint is raised. When the outdoor temperature is above the reset changeover point, the controller is in the summer compensation mode. As the outdoor temperature rises, the space temperature setpoint is raised.

- Controller C2 provides PI mixed air temperature control with economizer operation. When the outdoor temperature measured by sensor T4 is below the setting of the economizer startpoint setting, the controller provides proportional control of the dampers to maintain mixed air temperature measured by sensor T3 at the selected setpoint. When the outdoor air temperature is above the economizer startpoint setting, the controller closes the outdoor air dampers to a preset minimum.

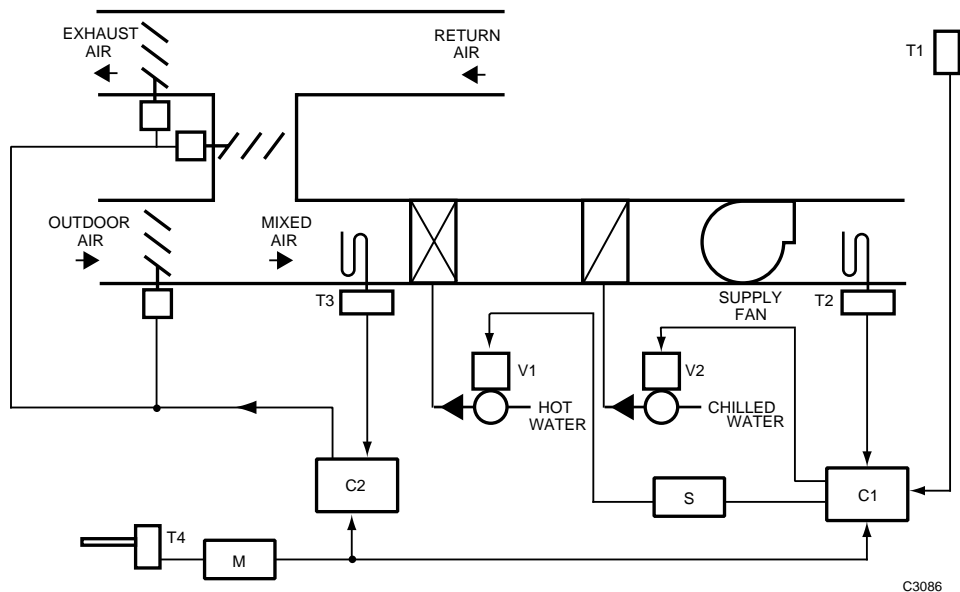

Fig. 22. Typical Application with Electronic Controllers.

Microprocessor-Based/DDC Fundamentals

ENGINEERING MANUAL OF AUTOMATIC CONTROL

		CONTENTS
Introduction	133
Definitions	133
Background	134
	Computer Based Control	134
	Direct Digital Control	134
Advantages	134
	Lower Cost Per Function	134
	Application Flexibility	134
	Coordinated Multifunction Capability	135
	Precise and Accurate Control	135
	Reliability	135
Controller Configuration	135
Types of Controllers	136
	Zone-Level Controllers	136
	System-Level Controller	136
Controller Software	137
	Operating Software	137
	Application Software	137
	Direct Digital Control Software	137
	Energy Management Software	138
	Optimum Start	138
	Optimum Stop	138
	Night Cycle	138
	Night Purge	139
	Enthalpy	139
	Load Reset	139
	Zero Energy Band	141
	Distributed Power Demand	142
	Building Management Software	142
Controller Programming	142
	General	142
	Programming Categories	143
	Configuration Programming	143
	System Initialization Programming	143
	Data File Programming	143
	Custom Control Programming	143
	Analyze Control Application	144
	Partition Into Control Loops	144
	Determine Inputs and Outputs	144
	Design, Write, and Compile Program	145
	Debug, Install, Enter Data Files, and Test	145

Typical Applications	145
Zone-Level Controller	145
Example 1. VAV Cooling Only	145
Example 2. VAV Cooling with Sequenced Electric Reheat.....	145
System-Level Controller	146

INTRODUCTION

This section discusses the types of microprocessor-based controllers used in commercial buildings. These controllers measure signals from sensors, perform control routines in software programs, and take corrective action in the form of output signals to actuators. Since the programs are in digital form, the controllers perform what is known as direct digital control (DDC). Microprocessor-based controllers can be used as stand-alone controllers or they can be used as controllers incorporated into a building management system utilizing a personal computer (PC) as a host to provide additional

functions. A stand-alone controller can take several forms. The simplest generally controls only one control loop while larger versions can control from eight to 40 control loops. As the systems get larger, they generally incorporate more programming features and functions. This section covers the controller as a stand-alone unit. Refer to the Building Management System Fundamentals section for additional information on use of the controller in networked and building management systems.

DEFINITIONS

Analog-to-digital (A/D) converter: The part of a microprocessor-based controller that changes an analog input signal to a digital value for use by the microprocessor in executing software programs. Analog input values typically come from temperature, pressure, humidity, or other types of sensors or transducers.

Application software: Programs that provide functions such as direct digital control, energy management, lighting control, event initiated operations, and other alarm and monitoring routines.

Configurable controller: A controller with a set of selectable programs with adjustable parameters but without the ability to modify the programs.

Digital-to-analog (D/A) converter: The part of a microprocessor-based controller that changes digital values from a software program to analog output signals for use in the control system. The analog signals are typically used to position actuators or actuate transducers and relays.

Direct digital control: A control loop in which a digital controller periodically updates a process as a function of a set of measured control variables and a given set of control algorithms.

Microprocessor-based controller: A device consisting of a microprocessor unit, digital input and output connections, A/D and D/A converters, a power supply, and software to perform direct digital control and energy management routines in a HVAC system.

Operating software: The main operating system and programs that schedule and control the execution of all other programs in a microprocessor-based controller. This includes routines for input/output (I/O) scanning, A/D and D/A conversion, scheduling of application programs, and access and display of control program variables.

System-level controller: A microprocessor-based controller that controls centrally located HVAC equipment such as variable air volume (VAV) supply units, built-up air handlers, and central chiller and boiler plants. These controllers typically have a library of control programs, may control more than one mechanical system from a single controller, and may contain an integral operating terminal.

Zone-level controller: A microprocessor-based controller that controls distributed or unitary HVAC equipment such as VAV terminal units, fan coil units, and heat pumps. These controllers typically have relatively few connected I/O devices, standard control sequences, and are dedicated to specific applications.

BACKGROUND

COMPUTER BASED CONTROL

Computer based control systems have been available as an alternative to conventional pneumatic and electronic systems since the mid 1960s. Early installations required a central mainframe or minicomputer as the digital processing unit. They were expensive, and application was limited to larger buildings. Reliability was also an issue since loss of the central computer meant loss of the entire control system. Advances in microtechnology, particularly in large scale integration (LSI), provided answers to both the cost and reliability issues. Introduction of microprocessors, i.e., a computer on a chip, and high-density memories reduced costs and package size dramatically and increased application flexibility (Fig. 1). Microprocessor programs include all the arithmetic, logic, and control elements of larger computers, thus providing computing power at a cost/performance ratio suitable for application to individual air handlers, heat pumps, VAV terminal units, or the entire equipment room. Microprocessor-based controllers allow digital control to be distributed at the zone level, equipment room level, or they can control an entire building.

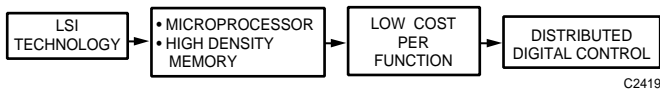

Fig. 1. Evolution of Distributed Digital Control.

DIRECT DIGITAL CONTROL

Inherent in microprocessor-based controllers is the ability to perform direct digital control. DDC is used in place of conventional pneumatic or electronic local control loops. There are several industry accepted definitions of DDC. DDC can be defined as “a control loop in which a digital controller periodically updates a process as a function of a set of measured control variables and a given set of control algorithms”.

ADVANTAGES

Digital control offers many advantages. Some of the more important advantages are discussed in the following.

LOWER COST PER FUNCTION

In general, microprocessor and memory costs keep coming down while inherent functionality keeps going up. Compared to earlier systems, physical size of the controller is also reduced while the number of discrete functions is increased. Digital control, using a microcomputer-based controller, allows more sophisticated and energy efficient control

A more detailed definition is provided in the ASHRAE 1995 HVAC Applications Handbook. “A digital controller can be either single- or multi-loop. Interface hardware allows the digital computer to process signals from various input devices, such as the electronic temperature, humidity, and pressure sensors described in the section on Sensors. Based on the digitized equivalents of the voltage or current signals produced by the inputs, the control software calculates the required state of the output devices, such as valve and damper actuators and fan starters. The output devices are then moved to the calculated position via interface hardware, which converts the digital signal from the computer to the analog voltage or current required to position the actuator or energize a relay.”

In each of these definitions the key element for DDC is digital computation. The microprocessor unit (MPU) in the controller provides the computation. Therefore, the term digital in DDC refers to digital processing of data and not that HVAC sensor inputs or control outputs from the controller are necessarily in digital format. Nearly all sensor inputs are analog and most output devices are also analog. In order to accept signals from these I/O devices, A/D and D/A converters are included in the microprocessor-based controller. Figure 2 shows several inputs and outputs. The microprocessor usually performs several control functions.

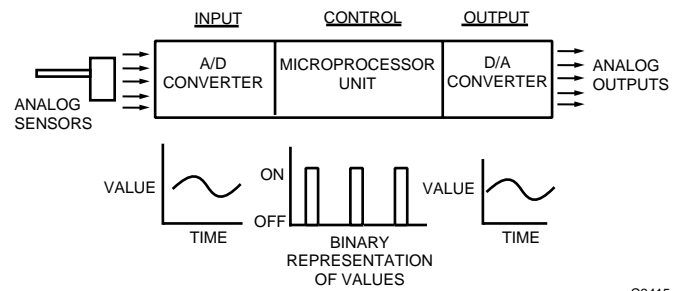

Fig. 2. Analog Functions of a Digital Controller.

sequences to be applied at a lower cost than with non-digital controls; however, simple applications might be less costly with non-digital controls.

APPLICATION FLEXIBILITY

Since microprocessor-based controllers are software based, application flexibility is an inherent feature. A wide variety of HVAC functions can be programmed and, in addition, the controller can perform energy management, indoor air quality

(IAQ), and/or building management functions. Changes in control sequences can easily be accommodated through software whether dictated by system performance or by changes in the owner's use of the facility.

COORDINATED MULTIFUNCTION CAPABILITY

Although basic environmental control and energy management operate as independent programs, it is best to have them incorporated as an integrated program in order to provide more efficient control sequences. For example, sensing the temperatures of several zones to determine the average demand, or the zone with the greatest demand for cooling, will provide improved efficiency and control over merely sampling a representative zone for a chiller reset program. An added feature is that the sensors providing zone comfort control can serve a dual function at no added cost. These benefits require controller-to-controller communications which is discussed in the Building Management System Fundamentals section.

CONTROLLER CONFIGURATION

The basic elements of a microprocessor-based (or micro-processor) controller (Fig. 3) include:

- The microprocessor
- A program memory
- A working memory
- A clock or timing devices
- A means of getting data in and out of the system

In addition, a communications port is not only a desirable feature but a requirement for program tuning or interfacing with a central computer or building management system.

Timing for microprocessor operation is provided by a battery-backed clock. The clock operates in the microsecond range controlling execution of program instructions.

Program memory holds the basic instruction set for controller operation as well as for the application programs. Memory size and type vary depending on the application and whether the controller is considered a dedicated purpose or general purpose device. Dedicated purpose configurable controllers normally have standard programs and are furnished with read only memory (ROM) or programmable read only memory (PROM.) General purpose controllers often accommodate a variety of individual custom programs and are supplied with field-alterable memories such as electrically erasable, programmable, read only memory (EEPROM) or flash memory. Memories used to hold the program for a controller must be nonvolatile, that is, they retain the program data during power outages.

PRECISE AND ACCURATE CONTROL

Proportional control has the inherent problem of offset. The wider the throttling range is set for control stability, the greater the offset. With the microprocessor-based controller, the offset can easily be corrected by the simple addition of integral action. For even more accurate control over a wide range of external conditions, adaptive control algorithms, available in some microprocessor-based controllers, can be employed. With adaptive control, system performance automatically adjusts as conditions vary. The need for manual fine tuning for seasonal changes is eliminated. These items are discussed in the Control Fundamentals section.

RELIABILITY

Digital controllers should be conservatively designed and should incorporate self-checking features so they notify the operator immediately if anything goes wrong. Input and output circuits should be filtered and protected from extraneous signals to assure reliable information to the processor.

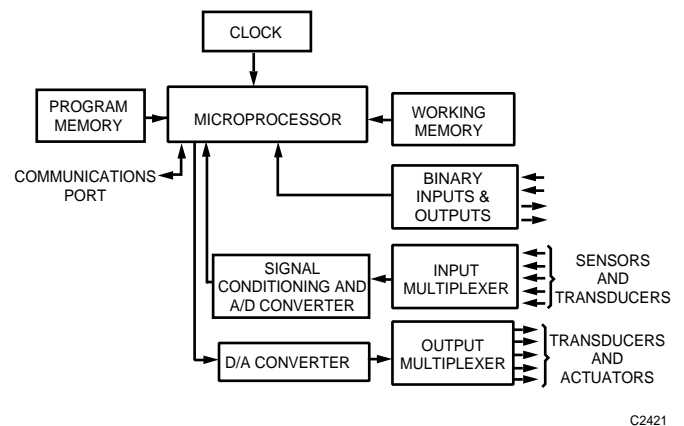

C2421

Fig. 3. Microprocessor Controller Configuration for Automatic Control Applications.

All input signals, whether analog or digital, undergo conditioning (Fig. 3) to eliminate the adverse affects of contact bounce, induced voltage, or electrical transients. Time delay circuits, electronic filters, and optical coupling are commonly used for this purpose. Analog inputs must also be linearized, scaled, and converted to digital values prior to entering the microprocessor unit. Resistance sensor inputs can also be compensated for leadwire resistance. For additional information about electronic sensors see the Electronic Control Fundamentals section.

Performance and reliability of temperature control applications can be enhanced by using a single 12-bit A/D converter for all controller multiplexed inputs, and simple two-wire high resistance RTDs as inputs.

A/D converters for DDC applications normally range from 8 to 12 bits depending on the application. An 8-bit A/D converter provides a resolution of one count in 256. A 12-bit A/D converter provides a resolution of one count in 4096. If the A/D converter is set up to provide a binary coded decimal (BCD) output, a 12-bit converter can provide values from 0 to 999, 0 to 99.9, or 0 to 9.99 depending on the decimal placement. This

range of outputs adequately covers normal control and display ranges for most HVAC control applications. D/A converters generally range from 6 to 10 bits.

The output multiplexer (Fig. 3) provides the reverse operation from the input multiplexer. It takes a serial string of output values from the D/A converter and routes them to the terminals connected to a transducer or a valve or damper actuator.

The communication port (Fig. 3) allows interconnection of controllers to each other, to a master controller, to a central computer, or to local or portable terminals.

TYPES OF CONTROLLERS

Microprocessor-based controllers operate at two levels in commercial buildings: the zone level and the system level. See Figure 4.

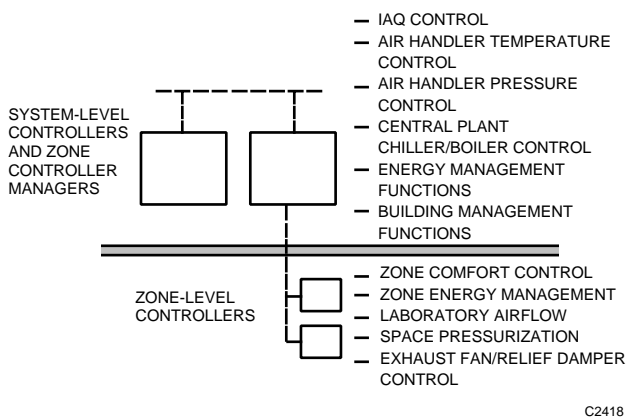

Fig. 4. Zone- and System-Level Controllers.

ZONE-LEVEL CONTROLLERS

Zone-level controllers typically control HVAC terminal units that supply heating and cooling energy to occupied spaces and other areas in the building. They can control VAV terminal units, fan coil units, unit ventilators, heat pumps, space pressurization equipment, laboratory fume hoods, and any other zone control or terminal unit device. Design of a zone-level controller is usually dictated by the specific requirements of the application. For example, the controller for a VAV box is frequently packaged with an integral damper actuator and has only the I/O capacity necessary to meet this specific application. On the other hand, a zone-level controller for a packaged heating/cooling unit might have the controller packaged in the thermostat housing (referred to as a smart thermostat or smart controller). Zone level control functions may also be accomplished with bus-connected intelligent sensors and actuators.

SYSTEM-LEVEL CONTROLLER

System-level controllers are more flexible than zone-level controllers in application and have more capacity. Typically, system-level controllers are applied to systems in equipment rooms including VAV central supply systems, built-up air handlers, and central chiller and boiler plants. Control sequences vary and usually contain customized programs written to handle the specific application requirements.

The number of inputs and outputs required for a system-level controller is usually not predictable. The application of the controller must allow both the number and mix of inputs and outputs to be variable. Several different packaging approaches have been used:

- Fixed I/O configuration.
- Universal I/O configuration.
- Card cage with plug-in function boards.
- Master/slave I/O modules.

Universal I/O allows software to define the function of each set of terminals.

Zone- and system-level controllers should be equipped with a communications port. This allows dynamic data, setpoints, and parameters to be passed between a local operator terminal, a central building management system, and/or other controllers. Data passed to other controllers allows sensor values to be shared and interaction between zone-level programs and system-level programs to be coordinated. For example, night setback and morning warmup can be implemented at the zone-level controller based on operational mode information received from the system-level controller.

CONTROLLER SOFTWARE

Although microprocessor-based controller hardware governs, to some extent, how a controller is applied, software determines the functionality. Controller software falls basically into two categories:

1. Operating software which controls the basic operation of the controller.
2. Application software which addresses the unique control requirements of specific applications.

OPERATING SOFTWARE

Operating software is normally stored in nonvolatile memory such as ROM or PROM and is often referred to as firmware. Operating software includes the operating system (OS) and routines for task scheduling, I/O scanning, priority interrupt processing, A/D and D/A conversion, and access and display of control program variables such as setpoints, temperature values, parameters, and data file information. Tasks are scheduled sequentially and interlaced with I/O scanning and other routine tasks in such a way as to make operation appear almost simultaneous. However, an external event such as an alarm or a request to execute an energy management program, can require that normal operations be suspended until the higher priority task is serviced. These requests are processed by priority interrupt software. The interrupt causes the current operation to cease, and all data held in registers and accumulators pertinent to the interrupted programs is temporarily stored in memory. Once the interrupt request is processed, all data is returned to the proper registers, and the program resumes where it left off. Multiple levels or prioritized interrupts are provided. The effect of these interrupts is transparent to the application that the controller is controlling.

APPLICATION SOFTWARE

Application software includes direct digital control, energy management, lighting control, and event initiated programs plus other alarm and monitoring software typically classified as building management functions. The system allows application programs to be used individually or in combination. For example, the same hardware and operating software can be used for a new or existing building control by using different programs to match the application. An existing building, for example, might require energy management software to be added to the existing control system. A new building, however, might require a combination of direct digital control and energy management software.

DIRECT DIGITAL CONTROL SOFTWARE

DDC software can be defined as a set of standard DDC operators and/or high-level language statements assembled to accomplish a specific control action. Key elements in most direct digital control programs are the PID and the enhanced EPID and ANPID algorithms. For further information, refer to the Control Fundamentals section.

While the P, PI, PID, EPID, and ANPID operators provide the basic control action, there are many other operators that enhance and extend the control program. Some other typical operators are shown in Table 1. These operators are computer statements that denote specific DDC operations to be performed in the controller. Math, time/calendar, and other calculation routines (such as calculating an enthalpy value from inputs of temperature and humidity) are also required.

Table 1. Typical DDC Operators.

Operator	Description
Sequence	Allows several controller outputs to be sequenced, each one operating over a full output range.
Reversing	Allows the control output to be reversed to accommodate the action of a control valve or damper actuator.
Ratio	Translates an analog output on one scale to a proportional analog output on a different scale.
Analog controlled digital output	Allows a digital output to change when an analog input reaches an assigned value. Also has an assignable dead band feature.
Digital controlled analog output	Functionally similar to a signal switching relay. One state of the digital input selects one analog input as its analog output; the other state selects a second analog input as the analog output.
Analog controlled analog output	Similar to the digital controlled analog output except that the value and direction of the analog input value selects one of the two analog signals for output.
Maximum input	Selects the highest of several analog input values as the analog output.
Minimum input	Selects the lowest of several analog input values as the analog output.
Delay	Provides a programmable time delay between execution of sections of program code.
Ramp	Converts fast analog step value changes into a gradual change.

The use of preprogrammed operators saves time when writing control sequences and makes understanding of the control sequence the equivalent of reading a pneumatic control diagram. Programming schemes often allow program operators to be selected, positioned, and connected graphically. The alternative to using preprogrammed operators is to write an equivalent control program using the programming language furnished for the controller.

ENERGY MANAGEMENT SOFTWARE

Microprocessor-based controllers can combine control and energy management functions in the controller to allow sensor and data file sharing and program coordination. Energy management functions can be developed via the above DDC operators, math functions, and time clock values, or they can be separate program subroutines.

A summary of energy management programs possible for integration into microprocessor-based controllers follows:

Optimum Start

Based on measurements of indoor and outdoor temperatures and a historical multiplier adjusted by startup data from the previous day, the optimum start program (Fig. 5) calculates a lead time to turn on heating or cooling equipment at the optimum time to bring temperatures to proper level at the time of occupancy. To achieve these results the constant volume AHU optimum start program delays AHU start as long as possible, while the VAV optimum start program often runs the VAV AHU at reduced capacity. Unless required by IAQ, outdoor air dampers and ventilation fans should be inactive during preoccupancy warmup periods. For weekend shutdown periods, the program automatically adjusts to provide longer lead times. This program adapts itself to seasonal and building changes.

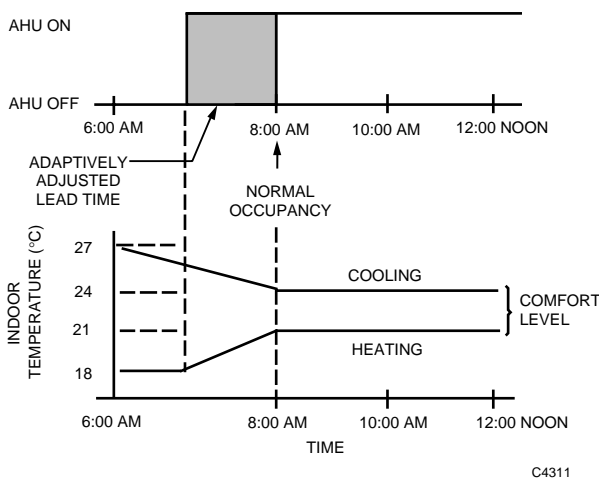

Fig. 5. Optimum Start.

Optimum Stop

The optimum stop program (Fig. 6) uses stored energy to handle the building load to the end of the occupancy period. Based on the zone temperatures that have the greatest heating and greatest cooling loads, and the measured heating and cooling drift rates, the program adjusts equipment stop time to allow stored energy to maintain the comfort level to the end of the occupancy period. This program adapts itself to changing conditions.

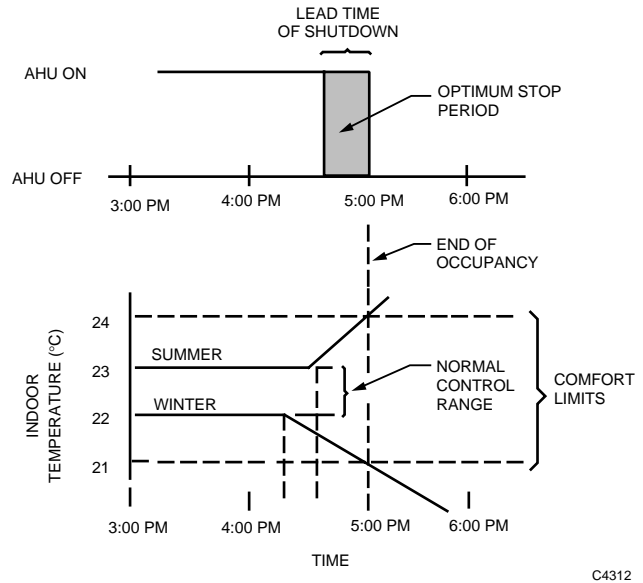

Fig. 6. Optimum Stop.

Night Cycle

The night cycle program (Fig. 7) maintains a low temperature limit (heating season) or high temperature limit (cooling season) during unoccupied periods by cycling the air handling unit while the outdoor air damper is closed. Digital control systems often reduce fan capacity of VAV AHU systems to accomplish this and reduce energy usage.

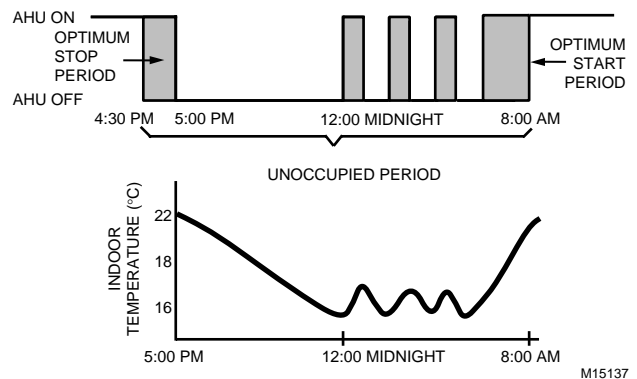

Fig. 7. Night Cycle.

Night Purge

The night purge program uses cool, night outdoor air to precool the building before the mechanical cooling is turned on. Digital control systems often reduce fan capacity of VAV AHU systems during Night Purge to reduce energy usage. Outdoor temperature, outdoor RH or dewpoint, and space temperature are analyzed. One hundred percent outdoor air is admitted under the following typical conditions:

1. Outdoor air above a summer-winter changeover point, such as 10°C.
2. Outdoor temperature below space temperature by a specified RH or determined differential.
3. Outdoor air dewpoint less than 16°C.
4. Space temperature above some minimum for night purge such as 24°C.

Enthalpy

The enthalpy program (Fig. 8) selects the air source that requires the least total heat (enthalpy) removal to reach the design cooling temperature. The selected air source is either the return air with a selectable minimum amount of outdoor air or a mixture of outdoor and return air as determined by local control from discharge-air or space temperature measurement. Measurements of return-air enthalpy and return-air dry bulb are compared to outdoor air conditions and used as criteria for the air source selection. A variation of this, although not recommended, is comparing the outside air enthalpy to a constant (such as 63.96 kilojoules per kilogram of dry air) since the controlled return air enthalpy is rather stable.

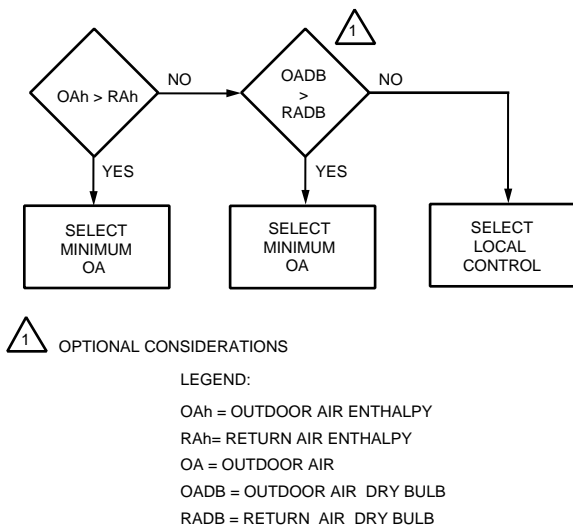
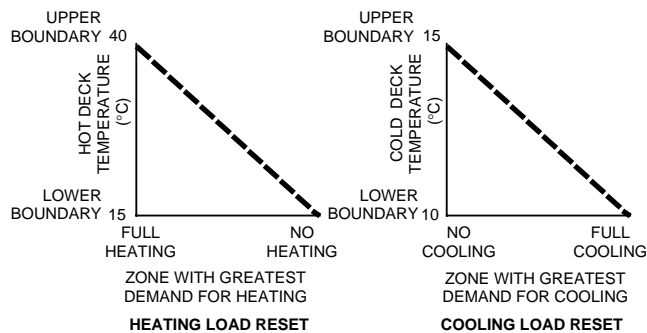

Fig. 8. Enthalpy Decision Ladder.

Load Reset

The load reset program (Fig. 9) assures that only the minimum amount of heating or cooling energy is used to satisfy load requirements. Samples of zone demands are taken and the zone with the greatest load is used to reset the temperature of the heating or cooling source.



C4315

Fig. 9. Typical Load Reset Schedules.

Load reset used with digital controllers is the application that most sets digital control apart from pneumatic and traditional control. The application uses VAV box loadings to determine VAV AHU requirements for air static pressure and temperature, uses reheat valve loadings to determine hot water plant requirements for temperature and pressure, and uses chilled water valve positions to determine chilled water plant requirements for temperature and pressure. These adjustments to the various requirements reduce energy costs when all VAV dampers are less than 70 percent open and AHU design conditions (for example, 13°C at 0.5 kPa static pressure) are not required.

Without knowledge of the actual instantaneous demands of the loads that load reset controls, systems must run at the theoretical worst-case setpoints for temperature and pressure.

As with most powerful application programs, load reset requires a great depth of knowledge of the HVAC and control process. The problem is that if load demands indicate that a higher chilled water temperature would be appropriate and the temperature increase is made, all loads are upset because of the chilled water temperature change. The loads must adjust and stabilize before another load reset adjustment is made. Monitoring and tuning is required to assure high performance control and loop stability. Three parameters determine the performance and stability of the system: the magnitude of the incremental corrections, the time interval between correction, and the magnitude of the hysteresis between raising and lowering the temperature.

C2439

Sun, weather, and occupancy (building utilization) dictate load reset demands. The sun and weather effects are relatively slow and occur as the sun and seasons change. Occupancy changes are abrupt and occur over brief periods of time.

If a chiller plant with 6.5°C design chilled water temperature is controlled to increase chilled water temperature any time all control valves are less than 80 percent open. Two air handling units with different control sequences are compared.

1. Control valves are on a VAV AHU chilled water coil and are part of a 13°C discharge air temperature control loop.

The load reset sequence events are:

- a. The most demanding AHU valve closes to below 80 percent open.
- b. The load reset program raises the chilled water temperature setpoint.
- c. The chiller unloads to maintain the raised setpoint.
- d. As the chilled water temperature increases, the discharge air temperature increases.
- e. The discharge air temperature controls open the AHU valves to maintain the discharge air temperature setpoint.
- f. The most demanding AHU valve opens to greater than 80 percent but less than 95 percent.
- g. The other AHU valves open increasing the chiller load.
- h. The two temperature loops stabilize in time. The chiller loop is usually set for a fast response and the discharge air loop is set for a slow response.

2. Control valves are on single zone AHU chilled water coil, controlled from space temperature at 24.5°C.

- a. The most demanding AHU valve closes to below 80 percent open.
- b. The load reset program raises the chilled water temperature setpoint.
- c. The chiller unloads to maintain the raised setpoint.
- d. As the chilled water temperature increases, the discharge air temperature increases.
- e. The space temperature control opens the valves to maintain the space temperature setpoint. This response takes several minutes in space temperature control.
- f. The most demanding AHU valve opens to greater than 80 percent but less than 95 percent.
- g. The other AHU valves open increasing the chiller load.
- h. The two temperature loops stabilize in time. The chiller loop is usually set for a fast response and the discharge air loop is set for a slow response.

The events of the first scenario occur within seconds because both loops (leaving water temperature controlling the chiller load and discharge air temperature controlling chilled water flow) are close coupled and fast. Because the two loops oppose each other (a chilled water temperature rise causes discharge air temperature to rise which demands more chilled water flow), a few minutes must be allowed for system stabilization. The chilled water temperature control loop should be fast and keep the chilled water near the new setpoint while the AHU temperature loops slowly adjust to the new temperature.

Hysteresis is a critical load reset parameter. Water temperature is raised if all valves are less than 80 percent open but, is not lowered until one valve is greater than 95 percent open. This 15 percent dead band allows lengthy periods of stability between load reset increases and decreases. Properly tuned load reset programs do not reverse the commands more than once or twice a day.

Scenario 1 initial parameters could be; command chilled water temperature increments of 0.2 kelvins, a load reset program execution interval of 4.0 minutes, a decrement threshold of 80 percent, (most demanding valve percent open), an increment threshold of 95 percent (most demanding valve percent open), a start-up chilled water temperature setpoint of 7°C, a maximum chilled water temperature setpoint of 10.5°C, and a minimum chilled water temperature setpoint of 6.5°C. The load reset chilled water temperature program may include an AUTO-MANUAL software selector and a manual chilled water temperature setpoint for use in the manual mode.

Unlike scenario 1, the events within scenario 2 occur over several minutes (not seconds) because when the chilled water temperature setpoint is raised, it takes several minutes for the water temperature rise and the resulting air temperature increase to be fully sensed by the space temperature sensor.

Scenario 2 parameters could be the same as scenario 1 with the exception of the execution interval which should be about 15 minutes.

All parameters should be clearly presented and easily commandable. Figure 10 is an example of dynamic data display for scenario 1.

CHILLED WATER TEMPERATURE SETPOINT CONTROL

- 8 MANUAL SETPOINT
- AUTO AUTO-MANUAL SELECTOR
- 7 CURRENT LEAVING WATER TEMPERATURE
- 36 CURRENT CHILLER LOAD (% AMPS)

CURRENT VALUE CHILLED WATER VALVES	
AHU #	% OPEN
1	68
2	73
3	74
4	77
5	79
6	70
7	64
8	69
9	79
10	74
11	74
12	74

AUTOMATIC MODE SEQUENCE OF CONTROL

ANYTIME ANY AHU CHW VALVE IS \gt 95 % OPEN, THE CHW TEMPERATURE SETPOINT WILL BE DECREMENTED 0.2 DEGREES, BUT TO NO LESS THAN 6 DEGREES.

ANYTIME ALL AHU CHW VALVES ARE \lt 80 % OPEN, THE CHW TEMPERATURE SETPOINT WILL BE INCREMENTED 0.2 DEGREES, BUT TO NO GREATER THAN 11 DEGREES.

THIS PROGRAM EXECUTES EVERY 4.0 MINUTES.

M15138

Fig. 10. Dynamic Data Display Example

Load reset works best when the number of monitored loads are between 2 and 30. If any monitored load is undersized or stays in full cooling for any reason, reset will not occur. See the Air Handling Systems Control Applications section and the Chiller, Boiler, and Distribution System Control Applications section for other load reset examples.

Zero Energy Band

The zero energy band (Fig. 11) program provides a dead band where neither heating nor cooling energy is used. This limits energy use by allowing the space temperature to float between minimum and maximum values. It also controls the mixed-air dampers to use available outdoor air if suitable for cooling. On multizone fan systems with simultaneous heating and cooling load capability, zone load reset controls the hot and cold deck temperature setpoints.

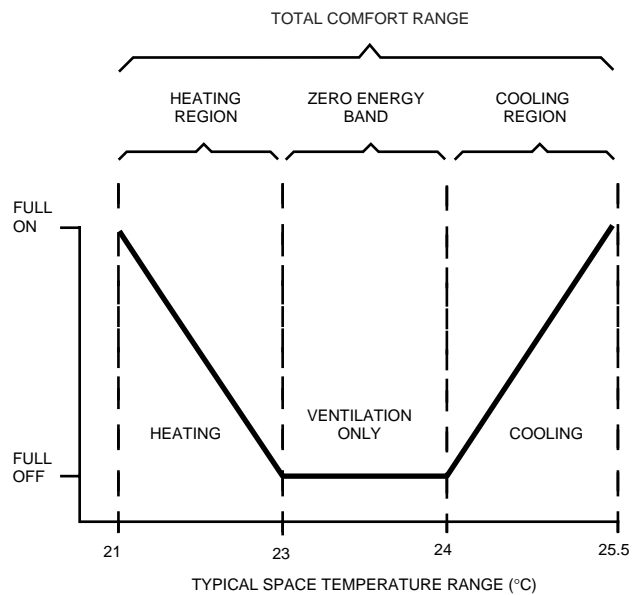

C4314

Fig. 11. Zero Energy Band.

Distributed Power Demand

The distributed power demand program (Fig. 12) is only applicable to microprocessor controllers with intercommunications capability. The demand program is resident in a single controller which monitors the electrical demand and transmits the required load shed or restore messages to other controllers on the communications bus or within the network. Each individual controller has prioritized load shed tables so that when a message to shed a specific number of kilowatts is received it can respond by shedding its share of the load. The basic demand program normally utilizes a sliding window demand algorithm and has provision for sequencing so that the same loads are not always shed first when a peak occurs.

It should be noted that there is interaction between the power demand program, duty cycle program, time schedule programs, and optimum start and stop programs. Therefore, a priority structure program is necessary to prevent control contentions.

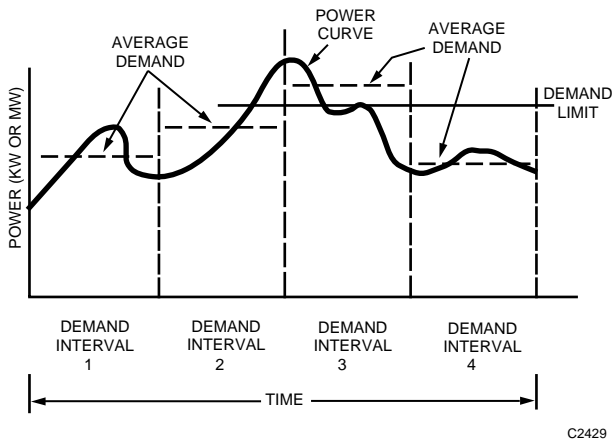

C2429

Fig. 12. Typical Power Curve Over Four Successive Demand Intervals.

CONTROLLER PROGRAMMING

GENERAL

The term programming as it pertains to microprocessor-based controllers relates primarily to setting up the controller for the given application. Zone-level controllers require initialization, selection of control algorithms and parameters, definition of control sequences, and establishing reference data bases. For zone-level controllers, the programming effort can be as simple as selecting the applicable control sequence from a library of programs resident in a configurable controller. For highly customized applications, usually encountered at the

BUILDING MANAGEMENT SOFTWARE

Microprocessor-based controllers are used extensively as data gathering panels (DGP) for building management systems. Since a microprocessor-based controller is already in place to provide DDC, IAQ, and EMS functions, many sensors and data files can be shared with building management system (BMS) functions. The distribution of many BMS functions into controllers throughout the premises increases the overall system reliability. The following BMS software is normally included in the controller.

Alarm lockout: Permits designated alarm points to be locked out from reporting process depending on the status of another point, e.g., discharge temperature alarm can be locked out when fan is off and during initial startup periods.

Alarm monitoring: Scans all analog and digital points and tests for alarm status. Sets of high and low limits for analog inputs are stored in the controller.

Communications module: Controls transmissions between controllers and between controllers and a central computer based on an established bus protocol.

Global points: Allows designated points to share their data with other bus connected devices.

Run time: Accumulates equipment on or off time and transmits totals periodically to the central system. On-off cycle counting can also be accumulated as a maintenance indicator. Alarm annunciation occurs if run time or cycle count limits are exceeded.

Time and event programs: Initiates a predetermined series of control actions based on an alarm condition, a point status change, time of day, or elapsed time. Points acted upon can be resident in any controller.

system controller level, a problem oriented language or a subset of a high-level language can be used to define control loops and sequences.

The means of entering a program can vary from a keypad and readouts on the controller to an operator terminal in a large centrally based computer configuration. Sophistication of the entry device is directly related to how well defined and fixed the control application is compared to the degree of customization or end-user modifications required. If considerable customization or modification is required, data entry could require a centrally based computer or a portable PC.

PROGRAMMING CATEGORIES

Programming of microcomputer-based controllers can be subdivided into four discrete categories:

1. Configuration programming.
2. System initialization programming.
3. Data file programming.
4. Custom control programming.

Some controllers require all four levels of program entry while other controllers, used for standardized applications, require fewer levels.

CONFIGURATION PROGRAMMING

Configuration programming consists of selecting which preprogrammed control sequence to use. It requires the selection of hardware and/or software packages to match the application requirements. Configuration programming can be as simple as selecting a specific controller model that matches the specific application requirements, or it can require keyboard selection of the proper software options in a more complex controller. Universal type controllers, typically applied as zone-level controllers for VAV or other terminal units, are usually preprogrammed with several control sequences resident in memory. In these cases, configuration programming requires selecting the proper control sequence to match the application through device strapping or keyboard code entry.

SYSTEM INITIALIZATION PROGRAMMING

System initialization programming consists of entering appropriate startup values using a keypad or a keyboard. Startup data parameters include setpoint, throttling range, gain, reset time, time of day, occupancy time, and night setback temperature. These data are equivalent to the settings on a mechanical control system, but there are usually more items because of the added functionality of the digital control system.

DATA FILE PROGRAMMING

Data file programming may or may not be required depending on whether the controller is a fixed-function or variable-function device. Zone-level controllers are typically fixed function since the applications and control sequences are generally standardized. In these controllers, the input terminals are dedicated to a specific sensor type and range, and the output

terminals are dedicated to a control relay or specific type of actuator. The need for data files is minimized. The processor always knows what to look for as it scans those points, and it knows how to process the data.

System-level controllers are variable-function and are more universal in application. These controllers must be able to perform a wide variety of control sequences with a broad range of sensor input types and control output signals. System-level controllers require more extensive data file programming. For the controller to properly process input data, for example, it must know if the point type is analog or digital. If the point is analog, the controller must know the sensor type, the range, whether or not the input value is linear, whether or not alarm limits are assigned, what the high and low alarm limit values are if limits are assigned, and if there is a lockout point. See Table 2. If the point is digital, the controller must know its normal state (open or closed), whether the given state is an alarm state or merely a status condition, and whether or not the condition triggers an event-initiated program.

Table 2. Typical Data File for Analog Input.

Point Address	User Address
Point type	Regular or calculation
Sensor	Platinum (-20 to 40°C)
Physical terminal assigned	16
Use code	Cold deck dry bulb
Engineering unit	°C
Decimal places for display	XXX.X
High limit	21.0
Low limit	4.0
Alarm lockout point	Point address
Point descriptor	Cold deck temperature
Alarm priority	Critical

CUSTOM CONTROL PROGRAMMING

Custom control programming is the most involved programming category. Custom control programming requires a step-by-step procedure that closely resembles standard computer programming. A macro view of the basic tasks is shown in Figure 13.

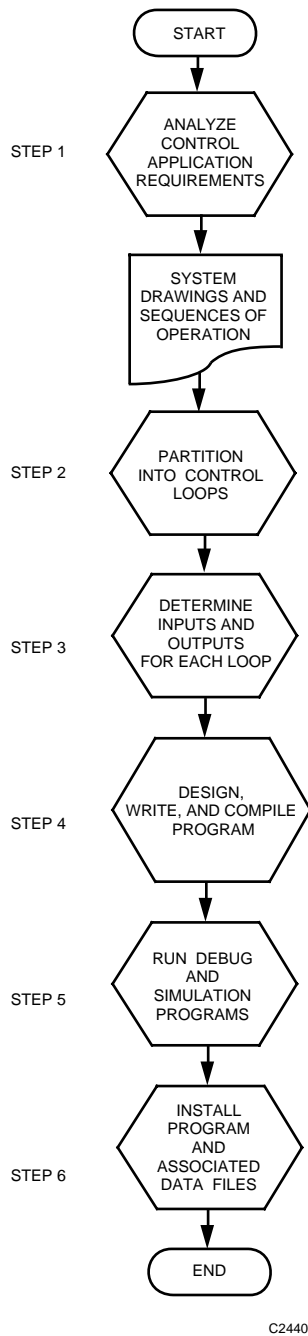

Fig. 13. Custom Control Program Development.

Analyze Control Application

The systems analysis step in writing a custom control programs requires that the control engineer thoroughly understand the process controlled. The output of the systems analysis is normally a system drawing and a concise and clearly stated sequence of operation.

Partition Into Control Loops

The next step is to partition the entire process into individual control loops. The Control Fundamentals section defines a control loop as a process in which a controller compares the measured value of a controlled variable to a desired value or setpoint. The resulting output of the controller goes to an actuator that causes a control agent to lessen the deviation between actual and desired values (Fig. 14). Control loops can be complex when limit control is needed or when several actuators are controlled in sequence to maintain the controlled variable. At this step a flow chart should be drawn showing all relationships influencing the controlled variable between the controller and actuators.

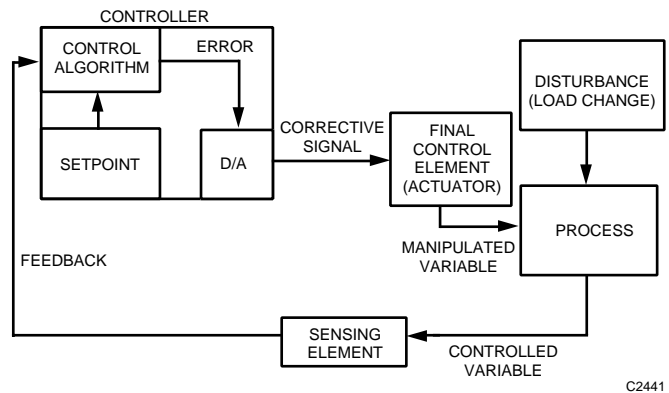

Fig. 14. Simple Control Loop.

A typical central fan system may require several control loops including various combinations of:

- Discharge-air temperature control
- Mixed-air temperature control
- Hot-deck temperature control
- Cold-deck temperature control
- Humidity or dewpoint control
- IAQ control
- Ventilation control
- Supply fan static pressure control
- Return fan airflow control

Determine Inputs and Outputs

The next step in custom control programming is to determine the inputs and outputs associated with each control loop. This establishes the data file associated with the program.

Design, Write, and Compile Program

The actual process of designing and writing the control loop programs can be a very complex or a relatively straightforward procedure, depending on the language processing software provided for the controller. The microprocessor-based controller understands instructions only at the most elementary language level, i.e., strings of 1s and 0s or machine code. Because of this, language processing software is often required. This software translates the instructions of a control program written in an easier-to-use high-level language into actual machine code. The terms compiler, assembler, object oriented, or interpreter are used to describe types of language processing software packages. The assembler is normally associated with a lower level assembly language while the compiler, object oriented, or interpreter is normally associated with a higher level language. Most system level controllers today are programmed using an object oriented (graphical) language.

Object-oriented languages are custom software packages tailored to the requirements of a specific vendor's controller. Control sequences are built by selecting preprogrammed control blocks, for example the PID algorithm, and linking them with

other control blocks. Although this process requires little or no knowledge of programming, it does require in-depth knowledge of the control blocks and the specific HVAC process.

Debug, Install, Enter Data Files, and Test

Regardless of the custom control program used, each program must be debugged to assure proper operation. When programs are written on a host machine, special debug and simulation programs are frequently employed prior to installing the program in the controller. Debug programs test for syntax (language) and procedural errors. Simulation programs allow inputs and outputs to be simulated and a static test of the program to be run. After debug and error correction, the program and associated data files are loaded into the controller and a full system check is made under normal operating conditions to assure proper operation.

Some systems allow graphically constructed programs to be monitored live in their actual executing environment with inputs, outputs, and intermediate signal values updating continuously.

TYPICAL APPLICATIONS

ZONE-LEVEL CONTROLLER

Zone-level controllers can be applied to a variety of types of HVAC unitary equipment. Several control sequences can be resident in a single zone-level controller to meet various application requirements. The appropriate control sequence is selected and set up through either a PC for the system or through a portable operator's terminal. The following two examples discuss typical control sequences for one type of zone-level controller used specifically for VAV air terminal units. For further information on control of terminal units, refer to the Individual Room Control Applications section. As stated in the introduction, the following applications are for stand-alone controllers. See the Building Management System Fundamentals section for network applications.

EXAMPLE 1. VAV COOLING ONLY

In a pressure independent VAV cooling only air terminal unit application the zone-level controller controls the primary airflow independent of varying supply air pressures. The airflow setpoint of the controller is reset by the thermostat to vary airflow between field programmable minimum and maximum

settings to satisfy space temperatures. On a call for less cooling, the damper modulates toward minimum. On a call for more cooling, the damper modulates toward maximum. The airflow control maintains the airflow at whatever level the thermostat demands and holds the volume constant at that level until a new level is called for. The minimum airflow setting assures continuous ventilation during light loads. The maximum setting limits fan loading, excessive use of cool air, and/or noise during heavy loads.

EXAMPLE 2. VAV COOLING WITH SEQUENCED ELECTRIC REHEAT

In a VAV cooling air terminal unit application with sequenced electric reheat, an adjustable deadband is provided between the cooling and the reheat cycle. During cooling the control mode is constant discharge temperature, variable volume. On a call for less cooling, the damper modulates toward minimum flow. The damper remains at minimum cooling through a deadband. On a call for reheat, the damper goes from minimum flow to reheat flow to ensure proper air distribution and prevent excessively high discharge temperatures and to protect the reheat elements. In this sequence, duct heaters are cycled and

staged by a PI algorithm with software heat anticipation. See Figure 15. During reheat, the control mode changes to constant volume, variable discharge temperature.

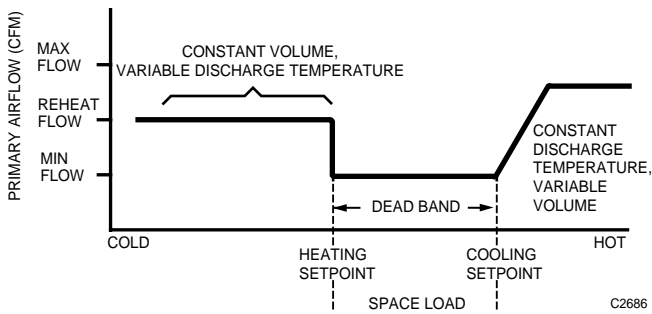

Fig. 15. Control Sequence for VAV Cooling with Sequenced Electric Reheat.

SYSTEM-LEVEL CONTROLLER

System-level controllers are variable-function devices applied to a wide variety of mechanical systems. These controllers can accommodate multi-loop custom control sequences and have control integrated with energy management and building management functions. The examples that follow cover direct digital control functions for a system-level controller. Integrated building management functions are covered in the Building Management System Fundamentals section.

Where the examples indicate that user entered values are furnished (e.g., setpoint), or that key parameters or DDC operator outputs will have display capability, this represents sound software design practice and applies whether or not the controller is tied into a central building management system. Data is entered or displayed in non-BMS applications by a portable operator’s terminal or by a keypad when display is integral with the controller.

A five-step approach can be used to define DDC programs.

1. Develop a system flow schematic as a visual representation of the process to be controlled. The schematic may be provided as a part of the plans and specifications for the job. If not, a schematic must be created for the system.
2. Add actuators, valves, sensors, setpoints, and operational data required for control and operation.
3. Write a detailed sequence of operation describing the relationship between inputs, outputs, and operational data points.

4. Develop a detailed flowchart of the control sequence using either DDC operators or a programming logic flow diagram. Programs written totally in a high-level language use the logic flow diagram.
5. Write the program using either DDC operators (Table 1) or high-level language statements.

An example of this approach follows for control of a hot water converter:

Step 1—Develop flow schematic of the process to be controlled (Fig. 16).

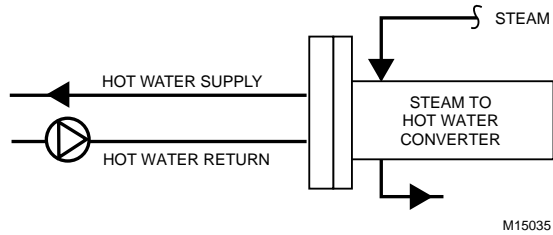

Fig. 16. Schematic of Steam to Hot Water Converter.

Step 2—Identify required sensors, actuators, and operational data (Fig. 17). Refer to the Chiller, Boiler, and Distribution System Control Applications section for a symbol legend.

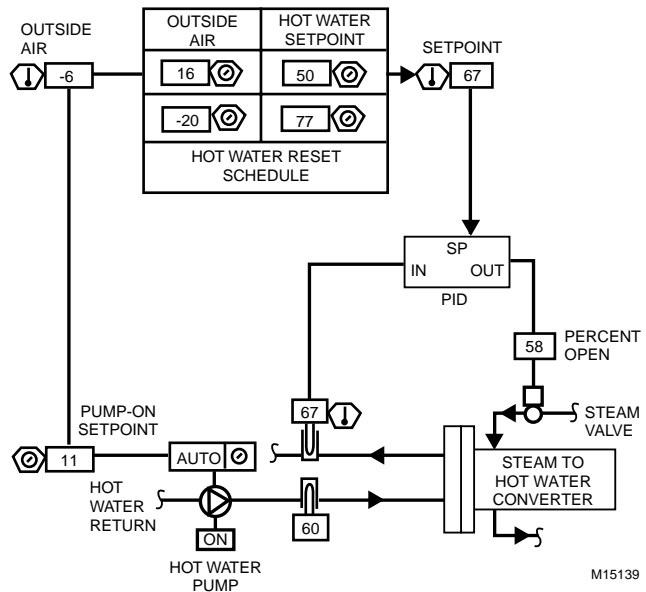

Fig. 17. Schematic Illustrating Sensors, Actuators, and Operational Data for Steam to Hot Water Converter.

If the DDC system is provided with a BMS having a color monitor, a graphic may be required to be displayed with live, displayable and commandable points (12 total). If a BMS is not provided, the points may be required to be displayed on a text terminal (fixed or portable) at the system level controller.

Step 3—Write a detailed sequence of operation for the process.

The hot water pump starts anytime the outside air temperature drops to 11°C, subject to a software on-off-auto function.

When hot water pumping is proven by a current sensing relay, converter controls are energized. Hot water temperature setpoint varies linearly from 50°C to 77°C as the outside air temperature varies from 16°C to -20°C. The converter steam valve is modulated to maintain a converter leaving water temperature according to a varying reset schedule.

The steam valve closes anytime hot water pumping is not proven and anytime the valve actuator loses motive power.

Step 4—Develop the detailed flowchart.

Step 5— Write the program.

See the Air Handling System Control Applications section and the Chiller, Boiler, and Distribution System Control Applications section for other examples of Microprocessor-Based/DDC systems.

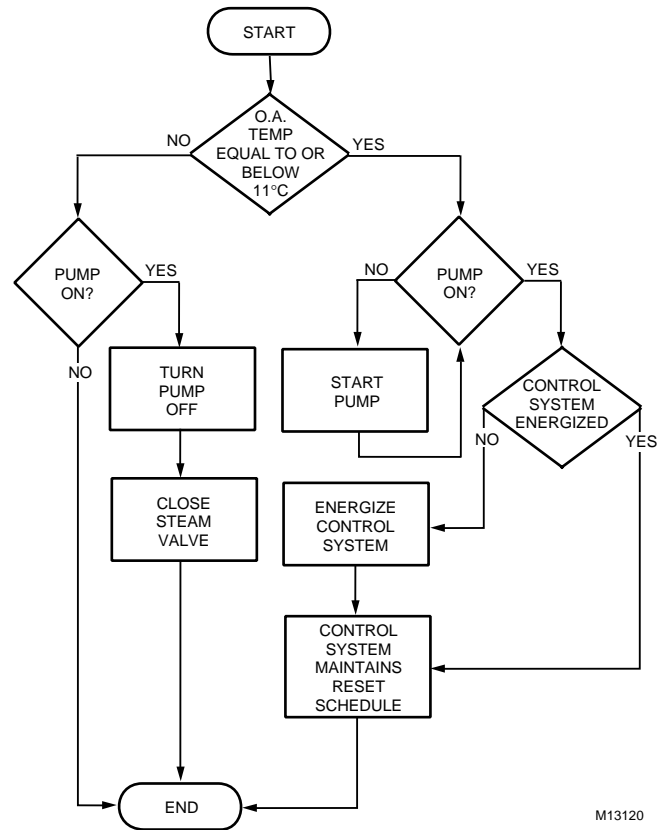

Fig. 18. Flowchart Example.

Indoor Air Quality Fundamentals

ENGINEERING MANUAL OF AUTOMATIC CONTROL

CONTENTS

Introduction	151
Definitions	151
Abbreviations	153
Indoor Air Quality Concerns	154
Air Contaminants	154
Contaminant Sources	154
Outdoor Contaminant Sources	154
Indoor Contaminant Sources	155
General	155
Building Materials and Furnishings	155
Occupancy and Process Related Contaminant Sources	156
Residential Occupancy	156
Office Building Occupancy	156
Health Care Occupancy	157
Industrial Occupancy	157
Occupant Related Contaminant Sources	157
Contaminant Types	157
Particulate Contaminants	157
Gas and Vapor Contaminants	158
Radionuclide Contaminants	158
Indoor Air Contaminant Indicators	158
Human Responses to Contaminants	158
Building Responses to Contaminants	158
Design Considerations	158
General	158
Eliminating Contaminant Sources	158
Eliminating Contaminant Paths	158
Remediating Contaminant Levels	159
Particulate Contaminant Remediation	159
Gas Contaminant Remediation	159
Effects of Temperature	159
Effects of Humidity	160
Design Procedures	160
General	160
Ventilation Rate Design Procedure	161
Indoor Air Quality Design Procedure	161
Recirculation Requirements	162
Ventilation Optimization	162
Codes and Standards	162
Acceptance Testing	163
General	163
ASHRAE Guideline 1-1989	164

Indoor Air Quality Control Applications	164
General	164
Flow Tracking Control System	165
Flow Tracking System with Mixing Box Static Pressure Control	166
Rooftop Unit Control System	167
Operator Interface	167
Graphic Displays	168
Bibliography	170
Referenced Publications	170
Related Publications	170

INTRODUCTION

This section provides basic information on Indoor Air Quality (IAQ) and suggested control solutions. The causes and effects of several contaminants are discussed. These contaminants provide reason for concern about IAQ. Also included are recommended or required approaches to IAQ compliance and general approaches to preventing and controlling IAQ problems. In addition, typical graphic displays are included illustrating the usefulness of an operator interface to allow pinpointing and correcting any problems that might cause degradation of IAQ. Displays, requiring acknowledgment, can also be provided to alert the operator that periodic maintenance of IAQ is required.

The issue of indoor air quality (IAQ) has moved from virtual non-existence to a major concern over the last twenty years.

Measures taken to offset increasing energy costs since the 1970s, increasing use of synthetic materials in building construction and maintenance, compressed construction schedules, and reduction in operational maintenance resulting from competitive pressures have made IAQ a major problem for the building designer, operator, and owner.

A correctly designed control system properly applied to a well designed HVAC system can ensure optimal IAQ, which in turn will ensure occupant comfort and improved employee productivity. A poorly designed, installed, or maintained control system can reduce IAQ below acceptable levels, resulting in reduced productivity, increased employee health costs and building maintenance costs, and major legal costs.

DEFINITIONS

To control IAQ it is necessary to understand the terms commonly in use by the various agencies involved in industry and government which relate to the many disciplines involved.

Aerosol: Liquid droplets or solid particles, suspended in air, that are fine enough (0.01 to 100 micrometers) to remain dispersed for a period of time.

Air cleaner: A device that actively removes impurities from the air. Includes particle filters, gas phase filters and electronic devices.

Air quality standard: A government-mandated regulation which specifies the maximum contaminant concentration beyond which health risks are considered to be unacceptable.

Allergen: A substance that can trigger immune responses resulting in an allergic reaction; also known as antigen.

Bacteria: One celled organisms which are members of the protista, a biological classification.

Bakeout: A technique for reducing emissions of new construction in which the building temperature is raised (usually to at least 32°C) for several days to enhance emissions of volatile compounds from new materials, while running the ventilation system at full capacity to exhaust the emissions.

Bioaerosols: Airborne microbial contaminants, including viruses, bacteria, fungi, algae, and protozoa. The term also refers to the reproductive units, metabolites, and particulate material associated with these microorganisms.

Biocontaminant: Contaminants which are either life forms (molds of the genera aspergillus) or are derived from living things such as rodent droppings.

Building-related illness: A diagnosable illness with identifiable symptoms whose cause can be directly attributed to airborne pollutants within the building (e.g., Legionnaires disease, hypersensitivity pneumonitis).

Carcinogen: An agent suspected or known to cause cancer.

Commissioning:

- **Building:** The process of designing, achieving, verifying, and documenting the performance of a building to meet the operational needs of the building within the capabilities of the design and to meet the design documentation and the owners functional criteria, including training of operating personnel.
- **HVAC System:** The process of documenting and verifying the performance of HVAC systems so that systems operate in conformity with the design intent.

Contaminant: An unwanted constituent that may or may not be associated with adverse health or comfort effects. See Pollutant.

Decay rate: The rate at which the concentration of a compound diminishes.

Dilution: The reduction of airborne concentration of contaminants through an increase in outdoor air supplied to the space.

Diocetyl phthalate: An oily liquid used in testing filters.

- Dose:** The amount of a given agent that actually reaches the site in the body where it causes an effect.
- Electrostatic air cleaner:** A device that has an electrical charge to trap particles traveling in the airstream.
- Emission:** The release of airborne contaminants from a source.
- Emission rate:** A measure of the quantity of a chemical released into the air from a given quantity of a source during a given amount of time.
- Emission standard:** Either a voluntary guideline or a government regulation that specifies the maximum rate at which a contaminant can be released from a source; also called source emission standard.
- Environmental Tobacco Smoke (ETS):** Combustion emissions (composed of over 3800 identifiable contaminants, including 43 known or suspected carcinogens) released either by burning tobacco or exhausted tobacco smoke.
- Flushout:** A pre-occupancy preventive procedure which involves running a ventilation system on its highest settings to remove the airborne emissions from newly installed furnishings and carpeting. See Bakeout.
- Formaldehyde (HCHO):** An odorous Volatile Organic Compound (VOC) that contains oxygen in addition to carbon and hydrogen which is usually in the form of a colorless gas at room temperature.
- Fungi:** Unicellular or multicellular eukaryotic organisms embracing a large group of microflora including molds, mildews, yeasts, mushrooms, rusts, and smuts.
- HEPA filter:** A classification of high-efficiency particulate air filters.
- Hypersensitivity disease:** A type of disease characterized by allergic responses to antigens.
- Indoor Air Quality (IAQ):** The characteristics of the indoor climate of a building, including the gaseous composition, temperature, relative humidity, and airborne contaminant levels.
- Legionnaires disease:** One of two important diseases (the other being Pontiac fever) that are caused by legionella pneumophila bacteria. The disease is a severe multisystemic illness that can affect not only the lungs but also the gastrointestinal tract, central nervous system, and kidneys.
- Materials Safety Data sheets (MSDSs):** OSHA required documents supplied by manufacturers of potentially hazardous products. MSDSs contain information regarding potentially significant airborne contaminants, precautions for inspection, health effects, odor description, volatility, expected contaminants from combustion, reactivity, and procedures for spill cleanup.
- Micro-organisms:** Life forms too small to be seen with the unaided eye.
- Mitigation:** A procedure or strategy aimed at reducing or eliminating an indoor air problem, through source control, ventilation control, exposure reduction, and air cleaning.
- Multiple Chemical Sensitivities (MCS):** A medical condition affecting several organs in which a person reports sensitivity to very low doses of a variety of chemicals after an identifiable chemical exposure to one chemical.
- National Ambient Air Quality Standard (NAAQS):** The U.S. outdoor air quality standards designed to protect public health. Pollutants covered by the NAAQS include ozone, sulfur dioxide, nitrogen dioxide, lead, respirable particulates, and carbon monoxide.
- Occupied Zone:** The area in a room or building in which most human activity takes place, considered by ASHRAE to be between 75 and 1830 millimeters from the floor and 600 millimeters from walls or fixed equipment.
- Off gassing:** The release of gases, such as organic vapors, from a building material after the manufacturing process is complete.
- Particulates:** Small airborne particles found in the indoor environment that include fibrous material, solid-state semivolatile organic compounds such as Polycyclic Aromatic Hydrocarbons (PAHs), trace metal, and biological materials.
- Permissible Exposure Limit (PEL):** Air contaminant standards set by OSHA.
- 4-phenylcyclohexene(4-PC):** An odoriferous compound that is a by-product of the manufacture of styrenebutadiene.
- Pollutant:** A contaminant that is known to cause illness; often used synonymously with contaminant.
- Pollutant pathway:** Route of entry of an airborne contaminant from a source location into the occupant breathing zone through architectural or mechanical connections (e.g. through cracks in walls, vents, HVAC system ducts, and open windows).
- Radon:** A colorless, odorless, radioactive gas emitted during the disintegration of radium. Radon can be a serious indoor air contaminant in building areas which are in contact with or are penetrated by gases emitted from radium containing bedrock or building stones.
- Respirable Suspended Particles (RSP):** Inhalable particulate matter; particles less than 10 micrometer in diameter.
- Sick building:** A building in which the IAQ is considered to be unacceptable to a majority of occupants.

Sick Building Syndrome (SBS): A term used to refer to the condition in which a majority of building occupants experience a variety of health and/or comfort effects linked to time spent in a particular building, but where no specific illness or causative agent can be identified. Symptoms often include headaches, eye irritation, and respiratory irritation.

Sink: A material with the property of absorbing a chemical or pollutant with the potential of subsequent reemission; sometimes called a sponge.

Source control: A preventive strategy for reducing airborne contaminant levels through the removal of the material or activity generating the pollutants.

Stressor: Any biological, chemical physical psychological, or social factor that contributes to a complaint.

Threshold: The contaminant dose or exposure level below which there is no expected significant effect.

Total Volatile Organic Compounds (TVOCs): A measure representing the sum of all VOCs present in the air.

Toxicity: The nature and degree of a given agent's adverse effects on living organisms.

Volatile Organic Compound (VOC): One of a class of chemical components that contain one or more carbon atoms and are volatile at room temperature and normal atmospheric pressure. In indoor air, VOCs are generated by such sources as tobacco smoke, building products, furnishings, cleaning materials, solvents, polishes, cosmetics, deodorizers, and office supplies.

ABBREVIATIONS

The following abbreviations are used throughout this section in the text and drawings.

AHU — Air Handling Unit
ASHRAE — American Society of Heating, Refrigerating and Air Conditioning Engineers
ANSI — American National Standards Institute
BOCA — Building Owners and Code Administrators
BMS — Building Management System
DNR — Department of Natural Resources
C — Celsius
CDC — Center for Disease Control
CO — Carbon monoxide
CO₂ — Carbon dioxide
DOP — Dioctyl phthalate
EA — Exhaust Air
ETS — Environmental Tobacco Smoke
HCHO — Formaldehyde
HEPA — High Efficiency Particulate Filter
EPA — Environmental Pollution Agency
IAQ — Indoor Air Quality
IDLH — Immediately Dangerous to Life and Health
L/s — Liters per second
MA — Mixed Air
MCS — Multiple Chemical Sensitivities
MSDS — Materials Safety Data Sheets
NAAQ — National Ambient Air Quality Standard
nCi/m³ — Nanocuries per cubic meter
NIOSH — National Institute of Occupational Safety & Health

NO₂ — Nitrogen Dioxide
NRC — Nuclear Regulatory Commission
O₃ — Ozone
OA — Outdoor Air
OSHA — Occupational Safety and Health Agency
4-PC — 4-Phenylcyclohexene
PAH — Polycyclic Aromatic Hydrocarbons
Pb — Lead
PEL — Permissible Exposure Limit
PMV — Predicted Mean Vote
ppb — Parts per billion
ppm — Parts per million
PHD — Public Health Department
RA — Return Air
RH — Relative Humidity
RSP — Respirable Suspended Particles
SBC — Southern Building Code
SA — Supply Air
SO₂ — Sulfur Dioxide
SBC — Southern Building Code Officials
SBS — Sick Building Syndrome
SP — Supply Pressure
STEL — Short Term Exposure Limit
SMACNA — Sheet Metal and Air Conditioning Contractors National Association
TLV — Threshold Limit Value
TSP — Total Suspended Particulates
TVOC — Total Volatile Organic Compounds
UBC — Uniform Building Code
µg/m³ — Micrograms per cubic meter
VAV — Variable Air Volume
VOC — Volatile Organic Compound

INDOOR AIR QUALITY CONCERNS

AIR CONTAMINANTS

Air contaminants are categorized by location and type. Location of contaminants is divided between outdoor and indoor. Outdoor air contamination results from natural or manmade phenomena that occur outdoors or indoors. Contaminant types include particulate, gas, vapor, radionuclide.

CONTAMINANT SOURCES

Outdoor Contaminant Sources

Outdoor contaminant sources are divided into above ground and below ground sources. Above ground sources are subdivided into man made and naturally occurring sources. Man made sources are those such as electric power generating plants, various modes of transportation (automobile, bus, train ship, airplane), industrial processes, mining and smelting, construction, and agriculture. These contaminants can be loosely classified as dusts, fumes, mists, smogs, vapors, gases, smokes that are solid particulate matter (smoke frequently contains liquid particles), and smokes that are suspended liquid particulates. Naturally occurring contaminant sources include pollen, fungus spores, viruses, and

bacteria. Gaseous contaminants such as methane are produced both naturally, by animals and decay, and by man made activity such as landfills. Location near a fossil fuel power plant, refinery, chemical production facility, sewage treatment plant, municipal refuse dump or incinerator, animal feed lot, or other like facility will have a significant effect on the air introduced into a building.

Below ground sources include radon gas and its by products. Radon gas is found in all soils in various concentrations. It is a product of the radioactive decay of radium. Radon, in turn, generates other radioactive contaminants as it decays. Radon gas enters buildings primarily through the foundation. Radon can then decay through a succession of decay products, producing metallic ions. These products become attached to particulate matter suspended in the air and can then be inhaled causing health problems.

Outdoor air pollution is monitored and regulated at the Federal level by the U.S. Environmental Protection Agency (EPA) which has set primary and secondary standards for several pollutants known as criteria pollutants. These criteria pollutants include: nitrogen dioxide (NO₂), ozone (O₃), carbon monoxide (CO), sulfur oxides, nonmethane hydrocarbons, lead (Pb), and total suspended particulates (TSP). The EPA estimates that 50 percent of American cities do not meet all these standards for 1996. See Tables 1 and 2.

Table 1. Annual Median Concentrations for TSP, NO₂, O₃, & CO—1979. ^a

Location	Concentration			
	TSP (annual average) ^b	μg/m ³ NO ₂ (1 hr average)	O ₃ (1 hr average)	mg/m ³ CO (1 hr average)
Baltimore	43-102	45	20	1.5
Boston	67	75	—	3.5
Burbank, Ca.	—	124	39	3.5
Charleston, WV	43-70	37	14	1.2
Chicago	56-125	63	29	2.9
Cincinnati	47-87	60	24	1.0
Cleveland	58-155	89 ^c	26	2.0
Dallas	43-73	59 ^c	39	1.4
Denver	80-194	89	37	4.6
Detroit	52-135	68	14	1.8
Houston	51-147	90 ^c	39 ^d	1.0
Indianapolis	48-81	91 ^c	33	2.7
Los Angeles	90	85	117	2.6
Louisville	60-102	70 ^c	31	1.5
Milwaukee	47-105	86 ^c	41	1.4
Minneapolis	45-87	65 ^c	—	1.8
Nashville	41-82	62 ^c	49 ^d	2.6
New York	40-77	57	35	5.5
Philadelphia	51-109	85	39	3.2

(continued)

Table 1. Annual Median Concentrations for TSP, NO₂, O₃, & CO—1979. ^a (continued)

Location	Concentration			
	TSP (annual average) ^b	μg/m ³ NO ₂ (1 hr average)	O ₃ (1 hr average)	mg/m ³ CO (1 hr average)
Pittsburgh	88-162	—	29 ^d	3.9
St. Louis	63-107	90 (d)	22 ^d	2.3 ^d
San Diego	57-75	69	39	1.1
San Francisco	51	46	20 ^e	2.1
Washington DC	47-70	52	29	1.6

^a EPA (1980)

^b Annual geometric mean of 24 hr averages

^c 24 hr averages

^d Not a full year

^e Total oxidants

Source: Walden and Schiff (1983)

Table 2. U.S. Ambient Air Quality Standards.

Pollutant	Averaging Time	Primary Standard Levels	Secondary Standard Levels
Particulate matter	Annual (geometric mean)	75 μg/m ³	60 μg/m ³
	24 hr ^b	260 μg/m ³	150 μg/m ³
Sulfur oxides	Annual (arithmetic mean)	80 μg/m ³ (0.03 ppm)	—
	24 hr ^b	365 μg/m ³ (0.14 ppm)	—
	3 hr ^b	—	1300 μg/m ³ (0.5 ppm)
Carbon monoxide	8 hr ^b	10 mg/m ³ (9 ppm)	10 mg/m ³ (9 ppm)
	1 hr ^b	40 mg/m ³ (35 ppm) ^c	40 mg/m ³ (35 ppm)
Nitrogen dioxide	Annual (arithmetic mean)	100 μg/m ³ (0.05 ppm)	100 μg/m ³ (0.05 ppm)
Ozone	1 hr ^b	240 μg/m ³ (0.12 ppm)	240 μg/m ³ (0.12 ppm)
Hydrocarbons (nonmethane) ^a	3 hr (6 to 9 A.M.)	160 μg/m ³ (0.24 ppm)	160 μg/m ³ (0.24 ppm)
Lead	3 months	1.5 μg/m ³	1.5 μg/m ³

^a A nonhealth-related standard used as a guide for ozone control.

^b Not to be exceeded more than once a year.

^c EPA has proposed a reduction of the standard to 29 μg/m³ (25 ppm).

Source: U.S. Environmental Protection Agency.

Indoor Contaminant Sources

GENERAL

Indoor contaminant sources are generated by the occupants, the processes conducted, construction, renovation and maintenance activities, and the building materials and furnishings.

BUILDING MATERIALS AND FURNISHINGS

Building materials and furnishings generate Volatile Organic Compounds (VOCs) including 4 to 16 carbon alkanes, chlorinated hydrocarbons, alcohols, aldehydes, ketones, esters, terpenes, ethers, aromatic hydrocarbons (e.g. benzene and toluene), and heterocyclics. Building generated contaminants are highest immediately after installation, reducing to a lower

level due to off gassing and ventilation, and then remain at that level for an extended period.

However, the VOC concentrations increase during unoccupied night and weekend periods when there is no ventilation. Also, increased temperature increases the output of VOCs from building materials. Table 3 lists Sources, Possible Concentrations, and Indoor to Outdoor Concentration Ratios of some indoor Pollutants (source: NRC 1981).

Concentrations listed are only those reported indoors. Both higher and lower concentrations have been measured. No averaging times are given. NA indicates it is not appropriate to list a concentration.

For a detailed discussion of air contaminants refer to ASHRAE Fundamentals Handbook 1997 Chapter 9, Indoor Environmental Health, and Chapter 12, Air Contaminants.

Table 3. Sources, Possible Concentrations, and Indoor to Outdoor Concentration Ratios of some Indoor Pollutants.

Pollutant	Sources of Indoor Pollution	Possible Indoor Concentrations	Indoor/Outdoor Concentration Ratio	Location
Asbestos	Fireproofing	<10 ⁶ fiber/ m ³	1	Homes, schools, offices
Carbon Dioxide (CO ₂)	Combustion, humans, pets	3000 ppm	>>1	Homes, schools, offices
Carbon Monoxide (CO)	Combustion equipment, engines, faulty heating systems	100 ppm	>>1	Skating rinks, offices, homes, cars, shops
Formaldehyde	Insulation, product binders, particleboard	0.05 to 1.0 ppm	>1	Homes, offices
Mineral & Synthetic Fibers	Products, cloth, rugs, wallboard	NA	∞	Homes, schools, offices
Nitrogen Dioxide (NO ₂)	Combustion, gas stoves, water heaters, dryers, cigarettes, engines	200 to 1000 g/m ³	>>1	Homes, Skating rinks
Organic Vapors (VOCs)	Combustion, solvents, resin products, pesticides, aerosol sprays	NA	>1	Homes, offices, public facilities, restaurants, hospitals
Ozone	Electric arcing, UV light sources	20 ppb 200 ppb	<1 >1	Airplanes offices
Radon & Progeny	Building materials, ground water, soil	0.1 to 200 nCi/m ³	>>1	Homes, buildings
Respirable Particles	Stoves, fireplaces, cigarettes, condensation of volatiles, aerosol sprays, resuspension, cooking	100 to 500 g/m ³	>>1	Homes, offices, cars, public facilities, bars, restaurants
Sulfate	Matches, gas stoves	5 g/m ³	<1	Removal inside
Sulfur Dioxide (SO ₂)	Heating system	20 g/m ³	<1	Removal inside
TSP without Smoking	Combustion, resuspension, heating system	100 g/m ³	1	Homes, offices, transportation, restaurants
Viable Organisms	Humans, pets, rodents, insects, plants, fungi, humidifiers, air conditioners	NA	>1	Homes, offices, hospitals, schools, public

Occupancy And Process Related Contaminant Sources

Process generated contaminants vary with the nature of the occupancy and processes. All occupancies have some common contaminants. Additional contaminants depend on the occupancy type (residential, office building, health care, or industrial) and the associated processes.

RESIDENTIAL OCCUPANCY

Residential contaminant sources include tobacco smoke, detergent, waxes, pesticides, polishes, cosmetics, mothballs, and building materials. Gas ranges, wood stoves, and kerosene heaters are major sources of concern because of carbon

monoxide. Showers can be a source of radon gas and halocarbon concentrations, but usually are not run often enough to be of concern. Some fungi, mold, and mildew found in showers can be quite harmful if left unchecked. Occupants, both human and animal, are also significant sources.

OFFICE BUILDING OCCUPANCY

Office contaminant sources include tobacco smoke, detergent, waxes, pesticides, polishes, cosmetics, and building materials. Additional sources include electrostatic copiers (ozone), diazo printers (ammonia and related compounds), carbonless copy paper (formaldehyde), and correction fluids, inks, and adhesives (VOCs). Fungus, mold, and mildew from cooling towers, humidifiers, dehumidifiers, and showers is also a source.

HEALTH CARE OCCUPANCY

Health care occupancies have process contaminants similar to office occupancies. Additional health care process sources are anesthetic gases and sterilizers, infectious diseases including drug resistant tuberculosis (TB), and lint from bedding. Because many patients have weakened immune systems, higher priorities must be given to the disease sources.

INDUSTRIAL OCCUPANCY

Indoor contaminant sources in industrial occupancies generally are dominated by the processes taking place. Most concern is concentrated on the materials, solvents and by-products of a process which is moderately or highly toxic, with little concern for lesser sources. The traditional approach to industrial air quality has been to capture the process air, exhaust it to the outdoors, and provide sufficient make-up air to replace the exhaust component.

If the more toxic sources are controlled, the lesser sources are assumed to be under control. The Occupational Safety and Health Agency (OSHA) sets maximum safe levels for most common and dangerous materials and requires that materials safety data sheets be completed on each of these substances.

The National Institute of Occupational Safety & Health (NIOSH) also publishes a list which includes additional substances and a value index for items Immediately Dangerous to Life and Health (IDLH).

Occupant Related Contaminant Sources

Humans and animals emit a wide array of pollutants by breath, sweat, and flatus.

For example CO₂ is generated by people in all types of buildings, and there is a measurable correlation between occupant activity and CO₂. In office structures and non industrial facilities CO₂ is a major consideration. In Health Care facilities humans are also a source of infectious bioaerosols, including drug resistant TB. Tobacco smoke is a major contaminant. Its use has declined in most occupancies except for a concern for residences and bars. The human tracheo-bronchial system serves, somewhat, as a pollution control device by acting like a saturated adsorber by removing a portion of contaminants such as VOCs.

For a detailed discussion of odors refer to ASHRAE Fundamentals Handbook 1997, Chapter 13, Odors.

CONTAMINANT TYPES

Particulate Contaminants

Particulates consist of aerosols, dust, fumes, and smoke and contain a wide range of materials, types, and sizes. Particulate contaminants can be solid, liquid-gas dispersoids, or soils. Aerosols include viruses, bacteria, fungus spores and pollen. Particle sizes vary from 0.001 to several thousand micrometers. Solid particles smaller than 100 micrometers are classified as dust. Fumes are solid particles formed by the condensation vapors of solid materials starting as air borne particles smaller than 1 micrometer and accumulating with age to larger clusters. Smoke is small solid and/or liquid particles produced by incomplete combustion of organic substances. Smoke particles vary from in size from 0.01 to 1 micrometer.

Figure 1 lists a variety of common particles found in the air. This figure also illustrates the effectiveness of an electronic air cleaner when compared to a standard furnace filter.

AIR CLEANER PARTICLE CHART

Particles visible with . . . Particle Size in Microns	Electron Microscope		Optical Microscope		Naked Eye	
	.001	.01	.1	1	10	100
HONEYWELL EAC EFFECTIVE RANGE	[Shaded area from .001 to .1 microns]					
DUST/LINT FILTER EFFECTIVE RANGE*	[Shaded area from 10 to 100 microns]					
PARTICULATES						
Human Hair					••••••••	
Viruses	••••••••••••••					
Bacteria		••••••••••••••				
Skinflakes			••••••••••••••			
Pollen				••••••••••••••		
Plant Spores					••••••••••••••	
Sneeze Droplets					••••••••••••••	
Dust Mites					••••••••	
SMOKE (PARTICLES)						
Carbon Particles	••••••••••••••					
Cooking/Grease		••••••••••••••				
Tobacco Smoke		••••••••••••••				
Wood Smoke		••••••••••~•••••				
DUSTS						
Household Dust	••••••••••••••	••••••••••~•••••				
Insecticide Dusts	••••~••••••••••					
Soil Dust				••••••••••~•••••		
Coal Dust				••••••••••~•••••		
Animal Dander			••••••••~•••••			
ATMOSPHERIC PARTICLES						
Smog	••••••~••••••••					
Clouds/Fog				••••••~•••••		
Mist					••••••	

* THE EFFICIENCY OF DUST/LINT FURNACE FILTERS DECREASES RAPIDLY ON PARTICLES BELOW 100 MICRONS, AND ARE VIRTUALLY INEFFECTIVE ON PARTICLES BELOW 10 MICRONS. M1248B

Fig. 1. Characteristics of Particles.

Gas And Vapor Contaminants

The terms gas and vapor are often used to describe a common state of a substance. Gas normally describes any mixture, except atmospheric air, that exists in the gaseous state at normal atmospheric conditions. Examples are oxygen, helium, and nitrogen, all naturally occurring useful gases, and ozone, an unstable ion of oxygen which is a contaminant.

Vapor describes a substance in the gaseous state that can also exist as a liquid or solid at normal atmospheric conditions. Examples include contaminants such as gasoline, benzene, carbon tetrachloride, and life sustaining water.

Radionuclide Contaminants

Radioactive contaminants can be particulate or gaseous and emit alpha, beta, or gamma rays. Alpha rays present no hazard, except when the material is deposited inside or on the body. Beta rays are more penetrating and are both an internal and an external hazard. The penetrating ability of gamma rays depends on their energy, which varies with the type of radioactive element or isotope.

Radioactive materials present problems that make them distinctive. The contaminants can generate enough heat to damage filtration equipment or ignite materials spontaneously. The concentrations at which most radioactive materials are hazardous are much lower than those of ordinary materials.

INDOOR AIR CONTAMINANT INDICATORS

HUMAN RESPONSES TO CONTAMINANTS

Humans respond to contaminated and uncomfortable environments in predictable and known ways. Responses to contaminants in the air can be coughing, sneezing, nausea, breathlessness, drowsiness, headaches, depression, and eye, throat, and skin irritation. All of these lead to annoyance and loss of productivity if not illness. Odors are more easily detected when relative humidity is high. These symptoms often lead to complaints or cases of sick building syndrome, building related illness, or multiple chemical sensitivity, all of which have economic costs.

Sick Building Syndrome is the term applied to buildings with no specific, identifiable contaminants, but with at least 20 percent of the occupants complaining of a problem that subsides after exiting the building. Complaints often result from discomfort from temperature or humidity rather than IAQ problems.

Building Related Illness is the term applied to a specific identifiable medical condition of known etiology that is documented by physical signs and laboratory tests.

Multiple Chemical Sensitivity is the term applied to an illness resulting from exposure to multiple chemicals, none of which by itself would cause a problem in most people.

BUILDING RESPONSES TO CONTAMINANTS

Building responses to indoor air contamination include visual signs of fungus, mold, mildew, dirt buildup, corrosion, and discoloration. The growth of fungus, mold, and mildew is found in showers, duct work, local humidifiers and dehumidifiers, mechanical spaces, cooling towers, and also on walls and windows.

Dirt buildup occurs around supply air diffusers, in filter banks, on coils, and in duct work.

Corrosion, embrittlement, and discoloration result from gaseous contaminants causing chemical reactions, usually with moisture, in high relative humidity conditions.

DESIGN CONSIDERATIONS.

GENERAL

The generally accepted rules for improving IAQ are:

1. Eliminate the source.
2. Eliminate the path.
3. Remediate the level of contaminants that cannot otherwise be eliminated.

These rules are discussed in the following as well as the effects of temperature and humidity on the occupants..

ELIMINATING CONTAMINANT SOURCES

Controlling the source of contaminants requires identifying and categorizing contaminants into those that can and those that cannot be eliminated. Sources that can be eliminated by good design principals are selection of building materials and furnishings that eliminate VOCs. Building occupants and their process items are sources that cannot be eliminated. Where sources cannot be eliminated they must be controlled to minimize their prevalence and removed or reduced to acceptable levels. An example is applying a fume hood to a stove or other process. Another example is substituting for the process chemical.

ELIMINATING CONTAMINANT PATHS

Pathways for airborne contamination are categorized as active or passive. Active pathways are those where a mechanical device aids movement of the contaminant. Passive pathways are those where gravity or pressure differential provide the motive force.

Passive pathways include vertical elevator and mechanical shafts which permit gravity flow of airborne contaminants, and drop ceilings, tunnels, and partition walls where mold, mildew and fungus may be growing, spreading, and generating spores. Frequently, exterior walls are found to permit entry of water, moisture, and contaminated outdoor air. In large spaces such as manufacturing areas and atriums, pressure differentials cause the movement of contaminants.

Active pathways for air contamination include HVAC systems, cooling towers designed into the building, and local spot humidifiers, dehumidifiers, fans and heaters added by the occupants after occupancy. If the contaminants are not trapped or eliminated at the source, the HVAC systems can move them throughout the building. Since the HVAC system is the primary active pathway for contamination it plays a significant role in the solution to the IAQ problem. Filtration is a significant aspect of the HVAC system where air is recirculated.

Cooling towers that are not properly treated can promote the growth of legionella which may then be introduced into the HVAC system and spread throughout the building. Local devices such as humidifiers and dehumidifiers can promote fungus growth and spread it into the room space where it is picked up by the HVAC system and distributed throughout the building. While designers cannot control what the occupants place in the building after turnover, they can provide documentation and education as to the limits of the systems installed.

HVAC systems operating at 100 percent outdoor air produce indoor air concentrations of contaminants that approach outdoor concentrations. If there is a 50 percent probability that the outdoor air will not meet NAAQ standards there is a 50 percent probability the IAQ will be substandard unless filtration systems are designed for these contaminants. This includes HVAC systems with economizers during moderate weather conditions.

REMEDIATING CONTAMINANT LEVELS

Particulate Contaminant Remediation

Methods of particulate remediation used to maintain acceptable IAQ levels include filters and electronic wire elements. Particulate filters are used to remove contaminants from the air stream. Standard particulate filters with a 75 percent dust spot efficiency will remove all pollen and larger particles as well as oil smoke. High efficiency HEPA filters having a DOP efficiency rating of 98 percent have been in use in the health care industry for many years. These remove viruses and bacteria. Portable and fixed installation HEPA filters are also available in the residential and light commercial market.

Gas Contaminant Remediation

Gas phase filtration is used to reduce and control gas and vapor contaminants. Gas phase filtration systems utilizing virgin coconut shell carbon activated to 60 percent carbon tetrachloride activity should be capable of removing parts per billion of Volatile Organic Compounds, ozone, nitrogen dioxide, and sulfur dioxide.

According to the EPA one half the population of the United States lives in areas that do not meet the National Ambient Air Quality Standards with ozone being the most prevalent contaminant. Electronic air cleaners are high efficiency filter devices that produce ozone as a by-product. Ozone is listed as a harmful contaminant, yet it has been used to improve IAQ by removing VOCs. If ozone is used as a filtration or cleaning device it is necessary to follow these devices with activated charcoal or other gas phase filters to removing any residual ozone.

Radioactive particles and gases can be removed from air by devices such as filters and absorption traps, but the gamma radiation from such material is capable of penetrating solid walls.

EFFECTS OF TEMPERATURE

Lack of thermal comfort control is an often ignored cause of presumed IAQ problems.

Discomfort is often confused with sick building syndrome. Thermal comfort is a function of six parameters: air temperature, mean radiant temperature, relative air velocity, humidity, activity level, and clothing thermal resistance. The International Organization for Standardization has adopted the Predicted Mean Vote (PMV) thermal comfort index to provide a method to index comfort and discomfort levels taking into account the six PMV parameters. PMV sensors are available on a limited basis. These sensors may become commonplace in the future, but for today most people who recognize that discomfort can create the perception of IAQ problems are focused on the temperature and relative humidity aspects of the problem.

Air is perceived to be fresher and less stuffy with decreasing temperature and relative humidity, and there is a direct correlation between increases in sick building syndrome and rises in room temperatures. The effect of temperature is linear and stronger than humidity. Temperature also effects relative humidity. For example, if space conditions are 26°C and 16 percent relative humidity and the temperature is decreased 4 degrees to 22°C, then the relative humidity will rise to 20 percent or a 4 percent increase. These conditions are not uncommon in the afternoon in the winter in temperate climates. Discomfort attributable to dry air can usually be remedied by lowering the air temperature a few degrees

Failing to maintain the temperature will affect the relative humidity which can have an adverse effect on the growth of viruses, mold, mildew, and bacteria. A temperature increase of 2.5 to 4 kelvins can double the levels of formaldehyde.

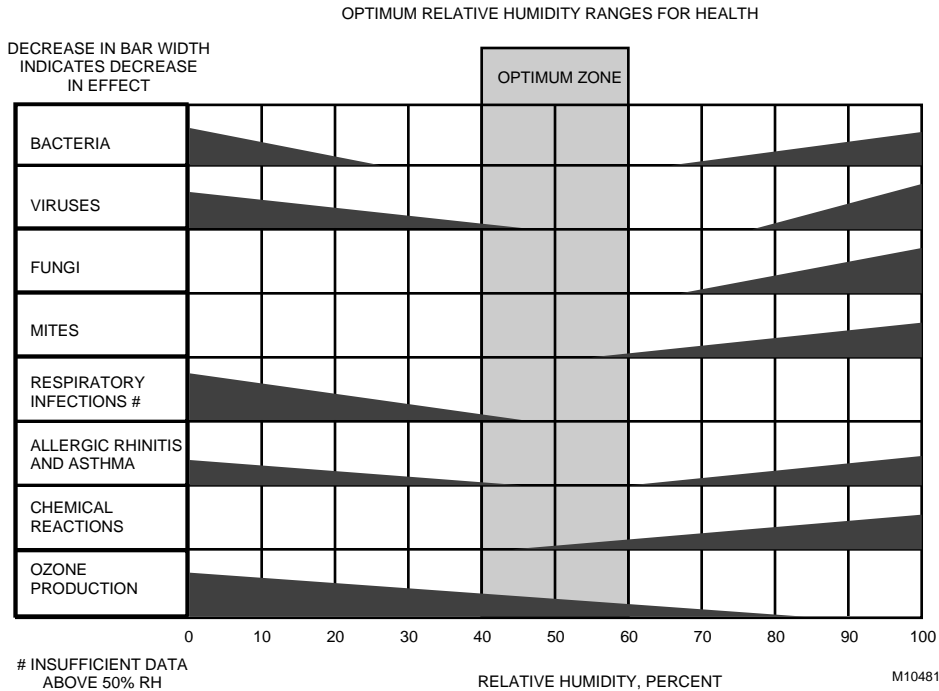

Fig. 2. Effect Of Changes in Relative Humidity on Various Items.

Effects of Humidity

Controlling relative humidity between 40 and 60 percent has a beneficial impact on health and therefore, productivity. Figure 2 shows the effect of relative humidity on bacteria, viruses, fungi, mites, respiratory infections, allergic rhinitis, asthma, chemical reactions, and ozone production. The choice of the optimum zone is a compromise. It is informative to note the overlap of ozone production and chemical reactions, since ozone is such an active oxidizer. Ozone may not be generated at high humidity, but if present it will certainly react. Also note that bacteria, viruses, fungi mites, and chemical reactions all thrive in the high moisture content found in the drain pans, humidifier discharges, and on the cooling coils if they are dehumidifying. Some state building codes prohibit humidification above 30 percent space levels in the winter except for special occupancy uses.

Refer to ASHRAE Standard 55-1992 Thermal Environmental Conditions for Human Occupancy for more information.

The relative humidity in the supply air duct after the humidifier will approach 100 percent and condense unless controlled. Condensation in the duct promotes the growth of mold and fungi and has been the source of air quality problems in many buildings. Proper maintenance is essential for the control of contaminants and bioaerosols. Assuming that return air relative humidity is the same as space relative humidity is a common mistake. They are

the same only if the two temperatures are the same. Maintaining the relative humidity below 60 percent frequently requires dehumidification by the cooling coil resulting in condensation of moisture on the coils. If this moisture is not removed through proper drainage it promotes the growth of mold and fungi and has been the source of air quality problems in many buildings.

DESIGN PROCEDURES

GENERAL

ASHRAE Standard 62-1989 sets the IAQ standard for design professionals by specifying the minimum ventilation rates and IAQ that are acceptable to human occupants and is intended to minimize the potential for adverse health effects. This standard defines two methods that can be used to achieve these goals.

- Ventilation Rate Procedure: Provides ventilation air of the specified quality and quantity to the space.
- Indoor Air Quality Procedure: Controls known and specifiable contaminants within the space.

This standard also requires detailed documentation of design assumptions and intent to permit the operating personnel to maintain the system as designed to assure continued IAQ during occupancy. The standard is currently in the normal review process. Many changes are being proposed, including incorporating code language, i.e., shall.

VENTILATION RATE DESIGN PROCEDURE

The Ventilation Rate Procedure is deemed to provide acceptable IAQ by providing an indirect solution to the control of IAQ.

Acceptable outdoor air is generally defined in terms of sulfur dioxide, carbon monoxide, ozone, nitrogen dioxide, lead, and particulate levels. If levels are too high the air “should” be treated (BOCA says high levels shall be treated). Exceptions allow recirculating air during rush hour traffic if treatment is not possible. Minimum outdoor air airflow per person are listed for each type of occupancy, for example 7.08 L/s for classrooms, 14.16 L/s for operating rooms, and 28.13 L/s for smoking lounges. These rates are set on the assumption that they will maintain CO₂ levels below 1000 ppm and that this is a valid indicator of acceptable IAQ. Recirculation of air to reduce quantities of outdoor air requires that air cleaning equipment be used to lower the contaminant levels to those required for

outdoor air and that the Indoor Air Quality Procedure must be used. The air cleaning equipment must be designed to reduce particulates and where necessary and feasible, gaseous contaminants.

Spaces with variable occupancy served by a common supply may have their fraction of the outdoor air requirement adjusted to match the occupancy. This requires additional sensors and controls. This can done with CO₂ sensors, occupancy sensors, VAV flow readings, and measurement of the outdoor air airflow.

Table 6.1b in ASHRAE Standard 62-1989 provides minimum ventilation requirements based on per person or square foot and nonsmoking. The table has many references and is excerpted and converted to SI units here as Table 4 with the recommendation that the latest ASHRAE publication on Ventilation For Acceptable Indoor Air Quality be consulted before using any of the data.

Table 4. Minimum Ventilation Requirements

	Prescriptive Requirements		Simple System Requirements	
	People R _p L/s per person	Building R _b L/s per m ²	Outside Air R _{sb} L/s per m ²	Supply Air R _{ss} L/s per m ²
Office Building				
General office space	2.83	0.356	0.660	0.660
High density open office space	2.83	0.356	0.660	0.813
Reception areas	3.30	0.356	0.914	1.321
Telecommunications/data entry	3.30	0.356	2.490	6.096
Conference rooms	2.36	0.356	1.625	5.080
Main entry lobbies	3.30	0.305	0.610	0.610

Excerpt of Table 6.1b (Converted to S-I units) from ASHRAE Standard 62-1989

INDOOR AIR QUALITY DESIGN PROCEDURE

The Indoor Air Quality Procedure provides a direct solution by restricting the concentration of all known contaminants of concern to specified acceptable levels. This procedure lists acceptable levels for CO₂, chlordane, ozone, and radon gas and references many other potential contaminants without defined limits. The use of CO₂ as an indicator of IAQ is inferred. The limit of 1000 ppm is recommended to satisfy comfort and odor criteria. The use of subjective evaluation implies an occupied building which further implies changes after occupancy.

The requirements for recirculation are similar to the Ventilation Rate Procedure.

Maintenance of acceptable IAQ is complicated by the use of variable air volume systems. Some designers choose to utilize

dual duct constant volume HVAC systems to simplify IAQ control. Use of direct drive variable geometry fans and innovative outdoor air economizer designs allow designers to provide both IAQ and energy efficiency.

Designers frequently use constant volume terminal boxes in their designs. One adaptation of this technology applies a constant volume terminal box to supply 100 percent conditioned outdoor air to a conference room when a motion sensor indicates that the room is occupied. This air is the ventilation component. The conference room is also served by a fan powered variable air volume box which cools and heats the room with centrally supplied primary air and recirculated air. Other designers apply constant volume terminal boxes in the outdoor air intakes of smaller VAV fan systems to ensure minimum outdoor air at all times. This may supply too much outdoor air at light loads depending upon the percentage of the load represented by occupants.

Recirculation Requirements

Recirculation of air in HVAC systems is regulated by buildings codes and other rules as well as ASHRAE 62-1989. The BOCA mechanical building code, for example, requires filtration to remove particulates above a certain level for recirculation.

Figure 3 shows locations where filtration might be appropriate in different system configurations. The filter shown in the space is located in a local makeup air unit if one is used. The filter shown in the outdoor airstream is utilized when outdoor air cannot meet the requirements of the building code, ASHRAE recommendations, or flow sensors or coils are located in the outside air.

Each of the filter locations shown might represent multiple particulate, gas phase, and/or ozone generators.

Ventilation Optimization

The Ventilation Rate and Air Quality Procedures both increase outdoor air consumption and increase operating cost unless techniques are used to minimize outdoor air when the spaces are not fully occupied. The two procedures require different approaches.

One approach utilized for the Ventilation Rate Procedure monitors the load, or airflow, of all the VAV terminal boxes and the outdoor air flow of the supply fan, calculates the required

ventilation fraction, and resets the outdoor airflow to the minimum outdoor air that will satisfy the critical space or spaces. See the latest version of ASHRAE Standard 62 for additional information on critical zone reset application.

An alternate method maintains a constant supply fan mixing box static pressure as the supply fan load varies. Since the entire Ventilation Rate Procedure is based on a series of assumptions, this lower cost, static pressure approach may be as effective and is certainly more cost effective.

When the Air Quality Procedure is used, CO₂ monitoring and control has been used to reduce outdoor air to conserve energy. However, CO₂ is only one of the possible contaminant in indoor air. It was intended as an index of odor quality on the assumption that if odor was low all other contaminants would also be low. This is not necessarily so. Some designers use VOC Sensors in lieu of or in addition to CO₂ sensing and control. The standard lists CO₂, Chlordane, Ozone, and Radon levels. Table 3 references other contaminants which may be of concern. The engineer is left to decide which ones are to be monitored.

CODES AND STANDARDS

A host of regulatory agencies, code bodies, and advisory agencies are involved in the maintenance of Air Quality. Some are concerned with Outdoor Air Quality while others are concerned only with IAQ. These agencies and their jurisdictions are listed in Table 5.

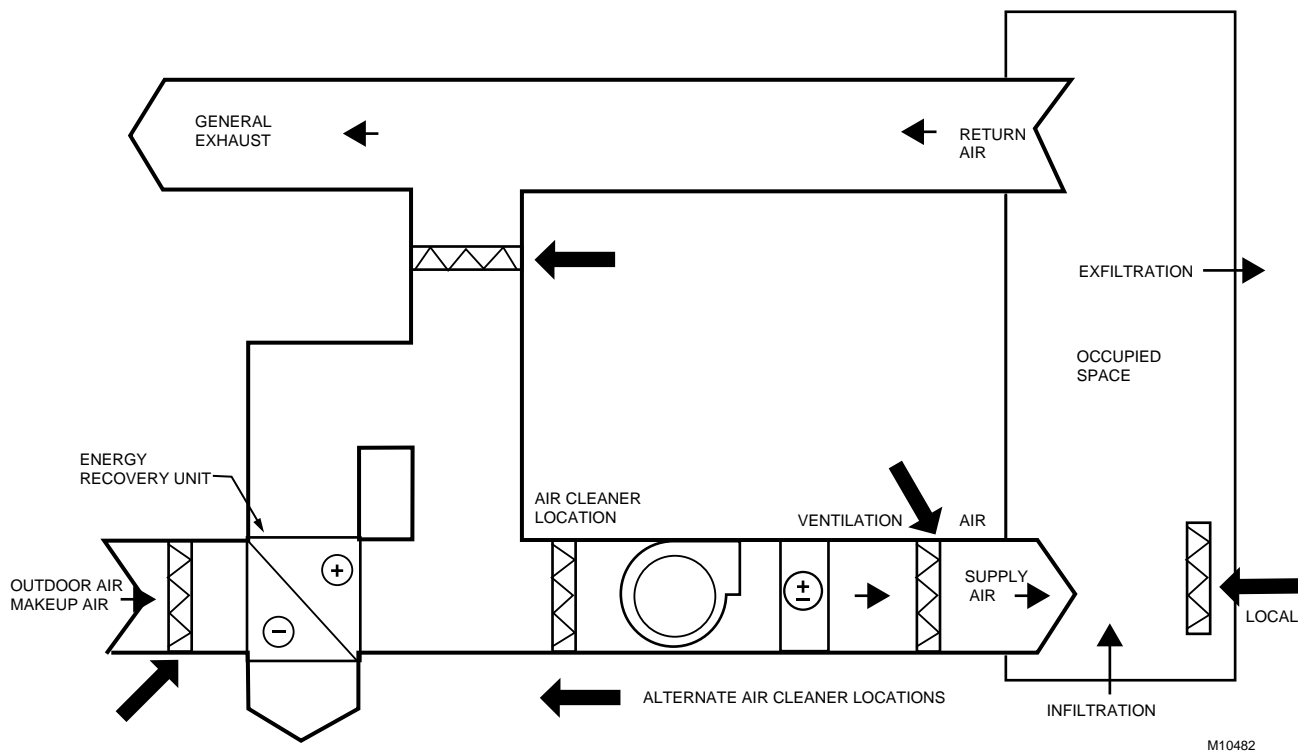

Fig. 3. Possible Location for Filtration in an HVAC System.

Table 5. Air Quality Regulatory Agencies.

Agency	Federal	State	Advisory
Environmental Protection Agency (EPA)	X		
Department of Natural Resources (DNR)		X	
Occupational Safety & Health Agency (OSHA)	X		
Center for Disease Control (CDC)	X		
Public Health Department (PHD)		X	
American Society of Heating, Refrigerating and Air Conditioning Engineers (ASHRAE)			X
American National Standards Institute (ANSI)			X
National Institute of Occupational Safety & Health (NIOSH)			X
Building Owners and Code Administrators (BOCA)			X
Southern Building Code SBC			X
Uniform Building Code (UBC)			X

Litigation can result from failure to comply with Federal, State, or Local laws and regulations, from negligence or failure to comply with commonly accepted standards under common law, or from failure to comply with the terms of design, construction or maintenance contracts, or under the workman’s compensations laws. Building insurance policies generally exclude pollution related damages.

Each regulatory agency has its own priorities. The EPA which is responsible for outdoor air quality sets the highest priority on source control of these contaminants. Ventilation control is their second priority and air cleaning the last priority. A traditional approach to IAQ is to exhaust the contaminated air to the outdoors. This exhaust is considered a source by EPA, but a solution by others. The Clean Air Act limits the exhaust of contaminated air to the outdoors. This is particularly true in the manufacturing sector but also impacts office buildings and health care facilities. This requires recirculation of the air with the use of better particulate filters, gas phase filters, and possibly ozone generators.

OSHA priorities are directed to industrial facilities and construction sites. OSHA sets the standards for the toxicity of over 490 compounds in the work place by establishing:

- The Acceptable Maximum Peak for a short exposure.
- The Acceptable Ceiling Concentration, not to be exceeded during an 8 hour shift. Others call this Short Term Exposure Limit STEL.
- The Time Weighted Average, not to exceed in any 8 hour shift of a 40 hour week. Also called the Threshold Limit Value TLV.

These are maximum safe levels of exposure and are too high to be of use for IAQ purposes. OSHA is currently promulgating standards for IAQ.

The CDC and Public Health Departments are primarily concerned with infectious diseases in healthcare facilities. Their regulations have a significant impact on HVAC systems for intensive care units, isolation rooms, and operating rooms in these facilities.

The American Society of Heating Refrigeration & Air Conditioning Engineers (ASHRAE) created design Standard 62-1989, Ventilation for Acceptable IAQ. This was adopted by the American National Standards Institute (ANSI) and has been incorporated into several state building codes. Even where 62-1989 has not been adopted into code it exerts a powerful influence because it establishes a standard which can be used in litigation. One of the key elements of this standard is documentation of design criteria for operations people.

The National Institute of Occupational Safety and Health (NIOSH) has published a list which includes additional substances, and a value for IDLH or Immediately Dangerous to Life and Health.

National model building code agencies such as Building Owners and Code Administrators (BOCA), the Southern Building Code Officials (SBC), and the Uniform Building Code (UBC) publish code standards which become law when adopted by states. These codes have provisions which govern HVAC systems. The three agencies have agreed to unify their codes into a single National Model Code. They have adopted the National Plumbing Code in 1995, the National Mechanical Code in 1996, and are currently working on the National Building Code.

ACCEPTANCE TESTING

GENERAL

Commissioning is the process designed to ensure that the HVAC system performs as designed before it is turned over to the owner and during the life of the building. Commissioning is a necessary step to acceptable IAQ. Adequate maintenance by trained personnel with an adequate budget is an essential ingredient in the solution of IAQ problems. The documentation required by ASHRAE 62-1989 is a necessary component of an informed maintenance program.

ASHRAE GUIDELINE 1-1989

ASHRAE Guideline 1-1989 for commissioning HVAC systems defines commissioning as “documenting and verifying the performance of HVAC systems so that systems operate in conformity with the design intent.” This guideline, in conjunction with ASHRAE Standard 62-1989, is a major tool for eliminating IAQ problems. The commissioning guideline, if implemented, requires system design and construction processes to ensure and facilitate implementing the verification process.

The commissioning process starts in the program development phase with owner buy in and continues throughout the schematic, design development, and construction phases of the pre-acceptance phase. The process includes clearly defined additional contractor responsibilities. Following the process during the preacceptance phase allows the acceptance phase to accomplish the desired goals.

The design phases of the commissioning process ensure that the systems will perform their intended functions. The construction phase ensures that the systems are installed to

deliver the design. The acceptance phase of the process demonstrates that the systems work as designed. Documentation requirements of the process ensure that the building operators know the design intent of the systems and how they are to be operated. This process is intended to ensure that owner changes are recommissioned.

The documentation, required by both ASHRAE Standard 62-1989 and Guideline 1-1989, provides the information necessary for proper operation and maintenance of the HVAC systems. The commissioning process requires the involvement of operating and maintenance personnel in the Acceptance process to ensure understanding of the design intent and operational requirements of the systems. Personnel turnover requires extensive additional training.

Assuming adequate funding of the operations and maintenance staff, the systems will deliver the design performance throughout the intended life cycle. Any alternations required by changes in occupancy requirements need to be correctly integrated into the system design through the use of a post commissioning process.

INDOOR AIR QUALITY CONTROL APPLICATIONS

GENERAL

To provide appropriate IAQ it is essential to maintain the building pressure slightly positive to prevent infiltration. Minimum and maximum air flows must be maintained to assure proper air distribution and internal pressurization zones. Terminal regulated air volume control of the supply fan should match the output to the load with a minimum input of energy. Use of Direct Digital Control (DDC) and related software capabilities can be used to provide control and provide information to the operator to permit better IAQ control and operator comprehension.

The following control system drawings appear fairly simple because they illustrate hardware only. The triangles represent physical connections to a DDC control panel. The related control functions are all in software programs and need to be shown on graphic displays for the engineer and building operator to visualize system operation. Refer to the OPERATOR INTERFACE and GRAPHIC DISPLAYS topics for a discussion of a typical operator interface.

For additional information on related control applications and DDC, refer to the following manual sections of this manual:

- Air Handling System Control Applications
- Building Airflow System Control Applications
- Microprocessor-Based/DDC Fundamentals

FLOW TRACKING CONTROL SYSTEM

Figure 4 provides a simplified hardware schematic of a variable volume supply and return fan system with flow stations in the supply and return to control the return fan volume to match the supply fan volume less any exhaust volume. A volume differential is maintained between the supply and return to pressurize the building. There may be only one such system in a building or there may be many. The supply fan static pressure setpoint, and thus the output volume, may be reset by the VAV

terminal box requirements that the fan supplies. Typically there are 30 to 70 VAV terminal units per fan system. The sample VAV terminal unit shown is a fan powered unit but the units could be non-fan powered. Without an air flow station in the outdoor air, this system might not deliver the minimum air flow at all fan volumes, because the mixing box negative static pressure and therefore the OA airflow varies with the supply fan load. If mixed air temperature is used to calculate the percentage of outdoor air, as the outdoor temperature approaches 10°C the margin of error increases because of the narrowing differential between outdoor air and mixed air.

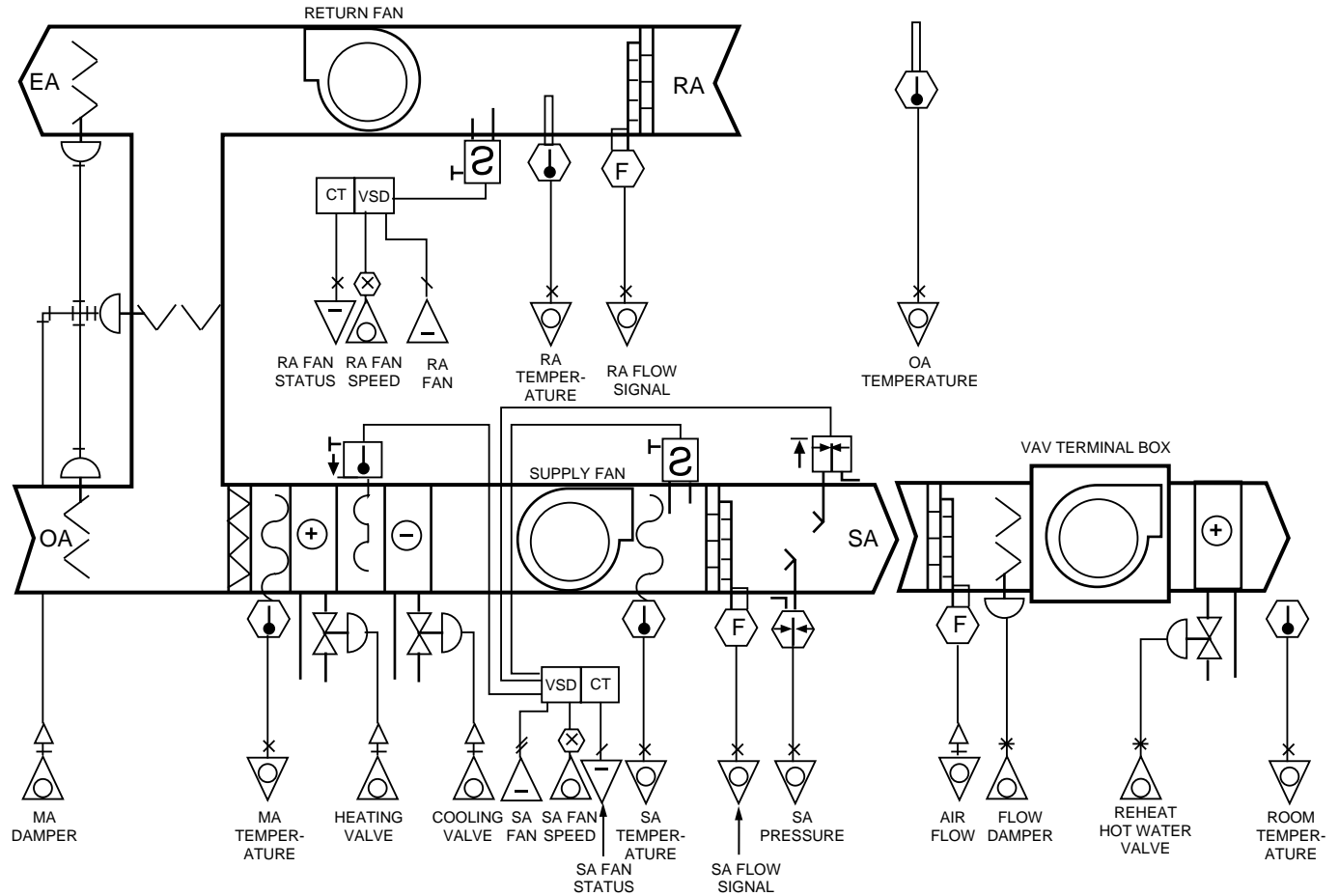

Fig. 4. HVAC Flow Tracking.

M10486

FLOW TRACKING SYSTEM WITH MIXING BOX STATIC PRESSURE CONTROL

Figure 5 is the same as the Flow Tracking System except for the addition of a method of controlling the amount of outdoor air. The outdoor air is controlled by maintaining a constant negative static pressure in the mixed air. The pressure sensor is referenced across the outdoor air damper which is maintained at a variable minimum position until the economizer calls for

additional outdoor air. During non-economizer periods the EA/RA dampers modulate to maintain static pressure constant at the filter inlet. This is accomplished by separating the control of the outdoor air damper from the control of the return and relief dampers. Note that the OA damper minimum position and the MA static pressure setpoint must be determined in conjunction with the air balancing contractor. Refer to VAV AHU WITH RETURN FAN AND FLOW TRACKING in the Air Handling System Control Applications section.

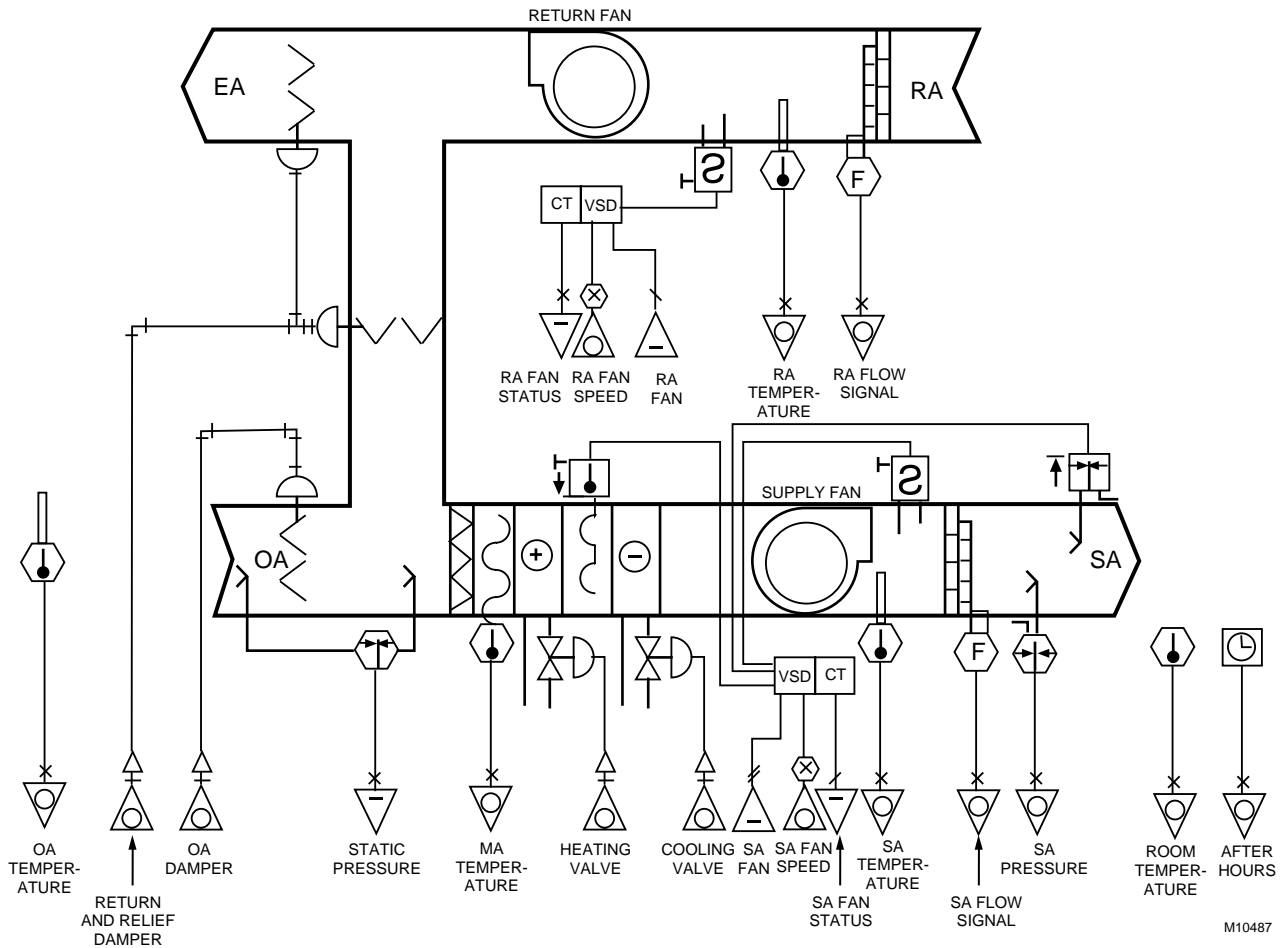

Fig. 5. HVAC Flow Tracking with Differential Pressure Control of OA.

ROOFTOP UNIT CONTROL SYSTEM

Figure 6 shows a typical packaged rooftop VAV system similar to the previous system but with humidification and without a return fan. Differential pressure mixed air control is well suited to roof top applications which usually do not have sufficient ductwork for flow station outdoor air measurement.

Without the return fan and with a two position exhaust fan it is difficult to ensure air balance in the building.

OPERATOR INTERFACE

Modern Building Management Systems (BMS) utilizing distributed direct digital controllers and personnel computer based local area networks are installed in many buildings. Full utilization of a BMS greatly simplifies the operations and maintenance tasks and provides prompt alert of IAQ problems. By furnishing quality of information knowledgeable operators and engineers can easily visualize the system, comprehend the current status, and determine the nature of any problem.

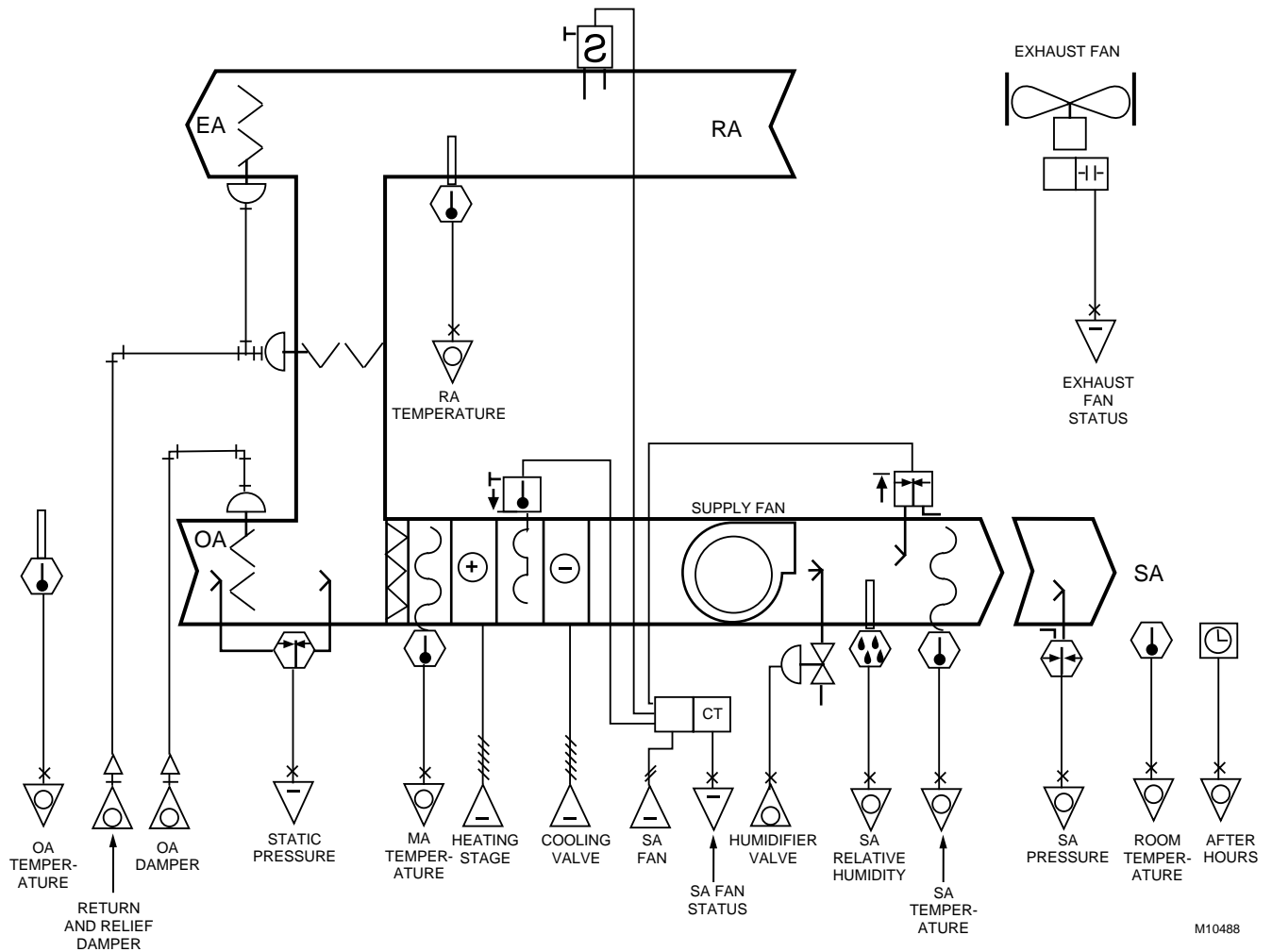

Fig. 6. Typical Rooftop HVAC System.

Operator graphic displays with meaningful real-time dynamic data displays can enable building operators to understand how the building is operating. CO₂, VOC, airflow, DP, SP, filter, and drain pan alarms can all provide operator information required to maintain IAQ. Further, trend logging and dynamic displays can allow the designer and operator to analyze the building performance historically or in real-time. And a real-time predictive maintenance program with status inputs such as filter and drain pan alarms can be used to prevent degradation of air quality.

Dynamic graphical operator interfaces providing intuitive “snapshot” system displays, three dimensional multipoint dynamic and historical plots, and live video displays of critical systems are available for a BMS and can be employed in IAQ application. When these functions are specified, the operator’s value is greatly enhanced by a better understanding of the HVAC system operation and by real time feedback to adjustments that are made.

For additional information on system configuration, network communications, and specifying graphics, refer to the Building Management System Fundamentals section.

GRAPHIC DISPLAYS

Figure 7 provides a sample of an operator graphic showing the functional software relationships that control the system. Actual values for the temperatures, air flows, and valve and damper positions and percent fan loads are all shown for the operator. In addition, the control and logic functions that control the system are shown. The rectangle in the lower right corner is a set of selection buttons which allow the operator to look at additional data. Clicking on one of the buttons produces an operator display similar to Figure 8.

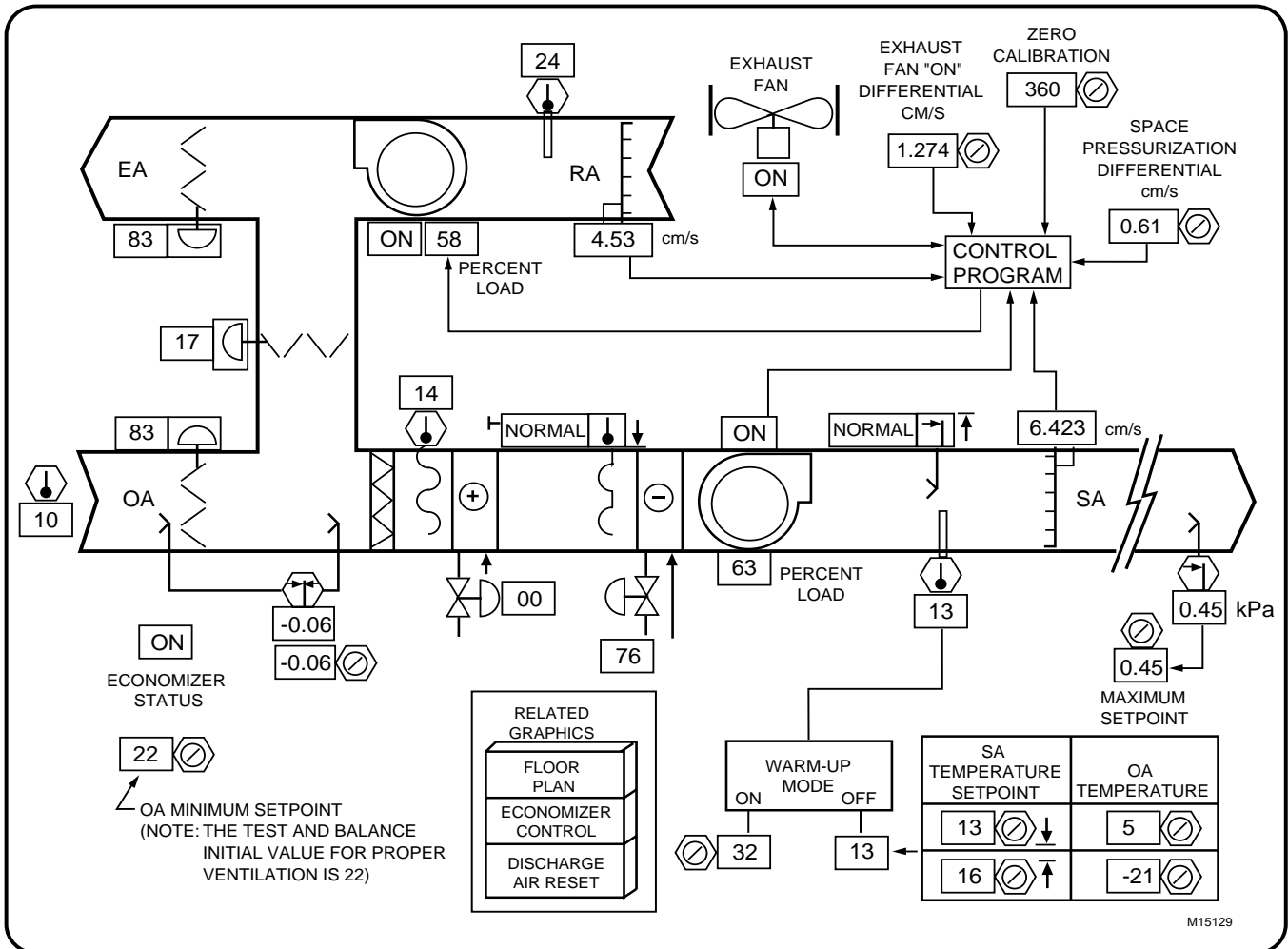
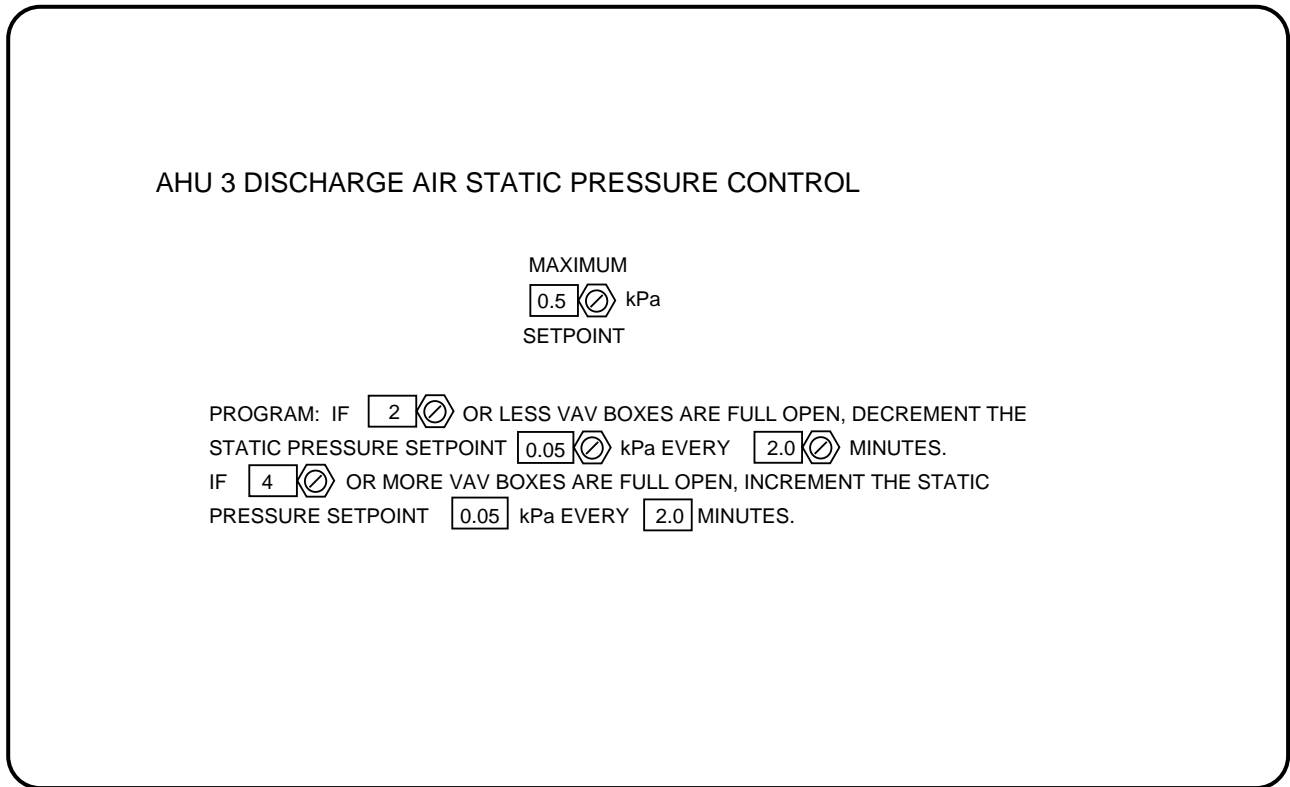

Fig. 7. Sample Minimum Operator Graphic Display.

Figure 8 shows how dynamic data can assist an operator. This display provides the operator/engineer with the actual operating values, at that instant, embedded in the sequence of operations

and allows the operator to adjust setpoints and review results in real time. This is one of many operator displays that can be designed to facilitate operator understanding and control of IAQ.



M15128

Fig. 8 Operator Graphic with Dynamic Data embedded in the Text Sequence.

A graphic such as Figure 9 can be automatically displayed as an alarm on a quarterly calendar basis to remind the building operators and owners that the maintenance of IAQ is one of their

responsibilities. The acknowledgment of the alarm provides the necessary closure of the loop from the designer to the user. Alarm acknowledgment can be logged by the owner to verify compliance.



Fig. 9. IAQ Documentation Graphic.

BIBLIOGRAPHY

REFERENCED PUBLICATIONS

1. ASHRAE 62-1989 Ventilation For Acceptable Indoor Air Quality
2. ASHRAE 55-1992 Thermal Environmental Conditions for Human Comfort
3. ASHRAE Guideline 1-1989 Guideline for Commissioning of HVAC Systems
4. ASHRAE Fundamental Handbook 1997
5. EPA National Ambient Air Quality standard
6. National Plumbing Code
7. National Mechanical Code
8. Uniform Mechanical Code
9. BOCA Mechanical Code

10. Southern Mechanical Code
11. OSHA Standards
12. NIOSH IDLH Listing

RELATED PUBLICATIONS

1. HRA 84-14,500 Guideline for Construction and Equipment of Hospital and Medical Facilities
2. SMACNA HVAC Systems Commissioning Manual
3. SMACNA HVAC Systems—Testing, Adjusting and Balancing
4. SMACNA IAQ Guidelines for Occupied Buildings Under Construction
5. SMACNA Indoor Air Quality

Smoke Management Fundamentals

ENGINEERING MANUAL OF AUTOMATIC CONTROL

CONTENTS

Introduction	172
Definitions	172
Objectives	173
Design Considerations	173
General	173
Layout of System	174
Codes and Standards	174
Design Principles	175
Causes of Smoke Movement	175
Stack Effect	175
Buoyancy	175
Expansion	176
Wind Velocity	176
HVAC	177
Control of Smoke	177
Pressurization	177
Airflow	178
Purging	178
Control Applications	178
Zone Pressurization Control	179
Stairwell Pressurization Control	180
Control of Malls, Atria, and Large Areas	181
Acceptance Testing	181
Leakage Rated Dampers	181
Bibliography	182
Referenced Publications	182
Additional Related Publications	182

INTRODUCTION

This section describes objectives, design considerations, design principles, control applications, and acceptance testing for smoke management systems. A smoke management system modifies the movement of smoke in ways to provide safety for the occupants of a building, aid firefighters, and reduce property damage. References are at the end of this section which include smoke control codes.

Smoke is a highly toxic agent. Information from U.S. Fire Administration estimates that in 1989 approximately 6,000 fire fatalities occurred in the United States, and 80 percent of these deaths were from inhalation of smoke. Furthermore, an additional 100,000 individuals were injured, and fire damage exceeded \$10,000,000,000.

Long term effects on humans from repeated exposure to smoke and heat is a major concern. According to the National Institute of Building Sciences, "The significance of time of human exposure is the fact that brief exposure to a highly toxic environment may be survived, while a lengthy exposure to a moderately toxic environment can lead to incapacitation, narcosis, or death."¹ The primary toxic agent produced in

building fires is carbon monoxide. Other toxic agents include hydrogen cyanide, hydrogen chloride, sulphur dioxide, acrolein, aldehydes, carbon dioxide, and a variety of airborne particulates carrying heavy metals (antimony, zinc, chromium, and lead).

Early smoke management systems used the concept of passive control to limit the spread of fire and smoke. This method evolved from early fire containment methods used in high rise buildings. With passive control, HVAC fans were shut down and dampers were used to prevent smoke from spreading through ductwork. This application required very-low-leakage dampers. Fire walls or barriers, used to prevent the spread of fire, were enhanced to prevent the spread of smoke.

In the late 1960s, the concept of active smoke control was created. With active control, the HVAC fans activate to prevent smoke migration to areas outside of fire zones. This method includes pressurized stairwells and a technique sometimes called the pressure sandwich or zoning in which the floors adjacent to the fire floor are pressurized and the fire floor is exhausted.

DEFINITIONS

AHJ: Authority Having Jurisdiction. (There may be more than one authority.)

ASHRAE: American Society of Heating, Refrigerating and Air-Conditioning Engineers, Inc.

Atrium: A large volume space within a floor opening or series of floor openings connecting two or more stories, covered at the top of the series of openings, and used for purposes other than an enclosed stairway, elevator hoistway, escalator opening, or utility shaft.

Buoyancy: The tendency of warmer air or smoke to rise when located in cooler surrounding air. Caused by the warmer air being less dense than the cooler air, resulting in pressure differences.

Combination fire and smoke damper: A device that resists the passage of air, fire, and smoke and meets the requirements of UL 555, Standard for Fire Dampers, and UL 555S, Standard for Leakage Rated Dampers for Use In Smoke Control Systems.

Covered mall: A large volume space created by a roofed-over common pedestrian area, in a building, enclosing a number of tenants and occupancies such as retail stores, drinking establishments, entertainment and amusement facilities, and offices. Tenant spaces open onto, or directly communicate with, the pedestrian area.

Expansion: The increase in the volume of smoke and gas caused by the energy released from a fire.

Fire damper: A damper that meets the requirements of UL 555, Standard for Fire Dampers, and resists the passage of air or fire.

FSCS: Firefighters' Smoke Control Station.

Large volume space: An unpartitioned space, generally two or more stories in height, within which smoke from a fire, either in the space or in a communicating space, can move and accumulate without restriction. Atria and covered malls are examples of large volume spaces.

NFPA: National Fire Protection Association.

Pressure sandwich: An application where only the zones adjacent to a smoke zone are pressurized and the fire zone is exhausted to limit the spread of smoke.

Smoke: The airborne solid and liquid particulates and gases developed when a material undergoes pyrolysis or combustion, together with the quantity of air that is entrained or otherwise mixed into the mass.

Smoke Control System: A system that modifies the movement of smoke in ways to provide safety for the occupants of a building, aid firefighters, and reduce property damage.

Smoke Management System, Active: A system that uses fans to produce airflows and pressure differences across smoke barriers to limit and direct smoke movement.

Smoke Management System, Passive: A system that shuts down fans and closes dampers to limit the spread of fire and smoke.

Smoke Control Zone: An indoor space enclosed by smoke barriers, including the top and bottom, that is part of a zoned smoke control system (NFPA 92A).

Smoke Damper: A device designed to resist the passage of air or smoke that meets the requirements of UL 555S, Standard for Leakage Rated Dampers for Use In Smoke Control Systems.

Stack Effect: A movement of air or other gas in a vertical enclosure induced by a difference in density between the air or other gas in the enclosure and the ambient atmosphere. The density difference is caused by temperature-pressure differences between the air inside a building and the air outside a building. The air inside the building moves upwards or downwards depending on whether the air is warmer or colder, respectively, than the air outside.

UL: Underwriter’s Laboratories Inc.

UPS: Uninterruptible Power Supply.

OBJECTIVES

Designing a smoke management system requires agreement on the system objectives. The following is a partial list of potential system objectives:

- Provide safety for the occupants
- Extend egress time
- Provide safe egress route

- Provide safe zones (tenable environment)
- Assist firefighters
- Limit property damage
- Limit spread of smoke away from fire area
- Clear smoke away for visibility
- Provide elevator usage during fires as an egress route for the handicapped

DESIGN CONSIDERATIONS

GENERAL

Four points must be stressed in developing a smoke management system:

1. The smoke management system can be properly designed only with agreement on the objectives of the system.
2. The smoke management system must be designed as a complete mechanical control system that is able to function satisfactorily in the smoke management mode. The smoke management system should be designed independently of the HVAC system and then integrated, where feasible, without sacrificing functionality of the smoke control system.
3. The smoke management system must be designed to be reliable, simple, and maintainable.
4. The smoke management system must be designed to minimize the risks of failure and must be tested periodically. Sensors providing status of operation and building automation controls providing system monitoring and printed records can assist in the testing process.

Present active smoke control systems use active methods and follow two basic design approaches to preventing the movement of smoke from the fire zone:

- Providing static pressure differences across penetrations in smoke barriers, such as cracks around doors.
- Providing adequate velocity of air through large openings in smoke barriers, such as doors in an open position.

Although these two methods are directly related, it is more practical to use one or the other to design with and measure the results.

Methods used to activate smoke control systems require careful consideration. For zoned smoke control, care must be taken in using smoke detectors to initiate a pressurization strategy. If a smoke detector that is not in the smoke zone goes into alarm, the wrong smoke control strategy will be employed. If a pull station is activated from a nonsmoke zone, the wrong smoke control strategy could again be employed.

Any alarm activation of a smoke management system that is common to all strategies in the building, such as stairwell pressurization, atria, and exhaust, is acceptable.

For a smoke management system to function reliably, building leakage must be controlled during and after construction. Any penetrations of smoke barriers and walls used for pressurization must be carefully considered in order to maintain the intended smoke control.

Smoke management typically includes control of fires by automatic sprinklers. Designing smoke management systems for sprinklered buildings is quite practical. However, designing smoke management systems for buildings that do not have sprinkler systems is extremely difficult. Complicating the design task are problems with estimating the fire size and dealing with higher static pressures (or airflows).

Smoke vents and smoke shafts are also commonly used as a part of the smoke management system to vent pressures and smoke from fire areas; however, their effectiveness depends on the nearness of the fire, the buoyancy of the smoke, and other forces driving the smoke.

LAYOUT OF SYSTEM

Smoke management equipment should be located in a building where it can best facilitate smoke control for various building layouts. The following guidelines apply:

- Follow the drawings and specifications for the job.
- Locate the smoke controls near the mechanical equipment used to control the smoke.
- Try to minimize the length of runs for sensors, actuators, power, and communications wiring in order to reduce the possibility of wiring being exposed to areas where there might be a fire.

Appendix A of NFPA 92A describes an example of a Firefighters' Smoke Control Station (FSCS). The FSCS allows firefighters to have control capability over the smoke control equipment within the building. The FSCS must be able to show clearly if the smoke control equipment is in the normal mode or the smoke control mode. The example in NFPA 92A includes location, access, physical arrangement, control capability, response time, and graphic depiction. This example is for information only and is not a requirement.

CODES AND STANDARDS

The integration of fire alarm and smoke control is covered in UL 864, Standard for Control Units for Fire-Protective Signaling Systems. Compliance with this UL standard for engineered smoke control systems requires the following:

- Compliance with NFPA 92A, Recommended Practice for Smoke Control Systems
- End-of-process verification of each control sequence
- Annunciation of any failure to confirm equipment operation
- Automatic testing of dedicated smoke control systems

Controls that meet UL Standard 864 are listed under UL Category UUKL. Standby power and electrical supervision items listed in UL864 are optional for smoke control systems.

According to NFPA 92A, control sequences should allow smoke control modes to have the highest priority; however, some control functions should not be overridden. Examples of these functions are duct-static high pressure limit control (use a modulating limit control, if a concern) and shutdown of the supply fan on detection of smoke in a supply air duct.

Manual override of automatic smoke control systems should be permitted. In the event of multiple alarm signals, the system should respond to the first set of alarm conditions unless manually overridden.

All related energy management functions should be overridden when any smoke control mode is activated by an actual alarm or during the testing process.

During the planning stage of a project, design criteria should include a procedure for acceptance testing. NFPA 92A states that, "Contract documents should include operational and acceptance testing procedures so that all parties—designer, installers, owner, and authority having jurisdiction—have a clear understanding of the system objectives and the testing procedure."² ASHRAE 5-1994 Commissioning Smoke Management Systems is intended to ensure proper operation.

Legal authority for approval of smoke control systems is from the Authority Having Jurisdiction (AHJ). The AHJ uses local building codes as its primary standard. Local building codes are established using several reference standards or codes including the following:

- Model Building Codes:
 - Building Officials and Code Administrators International (BOCA), Inc.
 - International Conference of Building Officials (ICBO)
 - Southern Building Code Congress, Inc. (SBCCI)
 - Western Fire Chiefs Association (WFCA)
 - National Mechanical Code (NMC)
 - American with Disabilities Act (ADA)
- National Fire Protection Association (NFPA) Standards:
 - NFPA 92A, Recommended Practice for Smoke Control Systems
 - NFPA 92B, Guide for Smoke Management Systems in Malls, Atria, and Large Areas
 - NFPA 90A, Installation of Air Conditioning Systems
- Underwriters Laboratories (UL) Standards:
 - UL 555, Standard for Fire Dampers and Ceiling Dampers
 - UL 555S, Standard for Leakage Rated Dampers for Use In Smoke Control Systems
 - UL 864, Standard for Control Units for Fire-Protective Signaling Systems (UL Category UUKL)

DESIGN PRINCIPLES

CAUSES OF SMOKE MOVEMENT

The movement or flow of smoke in a building is caused by a combination of stack effect, buoyancy, expansion, wind velocity, and the HVAC system. See Figure 1. These items basically cause pressure differences resulting in movement of the air and smoke in a building.

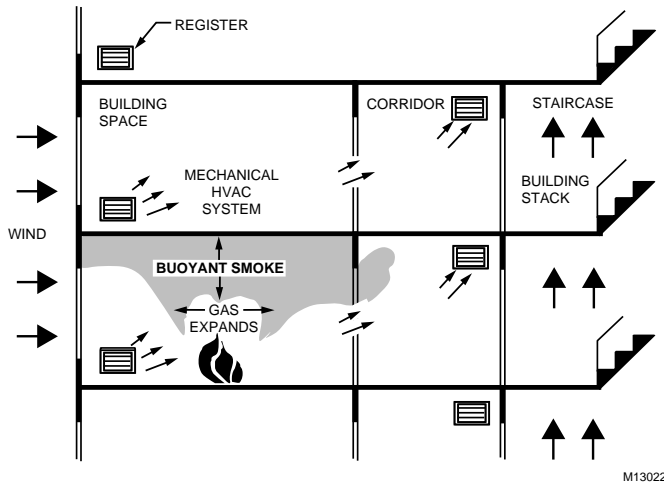

Fig. 1. Factors Affecting the Movement of Smoke.

Before controls can be applied, it is necessary to first understand the overall movement of smoke.

STACK EFFECT

Stack effect is caused by the indoor and outdoor air temperature differences. The temperature difference causes a difference in the density of the air inside and outside of the building. This creates a pressure difference which can cause a vertical movement of the air within the building. This phenomenon is called stack effect. The air can move through elevator shafts, stairwells, mechanical shafts, and other vertical openings. The temperature-pressure difference is greater for fire-heated air which may containing smoke than it is for normal conditioned air. For further information on stack effect refer to the Building Airflow System Control Applications section.

When it is colder outside than inside, there is a movement of air upward within the building. This is called normal stack effect. Stack effect is greater for a tall building than for a low building; however, stack effect can exist in a one-story building. With normal stack effect, air enters the building below the neutral

plane, approximately midheight, and exits above the neutral plane. See Figure 2. Air neither enters nor exits at the neutral plane, a level where the pressures are equal inside and outside the building.

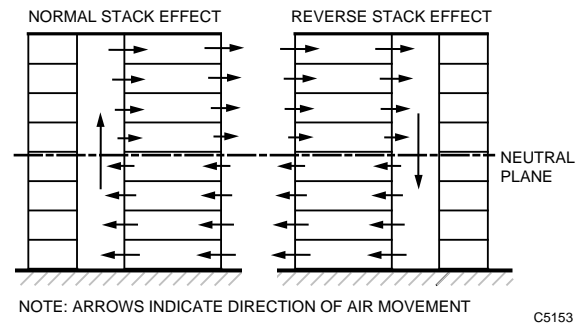

Fig. 2. Smoke Movement Caused by Normal or Reverse Stack Effect.

When it is colder inside than outside, there is a movement of air downward within the building. This is called reverse stack effect. With reverse stack effect, air enters the building above the neutral plane and exits below the neutral plane.

The pressure difference across the building's exterior wall caused by temperature differences (normal or reverse stack effect) according to Design of Smoke Management Systems for Buildings published by ASHRAE is expressed as:³

$$\Delta P = K_S \times \left(\frac{1}{T_O} - \frac{1}{T_I} \right) \times h$$

Where:

- ΔP = Pressure difference, Pa
- K_S = Coefficient, 3460
- T_O = Absolute temperature of outdoor air, Kelvin (K)
- T_I = Absolute temperature of air inside the shaft, Kelvin (K)
- h = Distance from the neutral plane, m

BUOYANCY

Buoyancy is the tendency of warm air or smoke to rise when located in cool surrounding air. Buoyancy occurs because the warmer air is less dense than the cooler air, resulting in pressure differences. Large pressure differences are possible in tall fire compartments.

The buoyancy effect can cause smoke movement through barriers above the fire and through leakage paths in walls. However, as smoke moves away from the fire, its temperature is lowered due to heat transfer and dilution; therefore, the effect of buoyancy decreases with distance from the fire.

The pressure difference between a fire zone and the zone above can be expressed as:³

$$\Delta P = K_s \times \left(\frac{1}{T_o} - \frac{1}{T_f} \right) \times h$$

Where:

- ΔP = Pressure difference, Pa
- K_s = Coefficient, 3460
- T_o = Absolute temperature of surrounding air, Kelvin (K)
- T_f = Absolute temperature of the fire compartment, Kelvin (K)
- h = Distance from the neutral plane, m

EXPANSION

The energy released by fire can move smoke by expansion of hot gas caused by the fire. A fire increases the volume of the heated gas and smoke and causes pressure in the fire compartment. If there are several openings, the pressure differences are small.

The volumetric flow of smoke out of a fire zone is greater than the airflow into the fire zone. This situation is expressed as:³

$$\frac{Q_{out}}{Q_{in}} = \frac{T_{out}}{T_{in}}$$

Where:

- Q_{out} = Volumetric flow rate of smoke out of the fire compartment, m³/s
- Q_{in} = Volumetric flow rate of air into the fire compartment, m³/s
- T_{out} = Absolute temperature of smoke leaving the fire compartment, Kelvin (K)
- T_{in} = Absolute temperature of air into the fire compartment, Kelvin (K)

For tightly sealed fire zones, the pressure differences across the barrier caused by expansion can be extremely important. Venting or relieving of pressures created by expansion is critical to smoke control. Venting is often accomplished with smoke vents and smoke shafts.

The relationship between volumetric airflow (smoke) and pressure through small openings, such as cracks, is as:³

$$\Delta P = \left(\frac{Q}{K_f A} \right)^2$$

Where:

- ΔP = Pressure difference across the flow path, Pa
- Q = Volumetric flow rate, m³/s
- K_f = Coefficient, 0.839
- A = Flow area, sq m

WIND VELOCITY

Wind velocity can have a significant effect on the movement of smoke within a building. The infiltration and exfiltration of outdoor air caused by wind can cause the smoke to move to areas other than the fire compartment. Positive pressures on the windward side cause infiltration; negative pressures on the leeward side cause exfiltration. The higher the wind velocity, the greater the pressure on the side of the building. In general, wind velocity increases with the height from the ground. The effects of wind on a tightly constructed building can be negligible. However, the effects can be significant for loosely constructed buildings or buildings with open doors or windows.

If a window breaks on the windward side of a building because of a fire, smoke can be forced from the fire compartment to other areas of the building, endangering lives and dominating air movement. If a window breaks on the leeward side, the wind can help to vent the smoke from the fire compartment to the outside.

$$P_w = C_w \times K_w \times V^2$$

The pressure caused by wind on a building surface is expressed as:³

Where:

- P_w = Wind pressure, Pa
- C_w = Dimensionless pressure coefficient
- K_w = Coefficient, 0.6
- V = Wind velocity, m/s

The pressure coefficient, C_w , varies greatly depending on the geometry of the building and can vary over the surface of the wall. Values range from -0.8 to 0.8, with positive values for windward walls and negative values for leeward walls.

HVAC

HVAC systems can provide a means for smoke transport even when the system is shut down (e.g., a bypass damper venting smoke). Utilizing the HVAC system in smoke control strategies can offer an economic means of control and even meet the need for zone pressurization (e.g., pressurizing areas adjacent to a fire compartment).

CONTROL OF SMOKE

Smoke control uses barriers within the building along with airflow produced by mechanical fans to contain the smoke. For some areas, the pressure difference across the barrier can be used to control the smoke. Where the barriers have large penetrations, such as door openings, it is easier to design and measure the control system results by using airflow methods. Both methods, pressurization and airflow, are discussed in the following paragraphs.

In addition to life safety requirements, smoke control systems should be designed to provide a path to exhaust the smoke to the outdoors, thereby relieving the building of some of the heat of the fire and the pressure of the gas expansion.

PRESSURIZATION

Pressurization of nonsmoke areas can be used to contain smoke in a fire or smoke zone. Barriers are required between the nonsmoke areas and the area(s) containing the smoke and fire. For the barrier to perform correctly in a smoke control system, a static pressure difference is required across any penetrations or cracks to prevent the movement of smoke. Figure 3 illustrates such an arrangement with a door in a wall. The high pressure side can act as a refuge or an escape route, the low pressure side as a containment area. The high pressure prevents any of the smoke from infiltrating into the high pressure area.

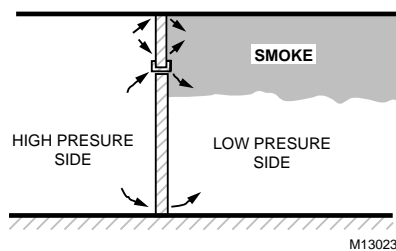

Fig. 3. Pressurization Used to Prevent Smoke Infiltration.

Guidelines for pressurization values are found in NFPA 92A, Recommended Practice for Smoke Control Systems. Table 1 indicates minimum design pressure differences across smoke barriers. The design pressure difference listed is the pressure difference between the smoke zone and adjacent spaces while the affected areas are in the smoke control mode. The smoke control system should be able to maintain these minimum

pressure differences while the building is under typical conditions of stack effect and wind. This table is for gas temperatures of 927°C adjacent to the barrier. To calculate pressure differences for gas temperatures other than 927°C, refer to data in NFPA 92A.

Table 1. Suggested Minimum Design Pressure Differences Across Smoke Barriers.

Building Type	Ceiling Height (m)	Design Pressure Difference (Pa)
Sprinklered	Unlimited	12.5
Nonsprinklered	2.7	24.9
Nonsprinklered	4.6	34.9
Nonsprinklered	6.4	44.8

Pressure differences can vary because of fan pulsations, wind, and doors opening and closing. Short-term variances, from the suggested minimum design pressure differences in Table 1, do not seem to have significant effects on the protection furnished by a smoke control system. There is no actual definitive value for short-term variances. The value depends on the tightness of the construction and the doors, the toxicity of the smoke, the airflow rates, and the volume of the protected space. Occasional variances of up to 50 percent of the maximum design pressure difference can be allowed in most cases.

Table 2 lists values for the maximum pressure differences across doors. These values should not be exceeded so that the doors can be used when the pressurization system is in operation. Many door closers require less force when the door is initially opened than the force required to open the door fully. The sum of the door closer force and the pressure imposed on the door by the pressurization system combine only until the door is opened sufficiently to allow air to move easily through the door. The force imposed by a door closing device on closing a door is often different from that imposed on opening a door.

Table 2. Maximum Pressure Difference Across Doors in Pa (NFPA 92/92A).

Door Closer Force (N)	Door Width (m)				
	0.813	0.914	1.02	1.12	1.17
26.7	112	100	92.1	84.6	77.2
35.6	102	92.1	84.5	77.1	69.7
44.5	92.1	84.5	74.6	69.7	64.8
53.4	84.5	74.6	67.2	62.2	57.3
62.3	74.6	67.2	59.7	45.7	523.3

NOTE: Total door opening force is 133N. Door height is 2.13m. The distance from the doorknob to the knob side of the door is 0.076m. (ADA has requirements which conflict with this table.)

The door widths in Table 2 apply only for doors that are hinged at one side. For other arrangements, door sizes, or for hardware other than knobs (e.g., panic hardware), refer to calculation procedures furnished in Design of Smoke Control Systems for Buildings published by ASHRAE³.

AIRFLOW

is most commonly used to stop smoke movement through open doorways and corridors. Figure 4 illustrates a system with relatively high velocity to prevent backflow of smoke through an open doorway. Figure 5 illustrates a system with relatively low velocity which allows backflow of smoke. The magnitude of the velocity of the airflow required to prevent backflow depends on the energy release rate of the fire. Since this can vary, the velocity should be regulated to prevent oxygen from being fed to the fire. The fact that doors are sometimes left open during evacuation of a building, allowing smoke to flow through, should be taken into account in designing the smoke control system. This is done by designing and testing the system with one or more doors open.

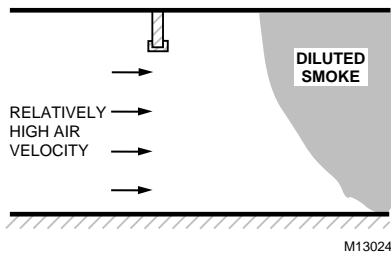

Fig. 4. High Air Velocity Preventing Backflow of Smoke Through an Open Doorway.

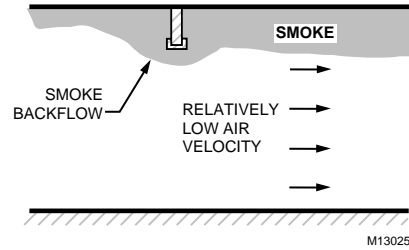

Fig. 5. Low Air Velocity Allowing Backflow of Smoke through an Open Doorway.

PURGING

Because fires produce large quantities of smoke, purging cannot ensure breathable air in a space while a fire is in progress. After a fire, purging is necessary to allow firefighters to verify that the fire is totally extinguished. Traditionally, firefighters have opened doors and windows to purge an area. Where this is not possible, the HVAC system can be designed to have a purge mode.

The principle of dilution can be applied to zones where smoke has entered and is being purged. Purging dilutes the contaminated air and can continue until the level of obscuration is reduced and the space is reasonably safe to enter. The following equation allows determining a concentration of contaminant in a compartment after purging for a given length of time:³

$$C = C_0 \times e^{-at}$$

Where:

- C = concentration of contaminant at time, t
- C₀ = initial concentration of contaminant
- a = purging rate in number of air changes per minute
- t = time after doors close in minutes
- e = constant, approximately 2.718

Care must be taken in the use of this equation because of the nonuniformity of the smoke. Buoyancy is likely to cause greater concentration of smoke near the ceiling. Therefore, consideration of the locations of supply and exhaust registers is important to effective purging.

CONTROL APPLICATIONS

Figure 6 illustrates a smoke control system with detectors, an initiating panel, and a communications bus to an alarm processor and remote control panels in appropriate areas of the building. A configuration similar to this will meet the requirements of UL 864, Standard for Control Units for Fire-Protective Signalling Systems, and comply with NFPA 92A recommended practice for smoke control systems. The remote control panels position dampers and operate fans to contain or

exhaust smoke, depending on the requirements of the various areas in the building. The system can have an operator’s control console for the building personnel and an FSCS from which to view the status of and override the smoke control system. The system requires a means of verifying operation, such as differential pressure or airflow proving devices, for each control sequence. An uninterruptible power supply (UPS) is optional but recommended.

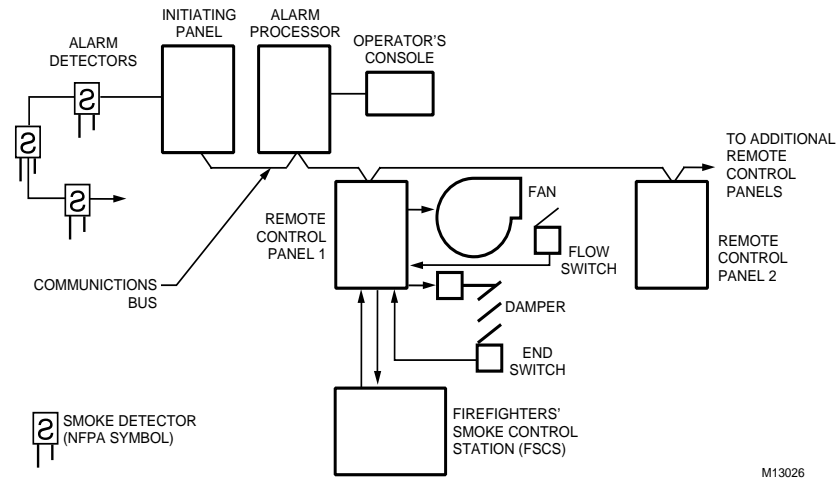

Fig. 6. Typical Smoke Control System Meeting the Requirements of UL Standard 864 and NFPA 92A.

The following discussions cover smoke control applications for building zones, stairwells, and large areas including malls and atria. Each of these discussions conclude with a typical operational sequence complying with UL Standard 864 for the smoke control system illustrated in Figure 6.

than one floor. In Figure 7E, the smoke zone is only a part of a floor and all the rest of the building areas are pressurized. Smoke zones should be kept as small as reasonable so control response can be readily achieved and quantities of air delivered to the nonsmoke zones can be held to manageable levels.

Products utilized in smoke control and management systems should be UL labeled for the following applications:

- DDC Panels: Smoke Control Equipment.
- Building Management System/Fire Control System: Critical Process Management, Smoke Control, or Fire Control Unit Equipment

ZONE PRESSURIZATION CONTROL

The objective of zone pressurization is to limit the movement of smoke outside the fire or the smoke control zone by providing higher pressure areas adjacent to the smoke zone. Zone pressurization can be accomplished by:

- Providing supply air to adjacent zones
- Shutting off all returns or exhausts to floors other than the fire floor
- Exhausting the smoke zone (also aids stairwell pressurization systems by minimizing buoyancy and expansion effects)
- Shutting off, providing supply air to, or leaving under temperature control all supplies other than those adjacent to the fire floor

A smoke control zone can consist of one or more floors or a portion of a floor. Figure 7 illustrates typical arrangements of smoke control zones. The minus sign indicates the smoke zone. The plus signs indicate pressurized nonsmoke zones. In the event of a fire, the doors are closed to the fire or smoke control zone and the adjacent zones are pressurized. In the example in Figures 7A and 7B, the floors above and below the smoke zone are pressurized. The application in Figure 7B is called a pressure sandwich. In Figures 7C and 7D, the smoke zone consists of more

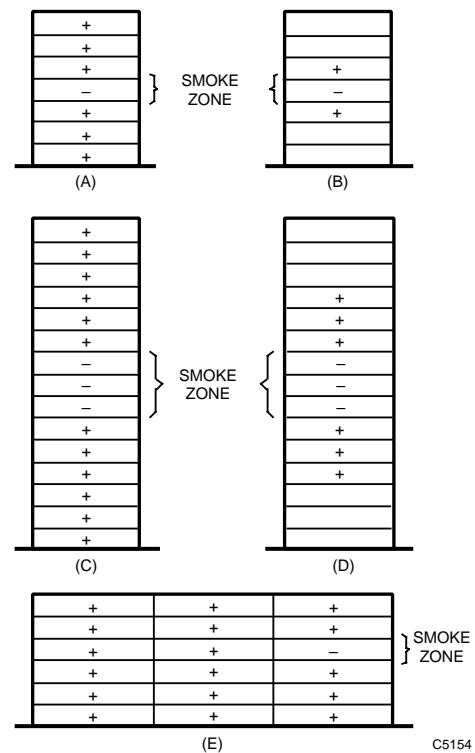

Fig. 7. Typical Zone Pressurization Arrangements for Smoke Control Zones.

The practice of exhausting air as a means of providing higher pressure areas adjacent to the smoke zone should be examined carefully. Exhausting air from the fire floor may tend to pull the fire along and cause flames to spread before they can be extinguished.

Another consideration in zone pressurization is that bringing in outdoor air at low temperatures can cause serious freeze damage. Provision should be made to prevent damage when using outdoor air, such as providing emergency preheat and minimizing the quantity of outdoor air used.

Testing of smoke control strategies should include not only verification of acceptable pressures but also confirmation that interaction with other systems creates no problems, such as excessive door pull in a stairwell pressurization system (refer to American with Disabilities Act).

Typical Operation for Zone Pressurization System (Fig. 6):

1. Smoke detector(s) initiate alarm in specific zone.
2. System switches to smoke control mode as determined in remote control panel.
3. System turns on pressurization fans if not already on.
4. System allows pressurization fans to continue running if supply duct smoke detector is not in alarm or manual override is not activated.
5. System enables damper operation as appropriate for smoke control mode.
6. Operator verifies operation as appropriate (e.g., action of differential pressure switch).
7. Operator cancels smoke control mode as long as initiating panel is not in alarm and FSCS is not in manual override.

STAIRWELL PRESSURIZATION CONTROL

The objective of stairwell pressurization is to provide an acceptable environment within a stairwell, in the event of a fire, to furnish an egress route for occupants and a staging area for firefighters. On the fire floor, a pressure difference must be maintained across the closed stair tower door to ensure that smoke infiltration is limited. Also, adequate purging must be provided to limit smoke density caused by temporary door openings on the fire floor.

To ensure proper stairwell pressurization system design, a means should be included to modulate either the supply or the exhaust/relief dampers. Also, a means should be included to provide multiple supply injection points at a minimum of every three floors (unless design analysis can justify a greater spacing) to provide uniform pressurization.

According to NFPA 92A, Recommended Practice for Smoke Control Systems, the intake of supply air should be isolated from smoke shafts, roof smoke and heat vents, and other building openings that might expel smoke from the building in a fire. Wind shields should be considered at fan intakes.

Open-loop control of pressurization is seldom acceptable because of significant pressure differences caused by door openings. Closed loop or modulation provides the ability to control pressurization within acceptable limits. Closed loop control can be as simple as a barometric pressure damper (Fig. 8) to relieve pressure at the top of a stairwell or a more

complex system to modulate dampers or fans at multiple injection points (Fig. 9) in response to differential pressure measurements at these points.

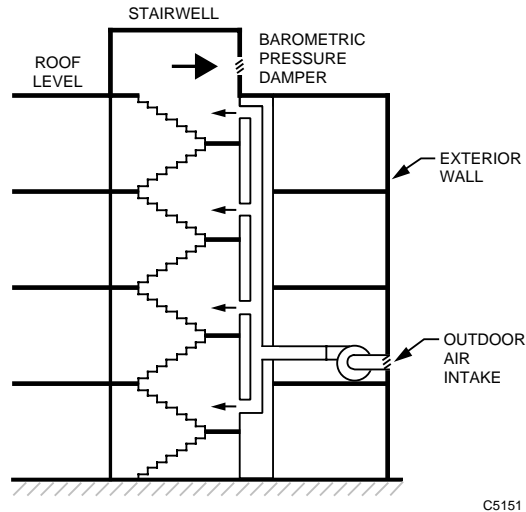

Fig. 8. Stairwell Pressurization with Barometric Pressure Damper to Vent to the Outside.

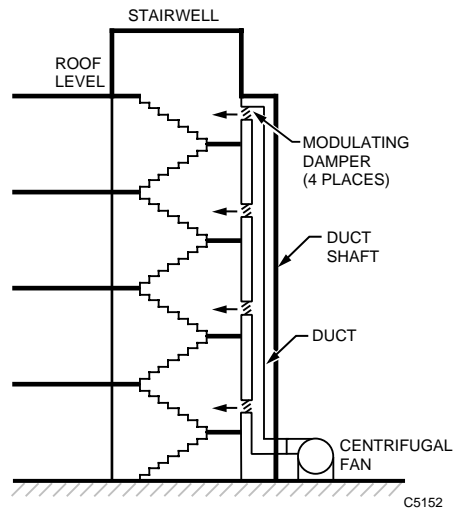

Fig. 9. Stairwell Pressurization with Modulating Dampers and Multiple Injection Points to Regulate Pressure.

Testing of stairwell pressurization systems should be conducted with agreed on conditions including:

- Number and location of doors held open
- Outside pressure conditions known
- Maximum door pull force allowed

Typical Operation for Stairwell Pressurization (Fig. 6):

1. Any fire alarm initiates smoke control mode.
2. System turns on pressurization fans.
3. System allows pressurization fans to continue running if supply duct smoke detector is not in alarm or manual override is not activated.

4. System enables damper operation as appropriate for smoke control mode.
5. Operator verifies operation as appropriate (e.g., action of differential pressure switch).
6. Operator cancels smoke control mode as long as initiating panel is not in alarm and FSCS is not in manual override.

CONTROL OF MALLS, ATRIA, AND LARGE AREAS

The objective of malls, atria, and other large area smoke control systems is to prevent the area from filling with smoke as a result of fire in the area or an adjoining area. Purging is used as the means to dilute and remove smoke.

In large areas (Fig. 10), the smoke produced is buoyant and rises in a plume until it strikes the ceiling or stratifies because of temperature inversion. The smoke layer then tends to descend as the plume continues to supply smoke. Smoke can be exhausted to delay the rate of descent of the smoke layer. Also, sprinklers can reduce the heat release rate and the smoke entering the plume. Adjacent spaces to the mall or atrium can be protected from the smoke by barriers or opposed airflow.

Additional information can be found in NFPA 92B, Guide for Smoke Management in Malls, Atria, and Large Areas.

Typical Operation for Smoke Control Systems for Malls, Atria, and Other Large Areas (Fig. 6):

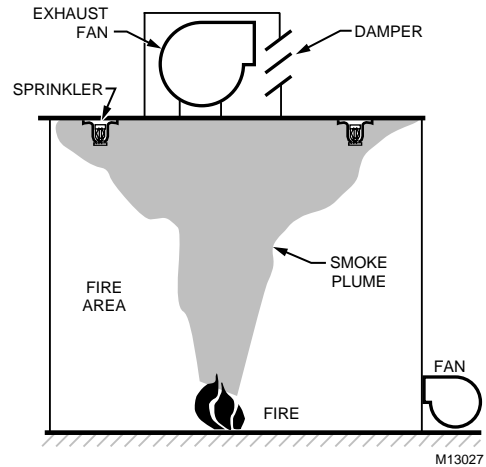

Fig. 10. Control of Smoke in Malls, Atria, and Other Large Areas.

1. Any fire alarm initiates smoke control mode.
2. System turns on exhaust fans.
3. System enables damper operation as appropriate for smoke control mode.
4. Operator verifies operation as appropriate (e.g., action of airflow-proving sail switch).
5. Operator cancels smoke control mode as long as initiating panel is not in alarm and FSCS is not in manual override.

ACCEPTANCE TESTING

Smoke control systems must be tested carefully and thoroughly. All measurements should be recorded and saved.

ASHRAE Guideline 5-1994 should be followed.

The system should be activated by an appropriate sensor within the zone (if applicable) and the results should be monitored and recorded.

Where standby power is used, testing should be conducted with both normal power and standby power.

The use of smoke bombs or tracer gas to test smoke control systems is discouraged because they cannot accurately simulate

fire conditions. Smoke bombs and tracer gas lack the buoyant forces caused by heat generated in a fire. These items can be used, however, for identifying leakage paths and leakage areas.

Periodic testing should be conducted in accordance with the following:

- NFPA 90A, Installation of Air Conditioning and Ventilating Systems
- NFPA 92A, Recommended Practice for Smoke Control Systems
- NFPA 92B, Guide for Smoke Management Systems in Malls, Atria, and Large Areas

LEAKAGE RATED DAMPERS

Refer to the Damper Selection and Sizing section for information on leakage rated dampers.

BIBLIOGRAPHY

REFERENCED PUBLICATIONS

1. Toxicity Effects Resulting from Fires in Buildings, State-of-the Art Report, May 16, 1983, National Institute of Building Sciences.
2. NFPA 92A, Recommended Practice for Smoke Control Systems, 1996 Edition.
3. Design of Smoke Management Systems, 1992 Edition, J. H. Klote and James A. Milke; ASHRAE, Inc., and Society of Fire Protection Engineers, Inc.
6. Smoke Control in Fire Safety Design, A. G. Butcher and A. C. Parnell, E. & F. N. Spon Ltd, 11 New Fetter Lane, London EC4P 4EE, 1979.
7. Smoke Control Technology, Code 88146, ASHRAE, 1989.
8. UL 555, Standard for Fire Dampers and Ceiling Dampers, Fifth Edition, 1995 Revision.
9. UL 555S, Standard for Leakage Rated Dampers for Use In Smoke Control Systems, Third Edition, 1996 Revision.

ADDITIONAL RELATED PUBLICATIONS

1. Smoke Management, Chapter 48, ASHRAE 1995 HVAC Applications Handbook.
2. NFPA 72 National Fire Alarm Code, 1996 Edition.
3. NFPA 90A, Installation of Air Conditioning and Ventilating Systems, 1996 Edition.
4. NFPA 92B, Guide for Smoke Management Systems in Malls, Atria, and Large Areas, 1995 Edition.
5. NFPA 101, Life Safety Code, 1994 Edition.
10. UL 864, Standard for Control Units for Fire-Protective Signaling Systems (UL Category UUKL), Eighth Edition, 1996 Revision.
11. ASHRAE Guideline 5-1994, Commissioning Smoke Management Systems, ISSN 1049 894X.
12. NFPA Fire Protection Handbook, 17th Edition, 1991.
13. Smoke Movement and Control in High-Rise Buildings, George T. Tamura, P.E.; NFPA, Quincy Massachusetts, December 1994; Library of Congress 94-069542; NFPA SCHR-94; ISB: 0-87765-401-8.

Building Management System Fundamentals

ENGINEERING MANUAL OF AUTOMATIC CONTROL

CONTENTS

Introduction	184
Definitions	184
Background	185
Energy Management	185
Facilities Management Systems	185
System Configurations	186
Hardware Configuration	186
Zone-Level Controllers	186
System-Level Controllers	187
Operating-Level Processors	187
Management-Level Processors	187
Communications Protocol	187
Peer Communications Protocol	188
Communications Media	188
Twisted Copper Pair	188
Fiber Optic	188
Phone Lines	188
System Functions	189
General	189
Zone-Level Controller Functions	189
System-Level Controller Functions	189
Operations-Level Functions	189
General	189
Hardware	189
Software	189
Standard Software	189
Communications Software	189
Server	190
Security	190
Alarm Processing	190
Reports	190
System Text	190
System Graphics	190
Controller Support	191
Operation	191
Specifying graphics (I/O summaries)	193
Control graphics	195
Data Penetration	195
Integration of Other Systems	196
General	196
Surface Integration	196
In-Depth Integration	196

INTRODUCTION

This section provides information on the fundamentals of Building Management Systems (BMS). The objective of a BMS is to centralize and simplify the monitoring, operation, and management of a building or buildings. This is done to achieve more efficient building operation at reduced labor and energy costs and provide a safe and more comfortable working environment for building occupants. In the process of meeting these objectives, the BMS has evolved from simple supervisory control to totally integrated computerized control. Some of the advantages of a BMS are as follows:

- Simpler operation with routine and repetitive functions programmed for automatic operation
- Reduced operator training time through on-screen instructions and supporting graphic displays
- Faster and better responsiveness to occupant needs and trouble conditions
- Reduced energy cost through centralized management of control and energy management programs
- Better management of the facility through historical records, maintenance management programs, and automatic alarm reporting
- Flexibility of programming for facility needs, size, organization, and expansion requirements

- Improved operating-cost record keeping for allocating to cost centers and/or charging individual occupants
- Improved operation through software and hardware integration of multiple subsystems such as direct digital control (DDC), fire alarm, security, access control, or lighting control

When minicomputers and mainframes were the only computers available, the BMS was only used on larger office buildings and college campuses. With the shift to microprocessor-based controllers for DDC, the cost of integrating building management functions into the controller is so small that a BMS is a good investment for commercial buildings of all types and sizes. For additional information on microprocessor-based controllers refer to the Microprocessor Based/DDC Fundamentals. Building Control is discussed further in the Air Handling System Control Applications; the Building Airflow System Control Applications; and the Chiller, Boiler, and Distribution System Control sections.

The examples used throughout this section are typical of what is available and not necessarily representative of any given installation.

DEFINITIONS

Building Control System (BCS): A system that controls the comfort and safety of a buildings assets and environment.

Building Management and Control System (BMCS): An integrated BMS and BCS

Building Management System (BMS): A system which centralizes the monitoring, operations, and management of a building to achieve more efficient operations.

Building Automation and Control Network (BACnet) Protocol: A BMCS communications protocol developed by the American Society of Heating, Refrigerating, and Air Conditioning Engineers (ASHRAE).

Communications Protocol: A set of conventions used to govern the format and content of messages between processors.

Dynamic Display Data: Data displayed on a BMCS work station which periodically updates, such as temperature or ON/OFF status. The data updates automatically at a rate appropriate for the point or it may be updated manually.

Energy Management System (EMS): A system that optimizes the operation, temperatures, and processes of an HVAC system within a building. Except for some early versions, a BCS or BMCS includes all EMS functions.

Hierarchical configuration: A system in which the processors and controllers are arranged in levels or tiers, with each tier having a definite rank or order in accessing and processing data. A typical arrangement includes, in descending order, management-level processors, operations-level processors, system-level controllers, and zone-level controllers.

LonMark™ standard: A communications standard for control networks developed by the Echelon Corporation and the LonMark™ Interoperability Association.

Management-level processor: A PC or minicomputer used by management personnel to collect, store, and process data for reports on energy use, operating costs, and alarm activity. This processor can access points or data in all the lower level processors and controllers. (In most cases a separate, management-level processor is not used. Many of the functions of the management-level processor can be combined into the operations-level processor.)

Operations-level processor: A PC or other device used primarily by building operation personnel for everyday building operations. This processor can access points or data in all the lower level controllers.

System-level controller: A microprocessor-based controller that controls centrally located HVAC equipment such as VAV supply units, built-up air handlers, and central chiller and boiler plants. These controllers typically have an input/output (I/O) device capability, a library of control programs, and may control more than one mechanical system from a single controller. In a BMS, these controllers provide processing of point data for higher level processors and typically include energy management programs.

Zone-level controller: A microprocessor-based controller that controls distributed or unitary HVAC equipment such as VAV terminal units, fan coil units, and heat pumps. These controllers typically have relatively few connected I/O devices, standard control sequences, and are dedicated to specific applications. In a BMS, these controllers provide processing of point data for higher level processors.

BACKGROUND

The BMS concept emerged in the early 1950s and has since changed dramatically both in scope and system configuration. System communications evolved from hardwired (and home-run piping for pneumatic centralization) to multiplexed (shared wiring) to today's two-wire all digital system. The EMS and BMCS evolved from poll-response protocols with central control processors to peer-to-peer protocols with distributed control.

ENERGY MANAGEMENT

Energy management is typically a function of the microprocessor-based DDC controller. Several energy management applications are described in Microprocessor-Based/DDC Fundamentals section. In most mid-sized to large buildings, energy management is an integral part of the BMCS, with optimized control performed at the system level and with management information and user access provided by the BMS host.

Equipment is operated at a minimum cost and temperatures are controlled for maximum efficiency within user-defined comfort boundaries by a network of controllers. Energy strategies are global and network communications are essential. Load leveling and demand control along with starting and loading of central plant based upon the demands of air handling systems require continuous global system coordination.

Energy Management BMS host functions include the following:

- Efficiency monitoring - recording
- Energy usage monitoring - recording
- Energy summaries
 - Energy usage by source and by time period
 - On-times, temperatures, efficiencies by system, building, area

- Curve plots of trends
- Access to energy management strategies for continuous tuning and adapting to changing needs
 - Occupancy schedules
 - Comfort limit temperatures
 - Parametric adjustments (e.g., integral gain) of DDC loops
 - Setpoint adjustments:
 - Duct static pressures
 - Economizer changeover values
 - Water temperatures and schedules
- Modifying and adding DDC programs

Energy Management for buildings preceded DDC by about ten years. These pre-DDC systems were usually a digital architecture consisting of a central computer which contained the monitoring and control strategies and remote data gathering panels (DGPs) which interfaced with local pneumatic, electric, and electronic control systems. The central computer issued optimized start/stop commands and adjusted local loop temperature controllers.

FACILITIES MANAGEMENT SYSTEMS

Facilities management, introduced in the late 1980s, broadened the scope of central control to include the management of a total facility. In an automotive manufacturing plant, for example, production scheduling and monitoring can be included with normal BMS environmental control and monitoring. The production and BMS personnel can have separate distributed systems for control of inputs and outputs, but the systems are able to exchange data to generate management reports. For example, a per-car cost allocation for heating, ventilating, and air conditioning overhead might be necessary management information for final pricing of the product.

Facilities management system configuration must deal with two levels of operation: day-to-day operations and long-range management and planning. Day-to-day operations require a real-time system for constant monitoring and control of the environment and facility. The management and planning level requires data and reports that show long-range trends and progress against operational goals. Therefore, the primary objective of the management and planning level is to collect historical data, process it, and present the data in a usable format.

The development of two-wire transmission systems, PCs for centralized functions, and distributed processors including DDC led to a need to define system configurations. These configurations became based on the needs of the building and the requirements of the management and operating personnel. Typical configurations are discussed in SYSTEM CONFIGURATIONS.

SYSTEM CONFIGURATIONS

A BMS includes the hardware configuration and communication systems needed to access data throughout a building or from remote buildings using leased telephone lines.

ZONE-LEVEL CONTROLLERS

Zone-level controllers are microprocessor-based controllers that provide direct digital control of zone-level equipment, including items such as VAV boxes, heat pumps, single-zone air handlers, and perimeter radiation. Energy management software can also be resident in the zone-level controller. At the zone level, sensors and actuators interface directly with the controlled equipment. A communications bus provides networking of zone-level controllers so that point information can be shared between zone-level controllers and with processors at the system and operation level. Zone-level controllers typically have a port or communications channel for use of a portable terminal during initial setup and subsequent adjustments.

HARDWARE CONFIGURATION

Microprocessor-based controllers have led to a hierarchical configuration in the BMS. Figure 1 shows several levels, or tiers, of processors.

- Management-level processors
- Operations-level processors
- System-level controllers
- Zone-level controllers

The actual levels used in a given system depend on the specific needs of the building or complex of buildings. The zone level may incorporate intelligent, microprocessor-based sensors and actuators. The discussions that follow begin with zone-level controllers.

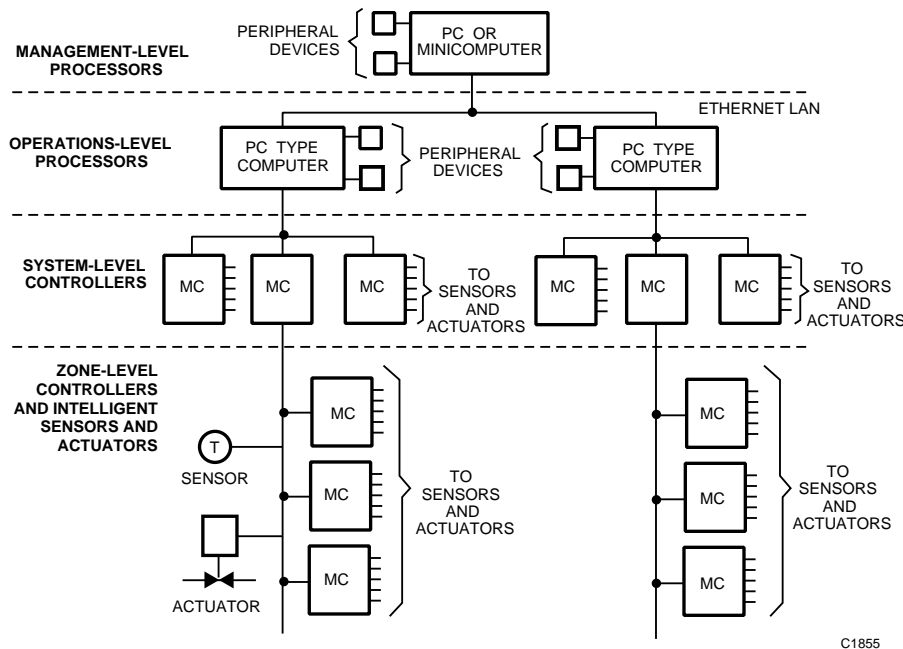

Fig. 1. Hierarchical BMS Configuration.

SYSTEM-LEVEL CONTROLLERS

Microprocessor-based system-level controllers have greater capacity than zone-level controllers in terms of number of points, DDC loops, and control programs. System-level controllers are usually applied to major pieces of mechanical equipment such as large built-up air handlers, central VAV systems, and central chiller plants. These controllers can also perform lighting control functions. Controllers at this level interface with controlled equipment directly through sensors and actuators or indirectly through communications links with zone-level controllers. System-level controllers typically have a port for connecting portable operating and programming terminals during initial setup and subsequent adjustments. When system-level controllers are linked to operations-level processors, subsequent changes to controller programs are normally made at the operations-level processor and then down-line loaded to the controller using the system transmission lines. System-level controllers also provide system survivability by operating in a stand-alone mode should its communication link be lost.

Some types of system-level controllers also provide the property and life-safety protection for the facility through fire alarm panels, security panels, and access control panels. See INTEGRATION OF OTHER SYSTEMS.

OPERATIONS-LEVEL PROCESSORS

Operations-level processors interface primarily with BMCS operating personnel. The processor at this level is in most cases a PC with color operator terminal displays and plug-in function boards to accommodate additional operator terminals, printers, memory expansion, and communications links. An operations-level processor generally includes application software for:

- System security: Limits access and operation to authorized personnel.
- System penetration: Permits authorized personnel to select and retrieve system data via PC keyboard or other selection mechanism.
- Data formatting: Assembles random system points into logical group format for display and printout.
- Data segregation: Groups points by major point types for routing to a specific terminal and specified operator.
- Custom programming: Develops custom DDC programs at the operations level for down-line loading to specific, remote system-level controllers and zone-level controllers. For more information on custom programming see the Microprocessor-Based/DDC Fundamentals section.
- Graphics: Builds custom graphic displays incorporating dynamic system data. Bar chart and curve plot software may be included.

- Standard reports: Provides automatic, scheduled, and by-request reports of alarm and operator activity. Also provides a broad range of system and category (points-in-alarm, disabled points, etc.) summary reports.
- Custom reports: Provides spread sheet, word processing, and a data base management capability.
- Maintenance management: Automatically schedules and generates work orders for equipment maintenance based either on history of equipment run time or on a calendar schedule.
- Site-specific customization: Allows defining operator assignments, peripheral device assignments, printer data segregation, system configuration, display and printout text of action message assignments to specific points, time/holiday scheduling, point monitoring/control, time/event program assignments, and application program parameter assignments.
- System integration: Provides common control and interface for multiple subsystems (HVAC, fire, security, access control) and provides global activity as a result of specific subsystem events (e.g., closing or opening dampers to control smoke as a result of a fire alarm).

MANAGEMENT-LEVEL PROCESSORS

Management-level processors, at the top of the BMCS system hierarchy, exercise control and management over the connected subsystems. An operator at this level can request data from and issue commands to points anywhere in the system (as with most operations-level processors). Day-to-day operation is normally a function of the operations-level processor; however, complete control can be transferred to the management-level processor during emergencies or unattended periods. The management-level processor primarily collects, stores, and processes historical data such as energy use, operating costs, and alarm activity, and generates reports that provide a tool for the long-term management and use of the facility.

COMMUNICATIONS PROTOCOL

Communications protocol is an essential element of the BMCS configuration due to the amount of data transferred from one point to another and because distributed processors may be dependent on each other for data pertinent to resident programs. Communications links, or buses, generally use either a poll/response or a peer protocol. Early BMCSs use poll-response protocols where most system intelligence and data processing was at the central processor. In the mid 1990s most BMCSs use peer protocols which share the communications bus equally among all bus devices with no master device.

PEER COMMUNICATIONS PROTOCOL

Peer communications protocol has the following advantages over poll/response communications protocol:

- Communication not dependent on a single device as the master.
- Direct communication between bus-connected devices without going through the BMS central processor.
- Global messages transmitted to all bus-connected devices.

In peer communications a time slot is automatically passed from one bus-connected device to another as the means of designating when a device has access to the bus. Since the time slot passes in an orderly sequence from one device to the next, the communications network is sometimes termed a ring. However, the bus is not necessarily physically looped nor are the devices physically connected to form a ring. Any device on the bus can be designated as the first to receive the time slot, and any other device the next to receive it, and so on.

COMMUNICATIONS MEDIA

The most common choices for BMS transmission trunks are:

- Twisted copper pairs
- Fiber optic cable
- Common carrier telephone channels

The media best suited for a given installation depends on the signal, cost, geographic layout, and the possibility of line interference.

TWISTED COPPER PAIR

Twisted pair copper conductors ranging from 1.307 to 0.2051 mm² are the most commonly used and the best economic choice as the communications media for single building applications. Bus lengths up to 1200 meters are common without use of extenders or repeaters. When repeaters are used, extensions up to three or four times this distance are possible. Serial bus and star wiring configurations (Fig. 2 and 3) permit efficient wiring layouts.

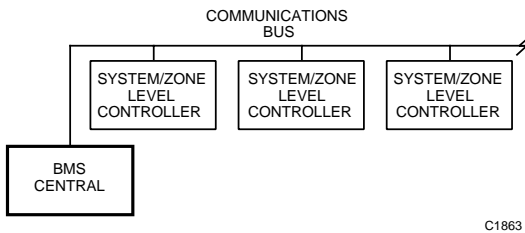

C1863

Fig. 2. Typical Serial Bus Wiring Configuration.

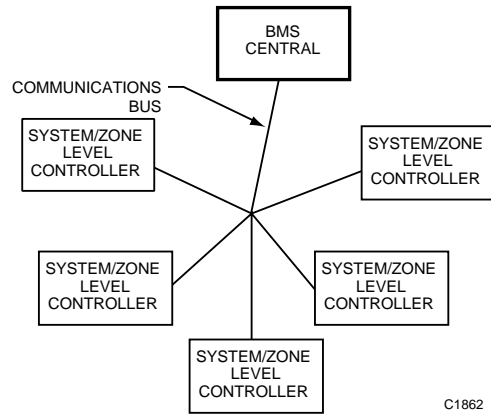

C1862

Fig. 3. Typical Star Wiring Configuration.

FIBER OPTIC

Fiber optic transmission media is particularly suited to installation in an environment that interferes with communications, such as high electrical interference or frequent electrical storms. The disadvantages of fiber optic transmission are the cost and lack of industry standards. Fiber optic links are most often found between buildings.

PHONE LINES

Common carrier telephone channels link distant buildings. Telephone line transmissions require either full time dedicated phone lines or automatic dialing through modems (Fig. 4).

A modem is required for signal compatibility with the phone line. The BMS dial-up phone line interface provides compatibility with transmission rate and protocol of the phone line and reduces the leased line operation to costs associated only with call frequency and connect time. As an example of reduced costs, historical storage of alarm activity can be included in the remote phone line interface so that the data is transmitted during periodic dialup by the central system. Critical alarms can be programmed at the remote to dial the central system immediately.

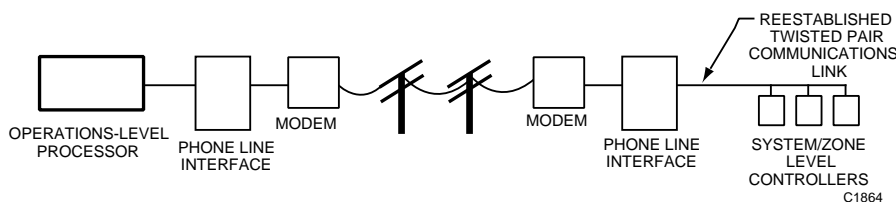

C1864

Fig. 4. Dialup to Remote Controllers.

SYSTEM FUNCTIONS

GENERAL

Each BMCS level provides some degree of stand-alone capability and collects and preprocesses data for other processing levels. The following discussion starts with the functions provided by the lowest level of processing in the configuration, or hierarchy, and progresses to the highest level.

ZONE-LEVEL CONTROLLER FUNCTIONS

The primary function of the zone-level controller is to provide direct digital control of unitary equipment. To support the resident DDC programs, the zone-level controller interfaces with sensors and actuators and performs the functions of point processing as well as execution of the DDC programs.

SYSTEM-LEVEL CONTROLLER FUNCTIONS

System-level controllers provide increased processing capability, higher I/O capacity, and more universal application flexibility than zone-level controllers and have greater stand-alone capability. System-level controllers handle multiple DDC loops and the complex control sequences associated with built-up air handling units and other HVAC equipment. Other types of system-level controllers monitor multiple zones of fire alarm, security points, and/or lighting control. They can also provide emergency evacuation control through speakers and control personnel movement with access control and card readers. For a detailed description of system-level controllers, refer to Microprocessor-Based/DDC Fundamentals section.

Processed point data at the system controller level is used directly by the resident DDC, EMS, and time/event programs. The data is also available for readout at local control panels, portable terminals, and can be communicated up to the operations-level processor and to other system-level controllers. In addition, all parameters and output values associated with DDC and other resident programs are accessible for local and operations-level readout and adjustment. Data point values may be shared between zone-level controllers, between system-level controllers, and between zone- and system-level controllers.

OPERATIONS-LEVEL FUNCTIONS

GENERAL

The operations level is the third tier of the BMCS configuration. Building or facility operations and management personnel interact on a day-to-day basis through this level. The hardware and software for this tier is dedicated

to interfacing with operating personnel rather than with mechanical systems, as the controllers do in the lower tiers of the BMCS configuration.

HARDWARE

The operations-level processor supplies the processing capacity and memory required for all communications and operator interface software as well as the peripheral capacity for dedicated alarm and report printers and work stations. It is usually a PC consisting of:

- Full keyboard, with mouse or other entry device.
- High resolution color monitor.
- RAM or working memory.
- Hard disk memory.
- Diskette drive.
- Multiple peripheral ports.
- Communications interface boards.
- At least one printer.

SOFTWARE

While hardware enables operator interaction and the display and printout of data, the software determines how the interaction takes place, the data is displayed, and the printer output is formatted.

Standard Software

Most BMSs run under Microsoft Windows™ and use standard mouse conventions, such as drop-down menus, dialog boxes, radio buttons, and up-down arrows. Many systems allow the use of other standard Windows compatible programs such as word processors, spread sheets, and data bases to operate concurrently with the BMS. In such cases, a BMS alarm overwrites the monitor screen until acknowledged and canceled.

Other standard programs are often embedded in BMS software. A spread sheet may be an integral part of the trend report utility. This allows the operator not only to view the output of the requested report, but to review and edit it in the spreadsheet format. The spread sheet also can be called up as a stand-alone utility. System graphics are usually based upon standard graphics software.

Communications Software

Software at the operations level communicates with all system- and zone-level processors in a peer-to-peer fashion. Communications functions include:

- Receiving alarm and return-to-normal reports (including remote device communications failures).
- Receiving trend status' and values.
- Passing global data and alarm reports to other devices on the ETHERNET LAN.

- Transmitting requests for display data.
- Transmitting requests for report data.
- Uploading and downloading of controller software.
- Transmitting digital and analog commands.
- Reading/writing controller database points including limits, setpoints, times, and parameters.
- Coordinating global LAN server database including graphic configurations, operator assignments and segregation, history files, and schedule files.
- Entering or editing system-level processor programs.
- Configuring or editing zone-level processor programs.

Server

When using multiple operation/management-level processors, one is defined as the database server, where all current database resides. Any processor may initiate a system change (graphic or text modification, operator assignment, schedule, etc.), but all changes are made to the server database. The server is a software function and may be a dedicated PC or any other LAN processor.

All LAN processors operate from the server, which periodically updates the databases of the other LAN processors. When the server (LAN) is down, the processors operate from their own database.

Security

System security software prevents unauthorized system access and can limit authorized personnel to geographic areas as well as function (acknowledge alarms, issue commands, modify database, etc.). Top level operators assign security passwords and enter security parameters for other operators.

If no keyboard or mouse activity occurs for a predetermined time period, the operator is automatically signed-off. All operator sign-on and sign-off activity is archived.

Alarm Processing

Upon receiving an alarm from a controller, operations-level processors initiate alarm processing as follows:

- Determine if the alarm point is assigned to the receiving processor.
- Rebroadcast the alarm to the server for archival and to other LAN processors.
- If Assigned:
 - Present an immediate alarm message display.
 - Output alarm message to alarm printer.
 - Alarm point text descriptor.
 - Time/Date.
 - Text action message.
 - Present acknowledge button.
 - Initiate audible.
 - No audible.
 - For timed duration or continuously.
 - Fast, medium or slow beep rate.

- (Option) Automation Graphic Display.
- Present button for operator graphic display request.
- Present alarm status on graphics (point red if in alarm, blinking if unacknowledged).

The alarm archive may be queried at any time to analyze historical alarm activity.

Reports

BMS Software includes many system reports for display and printout in addition to alarm reports.

Database reports document system software such as point processing parameters, system text, controller configuration, etc.

The trend report utility allows for archival of data point status and values for subsequent review. Archival may be based upon a time interval or a change in status or value. Trend data may be reviewed as archived or may be sorted and reduced, such as “Print the maximum daily temperature from 3-16-96 to 5-16-96”. Trend data may be presented in columnar format or as a curve plot with up to eight points per display/printout. Trend sample requirements are usually set-up in the controller and automatically reported to the BMS thereafter.

Other standard reports may be:

- All point summary.
- Alarm summary.
- Disabled Points Log.
- Single System Summary (single AHU or single chiller).
- Controller Status Summary.

System Text

BMS system text includes unique names for all controllers, PCs, peripherals, and active communications devices. Each building, HVAC system, and hardware and software point also has a unique name. Each alarm point includes an alarm message (such as “call maintenance”) and may have an extended unique alarm instruction of up to 480 characters. Extended messages typically tell a BMS operator what to do, what not to do, what to investigate, who to call, which forms to fill out, what to order, etc. Unique system text may be in any language which uses ASCII Characters.

System Graphics

A standard graphics package is used to develop system graphics. System graphics start at the total system level including all buildings and systems and are structured in a logical penetration scheme down to the point level. BMS software allows total operator editing including adding new graphics. System points may be used on multiple graphics.

Color is used to differentiate shapes and to define point status. Red may be reserved for alarm, green may be reserved for “Normal On”, and yellow may be reserved for “Normal

Off'. Strong color conventions unclutter graphics by needing less explanatory text, for example; a yellow filter may be clean, a red filter dirty, and a red and blinking filter dirty and unacknowledged.

Buildings, ducts and piping, valves and dampers, floor plans, and most text on graphics are typically static.

Graphics consist of artwork, text, and dynamic points with no positioning restrictions for any element. Dynamic points are typically presented as text in a box; such as 72.9 or Off. The displayed text changes dynamically as the point status or value changes. Displayed status and point values are periodically updated or may be manually updated at anytime. Dynamic points may be presented symbolically as the pumps are in Figure 7. When presented symbolically, dynamic point status and condition are indicated by colors.

Controller Support

A major portion of the BMS Software is the definition and maintenance of system-level controller software. The software allows viewing and editing setpoints and parameters, up or down loading controller databases, adding and editing points and programs, and executing diagnostics.

OPERATION

Operator access to the system is usually positioning the cursor (via a mouse) on a graphic display of a system. Following are examples of BMCS automation concepts for a two building facility with boilers, chillers, and VAV air handlers. When an authorized operator signs on to a system PC, the system recognizes the access authority and presents the top level graphic (Fig. 5)

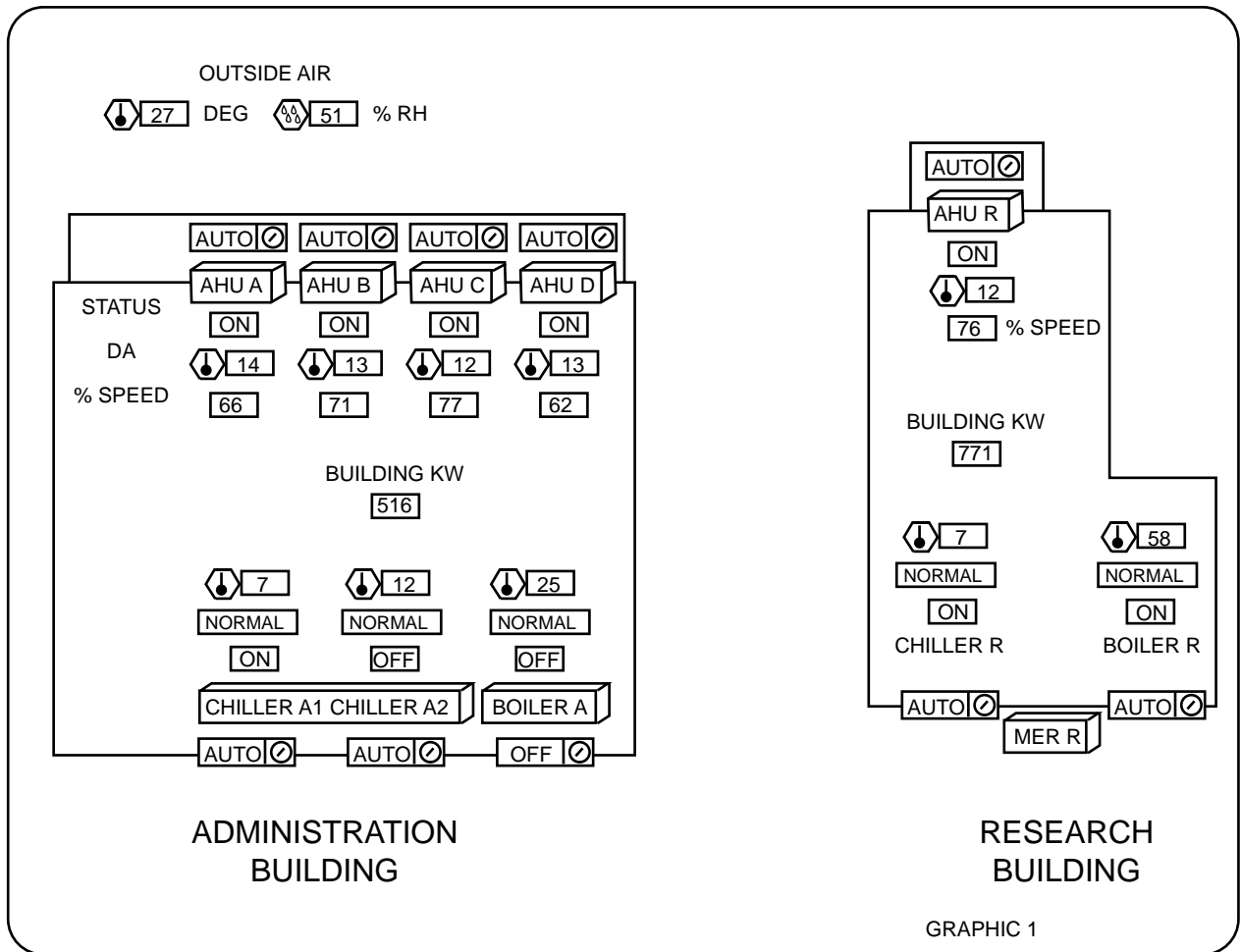

Fig. 5. Top Level Graphic Display of a Two Building Facility.

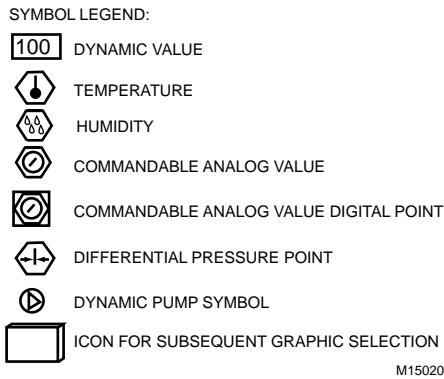

Fig. 6. Graphic Symbols used on Graphic Displays.

Each graphic should contain dynamic system information. Graphic 1 includes 44 points of dynamic system information (rectangular boxes), and eight penetration icons, summarized as follows:

- AHU A-D, AHU R, CHILLER A1 CHILLER A2, MER R, and BOILER A are icons. Selecting an icon displays the appropriate next level graphic.
- 27 and 51 are the current outside air conditions. These values and the other dynamic data points shown are required elsewhere for control and/or automation. Since they are required elsewhere they are in the data base and available to put meaning in this top level facility graphic.
- ON, OFF (10 points) shows the current status of the air handlers, boilers, and chillers.
- NORMAL (5 points) shows the current status of the boiler and chiller controls. These are monitor/automation points not required for control. In an alarm condition, the text changes to ALARM, the point turns to red, and the red blinks until an authorized operator acknowledges the alarm.
- AUTO/OFF (10 points) are commandable. Cursor selection of these points, allows commanding points ON or OFF.
- 7, 12, 25, 58 (5 points) depict the current hot and chilled water discharge temperatures.
- 12, 13, and 14 (5 points) depict the current discharge air temperatures of AHU A-D and AHU R.
- 62, 66, 71, 76, 77 (5 points) depict the current AHU A-D and AHU R VAV fan speed.
- 516 and 771 indicate the instantaneous building kilowatt use.

In Figure 5 the AUTO/OFF points, the hot and chilled water discharge temperatures, and discharge air temperatures typically would be alarm points. They will respond similarly to a NORMAL/ALARM point if they are not as commanded or not within acceptable limits.

Operator selection of the “CHILLER A1 CHILLER A2” icon displays the graphic shown in Figure 7 which has 42 data points and three icons for subsequent penetration, summarized as follows:

- 4 Cooling tower isolation valve position indicators.
- 2 Cooling tower % fan speed indicators.
- 9 Temperature indication points.
- 2 ON-OFF-AUTO command points for each chilled water pump.
- 4 Pump dynamic symbols (On—green, Off—yellow, unacknowledged alarm—red flashing, acknowledged alarm—red).
- 2 Control command status display points to indicate status of control command to each chiller system.
- 2 AUTO-OFF command point for each chiller.
- 2 Chiller status indicators.
- 2 Maximum % load commandable current-limiting points.
- 2 % maximum current indicator for each chiller.
- 2 Alarm status indicator for each chiller.
- 2 Commandable chilled water temperature minimum and maximum setpoints.
- 1 Current chilled water temperature setpoint indicator.
- 2 Pressure control valve % open indicators.
- 3 Pressure control points; current value and commandable setpoint for differential pressure bypass value, and the commandable differential pressure offset value to be subtracted when both chiller pumps are operating.
- 1 Commandable lead chiller selector.
- 1 Icon for a subsequent cooling tower control graphic(s) with setpoints and sequences.
- 1 Icon for a subsequent pressure bypass and choke valve control graphic(s).
- 1 Icon for a subsequent chiller control setpoints and sequences graphic.

Whereas building control strategies are often established independent of who will be “operating” the building, operator graphics should not be. Although the graphic (Fig. 7) presents an adequate overview of the chiller plant for a building engineer, it would be overwhelming for custodial or clerical types. They would not understand the graphic and could cause serious damage if they issued wrong system commands. Graphic data compositions must consider the operators ability to understand and need to know.

Selecting a commandable point presents analog or digital command options to be executed via dialog boxes, radio buttons, up-down arrows, etc. Selecting an analog input allows modification of alarm limit values. Selecting an alarm point allows entry and modification of the alarm message.

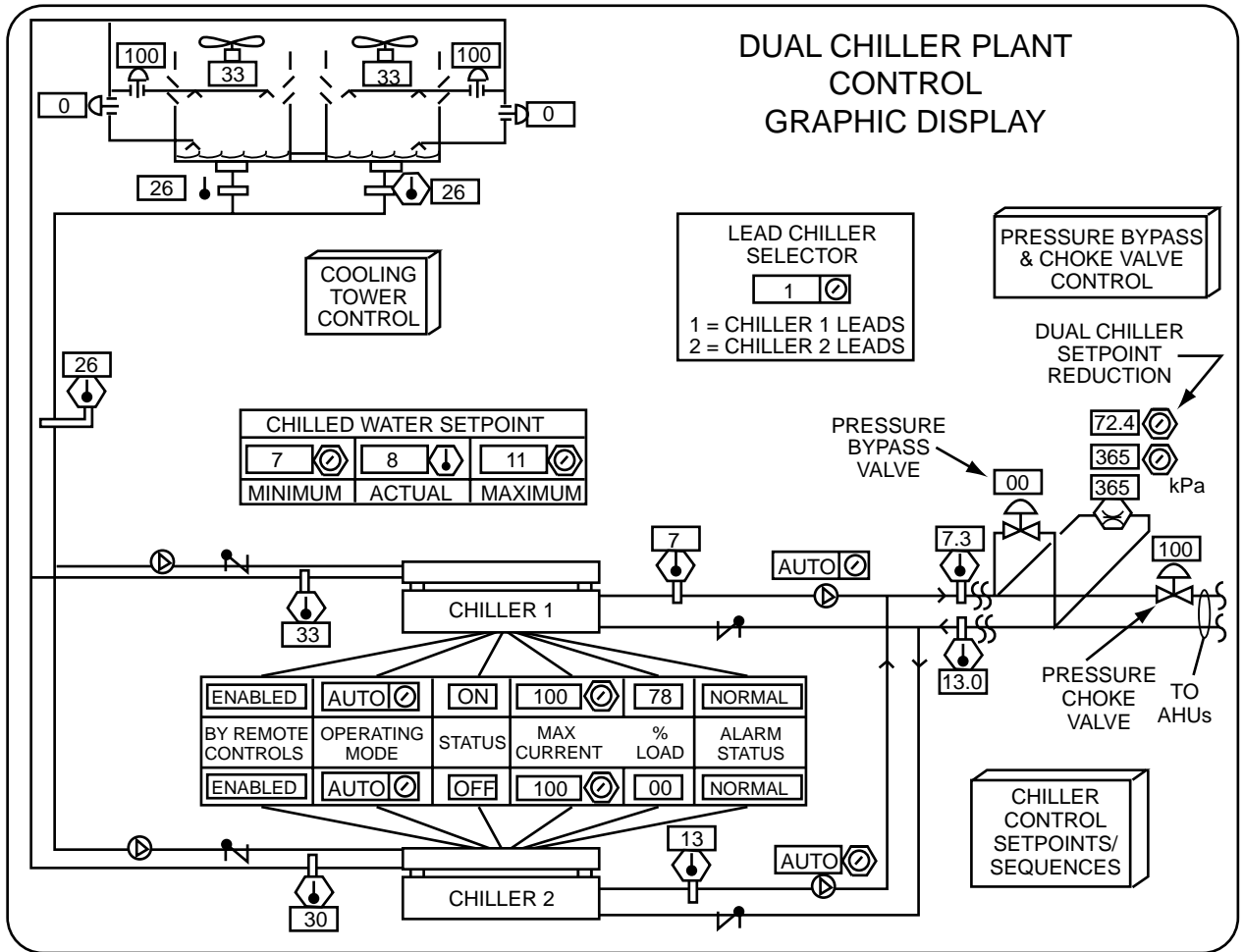

M15136

Fig. 7. Graphic Sketch for Sequence of Operation.

SPECIFYING GRAPHICS (I/O SUMMARIES)

When writing the control sequence of operation, sketch the graphic (Fig. 7) and note the necessary inputs and outputs required for control. Develop an Input/Output (I/O) Summary (Fig. 8) where, the X-axis lists generic types of points and the

Y-axis lists the specific points. Publishing the graphic sketch with all hardware and software points and symbols is an excellent alternative to the I/O summary.

CONTROL GRAPHICS

Many digital control strategies require fine tuning to assure systems are staged and loaded without excessive surging and cycling. Such strategies are often more comprehensive if presented as a “Dynamic Sequence” where the specified sequence is repeated with dynamic commandable values embedded (Fig. 9).

DATA PENETRATION

Figures 7, 8, and 9 present data penetration concepts from the macro to the micro levels. Graphics should be designed for

each specific operator type. For example, a security guard is required to monitor certain critical alarm points after hours, design special graphics of only those points, with simplified explanations, and specific operator response messages. Use simplified floor plan graphics with appropriately positioned dynamic space temperatures for zone controllers. Selection of the VAV icon (controller) presents the specified points (setpoint, min-max airflow, damper position, etc.) on a terminal unit graphic.

All system points should be positioned on graphics and certain points should be specified on multiple graphics.

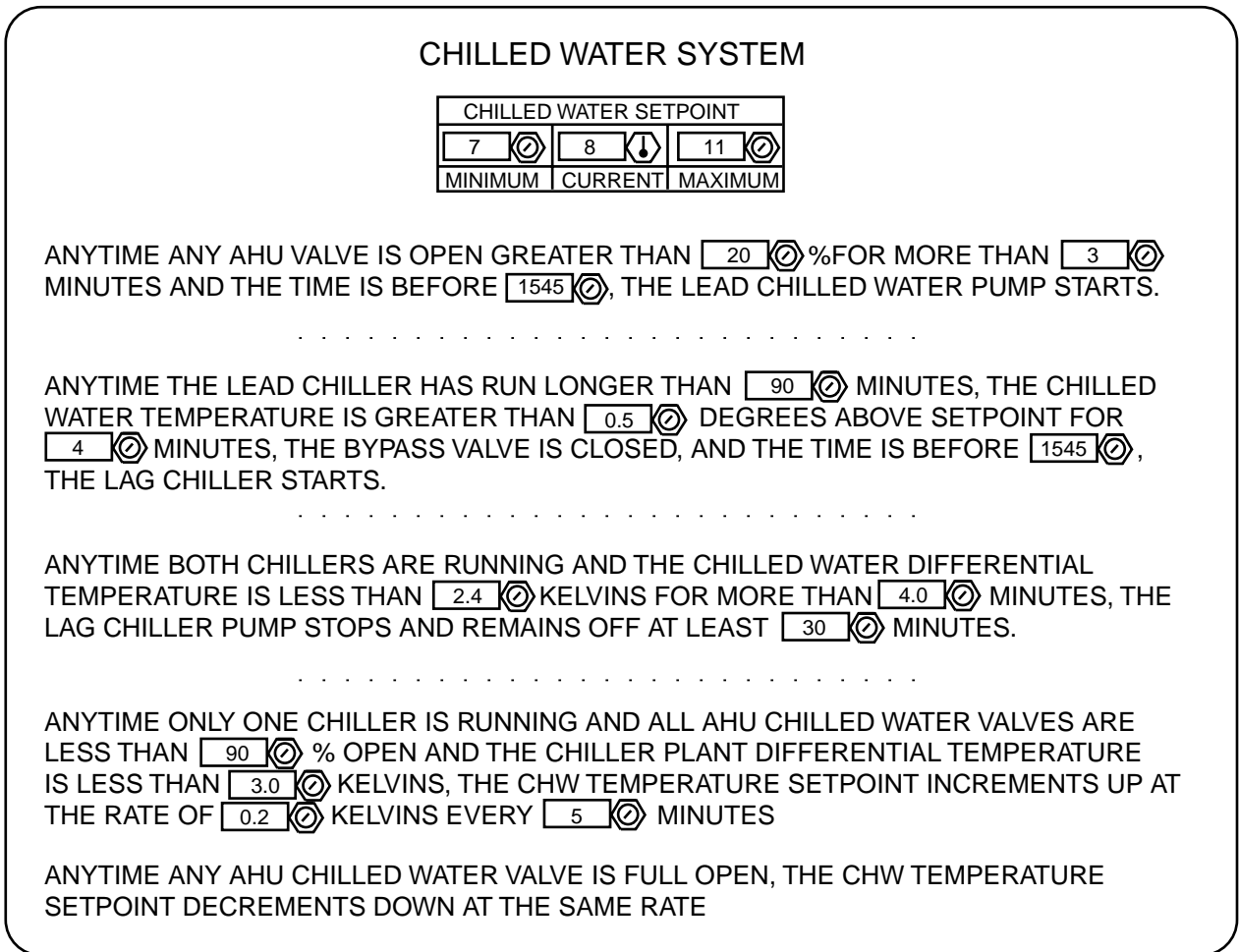

M15135

Fig. 9. Typical Graphic to Aid System Fine Tuning in the Field.

INTEGRATION OF OTHER SYSTEMS

GENERAL

Information from other subsystems, such as fire alarm, security, access control, or lighting control, may be required in the BMS. This can be achieved through system integration. There are two ways to integrate these systems: surface integration and in-depth integration. These subsystems are not described here but are mentioned because of their importance in the BMS architecture.

SURFACE INTEGRATION

A surface integrated subsystem is a stand-alone system which provides certain point information to the BMS. See Figure 10. The subsystem transmits alarm and status information through multiple point connections hardwired to a local BMS panel. The BMS processes and displays that data as auxiliary information or uses it as inputs to resident programs such as time/event sequences. Every input desired in the BMS requires a separately wired point from the subsystem. Since these subsystems are stand-alone systems, they have an operator interface which can be monitored separately from the BMS monitor. There are cases where a second window in the BMS terminal display is dedicated to the operation of the connected subsystem. This usually requires only a standard link to the BMS terminal. In this case, the terminal is shared but no information is passed to the BMS for use in operations. Additionally, the display for the subsystem will generally be entirely different in format from the display for the rest of the BMS. Consequently, this type of integration is of limited use.

The advantage of surface integration is that limited subsystem information is made available to the BMS. This type of integration is generally used to tie in existing systems to eliminate the need to replace functioning equipment.

The disadvantages of surface integration are:

- Higher first cost because of duplicated equipment and increased installation to connect the two systems
- Interconnection between systems is not supervised and could fail without notifying the central
- Independent operations staffs may be required for monitoring each subsystem

IN-DEPTH INTEGRATION

Figure 11 shows a system with in-depth integration. System-level controllers communicate over a common bus for each subsystem. These processors are designed to operate as stand-alone systems if the communication link with the operations-level processor fails. The system-level controllers for fire and security subsystems can also provide outputs for local annunciation if required by applicable codes. All data is accessible through all PC stations, however all operators need not be authorized to access all data. All of the subsystems are tied together through software. Information can also be passed to additional buses containing other subsystems such as lighting control for true global control. This communication is essential for some operations such as smoke control. Even when multiple buses are used, a common display format and centralized collection and dissemination of information throughout the system provides for a more reliable, smoother operating system.

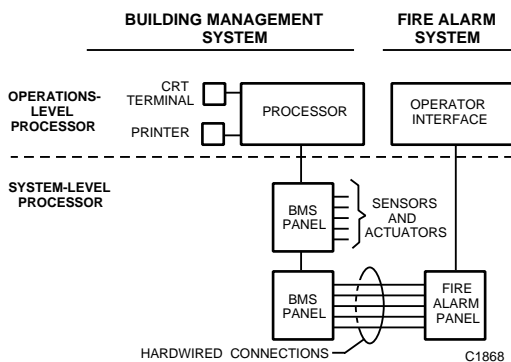

Fig. 10. Surface Integrated System.

Recently, open standard communications protocols have been invented and adopted by the building control and related control industries. These standards, such as BACnet and LonMark™, will make in-depth integration of products and systems from multiple vendors, and from multiple industries, much easier resulting in lower cost and more functional integrations.

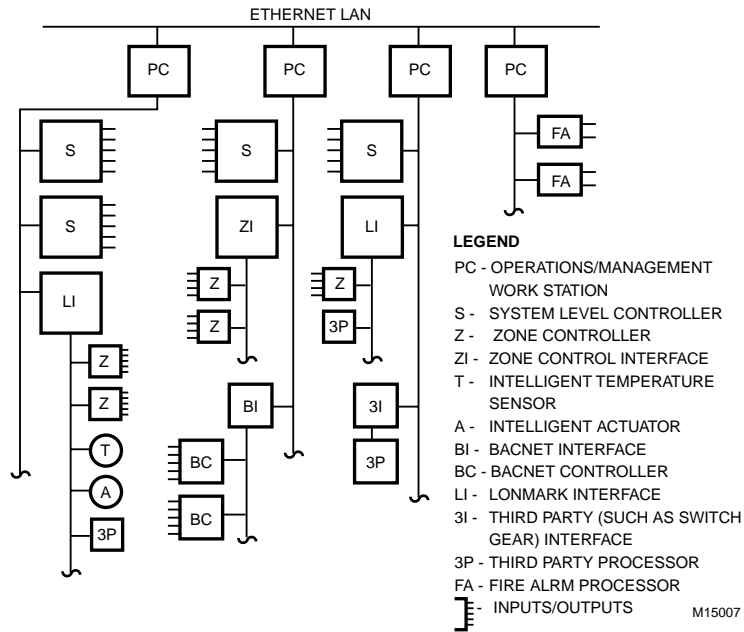

Fig. 11. In-Depth Integrated System.

The advantages of an in-depth integrated system are:

- First costs and ongoing operating costs are usually lower
- Interdependence between subsystems, such as smoke control, can be easily accommodated since there is only one processor
- Independent operating centers at remote locations can be provided

- Third party LonMark™ and BACnet points may be positioned on or added to standard system graphics.

The disadvantage of this type of integration is that care must be taken in configuring the system to be sure that transmission speeds are adequate for all parts of the system.

CONTROL SYSTEM APPLICATIONS

Air Handling System Control Applications

ENGINEERING MANUAL OF AUTOMATIC CONTROL

		CONTENTS
Introduction	203
Abbreviations	203
Requirements for Effective Control	204
Applications-General	206
Valve and Damper Selection	207
Symbols	208
Ventilation Control Processes	209
Fan System Start-Stop Control	209
Fixed Quantity of Outdoor Air Control	211
Outdoor Air Fan Control for Multiple AHU's	212
Mixed Air Control	213
Economizer Cycle Decision	215
Economizer Cycle Decision—Outdoor Air Dry Bulb Control	215
Economizer Cycle Decision—Outdoor Air Enthalpy Control	216
Economizer Cycle Decision—Outdoor Air/Return Air	218
Enthalpy Comparison	218
Economizer Cycle Decision—Outdoor Air/Return Air Dry Bulb	219
Temperature Comparison	219
Mixed Air Control with Economizer Cycle (Ventilation System Only)	..	220
Economizer Cycle Control of Space Temperature with Supply Air	221
Temperature Setpoint Reset	221
Heating Control Processes	223
Control From Supply Air	223
Control From Space with Supply Temperature Reset	224
Outdoor Air Temperature Reset of Supply Air Temperature	225
Space Temperature Control of Zone Mixing Dampers	226
and Reset of Hot Deck Temperature	226
Preheat Control Processes	228
Preheat Control with Face and Bypass Dampers	228
Control from Preheat Leaving Air	230
Multiple Coil Control from Outdoor and Supply Air	231
Year-Round Heat Recovery Preheat System Control	233
Humidification Control Process	235
Control of Modulating Humidifier	235

Cooling Control Processes	236
Control of Modulating Chilled Water Coil Three-Way Valve	236
Two-Position Control of Direct Expansion Coil System	238
Two-Position Control of Direct Expansion Coil System— Modulating Face and Bypass Damper	239
Cold Deck System with Zone Damper Control	241
Dehumidification Control Processes	243
Direct Expansion or Water Coil System Control	243
Water Coil Face and Bypass System Control	244
Heating System Control Process	246
Space Control of Heating, Economizer (Free Cooling), and Humidification	246
Year-Round System Control Processes	248
Heating, Cooling, and Economizer	248
Multizone Unit	250
Heating, Cooling, Humidification, and Dehumidification Control without Dead-Bands	252
VAV AHU, Water-Side Economizer, OA Airflow Control	255
VAV AHU with Return Fan and Flow Tracking Control	258
ASHRAE Psychrometric Charts	261

INTRODUCTION

This section describes control applications for air handling systems commonly found in commercial buildings. The basic processes such as heating, cooling, humidification, dehumidification, and ventilation are presented individually then combined into typical air handling systems. A discussion covering requirements for effective control is also included to provide guidelines for the design of the actual air handling systems with the related controls. Examples are based upon digital control systems. These digital control strategies may not be practical with other forms of control, and may not be possible with all digital controllers or by all digital controller programmers.

Also throughout the section, dashed lines indicate interlocked links and solid lines functional relationships between control items.

Psychrometric aspects are included for most applications. They are shown in abbreviated form. Unabridged copies of ASHRAE Psychrometric Charts No. 1 and No. 2 are included at the end of this section for reference. For further understanding of the basics of psychrometric charts refer to the Psychrometric Chart Fundamentals section.

For additional detailed information on air handling systems, refer to the ASHRAE 1996 HVAC Systems and Equipment Handbook.

ABBREVIATIONS

The following abbreviations are used throughout this section in the text and drawings. Refer to Definitions in the Control Fundamentals section and the Psychrometric Chart Fundamentals section for further details.

AHU — Air Handling Unit
BCMS — Building Control Management System
C — Celsius
DB — Dry Bulb
DDC — Direct Digital Control
DP — Dew Point
EA — Exhaust Air
EPID — Enhanced PID
IAQ — Indoor Air Quality
L/s — Liters per second

MA — Mixed Air
MAT — Mixed Air Temperature
N.C.¹ — Normally Closed
N.O.² — Normally Open
OA — Outdoor Air
OAT — Outdoor Air Temperature
P — Proportional
PI — Proportional-Integral
PID — Proportional-Integral-Derivative
RA — Return Air
RAT — Return Air Temperature
RH — Relative Humidity
SA — Supply Air
VAV — Variable Air Volume
WB — Wet Bulb

¹ Applies to valves and dampers that are actuated to fail in the closed position in the event of loss of motive force.

² Applies to valves and dampers that are actuated to fail in the open position in the event of loss of motive force.

REQUIREMENTS FOR EFFECTIVE CONTROL

Effective control system performance requires careful design of the mechanical system and selection of components. Consideration needs to be given to the following by the mechanical system designer and the control engineer:

1. **PROPERLY DESIGN DISTRIBUTION SYSTEM TO DELIVER AIR TO THE SPACE.**
 - a. Extend ductwork to all parts of the space.
 - b. Insulate ductwork if it runs through a space where the temperature is considerably different from that of the air within the duct or if the space dew point is likely to be above the supply air temperature.
 - c. Locate outlets only where the air in the duct is well mixed.
 - d. Locate RA grilles where they will aid in distribution and eliminate short circuiting of the supply air.
2. **PROPERLY SELECT DIFFUSERS AT OUTLETS TO THE SPACE.**
 - a. Do not have low ceiling diffusers blow directly downward.
 - b. Use several small diffusers rather than one large one.
3. **PROPERLY SIZE AND SELECT HEATING COILS.**
 - a. Size coils to meet their maximum loads. Avoid oversized coils for best control.
 - b. Use multiple inline coils where the required temperature rise is high.
 - c. Select coils for even distribution of the heating medium at light loads to prevent surface temperature gradients and accompanying stratification.
 - d. Furnish preheat coils with a maximum temperature rise of 16 to 19 Kelvins.
 - e. Provide multiple low-temperature controls to protect large coils. Provide one for every two square meters of coil face area with the element location favoring where cold air is more likely to be.
4. **PROPERLY SIZE AND SELECT COOLING AND REFRIGERATION EQUIPMENT.**
 - a. Consider dividing the cooling capacity among several coils.
 - b. Consider some form of reheat if dehumidification is required.
 - c. Prevent short cycling of compressors under light load by:
 - 1) Installing multiple compressors where large capacity sequencing is needed.
 - 2) Providing means of loading and unloading a compressor under light load.
 - 3) Sizing the refrigeration equipment accurately.
 - 4) Providing minimum on and off time delays.
 - 5) Providing a hot gas bypass.
5. **CONSIDER SEPARATE MECHANICAL SYSTEMS FOR AREAS IF THEIR HEATING OR COOLING LOADS DIFFER GREATLY FROM THE OTHER AREAS.**
6. **ELIMINATE STRATIFICATION IN THE DUCTS.**
 - a. Use mixing chambers or other mechanical devices where mixing is critical.
 - b. Use the system fan to mix the air. A single inlet fan mixes air more effectively than a double inlet fan.
 - c. Arrange steam coils so that the supply header is on the longest dimension if possible.

NOTE: No one of these methods provides a complete answer to the stratification problem. They should be used in combination where needed.
7. **PROVIDE PHYSICAL ARRANGEMENT OF SYSTEM COMPONENTS TO PERMIT SUITABLE LOCATION OF SENSING ELEMENTS.**
 - a. Furnish sufficient spacing between coils to permit installation of sensing elements.
 - b. Provide ductwork downstream from a coil or other components to allow placement of the sensing element in an unstratified mixture of exiting air.
8. **PROPERLY LOCATE THE SENSING ELEMENT.**
 - a. Locate sensing elements where they will measure the variables they are intended to control.
 - b. Locate space sensing elements on an interior wall where they can measure a condition representative of the whole space.

NOTE: Space sensing elements can sometimes be located in the RA duct as close to the space as possible if another suitable location cannot be found.

 - c. Locate duct sensing elements in an unstratified air mixture.
 - d. Locate air pressure and flow pick-up elements away from immediate fan discharges and provide with capacity tanks where necessary to eliminate surges and pulsations.
 - e. Locate humidifier leaving air humidity sensors no less than 2.5 and no more than 9 meters downstream of the humidifier.

9. CONSIDER THE PHYSICAL ARRANGEMENT OF HUMIDITY SYSTEM COMPONENTS.

- a. Locate humidifiers downstream from a source of heat.
- b. Locate reheat coils downstream from cooling coils.
- c. Provide unlined ductwork downstream of humidifiers, and straight for a minimum of three meters.

10. PROPERLY SIZE AND SELECT THE CONTROL VALVES.

- a. Do not oversize modulating control valves. Refer to the Valve Selection and Sizing section.
- b. Select control valves that position properly upon HVAC shutdown and upon loss of motive force. (Refer to Table 1.)

11. PROVIDE THE AIR HANDLING SYSTEM WITH LOW TEMPERATURE PROTECTION WHERE FREEZING TEMPERATURES ARE POSSIBLE.

- a. For steam coils, give consideration to:
 - 1) Providing vertical tubes.
 - 2) Pitching coils properly to the trap.
 - 3) Providing vacuum breakers.
 - 4) Providing traps of proper type, size, and location.
 - 5) Providing adequate drip and cooling legs.
 - 6) Locating steam valve at high point.
 - 7) Providing face and bypass type coils.
- b. For hot and chilled water coils, give consideration to:
 - 1) Providing coil pumps to assure flow through coils during periods of subfreezing temperature.
 - 2) Using antifreeze solutions.
 - 3) Operating all water pumps when OA is below 1.5°C.
 - 4) Draining idle coils and lines.
- c. For control applications, give consideration to:
 - 1) Providing low temperature limit controllers for all systems to enable one or a combination of the following:

NOTE: Ensure that temperature sensing elements are exposed to coldest portion of airstream.

- a) Opening valves to provide full flow to coils.
- b) Starting pumps.
- c) Closing OA dampers.
- d) Starting fan to circulate RA.
- e) Stopping fan if 100 percent OA system.
- f) Initiating low temperature alarms.
- g) Stopping fan if steam is not present.

- 2) Providing failure alarms for pump, coils, and other heating systems components.

12. ALLOW AIR HANDLING AND CONTROL SYSTEM DESIGN TO PROVIDE ENERGY CONSERVATION.

- a. Use space sensors, rather than OA sensors, to determine reset schedules. For example, use the damper signal from space PI control loops to reset multizone unit hot and cold deck temperature controller setpoints.
- b. Do not permit air handlers to introduce OA to a building area which is unoccupied or during the warm-up period unless required for night purge or IAQ.
- c. Use PI control where elimination of control offset conserves energy or increases comfort.

13. PROVIDE HVAC VENTILATION SEQUENCES THAT COMPLY WITH CURRENT IAQ CODES AND STANDARDS.

14. NETWORK DIGITAL CONTROLS FOR BUILDING-WIDE ENERGY AND COST PERFORMANCE.

- a. Share points such as OA temperature among controllers.
- b. Have chiller strategies address fan system demands.
- c. Have pumping system strategies address control valve demands.
- d. Have fan system strategies address space terminal unit demands.

15. SEE THAT CONTROL SYSTEM DESIGNERS FULLY UNDERSTAND THE COMPLETE BUILDING HVAC SYSTEM.

Refer to HVAC system components manufacturers recommendations for application requirements and guidelines.

16. HARD-WIRE SAFETIES IF HAND-OFF-AUTO SWITCHES ARE PROVIDED

- a. Hard-wire all temperature low limit, fire, and pressure safeties if the system can be easily operated manually. In cases where a PC operator monitoring station is provided, the safeties are also usually monitored by the local digital controller.
- b. If override switches are not provided, and system operation is always dependent upon the digital control system, safeties may be wired to the digital controller for control and monitoring, thus saving duplicate wiring.
- c. The real value of the safeties is achieved by proper mounting, testing, and maintenance of such devices.

17. PLACE CONTROL VALVES ON THE LEAVING SIDE OF WATER COILS.

Control valves on the leaving side of water coils leaves pressure in the coil when the valve is closed, thus aiding in eliminating air through the air vent on the leaving side of the coil, and also prevents the possibility of air being induced into the system through the vent if the pump produces a negative pressure in the coil return line.

18. CONSIDER THE ABILITY OF THE HVAC SYSTEM OPERATOR TO UNDERSTAND THE SYSTEM WHEN DESIGNING GRAPHICS FOR THE OPERATOR INTERFACE.

APPLICATIONS-GENERAL

The following applications are presented in a DDC format using notation from the Symbols in this section. In some cases the degree and complexity of control shown is not practical in other forms of control.

Suggested microprocessor data points are shown as they could appear on a color graphic display of a PC operator workstation. In some cases data points, other than those required for control and operation, are shown to help an operator understand the loading and performance of the HVAC system and related control loops. If a PC station is not required, the data points required for control and operation should still be specified for the operator by listing the points or including a graphic sketch.

Values, setpoints, gains, timings, etc. shown in these examples are general, and actual values should be determined on a project-to-project basis.

The following applications were selected for this section on Air Handling System Control Applications. Caution should be used in simply combining any of these applications together as a control solution for a more complex system. Application variations may be required depending on the heating, cooling, and pumping configurations, the building use and occupants, the ability of control vendors and related control systems, the ability of local operating and maintenance persons, codes, and weather.

Lines connecting inputs, outputs, values, and control functions have been added to aid in understanding. In many cases these lines would create unacceptable clutter on an actual system graphic display. Graphic display and management function (alarms, records, etc.) concepts are discussed further in the Building Management System Fundamentals section.

Although the control solutions presented are good general recommendations, other solutions are acceptable, and in some cases, may better depending on the job objectives.

VALVE AND DAMPER SELECTION

Pneumatic valve and damper actuators are shown in these examples. If actuators are electric, certain ones need not be spring return unless a specific reason exists. Table 1 outlines general

actuator selection. The table indicates actuator positioning desired on system shutdown and loss of motive force.

Table 1. Valve and Damper Actuator Selection Guide.

Actuator Application	Pneumatic Actuators		Electric Actuators	
	System Shutdown	Loss of Air	System Shutdown	Loss of Electricity
Dampers				
Outdoor air	Closes	Closes	Closes	Closes
Relief air (to outdoor)				
Return air	Opens	Opens	Opens	Opens ¹
VAV fan inlet vanes	Closes	Closes	Closes	Closes
VAV box	Owner Preference	Opens	Owner Preference	Owner Preference
Multizone hot deck, cold areas	Opens		Opens	Opens
Multizone hot deck, hot areas	Closes	Closes	Closes	Closes
Valves				
AHU chilled water	Closes	Opens	Closes	Stays same
Terminal reheat			Opens ²	
Preheat in OA below 1.53C	Closes		Closes	
Preheat in OA above 1.53C	Closes ²		Closes ²	Stays same
AHU steam heating	Closes	Closes	Closes	Closes
Steam humidifier				

- ¹ Return air dampers need no springs if the associated fan is delayed upon start-up to allow the RA damper to properly position to assure that the fan does not start with both RA and OA dampers closed.
- ² If a duct temperature sensor is located near a hot water or steam coil, leaving the coil under control (with a setpoint of 273C to 383C) during equipment shutdown can provide added freeze alarm protection. If variable flow hot water pumping is provided and a duct low temperature control senses freezing conditions, hot water valves may be positioned approximately 25% open if a temperature sensor is not available.

SYMBOLS

The following symbols are used in the system schematics following. These symbols denote the nature of the device, such as a thermometer for temperature sensing.

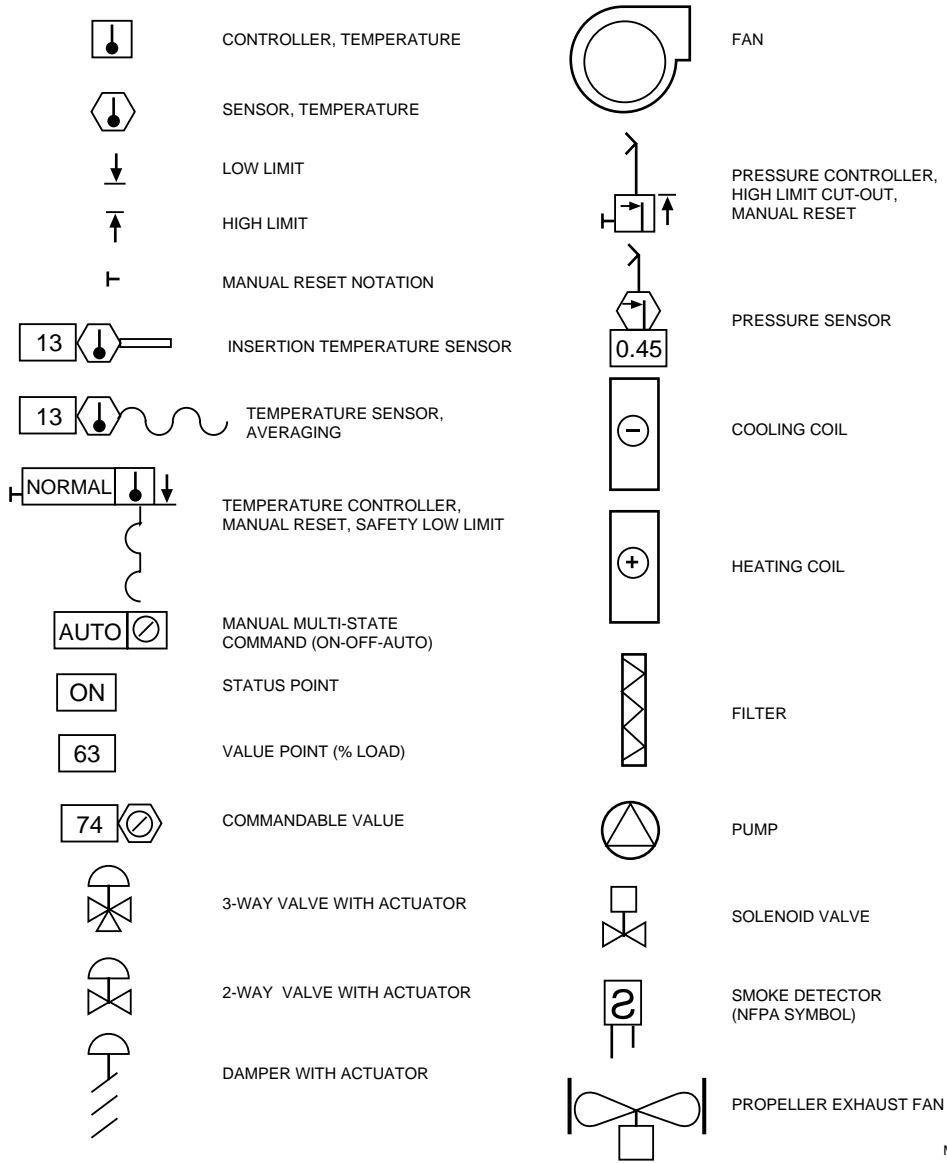

M15150

VENTILATION CONTROL PROCESSES

The following applications show various ways of controlling ventilation in an air conditioning system.

FAN SYSTEM START-STOP CONTROL

FUNCTIONAL DESCRIPTION

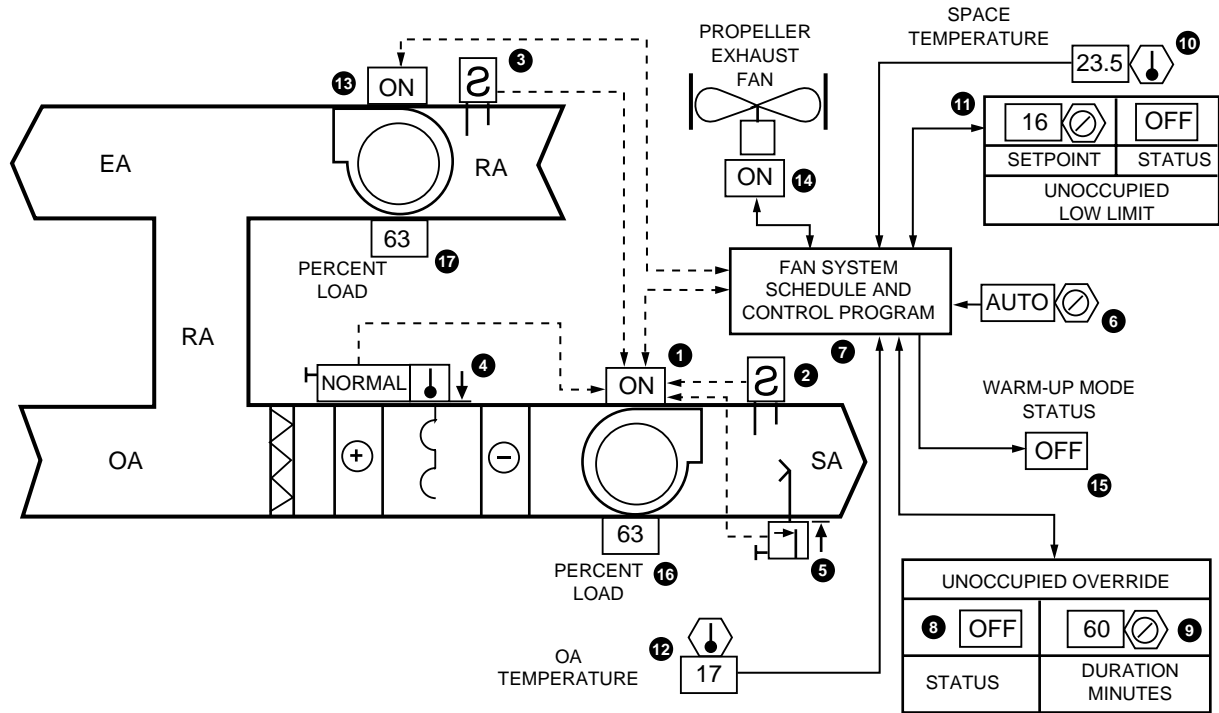

M15151

Item No.	Function
1	Supply fan starts and enables return fan start and system controls.
2	SA smoke detector stops supply fan when smoke detected.
3	RA smoke detector stops supply fan when smoke detected.
4	Controller stops fan when low temperature detected.
5	SA high static pressure control stops fan when unsafe pressure exists.
6	Automatic fan system control subject to commandable ON-OFF-AUTO software point.
7	Control program turns supply, return, and exhaust fan on and off dependent upon optimized time schedule, unoccupied space temperatures, and occupant override requests.
8	Occupant override switch provides after hours operation when pressed.
9	Duration of operation for override request.
10	Space temperature (perimeter zone) inputs to optimum start-stop, unoccupied purge, and low limit programs.
11	Setpoint at which unoccupied low-limit program executes.
12	OA temperature input to optimum start-stop program.
13	Return fan operation enables exhaust fan control program.
14	Exhaust fan status (operator information).
15	Warm-up mode status (operator information).
16	Supply fan load (VAV type systems-operator information).
17	Return fan load (VAV type systems-operator information).

FEATURES

1. Smoke, low temperature, and high static pressure safety shutdown (hardwired).
2. Optimized start-stop control of supply, return, and exhaust fans.
3. Proof of operation interlocking and alarming on supply and return fans.
4. Software on-off-auto system command.
5. Zero ventilation/exhaust during preoccupancy operational periods.
6. May be modified for night purge and prepurge operation.
7. After-hours operation function; duration is operator adjustable.
8. Positions valves and dampers properly during off modes.
9. Night low temperature operation.
10. See Smoke Management Fundamentals section for smoke control considerations.

CONDITIONS FOR SUCCESSFUL OPERATION

1. See REQUIREMENTS FOR EFFECTIVE CONTROL.
2. Proper hardware and software interlocks with heating, cooling and terminal equipment.
3. To protect the AHU housing and ductwork, the high pressure cutout must be hardwired and located with a minimum of tubing to prevent delays of operation. Modulating limit control is not recommended since the problem causing the high pressure is rarely a control loop malfunction, but a physical one (smoke damper slamming shut, sensor tubing cut or failed, vane actuator linkage failure, etc.).

LIMITATIONS

1. Heating and cooling equipment must be available to operate.
2. On large 100% OA systems and systems where OA and RA dampers both close upon fan shutdown, dampers should be enabled prior to fan start, and the fan should start only after damper end switches prove dampers are in safe positions.

SPECIFICATIONS

Air handling system shall be under program control, subject to SA and RA smoke detectors, SA high pressure cutout, and heating coil leaving air low-temperature limit control; and shall be subject to system software on-off-auto function.

Supply fan shall be started and stopped by an optimum start-stop seven day time schedule program, an unoccupied low space temperature limit program, or by an occupant via push button request. The push button shall be integral with the space temperature sensor. Any push button request shall provide sixty minutes (operator adjustable) of full system operation.

Return fan shall operate anytime the supply fan proves flow (via a current sensing relay).

The exhaust fan shall operate during scheduled occupancy periods and during occupant requested after-hour periods anytime the return fan proves flow.

Heating/cooling plant (based upon fan system demands), temperature, humidity, pressure, and ventilation controls shall be enabled to operate anytime the fan system operates. Unless otherwise specified, during fan off periods, N.O. heating and cooling valves shall position closed, N.C. steam valves shall position closed, N.C. humidifier valves shall position closed, N.C. outdoor and relief dampers shall position closed, and N.O. RA dampers shall position open.

FIXED QUANTITY OF OUTDOOR AIR CONTROL

Functional Description

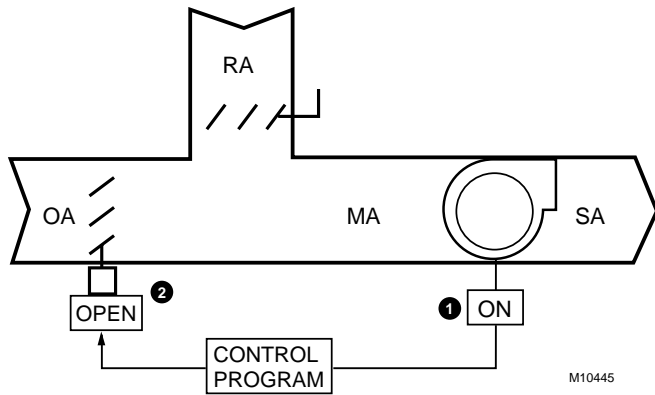

Item No.	Function
1	Control system energizes when fan is turned on.
2	Damper opens on fan startup, closes on fan shutdown.

FEATURES

1. A fixed quantity of OA is admitted when the fan is operating.
2. This system is composed of a minimum of ventilation and control equipment.

CONDITIONS FOR SUCCESSFUL OPERATION

1. The system provides the desired proportions of OA and RA (a manual RA damper, shown, is usually required).
2. The system is designed so that coils are not subject to freezing.

LIMITATIONS

The MA temperature varies as a function of OA temperature. The equation is:

$$MAT = \frac{OA (m^3/s)}{Total (m^3/s)} (OAT - RAT)$$

or:

$$MAT = (RAT \times \%RA) + (OAT \times \%OA)$$

Example, calculate the mixed air temperature of a 4.720 m³/s fan with 25% OA at -15°C. RA is 24°C.

$$MAT = 24 + \frac{1.180}{4.720} [(-15) - 24] = 14.25^\circ C$$

or:

$$MAT = (24 \times 0.75) + (-15 \times 0.25) = 14.25^\circ C$$

SPECIFICATIONS

The operation of the OA damper shall be two-position. The OA damper shall open when the fan is on and close when the fan is off.

PSYCHROMETRIC ASPECTS

The proportions of OA and RA admitted are constant at all OA temperatures.

In the following chart it is assumed that:

1. One-third OA and two-thirds RA are admitted.
2. RA condition is 26°C DB and 17°C WB.
3. OA condition is 4°C DB and 1.5°C WB.
4. MA = (2/3 x 26) + (1/3 x 4) = 18.3°C.

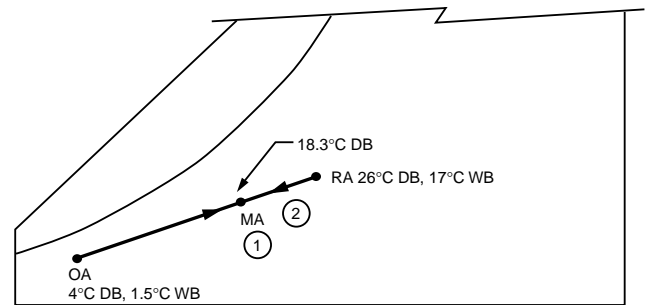

C3235

The following results are obtained:

Item No.	Explanation
1	MA condition at 4°C DB OA condition.
2	As OA temperature rises, the MA temperature moves to the right of the initial MA temperature.

OUTDOOR AIR FAN CONTROL FOR MULTIPLE AHU'S

Functional Description

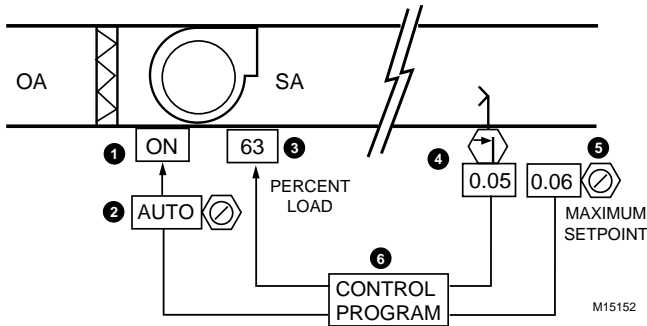

Item No.	Function
1,2	Fan runs under building system control, subject to software on-off-auto function.
3-5	Fan loads to maintain duct static pressure setpoint. Static pressure setpoint varied by AHU OA damper positions to maintain minimum pressure to satisfy all operating AHU fan OA damper positions.
6	Control program coordinates fan start-stop and loading.

FEATURES

1. OA fan provides minimum OA for multiple AHUs, which are usually stacked one above the other in a tall building. Each AHU has a minimum airflow OA damper and airflow station.
2. Duct pressure (and fan loading) optimized to satisfy AHU with greatest demand.
3. Pressure increased during night purge and ventilation prepurge modes to accelerate cycles.
4. OA filter reduces AHU filter burden, reduces OA fan maintenance, reduces air flow station maintenance, and prevents OA airflow from dropping as filter loads.

CONDITIONS FOR SUCCESSFUL OPERATION

1. Control network, software, and programming advises OA fan of AHU damper demands.
2. The system is designed so that coils are not subject to freezing conditions.

SPECIFICATIONS

The OA fan shall start anytime any AHU operates in the occupied, night purge, or prepurge mode, subject to a software on-off-auto function.

The OA fan loading shall be under EPID (see Control Fundamentals section) control with a start value of 25% and a ramp duration of 250 seconds.

NOTE: EPID was selected (and designed specifically) for this type of application because of the start-up nature of VAV fans. The problem is the large PID error signal (the difference between the actual duct pressure and duct pressure setpoint) that exists at the start moment. At startup the duct pressure is zero and the setpoint of the VAV supply fans is usually over 250 pascals, at which point the proportional element of PID calls for heavy loading, and the integral element adds to that. Over half the time the real fan startup load is minimal since the building is not warm and the VAV boxes start at or near their minimum airflow setpoint. It is therefore very predictable that the fan will accelerate rapidly, the duct pressure will rise rapidly (and, with PID, will overshoot), and unsafe conditions may occur.

Recognizing this, EPID starts the fan at a minimum loading, senses the error, and ramps the error slowly and linearly into PID control usually over a 30 to 90 second period (adjustable to any value). Thus the fan loads quickly to 20 or 25%, then loads slowly thereafter. As the error is fed into PID, the fan loads to remove the error (and does remove it as it is received), and the setpoint is reached in a very orderly and controlled manner with no overshoot. During startup, EPID control runs the motor at a speed high enough to prevent overheating and to reach a load level to prove operation to any monitoring BMCS; however, the speed is lower than that necessary to meet the VAV boxes minimum airflow demand.

With pneumatic proportional control, branch line restrictors are often placed in the air line to the inlet vane actuator (or to the variable fan drive transducer line) to slow this loading (a check valve can be installed around the restrictor such that unloading is instantaneous). PI control, can have "integral windup", which accumulates during times that a P error is allowed to exist. The integral windup raises the P setpoint so the fan starts with full capacity and can overpressure the supply ducts. The restricted branch line allows the branch signal to increase slowly.

Anytime all AHUs operating in the occupied mode have OA dampers less than 80% open, the OA fan duct static pressure setpoint shall be decremented at the rate of 25.0 pascals every 60 seconds. Anytime any AHU is operating in the occupied mode and the OA damper is full open, the OA fan duct static pressure setpoint shall be incremented at the rate of 25.0 pascals every 60 seconds up to a maximum value. The decrementing and incrementing values shall be verified during commissioning. Anytime any AHU operates in the night purge or prepurge modes, the OA fan duct static pressure setpoint shall be increased to a value equal to 1.5 times the maximum setpoint.

MIXED AIR CONTROL

Functional Description

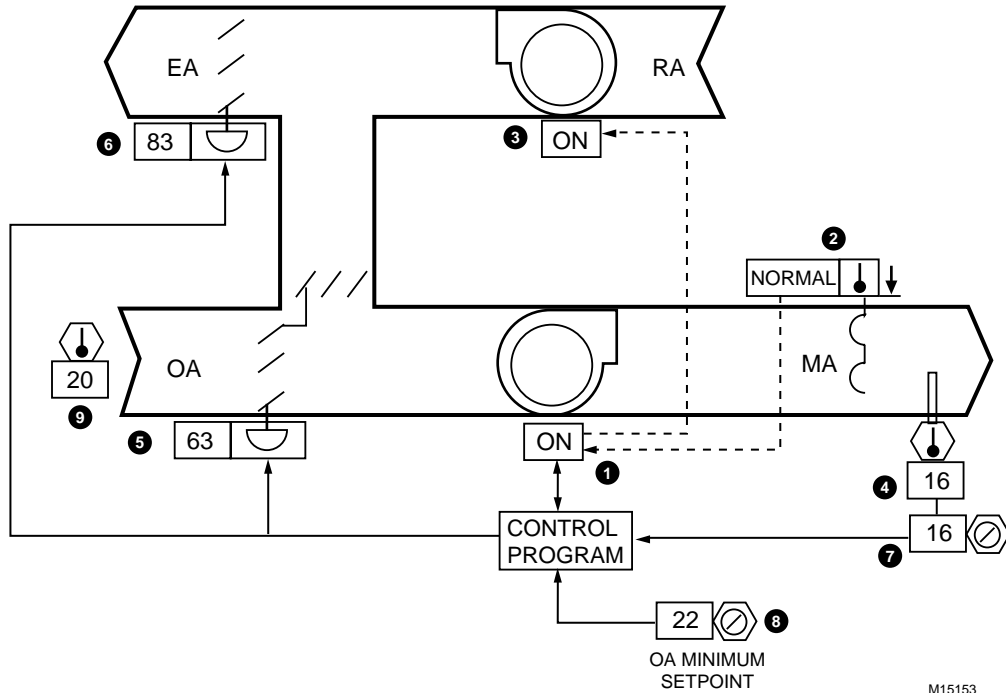

Item No.	Function
1-3	Control system energizes when fan is turned on (See FAN SYSTEM START-STOP CONTROL).
4	MA temperature maintained by modulating mixing dampers.
5,6	OA and EA dampers close and RA damper opens when fan is off, and modulate for temperature control when fan is on.
7	Setpoint for MA temperature control.
8	Damper control and setpoint for minimum ventilation damper position.
NOTE: This is not 22% OA or OA damper open 22%, it is the control program output value necessary to position the OA damper such that the design OA airflow is maintained.	
9	OA temperature, operator information.

FEATURES

1. The proper proportions of OA and RA, above minimum OA setting, are admitted to prevent the MA temperature from dropping below the desired MA temperature.
2. A minimum quantity of OA, determined by the setting of the minimum position signal is assured at all times.

CONDITIONS FOR SUCCESSFUL OPERATION

1. Adequate mixing of OA and RA, which may be obtained using a special mixing chamber.
2. The temperature sensor is located where the air is thoroughly mixed. The discharge of the fan in a blow-through system usually provides adequate mixing.

LIMITATIONS

1. If the manual positioning value is set to admit a large quantity of OA, and the OA temperature falls below the temperature at which MA temperature controls require only minimum OA, a source of heat may be necessary to maintain the MA temperature.
2. During periods of high OA temperature, 100% OA may be undesirable.

SPECIFICATIONS

See FAN SYSTEM START-STOP CONTROL.

Anytime the supply fan runs, the OA, EA, and RA dampers shall be modulated by an MA PID control loop to satisfy the MA temperature setpoint down to a minimum ventilation position.

PSYCHROMETRIC ASPECTS

In the following chart it is assumed that:

1. The manual positioning value is set for one-third minimum OA.
2. RA condition is 24°C DB and 15°C WB.
3. OA condition is 4°C DB and 1.5°C WB.
4. The MA controller is set at 16°C.
5. The desired MA temperature can be maintained until the OA temperature falls below the temperature at which only minimum OA is admitted and until the OA is greater than 16°C.

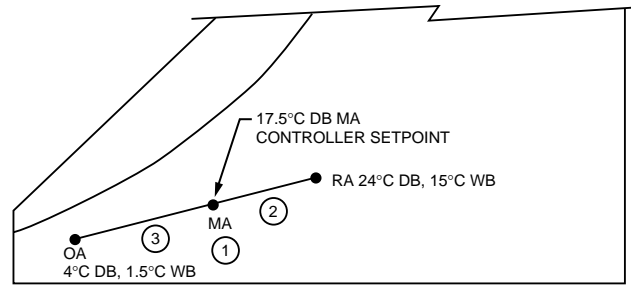

C3236

The following results are obtained:

Item No.	Explanation
1	As OA temperature varies between -1.5°C and 16°C , the MA condition lies on the 16°C DB line.
2	As OA temperature rises above 16°C DB, 100 percent OA is admitted, and the MA condition will lie to the right of the 16°C DB line.
3	As OA temperatures fall below -1.5°C DB, one-third OA (set by the manual positioning switch) is admitted, and the MA condition will lie to the left of the 16°C DB line.

ECONOMIZER CYCLE DECISION

Where 100% outdoor air economizer cycles are included with air handling systems, the decision of when to switch to the economizer mode is usually made automatically based upon the following criteria:

- The outdoor air conditions.
- The return air conditions or assumed conditions.
- The size and geographical location of the AHU.
- Cost.
- The users ability to understand control strategy and maintain the humidity sensors.

The economizer decision does not enable or disable chiller periods of operation. Chillers are generally enabled anytime chilled water valves

open. At economizer changeover, the OA (containing less heat than the RA) is intended to reduce the load on the cooling coil until no chilled water is required.

The OA sensors should generally be located at least two meters above the ground in the shade (north side) in a perforated enclosure away from exhausts.

Following are several popular strategies with guidelines of when each is appropriate.

ECONOMIZER CYCLE DECISION—OUTDOOR AIR DRY BULB CONTROL

Functional Description

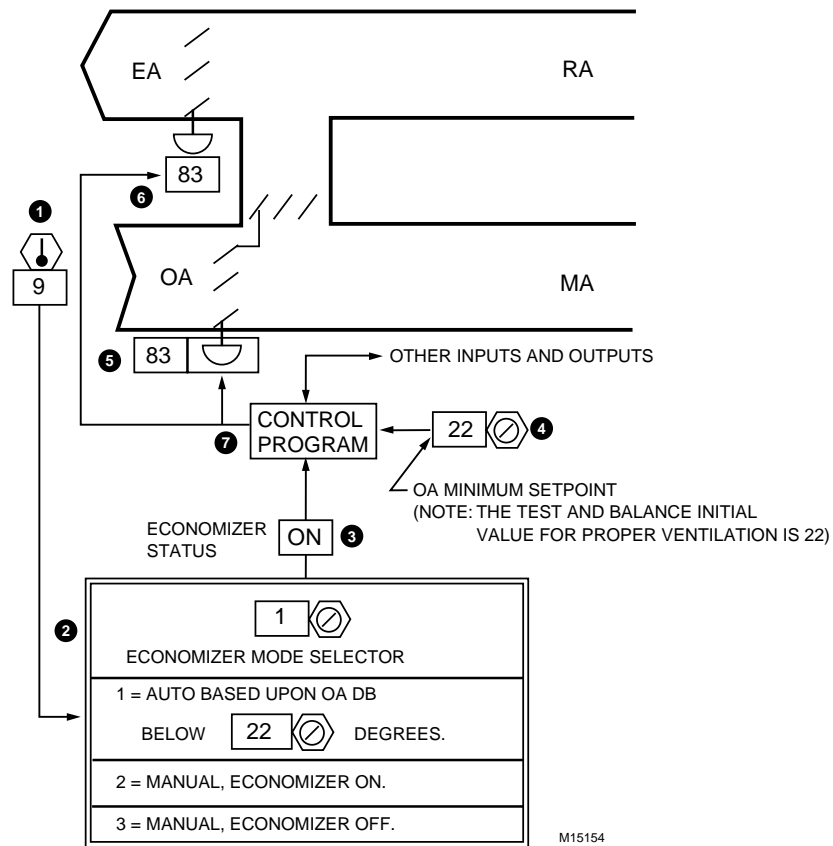

Item No.	Function
1	OA sensor senses OA temperature.
2	Economizer decision mode selector, including OA temperature setpoint below which the economizer decision is invoked, and command options.
3	Economizer decision status (operator information).
4	Setpoint for minimum OA damper position.
5	Actuator positions OA and RA dampers.
6	Actuator positions EA dampers.
7	Control program coordinates occupancy, temperature, smoke, and ventilation controls.

FEATURES

1. Outdoor air is used for cooling (or to supplement the chilled water system) anytime the OA temperature is below the economizer setpoint.
2. Stable, accurate, simple, electronic OA temperature sensor makes reliable economizer decision.
3. Economizer decision may be global and broadcast over the digital system network to other AHU systems.
4. Operator options for overriding the basic decision.
5. The test-and-balance minimum OA damper position initial value is provided as text. If the operator adjusts the minimum OA damper value, there is no longer a point of reference as to what it should be without this note.

CONDITIONS FOR SUCCESSFUL OPERATION

Local weather data analysis needed to determine the optimum changeover setpoint. The analysis need only consider data when

the OA is between approximately 16°C and 25.5°C, and during the occupancy period.

NOTE: The dry bulb economizer decision is best on small systems (where the cost of a good humidity sensor cannot be justified), where maintenance cannot be relied upon, or where there are not frequent wide variations in OA RH during the decision window (when the OA is between approximately 16°C and 25.5°C).

SPECIFICATIONS

A global economizer function shall be provided to switch all AHUs from OA cooling to minimum OA based upon an OA temperature setpoint. Software shall also be provided to allow the user to override the decision from being based upon OA dry bulb (with an appropriate commandable setpoint), to manually lock the system into or out of the economizer mode.

ECONOMIZER CYCLE DECISION—OUTDOOR AIR ENTHALPY CONTROL

Functional Description

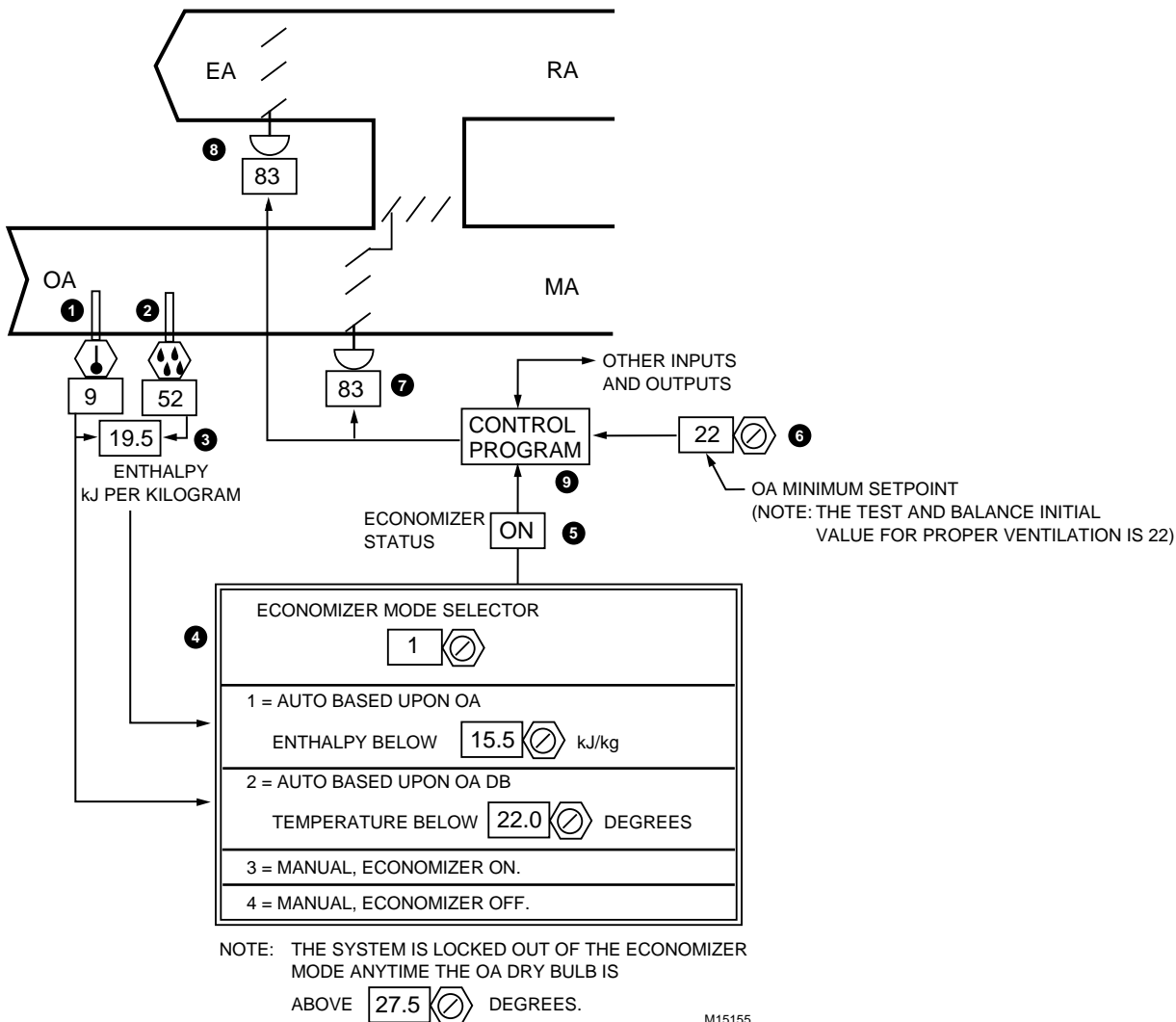

Item No.	Function
1	Sensor senses OA temperature.
2	Sensor senses OA humidity.
3	OA enthalpy calculated from OA temperature and humidity.
4	Economizer mode decision selector, including OA enthalpy setpoint below which the economizer decision is invoked, and command schedule.
5	Economizer decision status (operator information).
6	Setpoint for minimum OA damper position.
7	Actuator positions OA and RA dampers.
8	Actuator positions EA dampers.
9	Control program coordinates occupancy, temperature, smoke, and ventilation controls.

FEATURES

1. Outdoor air is used for cooling (or to supplement the chilled water system) anytime the OA enthalpy is below the economizer setpoint.
2. OA enthalpy considers total heat and will take advantage of warm dry low enthalpy OA and will block out cool moist OA, thus saving more energy than a dry-bulb based economizer loop.
3. Economizer decision should be global and broadcast over the digital system network to other AHU systems.
4. Operator options for overriding the basic decision and for selecting OA DB economizer changeover during periods of humidity sensor maintenance or failure..
5. The test-and-balance minimum OA damper positioned value is provided as text. If the operator adjusts the minimum OA damper value, there is no longer a point of reference as to what it should be without this note.

CONDITIONS FOR SUCCESSFUL OPERATION

1. A high quality RH sensor with at least 3% accuracy should be selected.
2. Periodic maintenance of the humidity sensor is provided.
3. An estimate of the typical return air enthalpy is needed to determine the optimum changeover setpoint.

NOTE: This OA enthalpy changeover decision is generally recommended unless the system falls into the range where OA dry bulb or OA/RA enthalpy comparison should be considered.

LIMITATIONS

A high dry-bulb limit setpoint should be included to prevent the enthalpy decision from bringing in air too warm for the chilled water coil to cool down.

SPECIFICATIONS

A global economizer program function shall be provided to switch all AHUs from OA cooling to minimum OA based upon an OA enthalpy calculation setpoint, except the system shall be locked out of the economizer mode anytime the OA DB is higher than 27.5°C. Software shall also be provided to allow the user to switch, with an appropriate commandable setpoint, the decision to be based upon OA dry bulb or to lock the system into or out of the economizer mode.

NOTE: The preceding graphic is an example of a major benefit of digital control systems. This graphic implies several enhancements over a simple economizer decision. It gives the user four economizer control software selectable options; an automatic OA enthalpy based economizer decision, an automatic OA dry bulb based economizer decision (for use if the OA RH sensor is bad), a manual economizer ON command (for use if the chiller plant is not ready to run for any reason), and a manual economizer OFF command (for use if the outdoor air is poor or a sensor malfunctions in the summer).

This enhanced scheme has the same program inputs (OA temperature, OA humidity) and the same output (the economizer decision status) as a basic OA enthalpy decision program. The enhancements are all software. After initial development and testing of the program (including the graphic development) this program can be cataloged, selected, and subsequently loaded on other projects for no appreciable additional cost over the basic program.

PSYCHROMETRIC ASPECTS

1. The following chart shows a comparison between an OA enthalpy and an OA DB economizer decision. For comparison, the enthalpy changeover setpoint is 67.5 kJ per kilogram of dry air (Line 3), and the dry bulb setpoint is 24°C (Line 4).
2. If the changeover decision is based upon enthalpy, the system will be in the economizer mode anytime the outdoor air lies in the area below Line 3 and to the left of Line 6.
3. If the changeover decision is based upon dry bulb temperature, the system will be in the economizer mode anytime the outdoor air lies to the left of Line 4.
4. Area 1 contains high enthalpy, low temperature air that would be used for free cooling if the decision was based upon OA dry bulb. This excess enthalpy would burden the chiller unnecessarily.
5. Area 6 contains low enthalpy, high temperature air that would be not used for free cooling if the decision was based upon OA dry bulb. This low enthalpy would reduce the chiller load.

6. Line 3 represents the dry bulb value, to the right of which the cooling coil could not handle the sensible load, no matter how dry the air is. This is the high temperature economizer cutout line used with the enthalpy and OA/RA enthalpy comparison economizer decision.

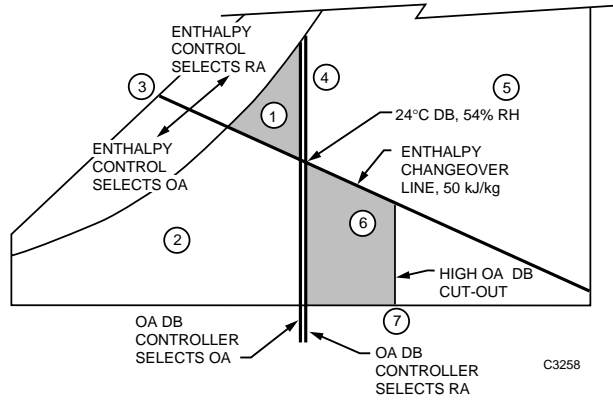

ECONOMIZER CYCLE DECISION—OUTDOOR AIR/RETURN AIR ENTHALPY COMPARISON

Functional Description

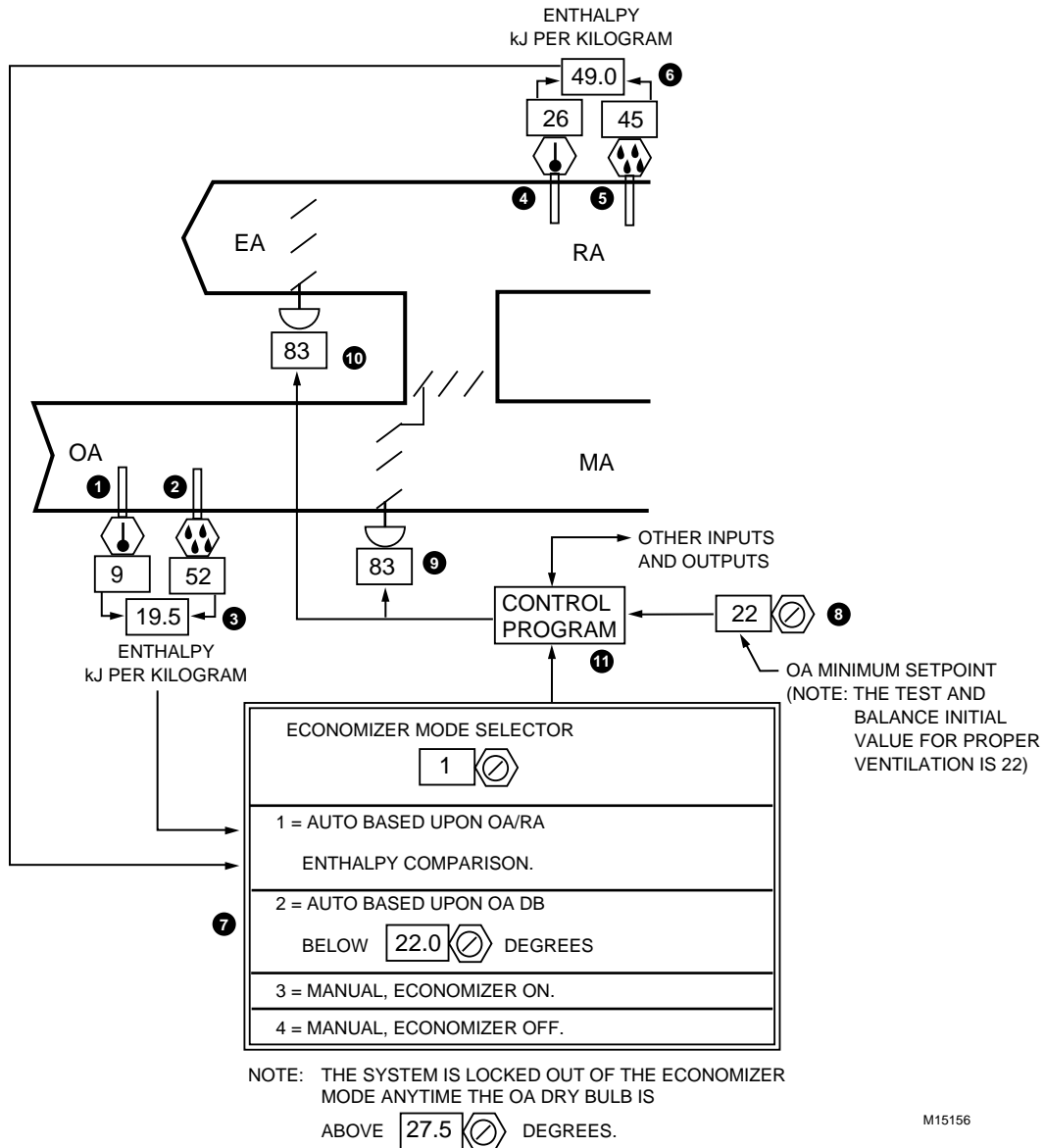

Item No.	Function
1	Sensor senses OA temperature.
2	Sensor senses OA humidity.
3	OA enthalpy calculated from OA temperature and humidity.
4	Sensor senses RA temperature.
5	Sensor senses RA humidity.
6	RA enthalpy calculated from OA temperature and humidity.
7	Economizer mode selector and command schedule.
8	Setpoint for minimum OA damper position.
9	Actuator positions OA and RA dampers.
10	Actuator positions EA dampers.
11	Control program coordinates occupancy, temperature, smoke control, and ventilation controls.

FEATURES

1. Outdoor air is used for cooling (or to supplement the chilled water system) anytime the OA enthalpy is less than the RA enthalpy.
2. Enthalpy considers total heat and will consider variations in OA and RA moisture content, thus saving more energy than dry-bulb based and OA enthalpy economizer loops.
3. The OA enthalpy calculation should be global and broadcast over the digital system network to other AHU systems.
4. Operator options for overriding the basic decision and for reverting to an OA DB economizer decision.
5. The test-and-balance minimum OA damper position value is provided as text. If the operator adjusts the minimum OA damper value, there is no longer a point of reference as to what it should be without this note.

CONDITIONS FOR SUCCESSFUL OPERATION

1. High quality RH sensors with at least 3% accuracy and long term stability should be selected.
2. Periodic maintenance of the humidity sensors is provided.
3. In some cases, only certain AHUs (which have varying latent loads) need RA enthalpy sensors and calculations, and others will be perform satisfactorily with OA enthalpy only. If RA moisture varies similarly on several AHUs, a single comparison and decision may be globally shared among them.

NOTE: The OA/RA enthalpy comparison decision is best on systems where the return air experiences wide swings in humidity when the OA temperatures are between approximately 16°C and 27°C. The size of the AHU should also be considered since savings will vary with fan airflow.

SPECIFICATIONS

An economizer decision function shall be provided to switch the AHU from OA cooling to minimum OA based upon an OA/RA enthalpy calculation and comparison. Anytime the OA enthalpy is below the RA enthalpy, the system shall switch to the economizer mode, except the system shall be locked out of the economizer mode anytime the OA DB is higher than 27.5°C. Software shall also be provided to allow the user to switch the economizer mode to an OA dry bulb base (with an appropriate commandable setpoint), or to lock the system into or out of the economizer mode.

**ECONOMIZER CYCLE DECISION—
OUTDOOR AIR/RETURN AIR DRY BULB
TEMPERATURE COMPARISON**

This rarely used economizer decision is similar to the enthalpy comparison but considers dry bulb temperatures only. This scheme is best on small systems if return air temperatures vary significantly when the OA temperatures are between approximately 16°C and 27°C.

PSYCHROMETRIC ASPECTS

In the following chart it is assumed that:

1. The manual positioning setpoint value provides 25 percent minimum OA.
2. The MA controller is set at 13°C.
3. The OA controller closes the OA damper to the minimum position when OA temperature is 27°C.
4. RA condition is 24°C DB and 15°C WB for winter; 27°C DB and 18°C WB for summer.
5. OA condition is 1.5°C DB and -1.5°C WB for winter; 38°C DB and 23.5°C WB for summer.
6. Other components exist in the complete system which hold the RA at the desired condition.

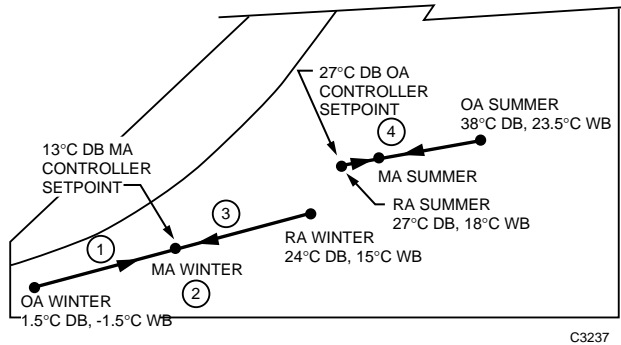

7. The desired MA temperature can be maintained during economizer periods until the OA temperature falls below the temperature at which only minimum OA is admitted if the OA is less than 13°C.

The following results are obtained:

Item No.	Explanation
1	At OA temperatures below -26°C DB (25 percent OA set by manual positioning setpoint value), the MA condition lies to the left of the 13°C DB line.
2	As the OA temperature varies between -26°C and 13°C, MA conditions lie on the 13°C DB line.
3	As the OA temperature varies between 13°C and 24°C, 100 percent OA is admitted and the MA lies in the area between 13°C and 24°C DB.
4	As the OA temperature rises above 27°C DB, the system operates on 25 percent OA and the MA temperature varies from 35°C to 29.5°C DB.

ECONOMIZER CYCLE CONTROL OF SPACE TEMPERATURE WITH SUPPLY AIR TEMPERATURE SETPOINT RESET

Functional Description

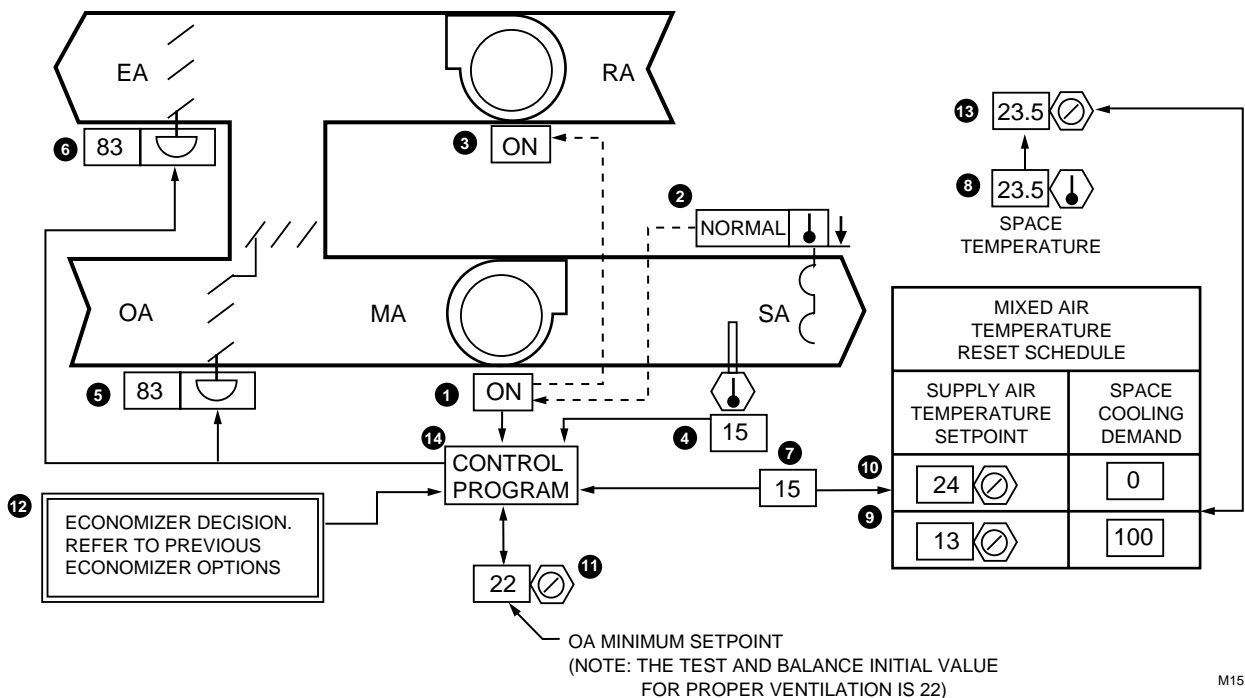

Item No.	Function
1-3	Control system energizes when fan is turned on (See FAN SYSTEM START-STOP CONTROL).
4	SA temperature maintained by modulating mixing dampers.
5,6	OA and EA dampers close and RA damper opens when fan is off and modulate for ventilation and temperature control when fan is on.
7	Setpoint for SA temperature control.
8	Space temperature demand resets SA temperature setpoint.
9,10	Calculates SA temperature setpoint (7) based upon space temperature cooling demand.
11	Setpoint value for minimum ventilation damper position.
12	Determines when OA is suitable to assist in cooling.
13	Space temperature setpoint and PID function. PID output (0 - 100) inputs to reset schedule.
14	Control program coordinates space temperature, SA temperature, minimum ventilation, fan interlock, and economizer control of mixing dampers.

FEATURES

1. The system admits only the minimum quantity of OA required for ventilation when the OA is unsuitable for cooling assistance.
2. During intermediate weather the system admits OA for cooling to satisfy the space temperature demands, subject to SA temperature schedule setpoints.
3. A minimum quantity of OA, determined by the software adjustable setpoint value, is assured at all times.

CONDITIONS FOR SUCCESSFUL OPERATION

1. Adequate mixing of OA and RA. Mixing may be obtained using a special mixing chamber. The temperature sensor should be in the fan discharge when possible. The fan in a blow-through system usually provides adequate mixing.
2. A satisfactory schedule of all settings must be determined.

LIMITATIONS

If the manual positioning value is set to admit a large quantity of OA and the OA temperature falls below the temperature at which only minimum OA is required for SA temperature control, a source of heat is necessary to maintain the SA temperature.

SPECIFICATIONS

See FAN SYSTEM START-STOP CONTROL.

Anytime the supply fan runs, the OA, exhaust, and RA dampers shall position to a minimum ventilation position and shall be further modulated by an SA PID control loop to maintain the SA temperature setpoint. The SA temperature setpoint shall be varied from no less than 13°C to no more than 24°C as the space temperature PID loop cooling demand varies from 100 to 0%. Anytime the economizer program is invoked, the SA temperature control shall be enabled.

PSYCHROMETRIC ASPECTS

For the psychrometric aspects of this application, refer to MIXED AIR CONTROL WITH ECONOMIZER CYCLE. The psychrometric aspects of the two applications are the same.

HEATING CONTROL PROCESSES

The following applications show various ways to control heating in an air conditioning system.

CONTROL FROM SUPPLY AIR

Functional Description

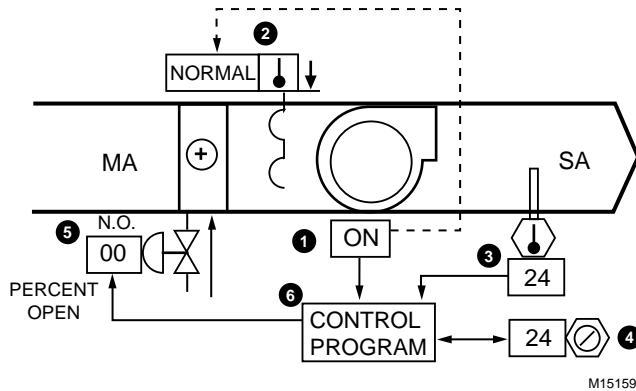

Item No.	Function
1-2	Control system energizes when fan is turned on (See FAN SYSTEM START-STOP CONTROL).
3,5	SA temperature maintained by modulating the hot water valve.
4	Setpoint for SA temperature control.
6	Control program coordinates temperature control and fan interlock.

FEATURES

1. Air is discharged at a minimum temperature.
2. Valve opens upon loss of motive force (electricity or compressed air) and closes upon fan shutdown.

CONDITIONS FOR SUCCESSFUL OPERATION

1. A multiple inline coil arrangement should be used if a high temperature rise is required.
2. Heating medium and flow must be available.

SPECIFICATIONS

See FAN SYSTEM START-STOP CONTROL.

Anytime the supply fan runs, the hot water valve shall be modulated by an SA PID control loop to maintain the SA temperature setpoint. The hot water valve shall close upon fan shutdown and open upon loss of motive force.

PSYCHROMETRIC ASPECTS

1. The SA temperature remains constant until the entering air temperature exceeds the desired SA temperature.
2. In the following chart it is assumed that the SA PID control loop is set at 24°C.

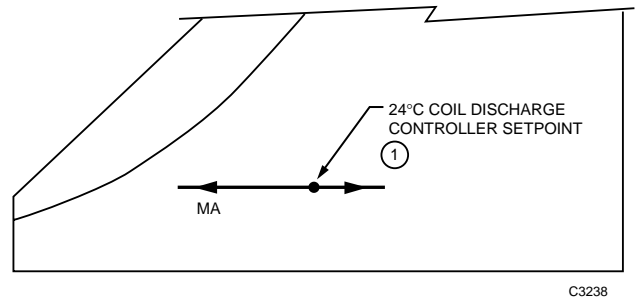

The following results are obtained:

Item No.	Explanation
1	Coil discharge is 24°C DB until MA exceeds 24°C DB, above which the coil valve is closed, no heat is added, and SA condition is equal to MA.

CONTROL FROM SPACE WITH SUPPLY TEMPERATURE RESET

Functional Description

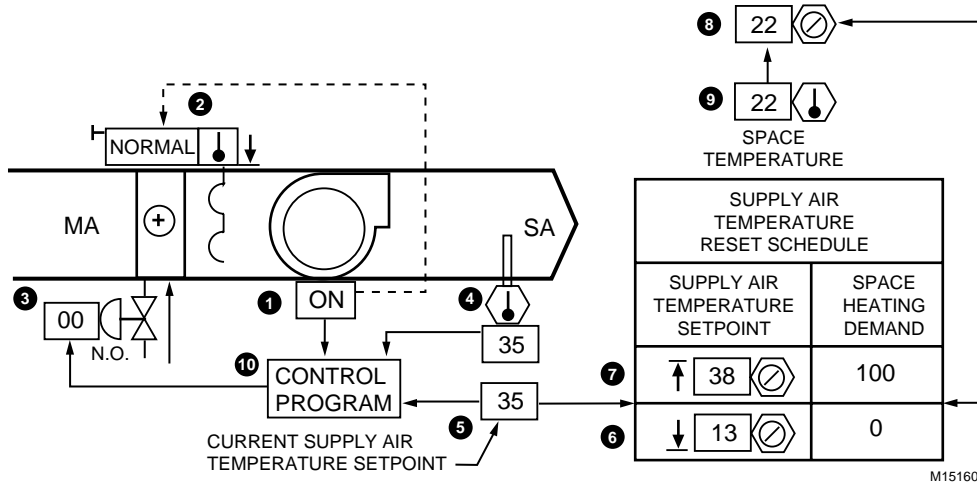

Item No.	Function
1-2	Control system energizes when fan is turned on (See FAN SYSTEM START-STOP CONTROL).
3	Hot water valve modulates heating medium.
4,5	SA temperature controlled to maintain setpoint.
6,7	SA temperature setpoint determined by space heating load.
8,9	Space temperature is compared to space temperature setpoint to determine SA temperature setpoint.
10	Control program coordinates temperature control and fan interlock.

- shall be reset from no lower than 13°C to no greater than 38°C as the space temperature PID demand for heating varies from 0% to 100%.
- The N.O. hot water valve shall close upon fan shutdown.

FEATURES

- Air is supplied at a temperature necessary to make up the sensible heat loss in the space.
- The SA temperature will not fall below a desired minimum or rise above a desired maximum (unless heating coil entering air rises).

CONDITIONS FOR SUCCESSFUL OPERATION

A multiple inline coil arrangement if a high temperature rise is required.

SPECIFICATIONS

See FAN SYSTEM START-STOP CONTROL.

- Anytime the supply fan runs, the hot water valve shall be modulated by an SA PID control loop to maintain the SA temperature setpoint. The SA temperature setpoint

PSYCHROMETRIC ASPECTS

The supply condition of the air depends on the condition of the entering air and the temperature rise needed to satisfy the space heating requirements.

In the following chart it is assumed that:

- The space temperature control loop is set at 24°C.
- MA condition is 10°C DB and 9°C WB.
- A space heating load exists which is large enough to require 35°C DB SA to meet the design condition heat loss.

The following results are obtained:

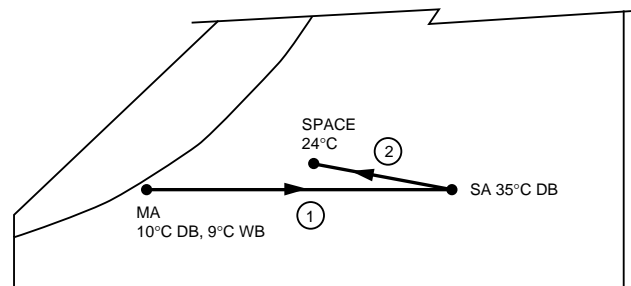

Item No.	Explanation
1	The heating of the MA to the supply temperature occurs along a line of constant moisture content.
2	Space air picks up moisture from the occupants and contents of the space.

OUTDOOR AIR TEMPERATURE RESET OF SUPPLY AIR TEMPERATURE

Functional Description

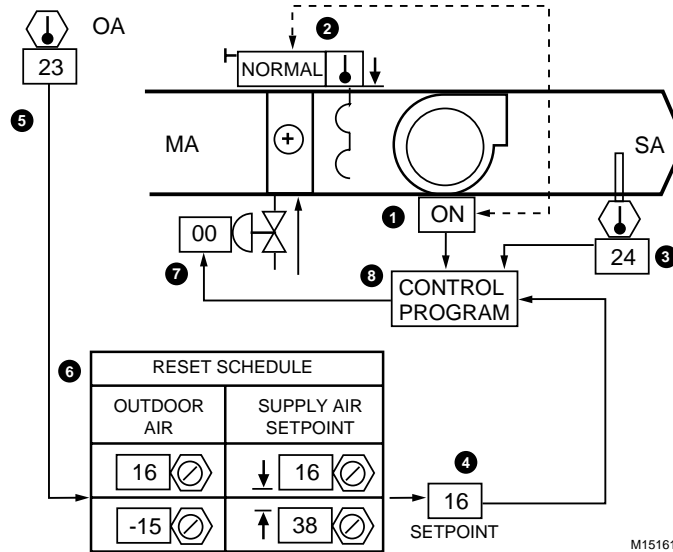

Item No.	Function
1,2	Control system energizes when fan is turned on (See FAN SYSTEM START-STOP CONTROL).
3,4	SA temperature setpoint, as adjusted by reset schedule, maintained by modulating hot water valve.
5,6	OA temperature resets the SA temperature setpoint according to a reset schedule.
7	Hot water valve modulates flow, opens upon loss of motive force, and closes upon fan shutdown.
8	Control program coordinates SA temperature, valve, and fan interlock control.

PSYCHROMETRIC ASPECTS

The SA condition depends on the entering air condition and the temperature rise needed to satisfy the space heating requirements.

In the following chart it is assumed that:

1. The MA system is set to maintain 16°C DB MA temperature.
2. The OA temperature reset controller increases the setpoint of the discharge PID control loop linearly from 16°C to 38°C DB as OA temperature falls from 16°C to -15°C DB.

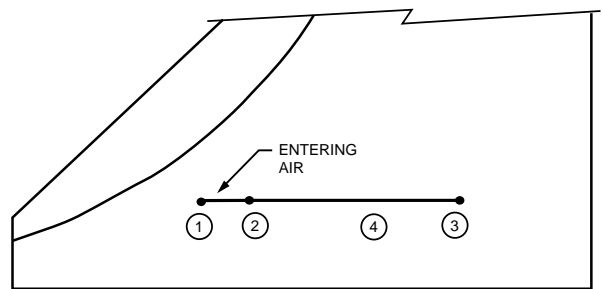

C2550-2

FEATURES

The SA temperature rises as the OA temperature falls according to a predetermined reset schedule.

CONDITIONS FOR SUCCESSFUL OPERATION

Use multiple inline coil arrangement should be used if a high temperature rise is required.

SPECIFICATIONS

See FAN SYSTEM START-STOP CONTROL.

Anytime the supply fan runs, heating control shall be enabled. A SA PID control loop shall modulate the hot water valve to maintain the SA temperature setpoint. The SA temperature setpoint shall be reset from 16°C to 38°C as the OA temperature varies from 16°C to -15°C.

The following results are obtained:

Item No.	Explanation
1	MA temperature.
2	SA at the beginning of the reset schedule.
3	SA heated to 38°C at outdoor design temperature.
4	Between -18°C and 16°C OA temperature, SA temperatures are between Points 2 and 3.

SPACE TEMPERATURE CONTROL OF ZONE MIXING DAMPERS AND RESET OF HOT DECK TEMPERATURE

Functional Description

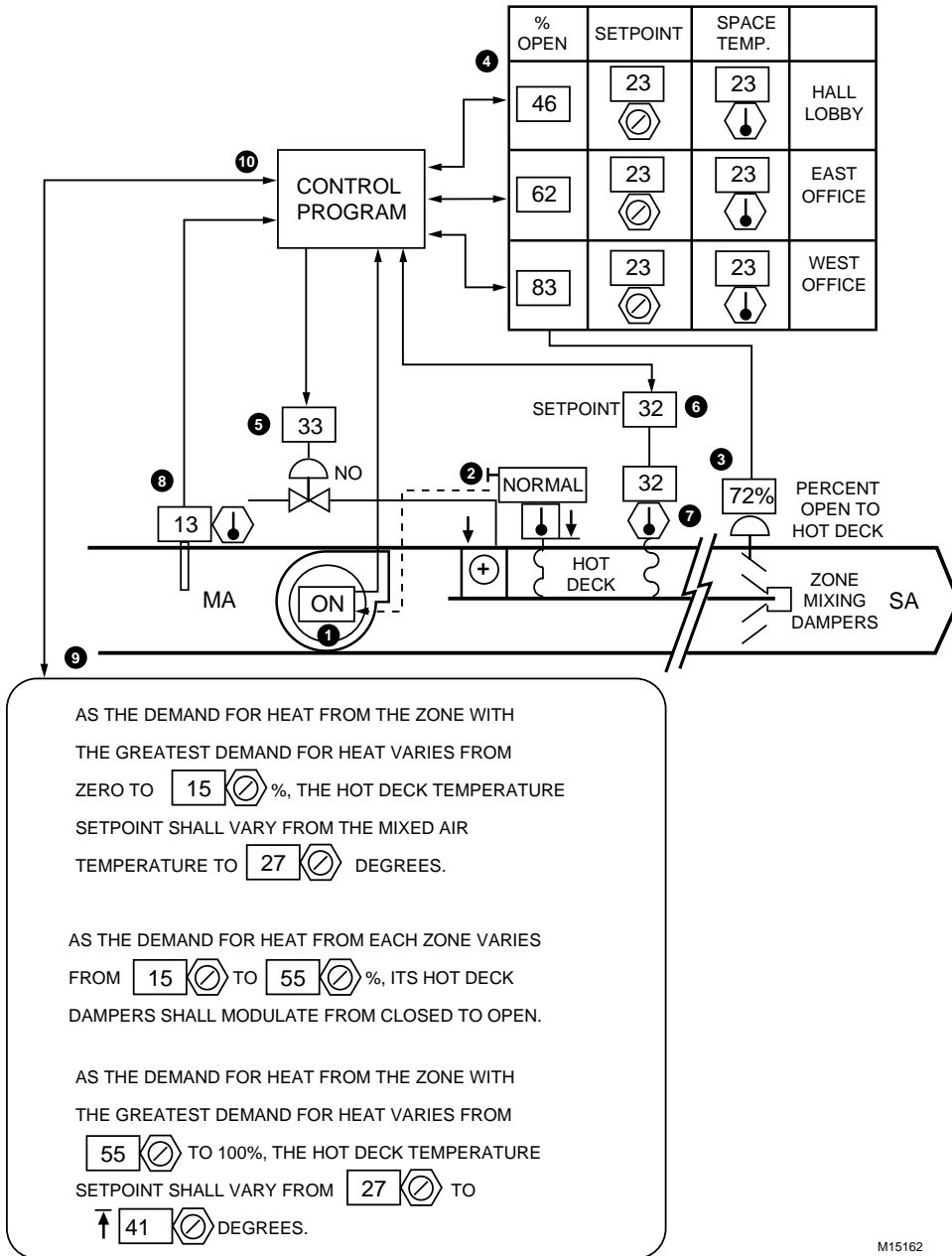

M15162

Item No.

Function

- | | | | |
|-----|---|----|---|
| 1-2 | Control system energizes when fan is turned on (See FAN SYSTEM START-STOP CONTROL). | 8 | MA temperature determines hot deck reset schedule start point. |
| 3-4 | Zone mixing dampers modulate to maintain zone temperature setpoint. | 9 | Dynamic graphic sequence display permits the operator to adjust program setpoints. Program adjusts hot deck temperature based upon operator inputs. |
| 5-7 | Hot water valve modulates to maintain hot deck temperature setpoint. | 10 | Control program coordinates load reset, temperature, and fan interlock programs. |

FEATURES

1. A motorized zone mixing damper and space temperature PID control loop for each zone provides zone control.
2. A single coil or group of coils in the hot deck furnishes heat for the entire system.
3. The hot deck temperature is reset by the zone with greatest load which provides efficient control when used in conjunction with a cold deck coil/control.
4. A reasonably constant volume of air is delivered to each room or zone.
5. A dynamic sequence-of-operation graphic display. This not only clearly explains the sequence but also allows easy program modification.

NOTE: Except for low-leakage OA dampers, measurable leakage usually exists through “closed” dampers. Given this leakage, as the zone heat demand increases from zero to 15%, the hot deck temperature setpoint is raised from the mixed air temperature to 27°C before any zone damper movement. Zone heating demand from 15 to 50% then modulates the zone dampers from zero to 100% open to the 27°C hot deck. Further zone heating demand from 50 to 100% raises the hot deck temperature setpoint from 27°C to the upper limit of 41°C. A major objective of this strategy is to minimize heat leakage to zones requiring no heat.

CONDITIONS FOR SUCCESSFUL OPERATION

1. A hot water coil on units having full flow at all times provides uniform hot deck temperatures. This can be accomplished with a three-way valve and coil pump. Resetting hot water temperature also helps.
2. All zones are connected to load the reset program to satisfy total load requirements. In large systems good practice dictates connecting only selected diverse zone loads. Zones that may be allowed to go out of control (storage rooms, etc.) should not be connected to the load reset program.
3. Each zone duct should have a balancing damper following the mixing dampers to ensure design volume to each zone.

NOTE: See the Microprocessor-Based/DDC Fundamentals section for a description of the load reset program.

LIMITATIONS

1. If only selected zones are connected to the load reset program, the load requirements of unconnected zones may not be satisfied.
2. Reduced steam flow may cause temperature gradients across the face of the coil.

SPECIFICATIONS

See FAN SYSTEM START-STOP CONTROL.

Anytime the supply fan runs, heating control shall be enabled.

Each zone mixing damper shall be modulated to maintain zone space temperature setpoint. The hot water valve shall be modulated to maintain the hot deck temperature setpoint.

The hot deck temperature setpoint shall be reset from the MA temperature to 27°C as the heating demand from the zone with the greatest heating demand varies from 0 to 15%.

Zone mixing dampers shall modulate from 0 to 100% open to the hot deck as their respective zone demands for heating vary from 15 to 55%.

The hot deck temperature setpoint shall be reset from 27°C to 41°C as the heating demand from the zone with the greatest heating demand varies from 55 to 100%.

PSYCHROMETRIC ASPECTS

In the following chart it is assumed that:

1. MA temperature is 13°C DB.
2. The zone with the greatest heating load requires a hot deck temperature of 32°C DB.
3. The zone depicted requires 24°C DB SA to meet its load.

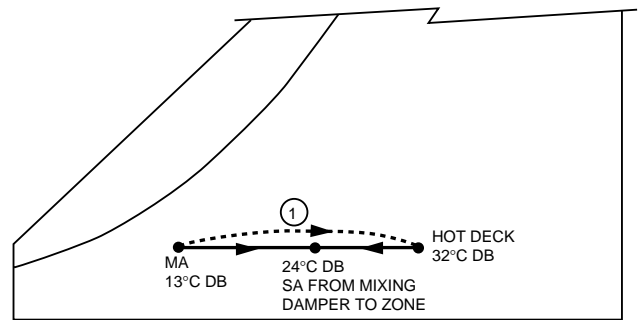

Item No.	Explanation
1	Heating of MA to the hot deck temperature occurs along a line of constant moisture content. Individual zones obtain any needed SA temperature along this line with the coldest zone controlling the hot deck temperature and getting 100 percent hot deck air.

PREHEAT CONTROL PROCESSES

The preheat process heats the air in preparation for subsequent conditioning. Preheat is sometimes necessary when high percentages of low temperature OA must be handled by the system. Considerations before a preheat component is installed in an air conditioning system are:

1. Preheat coils are often exposed to subfreezing temperatures. Provision to prevent freezing the coils must be made.

2. Accurate sizing of preheat coils is important. They should be sized so it is possible to allow OA for cooling yet not overheat the space.

In most of the following illustrations, preheat is shown in the OA preceding the mixing of OA and RA. In complete HVAC systems, the final preheat coil leaving air temperature setpoint should be dictated by demands for heating or cooling.

PREHEAT CONTROL WITH FACE AND BYPASS DAMPERS

Functional Description

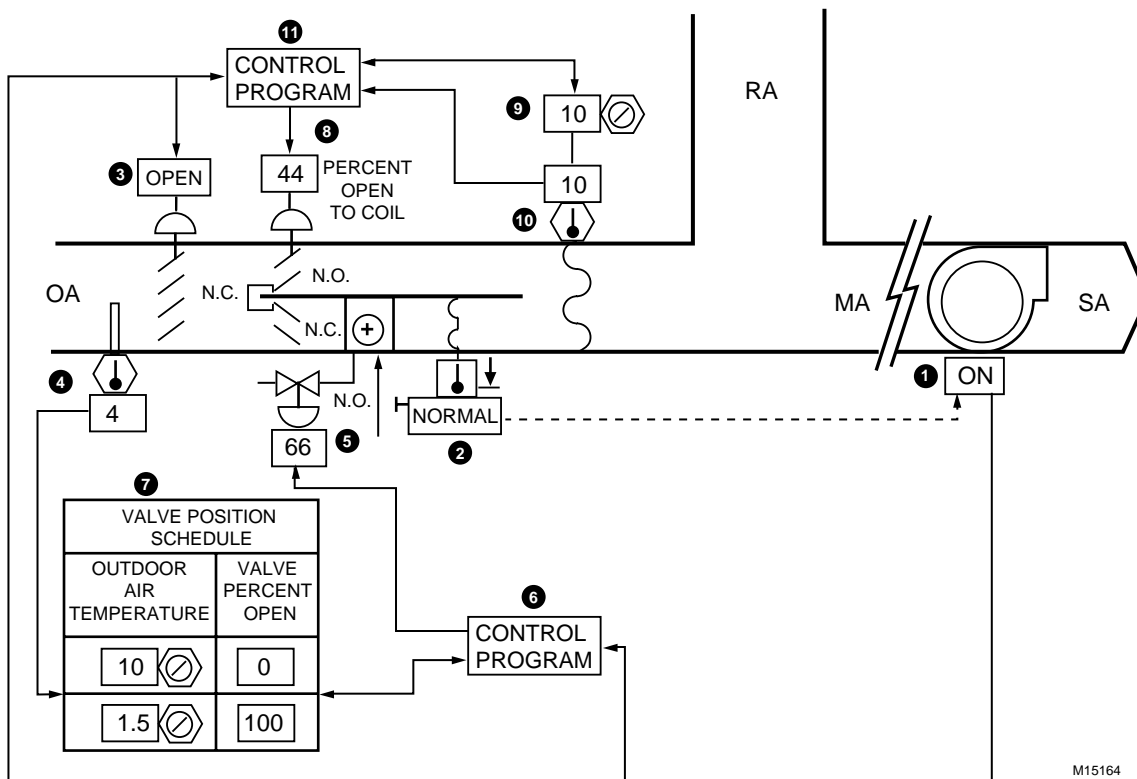

Item No.

Function

- | | | | |
|-----|---|------|--|
| 1-2 | Control system energizes when fan is turned on (See FAN SYSTEM START-STOP CONTROL). | 6 | Control program coordinates fan interlock and valve control. |
| 3 | OA damper opens on fan startup, closes upon fan shutdown (in some cases the OA damper may be part of a mixed air system). | 7 | Valve position determined by OA temperature. |
| 4 | OA temperature determines valve position. | 8-10 | Face-and-bypass dampers controlled to maintain face-and-bypass leaving air temperature setpoint. |
| 5 | Valve controls heating medium flow to coil. | 11 | Control program coordinates fan interlock and face-and-bypass damper control. |

FEATURES

1. Preheat coil conditions large quantities of low temperature OA before it enters the system.
2. Bypass damper controls temperature of air leaving the face-and-bypass section without endangering the preheat coil which operates in full valve open mode during freezing conditions.
3. Upon fan shutdown, valve controls at 38°C leaving air temperature in freezing weather and positions closed upon fan shutdown in non-freezing weather.

CAUTION: If steam (or very hot water) valves position full open during off periods, air temperatures may melt fire damper linkages.

CONDITIONS FOR SUCCESSFUL OPERATION

1. Preheat coil sized to raise a maximum quantity of OA from outdoor design temperature to 10°C.
2. Averaging element sensor positioned in face-and bypass air to sense average air temperature.
3. Bypass air well mixed with face (and return) air prior to entering down-stream water coils (additional low temperature controls may be required for down-stream water coils).
4. On large 100% OA systems the OA damper opens prior to fan start up to protect ducting from collapse.
5. The setpoint of air leaving the preheat section is usually dictated by the downstream AHU temperature controls.

SPECIFICATIONS

See FAN SYSTEM START-STOP CONTROL.

Anytime the supply fan runs, heating control shall be enabled, and the OA dampers shall open for ventilation requirements.

The heating coil valve shall open upon loss of actuator motive force, shall close upon fan shutdown if the OA temperature is above 1.5°C, and shall control to maintain 38°C leaving air temperature upon fan shutdown if the OA temperature is below 1.5°C.

The heating coil valve shall position from 0 to 100% open as the OA temperature varies from 10°C to 1.5°C. The face-and-bypass dampers shall modulate to maintain an average face-and-bypass leaving air temperature of 10°C.

PSYCHROMETRIC ASPECTS

In the following chart it is assumed that:

1. The coil has a temperature rise of 28 kelvins with full air flow –18°C air and a temperature rise of 39 kelvins with reduced air flow as in the example.
2. The coil water flow modulates from closed to open as OA temperature drops from 10°C to 1.5°C.
3. OA temperature is –1°C DB.

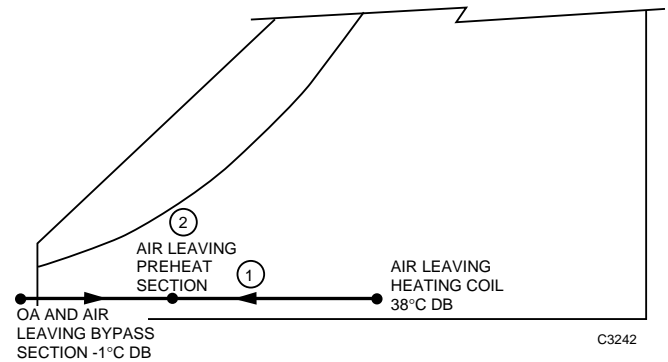

The following results are obtained:

Item No.	Explanation
1	Heating of OA occurs along a line of constant moisture content from –1°C to 38°C.
2	The PID control loop maintains the temperature of the preheat section leaving air.

CONTROL FROM PREHEAT LEAVING AIR

Functional Description

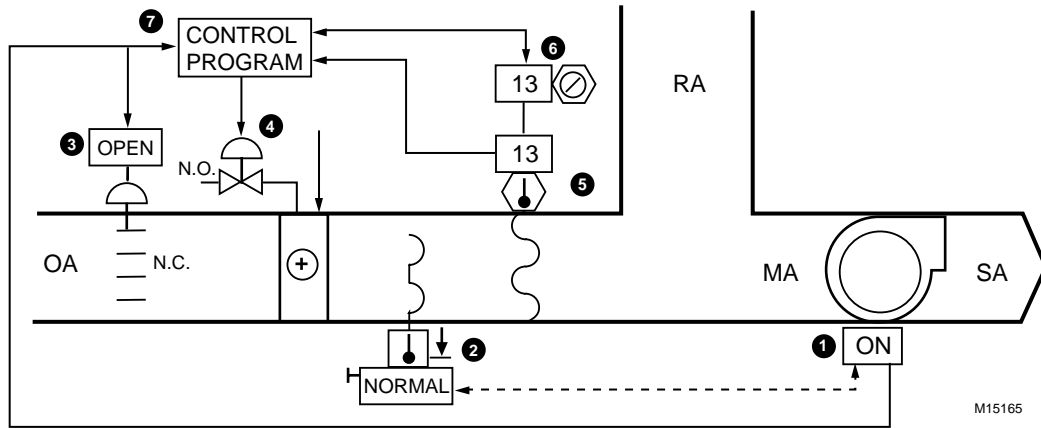

Item No.	Function
1-2	Control system energizes when fan is turned on (See FAN SYSTEM START-STOP CONTROL).
3	OA damper opens on fan startup, closes upon fan shutdown.
4-6	Heating valve modulates to maintain heating coil leaving air temperature setpoint.
7	Control program coordinates fan interlock and valve control.

LIMITATIONS

If too high a temperature rise is used, the valve may short cycle or slow down the water in the coil and allow the coil to freeze.

SPECIFICATIONS

See FAN SYSTEM START-STOP CONTROL.

Anytime the supply fan runs, heating control shall be enabled, and the OA dampers shall open for ventilation requirements. The heating coil valve shall be modulated by a PID control loop to maintain the coil leaving air temperature setpoint.

The heating coil valve shall open upon loss of actuator motive force, shall close upon fan shutdown if the OA temperature is above 1.5°C, and shall control at a leaving air temperature setpoint of 38°C upon fan shutdown if the OA temperature is below 1.5°C.

FEATURES

1. A preheat coil conditions large quantities of low temperature OA before it enters the system.
2. A fixed amount of OA for ventilation is delivered whenever the fan is on.

CONDITION FOR SUCCESSFUL OPERATION

1. The temperature is limited to a value low enough to have the coil valve full open at freezing temperatures.
2. Water temperature reset and/or a recirculating pump is very helpful in keeping high flow at varying OA temperatures. If a large temperature rise is required, use an arrangement of multiple inline coils.
3. The control network sends a command to start the hot water system anytime the hot water valve is not closed.

NOTE: If a variable flow hot water system exists, it may be preferable to have the hot water valve position to approximately 25% open (rather than full open) upon fan shutdown in freezing weather. This saves pump energy and often prevents the need for multiple pumps.

PSYCHROMETRIC ASPECTS

The coil discharge and MA conditions can be distributed over considerable area on the psychrometric chart depending on the entering air condition and the temperature rise through the coil.

In the following chart it is assumed that:

1. The preheat coil has a temperature rise of 19 kelvins.
2. The preheat coil valve modulates to maintain leaving air temperature.
3. RA condition is 24°C DB and 17°C WB.
4. The MA is composed of 50 percent preheated air and 50 percent RA.
5. OA condition is 1.5°C DB and -1.5°C WB (design).

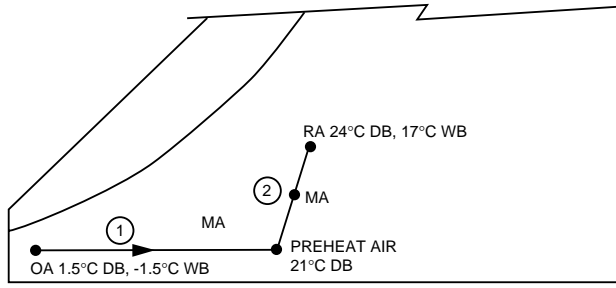

C3243

The following results are obtained:

Item No.	Explanation
1	Heating of OA occurs along a line of constant moisture content from 1.5°C to 21°C.
2	This condition represents the mixing of preheated air and RA supplied to the system.

MULTIPLE COIL CONTROL FROM OUTDOOR AND SUPPLY AIR

Functional Description

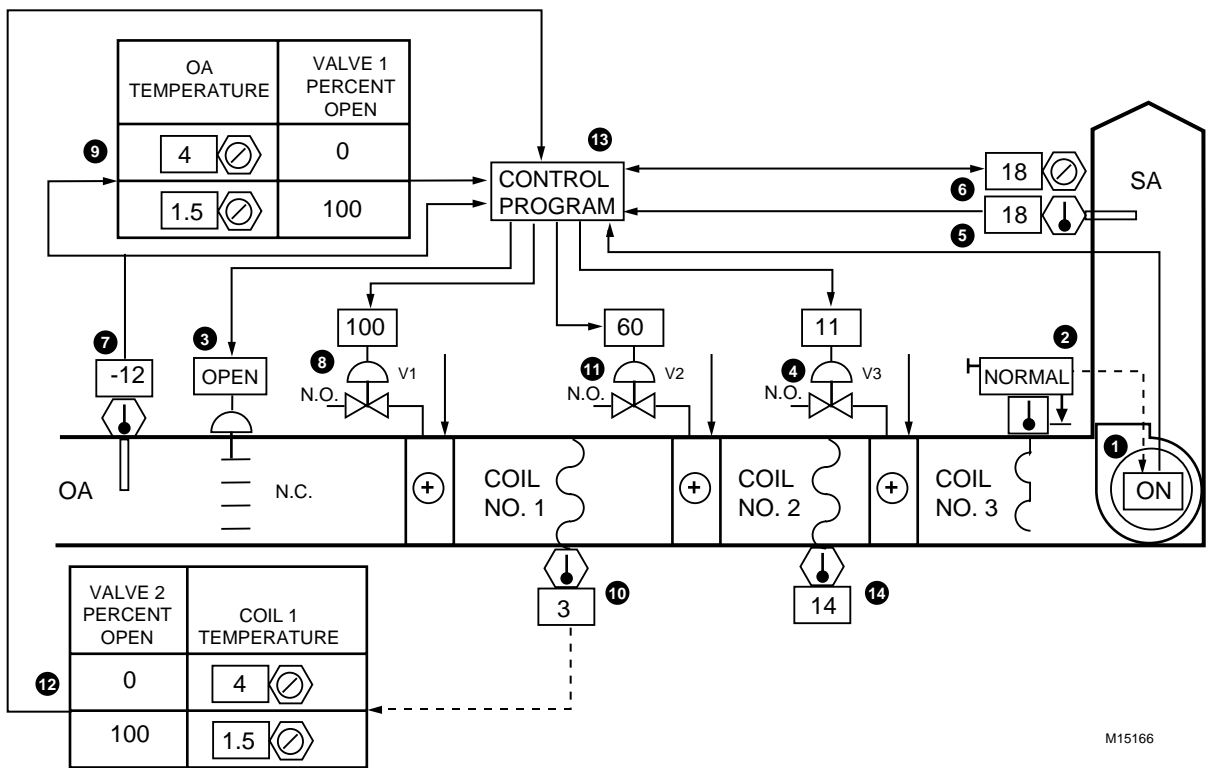

M15166

Item No.	Function
1,2	Control system energizes when fan is turned on (See FAN SYSTEM START-STOP CONTROL).
3	OA damper opens when fan runs.
4-6	Supply air PID control loop modulates the coil #3 valve to maintain constant supply temperature.
7-9	Coil #1 is under open loop control by OA temperature.
10-12	Coil #2 is under open loop control by coil #1 leaving air temperature.
13	Control program coordinates temperature, ventilation, and fan interlock control.
14	Coil #2 leaving air temperature is for operator information (unless alarm monitoring is desired).

FEATURES

1. The multiple inline coil system heats below-freezing air with little danger of freezing the coils or overheating the space.
2. The supply temperature is constant (or may be dictated by other HVAC controls).
3. In this sequence, individual Coil 1 and 2 Valves are opened fully just before freezing air enters to prevent freezing.
4. The low temperature control (Item 2) is intended to protect the coils from freezing due to the loss of heat. Low temperature controls cannot be installed in the leaving air of Coils 1 and 2 because leaving air temperatures below freezing may be normal. If water flow is lost through Coils 1 or 2, they could freeze without detection by the low temperature control (Item 2). Differential temperature (software) monitor points across

Coils 1 and 2 could be added to detect the loss of heating. If a Building Management System is included, the monitor could be two-stage to send an alarm warning message if the coil entering air temperature is less than 0°C and the differential temperature is less than 12 kelvins, and shut the system down if the differential temperature is less than 10 kelvins. If the hot water temperature is reset, or if the design OA temperature is less than -18°C, the two differential temperature alarm values should increase as the coil entering air temperature decreases. Temperature sensors in the coils leaving water may also detect freezing danger. The numbers “22” and “18” are arbitrary and must be carefully determined if protection is to be achieved.

CONDITIONS FOR SUCCESSFUL OPERATION

1. Heating Coils 1 and 2 should provide approximately the same temperature rise and keep the air entering Coil 3 above freezing. Do not oversized any of the coils. The rise for Coils 1 & 2 (which are full open at 1.5°C entering air temperature) should be selected to produce no more than the maximum leaving air temperature that can be tolerated.
2. Coil 3 should be sized for the balance of the heating load.
3. Follow good piping practices to avoid freezing steam coils.
4. On large systems, fan start signal should open the OA damper, and a damper end switch should start the fan (to prevent the ductwork from collapsing before the damper can open).

SPECIFICATIONS

See FAN SYSTEM START-STOP CONTROL.

Anytime the supply fan runs, heating control shall be enabled and the OA dampers shall open for ventilation requirements.

The heating Coil 1 valve shall open upon loss of actuator motive force, shall close upon fan shutdown if the OA temperature is above 1.5°C, and shall open upon fan shutdown if the OA temperature is below 1.5°C. Heating Coils 2 and 3 valves shall open upon loss of actuator motive force and shall close upon fan shutdown.

The Heating Coil Valve 3 shall be modulated by a PID control loop to maintain the leaving air temperature setpoint.

The valve to Coil No. 1 (nearest entering air) shall position from 0% to 100% open as the OA temperature varies from 4°C to 1.5°C.

The valve to Coil No. 2 shall position from 0% to 100% open as the air temperature leaving Coil 1 varies from 4°C to 1.5°C.

OPTIONAL: Anytime the Coil 1 valve is full open and the Coil 1 air differential temperature is less than a Value V1, an alarm message shall be issued. Anytime the Coil 1 valve is full open and the Coil 1 air differential temperature is less than a Value V2, the fan system shall shut down until manually reset. The Value V1 shall vary from 20 to 24 as the OA temperature varies from -1°C to -23°C. Value V2 shall equal V1 minus 4. A similar monitor and alarm function shall be provided for Coil 2.

PSYCHROMETRIC ASPECTS

This application is of greatest use in a 100 percent OA system. The SA conditions can lie anywhere along the line of the desired DA dry-bulb temperature.

In the following chart it is assumed that:

1. The system handles 100 percent OA.
2. The supply air PID control loop is set at 21°C.
3. Design OA temperature is -29°C.
4. Temperature rises through coils: Coil 1 = 16 kelvins; Coil 2 = 16 kelvins; Coil 3 = as required for the balance of the heating load.
5. OA temperature is 1.5°C DB.

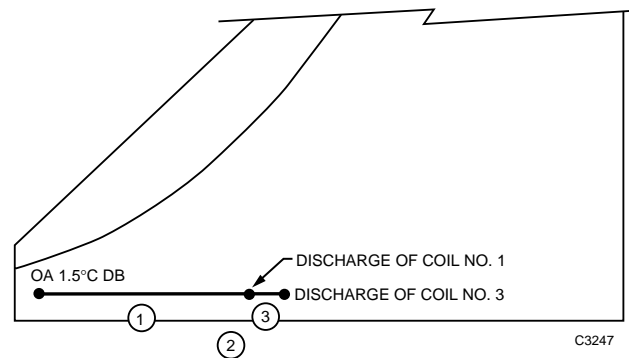

The following results are obtained:

Item No.	Explanation
1	Coil No. 1 is providing 100 percent capacity raising the entering air from 1.5°C to 18°C.
2	Coil No. 2 valve is closed.
3	Coil No. 3 is modulating and provides a 2.5 kelvins temperature rise to the desired supply temperature.

YEAR-ROUND HEAT RECOVERY PREHEAT SYSTEM CONTROL

Functional Description

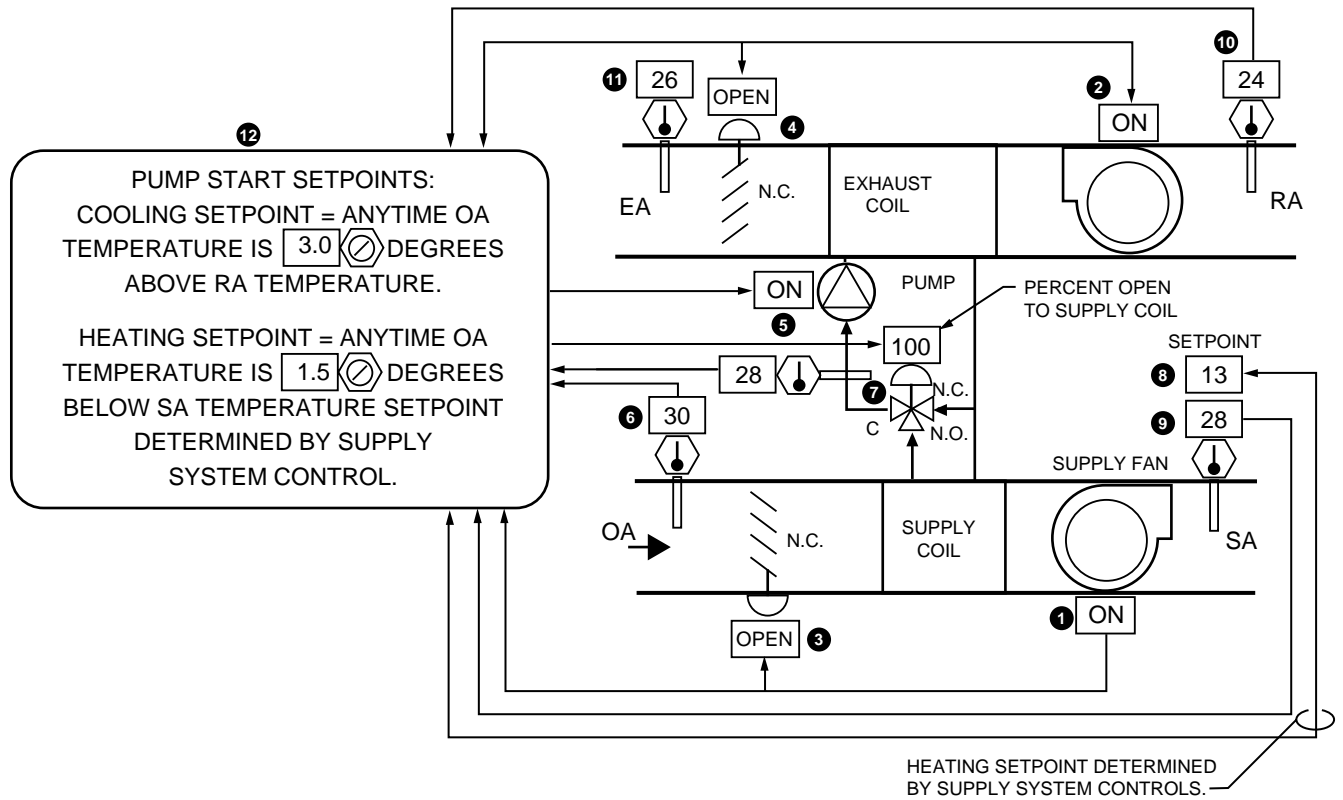

M15167

Item No.	Function
1,2	Fans start and enable pump control upon HVAC demand for ventilation (See FAN SYSTEM START-STOP CONTROL).
3,4	Dampers close upon fan shutdown.
5	Pump runs when temperature conditions are suitable for beneficial results.
6,10	The OA and RA temperature difference determines when pump operation is beneficial.
7	Mixing valve prevents too much RA heat from being transferred such that the SA temperature exceeds that demanded by the HVAC control system. Mixing valve also keeps water entering the exhaust coil from dropping below freezing to prevent the coil from frosting.
	HVAC system SA temperature setpoint determines valve position in winter.
	Operator information.
	Dynamic graphic sequence display permits the operator to adjust program setpoints.

FEATURES

1. Use of the heat recovery system makes it energy efficient to use 100 percent OA by transferring heat from RA to supply air during heating operation and transferring cooling from RA to supply air during cooling operation.
2. This system can be used to preheat air for an MA system or as a 100% OA system.

CONDITIONS FOR SUCCESSFUL OPERATION

1. A non-freezing medium should be circulated between coils.
2. Heat recovery pump should be shut down during periods when low OA and RA differentials exist and when the HVAC system demands for free cooling are not exceeded by cool OA.
3. Improved control under heating light load conditions may be obtained with an SA PI control loop and a three-way valve. Since the exhaust temperature is never low enough to satisfy the cooling demand, the valve should not bypass the coil during cooling operation.
4. Entering air to each coil may require filtration to keep heat transfer coefficients high.
5. Building exhaust must be centralized.
6. If, after heat recovery, the SA is still below setpoint, a heat exchanger may be added to increase water temperature to the supply coil.

NOTE: This reduces the recovery system efficiency by lowering the differential temperature between the water and OA.

SPECIFICATIONS

OA and exhaust fans shall start, their OA dampers open, and the water flow and temperature controls shall be enabled anytime the HVAC system requires OA.

In the cooling season, the recirculating pump shall run with full flow in the coils anytime the OA temperature is greater than six degrees above the RA temperature.

In the heating season, the recirculating pump shall run anytime the OA temperature is less than three degrees below the supply fan SA temperature setpoint.

A pump inlet mixing valve shall be modulated during heating operation if necessary to prevent the supply fan DA temperature from rising above its setpoint (determined by the HVAC system demands). The mixing valve shall also modulate to prevent the exhaust coil entering water temperature from falling below 0°C to prevent the coil from frosting.

PSYCHROMETRIC ASPECTS

In the following chart it is assumed that:

1. The three-way valve is full open to the coil because the exhaust air heat does not exceed the supply coil heat requirements.
2. The heat recovery pump is operating.
3. Heating RA condition is 24°C DB and 17°C WB.
4. OA temperature is 1.5°C DB and -1.5°C WB.

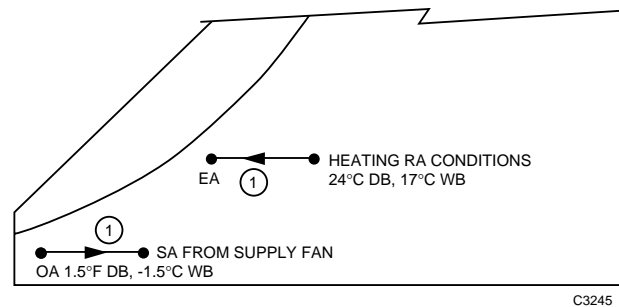

The following results are obtained:

Item No.	Explanation
1	Temperature rise of the SA coil and temperature drop of the EA coil are a function of system design, flow rates, and component efficiency. A 8 kelvins rise is shown as an example.

HUMIDIFICATION CONTROL PROCESS

Humidification is a process of adding moisture to air. The most commonly used humidifier type is the steam jet. Humidifier requirements vary; check manufacturers recommendations.

Although steam jet humidifiers are depicted, other modulating types control similarly. On-off humidifiers require a differential in addition to a setpoint.

Generally, humidifiers should be locked off during periods of mechanical cooling.

CONTROL OF MODULATING HUMIDIFIER

Functional Description

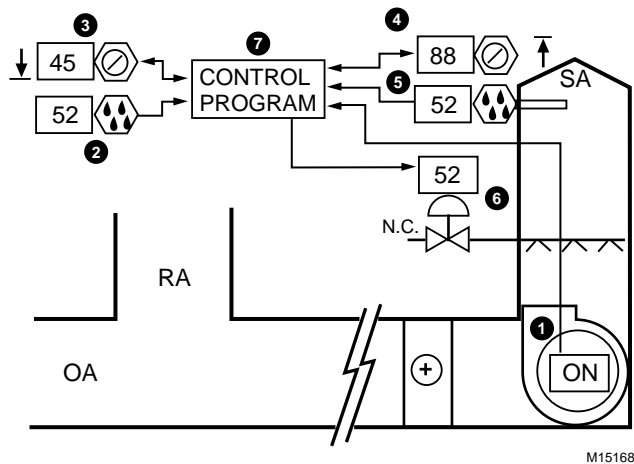

Item No.	Function
1	Control system energizes when fan is turned on (See FAN SYSTEM START-STOP CONTROL).
2,3	Space humidity PI control modulates the humidifier to maintain the minimum space relative humidity setpoint.
4,5	Humidifier leaving air humidity high limit proportional control modulates humidifier off, if necessary, to prevent relative humidity from exceeding the setpoint.
6	Humidifier is off whenever the fan is off.
7	Control program coordinates digital control loops and fan interlock.

CONDITIONS FOR SUCCESSFUL OPERATION

1. The steam pressure to the valve is kept at a constant value between 35 and 85 kPa.
2. The air passing through the humidifier is warm enough to absorb the required amount of moisture. The best humidifier location is after a heating coil.
3. The high-limit humidistat is set relatively high, about 90 percent relative humidity.
4. If the digital controller is in a network and the OA temperature value is available, the comfort humidification system is disabled when the OA temperature is above a summer value (18°C).
5. Check recommended applications for specific humidifier furnished.
6. Where humidifiers have a separate steam jacket, a separate valve may be added to shut down the jacket steam during prolonged off periods to minimize heat loss. The jacket keeps the humidifier hot so when humidification is required, the humidifying steam does not condense inside the humidifier and enter the duct as water.

FEATURES

1. Moisture is added with only a slight increase in dry bulb temperature (steam humidifier).
2. Humidification is turned off when the fan is stopped to prevent accumulation of moisture in the ducts.
3. Duct humidity high-limit keeps air below saturation moisture-condensing point.

SPECIFICATIONS

1. The humidifier shall be modulated by a space humidity PI control loop to maintain the humidity setpoint.
2. A humidifier leaving air humidity high limit control loop shall disable the humidifier if the humidity rises above the high-limit setpoint.
3. The humidifier shall be off upon loss of actuator motive force and when the fan is off.

PSYCHROMETRIC ASPECTS

The steam humidification process is almost isothermal.

In the following chart it is assumed that:

1. Space conditions are 22°C and 45% RH.
2. Mixed air (entering the heating coil) is 16°C and 6°C DP.
3. Additional moisture required to maintain space conditions is 3.0 grams per kg of dry air.

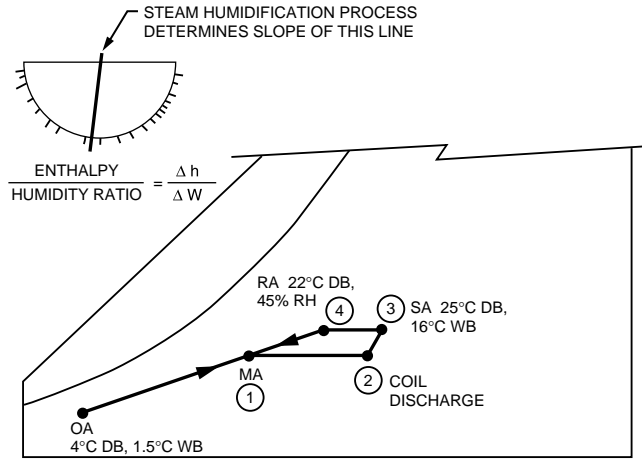

C3248

Item No.

Explanation

- | | |
|---|---|
| 1 | RA and dry OA mix and enter a heating coil. |
| 2 | Heating coil leaving air; air gains sensible heat. |
| 3 | Humidifier leaving air; air gains mostly latent heat. |
| 4 | RA; cooled via heat loss and humidity reduced. |

COOLING CONTROL PROCESSES

The following are common control arrangements for cooling.

CONTROL OF MODULATING CHILLED WATER COIL THREE-WAY VALVE

Functional Description

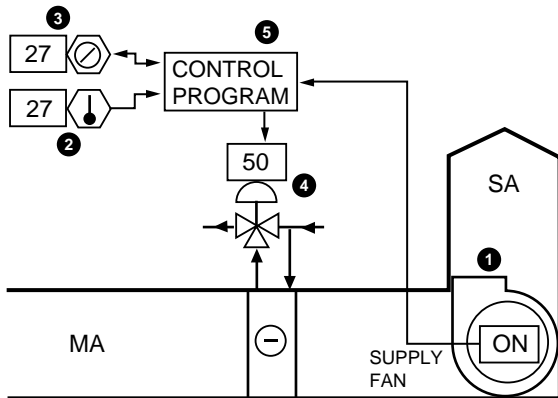

M15169

Item No.

Function

- | | |
|------|--|
| 1 | Control system energizes when fan is turned on (See FAN SYSTEM START-STOP CONTROL). |
| 2, 3 | Space temperature PID control loop modulates the three-way valve to maintain space temperature setpoint. |
| 4 | Chilled water valve directs flow through or around coil as needed to furnish proper amount of cooling. |
| 5 | Control program coordinates temperature control and fan status. |

FEATURES

1. Chilled water is supplied to the coil at a constant temperature and varying volume.
2. A reasonably constant flow is maintained through the entire piping system.

CONDITION FOR SUCCESSFUL OPERATION

The water must be supplied at a reasonably constant pressure.

LIMITATIONS

Modulating water flow through a constant air volume chilled water coil usually causes a rise in space RH because the coil leaving water temperature rises significantly.

SPECIFICATIONS

The flow of chilled water through the cooling coil shall be controlled by a three-way valve modulated by a space temperature PI control loop. The valve shall close to the coil upon fan shutdown and open to the coil upon loss of actuator motive force.

PSYCHROMETRIC ASPECTS

The temperature, and often moisture content, of leaving air increases as the sensible cooling load lightens.

In the following chart it is assumed that:

1. Desired space and RA condition is 25°C DB and 50% RH (18°C WB).

2. Design OA temperature is 35°C DB and 24°C WB.
3. Air entering the system is from the ECONOMIZER CYCLE DECISION application. This system operates on 35 percent OA during the cooling cycle.
4. Coil discharge temperature is 13°C.

The following results are obtained:

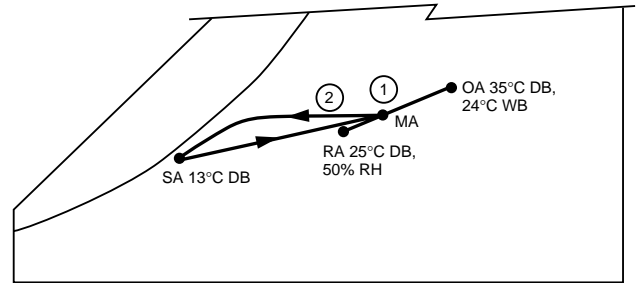

C3249

Item No.

Explanation

- | | |
|---|---|
| 1 | Mixed air temperature at cooling design condition. |
| 2 | Air entering the coil is cooled along a line of constant moisture content until saturation is approached. Near saturation the moisture content is reduced as the air is cooled. This process involves both latent and sensible cooling. |

NOTE: Condition of coil leaving air will change with the cooling load in the space. As the cooling load decreases, the three-way valve will provide less chilled water flow to the coil and the discharge air temperature will rise (approximately along Line 2).

TWO-POSITION CONTROL OF DIRECT EXPANSION COIL SYSTEM

Functional Description

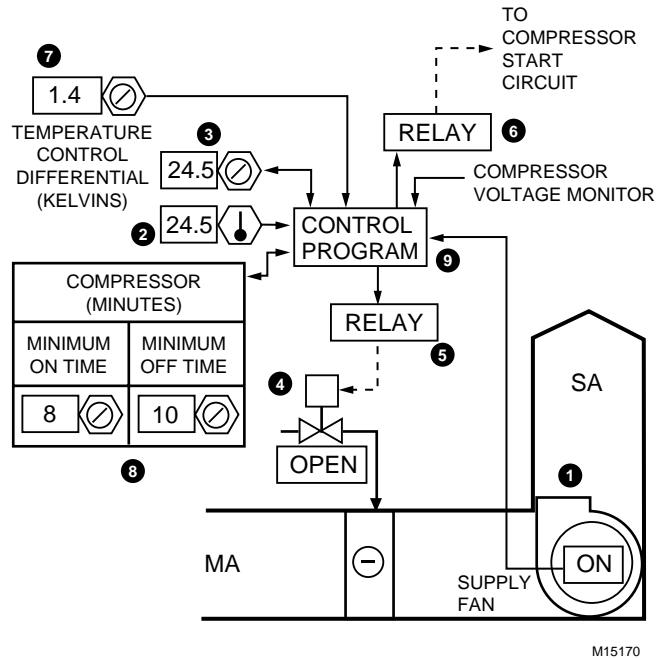

Item No.

Function

- 1 Control system energizes when fan is turned on (See FAN SYSTEM START-STOP CONTROL).
- 2 Space temperature inputs to control program.
- 3 Setpoint determines refrigerant on mode.
- 4 Refrigerant solenoid valve closes when fan is off.
- 5 Relay controls liquid line solenoid valve.
- 6 Relay enables compressor start control system.
- 7 Temperature differential determines compressor off mode.
- 8 Compressor minimum on and minimum off times prevent short cycling.
- 9 Control program coordinates cooling, safety, and fan interlock control.

LIMITATIONS

1. Direct expansion coils are difficult to control from leaving air due to the large and rapid temperature drop when energized.
2. Compressor operating and safety controls must be incorporated into the control system.

SPECIFICATIONS

See FAN SYSTEM START-STOP CONTROL.

The DX control system shall be enabled anytime the fan operates.

Cooling system shall be cycled by a temperature control loop with a 1.4 kelvins (adjustable) differential to maintain the space temperature setpoint. When the system is commanded on by the control program, it shall remain on at least eight minutes, and when it is commanded off (or drops off during power interruptions) it shall remain off at least ten minutes.

On a rise in space temperature to the setpoint, the refrigerant liquid line valve shall open and a relay shall enable the compressor to start under its controls.

When the space temperature drops to a value equal to the space temperature setpoint minus a differential, the liquid line solenoid valve shall close, and the compressor shall continue to operate until shut down by its low-pressure cutoff. Refrigerant system control and interlock wiring shall be as recommended by the compressor manufacturer.

FEATURES

1. The refrigerant liquid line solenoid valve is closed and the compressor cannot be energized when the supply fan is off.
2. Software time delays for compressor protection.

CONDITIONS FOR SUCCESSFUL OPERATION

The differential timers are set wide enough and the software timers are set high enough to prevent short cycling of the compressor under light load.

PSYCHROMETRIC ASPECTS

With on-off control, either cooled air or mixed air is supplied into the space.

In the following chart it is assumed that:

1. Desired space and RA condition is 22°C DB and 50% RH (18°C WB).
2. Design OA temperature is 35°C DB and 24°C WB.
3. Air entering the system is from the ECONOMIZER CYCLE DECISION application. The system operates on a minimum of 35 percent OA during the cooling cycle.
4. Coil leaving air temperature is 13°C.

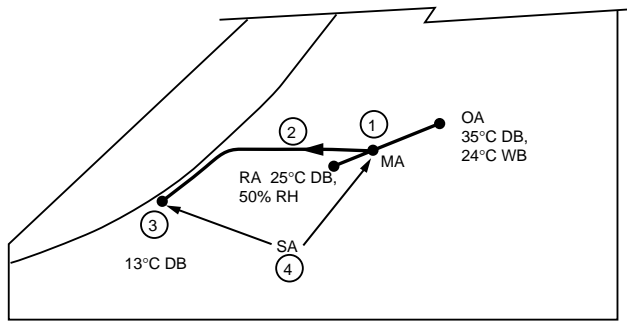

C3250

The following results are obtained:

Item No.	Explanation
1	Mixed air temperature at cooling design condition.
2	Air entering the coil is cooled along a line of constant moisture content until saturation is approached. Near saturation the moisture content is reduced as the air is cooled. This process involves both latent and sensible cooling.
3	When the space thermostat has the DX cooling energized, coil leaving air is at this value.
4	Air supplied to the space will alternate between Point 1 and Point 3 as determined by the space thermostat.

TWO-POSITION CONTROL OF DIRECT EXPANSION COIL SYSTEM—MODULATING FACE DAMPER AND BYPASS DAMPER

Functional Description

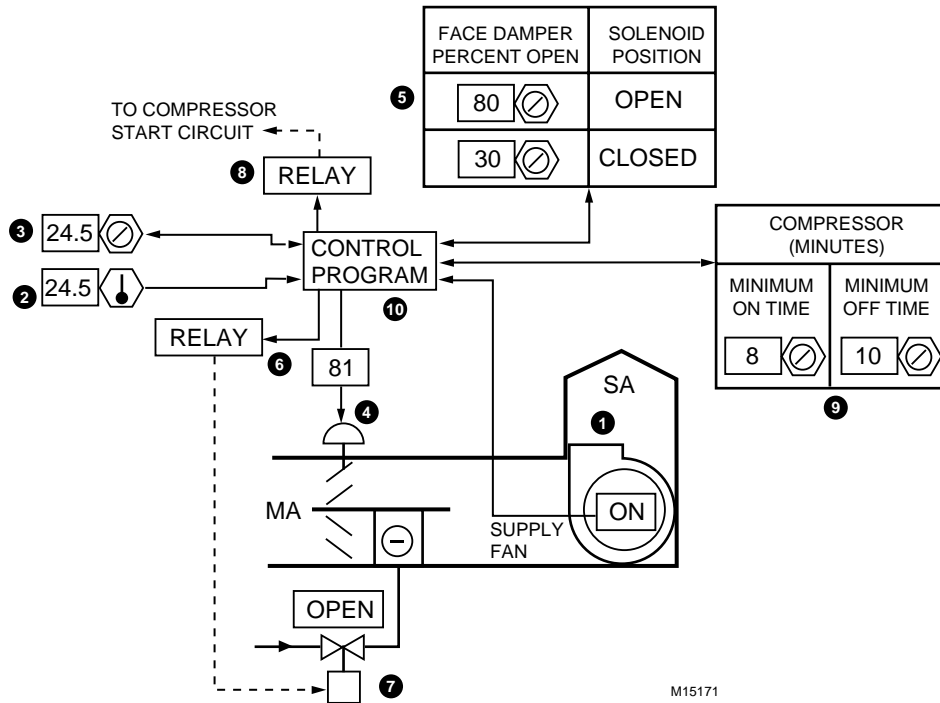

M15171

Item No.	Function
1	Control system energizes when fan is turned on (See FAN SYSTEM START-STOP CONTROL).
2,3	Space temperature sensor inputs to PID control loop to maintain setpoint.
4	Face and bypass damper modulates for cooling control.
5	Damper position determines compressor mode.
6,7	Refrigerant liquid line solenoid valve cycles for cooling.
8	Relay energizes compressor.
9	Timers protect compressor from short cycling.
10	Control program coordinates temperature, compressor, and fan interlock control.

FEATURES

1. The proportions of air passing through and around the coil are varied by modulating face and bypass dampers.
2. Lowering air velocity through the coil lowers the moisture content of air leaving the coil, thus producing lower space RH than systems that only cycle the refrigeration at a constant air volume.

CONDITIONS FOR SUCCESSFUL OPERATION

1. Capacity control of refrigeration provided to avoid icing under light load.

LIMITATIONS

1. Direct expansion coils are difficult to control from SA due to the large and rapid temperature drop when energized.
2. Compressor operating and safety controls must be incorporated into the control system.
3. The system may be controlled from SA if necessary, but only if the sensor is located far enough downstream of the coil to ensure complete mixing of the air and software timers are provided to prevent compressor short cycling. Hot gas bypass may be required.

SPECIFICATIONS

See FAN SYSTEM START-STOP CONTROL.

The DX control system shall be enabled anytime the fan operates.

Space temperature PI control loop shall modulate DX coil face and bypass dampers to maintain setpoint.

Anytime the face damper modulates up to 80% open, the refrigerant valve shall open and a relay shall enable the compressor to start under compressor controls. When the compressor system is commanded on, it shall remain on at least eight minutes and when it is commanded off (or drops off during power interruptions) it shall remain off at least ten minutes.

Anytime the face damper modulates down to 30% open, the refrigerant valve shall close and the compressor relay shall open.

When the solenoid valve is closed, the compressor shall continue to operate until shut down by its low-pressure cutout.

PSYCHROMETRIC ASPECTS

Cooled air from the coil is mixed with bypass air to provide the necessary DA temperature.

In the following chart it is assumed that:

1. Desired RA condition is 27°C DB and 50% RH (19.5°C WB).
2. Design OA condition is 35°C DB and 24°C WB.
3. Air entering the system is from the ECONOMIZER CYCLE DECISION application. The system operates on 25 percent OA during the cooling cycle.
4. Coil leaving air temperature is 13°C.

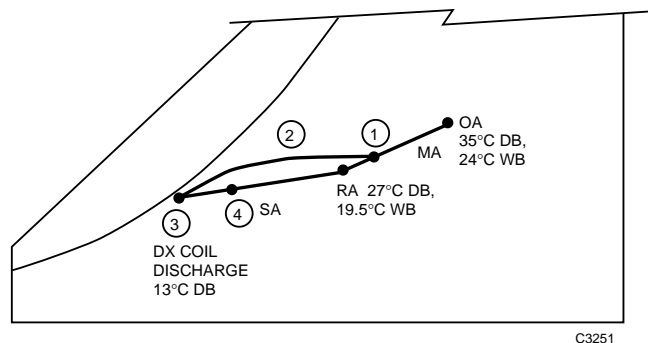

The following results are obtained:

Item No.	Explanation
1	Mixed air temperature at cooling design enters the cooling system.
2	Air enters the coil and is cooled along a line of constant moisture content until saturation is approached. Near saturation the moisture content is reduced as the air is cooled. This process involves both latent and sensible cooling.
3	When the space thermostat calls for DX cooling to be energized and the face damper greater is than 30% open, air leaving the DX coil is at this value.
4	Supply air will vary between Point 3 and Point 1 as the space thermostat positions the face and bypass dampers.

COLD DECK SYSTEM WITH ZONE DAMPER CONTROL

Functional Description

AS THE DEMAND FOR COOLING FROM THE ZONE VARIES BETWEEN ZERO AND 50%, ITS COLD DECK DAMPERS MODULATE BETWEEN CLOSED AND OPEN.

AS THE DEMAND FOR COOLING FROM THE ZONE WITH THE GREATEST DEMAND FOR COOLING VARIES BETWEEN 50% AND 100%, THE COLD DECK TEMPERATURE SETPOINT VARIES BETWEEN THE MIXED AIR TEMPERATURE AND 13 DEGREES.

9

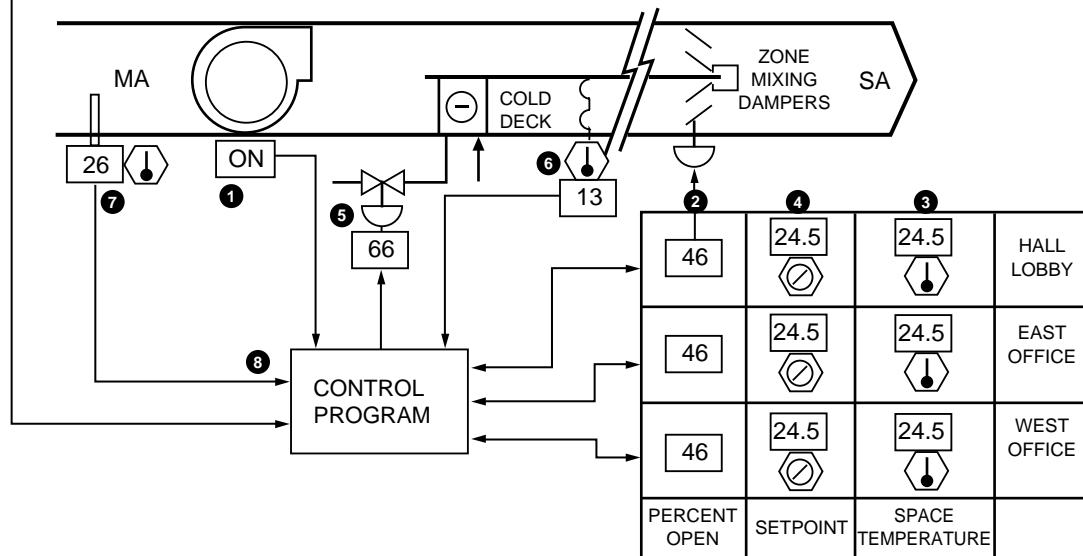

M15172

Item No.

Function

- 1 Control system energizes when fan is turned on (See FAN SYSTEM START-STOP CONTROL).
- 2-4 Zone mixing dampers modulate to maintain space temperature setpoint.
- 5,6 Chilled water valve modulates to maintain cold deck temperature setpoint.
- 7 Mixed air temperature determines cold deck temperature setpoint at zero cooling load.
- 8 Control program coordinates zone demand, temperature, and fan interlock control.
- 9 Dynamic graphic sequence display permits the operator to adjust program setpoints.

FEATURES

1. A mixing damper and temperature sensor for each zone provides individual zone control. (Three zones shown).
2. A single cooling coil or group of coils furnishes cooling for the entire system.
3. A constant volume of air is delivered to each zone.
4. Cold deck temperature is maintained just low enough to satisfy the zone requiring the greatest amount of cooling which provides efficient operation when used in conjunction with a hot deck coil/control multizone system.

CONDITIONS FOR SUCCESSFUL OPERATION

1. All zones are connected to load analyzer program to satisfy total load requirements. In larger systems only selected diverse zone loads are connected. Zones that may be allowed to go out of control (storage rooms, etc.) should not be connected to the load analyzer program.
2. Each zone duct has a balancing damper following the mixing dampers to ensure design volume to each zone.

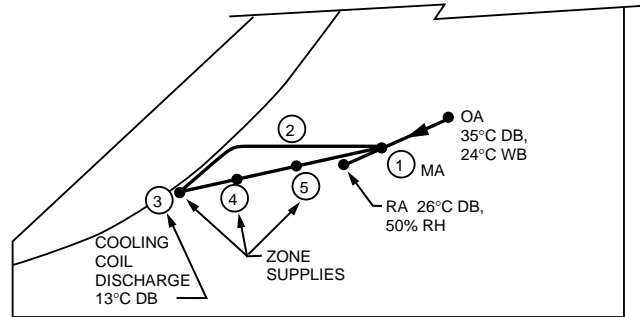

C3252

SPECIFICATIONS

See FAN SYSTEM START-STOP CONTROL.

Anytime the supply fan runs, cooling control shall be enabled.

Each zone cold deck mixing damper shall be modulated to maintain zone space temperature setpoint.

The chilled water valve shall be modulated to maintain the cold deck temperature setpoint.

Zone mixing dampers shall modulate from 0 to 100% open to the cold deck as their respective zone demands for cooling vary from zero to 50%.

The cold deck temperature setpoint shall be reset from the mixed air temperature to 13°C as the cooling demand from the zone with the greatest cooling demand varies from 50 to 100%.

PSYCHROMETRIC ASPECTS

In the following chart it is assumed that:

1. RA condition is 26°C DB and 50% RH (18.5°C WB).
2. Design OA condition is 35°C DB and 24°C WB.
3. Air entering the system is from the ECONOMIZER CYCLE DECISION application. The system operates on 35 percent OA during the cooling cycle.
4. One zone is calling for full cooling.
5. Other zones require partial cooling.
6. Coil leaving air temperature is 13°C.

The following results are obtained:

Item No.	Explanation
1	Mixed air temperature at cooling design condition.
2	Air entering the coil is cooled along a line of constant moisture content until saturation is approached. Near saturation the moisture content is reduced as the air is cooled. This process involves both latent and sensible cooling.
3	This condition represents the air leaving the cold deck and air supplied to the zone calling for full cooling.
4	This condition represents the SA to a zone with partial call for cooling. Both cooling and bypass dampers are partially open.
5	This condition represents the SA to a zone with a partial call for cooling but less than that at Point 4.

DEHUMIDIFICATION CONTROL PROCESSES

The following applications show various methods of controlling dehumidification in air conditioning systems.

DIRECT EXPANSION OR WATER COIL SYSTEM CONTROL

Functional Description

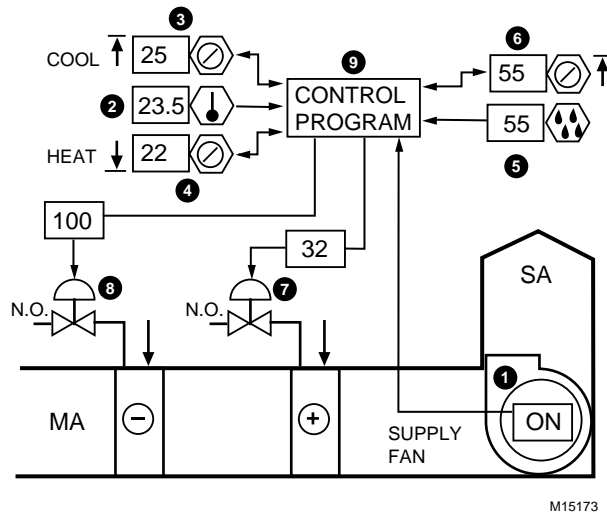

Item No.	Function
1	Control system energizes when fan is turned on (See FAN SYSTEM START-STOP CONTROL).
2-4	Space temperature PI control loops have heat and cool setpoints with deadband.
5,6	Space humidity sensor and setpoint enable dehumidification.
7,8	Heating and cooling valves position for heat, cool, and dehumidify cycles. The valves close when the fan is off.
9	Control program coordinates cooling, heating, dehumidifying, and fan and hot water interlock control.

FEATURES

1. This application uses two-position control of a direct expansion or chilled water coil for dehumidification.
2. This application controls both space temperature (with a dead band) and dehumidification.
3. Dehumidification cycle is disabled if hot water flow is not available.
4. Heating setpoint raised slightly during dehumidification cycle to reduce cooling (dehumidifying) energy.

CONDITIONS FOR SUCCESSFUL OPERATION

1. If a chilled water coil is used, the water supply is cold enough to produce the lowest required dew point.
2. The cooling coil valve should be two-position controlled for the dehumidification cycle for quick and maximum dehumidification. A space RH differential is required for two-position control, such as dehumidification on a rise to 60% RH and off on a drop to 55% RH. Modulating dehumidification control of a chilled water valve, which delays moisture removal until the chilled water flow gets high enough to cause condensation, is also satisfactory.
3. Hot water flow is available for reheat or the space will get very cold and humid during periods when dehumidification is demanded and the cooling load is light.

SPECIFICATIONS

See FAN SYSTEM START-STOP CONTROL.

1. Anytime the supply fan runs, control system shall be enabled.
2. The chilled water valve and hot water valve shall be modulated as required to maintain their separate heating and cooling space temperature setpoints.
3. Anytime the space relative humidity rises above its setpoint, the cooling valve shall position full open for maximum dehumidification. In this mode, the heating space temperature setpoint shall be midpoint between the heating and cooling setpoints, and the hot water valve shall be modulated to prevent the dehumidification cycle from overcooling the space.
4. The dehumidification cycle shall be disabled anytime there is no hot water flow or temperature.

PSYCHROMETRIC ASPECTS

In comfort air conditioning, dehumidification is typically required when the OA is cool and moist and the solar load is too low to demand enough cooling for dehumidification. The space relative humidity is maintained at or below a desired value, depending on the moisture content of the air entering the cooling coil.

AIR HANDLING SYSTEM CONTROL APPLICATIONS

In the following chart it is assumed that:

1. Desired space condition is 24°C DB and a maximum of 50% RH.
2. OA condition is 27°C DB and 26°C WB.
3. Air entering the system is from the ECONOMIZER CYCLE DECISION application. The system operates on 25 percent OA during the cooling cycle.
4. Cooling coil leaving air temperature is 13°C.

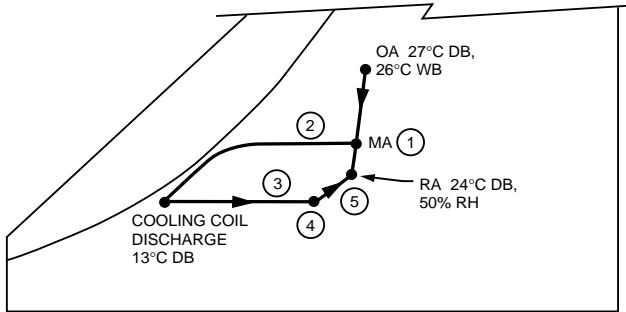

C3253

The following results are obtained:

Item No.	Explanation
1	Mixed air temperature at cooling design condition.
2	Air entering the cooling coil is cooled along a line of constant moisture content until saturation is approached. Near saturation the moisture content is reduced as the air is cooled. This process involves both latent and sensible cooling.
3	The final leaving air temperature necessary to satisfy space requirements will be maintained by reheating along a constant moisture line.
4	Heating coil discharge.
5	This process line represents the increase in temperature and humidity that occurs due to the sensible and latent heat gains in the space.

WATER COIL FACE AND BYPASS SYSTEM CONTROL

Functional Description

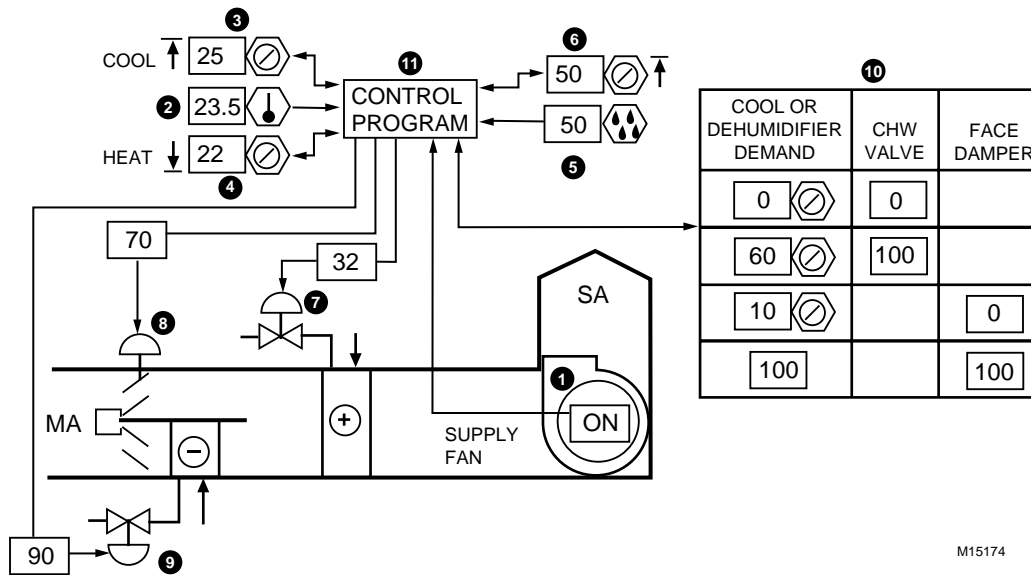

M15174

Item No.	Function		
1	Control system energizes when fan is turned on (See FAN SYSTEM START-STOP CONTROL).	7-9	Heating and cooling valves and face and bypass dampers position for heating, cooling, and dehumidifying cycles.
2-4	Space temperature PI control loops have heat and cool setpoints with deadband.	10	Stages chilled water and face-and-bypass damper loading.
5,6	Space humidity sensor and setpoint enable dehumidification.	11	Control program coordinates cooling, heating, dehumidifying, and fan and hot water interlock control.

FEATURES

1. Better dehumidification by having the chilled water flow sequence slightly ahead of the face damper opening to keep a low dew point temperature.
2. This application controls heating, cooling (with a dead band), and dehumidification.

CONDITIONS FOR SUCCESSFUL OPERATION

1. If a chilled water coil is used, the water supply is cold enough to produce the lowest required dew point.
2. To prevent frosting the coil under light load, if direct expansion coil is used, proper valve cut-in, staging, and cut-out settings related to the face and bypass damper position are determined.
3. Hot water flow is available for reheat or the space will get very cold and humid during periods when dehumidification is demanded and the cooling load is light.
4. During some chilled water coil loadings, the coil leaving water temperature may drop quite low. If this is undesirable to the chiller plant, a coil leaving air temperature low limit PID loop will reduce the effects.
5. If a DX coil is used, the liquid line solenoid valve is staged with the damper position and software timers are provided to prevent frosting the coil and to prevent short cycling the refrigeration system.

NOTE: The balance of this discussion is for a chilled water coil system.

SPECIFICATIONS

See FAN SYSTEM START-STOP CONTROL.

Anytime the supply fan runs, the control system shall be enabled.

The hot water valve shall be modulated as required to maintain the heating space temperature setpoint. Anytime the chilled water valve is full open, because of a demand for dehumidification, the actual heating space temperature setpoint shall be midpoint between the heating and cooling setpoints.

As the space temperature cooling PI loop or the space humidity high limit PI loop demand (whichever demand is greater) for cooling varies from 0 to 60 percent, the chilled water valve shall position from closed to open. As the space temperature or the humidity PI loop demand (whichever demand is greater) for cooling varies from 10 to 100 percent demand the face and bypass dampers shall position from closed to open to the coil face.

The dehumidification cycle shall be disabled anytime the hot water pump is off or the hot water temperature is inadequate.

PSYCHROMETRIC ASPECTS

The space relative humidity is maintained at or below a desired value depending on the moisture content of the air entering the coil.

In the following chart it is assumed that:

1. Chilled water (not DX) is used
2. Desired space condition is 27°C DB and 50% RH.
3. Outdoor air condition is 27°C DB and 24°C WB.
4. Air entering the system is from the MIXED AIR CONTROL WITH ECONOMIZER CYCLE application. The system operates on 25 percent outdoor air during the cooling cycle.
5. Cooling coil leaving air temperature is 13°C.

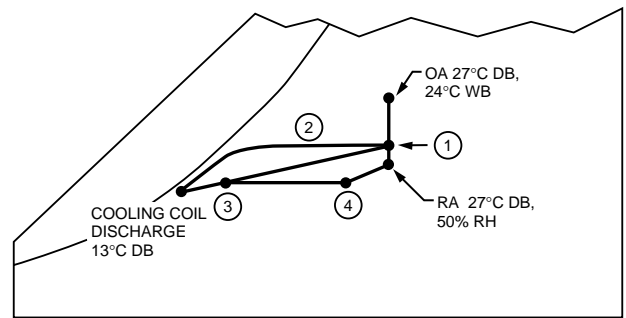

C3254

The following results are obtained:

Item No.	Explanation
1	Mixed air temperature.
2	Air entering the cooling coil is cooled along a line of constant moisture content until saturation is approached. Near saturation the moisture content is reduced as the air is cooled. This process involves both latent and sensible cooling.
3	This point represents air entering the heating coil which is a mixture of cooling coil leaving air through the face damper and the mixed air through the bypass damper. If the cooling or dehumidification load decreases, air entering the heating coil will move toward the mixed air condition. If the cooling or dehumidification load increases, air entering the heating coil will move toward the cooling coil leaving air condition.
4	As the cooling sensible load decreases, the heating coil valve will open and Point 4 moves on a constant moisture line from Point 3.

HEATING SYSTEM CONTROL PROCESS

SPACE CONTROL OF HEATING, ECONOMIZER (FREE COOLING), AND HUMIDIFICATION

Functional Description

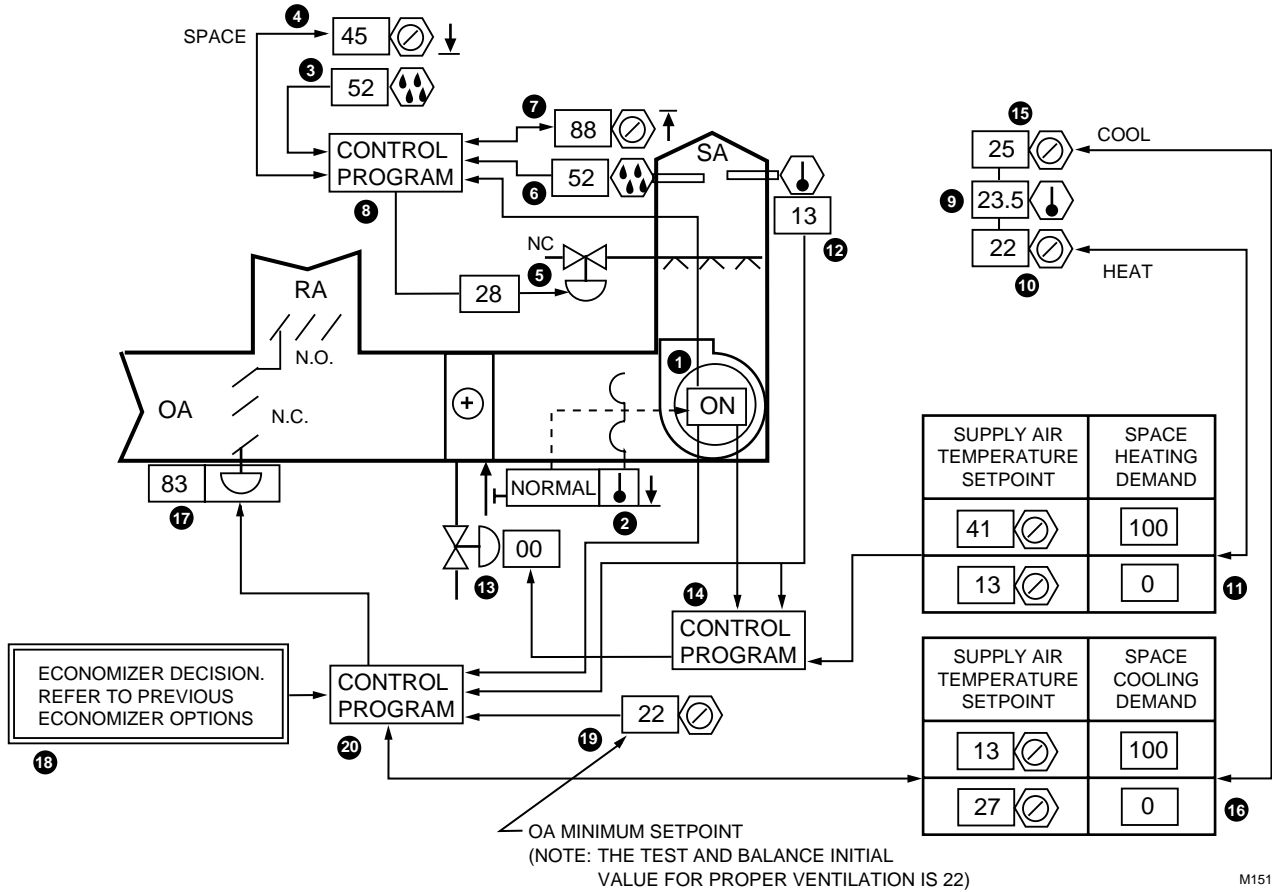

M15175

Item No.

Function

1,2	Control system energizes when fan is turned on (See FAN SYSTEM START-STOP CONTROL).	13	Hot water valve modulates to maintain SA temperature setpoint.
3-5	Space humidity PI loop controls humidifier valve if space humidity falls to setpoint.	14	Control program coordinates space and SA heating control and fan interlock.
6,7	SA humidity high limit PI loop throttles humidifier valve if duct humidity rises above setpoint.	15,16	Space temperature cooling PI loop inputs to SA temperature cooling reset schedule.
8	Control program coordinates space and humidifier leaving air humidity control and fan interlock.	17	Mixing dampers modulate to maintain SA temperature setpoint.
9-11	Space temperature heating PI loop inputs to SA temperature heating reset schedule.	18	Economizer decision program determines when OA is suitable to assist with cooling demand.
12	SA temperature PI loop inputs to heating and mixed air control programs.	19	Mixing dampers minimum ventilation value.
		20	Control program coordinates space and supply cooling control, ventilation control, and fan interlock.

FEATURES

1. The outdoor air quantity is modulated from a minimum to take advantage of free cooling based on space temperature demand.
2. The SA temperature will not fall below a set minimum.
3. Air is supplied at the temperature necessary to make up the sensible heat loss of the space.
4. Space relative humidity is maintained at a minimum value by a space humidity controller controlling the humidifier.
5. Separate setpoints for heating and cooling.

CONDITIONS FOR SUCCESSFUL OPERATION

See FAN SYSTEM START-STOP CONTROL.

1. An appropriate schedule of settings.
2. The low temperature limit controller located to respond to the lowest temperature in the duct.

LIMITATIONS

This application used in applications that do not require mechanical cooling.

SPECIFICATIONS

Anytime the supply fan runs, control system shall be enabled.

Anytime the space relative humidity drops below the setpoint, the space humidity PI loop shall modulate the humidifier, subject to an SA humidity high limit override set at 88%.

As the space heating load varies from 0 to 100%, the SA heating PID loop setpoint shall be reset from 13°C to 41°C. The hot water valve shall be modulated as required to maintain the SA temperature setpoint.

Anytime the fan runs, the mixing dampers shall position to a minimum ventilation setting.

As the space cooling load varies from 0 to 100%, the SA cooling PI loop setpoint shall be reset from 27°C to 13°C. The outdoor and return (and relief if applicable) air dampers shall be modulated as required to maintain the SA temperature setpoint.

Cooling damper control shall be returned to minimum position anytime the economizer mode is disabled.

Separate space heating and cooling setpoints shall be provided.

PSYCHROMETRIC ASPECTS

In the following charts it is assumed that:

1. Design outdoor air condition is -18°C DB and 50 percent relative humidity.

2. SA condition at design load is 32°C DB and 7.0 grams of moisture per kilogram of dry air.
3. Light load outdoor air condition is 13°C DB and 11.5°C WB.
4. SA condition at light load is 24°C DB and 7.0 grams of moisture per kilogram of dry air.
5. Minimum outdoor air is 25 percent.
6. RA condition is 23.5°C DB and 35% RH.

Design Load

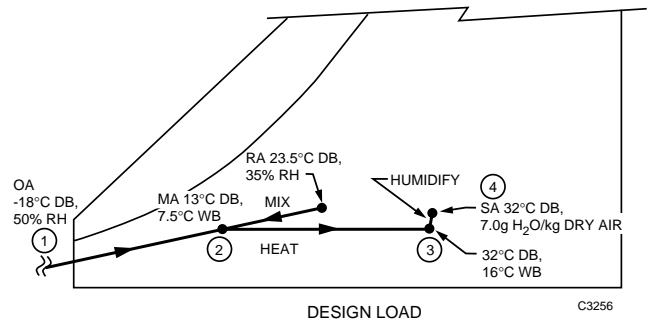

The following results are obtained:

Item No.	Explanation
1	Design outdoor air condition is -18°C DB and 50 percent relative humidity.
2	Mixed air condition is 12.5°C DB and 7.5°C WB.
3	Heated air condition is 32°C DB and 16°C WB.
4	SA condition is 32°C DB and 7.0 grams of moisture per kilogram of dry air.

Light Sensible Load

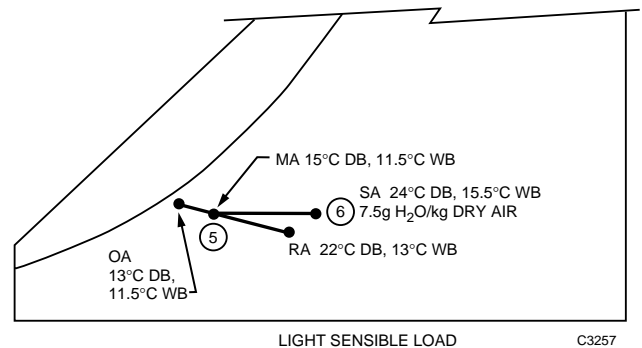

The following results are obtained:

Item No.	Explanation
5	Mixed air condition is 15°C DB and 11.5°C WB.
6	SA condition is 24°C DB, and 7.5 grams of moisture per kilogram of dry air.

YEAR-ROUND SYSTEM CONTROL PROCESSES

HEATING, COOLING, AND ECONOMIZER

Functional Description

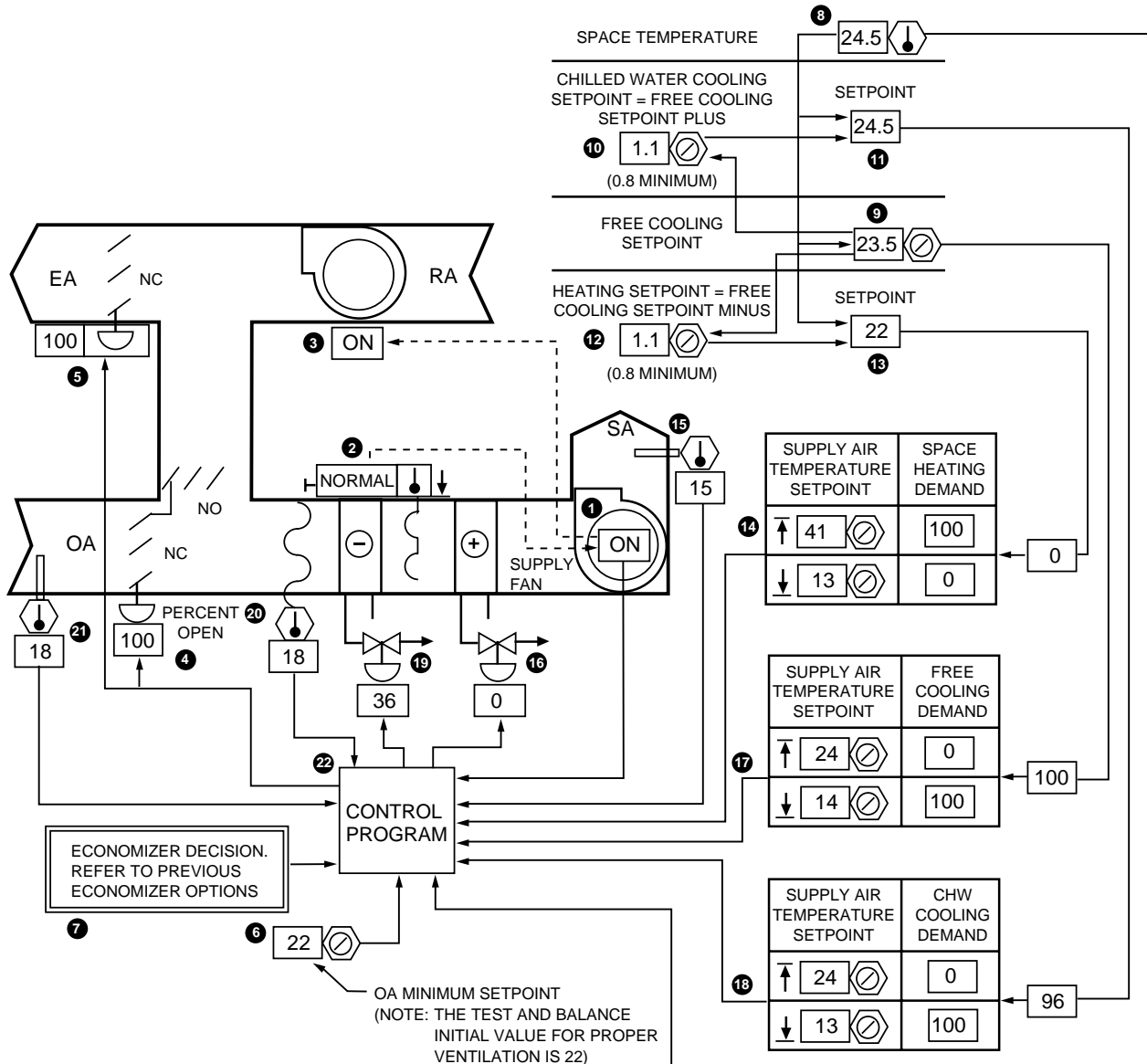

M15176

Item No.

Function

- | | | | |
|-----|---|------|--|
| 1-3 | Control system energizes when fan is turned on (See FAN SYSTEM START-STOP CONTROL). | 8 | Space temperature dictates heat and cool demands. |
| 4-6 | Mixing dampers modulate to maintain minimum ventilation value and free cooling SA temperature setpoint. | 9-13 | Free cooling setpoint and heat/cool dead-band values determine the SA temperature setpoint for hot and chilled water control setpoints. Software has a minimum 0.8 kelvins heating and cooling deadband. |
| 7 | Economizer enables free cooling when OA is appropriate. | 14 | Heat demand varies SA temperature setpoint. |

- 15,16 Hot water valve modulates to maintain SA temperature setpoint.
- 17 Free cooling demand varies SA temperature setpoint.
- 18 Chilled water cooling demand varies SA temperature setpoint.
- 19 Chilled water valve modulates to maintain SA temperature cooling setpoint.
- 20 MA temperature sensor for operator information.
- 21 OA temperature sensor for operator information.
- 22 Control program coordinates space and supply cooling, heating, and ventilation control, and fan interlock.

FEATURES

1. Use of space control resetting SA temperature control adds stability. The MA sensor is required to prevent freeze-up if the free cooling setpoint is lowered in freezing weather.
2. SA temperature is maintained only as high or low as required to meet space requirements.
3. Free cooling cycle selection determined by the economizer control program to minimize load on mechanical cooling system.
4. Optimum comfort temperature provided during free cooling cycle with energy conserving deadbands for heating and cooling.

CONDITIONS FOR SUCCESSFUL OPERATION

1. Sensor locations must be selected to measure representative air conditions.
2. SA temperature control loops should provide PI control to assure stability with minimum offset.

NOTE: In cold climates this unit would most often have the heating coil ahead of the cooling coil and the low temperature switch after the heating coil. Control would not change. In the configuration shown, it would be possible to add a dehumidification cycle with reheat (software) at a later time.

SPECIFICATIONS

See FAN SYSTEM START-STOP CONTROL.

Anytime the supply fan runs, control system shall be enabled, and mixing dampers shall position to minimum ventilation position during scheduled occupancy periods.

Anytime the economizer decision program determines that OA is suitable to assist in cooling, the temperature controls shall be enabled to override the dampers minimum ventilation position for free cooling as required.

The space temperature shall have a free cooling PI loop setpoint selected to provide optimum occupant comfort temperature. The space temperature shall have a chilled water cooling PI loop setpoint adjustable to no lower than 0.8 kelvins (minimum) above the free cooling setpoint. The space temperature shall have a heating PI loop setpoint adjustable to no higher than 0.8 kelvins (minimum) below the free cooling setpoint.

As the space heating load varies from 100 to 0%, an SA heating PI control loop setpoint shall vary from 41°C to 13°C. The hot water valve shall modulate to maintain the heating SA temperature setpoint, except that anytime the space temperature is greater than one degree above the free cooling space temperature setpoint, the hot water valve control PI setpoint shall be 11°C.

As the space free cooling load varies from 0 to 100%, an SA free cooling PI control loop setpoint shall vary from 24°C to 14°C. The mixing dampers shall modulate to maintain the free cooling SA temperature setpoint.

As the space chilled water cooling load varies from 0 to 100%, an SA chilled water cooling PI control loop setpoint shall vary from 24°C to 13°C. The chilled water valve shall modulate to maintain this cooling SA temperature setpoint.

PSYCHROMETRIC ASPECTS

In the following chart it is assumed that:

1. OA condition is 18°C and 53% RH.
2. System is in the economizer mode.

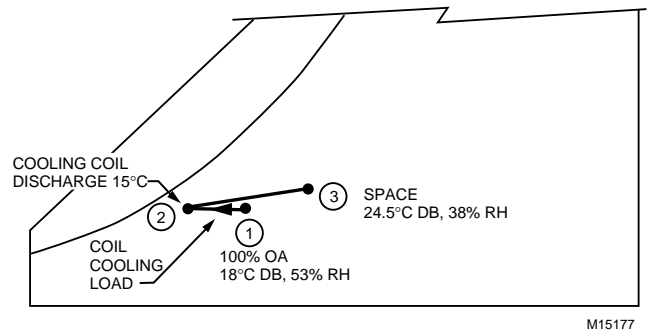

The following results are obtained:

Item No.	Explanation
1	100% economizer air is entering the cooling coil.
2	The chilled water coil cools the entering air to its 15°C setpoint (removing little moisture because the water flow is low and the OA moisture content is not high).
3	Space temperature is 24.5°C and 38% RH.

MULTIZONE UNIT

Functional Description

THE ZONE WITH THE GREATEST HEATING DEMAND RESETS THE HOT DECK TEMPERATURE FROM 13 TO 36 DEGREES AS REQUIRED TO MAINTAIN ITS SPACE TEMPERATURE 1.0 DEGREES BELOW SETPOINT.

THE ZONE WITH THE GREATEST COOLING DEMAND RESETS THE COLD DECK TEMPERATURE FROM 26 TO 15 DEGREES AS REQUIRED TO MAINTAIN ITS SPACE TEMPERATURE 1.0 DEGREES ABOVE SETPOINT.

6	5	7	
46	23.5	23.5	HALL LOBBY
62	23.5	23.5	EAST OFFICE
100	23.5	24.5	WEST OFFICE
PERCENT OPEN TO COLD DECK	SETPOINT	SPACE TEMPERATURE	

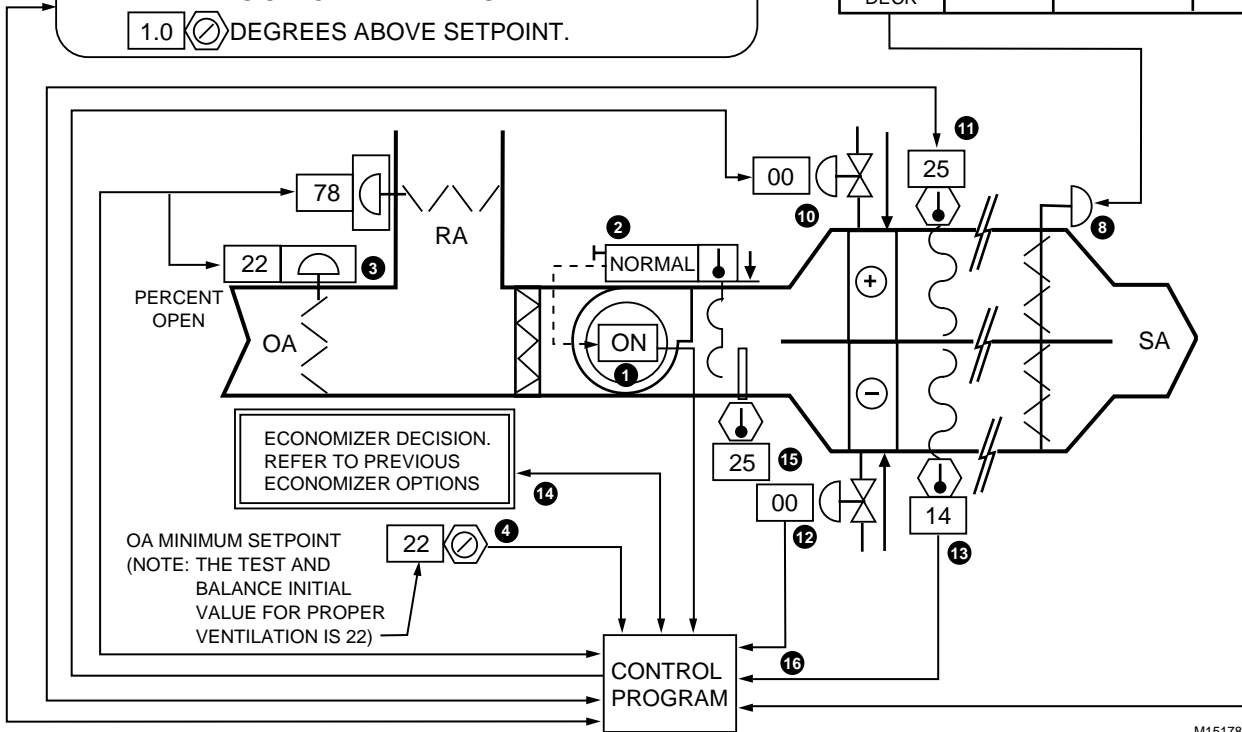

M15178

Item No.

Function

- | | | | |
|-----|--|-------|---|
| 1,2 | Control system energizes when fan is turned on (See FAN SYSTEM START-STOP CONTROL). | 10,11 | Hot deck valve modulated to maintain hot deck temperature setpoint. |
| 3,4 | Mixing dampers position to minimum position during occupied fan operation and modulate for cooling. | 12,13 | Cold deck valve modulated to maintain cold deck temperature setpoint. |
| 5-8 | Zone mixing dampers modulate to maintain space temperature setpoint. | 14 | Economizer enables free cooling when OA is suitable. |
| 9 | Zone with greatest cooling demand determines cold deck temperature setpoint, and zone with greatest heating demand determines hot deck temperature setpoint. | 15 | Fan leaving air temperature for operator information. |
| | | 16 | Control program coordinates cooling, heating, ventilation, and fan interlock control. |

FEATURES

1. This application uses zone control of heating and cooling.
2. Deck temperatures dictated by zones with greatest heating and cooling demand and with a deadband.

CONDITIONS FOR SUCCESSFUL OPERATION

All zones should be connected to load analyzer program to satisfy total load requirements. However, in larger systems it may be good practice to connect only selected diverse zone loads. Zones that may be allowed to go out of control (storage rooms, etc.) should not be connected to the load analyzer program.

SPECIFICATIONS

See FAN SYSTEM START-STOP CONTROL.

Anytime the supply fan runs, control system shall be enabled, and mixing dampers shall position to minimum ventilation position during scheduled occupancy periods.

Each zone space temperature PID loop shall modulate its zone mixing dampers to maintain its space temperature setpoint.

The zone with the greatest temperature deviation below setpoint shall reset the hot deck temperature setpoint from 13°C to 36°C as required to maintain the zone space temperature 2 degrees below setpoint.

The zone with the greatest temperature deviation above setpoint shall reset the cold deck temperature setpoint from 25.5°C to 13°C as required to maintain the zone space temperature 1 degree above setpoint.

The hot deck PID loop shall modulate the hot deck hot water valve to maintain the hot deck temperature setpoint.

The cold deck PID loop shall modulate the OA/RA mixing dampers in sequence with the cold deck chilled water valve to maintain the cold deck temperature setpoint.

Anytime the economizer decision program determines that OA is unsuitable to assist in cooling, the OA/RA mixing dampers shall be returned to their minimum ventilation position.

PSYCHROMETRIC ASPECTS

In the summer, zone space temperature is maintained by mixing air from the hot deck with cold deck air (the temperature of which is dictated by the zone with the greatest demand for cooling). The zone with the greatest demand for cooling gets 100% cold deck air.

In the winter, zone space temperature is maintained by mixing air from the cold deck with hot deck air (the temperature of which is dictated by the zone with the greatest demand for heating). The zone with the greatest demand for heating gets 100% hot deck air. The zone with the greatest demand for cooling (assuming a zone space temperature rises two degrees above setpoint and demands cooling) gets 100% cold deck air and dictates the cold deck temperature maintained via the economizer cycle.

In the following chart it is assumed that:

1. Desired space condition is 24°C DB.
2. Outdoor air condition is 24°C DB and 80% RH.
3. The mixed air is 25 percent outdoor air during the cooling cycle.
4. Coil leaving air temperature is 13°C (at least one zone demands full cooling).

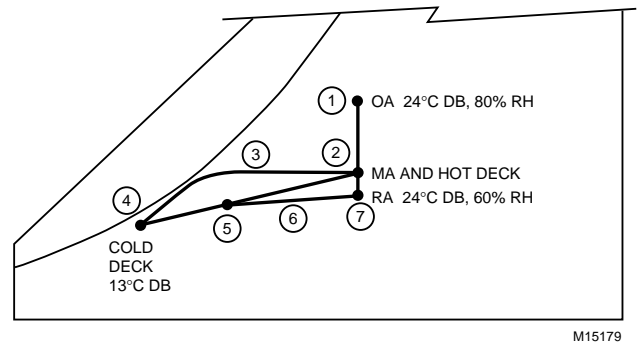

M15179

The following results are obtained:

Item No.	Explanation
1	OA temperature at example time.
2	Mixed air is 25% OA and 75% RA. This is also the hot deck air, assuming no zone temperature has dropped two degrees and demanded heating.
3	This line represents the cooling process of the cold deck air. The zone demanding the most cooling dictates how far the process goes from Point 2 to Point 4.
4	13°C DB is the minimum cold deck setpoint set up in the program, set by a zone requiring full cooling.
5	Discharge air to a zone requiring half cold deck air and half mixed air.
6	The space cooling process line.
7	Return air is 24°C DB and 60% RH (humidity rises because humidity is high outdoors and only partial supply airflow is dehumidified).

HEATING, COOLING, HUMIDIFICATION, AND DEHUMIDIFICATION CONTROL WITHOUT DEAD-BANDS

Functional Description

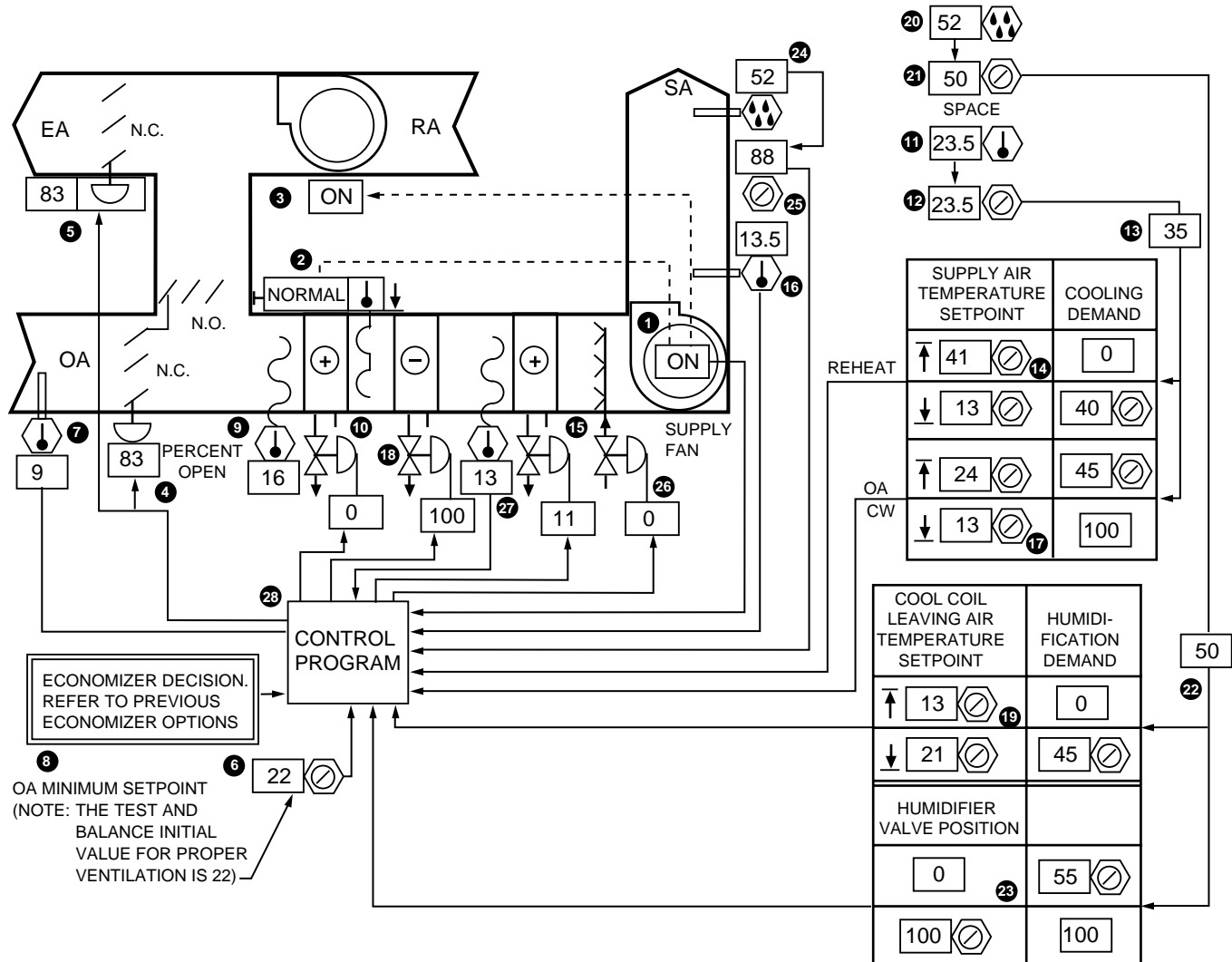

M15180

Item No.	Function		
1-3	Control system energizes when fan is turned on (See FAN SYSTEM START-STOP CONTROL).	17,18	Chilled water valve modulates in sequence with mixing dampers as required to maintain SA PI setpoint.
4-6	Manual positioning value determines minimum ventilation mixing damper position.	19	Chilled water coil leaving air temperature lowered if required for dehumidification.
7	Operator information, outdoor air temperature.	20-26	Space humidity PI control loop modulates humidifier valve to maintain space relative humidity, subject to an SA high limit humidity PI loop.
8	Economizer enables free cooling when OA is suitable.		
9	Operator information, MA temperature.		
10,27	Heating coil valve modulates to keep reheat coil entering air from getting too low.	27	Control program coordinates ventilation, heating, cooling, humidification, dehumidification, and fan interlocks.
11-16	Space temperature PI loop resets setpoint of reheat coil SA PI loop to maintain constant space temperature.		

FEATURES

1. The system admits outdoor air for cooling based upon the economizer decision.
2. Space relative humidity is maintained by controlling both humidification and dehumidification.
3. Reheat prevents subcooling on dehumidification cycle.
4. Constant temperature and humidity control. (Do not use this where deadband temperature or humidity control is acceptable.)

CONDITIONS FOR SUCCESSFUL OPERATION

1. Heating is available during dehumidification cycle.

SPECIFICATIONS

See FAN SYSTEM START-STOP CONTROL.

1. Anytime the supply fan runs, control system shall be enabled, and mixing dampers shall position to minimum ventilation position during scheduled occupancy periods.
2. Anytime the economizer decision program determines that OA is suitable to assist in cooling, the OA/RA mixing dampers shall be under control of the SA PI loop.
3. The space humidity PI loop shall modulate the humidifier, subject to a humidifier leaving air high limit humidity PI loop setpoint, to maintain the space humidity PI loop setpoint. Humidifying control shall be disabled anytime the chilled water valve is modulating or the fan is off.
4. The space humidity PI loop shall override the temperature controls to modulate the chilled water valve open for dehumidification if required to maintain the space humidity PI loop setpoint. The dehumidifying control loop shall be disabled anytime there is no hot water flow or temperature.
5. As the SA PI cooling demand varies from 100 to 45%, the cooling SA PI loop setpoint shall vary from 13°C to 24°C.
6. As the SA PI cooling demand varies from 40 to 0%, the reheat coil hot water valve SA PI loop setpoint (chilled water and economizer) shall vary from 11°C to 41°C.
7. The heating coil hot water valve shall modulate to prevent the cooling coil leaving air temperature from dropping below 11°C.

PSYCHROMETRIC ASPECTS

For cooling conditions it is assumed that:

1. Design outdoor air condition is 35°C DB and 26°C WB.
2. RA condition is 24.5°C DB and 18°C WB.
3. System operates on 25 percent minimum outdoor air.
4. Space temperature setpoint is set at 23.5.
5. Space humidity control is set at 50 percent.
6. Coil leaving air temperature is at 13°C.

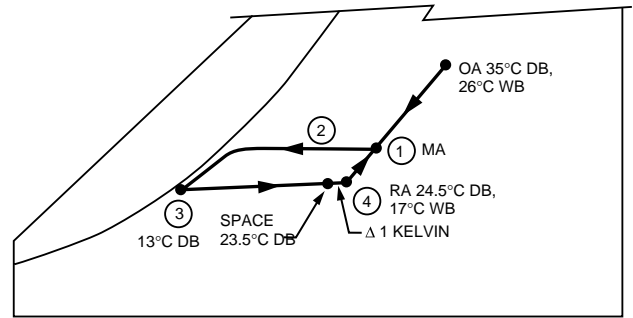

COOLING

C3263

The following results are obtained:

Item No.	Explanation
1	Mixed air temperature at cooling design condition.
2	Air entering the coil is cooled along a line of constant moisture content until saturation is approached. Near saturation the moisture content is reduced as the air is cooled. This process involves both latent and sensible cooling.
3	Cooling coil leaving air temperature will be as low as required to satisfy either the space temperature controller or the space humidity controller whichever is calling for the greatest cooling. If dehumidification cools discharge temperature below setpoint, the heating coil provides reheat.
4	The space temperature is 23.5°C DB and the RA temperature is 24.5°C DB. The 1 kelvin DB rise is an example of sensible cooling load which may occur in ceiling, space, and RA ducts. The rise will be a function of system, building, and lighting arrangement.

For heating conditions it is assumed that:

1. Design outdoor air condition is -18°C DB and 30 percent relative humidity.
2. RA condition is 24.5°C DB and 13.5°C WB.
3. System operates on 25 percent minimum outdoor air.
4. Space temperature is set at 23.5°C .
5. Space humidification control is set at 50 percent.

The following results are obtained:

Item No.	Explanation
1	Heating coil leaving air temperature will be as high as required to satisfy the space temperature controller.
2	Humidification will be provided to satisfy space humidification requirements.
3	The space heating and humidifying load varies with people and weather.
4	The 1 kelvin DB RA rise is discussed in the cooling example.

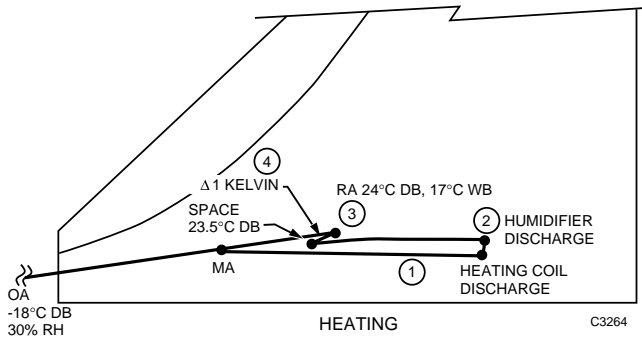

VAV AHU, WATER-SIDE ECONOMIZER, OA AIRFLOW CONTROL

Functional Description

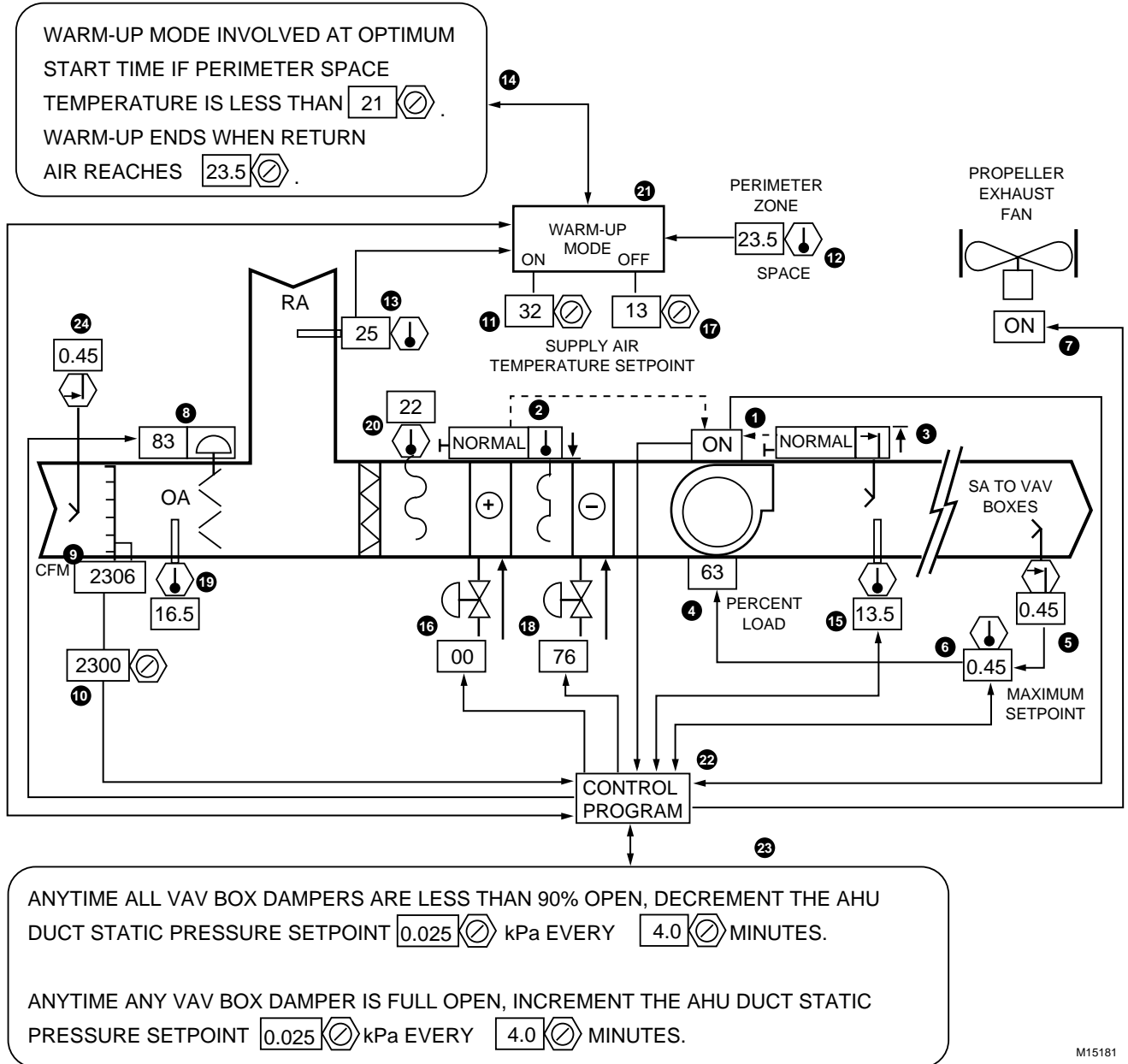

M15181

Item No.

Function

1-3	Control system energizes when supply fan is turned on (See FAN SYSTEM START-STOP CONTROL).	15-16	Heating valve maintains SA temperature setpoint during warmup.
4-6	Supply fan loads to maintain duct static pressure.	17-18	Cooling valve maintains SA temperature setpoint during occupied periods.
7-10	During occupied periods, exhaust fan runs and OA airflow is controlled.	19-20	OA and MA temperatures are operator information.
11-14	When perimeter temperature is low at startup, SA temperature setpoint is warm until RA temperature rises.	21	SA temperature setpoint switches from cooling to heating value during warm-up modes.
		22	Control program coordinates temperature control, ventilation, and fan interlock.

- 23 Control program optimizes duct pressure setpoint.
- 24 OA shaft static pressure point shared from OA fan control system for this graphic (not a physical point as shown) and provided here for operator information.

NOTE: This system is often found on each floor of a building, and often includes an outdoor air fan (preferably with filtration to protect the AHU OA air flow elements) and shaft, and a water-side economizer. The water-side economizer provides chilled water year round (in cold weather the cooling tower provides chilled water via heat exchangers without the need for the chillers). Dual equal sized chillers and boilers (non-redundant) are assumed.

FEATURES

1. Supplies constant temperature variable volume (energy conserving) air to VAV boxes.
2. Provides constant airflow of OA with varying supply airflow.
3. Provides 100% RA during warm-up periods (preoccupancy purge may be required for IAQ).
4. Perimeter boxes provide space heat when required during occupied periods.
5. AHU provides heating during warm-up periods, and when OA temperature effects cause low SA temperatures. If boxes have electric heat and the AHU hot water is from lower cost gas/oil-sourced heat, box heaters may be disabled during warm-up periods.
6. Duct static pressure setpoint is lowered anytime all VAV box dampers are less than 90% open (If this strategy is used, the duct static pressure pickup need not be at the end of the longest run, but may be at any location where the air is not too turbulent. The maximum setpoint is higher than if the pickup had been at the end of the run because of the pickup location).
7. Reduced fan airflow is provided during warmup, night purge, and cool-down periods to reduce fan energy, which varies with the cube of the fan airflow.
8. Reduced fan airflow and staged AHU startup during cool-down periods requires only one chiller and keeps the chiller pull-down ahead of the AHU cooling demands such that AHUs get cold (not cool) water for effective cooling and dehumidification, and allows the chiller to operate at an efficient loading (less than 100%).

CONDITIONS FOR SUCCESSFUL OPERATION

1. Airflow element and transducer must be kept clean and calibrated.
2. OA fan must provide adequate OA shaft pressure. Alternatively, if there is no OA fan, the OA airflow setpoint may be maintained by modulating the RA damper which would have to be added.
3. A controller network and adequate software and programming provided to support communication between the box controllers and the fan controller to allow static pressure reset and to position the box dampers properly during night purge, warmup, and cool-down periods.
4. If any VAV box whose damper position is a program input can never satisfy its space cooling demand for any reason (and its damper is always open), the duct static pressure reset program will not lower the duct static pressure setpoint. The duct static pressure reset program works best when there are no more than thirty monitored VAV boxes per fan system (with great quantities of boxes, it is likely that at least one box damper will always be full open). For example, if an interior zone is always under a full cooling load, static pressure reset will not occur unless that zone (and similar zones) is oversized. The oversized zone would then throttle back when the building is at full load when the duct static pressure is at design.
5. All AHUs must be near the same normal occupancy schedule or the cool-down start-up specification edited.
6. Boiler, chiller, pumping system, and OA fan controls carefully networked into the AHU control schemes to assure smooth and efficient building operations.
7. All specified values and setpoints are tuned to specific project requirements.

SPECIFICATIONS

NOTE: A set of 16 similar sized AHUs are assumed.

See FAN SYSTEM START-STOP CONTROL.

Anytime any AHU starts in the optimum start cool-down mode, three to four AHUs shall start and the remaining AHUs shall stage on at five minute intervals (unless they similarly start under their optimum start programs). Any time any AHU operates in the night purge, warmup, or cool-down modes of operation, all associated perimeter VAV boxes shall operate at 60% of their maximum airflow setpoint, and all associated interior VAV boxes shall operate at 25% of their maximum airflow setpoint, unless the OA temperature is less than -9.5°C in which case the perimeter VAV boxes shall operate at their maximum airflow setpoint.

During unoccupied periods, anytime the top floor west zone perimeter space temperature is greater than 25°C and the OA temperature is less than 22°C and the OA dew point is less than 16°C, the night purge program shall start. When the night purge program starts, AHUs 9 through 16 (provided their west zone space temperatures are greater than 23.5°C) shall start, and the OA and exhaust fans shall start. When an AHU runs in the night purge mode, its OA damper shall position full open. When the OA fan runs in the night purge mode, its duct static pressure setpoint shall be reset to a value 50% above the normal maximum setpoint. AHU fans running in the night purge mode shall stop when their noted space temperature drops to 23.5°C.

Anytime the night purge program runs for one minute and any of AHUs 9 through 16 are off, AHU's 8 through 1 shall start respectively on a one-for-one basis (provided their west zone space temperatures are greater than 23.5°C). Anytime all fans shut down in the night purge mode, the night purge program mode shall end.

Anytime the supply fan runs, the return fan shall start and the control system shall be enabled. Also, anytime the supply fan runs during scheduled occupancy periods the exhaust fan shall start.

At the scheduled occupancy time, each AHU OA damper control loop shall be enabled under EPID control with a start value of 50 and a ramp duration of 400 seconds. Each AHU OA damper shall modulate to maintain its OA airflow setpoint.

The supply fan loading shall be under EPID control with a start value of 20% and ramp duration of 150 seconds. The supply fan shall load to maintain the duct static pressure setpoint.

The SA temperature shall be under EPID control with a start value of 50% (at which point the hot and chilled water valves are both closed) and a ramp duration of 120 seconds. The hot and chilled water valves shall be modulated in sequence to maintain the SA temperature setpoint.

Anytime the optimum start perimeter zone space temperature sensor is less than 21°C at start-up time, the SA temperature setpoint shall be 32°C until the RA temperature rises to 23°C, at which time the SA temperature setpoint shall be lowered to 13°C. The EPID shall be invoked at the switching of the setpoint to 13°C with a start value of 50 and a ramp duration of 180 seconds.

EXPLANATION:

With VAV fan systems, operation during unoccupied periods should be based on minimum energy cost (not minimum on-time). Ideally, for a dual chiller building, the VAV box airflow would be regulated to run one chiller at its most efficient

operating point. At this point the AHU fan would draw a small portion of its full-load amperage, good dehumidification would occur, and pumping energy may be reduced. In the night purge mode of operation, the objective is to supply a maximum amount of OA to the AHUs, and to direct it to the warm areas of the building. Reducing the AHU airflow and increasing the OA airflow should result in the supply airflow being a significant proportion OA. If IAQ requirements dictate a prepurge cycle, this operational mode should suffice then also, but would be staged by time rather than temperature.

PSYCHROMETRIC ASPECTS

In the following chart it is assumed that:

1. Outdoor air condition is 35°C DB and 26°C WB.
2. RA condition is 25.5°C DB and 14.5°C WB.
3. Coil leaving air temperature 10°C.
4. 80% RA.

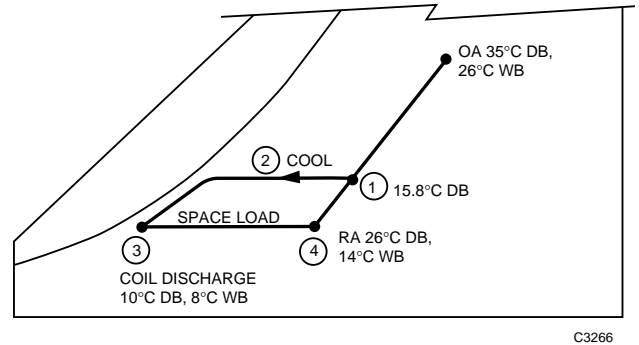

The following results are obtained:

Item No.	Explanation
1	RA mixes with 20 percent (minimum position) outdoor air to obtain mixed air condition.
2	Air entering the coil is cooled along a line of constant moisture content until saturation is approached. Near saturation the moisture content is reduced as the air is cooled. This process involves both latent and sensible cooling.
3	Mixed air is cooled and dehumidified by cooling coil to obtain cooling coil leaving air condition.
4	Reheat coils and/or space internal load heats air to 25.5°C DB and 14.5°C WB.

VAV AHU WITH RETURN FAN AND FLOW TRACKING CONTROL

Functional Description

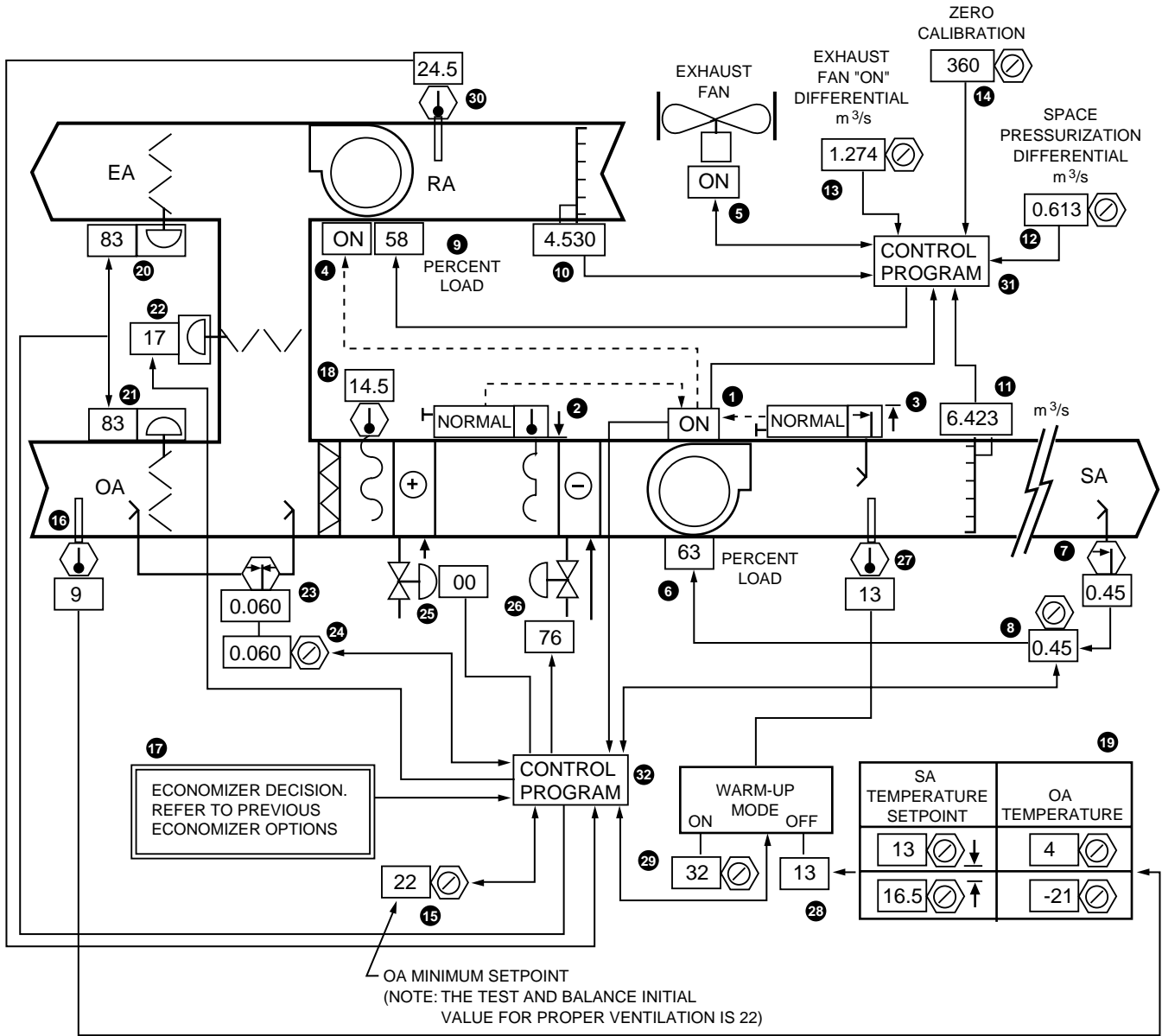

M15182

Item No.

Function

- 1-5 Control system energizes when supply fan is turned on (See FAN SYSTEM START-STOP CONTROL).
- 6-8 Supply fan loads to maintain duct static pressure at the end of the longest run.
- 9-14 Return fan loads to track supply airflow minus exhaust airflow minus air for pressurization.
- 15 Manual positioning value determines minimum summer ventilation mixing damper position. This position is fixed for the OA and

- 16
- 17
- 18

- relief air dampers; but is a minimum position for the return air damper, the value of which will be overridden to maintain a constant mixing box negative static pressure and thus a constant OA airflow.
- OA determines SA temperature setpoint.
- Economizer enables free cooling when OA is suitable.
- Mixed air temperature is for operator information.

- 19 SA temperature setpoint is reset based upon OA temperature.
- 20-22 Mixing dampers modulate for free cooling.
- 23,24 Mixing box static pressure maintained constant during noneconomizer mode by modulation of the RA damper during minimum ventilation periods to maintain constant OA airflow.
- 25-27 Hot water valve, mixing dampers, and chilled water valve modulated in sequence to maintain SA temperature setpoint.
- 28,29 SA temperature setpoint switches from cooling to heating value during warm-up modes.
- 30 RA temperature determines end of warm-up mode.
- 32 Control program coordinates return fan airflow setpoint, loading, exhaust fan control, and fan interlock.
- 33 Control program coordinates temperature control of mixing dampers, control valves, and fan interlock.

FEATURES

1. The system admits outdoor air for cooling based upon the economizer program decision.
2. Supplies constant temperature variable volume (energy conserving) air to VAV boxes during cooling mode.
3. Provides constant airflow of OA in summer with varying supply airflow.
4. Return fan airflow varies with supply fan airflow dependent upon exhaust and pressurization requirements.
5. Provides 100% RA during warm-up periods.
6. Perimeter boxes provide heat when required.
7. SA temperature setpoint is reset based upon OA temperature.

NOTE: This function has no hardware cost. The setpoint parameters are easily adjusted and can be nulled by setting the -21°C OA SA setpoint the same as the 4°C OA SA setpoint.

CONDITIONS FOR SUCCESSFUL OPERATION

1. Skilled HVAC technicians required for pressure and volumetric setup.
2. Test and balance OA damper minimum position value and mixing box static pressure setpoint value..
3. OA and RA dampers maintained and provided with proper actuators (with positioners if pneumatic).
4. Airflow elements and transducers kept clean and calibrated.

SPECIFICATIONS

See FAN SYSTEM START-STOP CONTROL.

Anytime the supply fan runs, the return fan shall start and the control system shall be enabled. Also, anytime the supply fan runs during scheduled occupancy periods, mixing dampers shall position to minimum ventilation position and the exhaust fan shall start.

Anytime the economizer mode is enabled, the temperature controls shall be enabled to override the AHU mixing dampers minimum ventilation setpoint for free cooling as required.

During noneconomizer occupied periods the RA damper shall be modulated to maintain a constant mixing box negative static pressure.

The supply fan loading shall be under EPID control with a start value of 20% and ramp duration of 150 seconds. The supply fan shall load to provide design static pressure at the end of the longest duct.

The return fan loading shall be dependent upon the supply fan airflow. When in the recirculating mode, the return fan airflow setpoint shall equal the supply fan airflow plus a positive or negative value for calibration (of flow elements and transducers) so as to provide a neutral space static pressure. Anytime the OA dampers are not closed completely, the return fan airflow setpoint shall equal the supply fan airflow minus a value necessary to maintain a slightly positive (0.01 Pa) space static pressure. Anytime the exhaust fan operates, the return fan airflow setpoint shall be further reduced by additional airflow value equal to the exhaust airflow (this exhaust value shall be determined by observing the space static pressure as the exhaust fan starts and stops).

The SA temperature shall be under EPID control with a start value of 33 (at which point the hot and chilled water valves are closed and the mixing damper override signal is zero) and a ramp duration of 120 seconds. The hot and chilled water valves and the mixing dampers shall be modulated in sequence to maintain the SA temperature setpoint.

Anytime the optimum start perimeter zone space temperature sensor is less than 21°C at startup time, the SA temperature setpoint shall be 32°C until the RA temperature rises to 23.5°C, at which time the SA temperature setpoint shall be lowered to the cooling SA setpoint. The SA EPID shall be invoked at the switching of the setpoint to cooling with a start value of 33 and a ramp duration of 180 seconds. The cooling SA setpoint shall rise from 13°C to 16°C as the OA temperature drops from 4°C to -21°C.

PSYCHROMETRIC ASPECTS

In the following chart it is assumed that:

1. Outdoor air condition is 35°C DB and 26°C WB.
2. RA condition is 24°C DB and 14.5°C WB.
3. Coil leaving air temperature 10°C.
4. 80% OA.

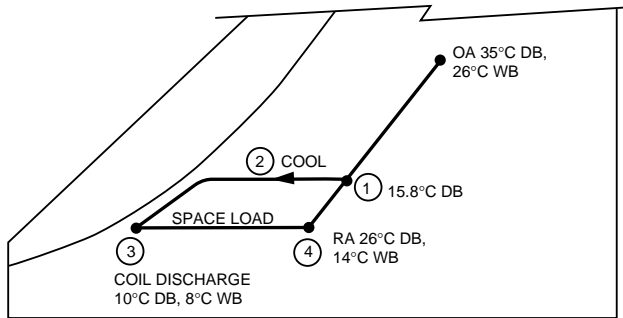

C3266

The following results are obtained:

Item No.	Explanation
1.	RA mixes with 20 percent (minimum position) outdoor air to obtain mixed air condition.
2.	Air entering the coil is cooled along a line of constant moisture content until saturation is approached. Near saturation the moisture content is reduced as the air is cooled. This process involves both latent and sensible cooling.
3.	Mixed air is cooled and dehumidified by cooling coil to obtain cooling coil leaving air condition.
4.	Reheat coils and/or space heats air to 24°C DB and 14.5°C WB.

ASHRAE PSYCHROMETRIC CHARTS

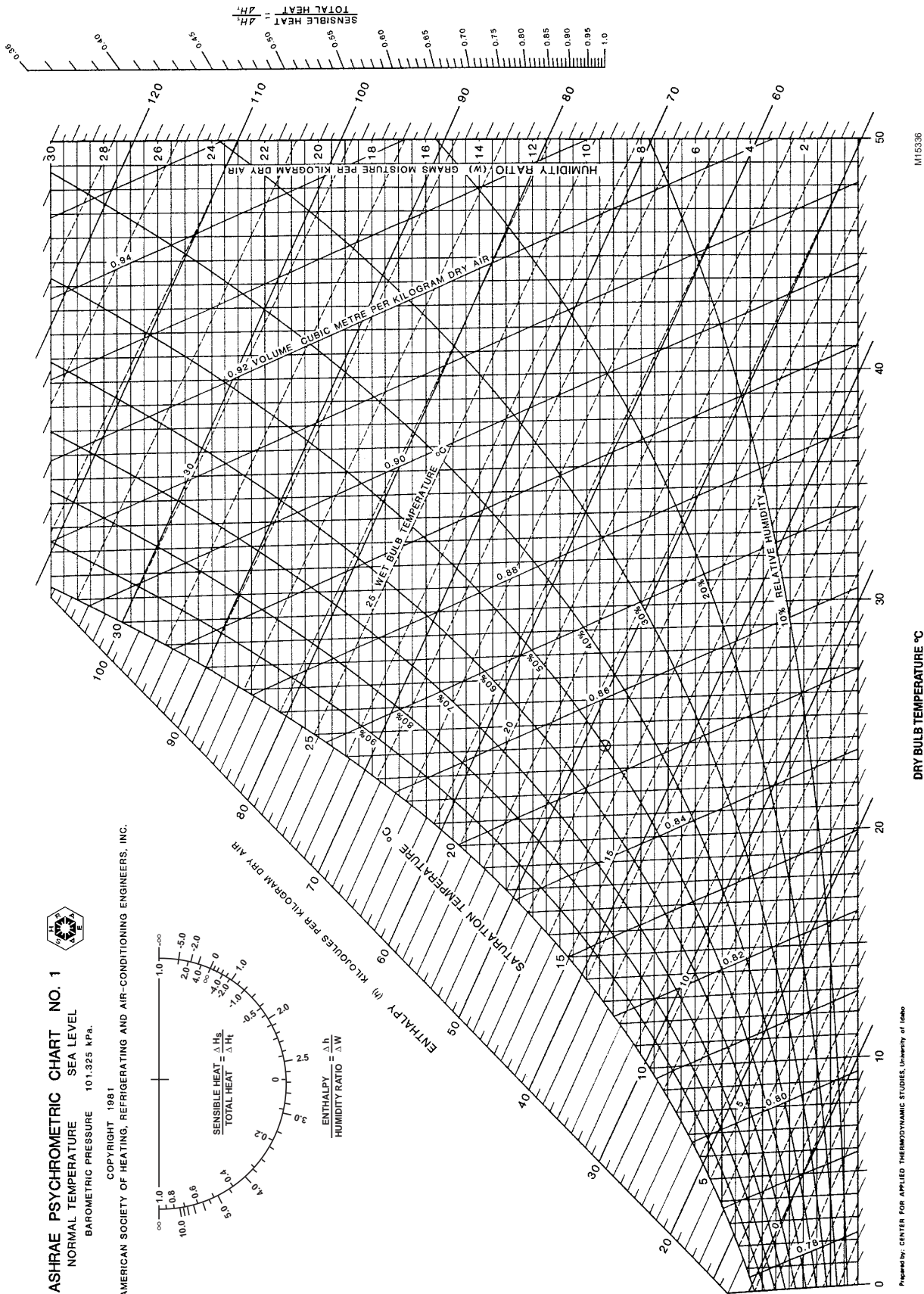

ASHRAE PSYCHROMETRIC CHART NO. 1

NORMAL TEMPERATURE SEA LEVEL
BAROMETRIC PRESSURE 101.325 kPa.

COPYRIGHT 1981
AMERICAN SOCIETY OF HEATING, REFRIGERATING AND AIR-CONDITIONING ENGINEERS, INC.

Prepared by: CENTER FOR APPLIED THERMODYNAMIC STUDIES, University of Idaho

DRY BULB TEMPERATURE °C

M15336

ASHRAE Psychrometric Chart No. 1.

ASHRAE PSYCHROMETRIC CHART NO. 2
 LOW TEMPERATURE -40°C to 10°C SEA LEVEL
 BAROMETRIC PRESSURE 101.325 kPa.

COPYRIGHT 1981
 AMERICAN SOCIETY OF HEATING, REFRIGERATING AND AIR-CONDITIONING ENGINEERS, INC.

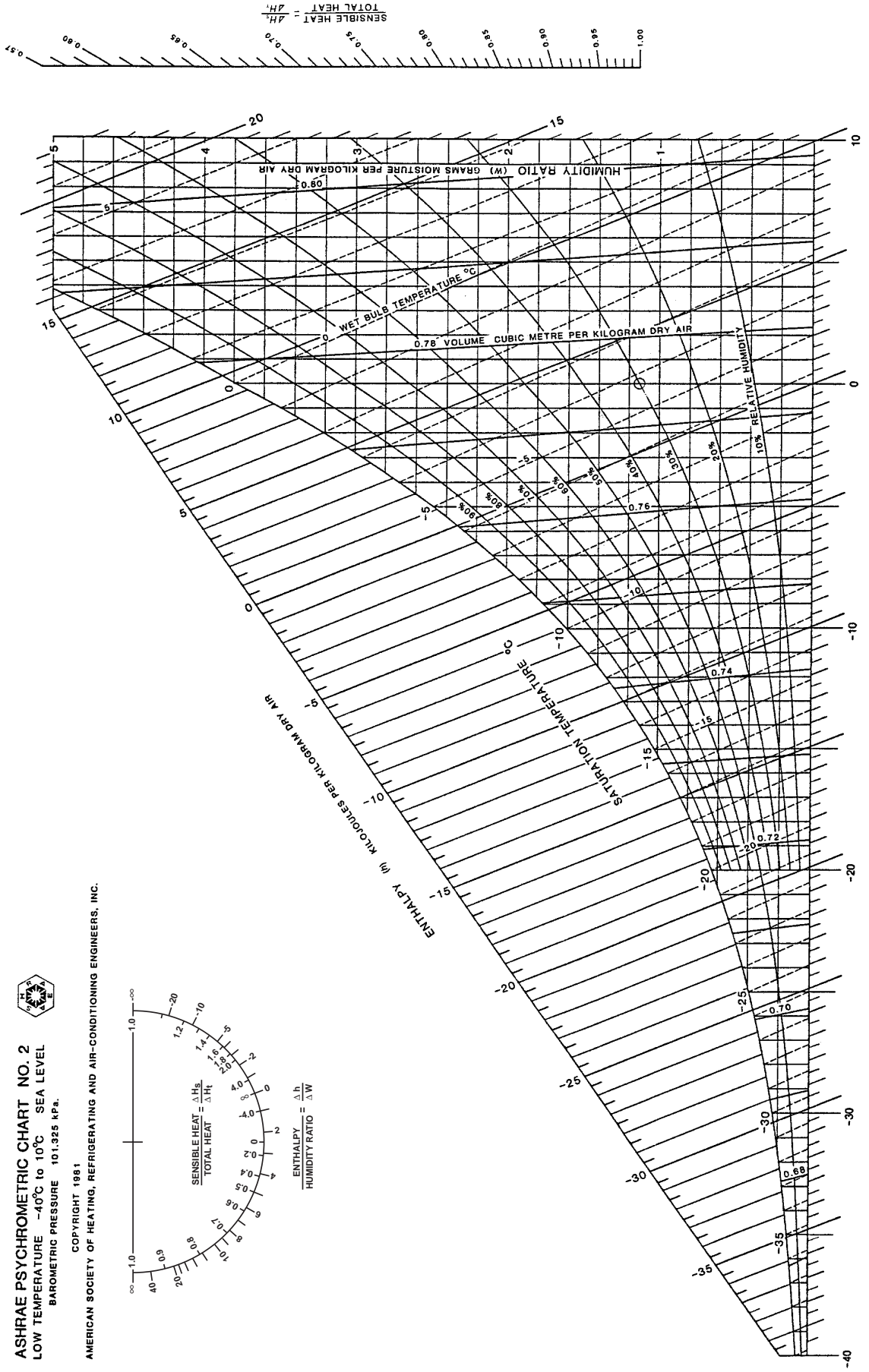
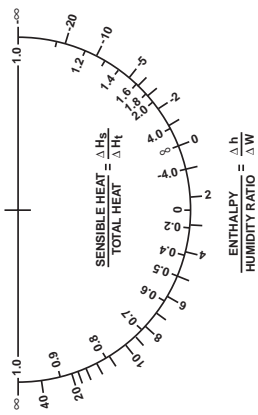

Prepared by: CENTER FOR APPLIED THERMODYNAMIC STUDIES, University of Idaho

DRY BULB TEMPERATURE °C

M15335

ASHRAE Psychrometric Chart No. 2.

Building Airflow System Control Applications

ENGINEERING MANUAL OF AUTOMATIC CONTROL

CONTENTS

Introduction	265
Definitions	265
Airflow Control Fundamentals	266
Need for Airflow Control	266
What is Airflow Control	266
Types of Airflow Systems	267
Variable Air Volume	267
Constant Air Volume	267
Variable Versus Constant Air Volume	268
Ventilation	268
Pressurization	270
Building Pressure Balance	270
Containment Pressurization	270
Wind Pressure Effects	271
Stack Effect	271
Characteristics of Fans and Fan Laws	271
General	271
Fan Types	272
Fan Performance Terms	272
Fan Laws	273
Fan Power	273
Duct System Curves	273
Fan Curve and System Curve Comparison	273
Characteristics of Airflow in Ducts	274
General	274
Pressure Changes Within a Duct	274
Effects of Fittings	276
Effects of Dampers	276
Effects of Air Terminal Units	276
Measurement of Airflow in Ducts	277
General	277
Pressure Sensors	277
Pitot Tube Sensors	277
Total and Static Pressure Sensors	278
Airflow Measuring Devices	279

Airflow Control Applications	280
Central Fan System Control	280
Supply Fan Control for VAV Systems	280
General	280
Duct Static High-Limit Control	281
Return Fan Control for VAV Systems	281
Open Loop Control	281
Direct Building Static Control	282
Airflow Tracking Control	282
Duct Static Control	283
Relief Fan Control for VAV Systems	283
Return Damper Control for VAV Systems	283
Sequencing Fan Control	285
Other Control Modes	285
Warm-Up Control	285
Smoke Control	285
Night Purge Control	285
Zone Airflow Control	285
Airflow Tracking/Space Static Pressure	285
Multiple Fan Systems	287
Exhaust System Control	287
Types	287
Fume Hoods	287
Laboratory Pressurization	288
References	290

INTRODUCTION

This section explains the need for airflow control in a central air handling system, describes the various means of airflow measurement, provides fan and duct characteristics, and discusses suggested means of airflow control. The final control system design depends, of course, on specific job requirements.

There are several types of airflow control that relate directly to the control of airflow in a central air handling system. These types of airflow control include space pressurization, zone pressurization, and exhaust air control. Space or zone pressurization is used when an enclosed area within a building (e.g., a clean room, hospital space, laboratory, fire and smoke control area) must be kept at a positive or negative pressure so

contaminated air does not migrate to unwanted areas. Basic types of space pressure control are static pressure, airflow tracking, and constant airflow. Exhaust air control regulates the amount of air exhausted to keep it at the minimum safe level. Space pressure control is generally required with exhaust air control, and control of airflow in a central air handling system is generally required with space pressure control and/or exhaust air control.

For information on air terminal units used in building airflow control system applications, refer to the Individual Room Control Applications section.

DEFINITIONS

Airflow: The rate at which a volume of air moves through a duct. In this section, airflow is denoted Q and is measured in cubic meters per second (m^3/s). Airflow is derived:

$$Q = A \times V_{\text{AVG}}$$

Where:

$$Q = \text{Airflow in } \text{m}^3/\text{s}$$

$$A = \text{Cross-sectional area of duct in square meters (m}^2\text{)}$$

$$V_{\text{AVG}} = \text{Average velocity}$$

Axial fan: A propeller type fan where airflow within the wheel is substantially parallel to the shaft and in-line with the duct. Axial fan airflow can be controlled by speed, variable inlet vanes, or variable pitch blades depending on the fan type.

Centrifugal fan: A fan where airflow within the wheel is substantially radial to the shaft and the air must make two turns before being expelled from the fan housing. Centrifugal fan airflow can be controlled by speed, variable inlet vanes, or less commonly by dampers.

Constant Air Volume (CAV) system: A central fan system in which airflow in the duct is maintained at a constant volume.

Differential: The difference between supply and return airflows necessary to maintain a positive or a negative pressure in an area. For example, if supply airflow is $1.0 \text{ m}^3/\text{s}$ and return airflow is $0.8 \text{ m}^3/\text{s}$, the differential (positive) is $0.2 \text{ m}^3/\text{s}$. The $0.2 \text{ m}^3/\text{s}$ surplus leaves the building through exhaust fans or vents and exfiltration.

Duct: A circular or rectangular tube for conveying air.

Duct cross-sectional area: For round ducts, the duct cross-sectional area is πr^2 , where r is the radius. For rectangular ducts, the duct area is X times Y , where X and Y are the height and width dimensions. In this section, a duct cross-sectional area is measured in square meter (m^2).

Duct diameter: For round ducts, the diameter is twice the radius ($2r$). For rectangular ducts, an equivalent diameter is derived: $2XY \div (X + Y)$, where X and Y are the height and width.

Fan surge: A condition that occurs when air passing over the fan blades causes a stall. A fan surge causes a fluctuation in duct static pressure and an increase noise level.

Flow Measuring Station (FMS): A device containing multiple static pressure sensors and multiple total pressure sensors manifolded separately for instantaneously measuring average pressures across the face of a duct.

Impact tube: A sensing device with a single opening that points directly into the airstream for measuring total pressure.

Manometer: An instrument for measuring low pressure such as static pressure.

Pitot tube: A sensing device containing both an impact tube and a static pressure tube in a single probe.

Static pressure: The pressure created by air (whether in motion or not) confined in an enclosed area such as a duct or building due to its potential energy. Static pressure, denoted SP , is exerted perpendicularly on all interior walls of the enclosure (duct or building) with respect to a reference pressure outside the enclosure. When static pressure is above atmospheric pressure it is positive and when below atmospheric pressure it is negative.

Static pressure sensor or tube: A sensing device with several holes perpendicular to an airstream for measuring static pressure.

Total pressure: The algebraic sum of Velocity Pressure (VP) plus Static Pressure, denoted TP. Total pressure is derived:

$$TP = VP + SP$$

Turndown: The relationship, in percent, between the maximum minus the minimum airflow to the maximum airflow.

$$\text{Turndown \%} = \left(\frac{\text{Max Flow} - \text{Min Flow}}{\text{Max Flow}} \right) \times 100$$

For example, in a system with a maximum airflow of 1 m³/s and minimum airflow of 0.2 m³/s, the turndown is 80 percent.

Variable Air Volume (VAV) system: A central fan system in which airflow in the duct varies depending on the instantaneous load requirements of the connected VAV terminal units.

Velocity: The speed or rate of flow of the air stream in a duct. In this section, velocity is denoted V and is measured in meters per second (m/s). See General Engineering Data section.

- **Average Velocity**—The sum of the air velocities from equal area increments of a duct cross-section divided by the number of increments. Average velocity, denoted V_{AVG}, is derived:

$$V_{AVG} = \sum (V_1 + V_2 + V_3 + \dots + V_N) / N$$

Where

N = Number of duct increments

- **Peak Velocity**—The greatest air velocity occurring in an increment of a duct cross-section. Peak velocity is denoted V_{PK}.

- **Velocity Pressure:** The pressure created by air moving at a velocity due to its kinetic energy. Velocity pressure, denoted VP, is always exerted in the direction of airflow and is always a positive value. Velocity pressure and velocity are related by the equation:

$$V = \sqrt{VP \frac{2}{Da}}$$

Where:

V = Velocity in m/s

VP = Velocity pressure in pascals (Pa)

Da = Density of the air flowing in the duct measured in kilograms per cubic meter (kg/m³)

The density of air (Da) is 1.2 kg/m³ (at 20°C, 101.325 kPa atmospheric pressure, and 50 percent relative humidity). With this data, the relationship of velocity to velocity pressure is simplified:

$$V = \sqrt{VP \frac{2}{1.2}}$$

This equation reduces to:

$$V = 1.3\sqrt{VP}$$

See General Engineering Data section for Velocity vs. Velocity Pressure table.

AIRFLOW CONTROL FUNDAMENTALS

NEED FOR AIRFLOW CONTROL

Proper control of airflow is important to physiological principles including thermal and air quality considerations. Air distribution systems, containment pressurization, exhaust systems, and outdoor air dilution are examples of airflow control systems used to meet ventilation requirements. Life safety requirements are also met with fire and smoke control systems using airflow control functions. Therefore, an understanding of airflow control is required to provide the various locations in a building with the necessary conditioned air.

One means of maintaining indoor air quality is to dilute undesirable materials (e.g., carbon dioxide, volatile organic compounds) with outdoor air. It is important to understand the control of outdoor air airflow rates in order to:

- Increase outdoor airflow rates when needed for dilution ventilation
- Prevent excessive building and space pressurization
- Minimize outdoor airflow rates when possible to limit energy costs

WHAT IS AIRFLOW CONTROL

In HVAC systems, a well designed combination of fans, ducts, dampers, airflow sensors, static pressure sensors, air terminal units, and diffusers is necessary to provide conditioned air to the required spaces. The function of airflow control is to sense and control the static pressures and airflows of the building. The static pressures occur in ducts and building spaces; airflows occur in ducted air supplies, returns, and exhausts.

TYPES OF AIRFLOW SYSTEMS

An air handling system can provide heating, cooling, humidification, and dehumidification as well as variable quantities of outdoor air. Air handling systems can be classified as single-path or dual-path. The single-path system has all heating and cooling coils in series in a duct. The single duct supplies all terminal equipment. The dual-path system has a cooling coil in one duct and a heating coil (or just return air) in another duct. Both ducts supply dual-duct terminal equipment or multizone dampers.

These systems are further classified (ASHRAE 1996 HVAC Systems and Equipment Handbook) as follows:

Single-Path Systems:

- Single duct, constant air volume
- Single zone systems
- Reheat systems, single duct-variable air volume
- Simple variable air volume
- Variable air volume, reheat
- Single duct, variable air volume-induction
- Single duct, variable air volume-fan powered
- Constant fan, intermittent fan

Dual-Path Systems:

- Dual duct, single fan-constant air volume
- Single fan, constant air volume reheat
- Variable air volume
- Multizone

The more common types of air handling systems are:

- Single duct, variable air volume
- Single duct, constant air volume

VARIABLE AIR VOLUME

A Variable Air Volume (VAV) system controls primarily the space temperature by varying the volume of supply air rather than the supply air temperature (Fig. 1). The interior zones of most large buildings normally require only cooling because of occupancy and lighting loads. Air terminal units serve these zones and operate under thermostatic control to vary the airflow in the individual spaces to maintain the required temperature. The perimeter zones can have a varying load depending on the season and exposure. Heating may be supplied via reheat coils that operate under thermostatic control while air terminal units maintain minimum airflow.

Airflow in the supply duct varies as the sum of the airflows through each VAV terminal unit varies. In light load conditions, the air terminal units reduce the airflow. As more cooling is required, the units increase airflow. Air terminal units typically have controls to limit maximum and minimum airflow and compensate for variations in supply duct static.

To ensure that all air terminal units have sufficient pressure to operate, a supply airflow control system is required. To monitor duct static, static pressure sensors are installed near the end of the supply duct. When VAV terminal unit dampers open, the static drops in the supply duct. The static pressure sensor detects the static pressure drop and the airflow control system increases the supply fan output. The opposite occurs when the VAV terminal unit dampers close.

Another VAV system feature is that the difference in airflow between the supply and return fans (and not the position of the outdoor air damper) determines the amount of minimum outdoor air ventilation delivered by the supply system. For example, Figure 1 shows a single duct VAV system for a building with the fans on and outdoor air dampers at minimum position. The design condition for the supply fan is 14.0 m³/s and the return fan is 12 m³/s. The 2 m³/s difference is lost through kitchen and restroom exhaust fans (0.7 m³/s) and exfiltration (1.3 m³/s). Thus 2.0 m³/s of outdoor air must be brought in through the supply fan to make up the difference. Depending on mixed air system pressure drops, even if all dampers in the mixed air system are fully open, the outdoor air volume will be 2.0 m³/s. To increase outdoor air volume, it is necessary to modulate the return air damper. This airflow control provides a slightly positive building static pressure with respect to outdoor air in a properly designed system.

As supply air volume is reduced, so is return air volume. The return air fan is normally sized smaller than the supply fan. Flow measuring stations are located in both the supply and return ducts so that the return air fan can track the airflow of the supply fan with a constant flow differential. Thus, as airflow through the supply fan reduces, the control system reduces the airflow of the return fan. This control system can maintain either a fixed airflow difference or a percentage of supply airflow difference. For more information on VAV systems, see AIRFLOW CONTROL APPLICATIONS.

CONSTANT AIR VOLUME

A Constant Air Volume (CAV) system controls space temperature by altering the supply air temperature while maintaining constant airflow. Since the airflow is constant, the system design provides sufficient capacity to deliver supply air to the space for design load conditions. In many systems, reheat coils allow individual space control for each zone and provide heating when required for perimeter zones with different exposure. The CAV system shown in Figure 2 has the same interior and perimeter zone load requirements as the VAV system in Figure 1. The CAV system, however, does not use static pressure sensors and flow measuring stations since the airflow is constant.

In a CAV system, the supply and return fans are manually set to meet the total airflow needs. The cooling coil discharge temperature can be reset as a function of the zone having the greatest cooling load. This improves operating efficiency. The reheat coils on the constant volume boxes are controlled by individual space thermostats to establish the final space temperatures.

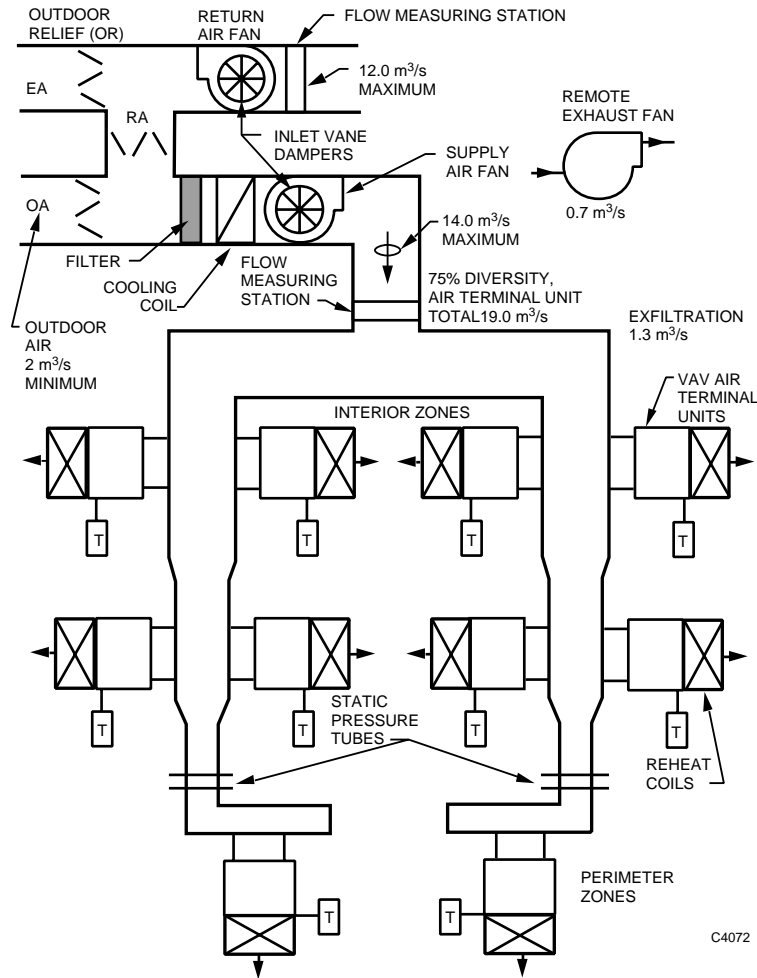

Fig. 1. Single Duct Variable Air Volume System.

VARIABLE VERSUS CONSTANT AIR VOLUME

Sizing of central equipment is based on climate conditions which indicate heating and cooling loads. In a CAV system, typically outdoor air is supplied, cooled, distributed to the various zones, and then reheated for the individual needs of each space. The sizing of the central equipment is based on the sum of the loads from all air terminal units served by the CAV system. In Figure 2 for a single duct CAV system, the maximum load from all air terminal units is 18.9 m³/s. Therefore, the supply fan is sized for 18.9 m³/s and, with 2.4 m³/s exhaust, the return fan is sized for 16.5 m³/s.

The diversity of the heating and cooling loads in a VAV system permits the use of smaller central equipment. If a building with a VAV system has glass exposures on the east and west sides, the solar load peaks on the two sides at different times. In addition, due to building use, offices and conference rooms on the east and west sides are never fully occupied at the same time. The interior spaces do not use reheat and receive only the amount of cooling required. Perimeter zones use reheat, but only at minimum airflow. Therefore, the instantaneous load of the VAV system central equipment is not the sum of the

maximum loads from all air terminal units. Instead, the maximum instantaneous load on the central equipment of a VAV system is a percentage of the sum of all maximum individual loads. This percentage can vary for different buildings.

In Figure 1 for a single duct VAV system, the maximum air terminal unit load is 18.9 m³/s with a diversity of 75 percent. This means that the supply fan is sized for only 14.0 m³/s. Similarly the return fan is sized for 12.0 m³/s instead of 16.5 m³/s and the coils, filters, and ducts can also be downsized.

VENTILATION

Care must be used to assure that the AHU ventilation design complies with relevant codes and standards which are frequently revised. Ventilation within a constant air volume system is often a balancing task. During occupied, non-economizer periods of operation, the mixing dampers are positioned to bring in the required OA. The system balancing person determines the specific minimum ventilation damper position.

If this is done on a VAV system at design load, as the VAV boxes require less cooling and less airflow, the supply fan capacity reduces, and the inlet pressure to the supply fan becomes less negative as the fan unloads. As the filter inlet pressure becomes less negative, less OA is drawn into the system which is unacceptable from a ventilation and IAQ perspective. VAV systems therefore require design considerations to prevent non-economizer occupied mode ventilation from varying with the cooling load. This may be accomplished in several ways.

The dampers may be set at design load as for a constant air volume system, and the filter inlet pressure noted. Then the noted filter inlet negative pressure can be maintained by modulating the return air damper. Keeping this pressure constant keeps the OA volume constant. This method is simple but requires good maintenance on the OA damper and linkage, positive positioning of the OA damper actuator, and the balancing person to provide the minimum damper position and the pressure setpoints.

Another positive method is to provide a small OA injection fan set to inject the required OA into the AHU mixing box during occupied periods (the OA damper remains closed). The fan airflow quantity may be controlled by fan speed adjustment or inlet damper setting and sensed by an airflow measuring station for closed loop modulating control. This basic method is positive and relatively maintenance free, but like the pressure control method, it requires a balancing person to make adjustments. This closed loop control method is more costly and requires keeping the airflow pickup/sensor clean, but it allows simple setpoint entry for future adjustments.

A minimum OA damper may be provided for the occupied OA volume requirement. An airflow measuring station in the minimum OA duct is required to modulate the minimum OA damper in sequence with the RA damper to maintain a constant volume of OA. This method is more costly than the first method, but it allows convenient software setpoint adjustments.

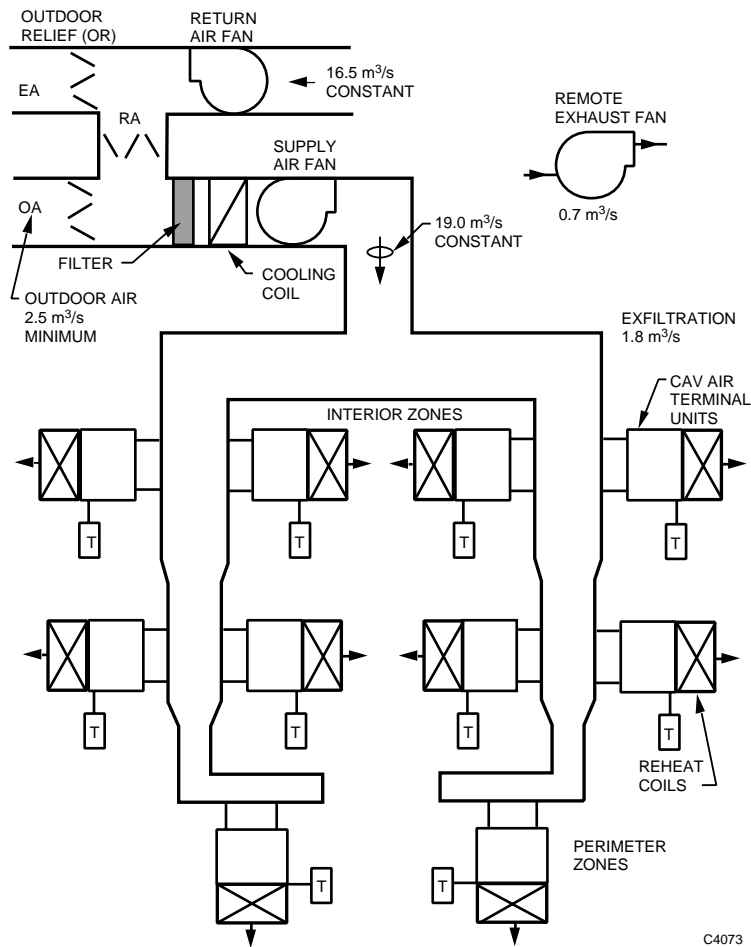

Fig. 2. Single Duct Constant Air Volume System.

Theoretically, the mixing dampers may be modulated to maintain a constant OA volume during occupied periods using an OA duct airflow measuring station. Since, in these examples, the OA duct is sized for 100 percent OA, the minimum is usually 20 to 25 percent of the maximum. The airflow velocity at minimum airflow is extremely low, and velocity pressure measurement is usually not practical. Hot wire anemometer velocity sensing at these velocities is satisfactory, but costly, and requires that the sensing element be kept clean to maintain accuracy. (Filtering the entering OA is helpful.) A smaller, minimum OA damper and duct may also be used to assure adequate airflow velocity for velocity pressure measurement.

If a return fan and volumetric tracking return fan control are used, and no relief/exhaust dampers exist, or if the RA damper is closed and the MA damper is open during occupied non-economizer modes, the OA volume equals the SA volume minus the RA volume. This method is simple and low cost but is only applicable when building exhaust and exfiltration meets minimum ventilation requirements.

Where minimum OA only is provided (no economizer dampers), variations of any of these methods may be used. See the Air Handling System Control Applications section for further information.

PRESSURIZATION

Building pressurization and ventilation are important aspects of airflow control. A building or areas within a building can be pressurized for positive, negative, or sometimes neutral static pressure to control the flow of air from one area to another. A building can use positive static pressure to eliminate infiltration drafts, possible dirt, and contamination from outside sources. Areas within a building such as laboratories can use negative pressure to prevent contamination and exfiltration to adjacent spaces and zones. Proper building pressurization must also consider the effects of outdoor wind pressure and stack effect or vertical air differences.

BUILDING PRESSURE BALANCE

The pressures in a building must be balanced to avoid airflow conditions which make it difficult to open and close doors or conditions which cause drafts. Buildings have allowable maximum and minimum static pressures that control these conditions. A force of 130 through 220 newtons is considered the maximum reasonable force to open a door. The equation used to calculate the force to overcome the pressure difference across a door as well as to overcome the door closer is as follows:

$$F = F_{DA} + \frac{K_d \times W \times A \times \Delta p}{2 \times (W - D)}$$

Where:

- F = Total door opening force applied at the knob in newtons (N)
- F_{DA} = Force to overcome the door closer, applied at the knob, in newtons (N). This force is normally between 13 and 90N.
- W = Door width in meters (m)
- A = Door area in square meters (m²)
- ΔP = Differential static pressure across the door in pascals (Pa)
- D = Distance from the door knob to the knob side of the door in meters (m)

Rearranging the equation to calculate the differential pressure results in the following:

$$\Delta p = \frac{|(F - F_{DA})| \times [2 \times (W - D)]}{W \times A}$$

EXAMPLE:

Calculate the differential pressure for a 0.9m wide x 2.1m high door that has a 130N opening force, a 45N force to overcome the door closer, and 0.08m between the door knob and the door edge.

$$\Delta p = \frac{|(130 - 45)| \times [2 \times (0.9 - 0.08)]}{0.9 \times 1.89}$$

$$\Delta p = 82.0 \text{ Pa}$$

Similarly, the maximum pressure difference which overcomes a 45N door closer is as follows:

$$\Delta p = \frac{|(0 - 45)| \times [2 \times (0.9 - 0.08)]}{0.9 \times 1.89}$$

$$\Delta p = |43.4| \text{ Pa}$$

CONTAINMENT PRESSURIZATION

In an airflow system for a building that requires containment pressurization, the direction of infiltration is toward the space with the contaminants. The direction is controlled by regulating the pressure differentials between the spaces. For example, a laboratory is typically kept at a negative pressure relative to surrounding spaces so that any infiltration is into the laboratory. The static pressure difference required for containment varies with the specific application. In buildings with areas that require smoke control, a minimum static pressure difference of 5.0 through 10.0 Pa is suggested to control cold smoke. (Cold smoke is generated when water spray from a sprinkler system cools smoke from a building fire.)

WIND PRESSURE EFFECTS

Wind effects generate surface pressures which can change supply and exhaust fan capacities, infiltration and exfiltration of air, and interior building pressure. Wind can affect environmental factors (e.g., temperature, humidity, and air motion), dilution ventilation, and control of contaminants from exhausts.

The pressure exerted by wind on a building surface can be calculated from the following equation:

$$P_w = C_w \frac{D_a \times V^2}{2}$$

Where:

- P_w = Wind pressure in pascals (Pa)
- C_w = Dimensionless pressure coefficient ranging from -0.8 for leeward walls through 0.8 for windward walls
- D_a = density of air in kilograms per cubic meter (kg/m^3)
- V = Wind velocity in kilometers per hour (km/h)

EXAMPLE:

For a wind velocity of 11 km/h and a pressure coefficient of -0.8 (leeward side), the wind pressure on the building is as follows:

$$P_w = -0.8 \frac{1.2 \times 11^2}{2}$$

$$P_w = -58 \text{ Pa}$$

STACK EFFECT

Stack effect or thermal buoyancy is the difference between indoor and outdoor temperature which causes a pressure difference that affects air movement in a building. Whenever outdoor air is colder than indoor air, the building draws in air near the base (infiltration) and expels air near the top (exfiltration). Conversely, when outdoor air is warmer than indoor air, the building draws in air near the top (infiltration) and expels air near the base (exfiltration).

The level of the building at which the differentials of indoor and outdoor static pressures are equal (with zero wind speed) is called the *neutral pressure level* or *neutral plane* (Fig. 3). Location of the neutral plane depends on the distribution of outdoor openings. If one large opening dominates building leakage, the neutral plane is found close to that opening. For vertical openings uniformly distributed, the neutral plane is at midheight. In general, the neutral plane for tall buildings varies from 0.3 through 0.7 of total building height.

Stack effect can be calculated from the following equation:

$$\Delta P = 4200K_t \times \left(\frac{1}{T_o} - \frac{1}{T_i} \right) \times h$$

Where:

- ΔP = Pressure difference in pascals (Pa)
- T_o = Outdoor absolute temperature in degrees kelvin($^{\circ}\text{F}$) ($273 + ^{\circ}\text{K}$)
- T_i = Indoor absolute temperature in degrees kelvin($^{\circ}\text{F}$) ($273 + ^{\circ}\text{K}$)
- h = Height of building in meters (m)
- K_t = Thermal draft coefficient (dimensionless, varies from 0.63 to 0.82 depending upon tightness of floor separation relative to that of the exterior walls)

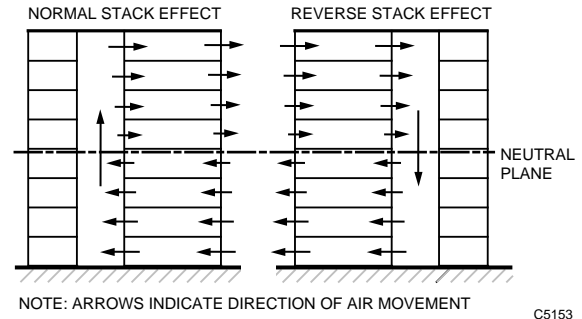

Fig. 3. Stack Effect in a Building.

CHARACTERISTICS OF FANS AND FAN LAWS

NOTE: This text provides an overview of fan characteristics and fan laws. For more information, see the Trane Air Conditioning Manual listed in REFERENCE.

GENERAL

In airflow systems, a fan converts mechanical, rotative energy into fluid energy. This is basically accomplished by a wheel or propeller which imparts a forward motion to the air. For HVAC applications, fans rarely exceed a total pressure of 3.0 kPa.

Fans must be properly installed to achieve smooth control and correct performance. In general, manufacturer recommendations should be followed and the following noted (from Engineering Fundamentals of Fans and Roof Ventilators, Plant Engineering, Copyright 1982):

- Fans should be located so the discharge of one does not enter the intake of another fan.
- Intake area should be at least 20 percent greater than the fan wheel discharge area.
- Fans located opposite from each other should be separated by at least six fan diameters.
- Elbows or other abrupt duct transformations on the discharge side of the fan should not be closer than one diameter from the fan wheel.
- Direction of fan discharge and rotation should be selected to match duct or mounting requirements.

FAN TYPES

Two main types of fans are used in airflow systems centrifugal and axial:

Centrifugal Fans: A centrifugal fan (Fig. 4) has airflow within the wheel that is substantially radial to the shaft (or away from the axis of the shaft). The air from an in-line centrifugal fan does not have to turn before being expelled from the fan housing. Some centrifugal fan designs are differentiated by the inclination of the blades. Each blade design has a peculiar advantage:

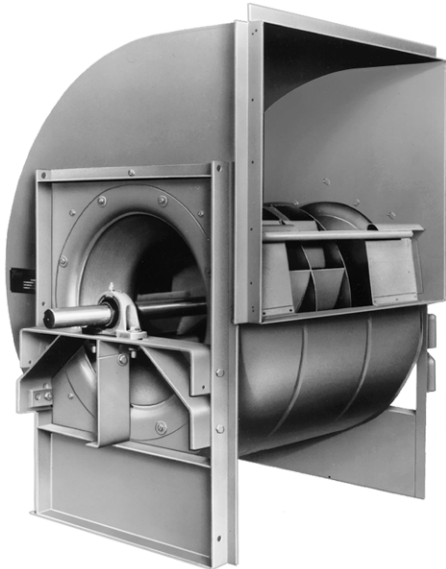

Photo Courtesy of the Trane Company

Fig. 4. Centrifugal Fan.

- Backward inclined blades are generally larger and more quiet than forward inclined blades. They are more suitable for larger sizes.
- Forward inclined blades are suitable in small packaged units and operate at a lower static pressure.
- Air foil blades are backward inclined, and are efficient and quiet due to an air foil shaped blade. Generally these are used on the largest fans.

Axial Fans: An axial fan has airflow through the wheel that is substantially parallel to the shaft (or along the axis of the shaft). Various designs of axial fans are available (Fig. 5), mainly differentiated by the duty of the fan. Each design has a peculiar advantage:

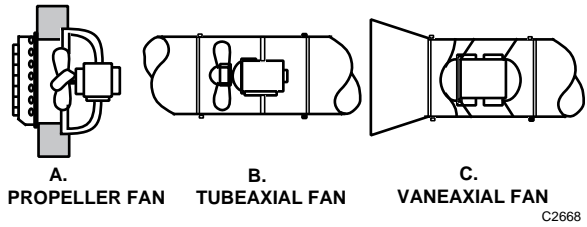

Fig. 5. Types of Axial Fans.

- Propeller fans are low pressure, high airflow, noisy fans. They work up to a maximum static pressure of 190 Pa.
- Tubeaxial fans are heavy-duty propeller fans arranged for duct connection. They discharge air with a motion that causes high friction loss and noise. They work up to a maximum static pressure of 0.75 kPa.
- Vaneaxial fans are basically tubeaxial fans with straightening vanes added to avoid spiraling air patterns. They are space efficient, quieter than tubeaxial fans, and work at static pressures up to 2.5 kPa.

FAN PERFORMANCE TERMS

The following are terms used when discussing fan performance:

Fan volume: The airflow passing through the fan outlet. Generally this fan outlet value is only slightly less than the airflow at the fan inlet because specific volume changes due to air compression are small.

Fan outlet velocity: The fan volume divided by the fan outlet area. This velocity is a theoretical value because, in reality, the velocity pattern at the outlet of a fan is not easy to measure.

Fan Static Pressure (FSP): The fan total pressure minus the fan velocity pressure ($FSP = FTP - FVP$). It can be calculated by subtracting the total pressure at the fan inlet from the static pressure at the fan outlet.

Fan Total Pressure (FTP): The difference between the total pressure at the fan inlet and the total pressure at the fan outlet. The FTP value measures the total mechanical energy added to the air by the fan.

Fan Velocity Pressure (FVP): The velocity pressure corresponding to the fan outlet velocity.

FAN LAWS

Fan laws (Table 1) are simple and useful when dealing with changing conditions. Three important laws deal with speed changes:

1. Airflow varies directly with the fan speed. For example, doubling the fan speed (rpm) doubles the airflow (m³/s) delivery.
2. Static pressure varies as the square of the fan speed. For example, doubling the fan speed (rpm) develops four times the static pressure (Pa).
3. Power varies as the cube of the fan speed. For example, doubling the fan speed (rpm) requires eight times the fan power (Po).

Table 1. Fan Laws

Variable	When Speed Changes	When Density Changes
Airflow	Varies DIRECT with Speed Ratio $m^3/s_2 = m^3/s_1 \left(\frac{RPM_2}{RPM_1} \right)^1$	Does Not Change
Pressure	Varies with SQUARE of Speed Ratio $P_2 = P_1 \left(\frac{RPM_2}{RPM_1} \right)^2$	Varies DIRECT with Density Ratio $P_2 = P_1 \left(\frac{D_2}{D_1} \right)$
Power	Varies with CUBE of Speed Ratio $Po_2 = Po_1 \left(\frac{RPM_2}{RPM_1} \right)^3$	Varies DIRECT with Density Ratio $Po_2 = Po_1 \left(\frac{D_2}{D_1} \right)$

FAN POWER

The *theoretical* fan power (Po) required to drive a fan is the fan power required if there were no losses in the fan (100 percent efficiency). The fan power formula is:

$$\text{Theoretical } P_o = (m^3/s \times FTP)$$

Where:

- m³/s = Quantity of air
- Po = Power in watts (W)
- FTP = Fan total pressure.

Fan power is the actual fan power required to drive the fan.

$$P_o = \text{Theoretical } P_o \div \text{Fan efficiency}$$

$$= (m^3/s \times FTP) \div \text{Fan efficiency}$$

The fan power is always larger than the theoretical fan power due to inefficiencies. The *actual* power of the fan can be determined only by testing.

DUCT SYSTEM CURVES

Fan unit duct systems have a certain amount of friction, or resistance, to the flow of air. Once this resistance of the duct system is known for a specific volume of airflow, a curve can be drawn based on the relationship:

$$\frac{P_2}{P_1} = \left(\frac{m^3/s_2}{m^3/s_1} \right)^2$$

This formula is merely another way of stating that pressure (P) changes as the square of the airflow (m³/s).

The system curve (also called system resistance, duct resistance, or system characteristic) is similar to Figure 6.

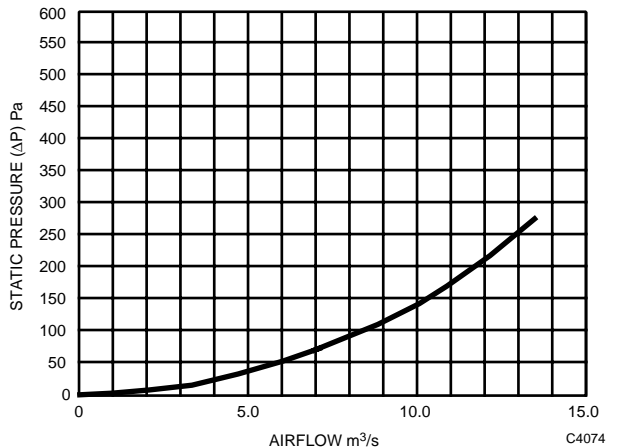

Fig. 6. System Curve.

FAN CURVE AND SYSTEM CURVE COMPARISON

In order to deliver the required air quantity, a fan must be selected that can overcome the duct resistance. However, because of dampers repositioning and other equipment changes, resistance of the duct may change. The results of such conditions can be seen in Figure 7.

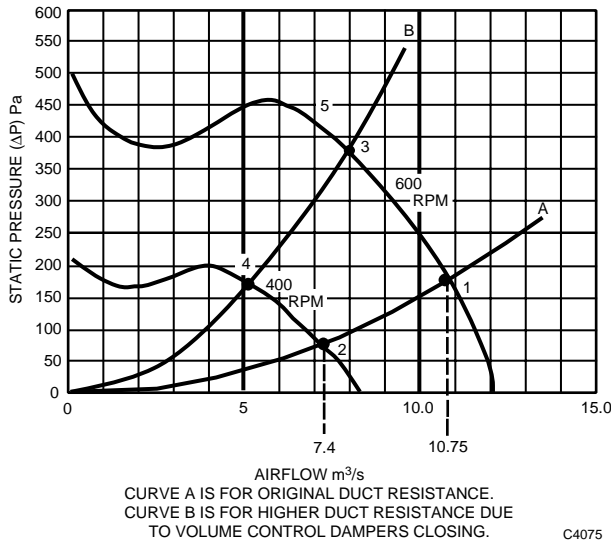

Fig. 7. Combination of Fan and System Curves.

The fan curves shown are for a fan running at two speeds, 400 rpm and 600 rpm. Also, two system curves, A and B, have been plotted. The intersection of the system curves and the fan curves indicate the quantities of air the fan will provide. With System Curve A, if the fan is running at 600 rpm, it will deliver 10.75 m³/s at 180 Pa (Point 1). With the same system curve (A), if the fan is running at 400 rpm, it will deliver 7.4 m³/s at 75 Pa (Point 2).

System Curve B shows increased resistance of the duct system due to dampers throttling or filters clogging. With System Curve B, if the fan is running at 600 rpm, it will deliver 8.0 m³/s at 380 Pa (Point 3). With the same system curve (B), if the fan is running at 400 rpm, it will deliver 5.1 m³/s at 170 Pa (Point 4).

CHARACTERISTICS OF AIRFLOW IN DUCTS

GENERAL

Supply and return ducts can be classified by application and pressure (ASHRAE 1996 Systems and Equipment Handbook). HVAC systems in public assembly, business, educational, general factory, and mercantile buildings are usually designed as commercial systems. Air pollution control systems, industrial exhaust systems, and systems outside the pressure range of commercial system standards are classified as industrial systems.

Classifications are as follows:

- Residences**—±125 Pa to ±250 Pa.
- Commercial Systems**—±125 Pa to ±2.5 kPa.
- Industrial Systems**—Any pressure.

The quantity of air flowing in a duct can be variable or constant, depending on the type of system. See TYPES OF AIRFLOW SYSTEMS.

PRESSURE CHANGES WITHIN A DUCT

For air to flow within a duct, a pressure difference must exist. The fan must overcome friction losses and dynamic (turbulent) losses to create the necessary pressure difference. Friction losses occur due to air rubbing against duct surfaces. Dynamic losses occur whenever airflow changes velocity or direction. The pressure difference required to move air must be sufficient to overcome these losses and to accelerate the air from a state of rest to a required velocity.

In HVAC systems, the air supplied by the fan includes two types of pressures: velocity pressure and static pressure. Velocity pressure is associated with the motion of air and is kinetic energy. Static pressure is exerted perpendicularly to all walls of the duct and is potential energy. Velocity and static pressure are measured in pascals (Pa). Total pressure is the sum of the static and velocity pressure and, therefore, is also measured in pascals.

In an airflow system, the relationship between velocity pressure and velocity is:

$$V = 1.3\sqrt{VP}$$

NOTE: See Velocity Pressure in DEFINITIONS for a derivation of this formula.

If the velocity and duct size are known, the volume of airflow can be determined:

$$Q = AV$$

Where:

- Q = Airflow in cubic meters per second (m³/s)
- A = Cross-sectional area of duct in square meters (m²)
- V = Velocity in meters per second (m/s)

Examples of the relationships between total, velocity, and static pressures are shown in Figure 8A for positive duct static pressures and Figure 8B for negative duct static pressures. When static pressure is above atmospheric pressure it is positive and when below atmospheric pressure it is negative. The examples use U-tube manometers to read pressure. The sensor connected to the U-tube determines the type of pressure measured.

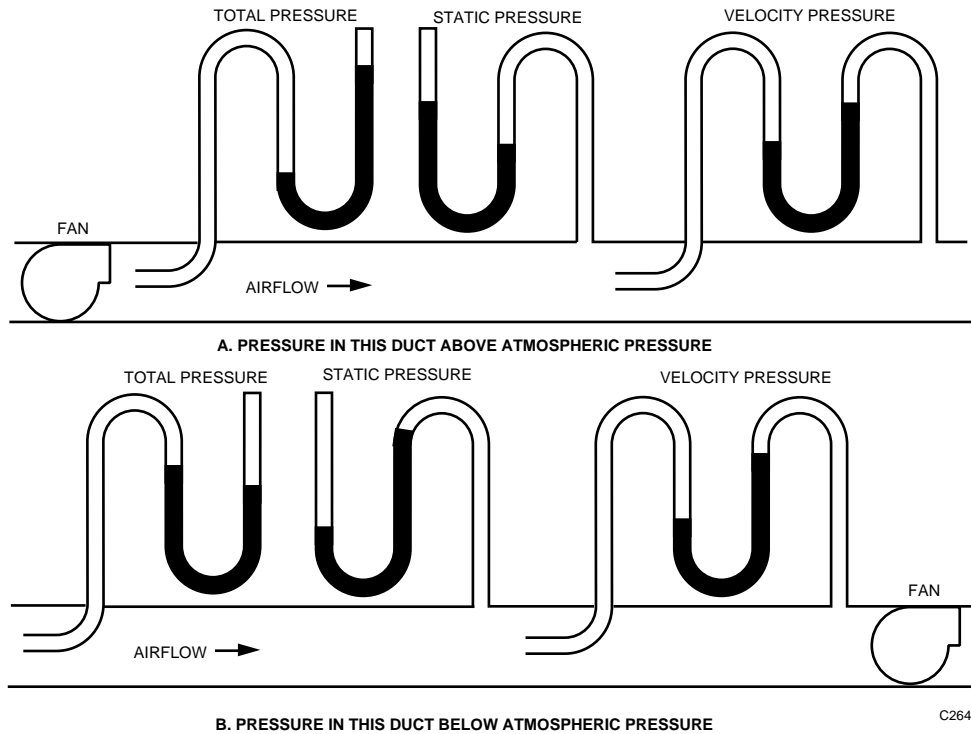

Fig. 8. Relationships of Total, Static, and Velocity Pressures for Positive and Negative Duct Static Pressures.

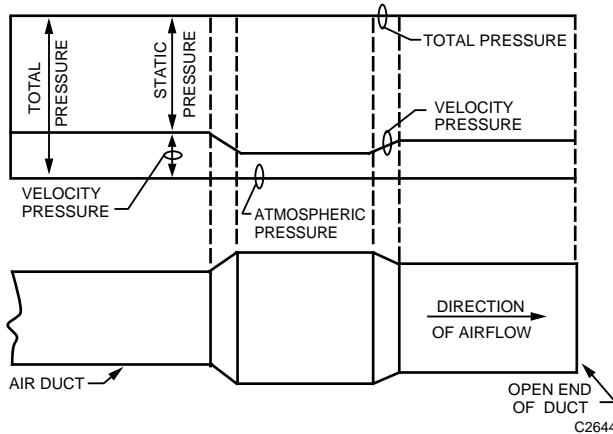

Fig. 9. Theoretical Changes in Pressure with Changes in Duct Area.

In a theoretical duct system without friction losses, the total pressure is constant along the entire duct (Fig. 9). The static and velocity pressures, however, change with every change in the duct cross-sectional area. Since the velocity decreases in larger duct sections, the velocity pressure also decreases, but the static pressure increases. When theoretical ducts change size, static pressure is transformed into velocity pressure and vice versa.

An actual duct system (Fig. 10) encounters a phenomenon called pressure loss or friction loss. Pressure loss is caused by friction between the air and the duct wall. Dynamic losses also occur due to air turbulence caused by duct transitions, elbows, tees, and other fittings. At the open end of the duct in Figure 10, the static pressure becomes zero while the velocity pressure depends solely on the duct size. The pressure loss due to friction

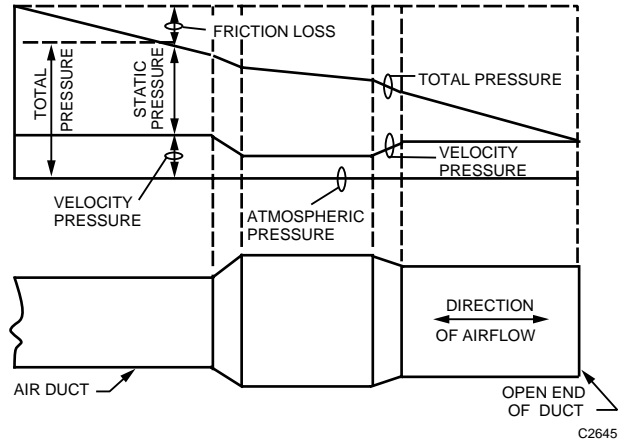

Fig. 10. Actual Changes in Pressure with Changes in Duct Area.

appears to be a static pressure loss. However, in reality the total pressure decreases because the pressure loss due to friction also indirectly affects the air velocity in the duct. When the duct inlet and outlet sizes are identical, the velocity pressures at both places are equal and the difference in static pressure readings actually represents the pressure loss due to friction.

In most applications, the duct outlet is larger than the duct inlet (velocity is lower at the outlet than at the inlet). When the duct size increases, a small part of the initial velocity pressure is converted into static pressure and lost as friction loss (Fig. 11). This concept is called static regain. Similar to water flow through a pipe, a larger airflow through a given duct size causes a larger pressure loss due to friction. This pressure drop or friction loss cannot be regained or changed to static or velocity pressure.

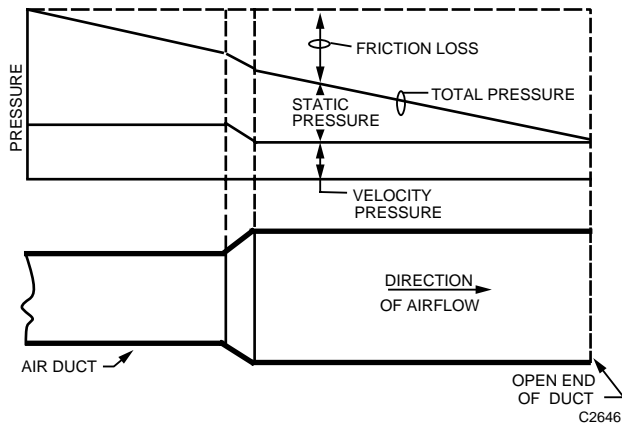

Fig. 11. Pressure Changes in a Duct with Outlet Larger than Inlet.

The size of a duct required to transport a given quantity of air depends on the air pressure available to overcome the friction loss. If a small total pressure is available from the fan, the duct must be large enough to avoid wasting this pressure as friction loss. If a large total pressure is available from the fan, the ducts can be smaller with higher velocities and higher friction losses. Reducing the duct size in half increases the velocity and the friction loss increases.

In most low pressure airflow systems, the velocity component of the total pressure may be ignored because of its relative size. For example, if a supply fan delivers 5 m³/s at 500 Pa static pressure in a supply duct that is 1m x 1.25m (or 1.25m²), the Velocity ($V = Q \div A$) is 5 m³/s \div 1.25m² or 4 m/s. The Velocity Pressure [$VP = (V \div 1.3)^2$] is $(4 \div 1.3)^2 = 9.47$. The velocity pressure is 1.9 percent of the static pressure at the fan [$(9.47 \div 500) \times 100 = 1.9\%$].

In most high pressure airflow systems, the velocity pressure does become a factor. For example, if a supply fan delivers 5 m³/s at 1500 Pa static pressure in a round supply duct that is 0.6m in diameter or 0.28m², the Velocity ($V = Q \div A$) is 5 m³/s \div 0.28m² or 17.9 m/s. The Velocity Pressure [$VP = (V \div 1.3)^2$] is $(17.9 \div 1.3)^2$ or 190 Pa. The velocity pressure is 12.7 percent of the static pressure at the fan [$(190 \div 1500) \times 100 = 12.7\%$].

EFFECTS OF FITTINGS

Ducts are equipped with various fittings such as elbows, branch takeoffs, and transitions to and from equipment which must be designed correctly to prevent pressure losses.

In elbows, the air on the outside radius tends to deflect around the turn. The air on the inside radius tends to follow a straight path and bump into the air on the outer edge. This causes eddies in the air stream and results in excessive friction losses unless prevented. Turning vanes are often used in elbows to reduce the friction loss. In addition, they provide more uniform and parallel flow at the outlet of the elbow.

In transitions to and from equipment an attempt is made to spread the air evenly across the face of the equipment. If the diverging section into the equipment has too great an angle, splitters are often used. The splitters distribute the air evenly and reduce friction losses caused by the air being unable to expand as quickly as the sides diverge. In converging sections friction losses are much smaller, reducing the requirement for splitters.

EFFECTS OF DAMPERS

Dampers are often used in ducts for mixing, for face and bypass control of a coil, for volume control, or for numerous other air volume controls. Figure 12 shows the velocity profile in a straight duct section. Opposed blade dampers are recommended where there are other system components downstream of the damper such as coils or branch takeoffs as they do not adversely distort the air velocity profile. Parallel blade damper can be used where the airflow discharges into a free space or a large plenum.

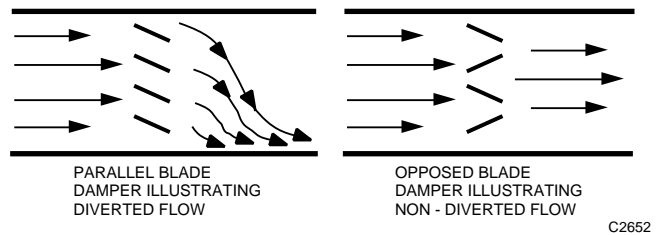

Fig. 12. Velocity Profile of Parallel Blade vs Opposed Blade Damper.

EFFECTS OF AIR TERMINAL UNITS

A variety of air terminal units are available for air handling systems. For VAV systems, the single duct, Variable Constant Volume (VCV), throttling type air terminal unit (Fig. 13) is typically used. With this device, the space thermostat resets the setpoint of an airflow controller, varying the volume of conditioned air to the space as required. Since a number of these units are usually connected to the supply duct, it is the collective requirements of these units that actually determines the airflow in the main supply duct. In this type of system, the supply fan is controlled to maintain a constant static pressure at a point in the duct system so there is sufficient supply air for all of the air terminal units.

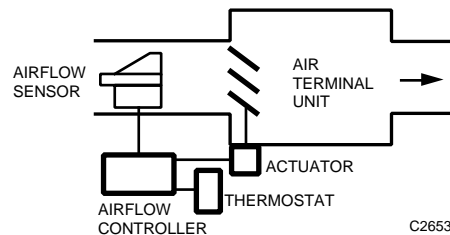

Fig. 13. Single Duct, Variable Constant Volume Air Terminal Unit.

MEASUREMENT OF AIRFLOW IN DUCTS

GENERAL

Total pressure and static pressure can be measured directly; velocity pressure cannot. Velocity pressure is found by subtracting the static pressure from the total pressure. This subtraction is typically done by differential pressure measuring devices.

PRESSURE SENSORS

Some applications require only the measurement of static pressure. To obtain an accurate static pressure measurement, a static pressure sensor (Fig. 14A) is used. This sensor has a closed, bullet-shaped tip followed by small peripheral holes that are perpendicular to the airflow for measuring air pressure. The total pressure sensor (Fig. 14B) is similar except there is an opening in the end of the tube and no openings along the sides.

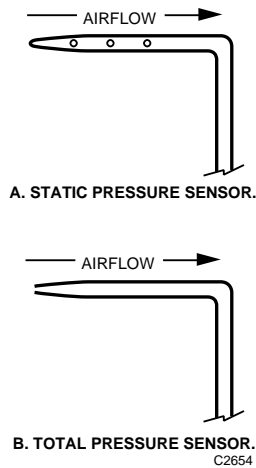

Fig. 14. Pressure Sensors.

PITOT TUBE SENSORS

A pitot tube measures both total pressure and static pressure. This device combines the total pressure sensor and the static pressure sensor tubes into one device (Fig. 15).

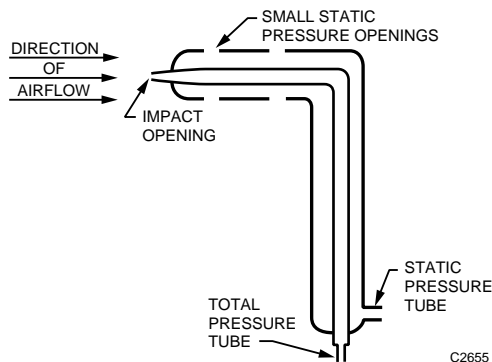

Fig. 15. Pitot Tube.

To obtain accurate velocity pressure readings, the pitot tube tip must point directly into the air stream. Figure 16 shows the error in static and total pressure readings when the pitot tube does not point directly into the air stream. Misaligning a pitot static pressure tube causes the static readings to first increase and then drop off rapidly as the angle of inclination (θ) increases. The total pressure reading drops off gradually and then more rapidly as θ increases. (Modern Developments in Fluid Dynamics, Volume 1, Dover Publications, Copyright 1965.)

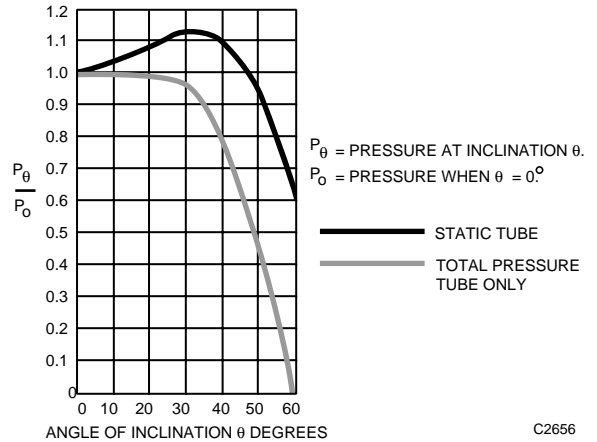

Fig. 16. Error Caused by Improperly Mounting Pitot Tube in Airstream.

The following are guidelines for using pitot tubes:

1. A pitot tube can be used to measure either static or total pressure.
2. A pitot tube measures the velocity at one point. However, several readings across the duct (a traverse) are normally needed to obtain an accurate average velocity.
3. Accurate pressure readings cannot occur in locations with varying swirls, eddies, or impinged air. Because of this:
 - The pitot tube must be inserted into the air stream at least 10 duct diameters downstream from elbows, and five duct diameters upstream of bends, elbows, or other obstructions which cause these effects. (See DEFINITIONS for a description of round and rectangular duct diameters.)
 - Air straightening vanes must be located upstream from a pitot tube location to ensure accurate readings. Rotating airflow can occur in long, straight, duct sections. If air straightening vanes are not used, this nonparallel airflow can strike a pitot tube at an angle and produce false total and static pressure measurements.
4. It is impractical to use the pitot tube (or devices using its principles) at velocities below about 3.5 m/s (velocity pressure of 7.60 Pa).

Even with an inclined manometer, velocity pressures below 7.60 Pa are too small for reliable measurement outside of a well equipped laboratory. According to the Industrial Ventilation Manual 17th Edition, 1982, "A carefully made and accurately

leveled 10:1 inclined manometer calibrated against a hook gauge can read to approximately ± 1.25 Pa. A standard pitot tube with an inclined manometer can be used with the following degree of accuracy:

Table 2. Pitot Tube Accuracy.

Velocity (m/s)	Percent Error (\pm)
20	1.04
15	1.60
10	2.94
4	6.6
3	18.6

It can be seen that the use of the pitot tube in practical applications is limited at velocities lower than 3 to 4 m/s."

An analysis of the accuracy of the pitot tube at 4 m/s follows:

Velocity Pressure:

$$VP = (4 \div 1.3)^2 = 9.467 \text{ Pa}$$

Accuracy:
High

$$9.467 \text{ Pa} + 1.250 \text{ Pa} = 10.717 \text{ Pa}$$

or 4.26 m/s

Low

$$9.467 \text{ Pa} - 1.250 \text{ Pa} = 8.217 \text{ Pa}$$

or 3.73 m/s

Range

$$4.26 \text{ m/s} - 3.73 \text{ m/s} = 0.53 \text{ m/s}$$

or $100.4 \div 2 = \pm 0.265 \text{ m/s}$

Percent Error:

$$(\pm 0.265 \div 4) \times 100 = \pm 6.6\%$$

In practical situations, the velocity of the air stream is not uniform across the cross-section of a duct. Friction slows the air moving close to the walls so the velocity is greater away from the wall.

To determine the average velocity, a series of velocity pressure readings at points of equal area is found. It is recommended to use a formal pattern of sensing points across the duct cross-section. These readings across the duct cross-section are known as traverse readings. Figure 17 shows recommended pitot tube locations for traversing round and rectangular ducts. In round ducts, velocity pressure readings at the centers of the areas of equal concentric

areas are taken. Readings are taken along at least two diameters perpendicular to each other. In rectangular ducts, readings at the centers of equal rectangular areas are taken. The velocities are then mathematically totaled and averaged.

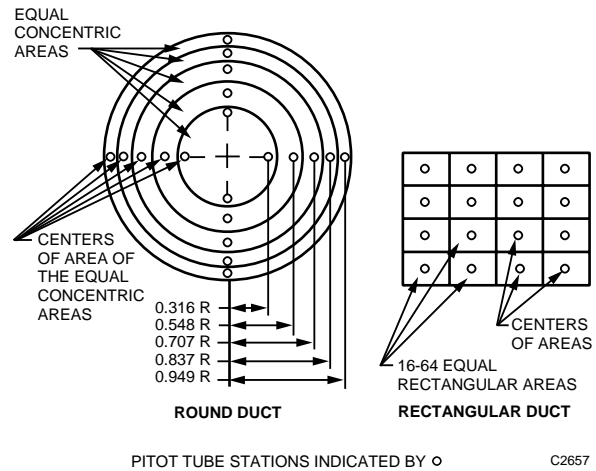

Fig. 17. Pitot Tube Locations for Traversing Round and Rectangular Ducts.

The principle behind the manual pitot tube traverse is simple and straightforward. However, care must be taken to obtain accurate readings without inadvertent violation of the formal traverse pattern. With the manual pitot tube traverse, individual velocity readings must be calculated mathematically, totaled, and divided by the number of readings to obtain average velocity.

TOTAL AND STATIC PRESSURE SENSORS

Other arrangements are available to instantaneously average sensed pressures and manifold these values to the exterior of the duct. The Tchebycheff (Tcheb) tube method (Fig. 18) is one such arrangement. This method separately manifolds the total and static pressure sensors. Inside each manifold is a tube with a single slot which receives an average pressure signal from the manifold. The averaged signals from the total and static pressure tubes may be used for indication and control functions. This method assures an accurate reading of flow conditions and a steady signal.

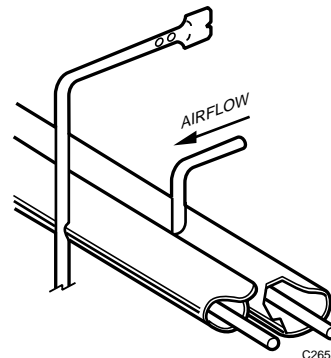

Fig. 18. Tcheb Tube Sensors and Manifold.

AIRFLOW MEASURING DEVICES

Various devices for measuring airflow are available. Figure 19 shows a flow measuring station that consists of:

- An air straightener section to eliminate swirl type airflow and help normalize the velocity profile
- Total pressure sensors aligned into the air stream and spaced on an equal area basis
- Static pressure sensors with ports perpendicular to the airflow direction and positioned on an equal area basis
- Separate manifolds for static and total pressure averaging

The flow measuring station in Figure 19 uses a tube as an air straightener (Fig. 20) with total and static pressure sensors at the downstream end. These tubes are arranged on an equal area basis.

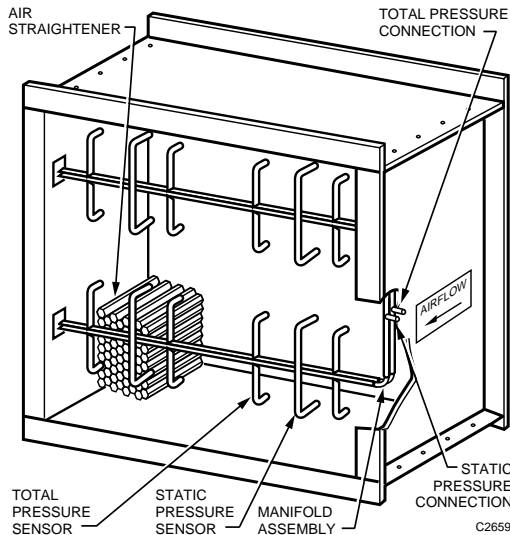

Fig. 19. Averaging Flow Measuring Station.

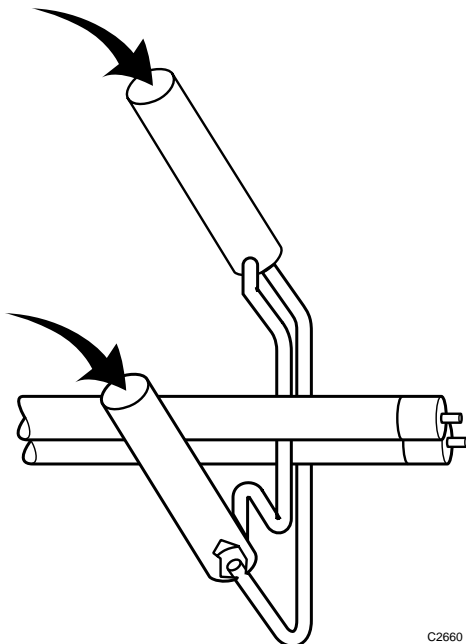

Fig. 20. Air Straighteners/Sensors and Manifolds.

Electronic flow stations use the tube type construction with thermal velocity sensors instead of static and total pressure sensors. Other flow sensing arrangements use holes in round tubing (Fig. 21A and 21B) or airfoil designs (Fig. 21C). It is important to consult the manufacturer of each type of flow station for specifications, calibration data, and application information (location limitations within ducts).

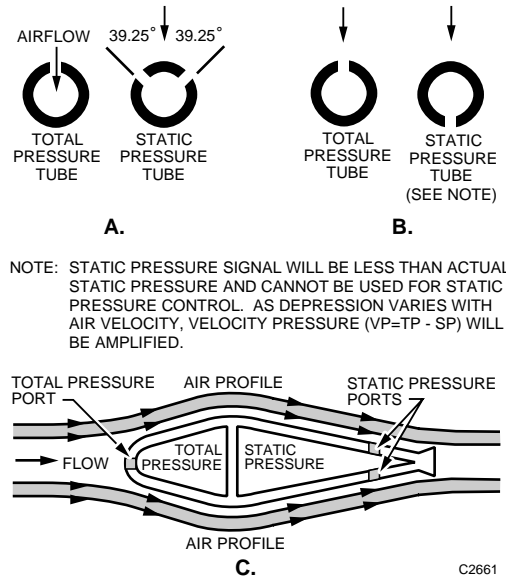

Fig. 21. Miscellaneous Flow Sensing Arrangements.

Figure 22 illustrates an airflow pickup station typically used in the primary air inlet to a VAV air terminal unit. The pickup station consists of two tubes that measure differential pressure. This measurement can be used in an airflow calculation.

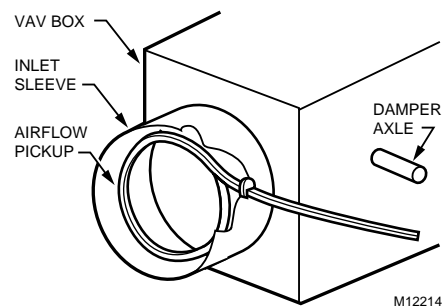

Fig. 22. Airflow Pickup Station for VAV Box Applications.

AIRFLOW CONTROL APPLICATIONS

CENTRAL FAN SYSTEM CONTROL

Figure 23 shows the net airflow balance for a building space and where the return air, outdoor air, and supply fan inlet meet. Assume that the return air damper is open, the relief air damper is closed, and the outdoor air damper is open enough to allow minimum design outdoor air to pass. When the outdoor and relief dampers open further and the return damper closes further, outdoor air increases above minimum. These conditions are used for free cooling (economizer cycle control) and when minimum air must be greater than the difference between supply and return fan airflow rates.

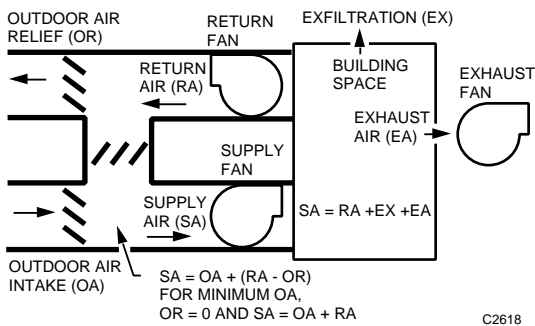

Fig. 23. Central Fan Control with Net Airflow Balance.

SUPPLY FAN CONTROL FOR VAV SYSTEMS

General

The supply fan control system provides adequate duct static pressure to all air terminal units. This duct static pressure at the air terminal unit is used to overcome pressure drops between the air terminal unit inlet and the controlled space. Inadequate static limits maximum airflow to less than required, while excessive duct static increases sound levels and wastes energy. The location of the duct static pressure sensor is critical for proper control of the supply fan.

Ideally, if the supply duct is one simple run with short takeoffs to the air terminal units (Fig. 24A), the duct static pressure sensor is located at the air terminal unit furthest from the supply fan. However, capacity variations of the furthest air terminal unit may adversely influence the duct static pressure sensor. Under these circumstances, the sensor will transmit more stable and uniform pressures if located upstream of the last three or four air terminal units.

Typically, the supply duct is complex with multiple runs or branches. This duct layout requires a compromise in duct static pressure sensor location that is usually about 75 percent of the distance between the fan and the furthest air terminal unit (Fig. 24B). In complex duct runs where multiple branches split close to the fan, sensors should be located in each end of the

branch (Fig. 24C). Each sensed point should have its own setpoint in the control loop. This avoids the assumption that branches and multisensor locations have identical requirements. The sensed point having the lowest duct pressure relative to its own setpoint should control the supply fan.

When a long straight duct (10 diameters) is available, a single point static sensor or pitot tube can be used. When long duct sections are not available, use static or airflow measuring stations which are multipoint and have flow straighteners to provide the most accurate sensing. A reference pressure pickup should be located outside the duct (in or near the controlled space) and adjacent to the duct sensor to measure space static in areas served by the duct. The static pressure sensor should not be located at the control panel in the equipment room if duct static is measured elsewhere. Equipment room static pressure varies as outdoor winds change, outdoor air and relief damper positions change, or exhaust fan operation changes.

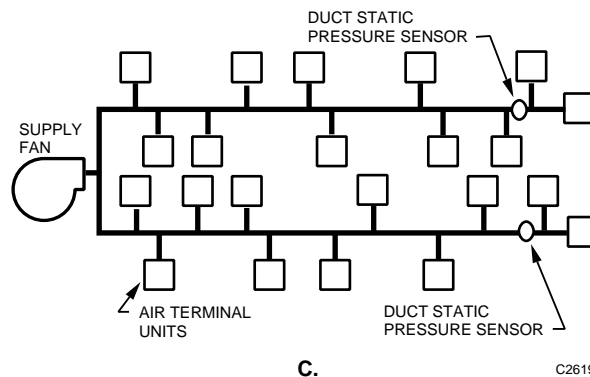
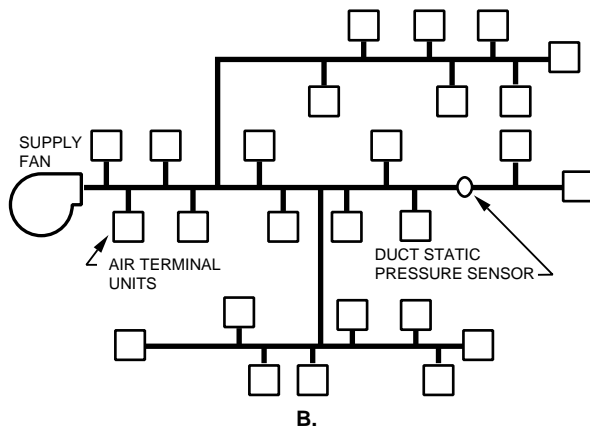
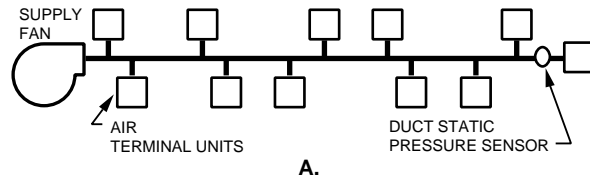

Fig. 24. Locating Duct Static Pressure Sensor for Supply Fan Control.

A wide proportional band setting (10 times the maximum duct static pressure at the fan discharge) on the fan control is a good starting point and ensures stable fan operation. Integral action is necessary to eliminate offset error caused by the wide proportional band. Integral times should be short for quick response. The use of inverse derivative, which essentially slows system response, does not produce the combination of stability and fast response attainable with wide proportional band and integral control modes. (See the Control Fundamentals section for more information on proportional band and integral action.)

Inlet vane dampers, variable pitch blades (vane axial fans), or variable speed drives are used to modulate airflow (both supply and return). Actuators may require positive positioning to deal with nonlinear forces. Variable speed drives, especially variable frequency, provide excellent fan modulation and control as well as maximum efficiency.

Duct Static High-Limit Control

High-limit control of the supply fan duct static should be used to prevent damage to ducts, dampers, and air terminal units (Fig. 25). Damage can occur when fire or smoke dampers in the supply duct close or ducts are blocked, especially during initial system start-up. Fan shut-down and controlling high-limit are two techniques used to limit duct static. Both techniques sense duct static at the supply fan discharge.

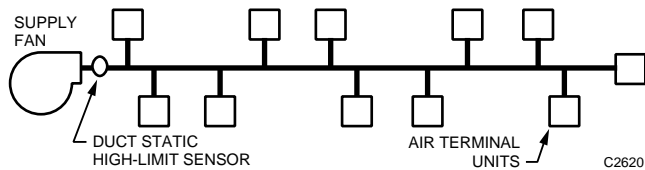

Fig. 25. Duct Static High-Limit Control.

Fan shut-down simply shuts down the fan system (supply and return fans) when its setpoint is exceeded. High-limit control requires a manual restart of the fans and should be a discrete component separate from the supply fan primary control loop. The fan shut-down technique is lowest in cost but should not be used with smoke control systems where continued fan operation is required.

A controlling high-limit application is used when the fan system must continue to run if duct blockage occurs, but its operation is limited to a maximum duct static. For example, a fire or smoke damper in the supply duct closes causing the primary duct static pressure sensor to detect no pressure. This would result in maximum output of the supply fan and dangerously high static pressure if the controlling high pressure limit is not present. A controlling high-limit control will modulate the fan to limit its output to the preset maximum duct static (Fig. 26).

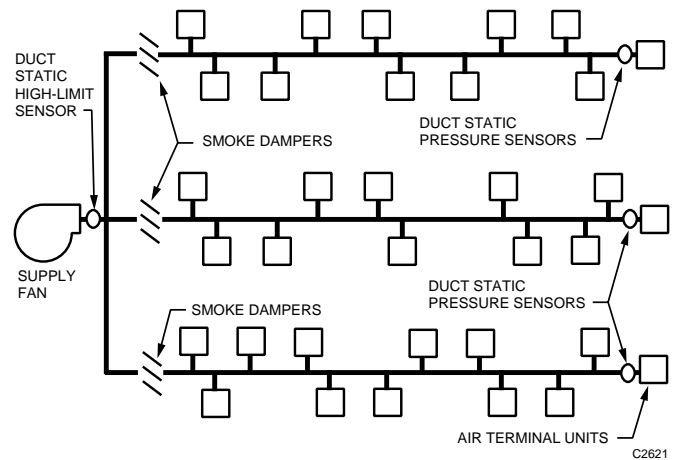

Fig. 26. Controlling Static High-Limit.

RETURN FAN CONTROL FOR VAV SYSTEMS

Return fan operation influences building (space) pressurization and minimum outdoor air. There are four techniques to control the return fan: open loop, direct building static, airflow tracking, and duct static.

Open Loop Control

Open loop control (Fig. 27) modulates the return fan without any feedback. This type of control presumes a fixed relationship between the supply and return fans, controls the return fan in tandem with the supply fan, and changes the output of the return fan without measuring the result. Open loop control requires similar supply and return fan operating characteristics. Therefore, a careful analysis of the supply and return fan operating curves should be done before selecting this technique. Also, accurate balancing is essential to ensure proper adjustment at maximum and minimum operating points. Mechanical linkage adjustments or other means are used to adjust the differential between the two fans for desired flows and to minimize tracking errors at other operating points. With digital control, software can be used to align the fan loading relationships, to vary exhaust effects, and to offset dirty filter effects to minimize flow mismatches.

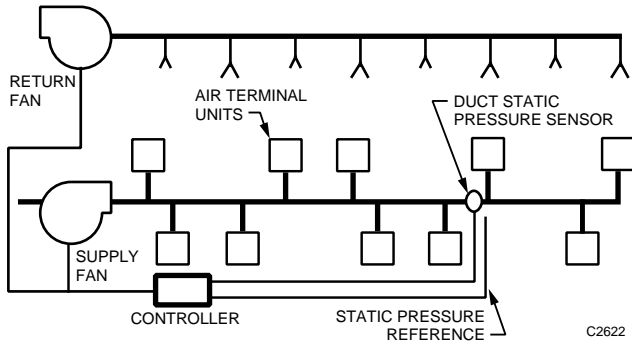

Fig. 27. Open Loop Control.

Open loop control is often acceptable on small systems more tolerant of minimum outdoor air and building pressurization variations. Since open loop control does not sense or control return airflow, changes caused by the return side dampering and exhaust fan exfiltration change the minimum airflow and building pressurization. Systems with low airflow turndowns also are more suitable for open loop control. As a rule, turndowns should not exceed 50 percent.

In a control sequence where the outdoor air damper is closed (e.g., night cycle or morning warm-up), open loop control should not be used. Excessive negative pressurization will occur in the duct between the return and supply fans.

Direct Building Static Control

In direct building static control, the return fan responds directly to the building space static pressure referenced to the static pressure outside of the building (Fig. 28). The location of the building space static pressure sensor should be away from doors opening to the outside, elevator lobbies, and some confined areas. Usually a hallway on an upper floor is suitable. The outdoor static pressure sensor must avoid wind effects and be at least 5 meters above the building to avoid static pressure effects caused by wind. Due to stack effect, this technique should not be used in tall buildings with open spaces or atriums, unless the building has been partitioned vertically. This technique should use proportional plus integral control with a wide throttling range for stable, accurate, and responsive operation.

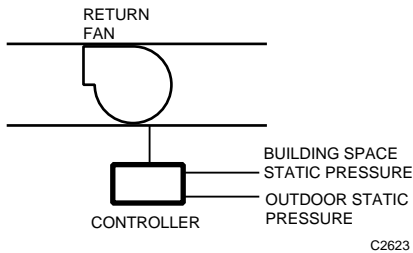

Fig. 28. Direct Building Static Control.

Since building static is controlled directly, the pressure remains constant even when exhaust fan airflow changes. Minimum outdoor airflow varies with changes in exhaust fan airflow and building infiltration/exfiltration. In a control sequence where the outdoor air damper is closed, the building static must be reset to zero and all exhaust fans should be turned off.

Airflow Tracking Control

In airflow tracking (Fig. 29) control, the return fan airflow is reset based on the relationship between supply and exhaust fan airflows. That relationship is usually a fixed difference between the supply total airflow and return plus exhaust total airflow, but it can also be a percentage of supply total airflow. When duct layout prevents measuring of total airflow from one flow station, measurements in multiple ducts are totaled. This technique is usually higher cost, especially when multiple flow stations are required. Airflow tracking control and direct building static control are preferable to open loop control. Proportional plus integral control is necessary for accurate operation.

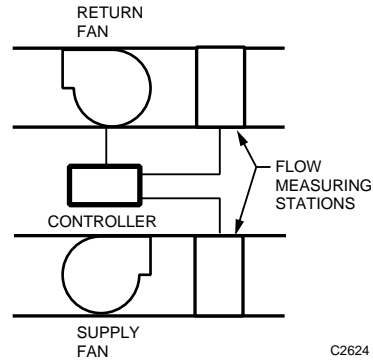

Fig. 29. Airflow Tracking Control for Return Fan.

Minimum outdoor airflow should be maintained at a constant level, independent of exhaust fan airflow and changes in building infiltration/exfiltration. Building space pressurization varies only when building infiltration/exfiltration changes. Exhaust fan airflow must reset the return fan airflow for building pressurization to be independent of exhaust fans. In a control sequence where the outdoor air damper is closed, the differential between supply airflow and return airflow must be reset to zero and all exhaust fans should be turned off.

Refer to the Air Handling System Control Applications section for an example of a VAV AHU WITH RETURN FAN AND FLOW TRACKING CONTROL.

Duct Static Control

Duct static control is similar to supply fan duct static high-limit control, except return duct static pressure is negative. If individual space returns are damper controlled, return fan control must use this technique (Fig. 30). Duct static control is relatively simple, but individual space return controls make the entire system complex.

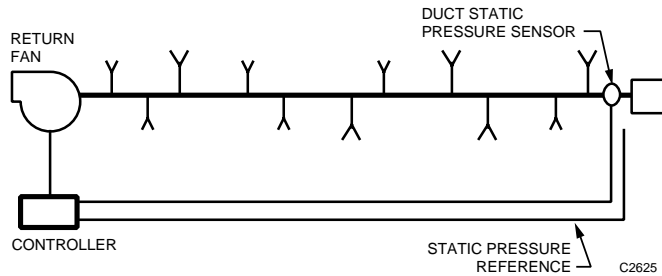

Fig. 30. Duct Static Control.

Minimum building outdoor air is the difference between supply total airflow and return total plus the exhaust fan total airflow. If controlling the space returns from airflow tracking (using dampers), the exhaust fan volume must be included in the tracking control system for constant building and space pressurization. If controlling the space returns by space pressurization, building and space pressurization remain constant regardless of exhaust fan operation.

RELIEF FAN CONTROL FOR VAV SYSTEMS

Relief fans are exhaust fans for the central air handling system. They relieve excessive building pressurization and provide return air removal for economizer cycles.

In Figure 31, a relief damper is located after the relief fan and is controlled to open fully whenever the relief fan operates. Direct building static pressure or airflow tracking controls the relief fan. In direct building static pressure tracking control (Fig. 32), the same guidelines apply as for return fan control. During minimum ventilation cycles and when the outdoor air damper is closed, the relief fan should be turned off and the relief damper closed. In airflow tracking (Fig. 33), flow measuring stations should be located in relief and outdoor air ducts, not in supply and return ducts as with return fans.

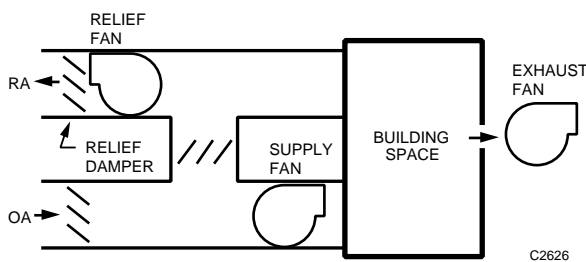

Fig. 31. Relief Damper Location.

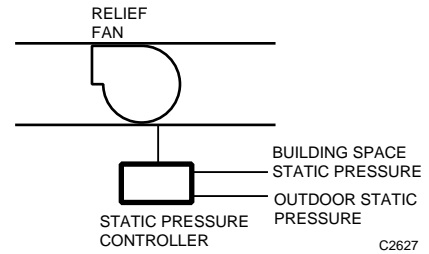

Fig. 32. Direct Building Static Control for Relief Fan.

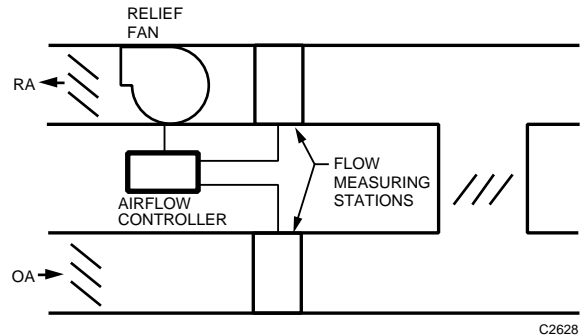

Fig. 33. Airflow Tracking Control for Relief Fan.

RETURN DAMPER CONTROL FOR VAV SYSTEMS

In systems having a return fan, when the mixed air control cycle is not operating, the outdoor air (or maximum outdoor air) and relief dampers are closed and the return damper remains fully open. When the mixed air control cycle is operating, the return damper modulates closed and outdoor air (or maximum outdoor air) and relief dampers modulate open. The return damper should be sized for twice the pressure drop of the outdoor air (or maximum outdoor air) and relief dampers. This prevents the possibility of drawing outdoor air through the relief damper (Fig. 34).

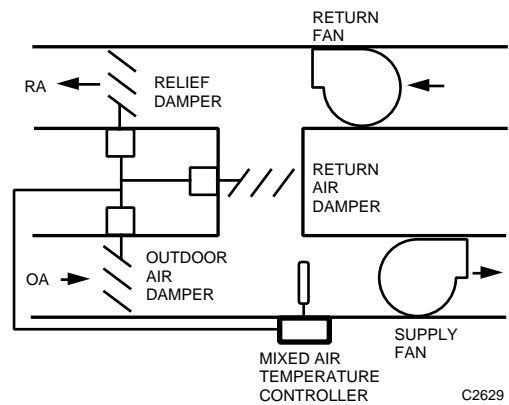

Fig. 34. Return Air Damper Mixed Air Control Cycle.

In systems not having a return air fan, the return damper controls minimum outdoor airflow or building pressurization. Airflow tracking or direct building static pressure control can be used to control the return damper, depending on which parameter is most important. See Figure 35 for airflow tracking and Figure 36 for direct building static pressure control.

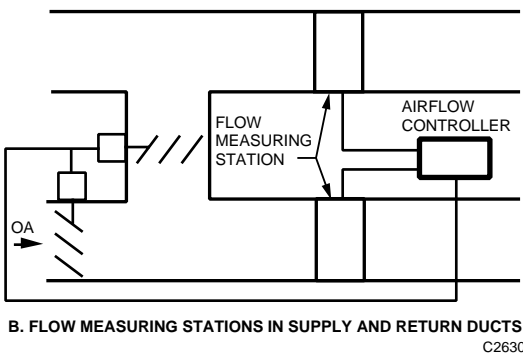
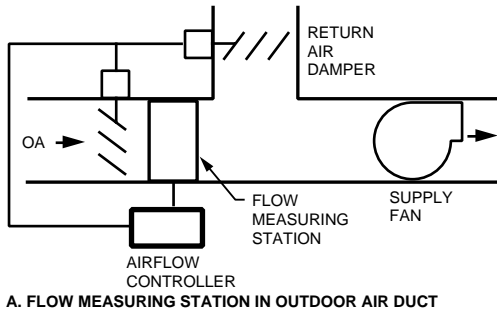
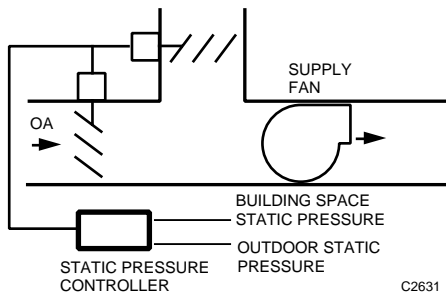

Fig. 35. Return Damper Control Using Airflow Tracking.



If a mixed air control cycle is required, a relief fan may be required. In airflow tracking (Fig. 37), the mixed air controller opens the outdoor air damper above minimum and the relief fan tracks the outdoor air. In direct building static pressure control (Fig. 38) the mixed air controller opens the outdoor air and relief dampers and closes the return damper, causing the relief fan to eliminate excessive pressure.

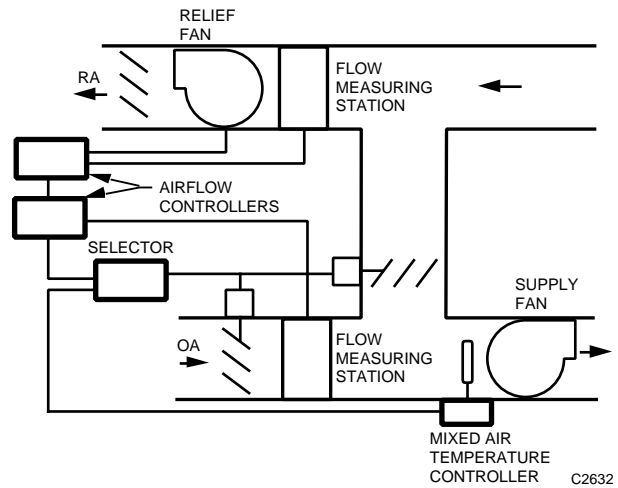

Fig. 37. Mixed Air Control Cycle with Relief Fan Control Using Airflow Tracking.

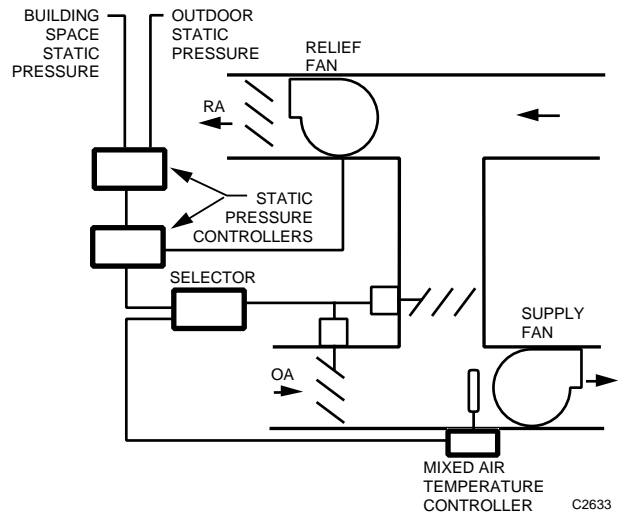

Fig. 38. Mixed Air Control Cycle with Relief Fan Control Using Direct Building Static Pressure.

SEQUENCING FAN CONTROL

VAV systems with multiple fans can use fan sequencing. This allows the fans to operate with greater turndown. For example, if a single fan modulates from 100 percent to 50 percent of wide open capacity (50 percent turndown), then two fans with exactly half the capacity of the larger fan can run with 75 percent turndown. Also, sequencing is more efficient. Most of the year the system is not run at full capacity. Under light load conditions, some fans run while others are at standby. It should be taken into account that fan power varies with the cube of the fan airflow when determining fan staging strategies.

For single supply fan systems, fan output volume is controlled by duct static pressure. However, the decision to turn fans on or off is based on total supply airflow. For centrifugal fans, if Supply Fan 1 in Figure 39 is operating near its maximum velocity capacity, Supply Fan 2 is energized. This opens Damper 2 and Fan 2 is slowly modulated upward. As the duct static is satisfied, Fan 1 will modulate downward until Fan 1 and Fan 2 are operating together, controlled by duct static pressure. If the outputs of Fans 1 and 2 approach maximum capability, Supply Fan 3 is energized. When zone load decreases and terminal units decrease airflow, duct static increases, modulating fans downward. When total supply flow decreases enough, Fan 3 is turned off and Fans 1 and 2 increase in output as required to maintain duct static. Similarly, Fan 2 may be turned off. Time delays protect fan motors from short cycling and fan operation may be alternated to spread wear.

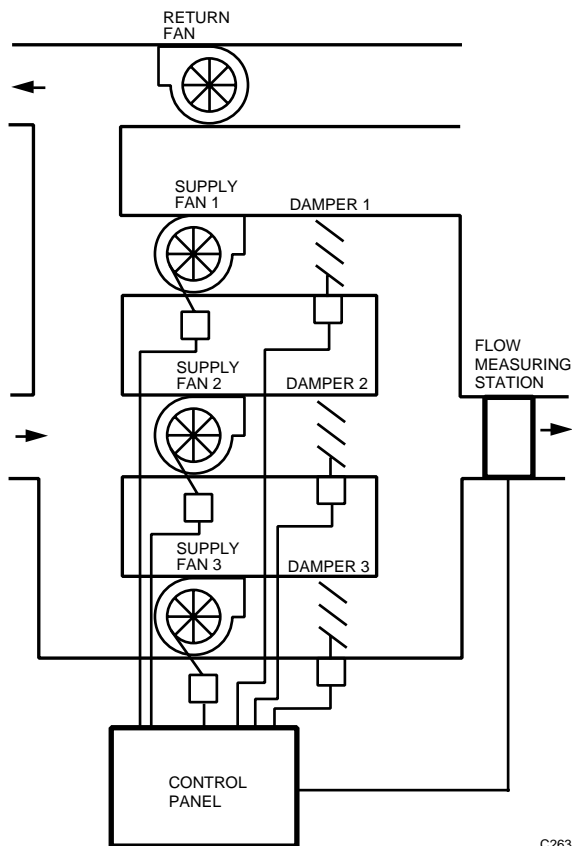

Fig. 39. VAV System with Fan Sequencing.

Vaneaxial fan sequencing is also decided by total supply flow, but the operating fan(s) is modulated to minimum output when the next fan is turned on. This sequence is used to avoid a stall of the starting fan. When all requested fans are running, they are modulated upward to satisfy duct static setpoint.

OTHER CONTROL MODES

Warm-Up Control

If warm-up control is used, it is not necessary to provide outdoor air. The following control actions should be accomplished when using warm-up control:

- Exhaust and relief fans should be off.
- Building pressurization control (if used) should be reset to zero static differential.
- Airflow tracking control (if used) should be reset to zero differential.
- If a return fan is used, the supply fan maximum airflow is limited to no greater than the return fan capacity. With digital control VAV systems, this is accomplished by commanding the VAV boxes to some percent of their maximum airflow setpoints during this mode.
- Space thermostats should change the warm-up mode to normal operation to prevent over or under heating.

Smoke Control

If smoke control is used, the return damper closes and the return fan operates as a relief or exhaust fan. Controls must prevent over pressurization of ducts and spaces.

Night Purge Control

Night purge can be used to cool a building in preparation for occupancy and to cleanse the building of odors, smoke, or other contaminants. Outdoor and relief air dampers must be open and the return damper closed. If airflow tracking is used, supply fan must be limited to the return fan volume. Some control systems allow space thermostats to be set at lower setpoints during this cycle to maximize free cooling. If digital control is used, significant energy savings can be accomplished by commanding all VAV box airflow setpoints to approximately 50 percent of their maximum values.

ZONE AIRFLOW CONTROL

AIRFLOW TRACKING/SPACE STATIC PRESSURE

Zone airflow control provides pressurization control for a portion of a facility. Figure 40 shows a zone airflow control example for a building. Airflow tracking or direct space static pressure control of the return damper on each floor determines the pressurization of each floor.

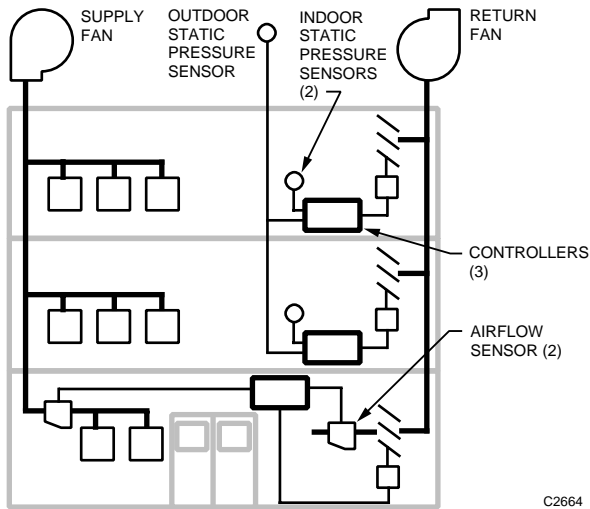

Fig. 40. Control of Return Dampers in Zone Airflow Control.

Airflow tracking is preferred for zone control on the first floor. Direct space static pressure control is difficult to stabilize because of sudden static pressure changes that occur whenever doors open. Also, the leakage around doors would require pressure control at very low setpoints, which are difficult to measure. On upper floors where building permeability is tight, airflow tracking control is not as viable. Direct space static pressure control is preferred for zone control on these floors. Relatively small differences in airflow tracking differentials of tightly sealed zones result in large pressure differentials. Also, all exhaust airflows must be included when dealing with airflow tracking, which makes the control more complex.

Both airflow tracking and direct space static pressure control require accurate sensing. In airflow tracking, the airflow sensors are located in supply and return ducts to sense total airflow. Minimum velocities and location of the airflow sensor relative to any variations from a straight duct are critical considerations. In direct space static pressure control, the indoor static pressure sensor should be in the largest open area and away from doors that open to stairways and elevators. The outdoor static pressure sensor should be at least 5 meters above the building (depending on surrounding conditions) and be specifically designed to accommodate multidirectional winds.

For zone control using airflow tracking or direct space static pressure, return fan control should hold duct pressure constant at a point about two-thirds of the duct length upstream of the return fan (Fig. 41). This control is the same as that used to control the supply fan, except that the duct pressure is negative relative to the ambient surrounding the duct.

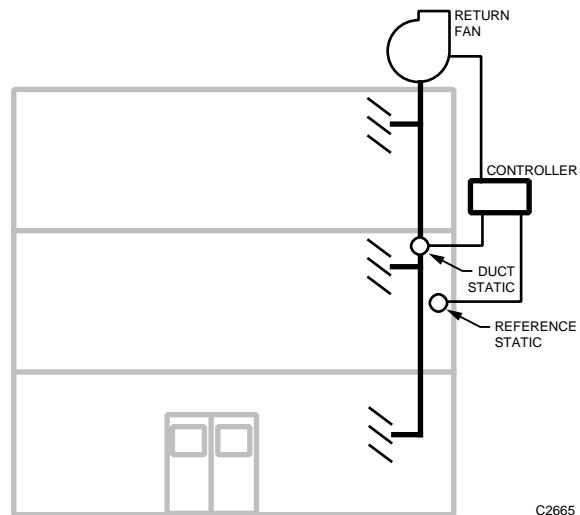

Fig. 41. Control of Return Fan in Zone Airflow Control.

To ensure minimum outdoor airflow, an airflow sensor enables control and provides information on the quantity of outdoor air. The airflow sensor is located in the duct having minimum outdoor airflow (Fig. 42). The control modulates the outdoor air, return air, and exhaust air dampers to provide outdoor air as needed. Normally, the difference between total supply and return airflows, as determined by zone controls, provides the minimum outdoor air. Since each zone is set to provide proper pressurization and buildings which are sealed tightly require less outdoor air for pressurization, this control scheme ensures minimum outdoor air. If minimum outdoor air is increased, it does not affect building pressurization.

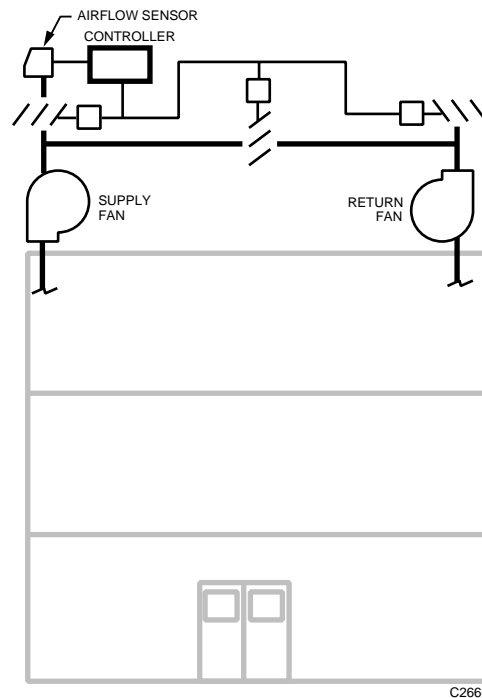

Fig. 42. Minimum Outdoor Air in Zone Airflow Control.

Essentially, the increase of outdoor air above that required to maintain building pressurization is done the same way as mixed air control except outdoor air is controlled by flow rather than mixed air temperature (Fig. 42). In colder climates, overrides must be included to avoid freezing coils.

MULTIPLE FAN SYSTEMS

Multiple fan systems are a form of zone airflow control systems. The same concepts for zone pressurization using airflow tracking or direct space static pressure control apply to multiple fan systems. A return fan is modulated instead of the zone return damper to control zone pressurization.

EXHAUST SYSTEM CONTROL

TYPES

Local exhausts are individual exhaust fan systems used in toilets, kitchens, and other spaces for spot removal of air contaminants. These fans are generally off/on types. They should be controlled or at least monitored from a central location as the exhaust airflow can significantly affect energy efficiency.

General exhausts route contaminants into common ducts which connect to a common exhaust fan. If the airflow is manually balanced, the exhaust fan runs at a fixed level. However, if the airflow is controlled at each entry to vary the airflow in response to the local need, duct pressurization control of the exhaust fan is required. It may also be necessary to introduce outdoor air prior to the general exhaust fan in order to maintain a minimum discharge velocity.

FUME HOODS

Fume hoods are the primary containment devices in most chemical-based research venues. The lab envelope itself becomes the secondary containment barrier. In all cases, the basic use of the fume hood is for the safety of the worker/researcher. Because no air is recirculated to the lab, the fume hood is also the primary user of energy in most labs. The continuing control challenge is to provide the safest possible environment while minimizing operating costs.

There are three types of general purpose fume hoods (Fig. 43): bypass, auxiliary, and standard. Bypass and auxiliary air hoods approximate a constant exhaust airflow rate as the fume hood sash opens and closes. Operation of the standard hood causes the face velocity to increase or decrease with the up and down movement of the sash as a fixed volume of air is exhausted (constant volume).

The bypass hood limits face velocity to about twice the full sash open face velocity which may be acceptable. However, conditioned air is always exhausted making energy savings improbable.

The auxiliary air hood is a bypass type with a supply air diffuser located in front of and above the sash. If the make-up air through the diffuser is not conditioned as well as room air, some minimal energy savings result by employing this type of equipment. However, the performance of this hood is controversial regarding containment of materials in the hood, operator discomfort, and thermal loading of the laboratory. Its use is usually discouraged.

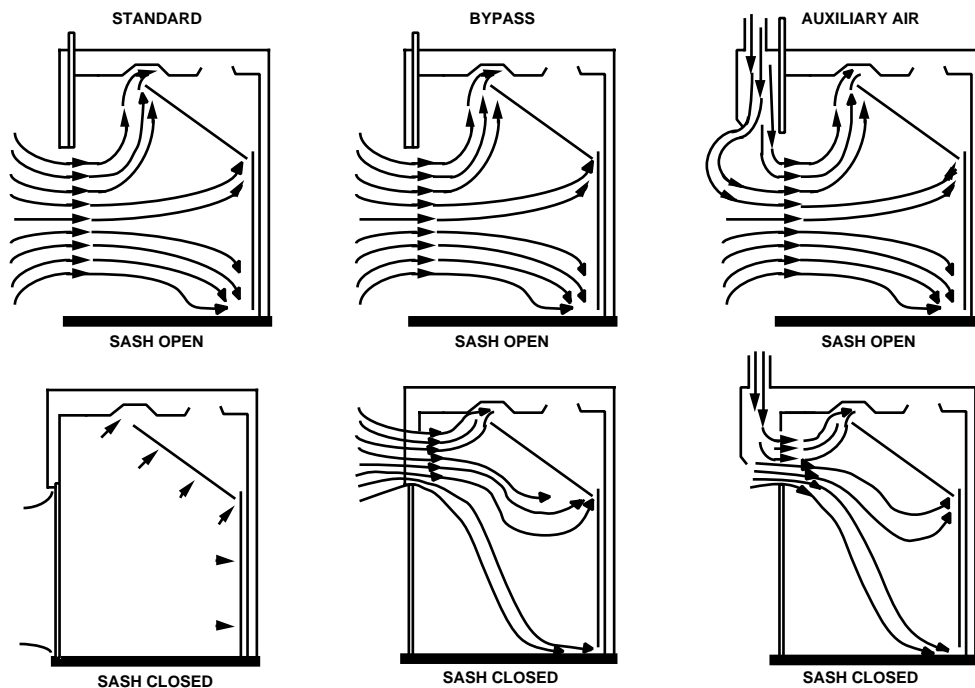

C1484

Fig. 43. General Purpose Fume Hoods.

The standard hood can be controlled either by adding a face velocity sensor at the sash opening or by installing devices to measure the sash opening to calculate face velocity. See Figure 44. This information is then used to modulate a motorized damper, air valve, or variable speed motor to vary exhaust airflow and to maintain a near constant face velocity regardless of sash position. Since the hood removes non-recirculated, conditioned air from the space, significant energy savings can be realized by adding these controls to vary air volume and minimize the rate of exhaust. The other common method used to moderate energy usage is to provide two-position controls which control all hoods at one constant volume rate during occupied periods and a reduced constant volume when the lab is unoccupied. New technologies now available allow the air flow in individual fumehoods to be reduced when sensors determine no one is present at the face of the hood.

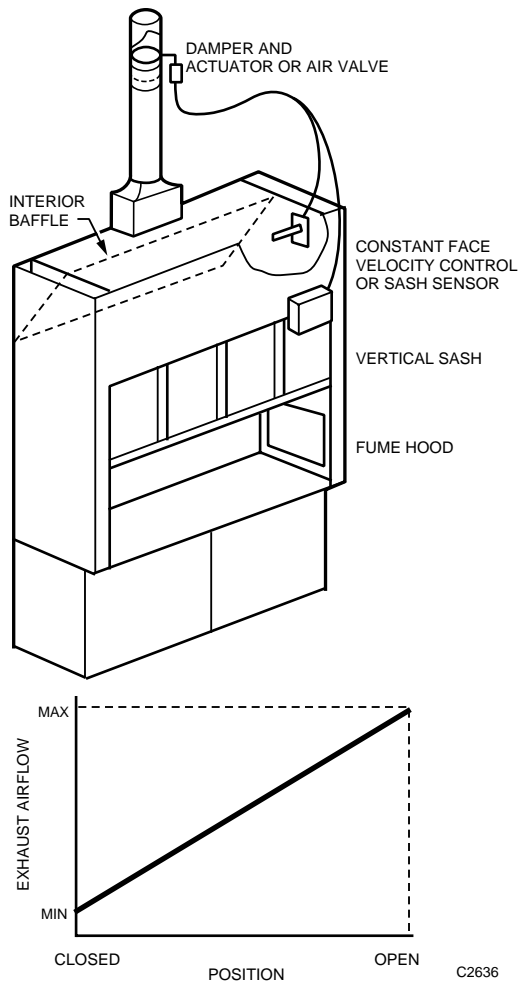

Fig. 44. Variable Exhaust, Constant Face Velocity Fume Hood.

The subject of the “correct” face velocity is still debated. However, most research now indicates that 0.4 to 0.5 meters per second (m/s) at the sash opening provides a zone of maximum containment and operating efficiency provided that the supply air delivery system is designed to minimize cross drafts. Velocities lower than this challenge the containment properties of the hood, and without specialized lab design and training in lab safety protocols, can create unsafe working conditions. Velocities higher than 0.6 m/s can cause excessive turbulence within the hood which not only compromise its containment properties but contributes to excessive energy usage.

Figure 45 illustrates a face velocity chart showing the comparative face velocities which may be experienced with different types of hoods using either constant volume or variable volume control strategies. The variable volume hood with face velocity controls in this example shows increased air velocities at the low aspect of sash closure because, in most cases, a minimum air volume is required to be continuously exhausted from the fume hood.

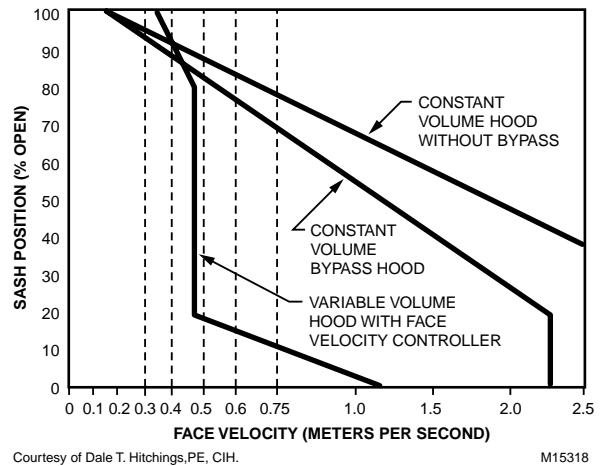

Fig. 45. Comparative Fume Hood Face Velocities.

LABORATORY PRESSURIZATION

Constant supply airflow often is not capable of constant space pressurization in research laboratories because of the use of constant face velocity fume hoods and the use of other variable exhausts. To accomplish containment and prevent excessive pressurization requires some form of volumetric air flow control (air flow tracking) or control of differential pressure within the lab space (direct pressure control).

Airflow tracking (Fig. 46) measures all exhaust and supply airflows and maintains a relationship between the total exhaust and total supply. For space pressurization to be negative relative to adjacent spaces, the total exhaust must exceed the total supply. The difference between exhaust and supply airflows (offset) should be a fixed quantity for an particular space to keep the pressurization constant. A constant percentage offset value is sometimes used.

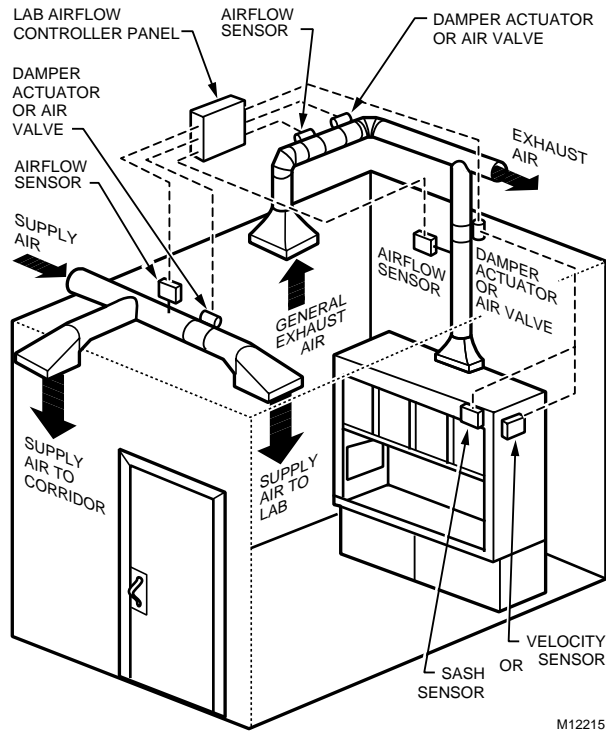

Fig. 46. Airflow Tracking Control.

Airflow sensors located in all supply and exhaust ducts provide flow signals which can be compared by a controller. Sensor locations must meet the manufacturers minimum installation guidelines, such as velocity range and length of straight duct before and after the sensor, to ensure accuracy. Materials and finishes for sensors in exhaust ducts exposed to corrosive fumes must be carefully selected.

If future flexibility and changing lab configurations are important considerations, then flow sensor location, duct size, supply airflow rate, and control system design should all include capability to be modified in the future.

A characteristic of airflow tracking is stability of the system in the face of breaches to the lab envelope. This is most often lab door openings. In a laboratory maintained at a negative pressure, the space static pressure increases and the air velocity through all openings drops significantly when a door opens. Figure 47 shows a laboratory example with a single fume hood, a single door 1m wide x 2m high (2m²), and a crack area estimated at 0.05 m². If the fixed airflow tracking differential is 0.1 m³/s, the average velocity through the cracks would be 2.0 m/s which is more than adequate for containment. However, when the door opens, the average velocity in this example decreases to 0.05 m/s which is marginal to inadequate for containment.

However, the ability of the tracking system to quickly (usually within several seconds) react and compensate for door openings and other breaches is a positive characteristic of this control method.

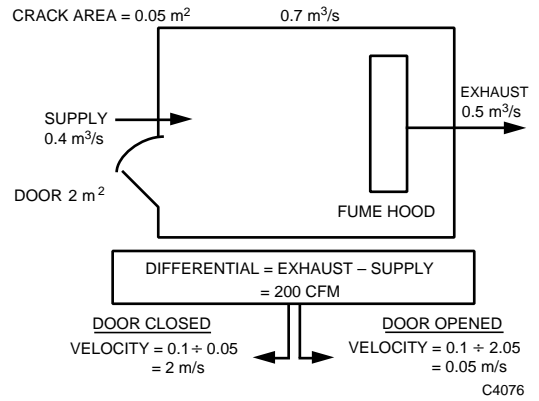

Fig. 47. Airflow Tracking Example with Door Closed and Opened.

Supply duct pressure and building pressurization control are simpler and more stable with airflow tracking because they are less affected by this type of unexpected upset. The supply duct pressure control remains stable due to fewer disruptions. Building pressurization, defined as the difference between total air leaving the building and the total air entering, remains the same.

Direct pressure control (Fig. 48) provides the same control function as airflow tracking but its characteristics are quite different. Direct space pressurization control senses the differential pressure between the space being controlled and a reference space which is usually an adjacent space or hallway.

Figure 49 shows a similar example of negative space pressurization utilizing direct pressure control. If the airflow through the hood is 0.5 m³/s and the pressure control reduces the supply airflow when the door is opened, the average velocity through openings drops from 2.0 m/s to 0.25 m/s.

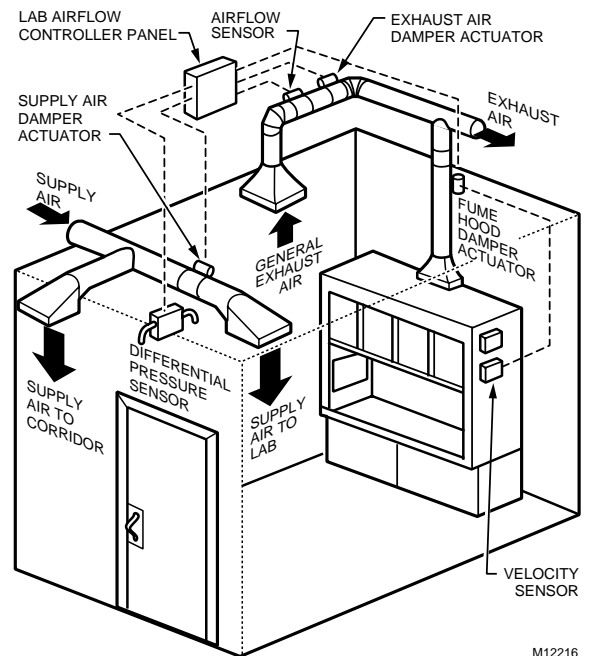

Fig. 48. Direct Pressure Control.

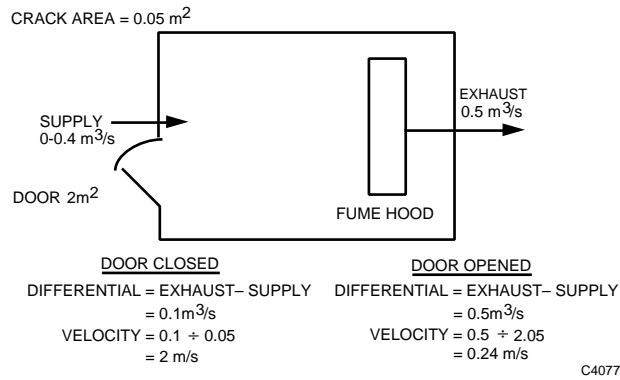

Fig. 49. Direct Space Pressure Control Example with Door Closed and Open.

When a door is opened, the space pressure control responds by reducing the supply airflow to zero and/or increasing general exhaust flow. Replacement air for the space that is being exhausted migrates from adjacent areas through the doorway and cracks. The supply system for the adjacent area must replace this air in order to maintain a positive building pressurization.

The significant issues are 1) how fast can the room pressurization system respond to upset (a door opening or several hoods being closed at once) and 2) what is the impact on adjacent areas and the rest of the building. Because of the inherent lag of direct pressure control systems (the time it takes the differential pressure sensor to know that several hoods have been closed) the lab can go into a positive pressure mode for a short period of time. Further, with extended door openings and other breaches it is possible for a direct pressure based system to call for amounts of exhaust air which may be drawn excessively from the adjacent spaces. This has the potential for cascading air flow and pressure effects throughout the building.

For reasons of speed and stability, volumetric tracking control is becoming the more accepted method of pressurization control in lab spaces.

Direct pressure control remains a viable alternative, especially in lab spaces that are sealed tightly, where there is sufficient building supply air and good lab operation protocols.

REFERENCES

The following references were useful in preparing this section on Building Airflow System Control Applications. Selected material was included from:

Design of Smoke Control Systems for Buildings
ISBN 0-910110-03-4

ASHRAE Handbooks—1995 Applications and 1996 HVAC Systems and Equipment
American Society of Heating, Refrigerating and Air Conditioning Engineers, Inc.
1791 Tullie Circle, N. E.
Atlanta, GA 30329

Trane Air Conditioning Manual
The Trane Company
Educational Department
3600 Pammel Creek Road
LaCrosse, WI 54601

Engineering Fundamentals of Fans and Roof Ventilators
Plant Engineering Library
Technical Publishing*
1301 S. Grove Avenue
P. O. Box 1030
Barrington, IL 60010

Industrial Ventilation Manual
Committee on Industrial Ventilation
P. O. Box 16153
Lansing, MI 48901

Modern Development In Fluid Dynamics
Dover Publications Inc.
180 Variek Street
New York, NY 10014

* A Division of Dun-Donnelley Publishing Corp., a Company of the Dun & Bradstreet Corporation.

Chiller, Boiler, and Distribution System Control Applications

ENGINEERING MANUAL OF AUTOMATIC CONTROL

CONTENTS

Introduction	295
Abbreviations	295
Definitions	295
Symbols	296
Chiller System Control	297
Introduction	297
Vapor-Compression Refrigeration	297
Vapor-Compression Cycle	297
Centrifugal Compressor	298
Reciprocating Compressor	299
Screw Compressor	299
Absorption Refrigeration	299
Absorption Cycle	299
Absorption Chiller	300
Chiller Control Requirements	301
Basic Chiller Control	301
System Controls Which Influence the Chiller	301
Safety Controls	301
Chiller/BMCS Interface	301
Chilled Water Systems	302
Central Cooling Plants	302
Single Centrifugal Chiller Control	302
Single Centrifugal Chiller Control Application	303
Multiple Chiller System Control Applications	305
Dual Centrifugal Chillers Control Application	307
Similar Multiple Centrifugal Chillers Control Applications	309
Equal Sized Centrifugal Chillers Control	309
Multiple Centrifugal Chiller Sequencing	311
Dissimilar Multiple Centrifugal Chillers Control	313
Alternative Multiple Decoupled Chiller Control	313
Combination Absorption and Centrifugal Chiller System Control	313
Chiller Pump Optimization	314
Thermal Storage Control	315
General	315
Control Modes	315
Cooling Tower and Condenser Water Control	316
Cooling Tower Performance Characteristics	316
Cooling Tower Capacity Control	316
On-Off Cooling Tower Fan Control	317
Two-Speed Cooling Tower Fan Control	317
Variable Speed Cooling Tower Fan Control	318
Single Cooling Tower Variable Speed Fan Control	318
Dual Cooling Tower Variable Speed Fan Control	320
Chiller Heat Recovery System	323
Free Cooling-Tower Cooling	323
Tower Free Cooling, Dual Chillers	325

Boiler System Control	327
Introduction	327
Boiler Types	327
Cast Iron and Steel Boilers	327
Modular Boilers	327
Electric Boilers	328
Boiler Ratings and Efficiency	328
Combustion in Boilers	329
Principles of Combustion	329
Flue Gas Analysis	329
Oil Burners	329
Gas Burners	329
Boiler Controls	330
Boiler Output Control	330
Combustion Control	330
Flame Safeguard Control	330
Flame Safeguard Instrumentation	331
Application of Boiler Controls	331
Multiple Boiler Systems	332
General	332
Dual Boiler Plant Control	333
Modular Boilers	335
Hot and Chilled Water Distribution Systems Control	335
Introduction	335
Classification of Water Distribution Systems	335
Typical Water Distribution System	335
Control Requirements for Water Distribution Systems	336
Centrifugal Pumps Used in Hot and Chilled Water Systems	336
Pump Performance	337
Pump Power Requirements	338
Pump Performance Curves	338
Pump Efficiency	338
Pump Affinity Laws	339
Matching Pumps to Water Distribution Systems	340
System Curves	340
Plotting a System Curve	340
Combining System and Pump Curves	340
Variable Speed Pumps	342
Pumps Applied to Open Systems	343
Multiple Pumps	343
Operation	344
Dual Pump Curves	345
Distribution System Fundamentals	345
Direct Vs Reverse Return Piping Systems	346
Coupled Vs Decoupled Piping Systems	347
Methods of Controlling Distribution Systems	348
Three-Way Coil Bypass and Two-Way Valve Control	348
Valve Selection Factors	348
Flow and Pressure Control Solutions	348
Single Pump, Pressure Bypass, Direct Return	349
Valve Location and Sizing	349
Differential Pressure Sensor Location	349
Single Pump, Pressure Bypass, Reverse Return	351
Dual Pumps, Dual Chillers, Pressure Bypass, 90 percent Chiller Flow, Direct Return	352
AHU Valve High Differential Pressure Control	352

Variable Speed Pump Control	353
Decoupled Variable Speed Pump Control, Direct Return	353
Pump Speed Valve Position Load Reset	355
Balancing Valve Considerations	357
Balancing Valve Effects	357
Balancing Valve Elimination	357
Differential Pressure Sensor Location Summary	357
Pump Minimum Flow Control	357
Decoupled Variable Speed Pump Control, Reverse Return	358
Hot Water Distribution Systems	358
General	358
Hot Water Converters	358
Hot Water Piping Arrangements	359
General	359
Primary-Secondary Pumping	360
Control of Hot Water Systems	360
General	360
Modulating Flow Control	360
Supply Hot Water Temperature Control	361
Supply Hot Water Temperature Control with Flow Control	361
Hot Water Reset	361
Hot Water Converter	361
Three-Way Valve	364
Coordinating Valve Selection and System Design	364
Hot Water Control Method Selection	364
Chilled Water Distribution Systems	364
General	364
System Objectives	365
Control of Terminal Units	365
Dual Temperature Systems	365
Changeover Precautions	365
Multiple-Zone Dual-Temperature Systems	365
Steam Distribution Systems and Control	366
Introduction	366
Advantages of Steam Systems Vs Hot Water Systems	366
Steam System Objectives	366
Properties of Steam	366
Steam System Heat Characteristics	367
Steam Pressure, Temperature, and Density	367
Steam Quality	367
Steam Distribution Systems	368
Steam Piping Mains	368
Steam Traps	368
Pressure Reducing Valve Station	369
Types of Low Pressure Steam Distribution Systems	370
One-Pipe Steam Systems	370
Two-Pipe Steam Systems	370
Types of Condensate Return Systems	370
Variable Vacuum Return Systems	371
Control Principles for Steam Heating Devices	371
General	371
Modulating Steam Coil Performance	371
Oversized Valve	372
Correctly Sized Valve	372
Supply and Return Main Pressures	373
System Design Considerations for Steam Coils	373
Low Temperature Protection for Steam Coils	373

High Temperature Water Heating System Control	374
Introduction	374
High Temperature Water (HTW) Heating	374
High Temperature Water Safety	375
HTW Control Selection	375
HTW Valve Selection	375
Valve Style	375
Valve Body Materials	375
Valve Trim	376
Valve Packing	376
Valve Flow Characteristics	376
Actuators	376
Valve Size	376
Valve Location	376
Instantaneous Converter Control	376
HTW Coils	377
HTW Space Heating Units	378
Storage Converters	378
Multizone Space-Heating HTW Water Converters	378
HTW Steam Generators	379
 District Heating Applications	 380
Introduction	380
Heat Sources	380
The Distribution Network	380
The Substation	381
Abbreviations	381
Definitions	381
Symbols	382
System Configuration	382
Heat Generation	382
Heat Distribution Network	382
Hot Water System Control	382
Steam System Vs Hot Water System	383
Hot Water Pipeline System	383
Booster Pump Station	383
Pressure Reducing Stations	383
Mixing Station	383
Key Points	384
Heat Transfer Substations	384
Direct Heat Transfer Substations	384
Indirect Heat Transfer Substations	385
Hybrid Heat Transfer Substations	386
Control Applications	387
DDC Control of High Performance Substation	387
DDC Control of a Small House Substation	389
Control of Apartment Building Substations with Domestic Hot Water	390
Hybrid Building Substation	393

INTRODUCTION

This section provides descriptions of and control information about water chillers, cooling towers, hot water boilers, steam boilers, and water, steam, and district heating distribution systems. It discusses various methods of controlling and distributing steam or water to heating and cooling coils, and methods of ensuring safe and proper control of boilers, chillers, and converters. Sample system solutions are based upon digital control systems and networks. These digital control strategies may not be practical with other forms of control, and may not be possible with all

digital controllers or by all digital controller programmers. Many solutions are portrayed as they may be specified to be displayed on a PC based BMCS color graphic monitor. The data points shown on the color graphics are still recommended for systems without color graphics, and may be specified via a points list or by publishing the graphic picture. The values (setpoints, timings, parameters, etc.) shown in the examples are arbitrary. Values for any given project must be specific to the project.

ABBREVIATIONS

AHU	— Air Handling Unit		
BMCS	— A Building Management and Control System, including digital controllers and communication networks.		and user defined start-up ramp time. See CONTROL FUNDAMENTALS section.
CHW	— Chilled Water	HW	— Hot Water
DB	— Dry Bulb	HX	— Heat exchanger
DP	— Differential Pressure	OA	— Outside air
Delta T (ΔT)	— Differential Temperature	PID	— Proportional-Integral-Derivative
EPID	— Enhanced PID. A PID algorithm which includes integral component wind-up prevention, user defined initial value,	SG	— Specific Gravity
		VAV	— Variable Air Volume
		VSD	— Variable Speed Drive
		WB	— Wet Bulb

DEFINITIONS

Approach:

1. The temperature difference, in a cooling tower, between outdoor wet bulb and condenser water leaving the tower.
2. The temperature difference in an air cooled condenser between the liquid refrigerant leaving the condenser and the entering air dry bulb.
3. The temperature difference in a conduction heat exchanger between the entering working fluid and the leaving treated fluid.

Central plant: An area or building where the chillers and boilers for a building or group of buildings are located.

Compressor: A mechanical device for increasing a gas pressure.

- **Centrifugal compressor:** A device which uses centrifugal force to compress refrigerant vapors in a vapor-compression cycle chiller. This is not a positive displacement compressor.
- **Positive displacement compressor:** A compressor that reduces the volume of a compression chamber to compress a gas.
- **Reciprocating compressor:** A positive displacement compressor which uses the reciprocating motion of one or more pistons to compress a gas.

- **Screw compressor:** A positive displacement compressor which uses the rotary motion of two meshed helical rotors to compress a gas.

Constant speed pumping: A pumping system where the system pressure is maintained by a constant speed pump.

Deadband: A range of the controlled variable in which no corrective action is taken by the system and no energy is used.

Diversity: A design method where building elements (such as chillers and pumps) are sized for the instantaneous building peak load requirements (rather than the sum of all the loads, which may individually peak at times other than when the building peaks). Diversity does not allow the use of three-way AHU control valves.

Double bundle Condenser: A chiller condenser having two coils in the shell to allow the chiller to dissipate heat either to the cooling tower or to a heating load.

Non-symmetrical loading: Diversity in multiple load systems, where individual loads operate at different times or loading from the others.

Primary Thermal Units: Thermal production water elements such as chillers and boilers. Thermal production air elements such as air handlers.

Rangeability: The ratio of maximum to minimum flow of a valve within which the deviation from the inherent flow characteristic does not exceed some stated limits.

Refrigerant pressure: The pressure difference between compressor suction and discharge pressures or the temperature difference between condensing and evaporating temperatures.

Secondary Thermal Units: Thermal consumption water elements such as AHU coils. Thermal consumption air elements such as VAV boxes.

Superheat: The additional heat contained in a vapor at a temperature higher than the saturation (boiling) temperature corresponding to the pressure of the vapor.

Surge: A condition where refrigerant reverses flow approximately every two seconds creating excessive noise, vibration, and heat. Surge is caused by insufficient pumping pressure to meet the rise in pressure from evaporator to condenser.

Symmetrical loading: Diversity in multiple load systems, where individual loads operate at the same time and same percentage loading as the others.

Variable speed pumping (VSP): A pumping system where the flow/pressure is varied by changing the pump speed. Diversity factor = 1.

SYMBOLS

The following symbols are used in the system schematics following. These symbols denote the nature of the device, such as a thermometer for temperature sensing.

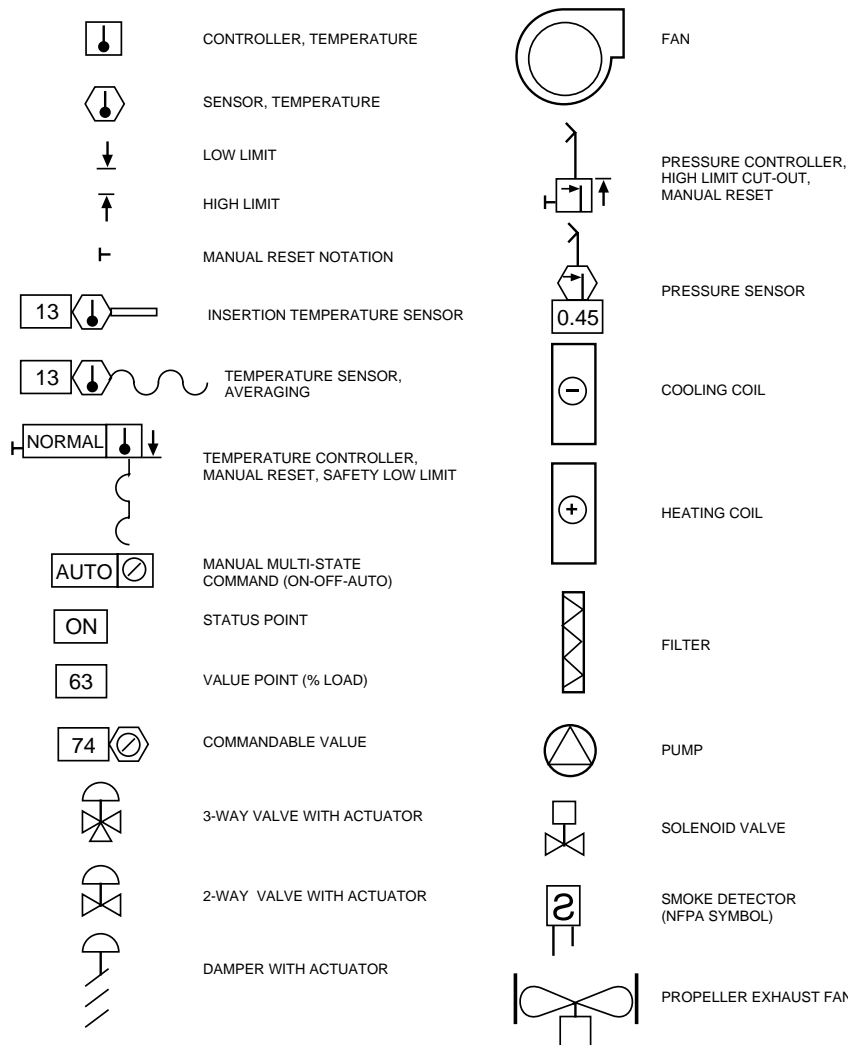

M15150

CHILLER SYSTEM CONTROL

INTRODUCTION

A chilled water system consists of a refrigeration system (water chiller), a chilled water distribution system, loads cooled by the chilled water and a means of dissipating the heat collected by the system. The refrigeration system cools water pumped through it by a chilled water pump. The chilled water flows through the distribution system to coils in air handling units or terminal units. Heat is removed from the refrigeration system using water or air. For chilled water control within AHU systems, see the Air Handling System Control Applications section.

Chilled water systems are used in many buildings for cooling because of their flexibility and operating cost compared with direct expansion (DX) cooling coil systems. Typically chilled water is generated at a central location by one or more chillers and distributed to coils in air handling system (Fig. 1). The quantity and temperature of the water supplied must be sufficient to meet the needs of all fan systems. Since the chilled water system is the major user of energy in many buildings, energy costs should be a consideration in chilled water plant configuration.

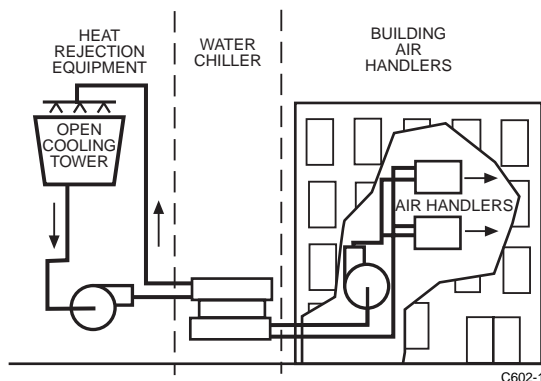

Fig. 1. Typical Water Chilling System.

A chilled water system can provide hot water for a heating load when a simultaneous heating and cooling load exists. It can be used with a chilled water, ice tank, or phase change material thermal storage system to lower the peak load demand and allow use of a smaller chiller. It can use the system cooling tower during light load conditions to supply cool water to the system without running the chiller, if the outside air (OA) WB temperature is low enough.

Chiller capacity controls are usually factory installed by the chiller manufacturer. The BMCS usually stages chillers on and off, provides chiller controls with a chilled water temperature setpoint, and controls the condenser water system. Chillers are usually controlled from their leaving water temperature; except that chillers using reciprocating compressors are often controlled from their entering water temperature, since staging and loading in steps causes steps in the leaving water temperature.

Chiller types are classified by type of refrigeration cycle: vapor-compression or absorption. In addition, those using the vapor-compression cycle are referred to by the type of compressor: centrifugal or positive displacement. A positive displacement compressor can be either reciprocating or screw for this discussion. See related ASHRAE and chiller manufacturers manuals for detailed information of chiller cycles.

VAPOR-COMPRESSION REFRIGERATION

VAPOR-COMPRESSION CYCLE

The vapor-compression cycle is the most common type of refrigeration system. When the compressor (Fig. 2) starts, the increased pressure on the high side and the decreased pressure on the low side causes liquid refrigerant to flow from the receiver to the expansion valve. The expansion valve is a restriction in the liquid line which meters the refrigerant into the evaporator. It establishes a boundary between the low (pressure) side, including the evaporator and the high (pressure) side, including the condenser and the receiver. The compressor is the other boundary. The liquid refrigerant in the evaporator boils as it absorbs heat from the chilled water. The refrigerant leaves the evaporator and enters the compressor as a cold low-pressure gas. The refrigerant leaves the compressor as a hot high-pressure gas and passes through the condenser where it is cooled by the condenser water until it condenses and returns to the receiver as a liquid. The cycle is the same regardless of the compressor type or refrigerant used.

Two common types of expansion valves are constant pressure and thermostatic. The constant pressure valve is suitable only when the load is constant. It is essentially a pressure regulator which maintains a constant pressure in the evaporator.

The thermostatic expansion valve is used for varying cooling loads, such as those found in HVAC systems. It has a remote temperature sensing element which is usually installed on the suction line between the evaporator and the compressor. It is set to adjust the expansion valve so there is a small amount of superheat in the suction line refrigerant. Superheat means that all of the liquid has evaporated and the vapor has been heated above the evaporation temperature by the water or air being cooled. This prevents liquid from entering the compressor.

A flooded shell and tube chiller evaporator (Fig. 3) is usually used with centrifugal compressors while, a direct expansion chiller evaporator (Fig. 4) is used with positive displacement compressors. In both cases the condenser is a large pressure cylinder (shell) with tubes connected to inlet and outlet headers. In the flooded shell and tube type evaporator, the shell is about 80 percent filled with refrigerant and the chilled water flows through the tubes. Heat from the water evaporates the refrigerant surrounding the tubes which cools the water. The refrigerant vapor rises to the top of the shell and into the refrigerant suction line.

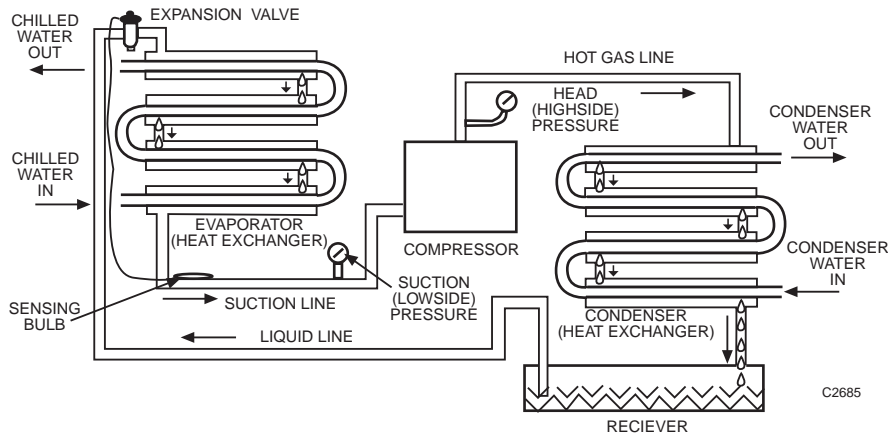

Fig. 2. Typical Vapor-Compression Cycle Water Chiller.

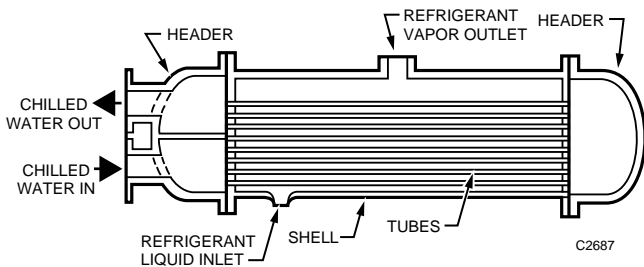

Fig. 3. Flooded Shell and Tube Chiller Evaporator.

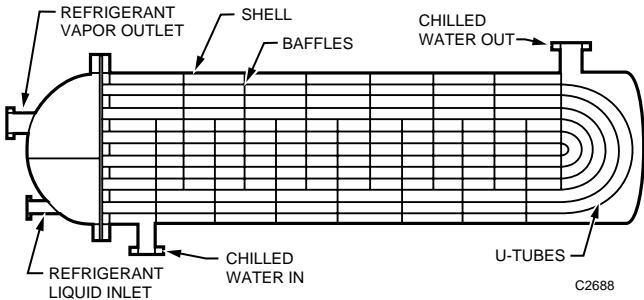

Fig. 4. Direct Expansion Chiller Evaporator.

The direct expansion chiller evaporator is the reverse of the flooded shell and tube chiller evaporator, water in the shell and the refrigerant in the tubes.

The compressor can be reciprocating, centrifugal, or screw type. The centrifugal and screw types are generally found on the larger systems.

The chiller condenser is usually water cooled but may be air cooled or evaporative cooled. The most common water cooled condenser is the shell and tube type (similar to Figure 3). The cooling (condenser) water flows through the tubes and the refrigerant vapor condenses on the cool tube surface and drops to the bottom of the shell where it flows into the liquid line to the receiver or evaporator.

An air cooled condenser is a series of finned tubes (coils) through which the refrigerant vapor flows. Air is blown over the coils to cool and condense the refrigerant vapor.

An evaporative condenser is similar to the air cooled condenser where the refrigerant flows through a coil. Water is sprayed over the coil and then air is blown over the coil to evaporate the water and condense the refrigerant. Evaporative condensers are rarely used because of the additional maintenance compared with an air cooled condenser.

CENTRIFUGAL COMPRESSOR

Centrifugal compressors are available in a wide range of sizes. Compressor capacity can be modulated from maximum to relatively low values. Centrifugal chiller systems can be designed to meet a wide range of chilled liquid (evaporator) and cooling fluid (condenser) temperatures.

Operation of the compressor is similar to a centrifugal fan or pump. Gaseous refrigerant enters the inlet (Fig. 5) and passes through inlet vanes into the chambers or blades radiating from the center of the impeller. The impeller, rotating at a high rate of speed, throws the gas to the outer circumference of the impeller by centrifugal force. This increases the velocity and pressure of the gas. The gas is then thrown from the impeller into the volute where most of the velocity (kinetic energy) is converted to pressure.

Use of a larger evaporator and condenser decreases the energy needed by the compressor for a given cooling load. Typical single stage high speed compressor construction is shown in Figure 5. The prerotation vanes (inlet guide vanes), located in the suction side of the compressor, control the gaseous refrigerant flow by restricting flow. As the vanes vary the flow, the compressor pumping capacity varies. In the open position the vanes give a rotating motion to the refrigerant in a direction opposite to the impeller rotation. This allows the chambers or blades to pick up a larger amount of gas.

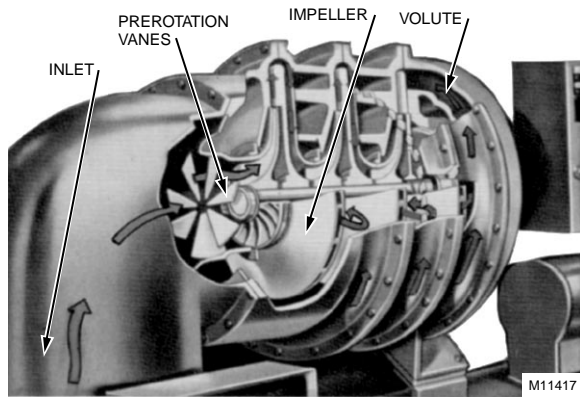

Reprinted by permission: The Trane Company,
LaCrosse, WI 54601

Fig. 5. Cutaway of Single Stage Centrifugal Compressor.

Centrifugal compressors are driven by turbines, electric motors, or internal combustion engines. Inlet vane control or speed control varies the capacity. Each method has different performance characteristics. A combination of speed and inlet vane control provides the highest operating efficiency. Multiple stage direct drive type compressors are available in many configurations.

Refrigerant pressure is the pressure difference between the compressor inlet and outlet and is the primary factor affecting chiller efficiency. For a given load, reducing refrigerant pressure improves efficiency. Evaporation and condensation temperatures establish these pressures and are determined by chilled water temperature and condenser water temperature. Refrigerant pressure is reduced by the following:

- Reducing condenser water temperature.
- Raising chilled water temperature.
- Reducing load.
- Decreasing design differential temperature of evaporator and condenser heat exchangers by increasing the size of the heat exchangers.

The load for maximum chiller efficiency varies with chillers and chiller manufacturers. It is often 70 to 80 percent, but can be 100 percent.

RECIPROCATING COMPRESSOR

The reciprocating compressor is a positive displacement device consisting of several cylinders and piston. The crankshaft is driven by a motor or engine. Spring loaded valves allow low pressure refrigerant vapor to enter the cylinder on the downstroke and high pressure refrigerant vapor to exit on the upstroke. Because the compressor is a positive displacement device its capacity is not greatly influenced by refrigerant pressure. However, power required per unit of cooling is directly related to refrigerant pressure. Keeping condenser temperature as low as possible also reduces energy requirements, therefore, compressors with water cooled condensers use less power than air cooled condensers. However, condenser water temperature must not be allowed to go too low or there will not be enough pressure difference to circulate the refrigerant.

Reciprocating chiller capacity is controlled in stages (steps). Methods of capacity control include the following:

- Unloading cylinders
- On-off cycling of multiple compressors
- Hot-gas bypass
- Hot-gas through evaporator

Cylinder unloading or multiple compressor on-off cycling is sequenced by automatic controls. The cylinder inlet valves are held open so no compression takes place during cylinder unloading. Capacity control mechanisms and controls are usually packaged with the chiller. Step capacity control of refrigeration must provide a compromise between frequent cycling and wide temperature swings. Use of chilled water return temperature as controlling variable lengthens the compressor on and off cycles. When cylinder unloading is used, the minimum of time after the compressor is cycled off on low load, is normally less than for multiple compressors. Off time is critical because the refrigeration system must have time to equalize the pressure between high and low sides so that the starting load will not be too great for the motor.

SCREW COMPRESSOR

A screw compressor is a positive displacement device which uses two meshed helical rotors to provide compression. It is also known as a helical rotary compressor. Basic construction of a helical rotary twin screw compressor is shown in Figure 6. The capacity of a screw compressor can be modulated by speed control or a sliding valve that varies the length of compression area of the helical screws and bypasses some gas back to the inlet of the compressor.

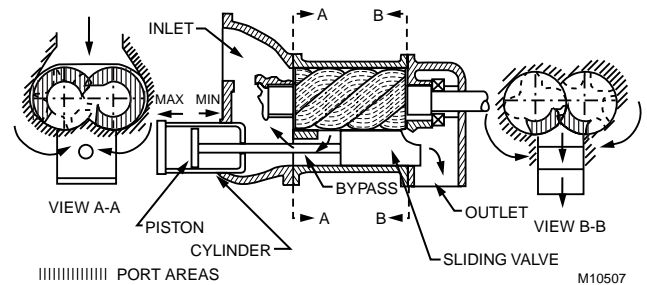

Fig. 6. Helical Rotary Twin Screw Compressor.

ABSORPTION REFRIGERATION

ABSORPTION CYCLE

The absorption cycle uses a fluid called an absorbent to absorb evaporated refrigerant vapor in an “absorber” section. The resulting combination of fluid and refrigerant is moved into a “generator” section where heat is used to evaporate the refrigerant from the absorbent.

In the absorber (Fig. 7) the absorbent, also called strong absorbent at this point, assimilates the refrigerant vapor when sprayed through it. The resulting weak absorbent is pumped by the generator pump through the heat exchanger, where it picks up some of the heat of the strong absorbent, then into the

generator. In the generator the weak absorbent is heated to drive (evaporate) the refrigerant out of the absorbent and restore the strong absorbent. The strong absorbent then passes through the heat exchanger, where it gives up some heat to the weak absorbent, and then returns to the spray heads in the absorber completing the cycle for the absorbent.

NOTE: Industry standards reverse the definitions of strong absorbent and weak absorbent when ammonia is the refrigerant and water the absorbent.

The refrigerant vapor migrates from the generator to the condenser where it is cooled until it condenses to a liquid. The liquid refrigerant flows to the evaporator where the refrigerant pump sprays the liquid over the chilled water coils. The heat from the chilled water evaporates the liquid. The resulting vapor migrates to the absorber where it is absorbed by the strong absorbent and pumped to the generator to complete the refrigerant cycle.

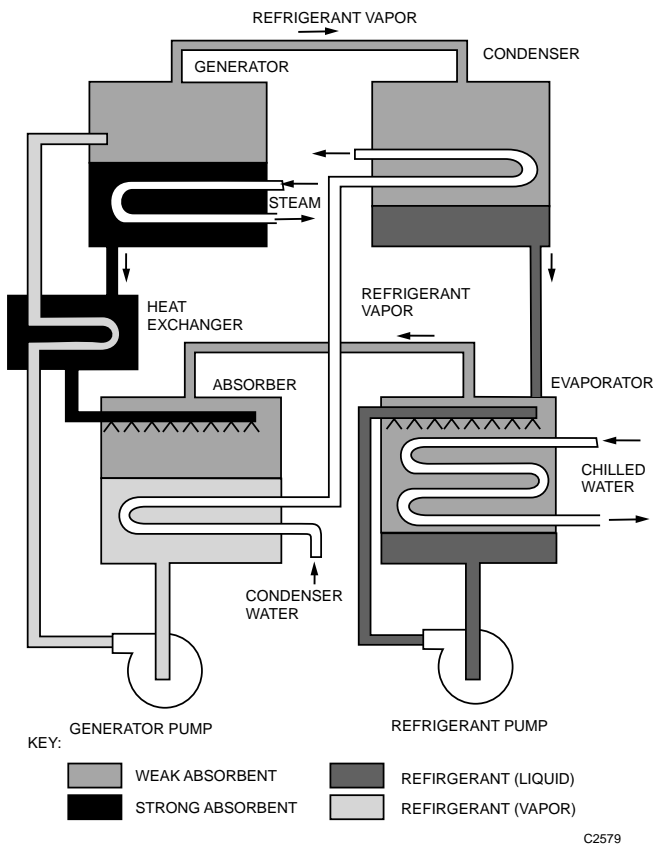
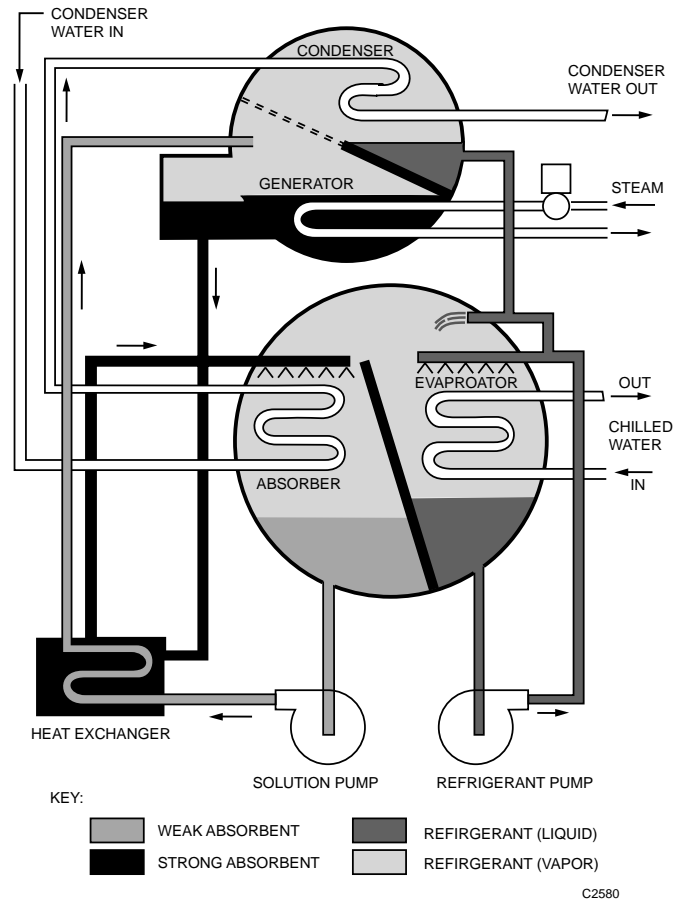

Fig. 7. Absorption Chiller Operating Cycle Schematic.

Figure 8 is a typical water-lithium bromide absorption cycle chiller. Lithium bromide is the absorbent and water is the refrigerant. Use of water as a refrigerant requires that the system be sealed, all the air removed, and an absolute pressure of 0.847 kPa be maintained. Under these conditions the refrigerant (water) boils at 4.5°C which allows the refrigerant to cool the chilled water to 6.5°C.



Reprinted by permission from the ASHRAE Handbook-1994 Refrigeration

Fig. 8. Diagram of Two-Shell Lithium Bromide Cycle Water Chiller.

ABSORPTION CHILLER

Capacity control of a water-lithium bromide absorption chiller is modulated by changing the concentration of the strong absorbent by varying the heat input to the process in the generator, controlling condenser water flow, or controlling flow of the strong absorbent. Heat sources may be hot water, high temperature hot water, steam, or a gas flame (direct fired). Light loads require a reduced concentration of strong absorbent (absorbent retains more refrigerant) or less flow of the strong absorbent. The amount of heat required for a given cooling load is proportional to the temperature difference between condensing water and chilled water (refrigerant pressure). It is also proportional to temperature lift (chilled water temperature difference).

Some absorption chillers require the condensing water be kept constant at the design temperature. To improve seasonal operating efficiency some designs accept condensing water temperatures below design down to 7°C. This requires an

internal control that transfers liquid from refrigerant circuit to absorbent circuit, transfers liquid from absorbent circuit to refrigerant circuit, limits heat input, or a combination. Low condenser water temperature decreases energy usage and increases unit capacity.

When the condenser water temperature is too low, the absorbent contains too much refrigerant and the solution crystallizes. A safety control used by some absorption units senses when the lithium bromide concentration is getting too high with a low cooling water temperature and takes action to avoid crystallization.

Absorption chillers are normally used where heat energy is available at very low cost such as the exhaust from a steam turbine. They also are used to reduce electric load and therefore peak electric demand.

CHILLER CONTROL REQUIREMENTS

BASIC CHILLER CONTROL

Basic chiller control is a sensor in the chilled water supply or return and a controller to provide a control signal to a capacity control actuator. Capacity control is unique to each compressor type. Summarized, the controls for each compressor type are:

1. Centrifugal—Controller output operates a pneumatic or electric actuator to position inlet vanes as a function of the controlled temperature. If speed control is available, the controller sequences motor or rotor speed with inlet vanes.
2. Reciprocating—Controller provides a stepped output to sequence refrigerant solenoid valves, valve unloading, hot gas bypass, or multiple compressors as a function of controlled temperature.
3. Screw—Controller operates speed control or a pneumatic or electric actuator to position sliding bypass valve in response to temperature input.
4. Absorption—Controller output operates a valve to modulate the steam, hot water, or gas supply to maintain controlled temperature.

Capacity high limit controls are used on centrifugal and screw compressors to limit electrical demand during high load periods such as morning cool-down. A load limiting control reduces motor current draw to an adjustable maximum. Capacity of some chillers can be reduced to as low as 10 percent.

Most chillers with modulating capacity control use proportional-integral control, and often receive their chilled water setpoint from a BMCS to optimize building energy efficiency.

When chilled water discharge temperature control is used, offset can be reduced and control improved by using return water temperature to reset the supply setpoint upward at light loads to reduce the supply to return chilled water temperature difference.

Proportional-integral (PI) control improves the accuracy of control. When integral control is used, provisions to prevent integral wind-up must be made. Integral wind-up during system shut-down causes overshoot on start-up. For more information on PI control, refer to Control Fundamentals section.

SYSTEM CONTROLS WHICH INFLUENCE THE CHILLER

Whatever the configuration of a chilled water system, proper control is necessary to meet the overall system requirements. Condenser and chilled water temperatures establish refrigerant pressure and energy needed per unit of cooling. Minimum condenser temperature limits vary for different chiller designs. Condenser temperatures should be maintained as close to the minimum limits as possible to minimize refrigerant pressure. Actual condenser water temperature is dependent on outdoor wet bulb temperatures. Chilled water temperature is dependent on system design and building load.

SAFETY CONTROLS

When an unsafe condition exists, the compressor should stop automatically. Safety cutout controls may have automatic or manual reset and include the following:

1. High condenser pressure.
2. Low refrigerant pressure or temperature.
3. Back-up for the low chilled water temperature controller (on some reciprocating chillers).
4. High motor temperature.
5. Motor overload.
6. Low oil pressure.
7. Low oil sump temperature.
8. High oil sump temperature.
9. Chilled water flow interlock.
10. Condenser water flow interlock.

The preceding are all two-position (on-off) controls. In addition, modulating limit controls sensing high condenser pressure or low evaporator pressure-temperature reduce compressor capacity to avoid the safety cutout conditions of Items 1 and 2.

CHILLER/BMCS INTERFACE

Most chillers are supplied with microprocessor controllers with a significant database of safety, operating, monitoring, and setpoint status and values. The BMCS normally provides control of the chilled water pump, the cooling tower fans, and the chiller system (AUTO/OFF commands to the chiller controller). The chilled water temperature setpoint and on occasions the maximum load setpoint are also dictated by the BMCS.

It is desirable for the BMCS to have access to the chiller-controller database, but due to the cost and complexity of a custom interface to convert the data to a format acceptable to the BMCS, it is seldom done. Adoption of open communication standard protocols as the ASHRAE BACnet and the Echelon LonMark™ will replace the expensive interfaces with direct interfaces.

CHILLED WATER SYSTEMS

CENTRAL COOLING PLANTS

The central cooling system generates chilled water for distribution to a building or group of buildings. It consists of one or more chillers. Multiple chillers may all be the same or different capacities and/or different types. The energy may be provided by electricity or a fuel-combustion source. Central chiller system optimization is an important control function to minimize energy use, especially in multiple chiller plants. The control program must be dynamic and constantly check current conditions and adjust chiller system operations accordingly. A control program must select the most efficient loading and chiller combinations then, sequence pumps and control cooling towers to match the current load condition. Built-in safeguards prevent short cycling and exceeding demand limits. Strategies for total chiller system optimization include:

1. Supplying chilled water at a temperature that minimizes chiller and pump energy while satisfying the current demand load.
2. Selecting the chiller or chiller combination in multiple chiller plants to satisfy the current load at minimum operating cost. The influence of refrigerant pressures and chiller efficiency curves must be considered.

3. Using rejected heat when a heating load exists at the same time as a cooling load.
4. Using thermal storage to store day time rejected heat and/or night time cooling. Thermal storage can also reduce the size of chiller equipment.

SINGLE CENTRIFUGAL CHILLER CONTROL

Capacity control is the primary method used to control a single chiller to meet the cooling load. Typically centrifugal chiller capacity control is accomplished by a chiller discharge water temperature controller. Discharge control responds quickly to load changes to maintain the chilled water temperature. The chilled water supply temperature may be reset from chilled water return temperature or from the zone with the greatest load. To ensure that all loads are met, resetting based on zone demand requires monitoring all the chilled water valves on the fan systems. Resetting from return water temperature recognizes the average temperature only and not the individual loads.

Where chilled water constant speed pumping power (kW) is more than 25 to 33 percent of the compressor power (kW), increases in chilled water temperature could force the use of more pumping energy than can be saved in reduced compressor energy. This is because chilled water control valves open wider due to the increased water temperature. The increased flow requires the pump(s) to use more power. In these cases, chilled water reset should not be used or should be limited to reset only when flow is below the break even point of compressor versus pump energy.

SINGLE CENTRIFUGAL CHILLER CONTROL APPLICATION

FUNCTIONAL DESCRIPTION

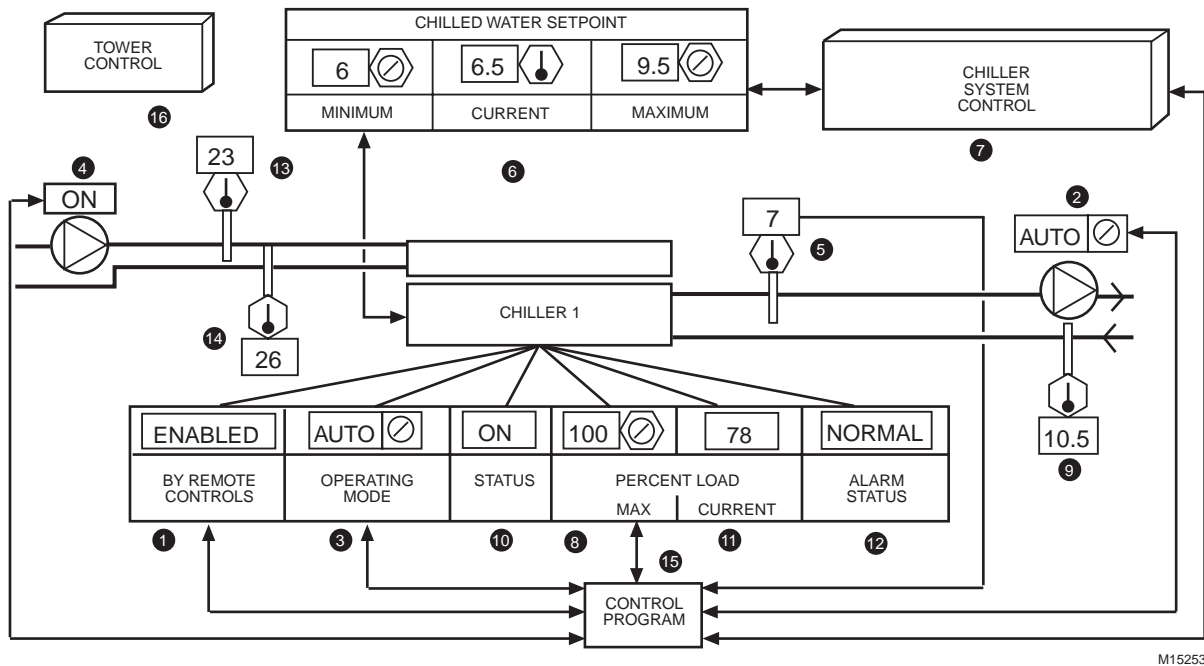

M15253

Fig. 9. Single Chiller Control Graphic.

Item No.	Function
1	Indicates when chiller system is required by fan system.
2	Chilled water pump ON-OFF-AUTO function. In AUTO pump runs when fan systems need chilled water.
3	Chiller ON-OFF-AUTO function (In ON and AUTO chilled water flow required for chiller to run).
4	Condenser pump status. Pump started by chiller controls when chilled water needed.
5,6	Chiller leaving water temperature and setpoint.
7	Icon to select chiller control dynamic sequence display (Fig. 10).
8	BMCS commandable load limiting function.
9-14	Operator information.
15	Control program coordinates chiller control.
16	Icon to select cooling tower control displays.

CHILLED WATER SYSTEM

CHILLED WATER SETPOINT		
6	6.5	9.5
MINIMUM	CURRENT	MAXIMUM

ANYTIME ANY AHU VALVE IS OPEN GREATER THAN 20% FOR MORE THAN 3 MINUTES AND THE TIME IS BEFORE 1545 THE CHILLED WATER PUMP STARTS AND ENABLES THE CHILLER SYSTEM CONTROLS.

AT CHILLER START-UP, THE CHILLED WATER TEMPERATURE SETPOINT IS 6.5. ANYTIME ALL AHU CHILLED WATER VALVES ARE LESS THAN 85% OPEN, THE SETPOINT INCREMENTS UP AT THE RATE OF 0.15 DEGREES EVERY 5.5 MINUTES UP TO A MAXIMUM OF 9.5 DEGREES.

ANYTIME ANY AHU CHILLED WATER VALVE IS FULL OPEN, THE CHILLED WATER TEMPERATURE SETPOINT DECREMENTS DOWN AT THE SAME RATE TO A MINIMUM OF 6 DEGREES.

M15254

Fig. 10. Single Chiller Control Dynamic Sequence Display.

Features

1. Automatic start-stop and setpoint optimization of chiller.
2. User friendly monitoring and adjustment.
3. Optimized unoccupied operation.
4. Chiller cannot start late shortly before the unoccupied period begins.

Conditions For Successful Operation

1. Control network, software, and programming advises chiller controller of AHU chilled water demands.
2. Interlock and control wiring coordinated with the chiller manufacturer.
3. Appropriate cooling tower and control.
4. For single-chiller systems without primary-secondary pumping, three-way air handling unit valves may be used for 80 to 85 percent of the chilled water flow (Small valves, up to 15 to 20 percent total flow, may be two-way, which are simpler to pipe.) If all two-way valves are provided on single pump systems, chilled water flow or pressure controls (See DUAL CENTRIFUGAL CHILLERS) are provided to maintain the required flow (varies with chiller manufacturers) through the chiller. Do not use three-way valves when diversity is used in the chiller system design.

NOTE: Little pumping energy can be saved on a single-pump single-chiller system by using two-way AHU control valves since the chiller usually requires high flow anyway.

5. During the unoccupied period the 80 percent load limiting parameter (see SPECIFICATION following) is based on the assumption that AHUs are VAV and are operating under a reduced maximum airflow setpoint during all unoccupied cooling modes (see the Air Handling System Control Applications) to save fan energy and place the chiller operation in the maximum efficiency range.
6. Chilled water temperature reset from AHU chilled water valve position requires:
 - a. No valve always full open.
 - b. Maximum of 30 to 40 valves. With too many valves the probability that one valve will always be open is very great.
 - c. Zone setpoint discipline is maintained. Lowering setpoints to resolve complaints may result in one or more valves being always open.
7. Chilled water temperature reset timing increments are compatible with valve control response. If the temperature reset is too fast, the valve cannot adjust to the new temperature, resulting in instability.

Specification

The chiller system operation shall be enabled anytime the time of day is less than 1545 and any AHU chilled water valve is open greater than twenty percent for more than three minutes. Anytime the chiller system is enabled, the chilled water pump shall run.

Anytime chilled water flow is proven via a chilled water pump current sensing relay, the chiller controls shall be enabled to operate under factory controls, subject to a chiller software ON-OFF-AUTO function (chilled water flow must still be proven in the “ON” mode). Provide control and interlock wiring per the chiller manufacturers recommendation.

Upon a call for chilled water, the chiller controls shall start the condenser water pump and energize the cooling tower fan controls.

When condenser water flow is proven via a condenser water pump current sensing relay, the chiller shall start, operate, and load under chiller factory controls to maintain the chilled water temperature setpoint, 7.5°C at start-up.

Anytime all chilled water valves are less than 85 percent open, the chilled water temperature setpoint shall be incremented at a rate of 0.15K every 10 minutes up to a maximum of 11°C.

Anytime any chilled water valve is full open, the chilled water temperature setpoint shall be decremented at a rate of 0.15K every 10 minutes down to a minimum of 7°C.

The maximum allowable percentage of chiller full load electrical current shall be commandable from the BMCS, and shall be 80 percent during all unoccupied periods of operation.

MULTIPLE CHILLER SYSTEM CONTROL APPLICATIONS

Multiple chiller systems offer standby capacity and improved economy at partial loads. Multiple chiller systems may be piped for either parallel or series chilled water flow.

In the parallel piped arrangement (Fig. 11), return chilled water is divided among the chillers then recombined after chilling. Two methods of operation at light loads are depicted. One uses a pump and a check valve for each chiller. The other uses a common pump with an isolation valve for each chiller. Multiple pumps with check valves allow one chiller and the associated pump to be shut down during light load conditions to save energy and require that the system be able to operate with the reduced flow. The check valves prevent reverse flow through the shut down chiller. Use of a common pump and isolation valves require that the operating chiller be able to withstand full system flow. The isolation valves allow the operating chiller to supply only the chilled water temperature required to meet system demands. Without the isolation valves, half of the water flows through the chiller which is shut down and is not cooled. When the uncooled water is mixed with the cooled water, the temperature will be the average of the water temperatures. As a result, the on-line chiller must supply water cool enough so that the average will satisfy the primary sensor and thus the system. To meet this requirement the on-line chiller may need to supply water close to the freezing point.

The temperature sensor in the common chilled water supply is the primary capacity control. The temperature low limit control prevents the outlet temperature of each chiller from going too low. A return water temperature sensor can be used in conjunction with a supply water temperature sensor to turn off one chiller in light load conditions.

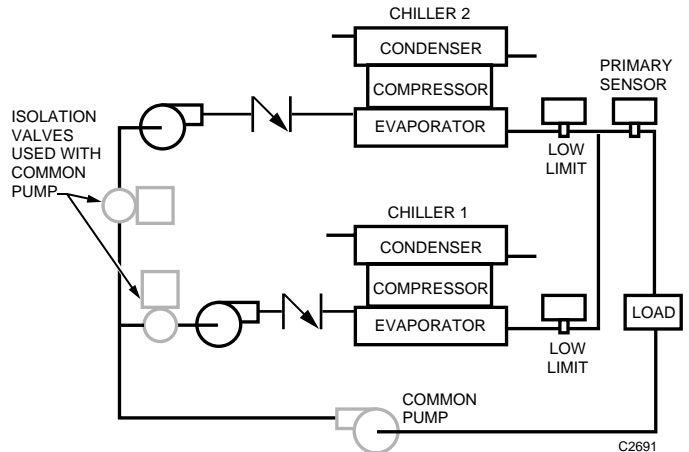

Fig. 11. Parallel Piped Chillers.

In the series arrangement (Fig. 12) chilled water pressure drop is higher if the chillers are not designed for higher flow. At partial loads, compressor power consumption is lower than for the parallel arrangement.

When the condensers of series units are water cooled, they are piped in series counterflow to balance loading. When piped series-counterflow, Chiller 1 receives warmer condenser and chilled water while Chiller 2 receives colder entering condenser and chilled water. This makes refrigerant pressure approximately the same for each chiller. The controls may be set to shutdown either chiller at partial loads.

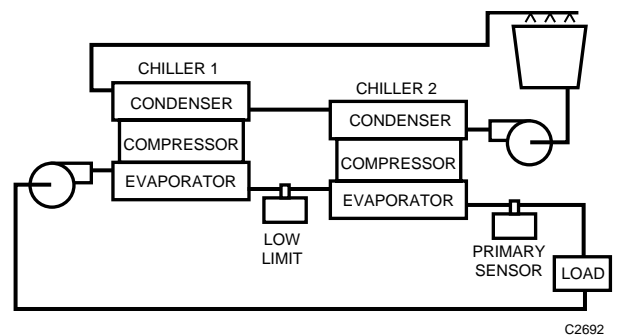
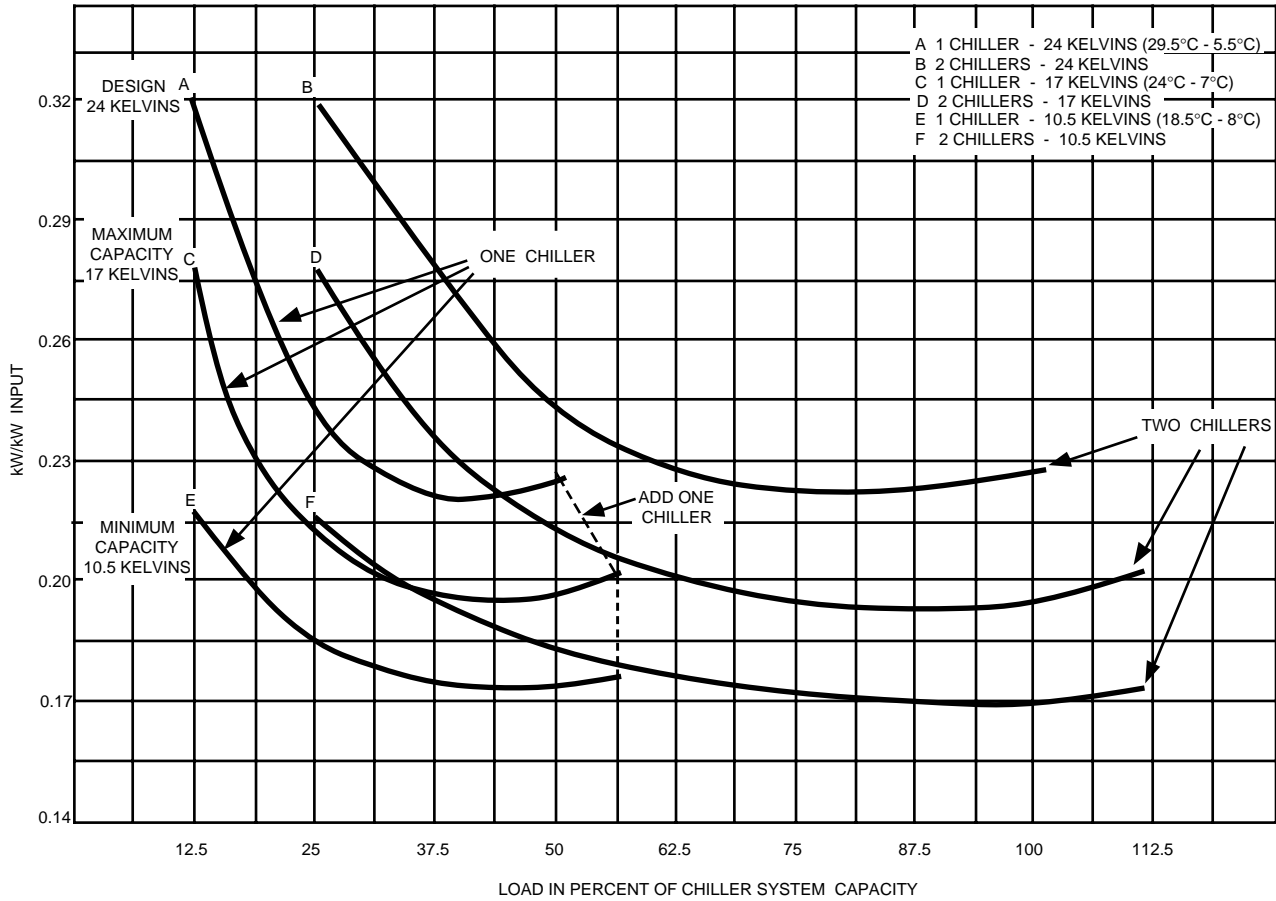

Fig. 12. Series Piped Chillers.

When two chillers of equal size and similar characteristics are used, the point at which the second chiller is activated is usually when the first chiller reaches 100 percent load. This is demonstrated in Figure 13 which plots kilowatt per kilowatt versus load for one chiller and two chillers at various temperature differences between condenser and chilled water temperatures. Curves vary slightly for different temperature differences so a microprocessor-based control system is used for maximum efficiency. The microprocessor checks chilled and condenser water temperature, looks up chiller efficiency at those temperatures, and calculates the optimum changeover point.

Curves A and B in Figure 13 illustrate that for the chillers operating at design condition with a 24 kelvins temperature differential (ΔT) between chilled and condenser water the second chiller must be added when the first chiller reaches 100 percent load (50 percent of chiller system capacity). The next set of curves (C and D) show the chiller is more efficient because of the smaller ΔT (17K) and that the first chiller can be loaded to 110 percent (55 percent of system load) before the second chiller is added. The third set of curves shows the extremely efficient operation with a 10.5 kelvins ΔT .



C4084

Fig. 13. Efficiency-Two Equal Size Chillers.

DUAL CENTRIFUGAL CHILLERS CONTROL APPLICATION

FUNCTIONAL DESCRIPTION

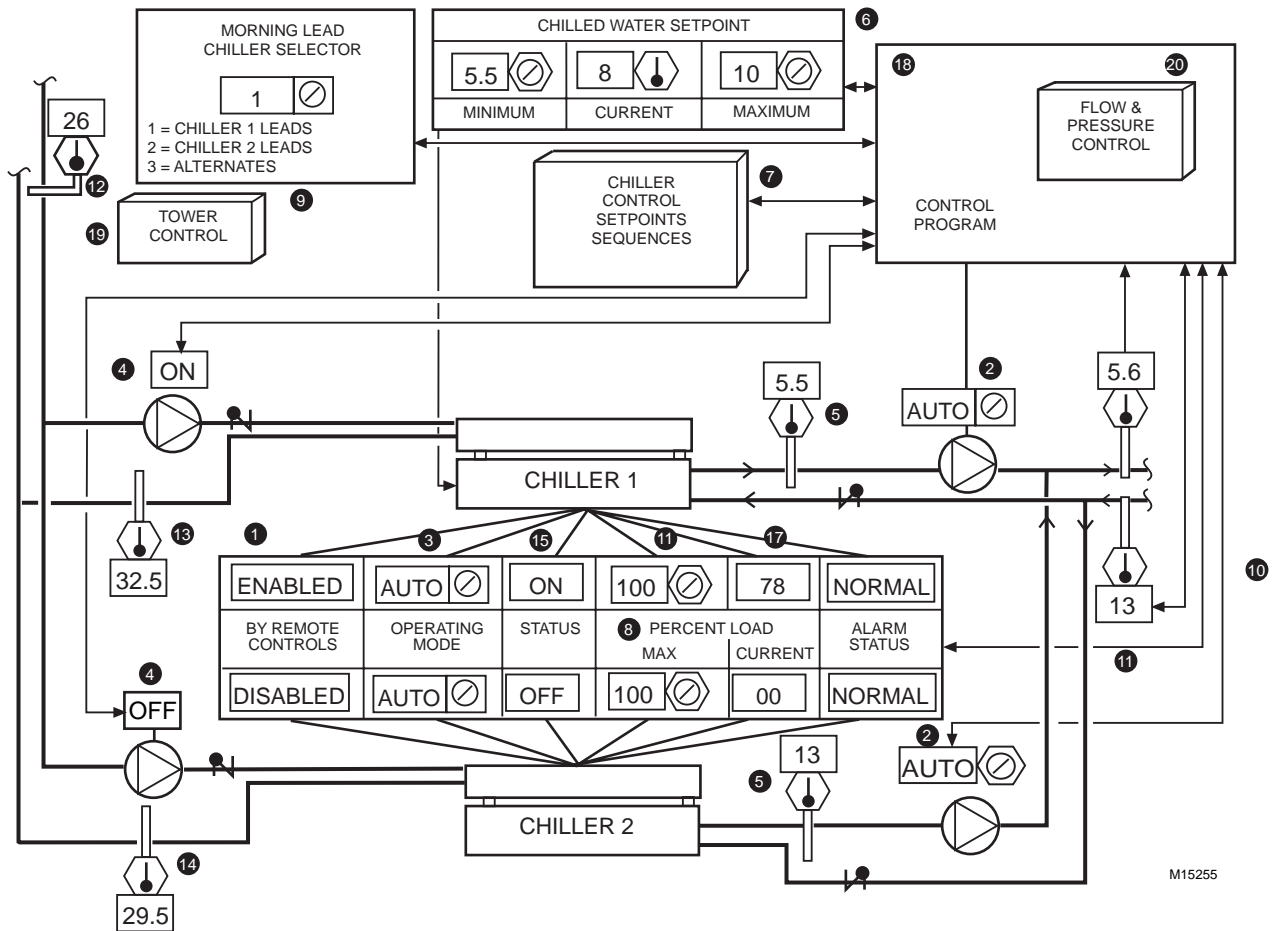

Fig. 14. Dual Centrifugal Chiller Control Graphic.

Item No.	Function
1	Indicates when chilled water is required by fan system.
2	Chilled water pump ON-OFF-AUTO function. In AUTO pump runs when system needs chilled water.
3	Chiller ON-OFF-AUTO function (In ON and AUTO chilled water flow required for chiller to run).
4	Condenser pumps status. Pumps started by chiller controls when chiller needed.
5,6	Chiller leaving water temperature and setpoint.
7	Icon to select chilled water setpoint reset dynamic sequence display (Fig. 15).
8	BMCS commandable load limiting functions.
9	Lead chiller selector function.
10-17	Operator information.
18	Control program coordinates chiller staging and control.
19	Icon to select cooling tower control displays.
20	Icon to select chilled water flow and pressure control displays.

CHILLED WATER SYSTEM

CHILLED WATER SETPOINT		
5.5	8	10
MINIMUM	CURRENT	MAXIMUM

ANYTIME ANY AHU VALVE IS OPEN GREATER THAN 20% FOR MORE THAN 3 MINUTES AND THE TIME IS BEFORE 1545, THE LEAD CHILLED WATER PUMP STARTS.

ANYTIME THE LEAD CHILLER HAS RUN LONGER THAN 90 MINUTES, THE CHILLED WATER TEMPERATURE IS GREATER THAN 0.5 DEGREES ABOVE SETPOINT FOR MORE THAN 4 MINUTES, THE BYPASS VALVE IS CLOSED, AND THE TIME IS BEFORE 1545, THE OFF CHILLED WATER PUMP STARTS.

ANYTIME BOTH CHILLERS ARE RUNNING AND THE WATER DIFFERENTIAL TEMPERATURE IS LESS THAN 2.4 KELVINS FOR MORE THAN 4.0 MINUTES, THE CHILLER WHICH HAS RUN LONGEST STOPS AND REMAINS OFF AT LEAST 30 MINUTES.

ANYTIME ALL AHU CHILLED WATER VALVES ARE LESS THAN 80% OPEN THE CHW TEMP. SETPOINT INCREMENTS UP AT THE RATE OF 0.15 KELVINS EVERY 5 MINUTES TO A MAXIMUM OF 11 DEGREES.

ANYTIME ANY AHU CHILLED WATER VALVE IS FULL OPEN, THE CHW TEMPERATURE SETPOINT DECREMENTS DOWN AT THE SAME RATE TO A MINIMUM OF 7 DEGREES.

ANYTIME ANY CHILLER IS RUNNING AND ALL AHU VALVES ARE OPEN LESS THAN 20% FOR MORE THAN 3 MINUTES, AND THE CHILLER HAS RUN GREATER THAN 30 MINUTES, THE CHILLED WATER PUMP STOPS.

M15256

Fig. 15. Dynamic Chiller Control Display.

Features

1. Automatic start-stop, staging, and setpoint optimization of chillers.
2. User friendly monitoring and adjustment.
3. Optimized unoccupied operation.
4. Chiller that has run longest since last start is first to stop.
5. Chillers cannot start late (shortly before the unoccupied period begins).

Conditions For Successful Operation

1. Control network, software, and programming advises chiller controller of AHU chilled water demands.
2. Interlock and control wiring coordinated with the chiller manufacturer.

3. Appropriate cooling tower and control is required. See COOLING TOWER AND CONDENSER WATER CONTROL.
4. Two-way AHU control valves. This allows good single-chiller, single pump operation.
5. Appropriate chilled water flow and differential pressure controlled bypass valve to keep the minimum required flow through the chillers (varies with chiller manufacturers).
6. The unoccupied period 80 percent load limiting parameters are based on the assumption that VAV AHUs are operating under a reduced maximum airflow setpoint during all unoccupied cooling modes (see the Air Handling System Control Applications section) to save fan energy while simultaneously placing the chiller operation in its maximum efficiency range.

NOTE: When using two-way AHU valves with this coupled chiller configuration, exercise care in optimizing the chilled water temperature. With both chillers running, raising the chilled water temperature results in greater flow and a smaller ΔT which must be considered in the chiller shedding strategy. For an example of a pressure bypass system, see DUAL PUMPS, DUAL CHILLERS, PRESSURE BYPASS, 90 PERCENT CHILLER FLOW, DIRECT RETURN.

Specification

The chiller system operation shall be enabled anytime the time of day is before 1545 and any AHU chilled water valve is open greater than twenty percent for greater than three minutes. Anytime the chiller system is enabled, the lead chilled water pump shall run.

Anytime the lead chiller has run longer than 90 minutes, the chilled water temperature has been greater than 0.5 kelvins above the chilled water temperature setpoint for greater than 4 minutes, and the time is less than 1545, the off chilled water pump shall start.

Anytime both chillers are running and the chiller plant water differential temperature has been less than 2.4 kelvins for greater than 4 minutes, the chilled water pump with the longest "on" duration since the last start shall stop and remain off at least 30 minutes.

Anytime chilled water flow is proven via a chilled water pump current sensing relay, the respective chiller controls shall be enabled to operate under factory controls, subject to a chiller software ON-OFF-AUTO function (chilled water flow must still be proven in the "ON" mode). Provide control and interlock wiring per the chiller manufacturers recommendation.

Upon a call for chilled water, the chiller controls shall start the condenser water pump and energize the cooling tower fan controls.

When condenser water flow is proven via a condenser water pump current sensing relay, the chiller shall start, operate, and load under chiller factory controls to maintain the chilled water temperature setpoint, 6.5°C at start-up.

Anytime all chilled water valves are less than 80 percent open, the chilled water temperature setpoint shall be incremented at a rate of 0.15 kelvins every 5 minutes up to a maximum of 10°C.

Anytime any chilled water valve is full open, the chilled water temperature setpoint shall be decremented at a rate of 0.15 kelvins every 5 minutes down to a minimum of 5.5°C.

The maximum allowable percentage of chiller full load electrical current shall be commandable from the BMCS, and shall be 80 percent during all unoccupied periods of operation.

SIMILAR MULTIPLE CENTRIFUGAL CHILLERS CONTROL APPLICATIONS

Equal Sized Centrifugal Chillers Control

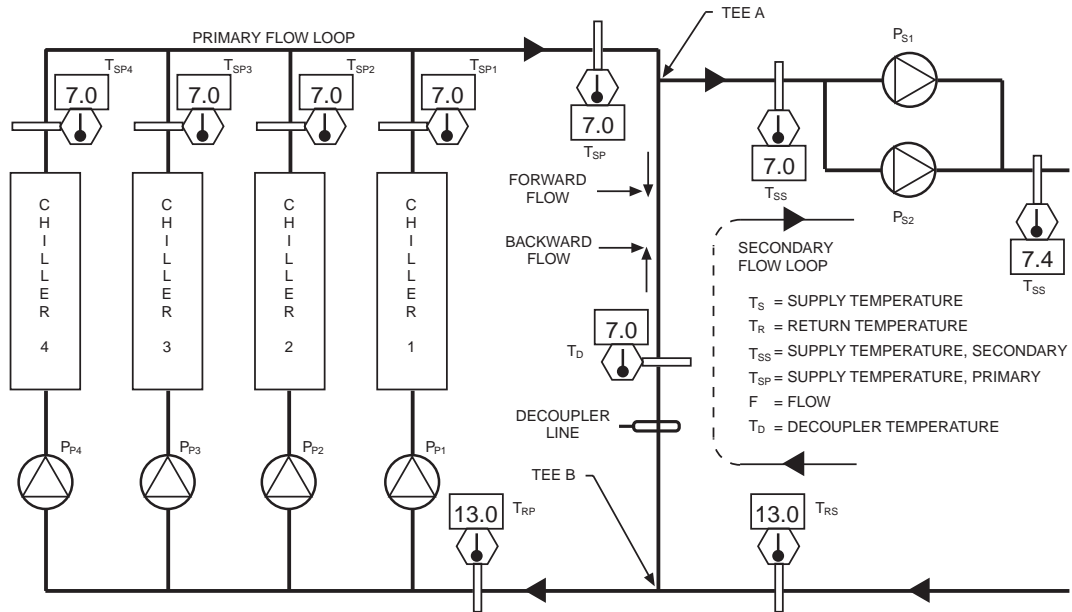

$$F_s = F_p \frac{\Delta T_p}{\Delta T_s}$$

WHERE F_s = SECONDARY FLOW
 F_p = PRIMARY FLOW,
 ΔT_p = DIFFERENTIAL TEMPERATURE, PRIMARY
 ΔT_s = DIFFERENTIAL TEMPERATURE, SECONDARY

NOTE: F_p = SUM OF PRIMARY PUMP FLOWS
 BASED UPON TEST-AND-BALANCE
 DATA AND PUMP ON-OFF STATUS.

M15257

Fig. 16. Multiple Equal Sized Chillers Control Graphic.

SYSTEM DESCRIPTION

Figure 16 shows a typical “decoupled” multiple chiller system. Each chiller has a (primary) dedicated constant speed pump selected to produce the chiller design flow through the primary loop, including the “decoupler line”. The decoupler line isolates the primary and secondary pumping systems and handles any imbalance between the two flow loops. The decoupler line is typically sized to handle the flow of the largest primary pump at a negligible pressure drop, should be at least 6 to 10 pipe diameters in length, and the tees at each end should be configured as shown to oppose any undesirable induced flow forces. Decoupler flow should always be forward, not to exceed the flow of one chiller. Any backward decoupler flow will dilute the secondary chilled water supply with secondary return water thus raising the secondary supply temperature above design.

The secondary pumping system is variable volume and may contain many varieties of pumping loops.

Control, the staging of chillers on and off, is normally:

- Start a chiller anytime the decoupler has a backward flow.
- Stop a chiller anytime the decoupler forward flow exceeds that of the next chiller to be shed.

SOFTWARE PARTITIONING

From an operational and control perspective, the physical configuration of chiller plant digital controllers is usually transparent. The configuration varies, depending upon:

- Chiller staging algorithm.
- Redundant/backup control requirements.
- Condenser water system configuration.

NOTE: Where water leaving cooling towers becomes common before being extended to the chiller plant, a single cooling tower isolating, staging, and loading algorithm is usually preferred.

- Chiller monitoring requirements.
- Controller capacity for monitoring and control.
- Other project-unique requirements.

Figure 17 is a schematic of a digital system configuration. Each chiller has a dedicated cooling tower and a dedicated controller for chiller, cooling tower, and condenser water monitoring and control. Figure 18 shows a variation of Figure 17 where condenser water is common to all chillers and the cooling towers are staged in response to condenser water demand.

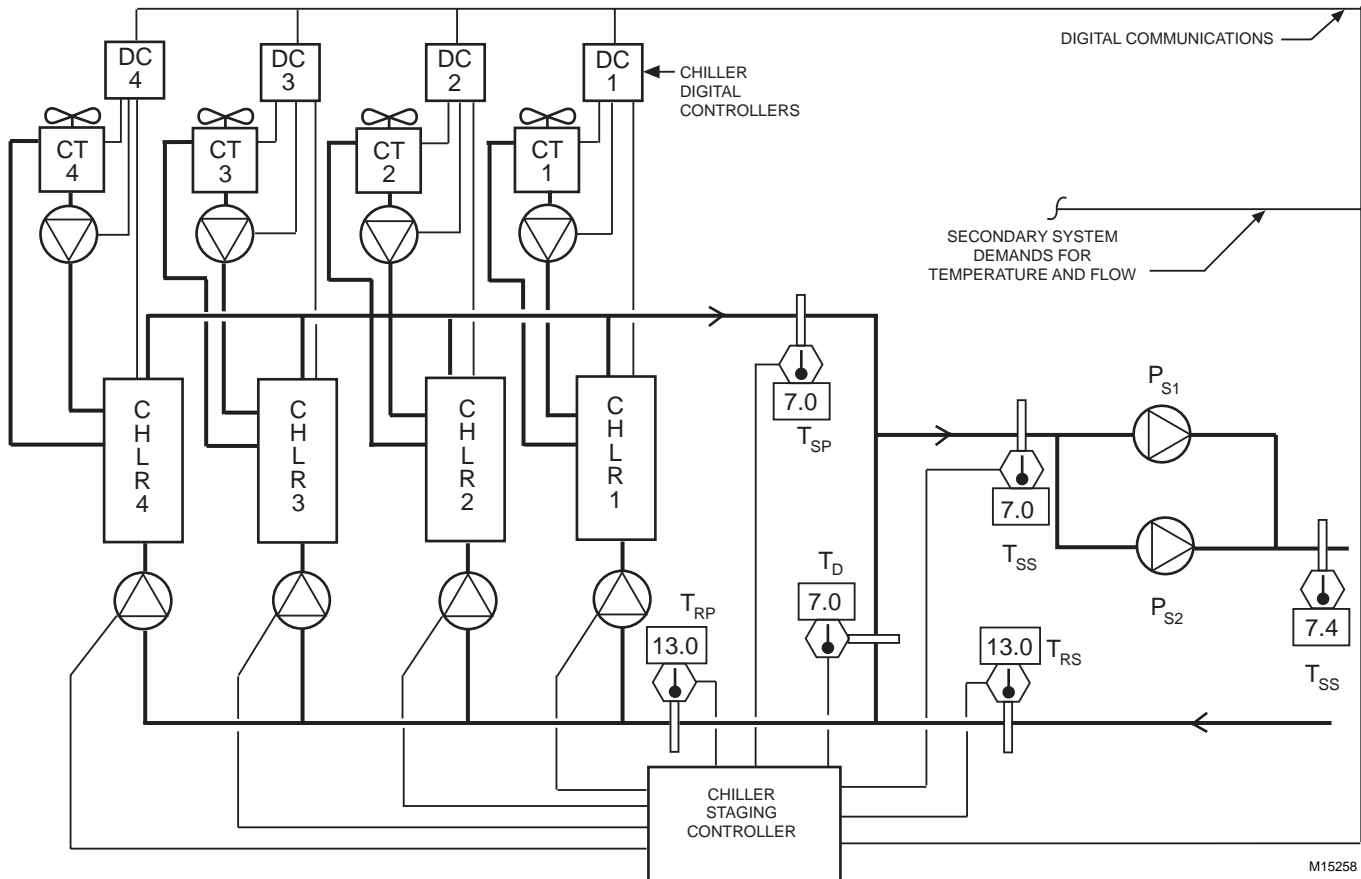

Fig. 17. Typical Digital Controller Configuration for Multiple Chillers.

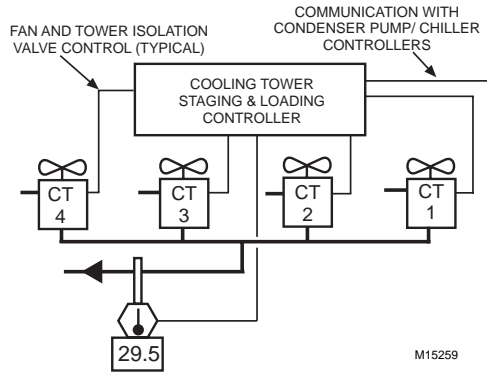

Fig. 18. Digital control of Sequenced Cooling Towers.

Multiple Centrifugal Chiller Sequencing

FUNCTIONAL DESCRIPTION

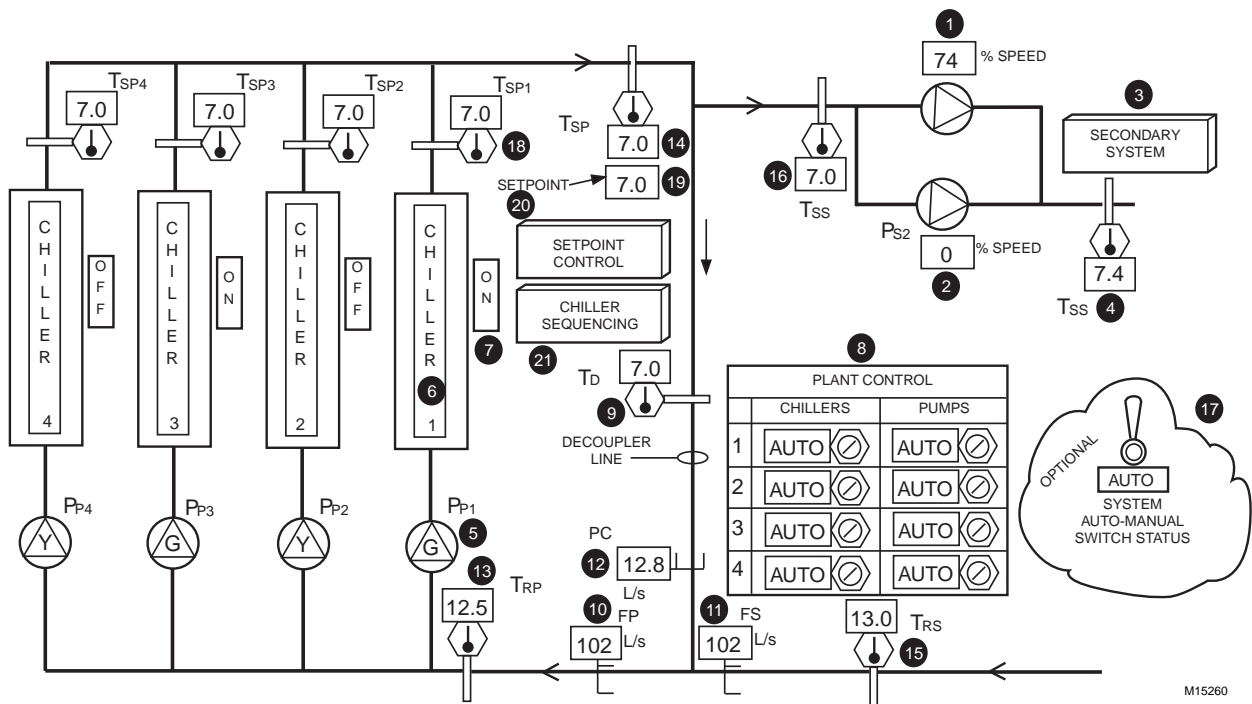

Fig. 19. Control Graphic for Multiple Similar Chillers.

Item No. Function

- | | | | |
|-----|---|-------|--|
| 1,2 | Secondary pump speeds. | 9 | Decoupler temperature—indicates direction of flow. |
| 3 | Icon for selection of secondary control details. | 10 | Primary flow—indicates primary loop loading. |
| 4 | Secondary pump leaving water temperature (operator information). | 11 | Secondary flow—indicates secondary loop loading. |
| 5 | Four chiller pump status indicators (green = on, yellow = off, red = alarm) (typical). | 12 | Decoupler flow the difference between primary and secondary flows. |
| 6 | Four Icons for selection of chiller detail graphic. | 13-16 | Temperatures for calculating secondary flow. |
| 7 | Four chiller status indicators (typical), operator information. | 17 | Status of optional AUTO-MANUAL toggle switch. |
| 8 | BMCS commandable AUTO-OFF functions for each chiller and ON-OFF-AUTO functions for each chiller pump. | 18 | Four chiller CHWS temperature indicators. |
| | | 19 | Operator information (from secondary system). |
| | | 20 | Icon for selection of chilled water setpoint details display. |
| | | 21 | Icon for selection of chiller sequencing display (Fig. 20). |

CHILLER SEQUENCING

CHILLED WATER PUMP OFF LONGEST IS STARTED UPON SECONDARY SYSTEM DEMAND FOR CHILLED WATER.

CHILLED WATER PUMPS ARE SEQUENTIALLY STAGED ON ANYTIME THE DECOUPLER TEMPERATURE EXCEEDS THE PRIMARY SUPPLY WATER TEMPERATURE GREATER THAN 1.1 KELVINS FOR GREATER THAN 3.0 MINUTES, BUT WITH NO LESS THAN 7 MINUTES BETWEEN STARTS.

CHILLED WATER PUMPS ARE STAGED OFF ANYTIME THE FORWARD DECOUPLER FLOW EXCEEDS 52.4 L/S FOR GREATER THAN 4.0 MINUTES, BUT WITH NO LESS THAN 4.0 MINUTES BETWEEN STOPS.

M15261

Fig. 20. Multiple Chiller Sequencing.

Features

1. Automatic start-stop sequencing of multiple decoupled chillers.
2. User friendly monitoring and adjustment.
3. Flow calculations without costly and maintenance-prone flow meters (see SPECIFICATION).
4. Chiller that has been off longest is next to start.
5. Constant flow through chillers with a variable flow secondary water system.

Conditions For Successful Operation

1. Control network, software, and programming to advise chiller plant controller of AHU chilled water demands.
2. Interlock and control wiring coordinated with the chiller manufacturer.
3. Appropriate cooling tower and control.
4. Two way AHU control valves provide variable flow secondary operation.
5. Precise and matched temperature sensors for accurate flow calculation. Refer to the flow equation in Figure 16.
6. Proper and precise positioning of primary return water well and sensor to get accurate measurement of mixed water temperature.
7. Digital controller configuration to suit cost and reliability requirements.

Specification

Chiller Plant Start-Up:

Anytime any secondary pump starts, the chiller plant controls shall be enabled, and the chiller pump that has been off longest shall start, subject to its software ON-OFF-AUTO function and its respective chiller software AUTO-OFF function. Pump/chiller combinations with either function OFF shall be removed from the control sequence.

When any chiller pump flow is proven, its respective chiller controls shall be energized. Upon a call for cooling by the chiller controls, the chiller controls shall enable the condenser water system controls and, upon proof of condenser water flow, the chiller shall start. Starting, loading, and interlock wiring shall be as recommended by the chiller manufacturer.

Chiller On-staging:

Anytime a chiller has operated greater than 50 minutes and the decoupler line temperature is greater than the chiller leaving water temperature setpoint by greater than 0.5 kelvins for greater than 5 minutes, the off chiller pump that has been off longest shall start.

Chiller Off-staging:

Anytime more than one chiller is operating and the decoupler has a supply chilled water flow in excess of the capacity of one chilled water pump for greater than 3.0 minutes, the chiller that has been running longest shall stop.

Chilled water flow calculations:

The primary supply water flow shall be calculated by summing the design water flow for all operating chiller pumps (each pump shall have a commandable value for its design flow).

$$F_p = \sum \text{Flow}(P_1, P_2, \dots, P_n)$$

The secondary water flow shall be calculated by dividing the product of the primary flow times the primary water differential temperature by the secondary water differential temperature.

$$F_s = \frac{F_p(T_{RP} - T_{SP})}{(T_{RS} - T_{SS})}$$

The decoupler flow shall be calculated by subtracting the secondary return water flow from the primary supply water flow.

$$F_D = F_p - F_s$$

The temperature sensors for flow calculation shall be platinum and software field-matched to within 0.05 kelvins at 10°C. The primary return water sensor shall be in a stainless steel well extended at least 50 percent of the distance across the pipe and positioned as far away from the decoupler/secondary return mixing tee as possible.

DISSIMILAR MULTIPLE CENTRIFUGAL CHILLERS CONTROL

When a multiple chiller system consists of chillers that are different in capacity and/or characteristics, the control problem becomes more difficult. The more dissimilarities between chillers, the greater the potential error in using a fixed sequence and changeover schedule. On-line computer analysis which takes into account the many variations in chiller conditions and different loading conditions can significantly improve efficiency.

For optimization of a multiple chiller system, the efficiency curves (kW per kW vs load) for each chiller at all temperature differentials (condenser water temperature vs chilled water temperature) from minimum load to design must be known. Condenser water, chilled water and return water temperatures and flows, when appropriate, are used to calculate the optimum chiller combination and loading for each chiller. If the decision is to add or drop a chiller, minimum off and on time restrictions for each chiller must be considered. If the on/off restriction prevents adding the desired chiller, a second decision is made to pick the next most efficient combination or wait for the on/off time restriction to expire.

The program checks water temperatures and flow constantly, recalculates the combinations and loading, and turns chillers on and off accordingly. If a peak power demand limitation applies, demand is checked and the demand limit avoided.

Starting at minimum load, a typical calculation sequence selects and starts the most efficient chiller for that load. Data is constantly checked and as the load increases to the optimum load for adding a second chiller (based on current load, temperature differences, and efficiency curves for that condition), a second chiller is selected and started. The loading of each chiller is then adjusted for maximum system efficiency. As conditions change and the load increases or decreases, the loading of each chiller is adjusted and chillers are added or dropped within the limitations of the parameters input into the computer.

ALTERNATIVE MULTIPLE DECOUPLED CHILLER CONTROL

Another chiller staging approach measures the secondary load (via flow and differential temperature) and stage the chillers on and off to match the demand. Since the leaving chilled water

temperature and the entering condenser water temperature are frequently optimized and chiller capacity varies with changes in either temperature, the per-chiller expected should be dynamically modified based upon manufacturers data regarding these variations. This complicates an otherwise simple strategy.

COMBINATION ABSORPTION AND CENTRIFUGAL CHILLER SYSTEM CONTROL

In large buildings or campus installations using medium or high pressure steam, a combination of a turbine driven centrifugal chiller and an absorption chiller may be economical. The steam is routed first to the turbine driving the centrifugal chiller (Fig. 21). The exhaust from the turbine is then routed to the absorption chiller. The system is symmetrical so that the absorption chiller uses all of the exhaust steam from the turbine. System water piping is shown in Figure 22.

With the ABSORPTION/COMBINATION SELECTOR switch (Fig. 21) in the combination position, temperature controller T1, with its sensor in the chilled water supply, controls the centrifugal compressor and pressure controller P1 controls the absorption chiller capacity control valve so that all of the exhaust steam from the centrifugal chiller turbine is used by the absorption chiller. This also maintains a constant back pressure on the turbine. When the cooling load is reduced, less exhaust steam is available from the turbine and P1 positions the capacity control valve to reduce the capacity of the absorption chiller until the steam balance is achieved. Whenever the absorption chiller condenser water pump is running, pressure controller P2 allows temperature controller T2 to control the cooling tower bypass valve to maintain the condenser water temperature required by the absorption chiller. The centrifugal chiller is normally turned off when the system load is 15 to 35 percent. The cooling tower fans are controlled by a temperature sensor in the tower leaving water.

With the ABSORPTION/COMBINATION SELECTOR switch in the absorption position, the centrifugal chiller is off and temperature controller T1 modulates the absorption chiller capacity control valve to maintain the required chilled water temperature. The pressure reducing valve (PRV) supplies steam to the absorption chiller.

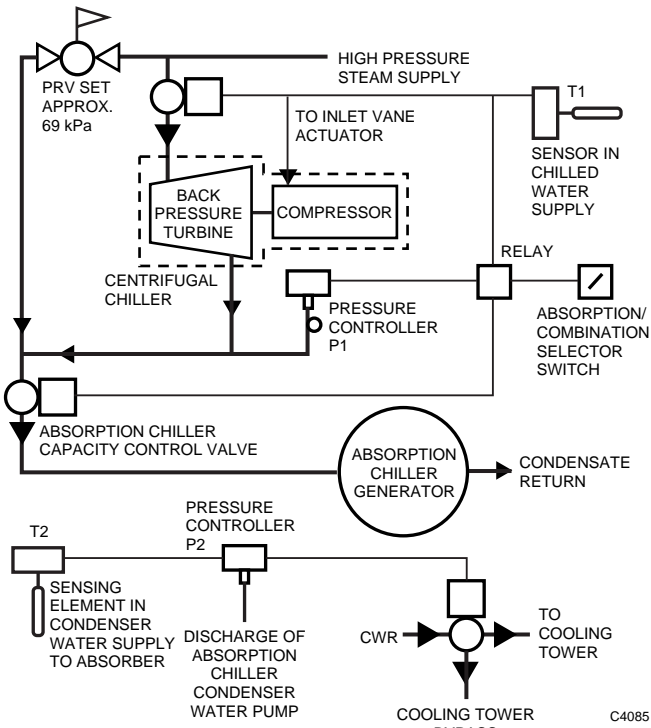

Fig. 21. Schematic of Combination Absorption/Centrifugal Chiller System Steam Piping and Control Circuit.

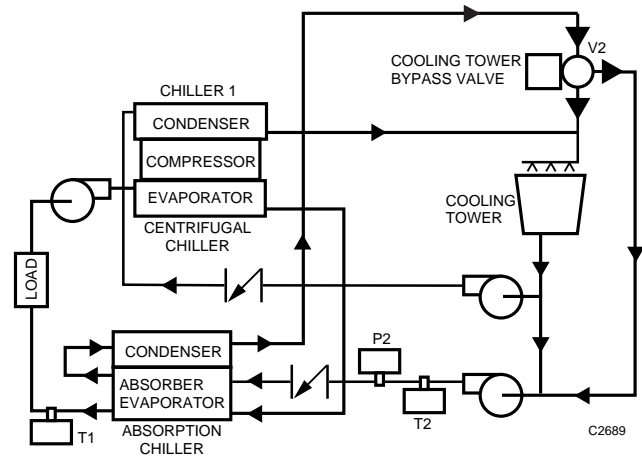

Fig. 22. Schematic of Combination Absorption/Centrifugal Chiller System Water Piping.

Figure 23 compares the steam consumption of individual chillers to a combination system showing the savings using the combination system. The range of centrifugal cutout points indicates where most centrifugal chillers are shut down and the absorption chiller provides all cooling required by the system.

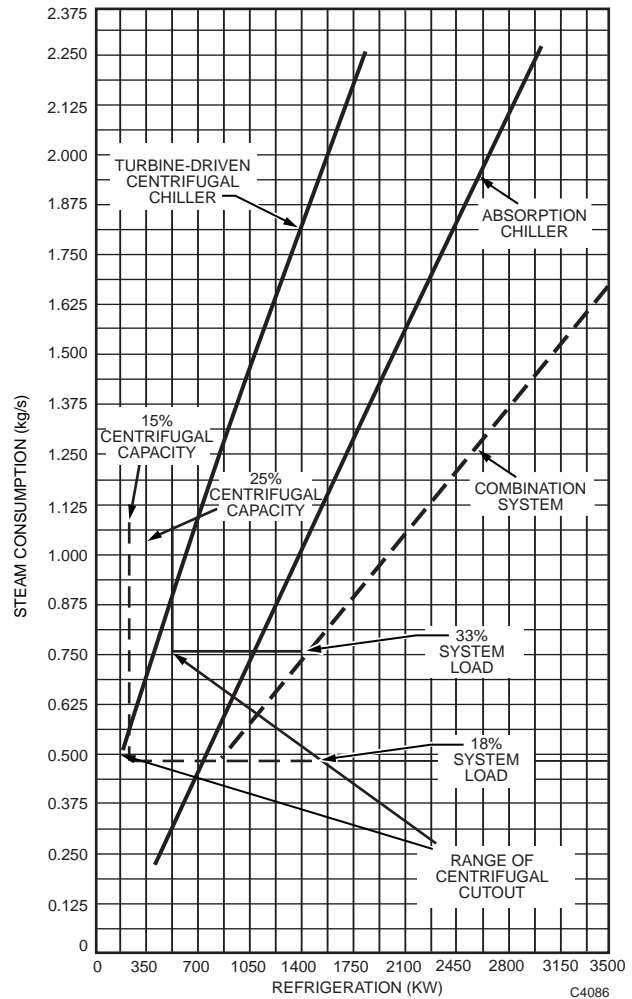

Fig. 23. Typical Steam Consumption, Individual and Combination Chillers.

CHILLER PUMP OPTIMIZATION

Pump configuration (variable water flow versus constant water flow) also affects chiller system efficiency. Constant water flow causes the largest change in efficiency from system no load to design because the pump energy becomes a greater percentage of the total energy input at light load conditions. Variable water flow, using two-way load valves or variable speed pumps, maintains the pump load at nearly a constant percentage of the total energy input at all loads. If a chiller system has constant water flow, chiller optimization must include pump energy usage as part of the power calculation to account for energy cost variations over the range of loads. In a chiller system using variable water flow, it is not necessary to account for pump energy cost. Refer to HOT AND CHILLED WATER DISTRIBUTION SYSTEMS AND CONTROL.

THERMAL STORAGE CONTROL

GENERAL

Thermal storage is used to save heating or cooling for future use. Typically enough storage is provided to meet the load requirements for a 24-hour period. During the cooling season, storage of low cost night time cooling can save energy and demand charges and reduce the chilled water generating equipment design size. During the heating season, storage of rejected day time excess refrigeration heat or solar heat can be used for night time heating loads. Storage may use a water tank or ice bin for cooling and a water tank or thermal conducting fluid for heat. The storage efficiency depends on the amount of insulation and, in the case of water storage, on minimizing the mixing of return water with storage water. Mixing in water storage can be minimized by use of a segmented container for storage (Fig. 24).

Primary control requirements are storage charge and storage discharge at the proper times and rates. Storage charge, storage discharge, and instantaneous cooling are the three basic control modes. Combinations of the basic control modes may be required to meet the load or predicted load. When the predicted load is high, the chiller provides chilled water for both the current load and for storage. When the predicted load occurs, the stored cooling is added to the chiller output.

CONTROL MODES

The appropriate control mode depends on the load predicted for next day, relative storage size, and relative costs of stored and instantaneous cooling, including electrical demand rate structures. The storage charging cycle is normally activated when cooling generation cost is lowest, such as at night when lower condenser water temperatures provide lower refrigeration pressure and when lower time-of-day electric rates may be applicable. The rate of charge should satisfy storage quantity requirements within the limits of the time available.

Use of stored energy versus instantaneous cooling energy is prioritized. When enough stored energy is available to satisfy the load through the peak demand period of the next day, only stored energy is used (storage priority). In this case, the charging cycle is scheduled to start when low cost cooling is available. The charging cycle is stopped when storage is sufficient for the next days load or when the storage capacity is filled. The storage discharge cycle is controlled to meet load conditions. If storage capacity is not large enough for the next day, the chiller supplements the use of stored cooling, as necessary. The control sequences for segmented chilled water storage (Fig. 24) are:

- Instantaneous Cooling Cycle: Pump P_1 is on and Pump P_2 is off. Valves V_C and V_D are closed. Valve V_I is controlled by ΔP and T_1 controls chiller.

- Charging Cycle: Valves V_D and V_I are closed and V_C is controlled by T_6 to maintain the flow rate at F_1 . Pump P_2 is off. T_1 controls chiller capacity to maintain 4.5°C CHWS temperature. When the T_5 (A through E) location, representing the needs for the next day, reaches 4.5°C , the charging cycle is stopped.
- Charging plus Instantaneous Cooling Cycle: Charging cycle continues while V_I is controlled from ΔP . Pump P_2 is off. The flow through the storage is T_{5E} to T_{5A} .
- Discharge Cycle (enough storage for anticipated load): Valves V_C and V_I are closed, chiller and Pump P_1 are off, and Pump P_2 is on. Valve V_D is controlled from ΔP .
- Discharge plus Instantaneous Cooling Cycle (not enough storage for anticipated load): Pumps P_1 and P_2 are on, V_C is closed. Chiller demand D_1 limits chiller capacity while T_2 positions V_I to maintain chilled water supply temperature. ΔP throttles valve V_D to provide flow from storage.

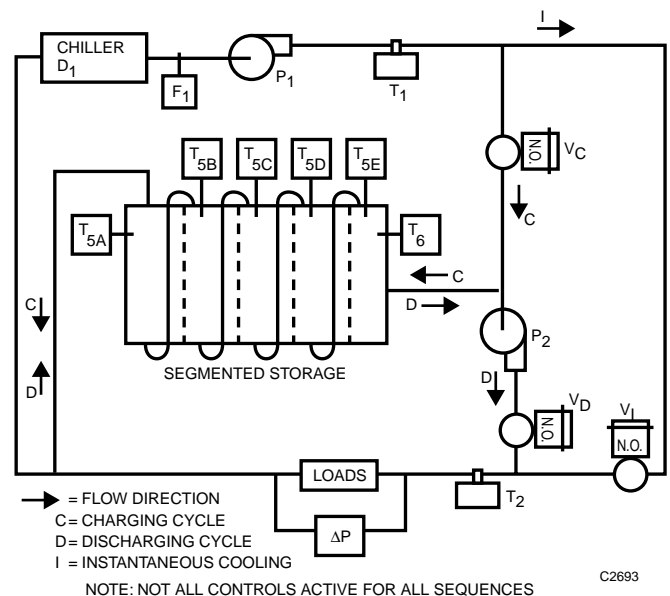

Fig. 24. Segmented Chilled Water Storage.

The chiller takes priority when stored energy costs are larger than instantaneous energy costs. Under these conditions the only cooling stored is that required to reduce the anticipated demand limit for the next day. Storage size and energy cost, including demand charges, establish the control strategies for this situation. The control objectives are to limit demand for the billing period and to minimize energy costs. Chiller discharge is controlled to meet load. The sequence of the control is to run the charging plus instantaneous cooling cycle, then stop charging when the quantity necessary to meet the anticipated demand limit for the next day is stored.

COOLING TOWER AND CONDENSER WATER CONTROL

COOLING TOWER PERFORMANCE CHARACTERISTICS

The cooling tower dissipates the heat collected from the building by the chiller and chilled water system by cooling the condenser water. Evaporatively cooled condenser water will cool refrigerant to within 3.5 kelvins of the outdoor air wet-bulb temperature. Air cooled condensers will cool refrigerant to within 11 kelvins of the outdoor air dry-bulb temperature. A cooling tower normally provides a refrigerant pressure about 17 kelvins lower than an air cooled condenser. This means an evaporative cooling tower provides a significantly lower cooling cost than an air cooled condenser.

Figure 25 shows water-air counterflow in a cooling tower. The fill increases the time that the water and air are in contact making the cooling tower more efficient. Fill is generally one of two types, either splash or film type. A splash type fill is a series of slats over which the water cascades. Film type fill causes the water to flow down thin closely spaced vertical sheets of plastic.

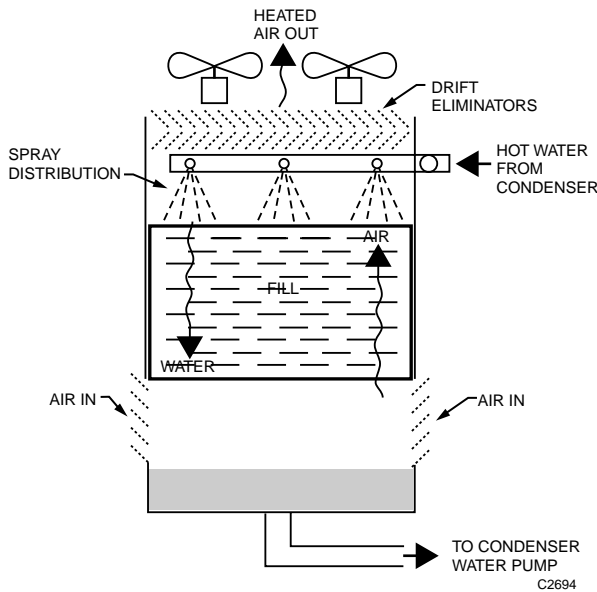
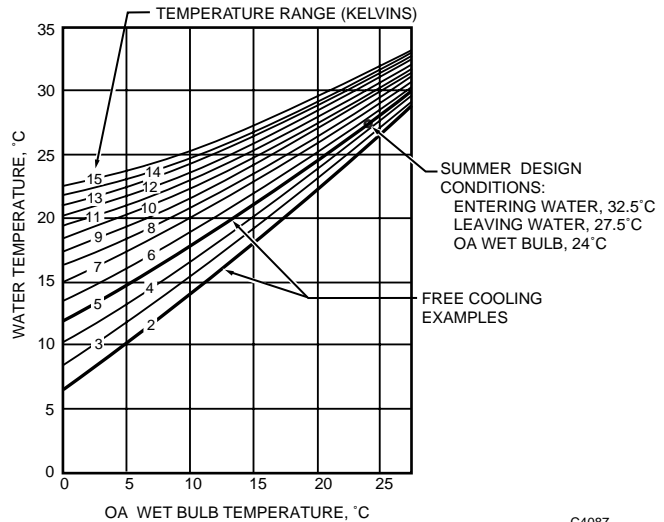

Fig. 25. Cooling Tower, Showing Water-Air Counterflow.

The range (inlet water temperature minus outlet water temperature) at design load of a cooling tower is determined by the amount of heat to be rejected and the water flow used to carry this heat to the tower. The cooling capability is then expressed as the design approach (approach specifies how close to the OA WB a cooling tower can cool water) at design range. Since most operation is at less than design load and/or design outdoor air temperatures, partial load operating characteristics have a strong influence on operating costs. Partial load operating characteristics are also used to establish the cooling capacity and capability for free cooling cycles at low outdoor air temperatures. Partial load characteristics for a tower at design flow rate are shown in Figure 26.



C4087

Reprinted by permission from the ASHRAE Handbook—1996 Systems and Equipment

Fig. 26. Typical Cooling Tower Partial Load Characteristics.

In Figure 26 summer design conditions are approximately 27.5°C cold water leaving the tower, 32.5°C water entering, and OA wet-bulb of 24°C. This is 3.5 kelvins approach at 5K range. Notice that the point is plotted on the 5K range line. The same tower used for free cooling at an OA wet-bulb of 10°C would provide 18°C leaving water (8 kelvins approach) at full load (5K range) or 14.5°C water (4.5K approach) at 40 percent load (2K range).

COOLING TOWER CAPACITY CONTROL

Fan control is the usual method of reducing tower capacity to maintain condenser water supply temperature in mild weather. A tower bypass valve is used to further limit cooling when the fans are off (Fig. 27). On-off fan control is very difficult at light loads because at light load the OA WB is usually well below design, which increases the tower capacity, producing short fan “on” periods. Controlling the air volume with dampers, blade pitch, or fan speed provides much closer and more stable control. A variable speed fan is more efficient than a two-speed fan when varying tower capacity.

Modulating tower water bypass for capacity control at low ambient temperatures can cause freeze-up in some tower designs.

Since, use of a tower bypass mixing valve in the tower leaving water can lower the pump suction pressure below the pumps minimum pressure, a diverting valve in the tower entering water is generally used.

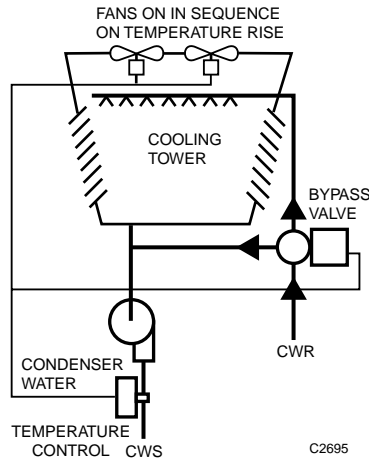

Fig. 27. Cooling Tower Control.

For minimum chiller energy usage, the condenser water temperature setpoint should be as low as can be safely used by the refrigeration system or as low as can be provided by outdoor air conditions. The approach value of the evaporative cooling tower indicates how close the cooled water temperature can come to outdoor air wet-bulb temperature at design conditions. When outdoor air is at a lower wet-bulb temperature than design, the tower can cool water to a lower temperature, but never to the wet-bulb temperature. Therefore, the controller setpoint should be at the lowest temperature attainable by the cooling tower to save chiller energy and not waste fan energy trying to reach an unobtainable value. Figure 28 is a reset schedule of condenser water setpoint as a function of outdoor air wet-bulb temperature with the minimum safe temperature indicated.

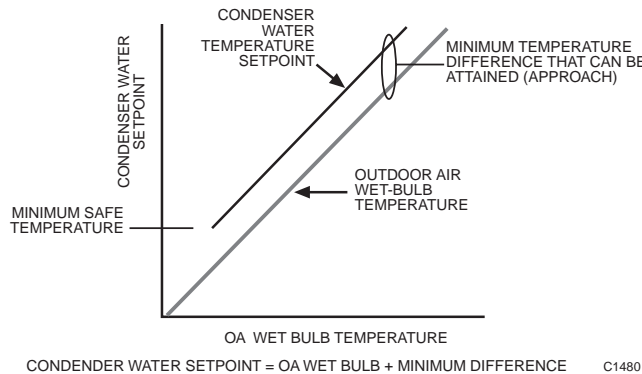

Fig. 28. Condenser Water Temperature Reset from Outdoor Wet-Bulb.

When wet-bulb reset is not used, a condenser water temperature setpoint around midpoint between the design (usually 29.5°C) and the minimum value acceptable to the chiller is satisfactory.

On-Off Cooling Tower Fan Control

On-off fan control is satisfactory where the load is always high and where several towers are banked together for multistage control.

On-off cooling tower control with a single setpoint for a PI control function produces questionable performance. A preferred solution starts the fan on a rise in condenser water temperature to 27°C, stops the fan on a drop to 23°C, and limits on periods to a minimum of 5 minutes. The 5 minute minimum on time can still produce water too cool for the chiller during light loads and low OA WB temperatures. The use of a modulating valve can prevent condenser water temperature from dropping below the lowest that the chiller can tolerate (valve control would be PI with a single setpoint). During below freezing OA conditions throttling condenser water into the tower can cause icing, cycling the valve open and closed can reduce freezing. The specification following provides warmer ice-melting water during colder weather.

Specification:

On a rise in condenser water temperature to 27°C the cooling tower fan shall start and on a drop in condenser water temperature to 23°C the cooling tower fan shall stop. When started, the cooling tower fan shall run a minimum of five minutes. When the OA temperature is above freezing, the bypass valve shall modulate if required to prevent the condenser water from falling below 21.5°C. When the OA temperature drops below 0°C, the bypass valve shall open to the bypass on a drop in condenser water temperature to a minimum acceptable temperature and open to the tower upon a rise in temperature. The temperature rise shall vary between 2.5 and 6 kelvins as the OA temperature varies from 0°C to -18°C.

NOTE: The variable temperature rise allows warmer water to enter the tower during extreme weather to encourage melting and reduce icing.

Two-Speed Cooling Tower Fan Control

For two-speed cooling tower fans, a single setpoint for a PI control function also produces unpredictable performance. A better solution would be one of absolute setpoints similar to that noted for on-off fans. If wet-bulb reset is used, the control objective is to turn the fan off at the optimum setpoint but at no less than the minimum temperature acceptable to the chiller plus 0.5 kelvins, and cycle to and from low and high speeds above this value with minimum on times for each speed and with no more than 7 speed changes per hour for fans under 3 meters in diameter or as required by the tower manufacturer. The specification following is typical.

Specification:

Condenser water temperature setpoint shall be equal to the OA WB plus 3.5 kelvins, or the minimum temperature acceptable to the chiller, whichever is higher. Fan shall stop when condenser water temperature drops to setpoint. Fan shall start at low speed when the temperature rises to the setpoint plus 3 kelvins, and shall not stop for a minimum of 9 minutes. Fan shall transition from low to high speed anytime it has run at least 3 minutes at low speed and the temperature is above the low-speed start point plus 1 kelvin or 29.5°C, whichever is lower. Fan shall run a minimum of 9 minutes on high speed, and shall transition from high speed to low speed if the temperature drops to a value equal to the switch-to-high-speed value minus 3 kelvins.

If required, use a valve control method similar to the one used for single speed fan control.

Variable Speed Cooling Tower Fan Control

For variable speed cooling tower fans, an EPID control function with WB optimized setpoint or fixed setpoint works well until the fan drops to a minimum safe speed, below which results in motor overheating. If the tower capacity is still excessive at minimum fan speed, the fan control mode reverts to on-off. During this mode, disable the PI function or when the fan is restarted it will start at a speed greater than the minimum, although the minimum speed was too great. This produces an undesirable short on time. The following is a possible application and specification:

SINGLE COOLING TOWER VARIABLE SPEED FAN CONTROL

Functional Description

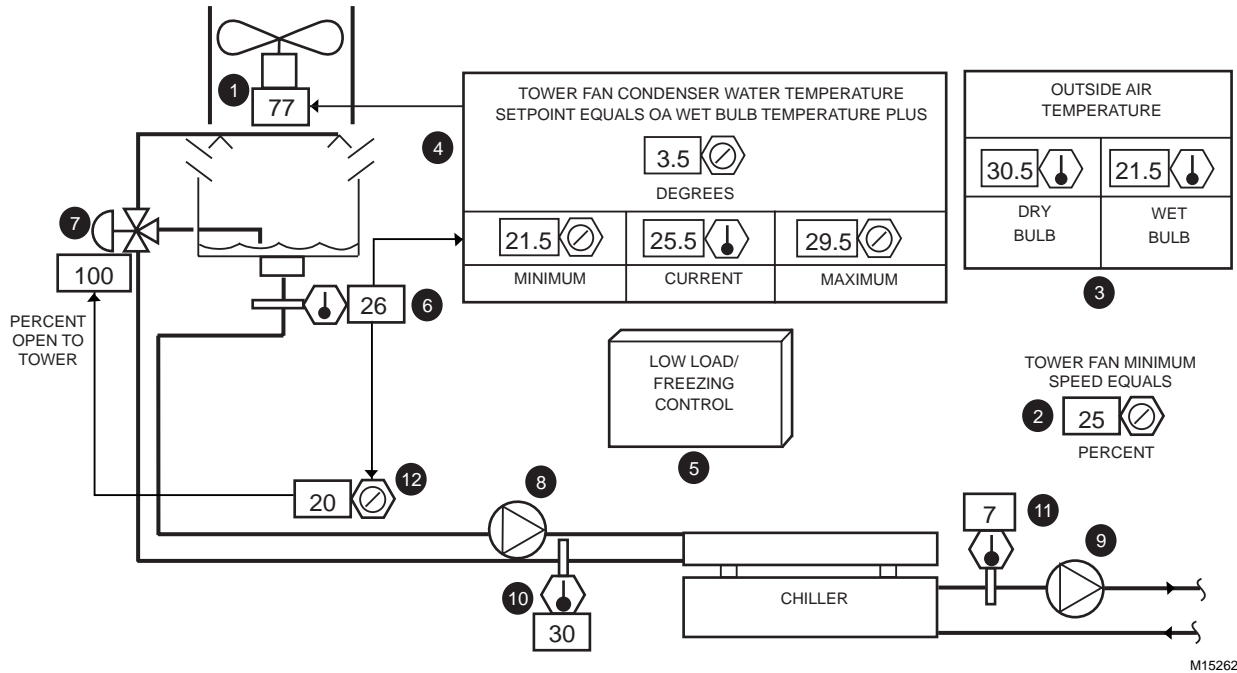

Fig. 29. Single Cooling Tower Variable Speed Fan Control Graphic

Item No.	Function
1	Indicates percent maximum tower fan speed.
2	Sets tower minimum speed.
3	Current OA conditions.
4	Sets minimum and maximum condenser water temperature setpoints and WB approach.
5	Icon to select tower low load control dynamic sequence display (Fig. 30).
6	Condenser water control sensor.
7	Displays valve position.
8,9	Dynamic pump symbols denote pump operation.
10,11	Operator information.
12	Sets valve control setpoint.

LOW LOAD CONDENSER WATER TEMPERATURE CONTROL:

TOWER FAN STOPS, VARIABLE SPEED CONTROL IS DISABLED, AND ON-OFF FAN CONTROL IS ENABLED IF LOAD DROPS AFTER FAN DROPS TO 25% SPEED.

ON-OFF CONTROL: FAN RESTARTS IF TEMPERATURE RISES TO SETPOINT PLUS 3.5 DEGREES. FAN STOPS IF TEMPERATURE DROPS TO SETPOINT, BUT RUNS A MINIMUM OF 7 MINUTES. DURING ON PERIODS OF ON-OFF CONTROL, THE FAN RUNS AT MINIMUM SPEED.

VARIABLE SPEED CONTROL RECOVERY: IF, AFTER CYCLING FAN ON FOR 3 MINUTES, THE TEMPERATURE RISES 1.1 KELVINS ABOVE THE "RESTART" TEMPERATURE THE FAN RESUMES VARIABLE SPEED CONTROL.

VALVE CONTROL: VALVE MODULATES WATER TO SUMP AS NECESSARY TO MAINTAIN VALVE CONTROL SETPOINT 20 DEGREES.

FREEZING CONTROL: IF OA IS BELOW FREEZING, VALVE SHALL SWITCH TO TWO POSITION CONTROL. VALVE SHALL OPEN TO SUMP AT VALVE CONTROL SETPOINT, AND SHALL REVERT BACK TO TOWER WHEN TEMPERATURE RISES TO SETPOINT PLUS DIFFERENTIAL. DIFFERENTIAL SHALL VARY FROM 2.5 TO 6.0 KELVINS AS OA VARIES FROM 0 TO -18 DEGREES.

M15263

Fig. 30. Cooling Tower Load Control Dynamic Display.

Features

1. Precise PI condenser water control above minimum load.
2. User friendly monitoring and adjustment.
3. Optimized condenser water temperature.
4. Freeze prevention cycle.
5. Fan motor light-load over-heating protection.

Conditions For Successful Operation

1. Control network, software, and programming to advise tower controller of chiller demands.
2. Interlock and control wiring coordinated with the chiller manufacturer.
3. Good OA RH sensor and WB calculation.
4. Proper project-specific setpoint and parameter settings.
5. If tower must operate with OA temperature below freezing, the diverting valve must be controlled two position, during freezing conditions.

Specification

Cooling tower controls shall be enabled anytime the condenser water pump runs. The cooling tower fan speed shall be modulated under EPID control down to a minimum 25%

speed to maintain a condenser water temperature setpoint equal to the OA WB temperature plus 3.5 kelvins, or a value equal to the minimum temperature acceptable to the chiller plus 1 kelvin, whichever is higher, but not to exceed 29.5°C. If the tower capacity is still excessive at minimum speed, control shall revert to an on-off algorithm, cycling the fan off at the minimum speed at a setpoint equal to the above setpoint, and back on at the minimum speed at a temperature equal to the off temperature plus 3 kelvins, with on cycles of no less than 7 minutes duration. If, after cycling the fan on for 3 minutes, the temperature rises above the "back on" setpoint by 1 kelvin, the EPID function shall be reinstated with a start value of 25% and a ramp duration of 90 seconds.

The tower diverting valve shall modulate to divert tower water to the sump if required to prevent the condenser water temperature from dropping below the minimum temperature acceptable to the chiller. When the OA temperature drops below freezing, the valve shall switch to two-position control, wherein the valve shall open to the sump when the water temperature drops to the setpoint and close when the temperature rises a differential which shall vary from 2.5 to 6 kelvins as the OA temperature varies from 0 to -18°C.

DUAL COOLING TOWER VARIABLE SPEED FAN CONTROL

Functional Description

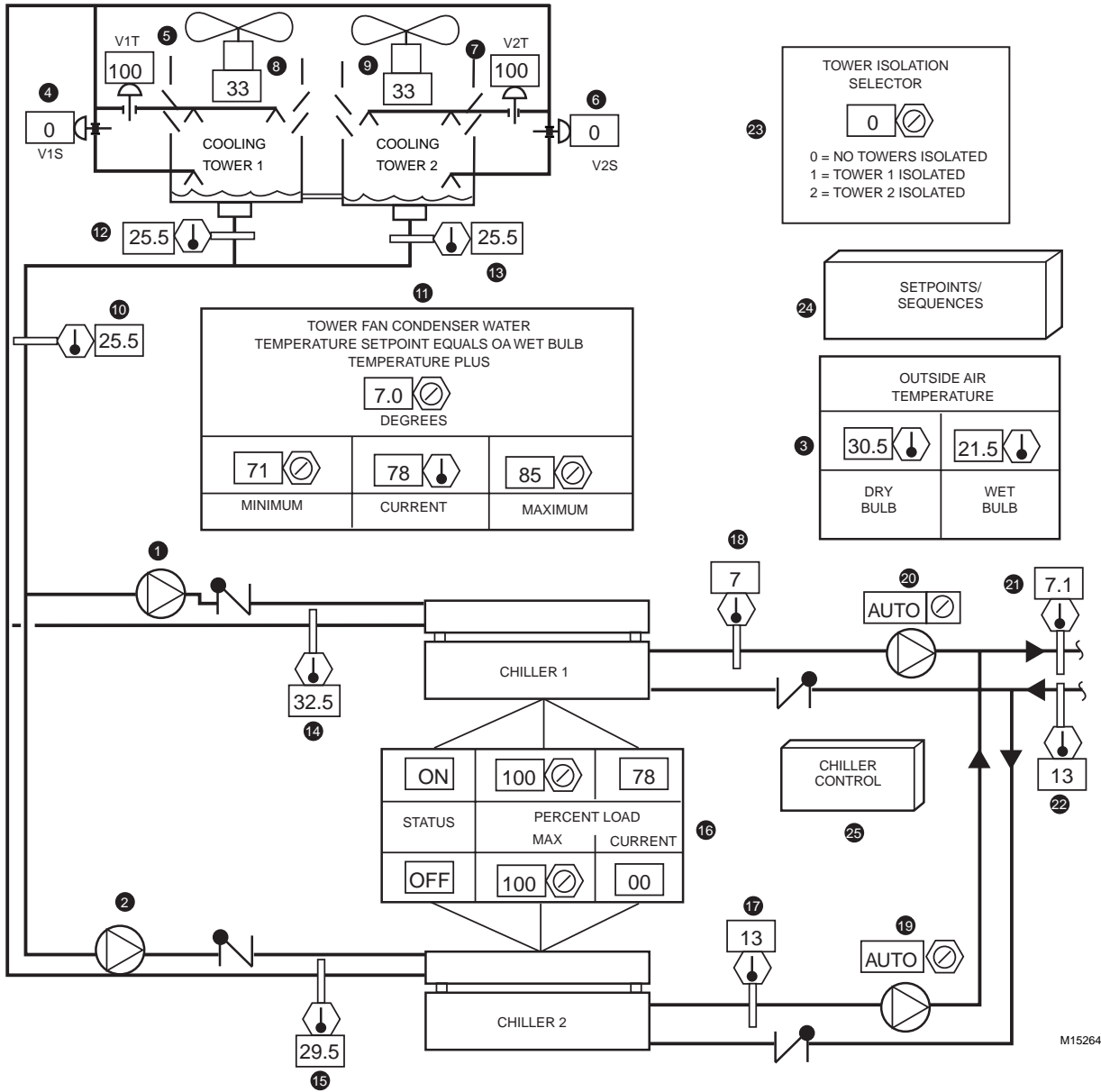

Fig. 31. Dual Cooling Tower Variable Speed Fan Control Graphic

Item No.	Function
1,2	Dual dynamic pump symbols indicate pump operational status.
3	OA Conditions dictate freeze-protection and optimized setpoint control strategies.
4-7	Valves provide tower isolation, modulating low limit condenser water control when OA temperature is above freezing, and two position low limit operation when OA temperature is below freezing.
8,9	Indicates tower fans speed (percent).
10	Input for common condenser water temperature control.
11	Optimum condenser water temperature calculation based upon OA WB.
12-22	Operator information.
23	Isolates towers if required.
24	Icon, for dynamic control and setpoint display.
25	Icon to select tower low load control dynamic sequence display.

Features

1. Precise PI condenser water control above minimum load.
2. User friendly monitoring and adjustment.
3. Optimized condenser water temperature.
4. Freeze prevention cycle.
5. Fan motor light-load over-heating protection.

Conditions For Successful Operation

1. Control network, software, and programming to advise tower controller of chiller demands.
2. Interlock and control wiring coordinated with the chiller manufacturer.
3. Good OA RH sensor and WB calculation.
4. Proper project specific setpoint and parameter settings
5. Electrical heaters and insulation on tower piping where water cannot drain when the tower is isolated or when the pump stops, if required.
6. Towers operate satisfactorily down to 50% water flow.
7. The common tower water temperature sensor has a high responsiveness and is in a well with heat conductive compound to rapidly detect temperature variations.
8. Chiller or free cooling HX tolerates variations in condenser water temperature when OA temperature is below freezing and fans and valves are cycling under temperature differential control and valves are not modulated because of freezing danger.
9. Common piping from chillers to cooling towers.

Specification

The dual variable speed fan cooling tower control configuration requires consideration of four control strategies:

- Single pump operation, above freezing OA.
- Single pump operation, below freezing OA.
- Dual pump operation, above freezing OA.
- Dual pump operation, below freezing OA.

NOTES:

1. If the towers are not required to operate when OA is suitable for air-side economizer cooling (usually below 14 or 14.5°C), leave the fans running at minimum speed (rather than switching to an on-off algorithm) and modulate the sump valves when necessary to prevent cooling to a temperature unacceptable to the chiller.
2. With both towers activated, the differentials used for cycling fans and valves are half of the differentials used when only one pump and tower are activated because only half the water is affected by the change.

Tower valves:

Each tower supply piping shall be provided with two modulating butterfly control valves; one normally open valve in the supply to the tower header, and one normally closed valve in a line to the tower sump. The valves shall operate inversely during temperature control modes. When both pumps are off, both valves shall open (to drain as much water as possible to tower sump), and both shall close during respective periods of tower isolation.

Condenser water set point calculation:

During chiller operation, the common condenser water temperature setpoint shall be reset to a value equal to the OA WB plus 3.5 kelvins, but to no lower than the chiller can tolerate and no higher than 29.5°C. During tower free cooling mode, the

setpoint shall be determined by the tower free cooling control module. The OA WB shall be calculated from OA RH (the RH sensor shall be of no less than 2% accuracy) and OA DB. The fans shall operate at the setpoint but no cooler than the minimum temperature the chiller can tolerate plus 1 kelvin. The valves shall operate to maintain a fixed minimum temperature setpoint of the minimum value the chiller can tolerate or the tower free cooling setpoint in the tower free cooling mode of operation.

Single pump operation with above freezing OA temperature:

For both towers; valves shall position open to the tower and closed to the sump and the tower fans shall modulate in unison under EPID control down to a minimum fan speed of 25% to maintain common condenser water temperature. If the condenser water load drops below the capacity of both fans operating at minimum speed, the fan that has operated longest shall stop and both its valves shall close, and the remaining tower fan shall assume the full load. If the condenser water load drops below the capacity of the remaining fan operating at minimum speed, the fan shall stop and revert to an on-off algorithm. In the on-off mode the fan shall stop at the fan control setpoint noted, the tower fan that has been off the longest shall restart after a rise in temperature of 3 kelvins, but to no higher than 29.5 °C and shall run no less than 7 minutes. The operating tower valves shall modulate to maintain the common condenser water setpoint at anytime regardless of fan operation. If, after running greater than 4 minutes in the on-off mode of operation, the water temperature rises to a value equal to the “fan on” setpoint plus 1 kelvin, the fan shall revert back to EPID control with a start value of 25% and a ramp duration of 120 seconds. If only one fan is running in the EPID control mode and its speed rises to 80 percent, the off tower valves shall position open to the tower and the off tower fan shall start at 25 percent speed and ramp into unison control over a 240 second duration.

Single pump operation with below freezing OA temperature:

This mode of fan operation shall be the same as for above freezing, except that the valve control algorithm must be two position (because modulating the tower water at below freezing OA temperatures can cause ice formation). Thus the valves shall position to full flow to the tower sump anytime the water temperature drops to the valve control setpoint, and shall position back to full flow to the tower after the water temperature has risen a value that resets from 3 to 6 kelvins as the OA temperature varies from 0°C to –18°C. The tower fan shall not be allowed to start until the valves have been positioned open to the tower greater than 90 seconds and the water temperature is rising.

Dual pump operation with above freezing OA temperature:

For both towers; valves shall position closed to the sump and the tower fans shall modulate in unison, to maintain a common condenser water temperature setpoint, under EPID control down to a minimum speed of 25%. If the condenser water load drops below the capacity of both fans operating at minimum speed, the fan that has operated longest shall stop, and the remaining tower fan shall assume the full load. If the condenser water load drops below the capacity of the remaining fan operating at minimum speed, the fan shall stop and revert to an on-off algorithm alternating the fans operating at the minimum speed in the “on” mode. In the on-off mode the fan shall stop at the fan control setpoint noted above, and shall restart after a rise in temperature of 2 kelvins, but to no higher than 29.5°C, and shall run no less

than 7 minutes. The operating tower valves shall modulate to maintain the above noted valve control setpoint at anytime regardless of fan operation. If, after a fan is running greater than 4 minutes in the on-off mode of operation, the water temperature rises to a value equal to the “fan on” setpoint plus 1 kelvin, the fan shall revert back to EPID control with a start value of 25% and a ramp duration of 120 seconds. If the single fan operates to a speed exceeding 60%, the “off” fan shall start at an initial speed of 25% and shall ramp into unison control over a 240 second duration (during which time the operating fan will slow down as the starting fan slowly assumes part of the load).

Dual pump operation with below freezing OA temperature:

For both towers; valves shall position closed to the sump and the tower fans shall modulate in unison, to maintain common condenser water temperature, under EPID control down to a minimum fan speed of 25%. If the condenser water load drops below the capacity of both fans operating at minimum speed, the fan that has operated longest shall stop, and the remaining tower fan shall assume the full load. If the condenser water load drops below the capacity of the remaining fan operating at minimum speed, the fan shall stop and revert to an on-off algorithm alternating the two tower fans operating at minimum speed in the “on” mode. In the on-off mode the fan shall stop at the fan control setpoint noted above, and shall restart after a rise in temperature of 2 kelvins, but to no higher than 29.5°C, and shall run no less than 7 minutes. If either fan is on and the water temperature drops to the valve control setpoint plus 0.5 kelvins, the valves of the tower in which the fan is on shall position open to the sump until the fan stops, at that time the valves shall position back to the tower.

If both fans are off and the water temperature drops to the valve control setpoint plus 0.5 kelvins, the valves of Tower 1 shall position open to the sump, and the Tower 2 valves shall alternately cycle open to the sump with a 1.5 kelvins temperature differential. If, while one valve is open to the sump, the water temperature drops to the valve control setpoint, the other valve shall position open to the sump, and the valves shall alternate open to the tower with a 1.5 kelvins differential. If, after one valve is open to the tower for 2 minutes, and the water temperature rises above the valve control setpoint plus 2 kelvins, the remaining valve shall position open to the tower and the valves shall revert to alternately opening to the sump at the valve control setpoint plus 0.5 kelvins, and opening to the tower after a 1.5 kelvins differential. If, after both valves position open to the tower for 2 minutes, the temperature rises to the valve control setpoint plus 2 kelvins, control shall revert back to alternately cycling the fans on at minimum speed as before. If, after a fan is running greater than 2 minutes at minimum speed in the on-off mode of operation, the water temperature rises to a value equal to the “fan on” setpoint plus 1 kelvins, the fan shall revert back to EPID control with a start value of 25% and a ramp duration of 120 seconds. If the single fan operates to a speed exceeding 60% for greater than 3 minutes, the “off” fan shall start at an initial speed of 25% and shall ramp into unison control over a 120 second.

NOTE: This “Dual pump below freezing OA temperature” sequence gets quite complex as the condenser water load increases and decreases. Table 1 may help understand the shifting sequence.

Table 1. Temperature Control Sequence for Dual Pumps Running in Below Freezing OA.

Load:	Load Sequence	
	Decreasing	Increasing
Between both fans running at minimum speed and full load.	Seq. 1: Modulates both fans in unison to control at Setpoint + 1 kelvin.	—
Less than both fans at minimum speed, greater than one fan at minimum speed.	Seq. 2: Fan running longest stops. Remaining fan modulates to maintain Setpoint + 1 kelvin.	Seq. 10: If one fan runs greater than 60% speed greater than 2 minutes: Remaining fan ramps on in unison from 25% speed over 240 seconds. Revert to Seq. 1.
Less than one fan at minimum speed, greater than both fans Off.	Seq. 3: Fans alternately cycled: At Setpoint + 2.5 kelvin first fan On at minimum speed. At Setpoint + 1 kelvin first fan Off. Fans run 6 minutes minimum. Repeat cycle for second fan.	Seq. 9: If either fan is on at minimum speed greater than 2 minutes & water temperature is greater than Setpoint + 2 kelvin: Revert to Seq. 2 via EPID with start value of 25% and ramp duration of 120 seconds.
One fan running at minimum speed greater than 2 minutes and water temperature less than Setpoint + 0.5 kelvin.	Seq. 4: Positions valve set of the operating tower to sump until fan stops. Repositions valve set back to tower.	—
Both fans Off greater than 2 minutes & water temperature less than Setpoint + 0.5 kelvin.	Seq. 5: Alternately positions valve sets: At Setpoint + 0.5 kelvin to sump. At Setpoint + 1.5 kelvin back to tower (one set of valves always open to tower). Fans locked Off.	Seq. 8: If both valve sets position open to the tower greater than 2 minutes & water temperature is greater than Setpoint + 2 kelvin: Revert to Seq. 3.
One set of valves open to tower (Seq. 5) greater than 2 minutes, & water temperature less than Setpoint.	Seq. 6: At setpoint positions valve sets of both towers to sump. At Setpoint + 1.5 kelvin alternately positions valve sets to tower (one set of valves always closed to sump).	Seq. 7: If one valve set positions open to the tower greater than 2 minutes & water temperature greater than Setpoint + 2 kelvin: Revert to Seq. 5.

CHILLER HEAT RECOVERY SYSTEM

A chiller heat recovery system uses heat rejected from a chiller to satisfy a simultaneous heating load. To accomplish this the heating water design temperature becomes the condenser water design temperature for the chiller. A typical simultaneous cooling and heating load includes an interior zone cooling load and a perimeter zone heating load. When the cooling load is greater than the heating load, the excess heat is dissipated in a cooling tower. The control strategy is to use as much heat as needed from the condenser and to reject excess heat to the cooling tower when necessary.

Figure 32 shows a heat recovery system and control sequence for a cooling system with one chiller and a double bundle condenser where chiller capacity is controlled from the chilled water supply temperature. The double bundle condenser uses heat recovery water or cooling tower water or both to cool refrigerant. Cooling tower water cannot be mixed with heat recovery water so the two systems must be isolated. In a single chiller system, the control system checks the water temperature coming out of the heat recovery bundles (T3). If it is warmer than the water returning from the heating loads (T2), valve V1 opens to circulate condenser water through the system. A hot water generator (boiler or converter) provides additional heat as required. If the heat recovery system is not cooling the condenser sufficiently, the cooling tower is used to dissipate excess heat. In multiple chiller systems, the heat recovery chiller is controlled by the heating load (T1). The other chillers provide additional cooling as required.

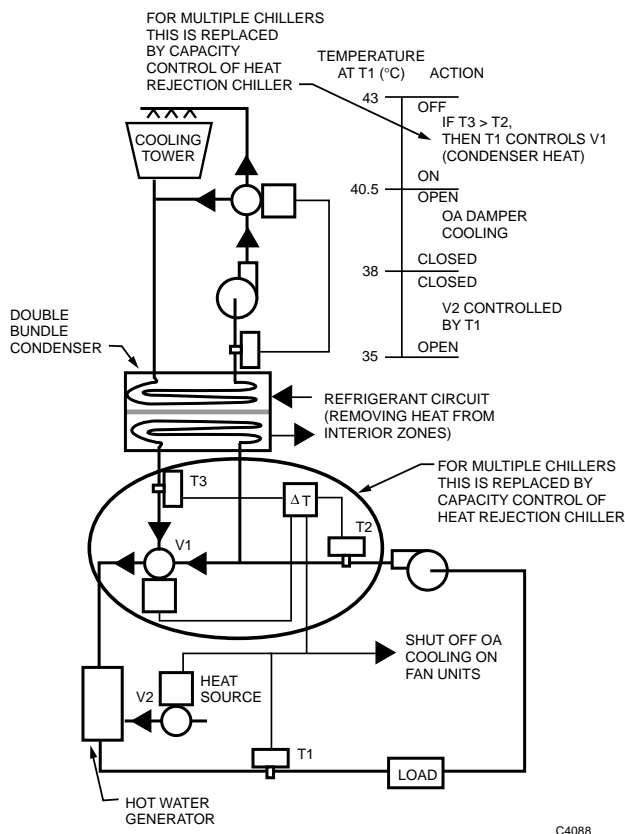

Fig. 32. Heat Pump Cycle Controls and Sequence.

If chilled water reset is used, stop the reset action when the cooling tower is off. This provides recovery system heat to a lower outdoor temperature before it is necessary to use fuel for heating.

FREE COOLING-TOWER COOLING

When the condenser water temperature from an evaporative cooling tower is equal to or lower than chilled water load requirements, mechanical refrigeration is not needed. During these times “free cooling” from the evaporative cooling tower is available without having to supply energy to the compressor. Figures 33, 34, and 35 show three methods of providing tower cooling to the chilled water circuit.

In refrigerant vapor migration (Fig. 33) two refrigerant paths with migration valves are added between the condenser and the evaporator. The paths bypass the compressor and allow gravity flow of liquid refrigerant from condenser to evaporator and vapor flow from evaporator to condenser. Refrigerant vaporizes in the evaporator and migrates to the condenser where it is condensed by cooling tower water. The liquid then flows back to the evaporator by gravity. The chiller must be designed so the flow paths are unrestricted and the evaporator is lower than the condenser. The bypass valves are normally included as a chiller package option by the manufacturer.

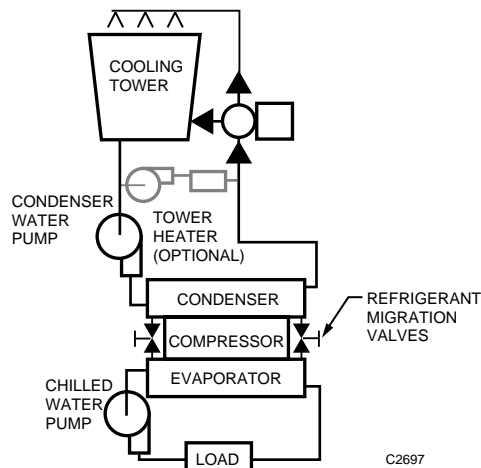

Fig. 33. Free Cooling Using Refrigerant Vapor Migration.

In Figure 34, condenser and chilled water flows are diverted from the chiller to a heat exchanger.

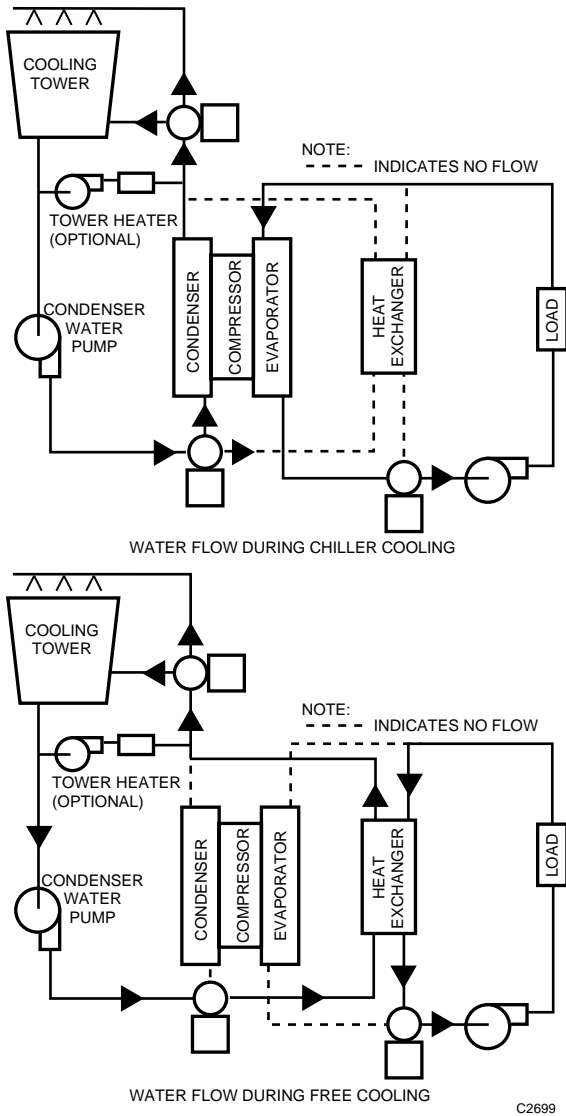

Fig. 34. Free Cooling Using Auxiliary Heat Exchanger.

In Figure 35, condenser and chilled water circuits are interconnected bypassing the chiller. In this configuration providing tower water treatment and filtering and pumping capacity for proper cooling tower flow are major considerations.

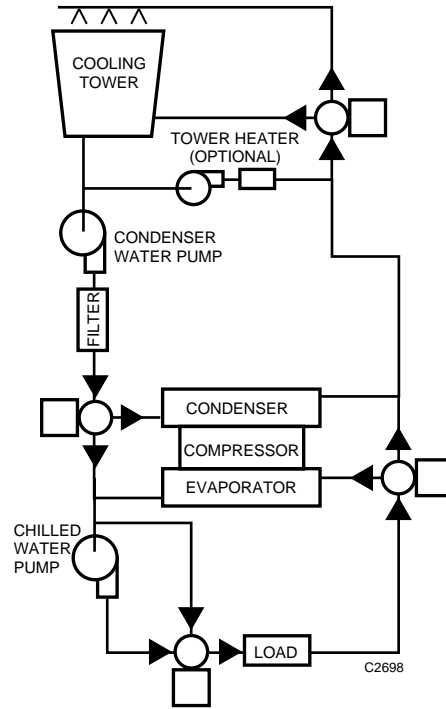

Fig. 35. Free Cooling by Interconnecting Water Circuits.

When the chiller is shut down during free cooling operation, the normal chilled water supply temperature control is bypassed and the chilled water supply temperature is determined by the tower water temperature. The normal cooling tower water control cycles tower fans and modulates the tower bypass valve to maintain a setpoint in the 18°C to 29.5°C range but cooling tower water is controlled at 1.5°C to 7°C when used directly for cooling.

During free cooling the fans may be manually turned on if there is no danger of supply water being too cold or too much energy being used by a winterized cooling tower. However, if either condition exists, the tower water temperature control should be in operation at all times to maintain a free cooling temperature of 1.5°C to 7°C.

The changeover from free cooling to chiller operation may be manual or automatic. Changeover sequence should change the tower water controller setpoint first, then change the heat exchanger valves when temperatures are proper for the new mode of operation.

Following is a tower-free-cooling example using plate-frame heat exchangers for the dual chiller system shown in the DUAL CENTRIFUGAL CHILLER example. The DUAL COOLING TOWER VARIABLE SPEED FAN CONTROL example is also relevant.

TOWER FREE COOLING, DUAL CHILLERS

FUNCTIONAL DESCRIPTION

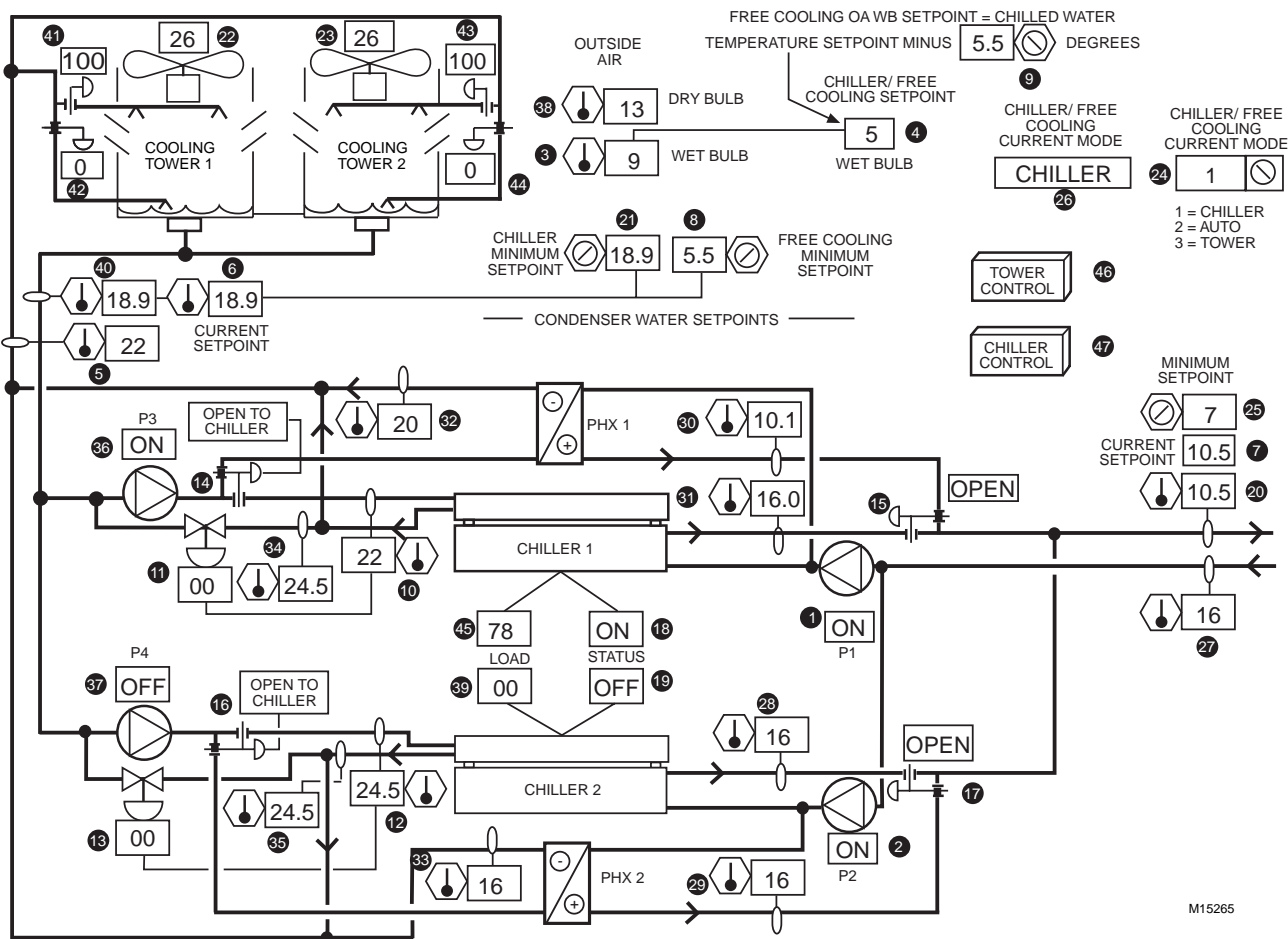

Fig. 36. Graphic for Tower Free Cooling System with Dual Chillers.

Item No.	Function		
1,2	Chilled water pumps produce flow through chillers or plate/frame heat exchangers.		water temperature down to free cooling setpoint value and the temperature is too low for chiller.
3,4	Free cooling mode initiated when OA WB drops to setpoint.	14-17	Valves direct water from chiller/condenser to HX when condenser water reaches setpoint.
5	Tower water entering temperature, operator information.	18,19 20	Chiller Status. Operator information.
6,7	Setpoints indicate need for cooling tower and chilled water.	21	Prevents tower from cooling water below minimum value that chiller can tolerate (during chiller cooling mode).
8	Minimum condenser water temperature setpoint provides free cooling low limit.	22,23	Tower fans modulate to maintain condenser water setpoint.
9	In free cooling mode, tower will produce water about 4 kelvins above OA wet-bulb temperature, and HX will cool chilled water to within 1 to 1.5 kelvins of condenser water temperature, so the sum of these dictates when to activate free cooling.	24 25	CHILLER-AUTO-TOWER software mode selection function. Prevents chilled water temperature setpoint from dropping below the design minimum.
10-13	Maintains condenser water temperature entering chiller during period when tower is pulling	26-45 46 47	Operator information (see chiller control and cooling tower control examples). Icon, to display cooling tower control data. Icon, to display chiller control data.

Features

1. Production of chilled water via condenser water and a HX in lieu of chiller operation.
2. User friendly monitoring and adjustment.
3. Automatic selection of free cooling mode.
4. Maintains full flow and minimum temperature condenser water during free cooling pull-down period.

Conditions For Successful Operation

1. Control network, software, and programming to advise chilled water plant of AHU chilled water demands.
2. Interlock and control wiring coordinated with the chiller manufacturer.
3. Appropriate cooling tower and chiller control.
4. Accurate calculation of OA WB from OA DB and OA RH.
5. Pumps selected for HX pressure drops and chiller/condenser water flow balancing.
6. Flow switches and starter auxiliary contacts provided to prove flow in lieu of current sensing relays for the chiller and condenser pumps.

Specification

NOTE: This control scheme assumes that the chilled water plant must continue to operate while the condenser water temperature is dropped from the minimum temperature acceptable to the chiller to the temperature required to produce chilled water. It is also assumed that full condenser water flow is required at all times (otherwise, chiller pressure could be maintained by modulating the tower-side changeover valves to reduce condenser flow).

Chilled water pump:

Anytime at least one chilled water pump is operating and the OA WB drops below the free cooling setpoint for greater than ten minutes, the condenser water temperature setpoint shall be lowered to a value equal to the chilled water setpoint minus 1.5K, but no lower than 5.5°C. The OA WB free cooling changeover setpoint shall be the chilled water temperature setpoint minus 5 kelvins.

Condenser water:

During the condenser water temperature pull-down period, the condenser entering water temperature shall be prevented from dropping below the minimum acceptable value by modulating open a valve between the condenser leaving water and the pump inlet.

When the condenser water temperature reaches the free cooling setpoint, the changeover valves for the chiller that has operated longest shall position open to the HX and the chiller shall stop. If the free cooling condenser water temperature setpoint is not reached within eight minutes, the condenser water setpoint shall be returned to the chiller cooling value and a descriptive system alarm shall be issued.

Five minutes after the first chiller changes over to free cooling, the second chiller shall changeover as noted for the first chiller.

In the free cooling mode, the tower controls shall operate to maintain the condenser water temperature setpoint, which shall be reset from 5.5°C to 13.5°C by the chilled water temperature setpoint demand for cooling.

Anytime the system is running in the free cooling mode and the chilled water temperature is greater than 1 degree above setpoint for greater than 5 minutes, the changeover valves for the chiller that has been off longest shall position open to the chiller, the condenser water temperature setpoint shall be raised to the value specified for chiller operation, and the chiller controls shall be enabled. If both chilled water pumps are operating, the remaining chiller shall changeover and start 2 minutes later. As the chillers start, their respective low-limit condenser water temperature valves shall be placed under EPID control with a start value of 75% open and a ramp duration of 60 seconds.

After reverting back to the chiller cooling mode, during the condenser water warm-up period the cooling tower fans shall remain on at no less than minimum speed, to prevent short cycling, and the condensers entering water temperature shall be controlled by the low-limit condenser water temperature pump inlet valves.

A software CHILLER-AUTO-TOWER selection function shall be provided to lock the system in either mode if desired.

BOILER SYSTEM CONTROL

INTRODUCTION

A boiler is a closed vessel intended to heat water and produce hot water or steam through combustion of a fuel or through the action of electrodes or electric resistance elements. Steam and hot water boilers are available in standard sizes from very small boilers for apartments and residences to very large boilers for commercial and industrial uses.

BOILER TYPES

Boilers are classified by water temperature or steam pressure. They are further classified by type of metal used in construction (cast iron, steel, or copper), by type of fuel (oil, gas, or electricity), or by relationship of fire or water to the tubes (firetube or watertube).

- Low-pressure boilers are those designed to produce steam up to 200 kPa or hot water up to 120°C with pressures up to 1200 kPa.
- Medium and high pressure boilers produce steam above 200 kPa or hot water above 1200 kPa or 120°C or both.

CAST IRON AND STEEL BOILERS

Boilers are typically constructed of cast iron or welded steel. Cast iron boilers (Fig. 37) are made of individually cast sections and are joined using screws or nuts and tie rods or screwed nipples to join sections. The number of sections can be varied to provide a range of capacities.

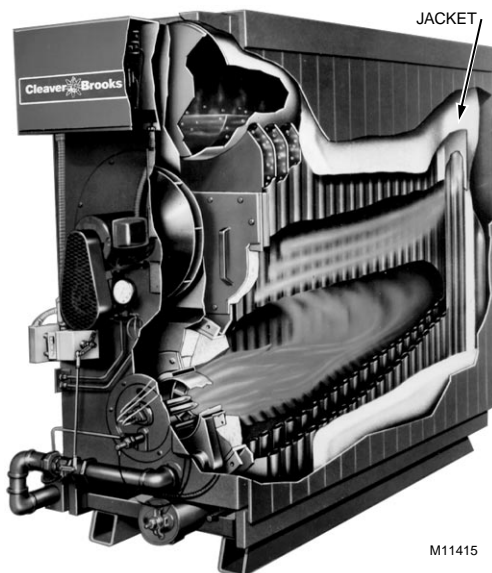

Photo Courtesy of Cleaver Brooks
Fig. 37. Typical Cast Iron Boiler (Watertube).

Steel boilers come in a large variety of configurations. They are factory assembled and welded and shipped as a unit. Figure 38 illustrates a firetube boiler. The fire and flue gases are substantially surrounded by water. The products of combustion pass through tubes to the back then to the front and once more to the back before finally exiting at the front. This makes it a four-pass boiler. Firetube boilers are manufactured in many other configurations such as:

- External firebox, firebox not surrounded by water.
- Dry back, firetubes directly available from clean-out doors at back of boiler.
- Scotch-Marine, low water volume and fast response.

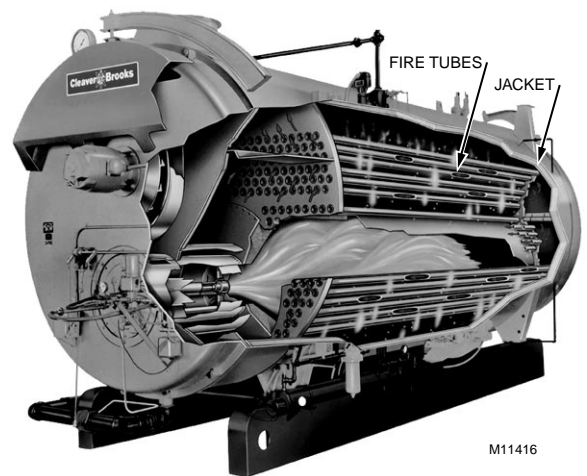

Photo Courtesy of Cleaver Brooks
Fig. 38. Typical Firetube Boiler.

Watertube boilers are steel body boilers used for high capacity requirements of more than 590 kW. Watertube boilers use a water-cooled firebox which prolongs the life of furnace walls and refractories.

MODULAR BOILERS

Modular boilers are small hot water boilers rated at 60 kW to 260 kW input. These boilers are available with 85 percent or higher gross efficiency. Figure 39 shows features of a typical modular boiler. These boilers are often used in tandem to provide hot water for space heating and/or domestic hot water. For example, if the design heating load were 600 kW, four 180 kW (input) modular boilers might be used. If the load were 25 percent or less on a particular day, only one boiler would fire and cycle on and off to supply the load. The other three boilers would remain off with no water flow. This reduces flue and jacket (covering of the boiler) heat losses.

Some modular boilers have very small storage capacity and very rapid heat transfer so water flow must be proven before the burner is started.

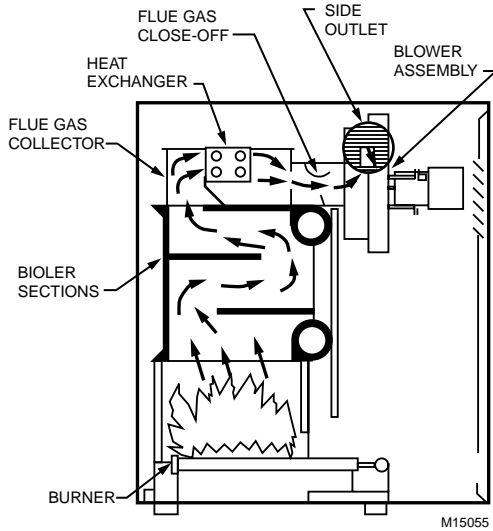

Fig. 39. High Efficiency Modular Boiler.

Electric elements and electrodes are grouped to provide four or more stages of heating. A step controller responding to steam pressure or hot water temperature activates each stage of heating as required to heat the building.

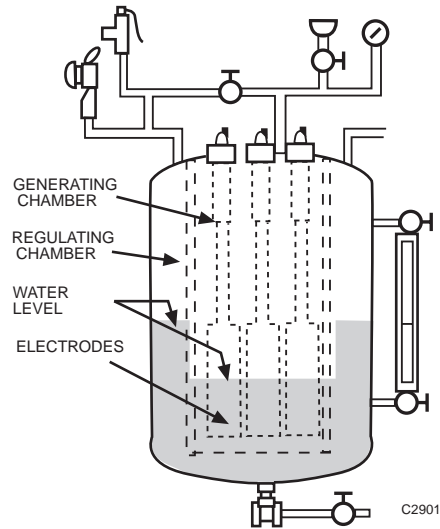

Fig. 40. Electrode Steam boiler.

ELECTRIC BOILERS

Electric boilers heat water or produce steam by converting electrical energy to heat using either resistance elements or electrodes. Electric boilers are considered to be 100 percent efficient since all power consumed, directly produces hot water or steam. Heat losses through the jacket and insulation are negligible and there is no flue.

Electrode boilers (Fig. 40) have electrodes immersed in the water. Current passes through the water between electrodes and the resistance of the water generates heat. Electrode boilers are available in sizes up to 11,000 kW. Resistance boilers have the resistance (heating) elements immersed in but electrically insulated from the water and are manufactured in sizes up to 3000 kW.

BOILER RATINGS AND EFFICIENCY

Boilers can be rated in several ways. Figure 41 shows commonly used ratings and terms. Boiler input rate is in kilowatts (kW). Input ratings are usually shown on the boiler (or burner) nameplate. The boiler output rate is given in grams per second (g/s).

Gross efficiency is output (steam or water heat content and volume) divided by fuel input (measured by a fuel meter at steady-state firing conditions). The efficiency as indicated by flue gas conditions does not take into account jacket and piping losses so is usually higher than the gross efficiency.

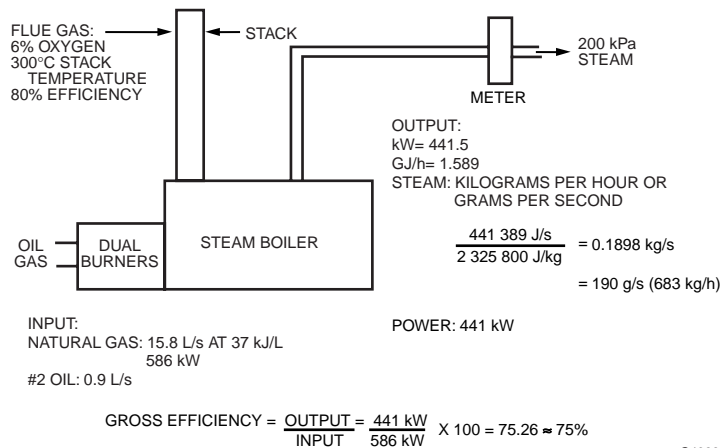

Fig. 41. Boiler Ratings and Efficiency.

COMBUSTION IN BOILERS

PRINCIPLES OF COMBUSTION

When gas, oil, or other fuels are burned, several factors must be considered if the burning process is to be safe, efficient, and not harmful to the environment. The burning process must:

1. Provide enough air so that combustion is complete and undesirable amounts of carbon monoxide or other pollutants are not generated.
2. Avoid excess air in the fuel-air mixture which would result in low efficiency.
3. Provide complete mixing of air with fuel before introducing the mixture into the firebox.
4. Provide safety controls so that fuel is not introduced without the presence of an ignition flame or spark and that flame is not introduced in the presence of unburned fuel.
5. Avoid water temperatures below the dewpoint of the flue gas to prevent condensation on the fireside of the boiler.

FLUE GAS ANALYSIS

Combustion can be monitored by flue gas analysis. For large boilers, over 300 kW, the analysis is typically continuous. For small boilers, flue gas is analyzed periodically using portable instruments.

Flue gas composition analysis routinely measures the percent of CO₂ (carbon dioxide) or O₂ (oxygen), but not both. Ideal CO₂ is in the 10 to 12 percent range. Percent oxygen is the most reliable indication of complete combustion. The ideal O₂ concentration is in the three to five percent range. Lower concentrations are impractical and often unsafe. Higher O₂ concentrations mean that an excessive quantity of air is admitted to the combustion chamber and must be heated by the fuel. This excess air passes through the boiler too quickly for the heat to be efficiently transferred to the water or steam. Carbon dioxide measuring instruments are simpler or lower cost than O₂ measuring instruments.

The CO₂ or O₂ concentration plus stack temperature provide a burner efficiency in percent either directly or by means of charts. This efficiency indicates only the amount of heat extracted from the fuel. It does not account for excess heating of combustion air or losses from leaks or the boiler jacket.

OIL BURNERS

Oil burners are usually of the atomizing variety, that is, they provide a fine spray of oil. Several types exist:

- Gun type burners spray oil into a swirling air supply.
- Horizontal rotary burners use a spinning cup to whirl oil and air into the furnace.

- Steam or air atomizing burners use high pressure air or 270 kPa steam to break up the oil into fine droplets.

For modulating or high/low flame control applications the rotary or steam/air atomizing burners are most common.

GAS BURNERS

Two typical types of gas burners are the atmospheric injection burner and the power type burner. The atmospheric injection burner uses a jet of gas to aspirate combustion air and is commonly used in home gas furnaces and boilers. The raw-gas ring burner (Fig. 42) is an atmospheric injection burner.

Power burners (Fig. 43) use a forced-draft fan to thoroughly mix air and gas as they enter the furnace. They are common in commercial and industrial applications.

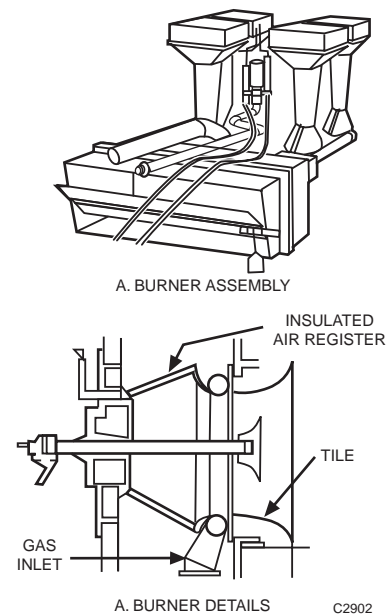

Fig. 42. Raw Gas Ring Burner.

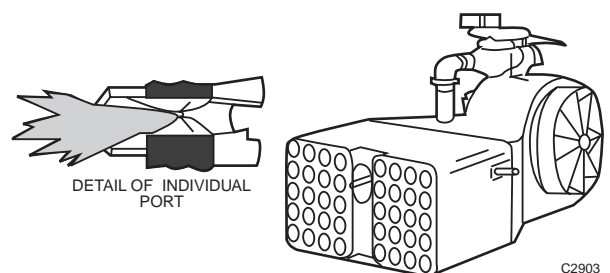

Fig. 43. Multiport Forced-Draft Gas Burner.

BOILER CONTROLS

BOILER OUTPUT CONTROL

There are three ways to control the output of a commercial boiler:

1. On-off (cycling) control.
2. High-fire, low-fire control.
3. Modulating control.

On-off (cycling) control is most common for small boilers up to 300 kW capacity. The oil or gas burner cycles on and off to maintain steam pressure or water temperature. Cycling control causes losses in efficiency because of the cooling of the fireside surfaces by the natural draft from the stack during the off, prepurge, and postpurge cycles necessary for safety.

High-fire, low-fire burners provide fewer off cycle losses since the burner shuts off only when loads are below the low-fire rate of fuel input.

Modulating control is used on most large boilers because it adjusts the output to match the load whenever the load is greater than the low-fire limit, which is usually not less than 15 percent of the full load capacity. Steam pressure or hot water temperature is measured to control the volume of gas or oil admitted to the burner.

Boiler firing and safety controls are boiler manufacturer furnished and code approved. A BMCS usually enables a boiler to fire, provides a setpoint, controls pumps and blending valves, and monitors alarms and operation.

COMBUSTION CONTROL

Combustion control regulates the air supplied to a burner to maintain a high gross efficiency in the combustion process. More sophisticated systems use an oxygen sensor in the stack to control the amount of combustion air supplied. Smoke density detection devices can be used in the stack to limit the reduction of air so stack gases stay within smoke density limits. A continuous reading and/or recording of flue gas conditions (percent O₂, stack temperature) is usually included in the control package of large boilers.

A simple combustion control system contains a linkage that readjusts the air supply from the same modulating motor that adjusts fuel supply (Fig. 44). There may be a provision to stop flow of air through the fluebox during the off cycles.

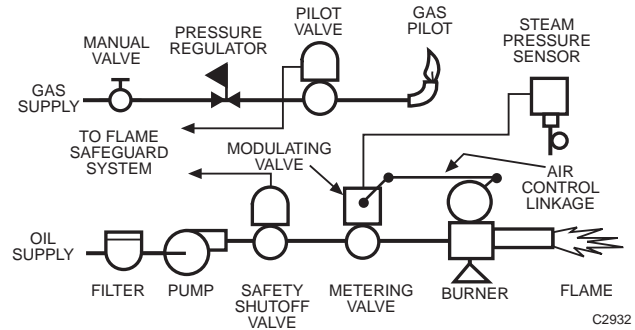

Fig. 44. Combustion Control for Rotary Oil Burner.

FLAME SAFEGUARD CONTROL

Flame safeguard controls are required on all burners. Controls for large burners can be very complicated while controls for small burners such as a residential furnace are relatively simple. The controls must provide foolproof operation, that is, they must make it difficult or impossible to override any of the safety features of the system. The controls also should be continuous self check. For commercial and industrial burners, the flame safeguard control goes through a series of operations. The following sequence is an example:

- Purge firebox of unburned fuel vapor (prepurge).
- Light pilot.
- Verify that pilot is lit.
- Open main fuel valve.
- Verify that flame is present as soon as fuel is introduced.
- Cut off fuel supply promptly if the flame fails.
- Purge firebox of any unburned fuel after each on cycle (post-purge).

The key to any flame safeguard system is a reliable and fast means of detecting the presence or absence of a flame. Methods of detection are:

- Response of bimetal sensor to heat (slow response).
- Response of thermocouple to heat (slow response).
- Flame conductivity (fast but can be fooled).
- Flame rectification (fast, reliable).
- Ultraviolet flame detection (fast, reliable).
- Lead sulfide (photo) cells (fast, reliable if flame frequency check included).

Some sensors can potentially cause improper operation because of shorts, hot refractories, or external light sources. Other sensors, like flame rectification and ultraviolet, respond to flame only. Flame safeguard systems must be approved by UL or Factory Mutual for specific applications.

Figure 45 shows a flame safeguard system often applied to small gas boilers or furnaces. The flame of the gas pilot impinges on a thermocouple which supplies an electric current to keep the pilotstat gas valve open. If the pilot goes out or thermocouple fails, the pilotstat valve closes or remains closed preventing gas flow to the main burner and pilot. The pilotstat must be manually reset.

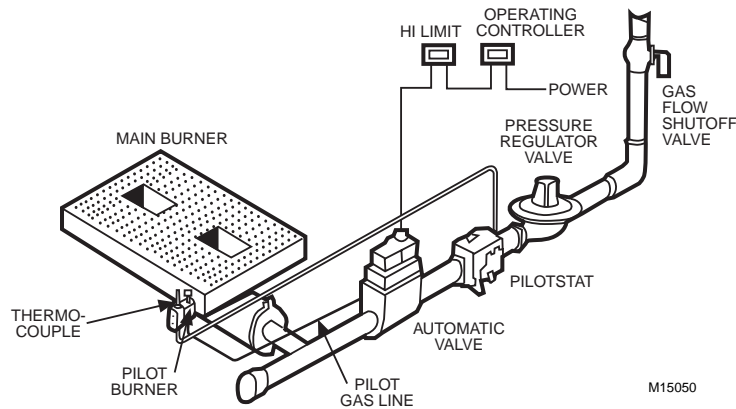

Fig. 45. Simple Flame Safeguard for a Gas Furnace.

Figure 46 shows how flame safeguard controls are integrated with combustion controls on a small oil fired steam boiler. The ultraviolet (UV) flame detector is located where it can see the flame and will shutdown the burner when no flame is present.

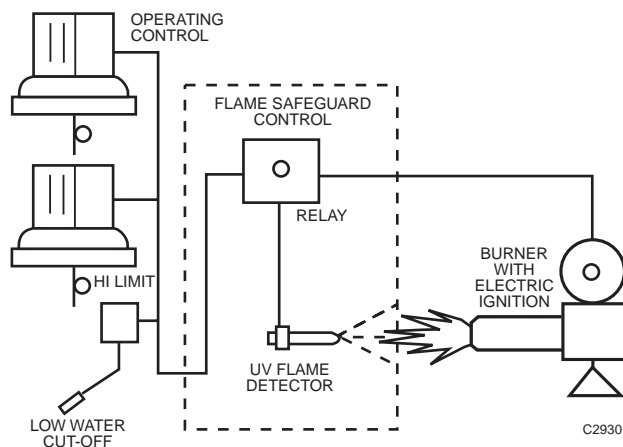

Fig. 46. Combustion Controls with Flame Safeguard Circuit.

APPLICATION OF BOILER CONTROLS

Boilers have to provide steam or hot water whenever heat is needed. A conventional BMCS is often set to provide a continuous hot water or steam supply between October and May at anytime the OA temperature drops to 16°C for more than 30 minutes and an AHU is calling for heat. The BCMS should include a software ON-OFF-AUTO function. Unlike chillers, boilers can be left enabled at no-load conditions, during which time the water temperature will be held at the design temperature. Frequent warm-up and shut-down of boilers causes stress buildup. Boiler manufacturers recommendations provide specific guidelines.

Unless a water temperature low limit is used, hot water boiler burners are not controlled to provide water temperatures based on outdoor temperatures because the reset schedules require water temperatures to be supplied below the dew point temperature of the flue gas. Some boilers require entering water temperatures to be above 60°C before going to high fire. In this case, if a building is using hot water and the boiler is locked into low-fire because the entering water is too cold, the system may never recover.

FLAME SAFEGUARD INSTRUMENTATION

In addition to the combustion, safety, and flame safeguard controls shown in Figure 46, additional instrumentation often provided on larger burners measures:

- Percent of O₂ or CO₂ in flue gas (to monitor combustion efficiency).
- Flue gas temperature.
- Furnace draft in inches of water column.
- Steam flow with totalizer or hot water flow with totalizer.
- Oil and/or gas flow with totalizer.
- Stack smoke density.

MULTIPLE BOILER SYSTEMS

GENERAL

Basic boiler connections for a three-zone hot water system are shown in Figure 47. In this system, two boilers are connected in parallel. Hot water from the top of the boilers moves to the air separator which removes any entrapped air from the water. The expansion tank connected to the separator maintains pressure on the system. The tank is about half full of water under normal operating conditions. Air pressure in the tank keeps the system pressurized and allows the water to expand and contract as system water temperature varies. Water from the boiler moves through the separator to the three zone pumps, each of which is controlled by its own zone thermostat. In some systems, each zone may have a central pump and a valve. Return water from the zones returns to the boiler in the return line. There several variations are possible with this type system but the process is the same. There is no minimum boiler water flow limit in this example.

The Dual Boiler Plant Control example following is a dual boiler plant with high-fire, low-fire controlled boilers, 63°C minimum entering water temperature required prior to high-fire, water flow must be maintained when the boiler is enabled, and a secondary hot water reset schedule of 43°C water at 13°C OA temperature and 82°C water at -15°C OA temperature. The concepts adapt well for single or multiple boiler systems.

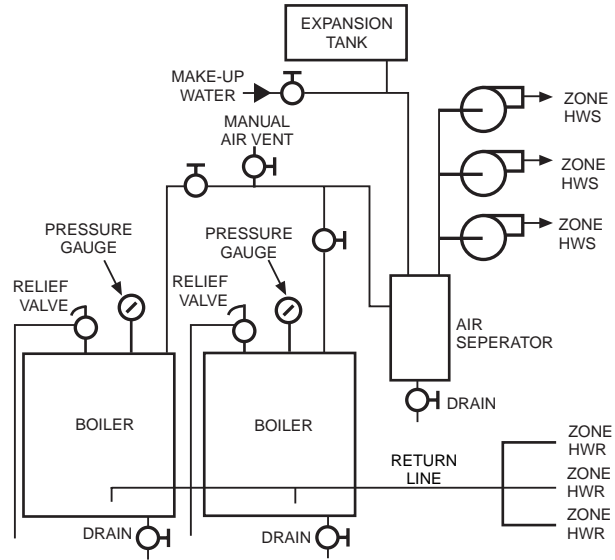

C2905

Fig. 47. Typical Piping for Multiple-Zone Heating System.

NOTE: The primary/secondary decoupler is sized for the full secondary flow, and like the chiller plant decoupler, should be a minimum of 6 pipe diameters in length. Unlike the chiller decoupler, normal flow may be in either direction.

DUAL BOILER PLANT CONTROL

FUNCTIONAL DESCRIPTION-

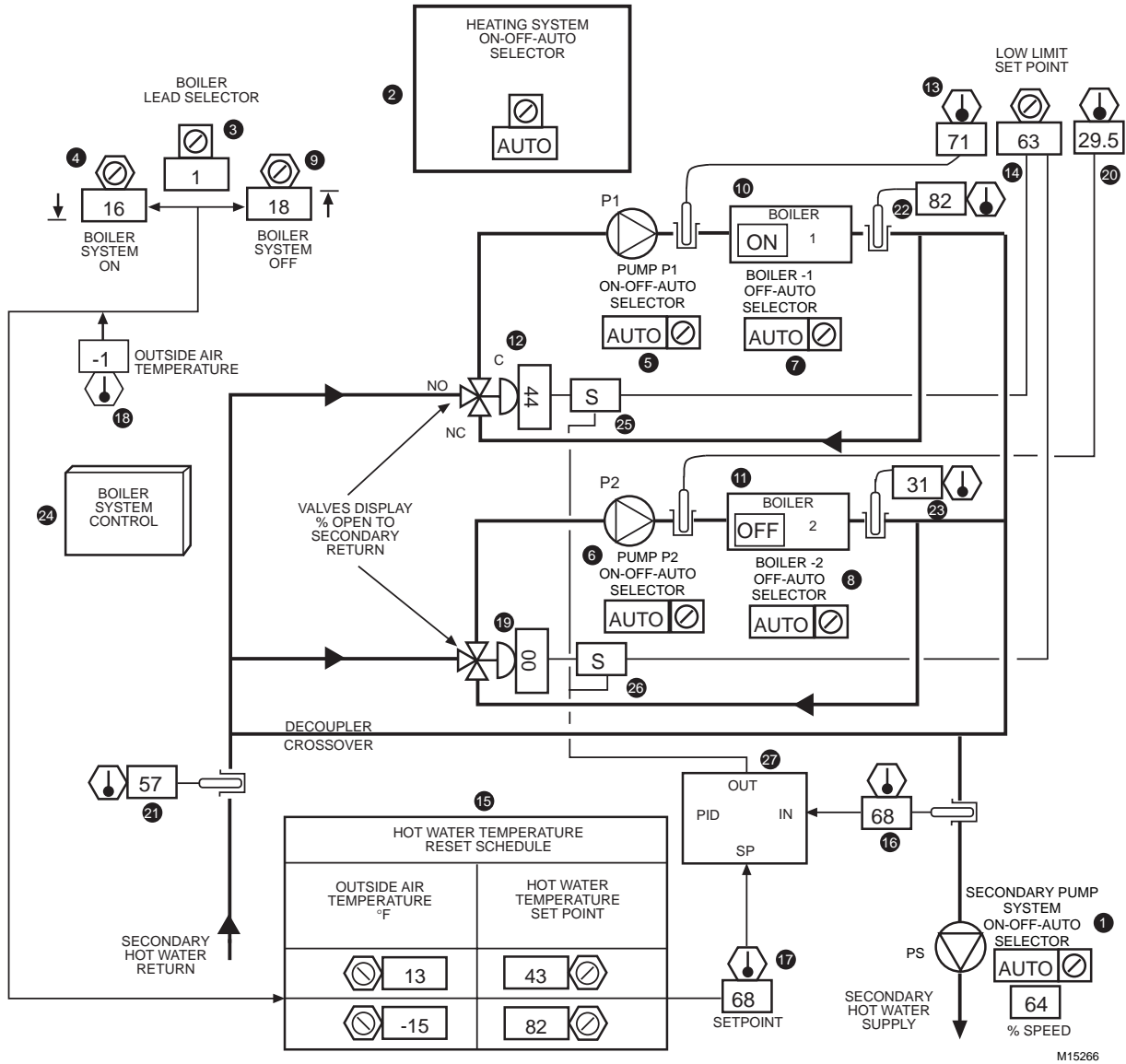

Fig. 48. Dual Boiler Plant Control Graphic

Item No.	Function		
1	ON-OFF-AUTO function for secondary pumping system	12-14	Valve modulates to prevent entering water from dropping below low limit setpoint (63°C).
2	ON-OFF-AUTO function for heating system	15-18	Secondary water setpoint reset from OA.
3	Selects lead boiler.	19,20	Valve modulates to prevent entering water from dropping below low limit setpoint (63°C).
4	Heating system start point (Outside air temperature).	21-23	Operator information.
5,6	ON-OFF-AUTO function for primary pumps.	24	Icon, selects the Boiler System Control dynamic display (Fig. 49).
7,8	OFF-AUTO function for boilers.		Software signal selection functions, allows valve to control secondary HW temperature, subject to boiler low limits.
9	Heating system stop point (Outside air temperature).	25,26	OA reset valve control PID.
10,11	Operator information.	27	

Features

- 1. Full flow through operating boilers.
- 2. Minimum temperature limit on boiler entering water.
- 3. Variable flow secondary system with full boiler flow.
- 4. Automatic boiler staging
- 5. User friendly monitoring and adjustment.

Conditions For Successful Operation

- 1. Control network, software, and programming to advise heating plant controller of secondary fan and water flow demands.
- 2. Interlock and control wiring coordinated with the boiler manufacturer.
- 3. Control in accord with boiler manufacturers recommendations.
- 4. Proper setpoint and parameter project specific settings.

Specification

The heating plant shall operate under automatic control anytime the secondary pump ON-OFF-AUTO function is not "OFF", subject to a heating system ON-OFF-AUTO software function. The lead boiler, as determined by a software lead boiler selection function, shall be enabled anytime the date is between October first and May first, the OA temperature drops below 16°C for greater than 30 minutes, and an AHU is calling for heat. Each boiler primary pump shall have a software ON-OFF-AUTO function, and each boiler shall have a software AUTO-OFF function. The heating plant shall be disabled anytime the OA temperature rises to 18°C for greater than 1 minute and after May 1.

Anytime the boiler plant is enabled, the lead boiler primary pump shall start and as flow is proven, the boiler shall fire under its factory controls to maintain 82°C. If the lead boiler status does not change to "on", or if flow is not proven within 5 minutes, the lag boiler shall be enabled.

BOILER SYSTEM CONTROL

A BLENDING VALVE ON EACH BOILER MODULATES IN THE RECIRCULATING POSITION TO PREVENT THE BOILER ENTERING WATER TEMPERATURE FROM DROPPING BELOW 63 DEGREES.

LEAD BOILER (1) AND ITS ASSOCIATED PUMP START ANYTIME THE OUTSIDE AIR TEMPERATURE DROPS TO 16 AND SHUTS DOWN ANYTIME THE OUTSIDE AIR TEMPERATURE RISES TO 18 DEGREES. ANYTIME THE LEAD BOILER STARTS FROM THIS OUTSIDE AIR TEMPERATURE SETTING, THE OTHER BOILER IS LOCKED OUT FOR 60 MINUTES.

ANYTIME THE LEAD BOILER CONTROL VALVE IS COMMANDED FULL OPEN BY THE SECONDARY WATER TEMPERATURE CONTROL LOOP FOR 5 MINUTES AND THE SECONDARY HOT WATER SUPPLY TEMPERATURE IS MORE THAN 2.5 KELVINS BELOW IT'S SETPOINT, THE LAG BOILER AND ITS ASSOCIATED PUMP START. ANYTIME BOTH BOILERS ARE OPERATING AND THEIR CONTROL VALVES ARE LESS THAN 40 PERCENT OPEN TO THE SECONDARY RETURN, THE BOILER SYSTEM OPERATING LONGEST SHUTS DOWN.

THE BOILER BLENDING VALVES MODULATE (SUBJECT TO THEIR LOW LIMIT CONTROL) TO PRODUCE SECONDARY WATER TEMPERATURES FROM 43 TO 82 DEGREES AS THE OUTSIDE AIR TEMPERATURE DROPS FROM 13 TO -15 DEGREES.

M15267

Fig. 49. Boiler System Control Dynamic Display.

During boiler operation, a three way blending valve shall position to place the boiler flow in a recirculating mode until the water entering the boiler exceeds a low limit value of 63°C, at which time the blending valve shall modulate to maintain the secondary water temperature between 43°C and 82°C as the OA temperature varies from 13°C to -15°C.

The lag boiler shall be locked out from operation for 60 minutes after the lead boiler starts. Thereafter, anytime one boiler control valve is commanded full open by the secondary temperature control loop for greater than 5 minutes and the secondary water temperature is a temperature less than 2.5 kelvins below the secondary water temperature setpoint, the “off” (lag) boiler pump shall start, and upon proving flow, the “off” boiler shall be enabled to fire under its factory controls to maintain 82°C. The just-started boiler blending valve shall be controlled by an entering water 63°C temperature low limit sensor and setpoint similar to the lead boiler, and subsequently, in unison with the other boiler blending valve to maintain the reset secondary hot water temperature.

Anytime both boilers are operating and their control valves are less than 40% open to the secondary return line, the boiler and pump that has run longest shall shut down.

MODULAR BOILERS

Modular boilers provide heat over a large range of loads and avoid standby and other losses associated with operating large boilers at small loads. Figure 50 shows a primary-secondary piping arrangement where each modular boiler has its own pump. The boiler pump is on when the boiler is on.

Boilers that are off have no flow and are allowed to cool. Each boiler that is on operates at or near full capacity. Avoiding intermittent operation prevents losses up the stack or to the surrounding area when the boiler is off.

Normal control of modular boilers cycles one of the on-line boilers to maintain water temperature in the supply main to meet load requirements. The supply main control sensor cycles the boilers in sequence. If the load increases beyond the capacity of the boilers on-line, an additional boiler is started. The lead (cycling) boiler can be rotated on a daily or weekly basis to equalize wear among all boilers or when using digital control, the program can start the boiler that has been off the longest.

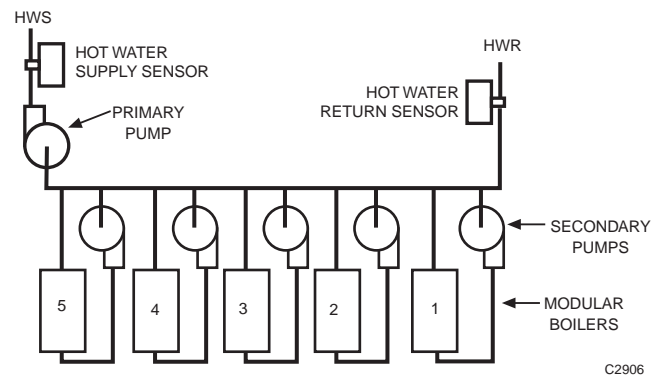

Fig. 50. Typical Primary-Secondary Piping for Modular Boilers.

HOT AND CHILLED WATER DISTRIBUTION SYSTEMS CONTROL

INTRODUCTION

Hot and chilled water pumping, distribution, and control systems have similar characteristics. A hot and/or chilled water system distributes heating or cooling energy through a building. The water is pumped from a boiler or chiller to coils or terminal units. Effective control of this energy requires understanding the control loops and related control valves and also an understanding of the pressure/flow relationships between the piping and pumping components of the system.

CLASSIFICATION OF WATER DISTRIBUTION SYSTEMS

Water distribution systems used in buildings include:

- **LTW.** Low temperature water systems supply water at temperatures up to 120°C and working pressures up to 1200 kPa. Although, most LTW boilers have a maximum working pressure of 300 kPa.

- **MTW.** Medium temperature water systems supply water at temperatures between 120°C to 180°C with pressures up to 1200 kPa. Maximum medium temperature boiler temperature is 180°C.
- **HTW.** High temperature hot water systems supply water at temperatures over 180°C, usually in the 200°C to 230°C range, with working pressures up to 2100 kPa.
- **CHW.** Chilled water systems supply water at temperatures from 4.5°C to 13°C with pressures up to 860 kPa.
- **DTW.** Dual temperature water systems supply LTW during the heating season and CHW during the cooling season to the same terminal units.

TYPICAL WATER DISTRIBUTION SYSTEM

A typical system (Fig. 51) illustrates the principles of water distribution in a system. The system consists of a heating or cooling source, a pump, distribution piping, and valve controlled coils. The pump provides force to push the water through the system and valves control the flow through the individual coils. The air separator removes entrapped air from the system.

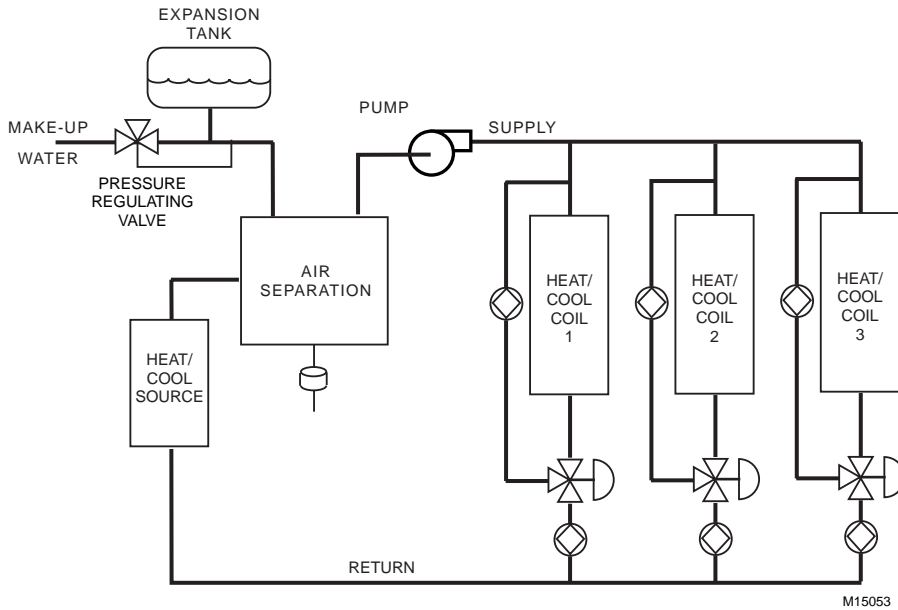

Fig. 51. Typical Water Distribution System.

The expansion tank is charged with compressed air to place the system under the minimum pressure required at the inlet to the pump to prevent pump cavitation and the resultant impeller erosion. The minimum inlet pressure required by a pump is referred to as the net positive suction pressure. Figure 54 indicates the pressure for a particular pump. The air volume in the tank is sized, based upon the volume of water in the system and the expected water temperature variations, to allow the water to expand and contract as water temperatures vary throughout the year. The expansion tank static pressure does not effect the closed system control valve differential close-off pressure, but must be considered, in addition to the pump pressure, for valve body and other piping system component pressure rating selection.

The air separator and expansion tank are omitted from the examples in this section for simplicity.

CONTROL REQUIREMENTS FOR WATER DISTRIBUTION SYSTEMS

The requirements of a properly applied distribution system are:

1. Maintain controllable pressure drop across the control valves.
2. Maintain required flow through the heating (or cooling) source.
3. Maintain desired water temperature to the terminal units.
4. Maintain minimum flow through the pump(s) that are running.
5. Maintain pump pressure.
6. Stage the pumps of a multipump system to satisfy conditions 1 through 5.

CENTRIFUGAL PUMPS USED IN HOT AND CHILLED WATER SYSTEMS

The pump is a key component of a water distribution system. It is essential to understand pump characteristics in order to understand and design distribution systems and to understand pumping system control solutions. Centrifugal pumps are commonly used to distribute hot and chilled water through commercial buildings. Many varieties of centrifugal pumps are available, as shown in Table 2. Figure 52 shows a typical base-mounted pump.

Table 2. Characteristics of Centrifugal Pump Types.

Type	Impeller Type	No. of Impellers	Casing	Motor Connection	Motor Mounting Position
Circulator	Single suction	One	Volute	Flexible-coupled	Horizontal
Close-coupled, end suction	Single suction	One or two	Volute	Close-coupled	Horizontal
Frame-mounted, end suction	Single suction	One or two	Volute	Flexible-coupled	Horizontal
Double suction, horizontal split case	Double suction	One	Volute	Flexible-coupled	Horizontal
Horizontal split case, multistage	Single suction	Two to five	Volute	Flexible-coupled	Horizontal
Vertical inline	Single suction	One	Volute	Flexible- or close-coupled	Vertical
Vertical turbine	Single suction	One to twenty	Diffuser	Flexible-coupled	Vertical

Source: ASHRAE Handbook—1996 Systems and Equipment

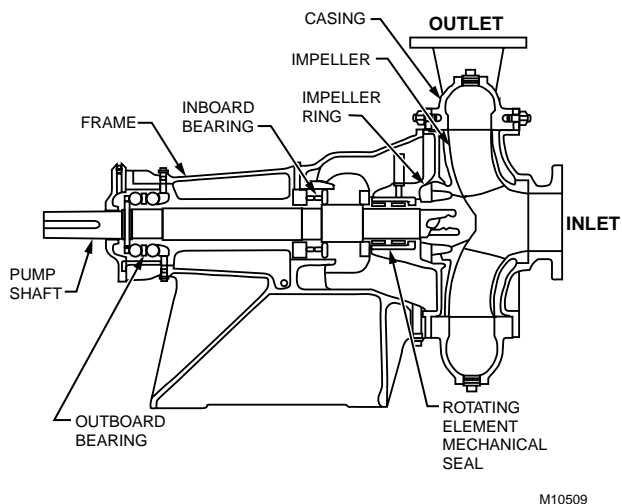

Fig. 52. Typical Cross-Section of an End Suction Pump.

PUMP PERFORMANCE

The performance of a given pump is expressed in a curve showing pump pressure versus flow. Figure 53 shows a typical curve. The pump pressure is expressed in kilopascals which describes pump operation independent of water temperature or density. Pressure losses in piping and components used in HVAC systems are always calculated in kilopascals.

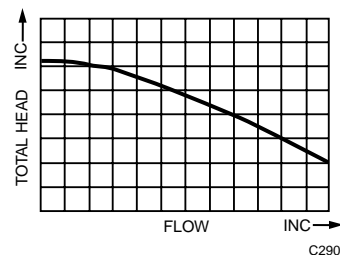

Fig. 53. Typical Pump Pressure Capacity Curve.

Pump Power Requirements

The pump curve in Figure 53 is part of a family of curves for a pump. Each curve of the family represents a different size impeller used with the pump at a specified rpm. It relates to the power input required just to move the water (water power) as follows:

$$\text{Water power, } W = \text{flow} \times \text{pressure}$$

Where:

$$\begin{aligned} \text{flow} &= \text{L/s} \\ \text{pressure} &= \text{kPa} \end{aligned}$$

The motor driving the pump must have a power rating in excess of water power to take care of bearing and seal friction, recirculation within the housing, and impeller efficiency.

NOTE: Water power increases with pressure and flow. If flow is allowed to increase, the motor may overload.

Pump Performance Curves

Commercial pumps have performance curves showing the following data for a given pump speed:

- Total pressure in kPa versus flow in L/s
- Total pressure versus flow for various impeller diameters
- Pump efficiency at various operating points
- Net positive suction pressure. Net positive suction pressure is the absolute pressure in kPa required at the suction inlet to prevent cavitation due to “boiling” and formation of bubbles in the water.

Figure 54 is a typical performance curve showing some of the preceding data. Impeller diameters are shown on the left.

Pump Efficiency

Pump efficiency is a comparison of water power developed in the pump and motor power applied by the motor to the shaft and impeller.

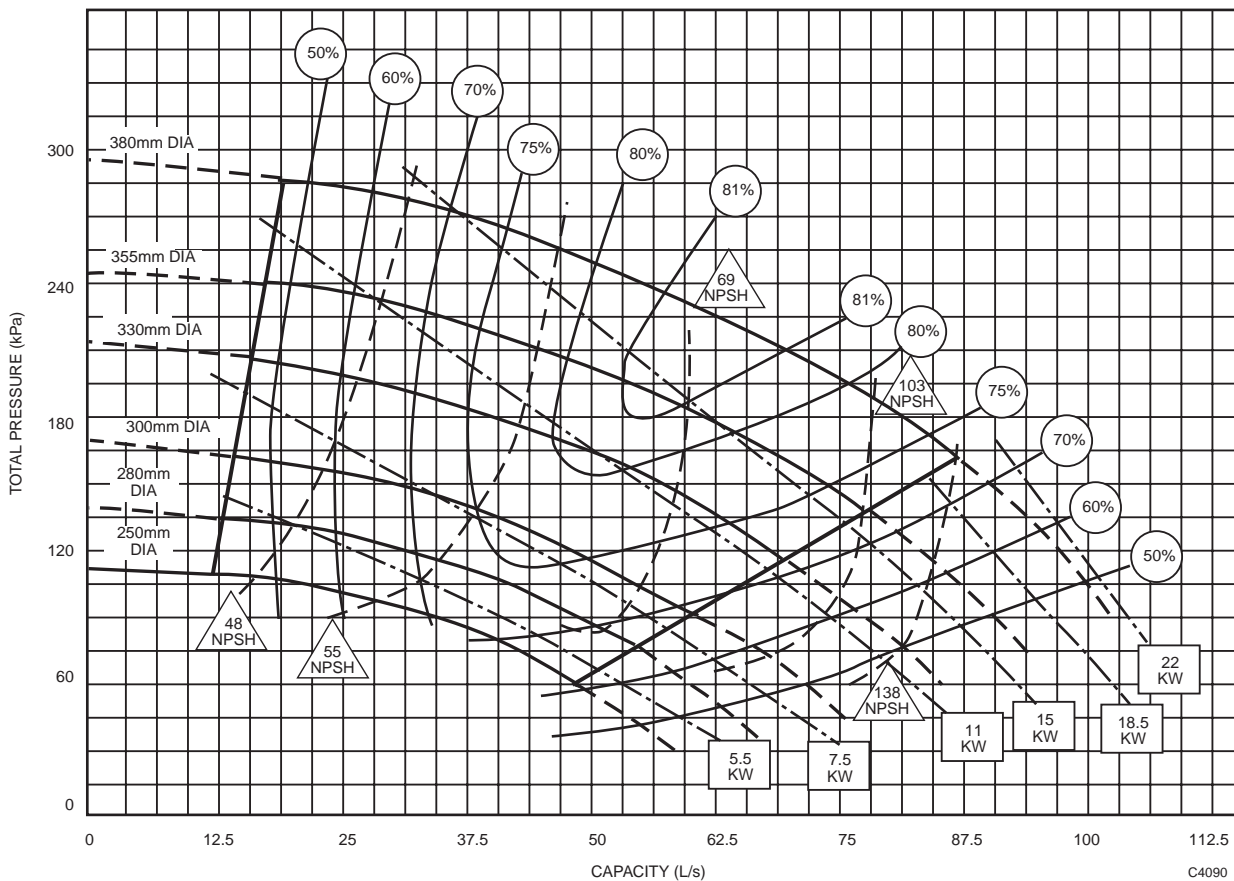

Courtesy of Aurora Pump
Fig. 54. 1150 RPM Typical Pump Curve.

Figure 55 illustrates a pump fitted with a 165 mm impeller, operating at 130 kPa, and delivering 4.2 L/s of water.

$$\begin{aligned} \text{Water power} &= 4.2 \text{ L/s} \times 130 \text{ kPa} \\ &= 546 \text{ W} \end{aligned}$$

The curves show that the motor output is 850 watts. Efficiency = (water power)/(motor power) x 100 = (546/850) x 100 = 64 percent. This agrees with the efficiency curves shown in Figure 55.

Pump Affinity Laws

Pump affinity laws (Table 3) show how pump flow, pressure, and motor power vary as impeller diameter or speed change. These laws help when adjusting an installed pump to changes in the system served. For example, if a pump with a 210 mm impeller delivers 240 kPa, with a 190 mm impeller it would deliver 196 kPa. It is calculated as follows:

$$\begin{aligned} \text{New pressure} &= \text{Old pressure} \times \left(\frac{\text{New Diameter}}{\text{Old Diameter}} \right)^2 = 240 \left(\frac{190}{210} \right)^2 \\ &= 196 \text{ kPa} \end{aligned}$$

Table 3. Pump Affinity Laws.

Impeller Diameter	Speed	Specific Gravity (SG)	To Correct for	Multiply by
Constant	Variable	Constant	Flow	$\left(\frac{\text{New Speed}}{\text{Old Speed}} \right)$
			Pressure	$\left(\frac{\text{New Speed}}{\text{Old Speed}} \right)^2$
			Power or kW	$\left(\frac{\text{New Speed}}{\text{Old Speed}} \right)^3$
Variable	Constant	Constant	Flow	$\left(\frac{\text{New Diameter}}{\text{Old Diameter}} \right)$
			Pressure	$\left(\frac{\text{New Diameter}}{\text{Old Diameter}} \right)^2$
			Power or kW	$\left(\frac{\text{New Diameter}}{\text{Old Diameter}} \right)^3$
Constant	Constant	Variable	Power or kW	$\frac{\text{New SG}}{\text{Old SG}}$

Source: ASHRAE Handbook--1996 System and Equipment

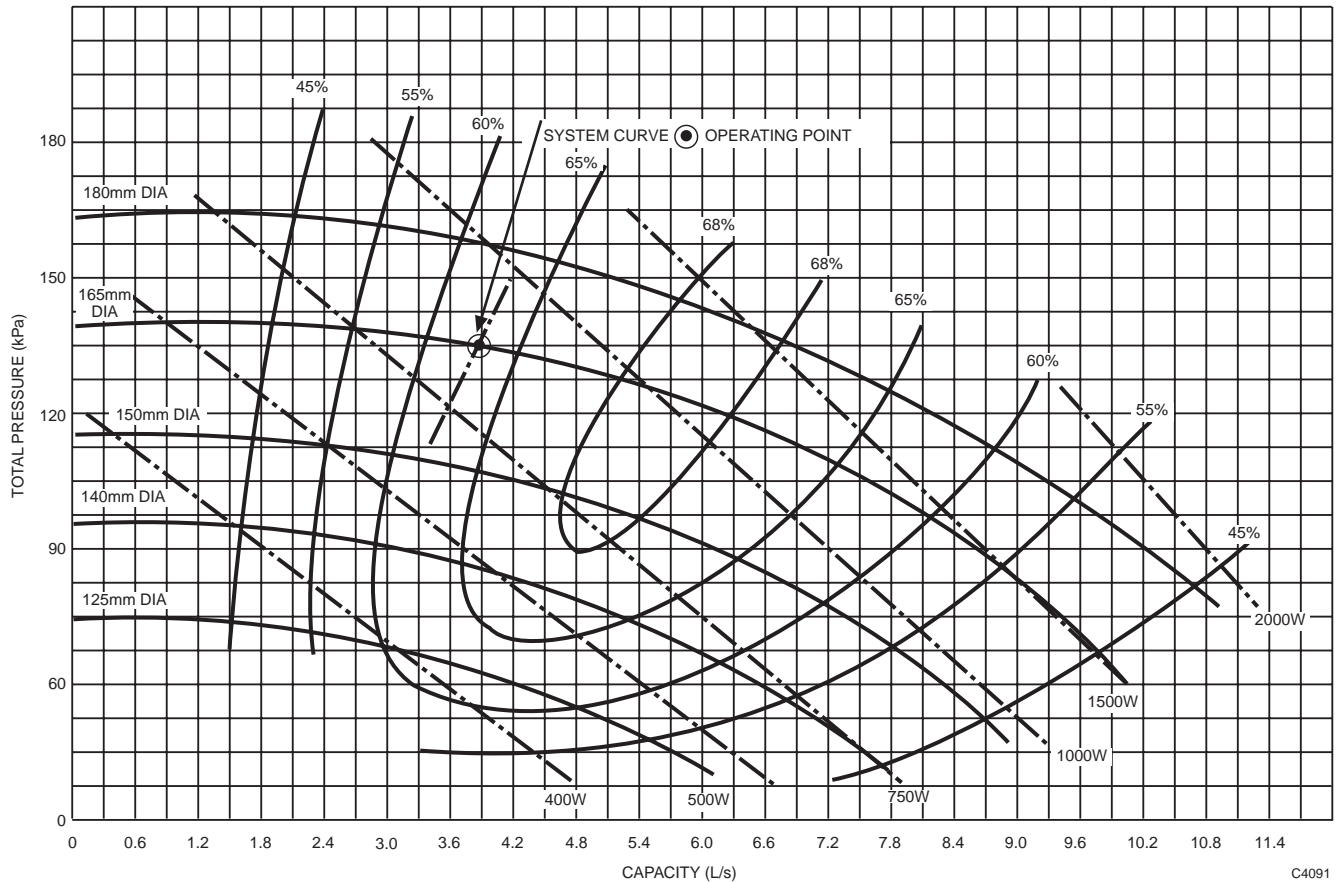

Fig. 55. Pump Curve for 1750 RPM Operation.

MATCHING PUMPS TO WATER DISTRIBUTION SYSTEMS

System Curves

The pump curves and affinity laws are used to select a pump or pumps for a particular application. The first step is to establish a system pressure curve. This is calculated from design flow and pressure loss tables for all the piping, coils, control valves, and other components of the system.

Plotting A System Curve

An example is shown in Figure 56. The design point is 195 kPa at a 32.2 L/s flow. A system curve (a simple square root curve) can be plotted once the flow and pressure loss are known at any particular point, since:

$$\left(\frac{\text{flow}_2}{\text{flow}_1}\right)^2 = \frac{p_2}{p_1}$$

Where:

- flow₁ = flow at p₁ in kPa
- flow₂ = flow at p₂ in kPa

Plot the points (Fig. 56) for flows of 12.5, 25, and 37.5 L/s:

Point A: $\left(\frac{12.5}{32.2}\right)^2 \times 195 \text{ kPa} = 0.1507 \times 195 \text{ kPa} = 29.4 \text{ kPa}$

Point B: $\left(\frac{25}{32.2}\right)^2 \times 195 \text{ kPa} = 0.6028 \times 195 \text{ kPa} = 117.5 \text{ kPa}$

Point C: $\left(\frac{37.5}{32.2}\right)^2 \times 195 \text{ kPa} = 1.356 \times 195 \text{ kPa} = 264.5 \text{ kPa}$

The system curve assumes all balancing valves are set for design conditions, that all controls valves are fully open, and that flow through all loads is proportional. The system curve is always the same, even if loading is not proportional, at no load and full (100 percent) load. If the loads are not proportional (such as, some loads off or some valves throttling), the curve rises above that shown for values between full and no load. The system curve in Figure 56 is used in Figure 57 to select the single speed pump. Using this system curve to determine the switching setpoint for dual parallel pumps when the load flow is not proportional can result in damaging pump cycling.

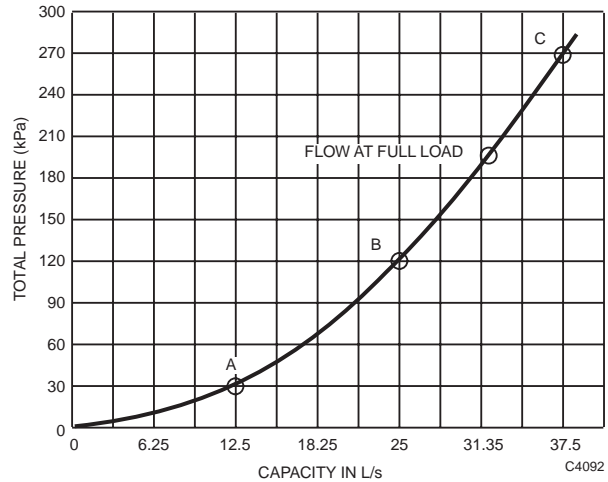

Fig. 56. System Curve for Pump Application.

Combining System And Pump Curves

The design system flow is 32.2 L/s. Piping, control valve, and equipment losses are calculated at 195 kPa. An impeller size and a motor power are selected by imposing the system curve on the pump curve (Fig. 57). The designer has the option of selecting a pump with a 240 mm impeller (32.2 L/s at 233 kPa) or a 220 mm impeller (30.5 at 180 kPa). The smaller impeller requires a 7500 watt motor and the larger impeller requires a 9000 watt motor. Selection of the 240 mm impeller requires system balancing valves to reduce the system pressure differentials to those matching the design flow of 32.2 L/s.

When selecting a pump, it is important to remember that:

- With constant speed pumps (and two-way AHU control valves), flow rides the pump curve. The system curve is plotted assuming that the control valves are full open, which in any system, only occurs at the full load. As control valves throttle and loads are turned off the system becomes non-proportional and the system curve rises between no load and design.
- With variable speed pumps, the system control objective is to have the pump curve ride the system curve by keeping at least one control valve open and reducing the pump speed to reduce flow with the diminishing system drop.

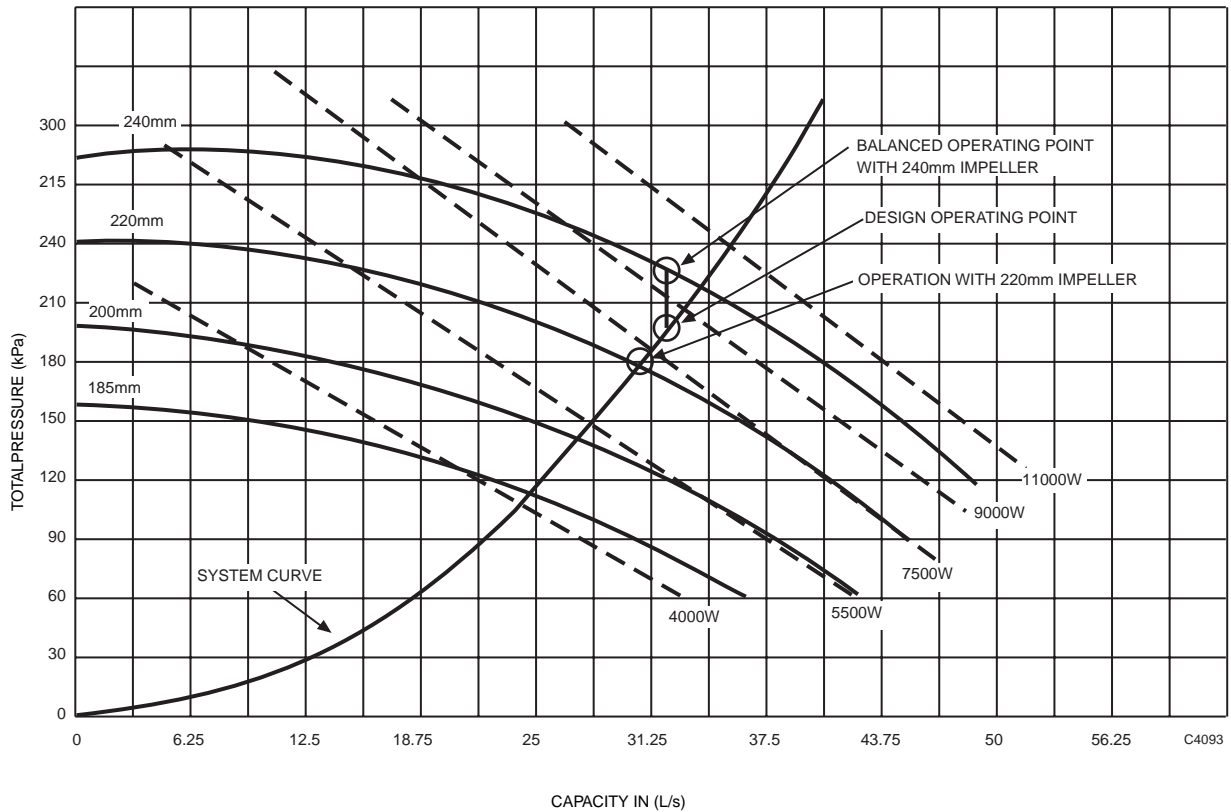

Fig. 57. Matching Pump to System.

To better understand system curves, pump curves, and flow control, Figure 58 shows the control valve(s) (the only variable element of a typical system curve) separately from the rest of the system elements. Lines are shown for each of three valve positions; full, 80 percent, and 50 percent flow. These lines, when added to the curve for all other elements of the system intersect the pump curve at the corresponding operating point(s).

Figure 58 shows a system with 31.25 L/s and 210 kPa loss at design, 30 kPa of which is a full open control valve at the end of the piping run. Line "A" represents the control valve and connects the pump curve to the static-element system curve. If all control valves positioned to 80 percent flow, the static-element system resistance drops, and the control valve, represented by line "B", makes the difference; about 105 kPa. Similarly, at 50 percent flow, the valve drop, represented by line "C", accounts for about 220 kPa.

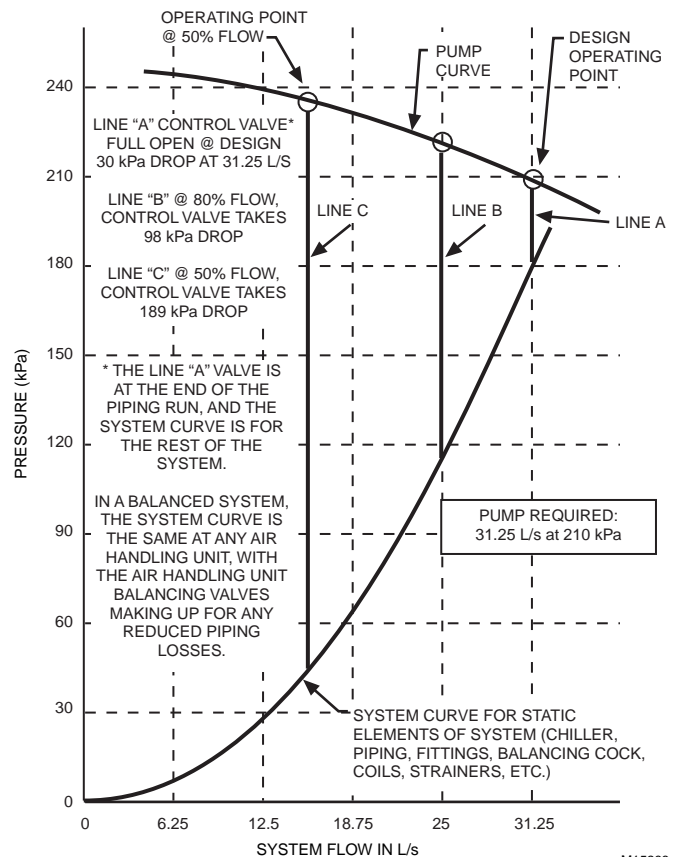

Fig. 58. Pump and System Curves and Control Valves

VARIABLE SPEED PUMPS

From the pump affinity laws (Table 3), pump power decreases by the cube of the decreased speed, and flow decreases linearly with speed; so at 80 percent flow, the power (kW) is down to nearly 50 percent (80 percent cubed). Since many systems have sharply reduced flow requirements at medium or low loads, pump speed control can provide economical operation for most of the heating (or cooling) season. Figure 59 shows typical performance at reduced speeds. The shaded area of Figure 60 shows the wide range of pressures and flows available from a variable speed pump. Variable speed pumps are usually controlled from a differential pressure sensor with either fixed or load reset setpoints.

Control objectives of variable speed pumping systems in networked digital control systems, is to keep the most demanding load control valve full open by varying the pump speed.

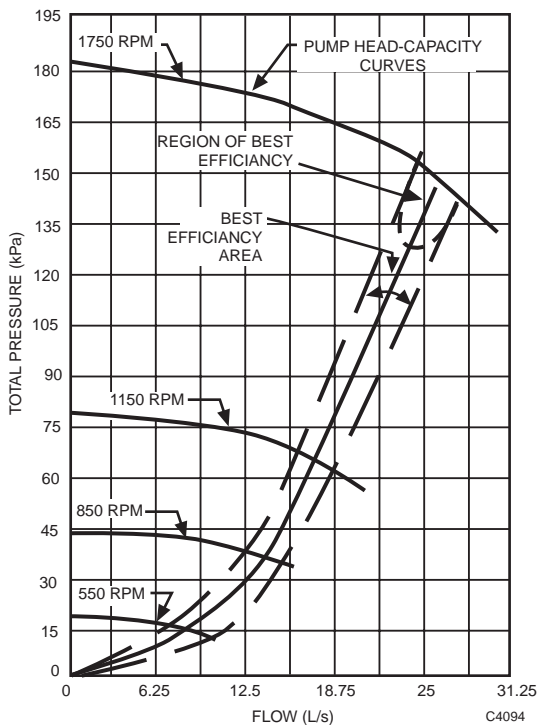

Fig. 59. Pump Performance and Efficiency at Various Speeds.

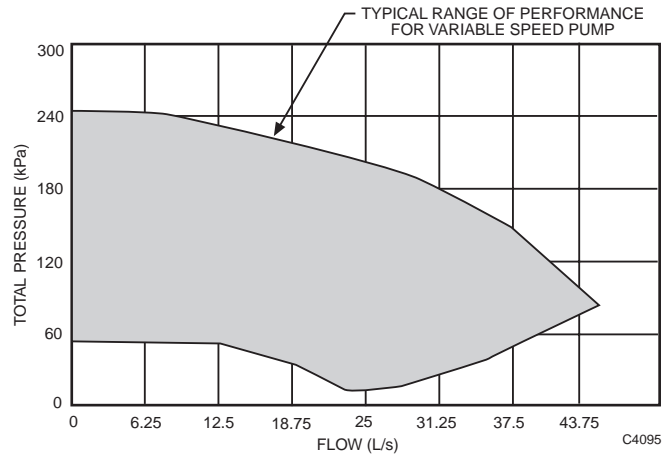

Fig. 60. Typical Variable Speed Pump Performance Range.

Table 4 and Figure 61 show the Figure 58 system with all the control valves remaining full open and the load controlled by varying the pump speed. This is the ideal system wherein the loads of all AHUs vary in unison and the pump speed is controlled to satisfy the valve with the greatest demand. This is usually accomplished via differential pressure control, automatically reset.

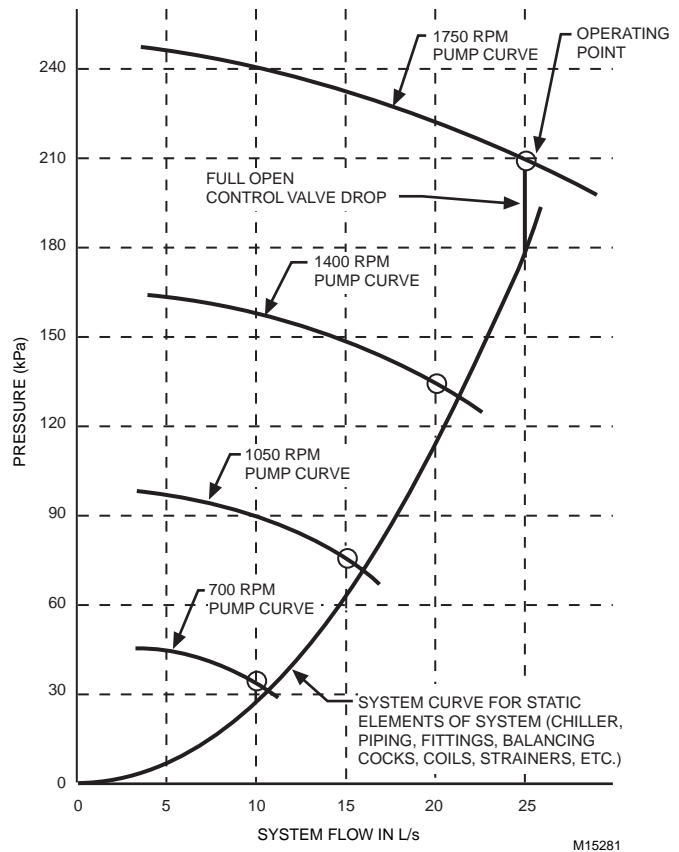

Fig. 61. Ideal Variable Speed Pump Control.

Table 4. Variable Speed Pump relationships

Condition	Load (percent)			
	100	80	60	40
Flow (L/s)	31.5	$0.80 \times 31.5 = 25.2$	$0.60 \times 31.5 = 18.9$	$0.40 \times 31.5 = 12.6$
Speed (rpm)	1750	$0.80 \times 1750 = 1400$	$0.60 \times 1750 = 1050$	$0.40 \times 1750 = 700$
Total Pressure (kPa)	210	$210 \times \left(\frac{1400}{1750}\right)^2 = 134.4$	$210 \times \left(\frac{1050}{1750}\right)^2 = 75.6$	$210 \times \left(\frac{700}{1750}\right)^2 = 33.6$
Fully Open Valve Drop (kPa)	30	$30 \times 0.80^2 = 19.4$	$30 \times 0.60^2 = 10.8$	$30 \times 0.40^2 = 4.8$
Motor Power (kW)	10.1	$10.1 \times \left(\frac{1400}{1750}\right)^3 = 5.17$	$10.1 \times \left(\frac{1050}{1750}\right)^3 = 2.18$	$10.1 \times \left(\frac{700}{1750}\right)^3 = 0.65$

PUMPS APPLIED TO OPEN SYSTEMS

In cooling towers (Fig. 62) and other open systems, static pressure must be considered when establishing system curves and selecting a pump. Notice that the 27m of vertical pipe (270 kPa static discharge pressure) is partially offset by the 24m of vertical pipe (240 kPa static suction pressure) in the suction line. When a system curve is drawn for such a system, static pressure of the tower must be added to the system curve. The system in Figure 63 is drawn through zero pressure (ignoring the 3m or 30 kPa static pressure) which leads to choosing Pump A.

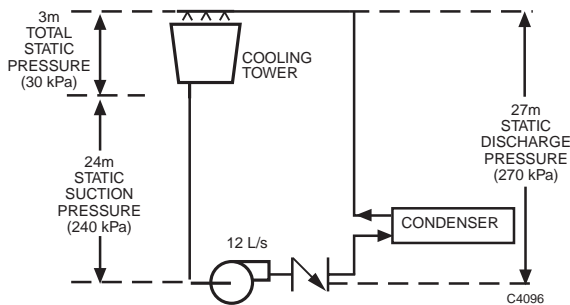

Fig. 62. Typical Cooling Tower Application.

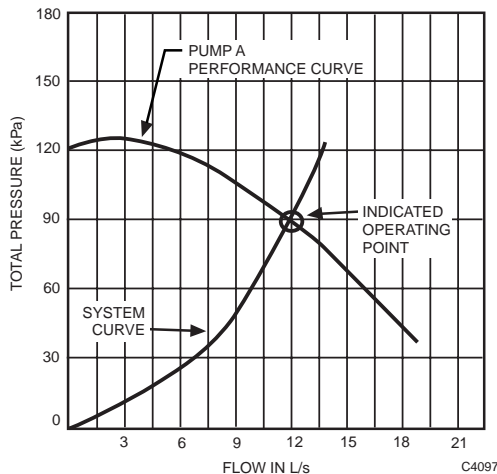

Fig. 63. System Curve for Open Circuit without Static Pressure.

Figure 64 shows the system curve adjusted for the 30 kPa of static pressure and the actual operating points of Pump A (selected in Figure 63) and Pump B. Notice Pump A supplies only 10.5 L/s at 125 kPa.

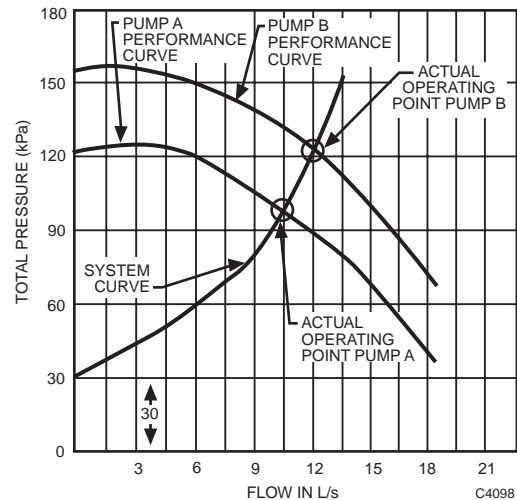

Fig. 64. System Curve for Open Circuit with Static Pressure.

MULTIPLE PUMPS

Multiple pumps are used when light load conditions could overload a single pump. These conditions normally occur when two-way control valves are used in the control system. Two-way control valves sharply reduce flow when they begin to close. Figure 65 shows that in a single-pump system, over pressure can result at low flow. At one-third flow, the pump pressure has increased, the source and piping drop is reduced to one-ninth of the design drop, and the control valve drop has increased greatly. Bypass, variable speed, or throttling valve pressure relief should be used with a single pump. Where the heat exchanger (such as a chiller) requires a high minimum flow rate, a single pump is used, and diversity is not used, three-way load control valves should generally be used.

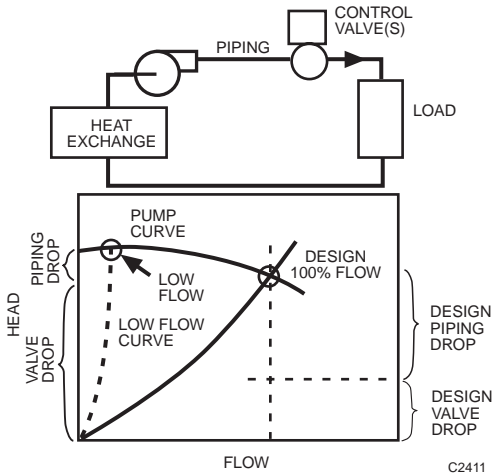

Fig. 65. System Operation with One Pump, Design and Low Flow Condition.

Operation

Multiple pumps may be connected either in parallel or in series into the system. In the dual parallel pump configuration of Figure 66 a single pump can usually handle 75 to 80 percent of the total flow. The system curves show that at design conditions the control valve drop is 30 kPa (from A to B). At 75 percent flow (21 L/s), the valve drop with both pumps operating increases to over 125 kPa (C to E). With one pump and 75 percent flow the valve drop is about 50 kPa (C to D). When flow is reduced to 50 Percent, the valve drop is about 165 kPa for one pump (F to G) or 190 kPa for two pumps (F to H). Dual parallel pumps save energy and provide redundancy for 75 to 80 percent of the flow. They do not provide much relief for high valve pressure drops at low flow.

The pump curves and the system curves indicate possible pump start/stop setpoints. One scenario on a pumping differential fall to 130 kPa, energizes the second pump and on a pumping differential rise to 235 kPa, switches back to one pump. The 130 kPa pumping differential corresponds to a point just before the 1-pump curve intersects the system curve (I), the point at which a single pump no longer can support the system. When the second pump is started, the operating point moves to the 2-pump curve and when the control valves have settled out will be at about Point J. It will vary along the 2-pump curve down to B or up to K. When the operating point reaches K (about 235 kPa) the system switches back to a single pump and the operating point is now on the 1-pump curve until the differential pump pressure drops to I, at which time the cycle repeats. See PLOTTING A SYSTEM CURVE for statement on use of ideal system curve for determining setpoints when coil loading may not be proportional.

Again a reminder to exercise caution when using the ideal system curves for switching pumps on and off. The ideal curves are valid only at full and no load conditions, the rest of the time the actual curve is somewhere above the ideal. Since setpoint determination is not possible without the actual system curve,

the lag pump stop setpoint should have a significant margin of safety incorporated. The lag pump start setpoint should be controlled by a differential pressure controller and have the software requirement that one control valve be full open for four minutes before starting.

Time delays must be built in to the control sequence to prevent rapid switching between one pump and two pump operation. With each change in pump operation, all control valves must adjust to new steady-state conditions. The adjustment process often causes overshoot or undershoot until temperature stability returns and no switching should take place during this time. Depending upon the type of temperature control loops, switch-lockout period can vary from 5 minutes for relatively fast discharge air control to over 30 minutes for relatively slow space control.

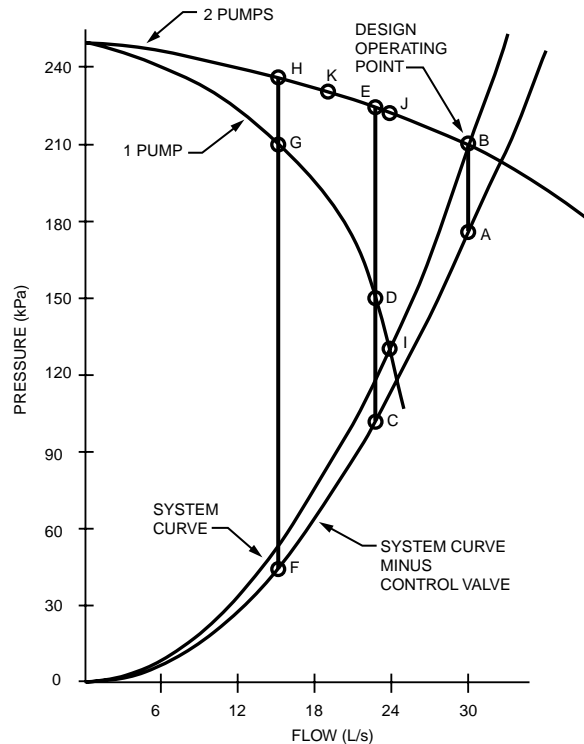
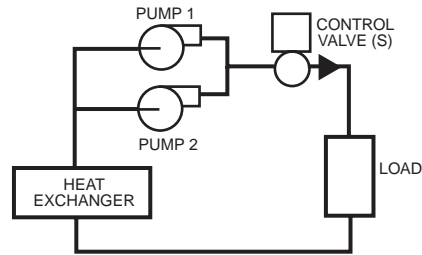

Fig. 66. System Operation with Two Pumps in Parallel.

Series pumps (Fig. 67), though rarely used in HVAC systems, are useful where both flow and pressure are sharply reduced at light loads.

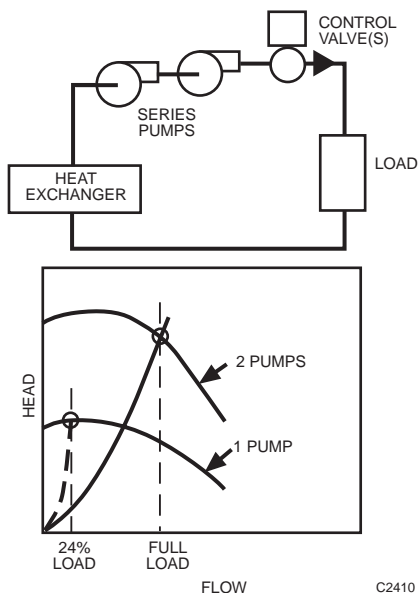
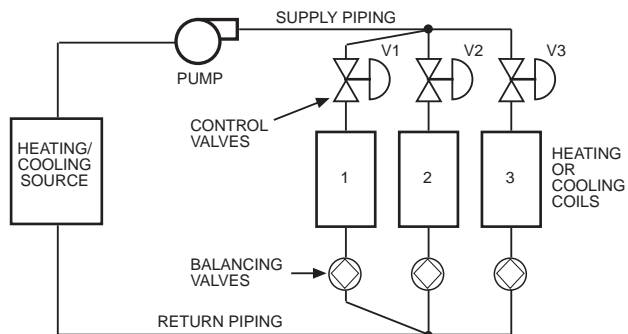

Fig. 67. System Operation for Series Pumps.



ITEM	FLOW IN L/s	DESIGN PRESSURE DROP IN kPa		
		COIL & PIPING	CONTROL VALVE	BALANCING VALVE
HEATING OR COOLING SOURCE AND DISTRIBUTION PIPING	2.5	69*	—	—
COIL 1 LOOP	0.6	24	33	6
COIL 2 LOOP	0.8	30*	33*	0*
COIL 3 LOOP	1.1	21	33	9
TOTAL FLOW AND DROP	2.5	132*		

* SUM OF SOURCE AND PIPING (69 kPa) AND COIL LOOP 2 (63 kPa) = 132 kPa
C4603

Fig. 68. Simplified Water Distribution System.

Dual Pump Curves

For pumps in parallel (Fig. 66), assuming two identical pumps, the curve is developed using the following formula:

$$\text{flow}_3 = (\text{flow}_1) \times 2 \text{ for any } p_1$$

Where:

- flow₃ = Total flow for both pumps
- flow₁ = flow of one pump
- p₁ = Pressure in kPa for Pump 1 at flow₁ for any point on pump curve

For pumps in series (Fig. 67), assuming two identical pumps, the curve is developed using the following formula:

$$p_3 = (p_1) \times 2 \text{ for any flow}_1$$

Where:

- p₁ = Total pressure in kPa for both pumps
- p₁ = Pressure in kPa for one pump at flow₁ (for any point on Pump 1 curve)

DISTRIBUTION SYSTEM FUNDAMENTALS

Figure 68 illustrates a closed system where static pressure (pressure within the system with pump off) does not need to be considered as long as all components are rated for the static pressure encountered. The pump provides force to overcome the pressure drop through the system and valves control the flow and pressure through the system. Figure 69 shows a graph of the system and pump curves for design load and reduced load conditions. The system curve indicates the pressure drop through the system (with the control valves full open) at various flow rates. The pump curve shows the pump output pressure at various flow rates. Flow always follows the pump curve.

- In Figure 68 the flow and pressure considerations are:
1. The flow through the heating or cooling source, the supply piping, and the return piping (2.5 L/s) is the same as the sum of the flows through the three coil circuits:

$$0.6 + 0.8 + 1.1 = 2.5 \text{ L/s.}$$

2. Design pressure drop includes the drop through the heating or cooling source, supply piping, return piping, and the highest of the three coil circuits:

$$69 + (30 + 33) = 132 \text{ kPa.}$$

NOTE: In this example, Coil 1 and 3 balancing valves balance each load loop at the 63 kPa design for Loop 2. If the actual coil and control valve drops were less than the design maximum values, the actual balancing valve effects would be greater.

In this example the pump must handle 2.5 L/s against a total pressure of 132 kPa as shown in Figure 69. (This curve is taken from actual pump tests). The design drop across the valve is 33 kPa with the valve fully open.

If Figure 68 is a heating system, as the loads reduce valves V1, V2, and V3 start to close. Hot water flow must be reduced to about 15 percent of full flow (0.375 L/s) to reduce heat output to 50 percent. As flow through the coil is reduced the water takes longer to pass through the coil and, therefore, gives up more heat to the air.

As flow through the system is reduced, a new system curve is established. See the 0.375 L/s curve in Figure 69. When the flow is reduced, the new pressure loss in source and supply and return piping can be calculated using the formula:

$$\left(\frac{\text{flow}_2}{\text{flow}_1}\right)^2 = \frac{p_2}{p_1}$$

Where:

- flow₁ = present flow
- flow₂ = next flow
- p₁ = present pressure drop
- p₂ = next pressure drop

For example: If flow₁ = 2.5 L/s, flow₂ = 0.375 L/s, and p₁ = 99 kPa, then p₂ = 2.2 kPa.

$$\left(\frac{0.375}{2.5}\right)^2 = \frac{p_2}{99}$$

$$p_2 = 99 \times 0.0225 = 2.2 \text{ kPa}$$

At low flow, the pressure drops through the coils, coil piping, and heat source tend to disappear and nearly all of the now elevated pump pressure appears across the partially closed valves V1, V2, and V3. This can cause valve noise, poor control, or failure of valves to seat. Control solutions are discussed in following sections.

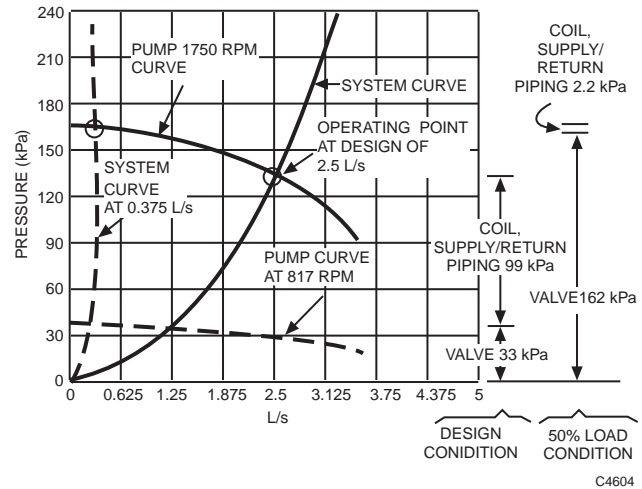

Fig. 69. System and Pump Curves for a Closed System at Various Loads.

DIRECT VS REVERSE RETURN PIPING SYSTEMS

Distribution system control solutions vary dependent upon whether the designer chose a direct or reverse return piping system. Systems are sometimes configured as a combination of both; a high-rise building could, for example be reverse return on the riser and direct return on the floor run-outs. Direct return systems are usually lower cost and used in smaller installations. Reverse return systems are used in both small and large installations.

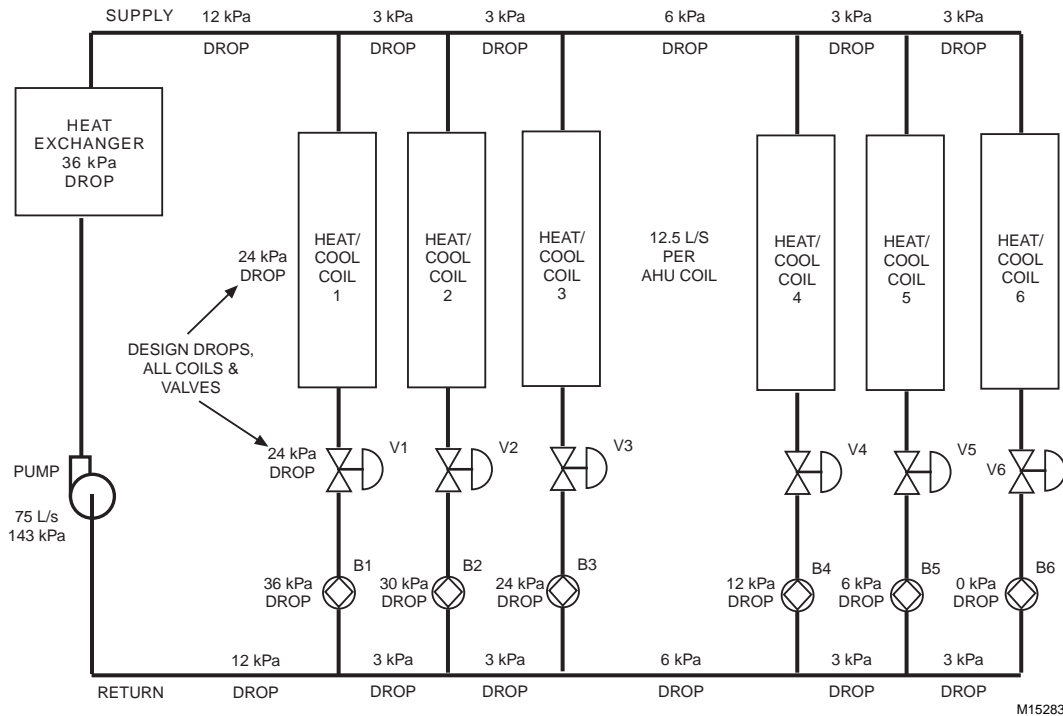

Fig. 70. Direct Return Piping System

The Figure 70 supply piping runs out to the coils decreasing in size between AHU 1, 2, 3, 4, 5, and 6. The return lines between each AHU are typically sized the same as the respective supply lines. The drop across AHU 6 must be 48 kPa in order to get the 12.5 L/s through the valve (24 kPa) and the coil (24 kPa). To get the 12.5 L/s from AHU 5 to AHU 6, the drop across the piping at AHU 5 is 54 kPa (48 kPa required to get the flow through AHU 6 plus 6 kPa to overcome the supply and return piping drops between AHU 5 and AHU 6). The AHU 5 balancing valve is set to prevent the 54 kPa drop across AHU 5 from forcing more than 12.5 L/s to pass through the AHU 5 coil and control valve. The balancing valve B5 then is set to take a 6 kPa drop at 12.5 L/s. Similarly, set a 12 kPa, 24 kPa, 30 kPa, and 36 kPa drop respectively across balancing valves B4, B3, B2, and B1.

If this is a variable flow loop with a variable speed pump and the pump is controlled to produce 48 kPa across AHU 6, the control issue here is: When AHUs 2, 3, 4, 5, and 6 are off (no flow beyond AHU 1), then, the drop across AHU 1 is only 48 kPa, 36 kPa of which the AHU 1 balancing valve needs for design flow. Proper solutions are presented later in this section.

Supply piping is the same for a reverse return system (Fig. 71) as for the direct return system (Fig. 70). The return flow is reversed such that the return piping increases in size between AHUs 1, 2, 3, 4, 5, and 6. A full size return line is run back to the source room from AHU 6. In this example, the pump is the same as the direct return, since the return line from AHU 6 also takes a 18 kPa drop. If the AHUs and source were positioned in a circular or hex pattern such that Coil 6 is closer to the pump, the run from AHU 6 back to the source would be shorter, and the reverse return piping pressure would be less than for the direct return, and the piping cost would be similar. In reverse return systems, balancing is usually only a trimming exercise.

COUPLED VS DECOUPLED PIPING SYSTEMS

Piping systems requiring constant flow through primary equipment (chillers, boilers) and variable flow to AHUs may be coupled or decoupled. See CHILLER SYSTEM CONTROL and BOILER SYSTEM CONTROL for examples. Primary flow control for coupled systems and secondary flow control for decoupled systems are discussed later.

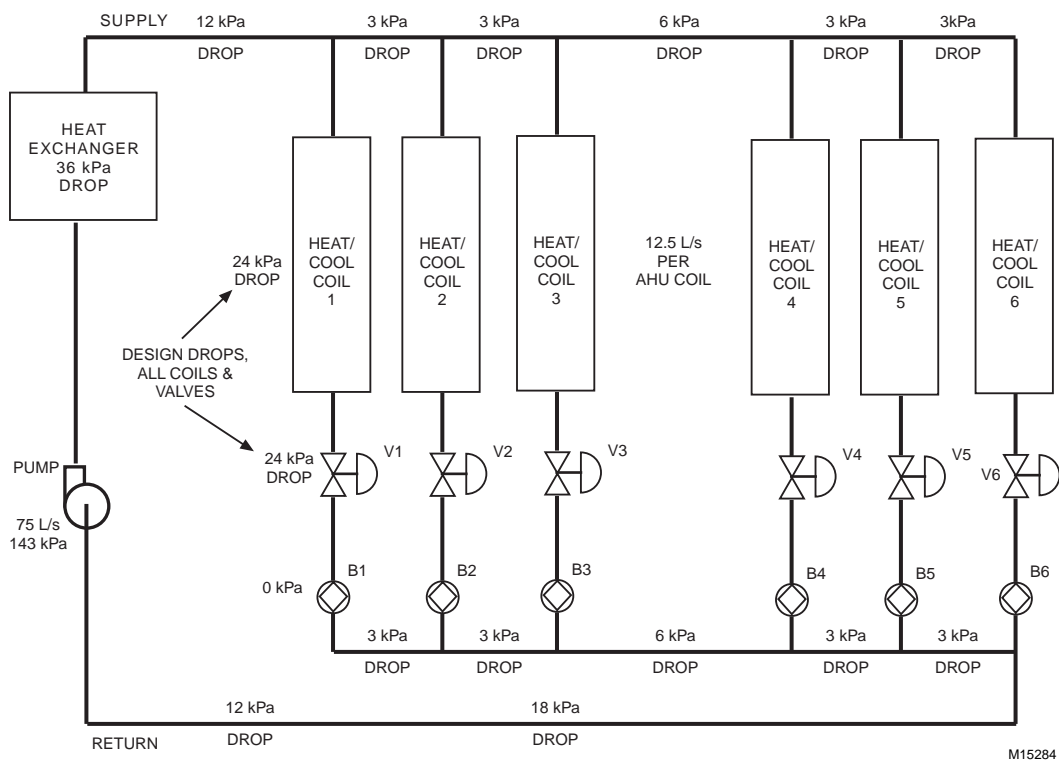

Fig. 71. Reverse Return Piping System

METHODS OF CONTROLLING DISTRIBUTION SYSTEMS

There are several methods for controlling pressure and flow in water distribution systems. The methods described in this section apply, in general, to both heating and cooling applications.

THREE-WAY COIL BYPASS AND TWO-WAY VALVE CONTROL

Coil bypass control uses three-way valves on terminal units and other coil loads in a water distribution system and satisfies the first four of the control system requirements (see CONTROL REQUIREMENTS FOR WATER DISTRIBUTION SYSTEMS). At reduced loads, the flow bypasses the coils and goes directly to the return main. Figure 72 illustrates the operation of this system as requirements change. Balancing valve (B) is adjusted for equal flow in the coil and the bypass

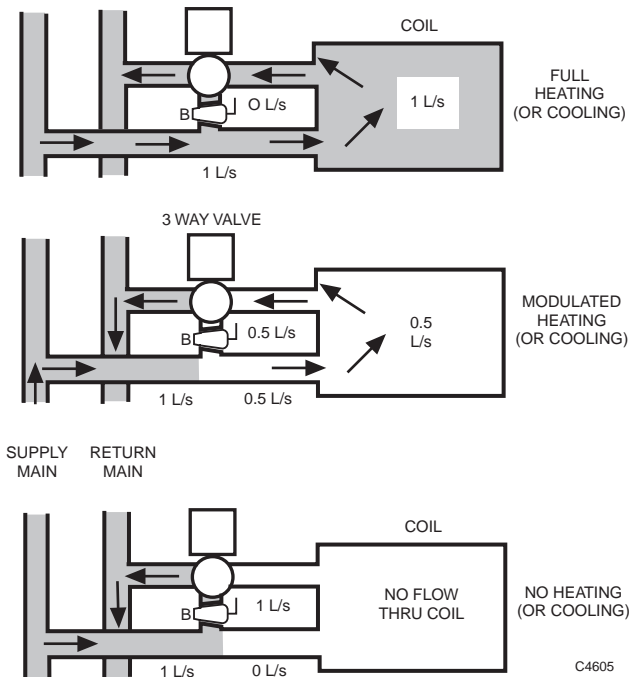

Fig. 72. Three-Way Valve Control—Coil Bypass.

Two way valves vary both the coil flow and the system flow, thus using less pumping energy at reduced flow.

VALVE SELECTION FACTORS

Consider the following factors when deciding on two-way or three-way control valves.

- **Piping Cost.** Costs are higher for three-way valves than two-way valves, especially where limited space is available for piping (such as in room air conditioning units and unit ventilators). In addition, balancing cocks must be installed and adjusted in the bypass line.
- **Three-Way Valve Cost.** A diverting valve is more expensive than a mixing valve and a mixing valve is more expensive than a two-way valve. A mixing valve installed in the leaving water from a coil provides the same control as a diverting valve installed on the inlet to the coil.
- **Diversity.** If chillers and pumps are selected based upon diversity, three-way valves are inappropriate.
- **Flow Characteristics.** Three-way valves have linear flow characteristics and two-way valves may be either linear or equal percentage. Obtaining close control with three-way valves requires use of scheduled (reset) hot water temperatures.
- **Capacity Index (K_V).** Three-way valves for K_V s below 1.0 are often not available, therefore, small three-way valves tend to be oversized. Consider using two-way control valves for all applications of $K_V = 4.0$ and less where the quantity of two-way valves will have little effect on the total system flow.
- **Constant Flow in Mains.** Constant flow provides nearly constant pressure differential (drop) across a coil and valve.
- **Pumping Cost.** A three-way valve system uses full pump capacity even when the system load is very small.
- **Part Load Control.** Two-way valves allow better control on multiple pump systems during pump failure or part load periods.
- **Automatic Control.** Distribution control is a manual balancing task for flow loops employing three-way control valves. Automatic distribution controls are usually required to maintain flows and pressures (bypass valve, variable speed pump, pump staging control) for flow loops employing two-way control valves.

For further discussion on control valves, refer to the Valve Selection and Sizing section.

FLOW AND PRESSURE CONTROL SOLUTIONS

Control solutions for water distribution systems may vary based on:

- Direct return vs reverse return piping
- Pressure bypass valve control vs variable speed pumping systems
- Coupled secondary systems vs decoupled systems
- Evenly varying heating/cooling loads vs unevenly varying loads
- Variable flow vs constant flow systems
- Single pump vs multiple parallel pump systems
- Pressure bypass valve objectives of maintaining high flow rates through chillers vs maintaining a low drop across control valves

The examples in this section on Flow And Pressure Control Solutions use a distribution system that has six equal loads (coils) as shown in Figure 73. These control solutions are:

1. Single constant speed pump, single chiller system, two-way AHU control valves, and pressure bypass valve to control chiller flow to a minimum of 90 percent full flow.
 - a. direct return.
 - b. reverse return.
2. Dual constant speed pumps, dual chiller systems, and pressure bypass valve to control chiller flow to a minimum of 90 percent full flow.
 - a. direct return.
 - b. reverse return.
3. High control valve differential pressure control.
4. Decoupled variable speed secondary pumping system with two-way AHU control valves.
 - a. direct return.
 - b. reverse return.

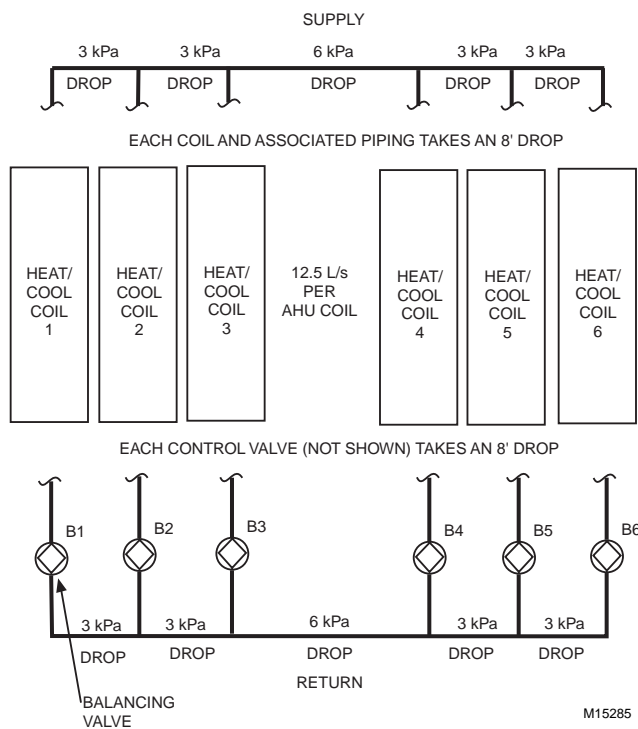

Fig. 73 Typical Example Loads.

Single Pump, Pressure Bypass, Direct Return

Figure 74 analyzes Figure 70 pumping system at full flow and at half flow. The flow reduction at half flow is taken evenly across each coil. At half flow with no pressure bypass the control valve pressure drops increase from 24 kPa to 132 kPa as system friction drops reduce to one-fourth of the design values and the pump pressure rises from 144 kPa to 162 kPa.

Figure 75 shows a pressure controlled bypass valve set to maintain 90 percent minimum flow through the chiller to satisfy the chillers minimum flow requirement. At 90 percent flow through the chiller (66 L/s), the chiller and equipment room

piping drops are 81 percent of design (90 percent squared). The pump curve (not shown) indicates a pump pressure of 150 kPa at 66 L/s.

VALVE LOCATION AND SIZING

Since the system piping between Loads 1 and 2 is designed for only 62.5 L/s and the low load bypass flow could exceed that, the bypass valve is located remotely before Load 1. If necessary to locate the bypass valve after Load 1, redesign the piping to carry the 90 percent flow.

If the differential pressure sensor is located across the main lines at Load 1 as shown in Figure 75 (see DIFFERENTIAL PRESSURE SENSOR LOCATION), the best place for the bypass valve is the same location. Because the differential pressure is lower than in the chiller room, valve wear is less.

The valve is sized for approximately 62.5 L/s with a 1036.5 kPa drop. A double seated valve is appropriate to reduce actuator close off requirements and the inherent leakage will not be a significant factor.

DIFFERENTIAL PRESSURE SENSOR LOCATION

As previously stated the chiller design flow is 75 L/s at 36 kPa and requires a minimum flow of 66 L/s. At 66 L/s the pump curve shows a pressure of 150 kPa.

From the formula:

$$\left(\frac{\text{flow}_2}{\text{flow}_1}\right)^2 = \frac{p_2}{p_1}$$

Calculate the drop across the chiller as 27.9 kPa.

$$\left(\frac{66}{75}\right)^2 = \frac{p_2}{36}$$

$$36 (0.88)^2 = p_2$$

$$p_2 = 36 \times 0.77 = 27.9 \text{ kPa.}$$

Similarly calculate the reduced drop in the supply and return to Load 1 as 9.3 kPa.

With the differential pressure controller located across Load 1, the setting is:

$$150 \text{ kPa} - 27.9 \text{ kPa} - 9.3 \text{ kPa} - 9.3 \text{ kPa} = 103.5 \text{ kPa}$$

This location provides a lower pressure across the load control valves at light loads than if located across the pump and chiller. To ensure the best sensing, be sure that the system strainer is located up stream from the differential pressure controller return pickup, so that a dirty strainer is not sensed as an increasing pressure drop (decreasing flow).

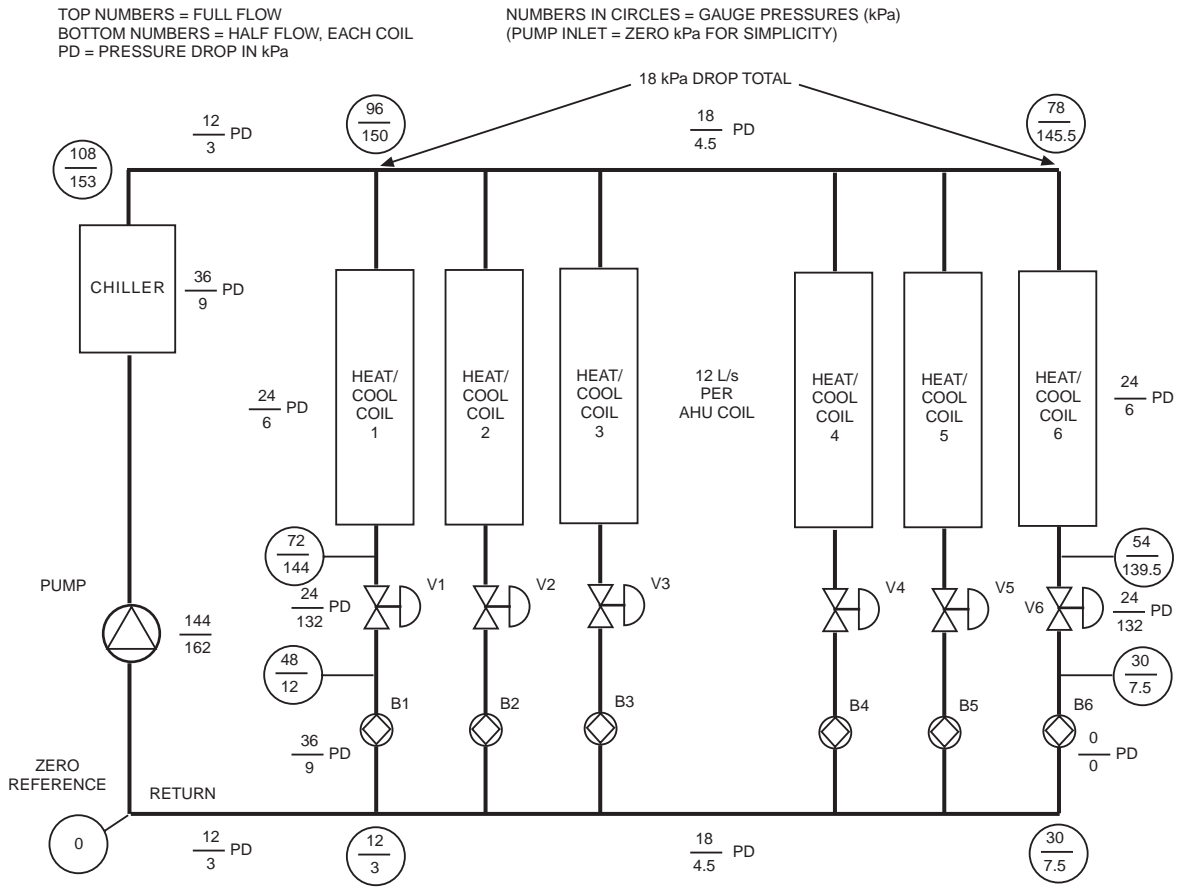

Fig. 74. Single Pump, Pressure Bypass, Direct Return at Full and Half Flow.

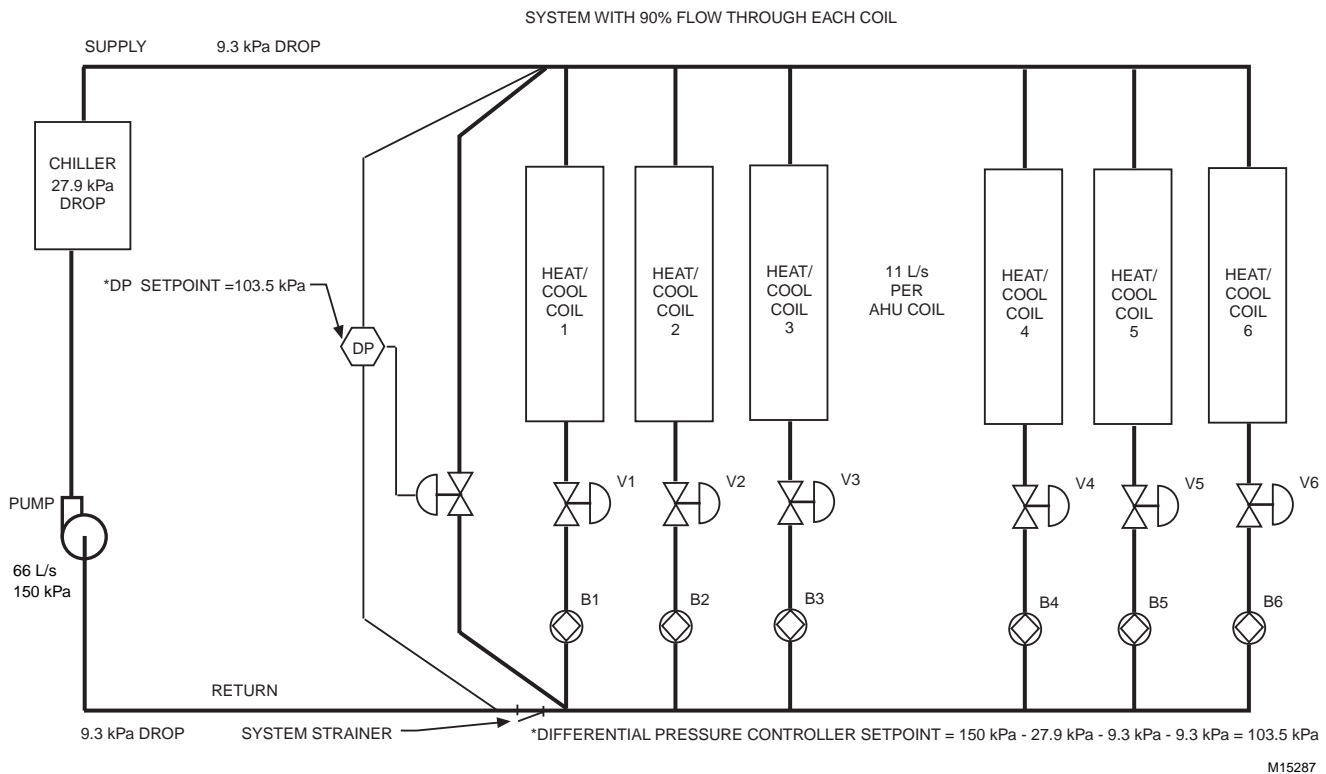

Fig. 75. Single Pump, Pressure Bypass System at 90 percent Flow.

The greatest change at the sensor provides the most tolerant and robust control. For this reason the sensor is located, not across the chiller with a setpoint of 27.9 kPa, but across Coil 1 where the greatest differential pressure change exists (84 kPa at design to 103.5 kPa at 90 percent of design).

NOTE: With the controller pickups in these locations, it does not matter where in the system the load is located, what value it has, or whether it is symmetrical or non-symmetrical.

Also note that the Load 1 balancing valve takes a full flow 36 kPa drop and even with the pressure bypass valve, the control valves will be subjected to drops of near 103.5 kPa for light loads. For larger and more extended systems, both of these values must be considered when evaluating reverse return and control valve high differential pressure solutions.

These values lead to the conclusion that a differential pressure bypass solution may satisfy the light-load flow through a chiller, but may not adequately relieve control valve light-load differential pressures on larger systems. Also be aware that pressure drop changes due to scaled chiller tubes effect the bypass valve operation.

Single Pump, Pressure Bypass, Reverse Return

A reverse return system analysis equivalent to the direct return analysis of Figure 74 would show that at half flow and no bypass, the pump pressure still rises to 162 kPa and the control valve drop still rises to 132 kPa.

For 90 percent flow control, the pump still operates at 150 kPa with the sensor located as far away from the pump as practical to take advantage of as many friction drop changes as possible.

The preferred sensor location (Fig. 76) is DP-1 if point A is near Load 1. Sensor location DP-2 is second best and again if point B is near Load 1. If location DP-3 is selected by default, with a setpoint of 122.1 kPa as compared with the DP-3 full flow differential pressure of 107 kPa. This small 15.1 kPa change requires a higher quality sensor and more frequent calibration checks than for locations DP-1 and DP-2. Locate the pressure bypass valve and sensor as far from the chiller/pump as possible, but no closer than DP-3.

In all cases it is still preferable to locate the system strainer outside the control loop as shown in Figure 75.

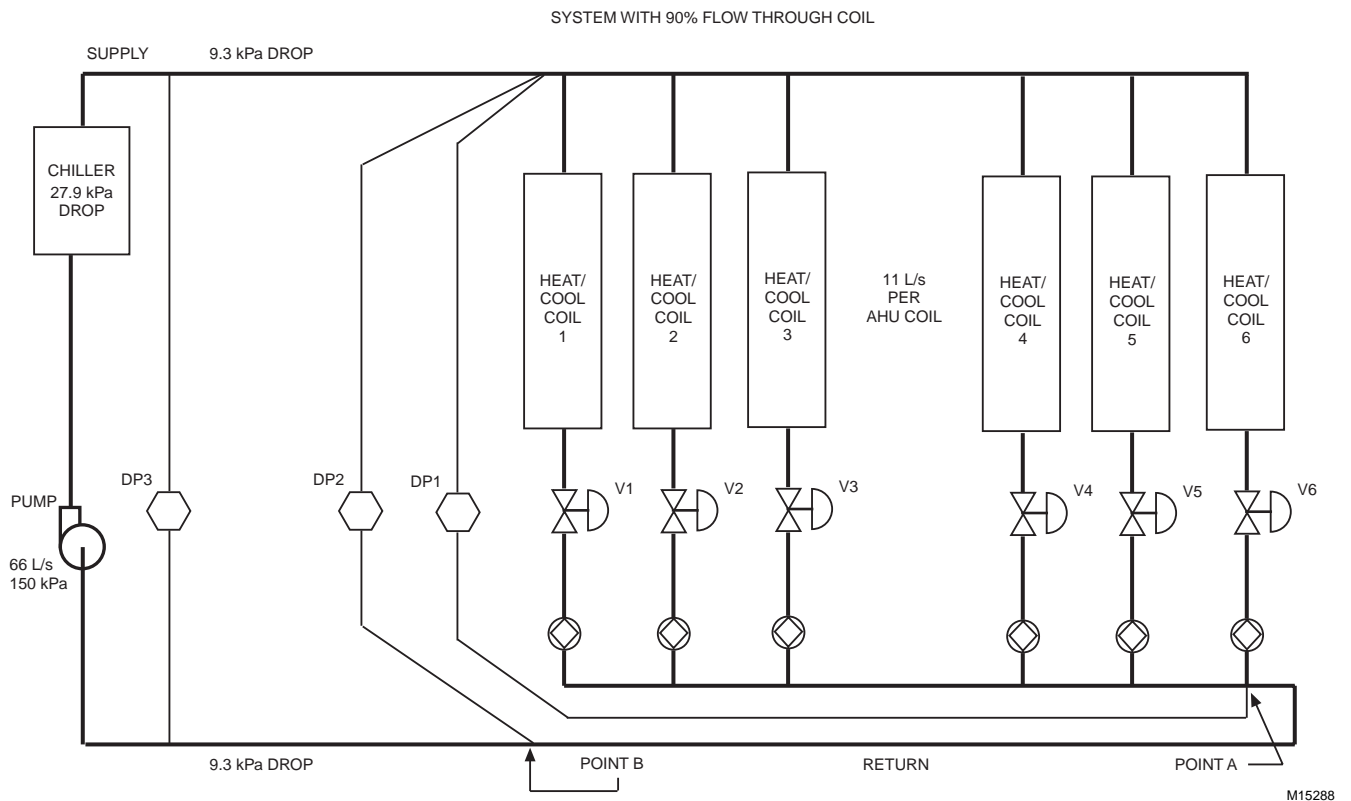

Fig. 76. Single Pump, Pressure Bypass, Reverse Return at 90 percent Flow.

Dual Pumps, Dual Chillers, Pressure Bypass, 90 percent Chiller Flow, Direct Return

Dual chiller pressure bypass systems are popular because if a chiller, tower, or pump fails, there is part load redundancy and better part load efficiency.

In Figure 77, the bypass sensor and valve is in the same location as the single chiller system (Fig. 75). The valve is sized for approximately 37.5 L/s.

The differential pressure setpoint is the same as for the single pump/chiller system (103.5 kPa) when both pumps are running. When only one pump/chiller is operating, the piping between the pump/chiller and differential pressure sensor carry a minimum of 33.75 L/s (90 percent flow for one chiller) and the piping friction drop falls from 12 kPa to 2.43, thus:

$$12 \left(\frac{33.75}{75} \right)^2 = p_2 = 0.243 \text{ kPa}$$

With a single pump/chiller operating, the differential pressure setpoint for 90 percent flow is 117.24 kPa.

Setpoint = 150 kPa (pump drop) – 27.9 kPa (chiller drop) – 2.43 kPa (piping pressure) – 2.43 kPa (piping drop) = 117.24 kPa.

This is up from the 103.5 kPa with both chillers operating.

With digital controls, the differential pressure setpoint offset adjustment when only one chiller/pump is operating is handled by a software routine (dual chiller/pump setpoint plus 14.4 kPa) invoked anytime only one pump and one chiller are operating.

One method using pneumatic controls uses two pressure controllers with separate setpoints. The primary controller is set at 117.24 kPa with the secondary controller set at 103.5 kPa setpoint and configured as a low limit device during periods of single pump/chiller operation. During periods of dual pump/chiller operation, the 103.5 kPa setpoint controller is used alone.

AHU Valve High Differential Pressure Control

As noted in the discussion of Figure 75, the differential pressure controlled bypass valve in constant speed pumping systems is adequate to maintain a high flow through chillers, but does little to prevent high differential pressures across the AHU load control valves. In the previous example the load control valve differential pressure varied from 24 kPa at design load to 117.24 kPa at the single chiller, light-load mode of operation.

If it is expected that the light-load differential pressures will exceed the load control valves close-off rating, locate a throttling valve in the common load piping (valve V8 in Figure 78) to reduce the load pressures while still allowing adequate pressure to maintain chiller flows. Select either a double-seated or balanced cage type valve for the high differential pressure.

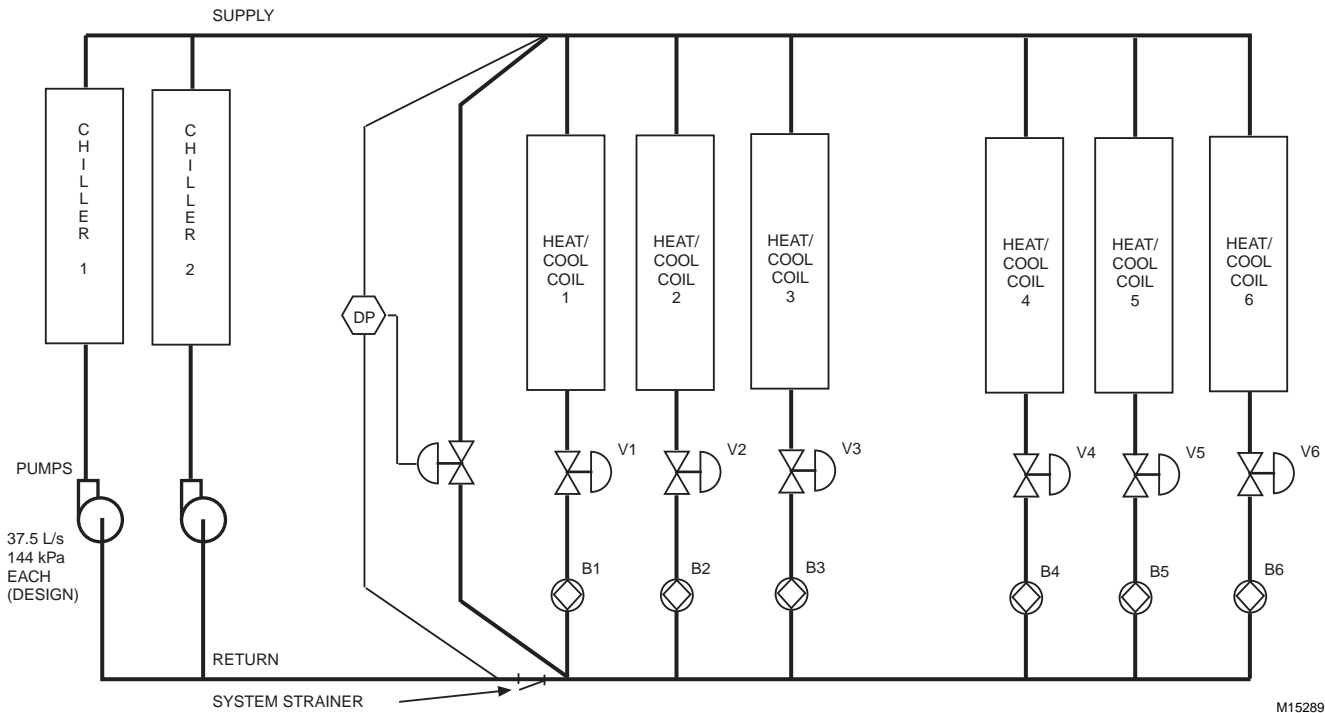

Fig. 77. Dual Pumps, Dual Chillers—Pressure Bypass

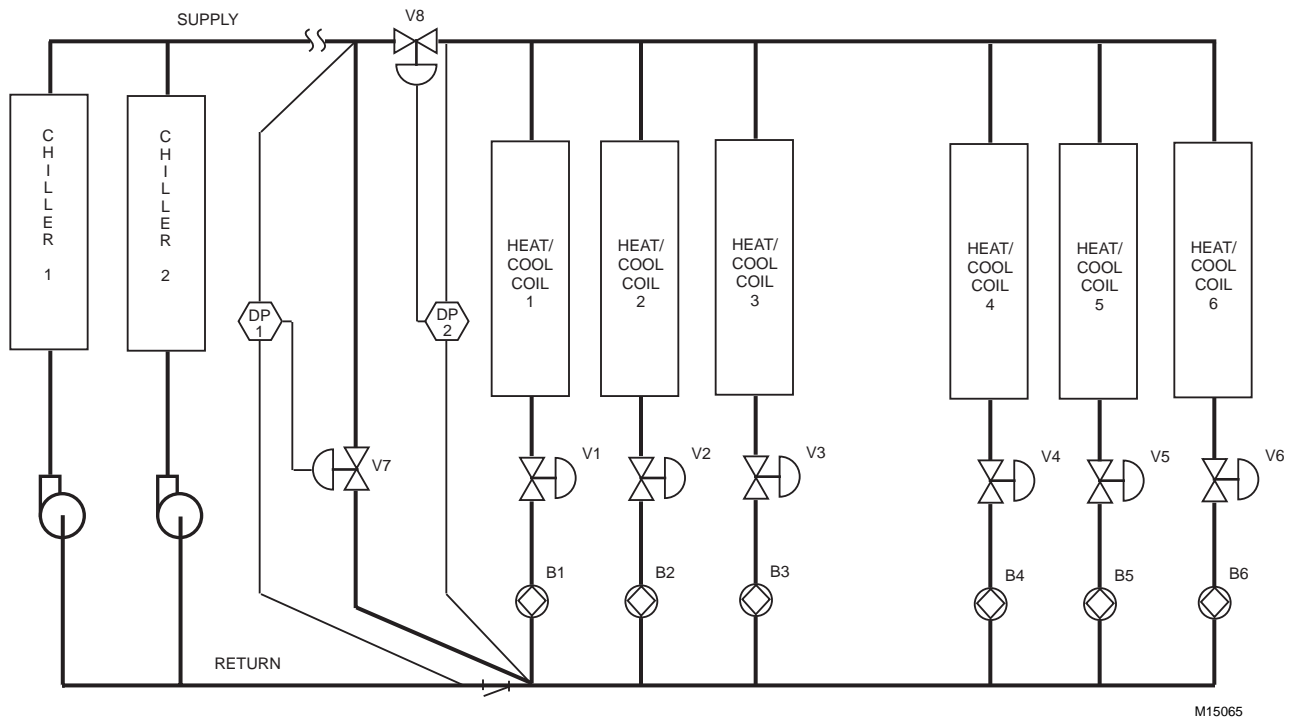

Fig. 78. High AHU Valve Differential Pressure Control

In these examples, the design differential pressure across Load 1 is 84 kPa (Fig. 74), and pressure bypassing occurs at 103.5 kPa. The maximum setpoint for DP-2 (Fig 78) should be about 87 or 90 kPa. This initial setpoint is then slowly lowered based upon the percent-open values of load control valves V1 through V6, to a minimum value of 30 to 36 kPa.

Specification:

Anytime either chiller pump starts, DP-2 shall be enabled to control pressure reduction valve V8 at an initial setpoint of 60 kPa. Anytime any load control valve is greater than 95 percent open, the DP-2 setpoint shall be incremented at the rate of 1.5 kPa every 2.0 minutes up to a maximum of 90 kPa. Anytime all control valves are less than 80 percent open the DP-2 setpoint shall be decremented at the same rate to a minimum value of 36 kPa. All values shall be user adjustable.

Specification Discussion:

The value of 2.0 minutes in the specification assumes that valves V1 through V6 are controlled from discharge air temperature and should recover in less than 2 minutes from V8-caused changes. If V1 through V6 were controlled from space temperature directly, the time rate for V8 adjustments may need to be extended to 12 to 15 minutes to allow incremental space temperature control recovery from the flow reductions brought about by V8. Valve V8 is normally open and line size to minimize its pressure drop during full load

operation. This valve is applicable for direct or reverse return piping configurations where significant piping friction losses migrate out to the control valves upon low flow conditions.

In reverse return systems, locate Valve V8 in the main line piping just before the AHU 1 takeoff and the DP-2 sensor across AHU 1 set for approximately 57 kPa, this should be adequate for any variation in uneven loading. Allow 57 kPa for close-off and good control. Resetting the DP-2 setpoint lower is unnecessary in this constant-speed pumping reverse return example.

VARIABLE SPEED PUMP CONTROL

Decoupled Variable Speed Pump Control, Direct Return

Similar to Figure 74, Figure 79 decouples the loads from the source pumps and heat exchangers and uses of a variable speed pump to provide significant energy savings at reduced loads and simpler control. Variable speed pump control matches pump speed to system flow demands. If source devices perform well with variable flow, the primary pumps may be replaced with variable speed pumps and controlled similarly to the decoupled example.

NOTE: The variable speed pump pressure is only 108 kPa since the primary pumps account for the 36 kPa chiller pressure drop.

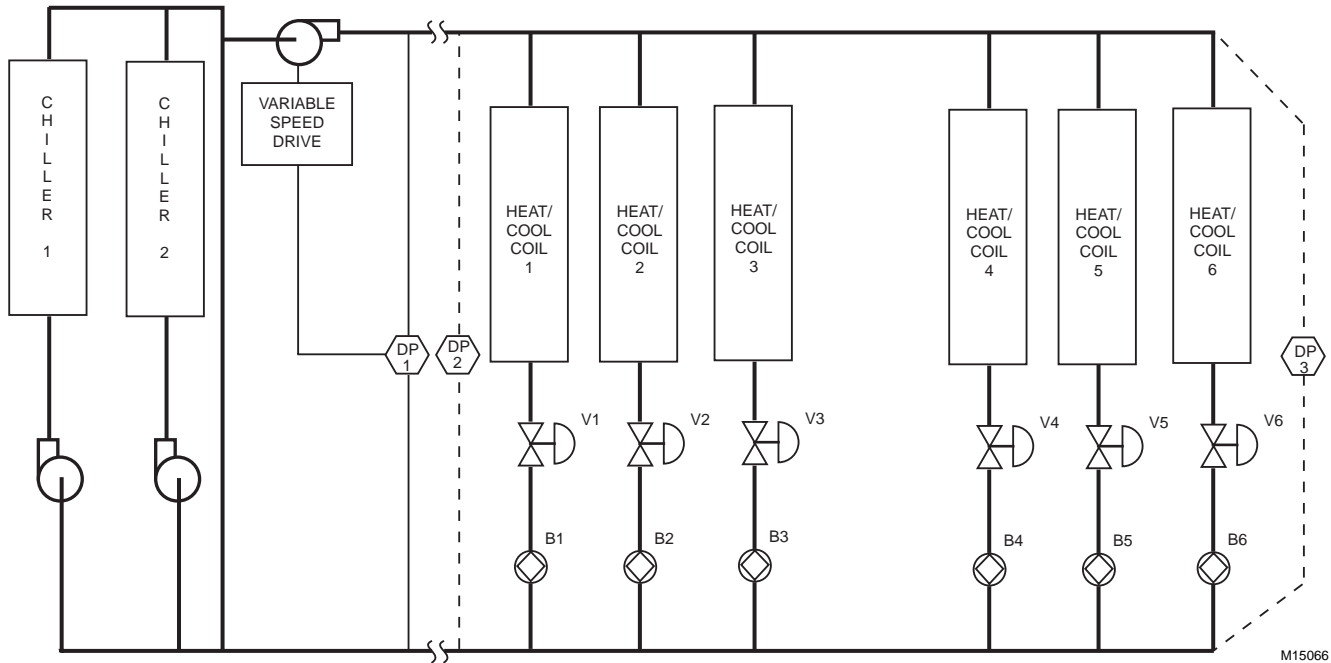

Fig. 79. Variable Speed Pump Control

AHU 1 requires a 84 kPa differential pressure (24 kPa for the coil, 24 kPa for the valve, and 36 kPa for the balancing valve), for full flow. If 84 kPa is available at AHU 1, all other AHUs will have at least the required design differential pressure. Controlling the pump with a sensor positioned as shown for DP-2 set for 84 kPa is acceptable.

Locating the sensor (DP-3) at AHU 6 and set for the 48 kPa required by AHU 6 will not work when only AHU 1 is operating. With these conditions DP-3 maintains a maximum drop of only 48 kPa across AHU 1 which needs a 84 kPa differential pressure because of the balancing valve. If the sensor is positioned at AHU 6, the setpoint must still be 84 kPa if the system is to operate satisfactorily with non-symmetrical loading.

DP-1 located at the variable speed drive (VSD) is the most convenient place. It requires the DP-2 setpoint plus the friction losses between the pump and AHU 1.

Figure 80 shows the operating curve of the system with the differential pressure sensor located in the DP-2 position and set for 84 kPa. With each AHU at one-third flow, the speed is 1412 RPM, which produces a 84 kPa differential pressure at AHU 1 with 25 L/s system flow. When the coils are equally loaded at one-third flow, each control valve takes a 78 kPa drop. In this configuration the pump never operates much below the 1400 rpm speed because of the 84 kPa setpoint.

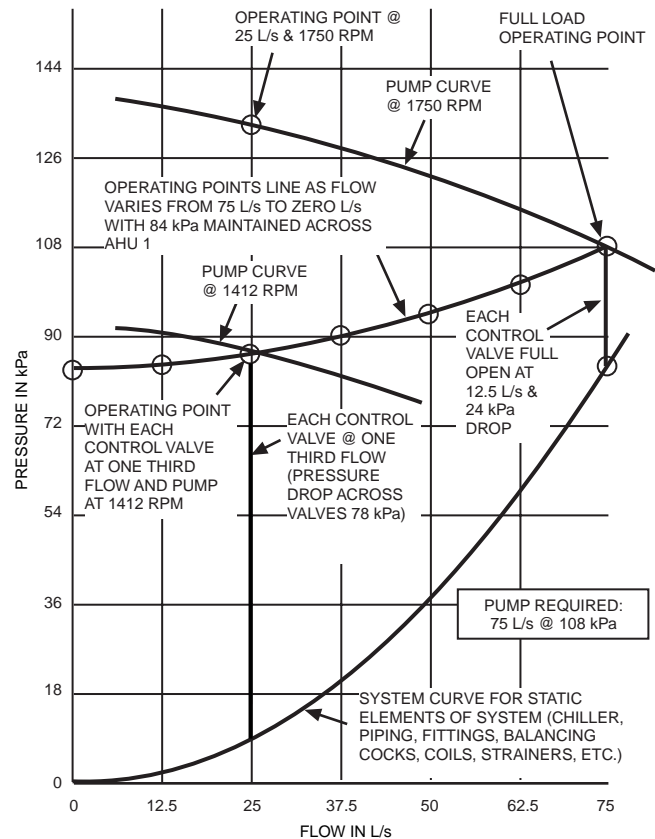

Fig. 80. Fixed Setpoint with PI, Variable Speed Pumping Control

No pump pressure control example, so far, takes advantage of both the variable speed pump and a digital control system. The digital control system VSD control algorithm adjusts the differential pressure setpoint based on the demands of all the valves (Fig. 81) and all loads are satisfied with significant savings over any of the three fixed setpoint options. Since, when using valve position load reset there is no difference in performance between the three locations, DP-1 is preferred because of initial cost. Valve position load reset provides adequate control performance whether the sensor is only proportional or is only a static pressure sensor as compared to a differential pressure sensor.

Specification:

Anytime any AHU chilled water valve is greater than 15% open for greater than one minute, the secondary pump shall be started under EPID control at 20% speed and with a ramp duration of 120 seconds. The pump VSD shall be controlled by a differential pressure sensor located between the supply line leaving the plant room, as far from the pump as practical to avoid hydronic noise that may be present at the immediate pump discharge, and the system return line. At start-up the differential pressure setpoint shall be 90 kPa (See Note 1). Anytime any load control valve is greater than 95% open, the differential pressure setpoint shall be incremented at the rate of 1.5 kPa every minute up to a maximum value of 114 kPa. Anytime all load control valves are less than 80% open, the differential pressure setpoint shall be decremented at the same rate down to a minimum of 21 kPa. After 12 minutes, the increment/decrement rate shall be changed from one minute to three minutes (See Note 2). All values shall be user adjustable.

NOTES:

1. From Figure 81, pump pressure is 108 kPa if all AHUs require full flow, therefore, the 90 kPa value is an arbitrary compromise.
2. This relaxes the control demands for smooth stability after the response to the initial load.

Figure 81 shows the ideal performance of the load reset setpoint control with each AHU demanding one-third flow. All control valves are full open and the differential pressure adjusted to produce a speed of 525 RPM. If the coil loading is non-symmetrical to the point that AHUs 1 and 2 are fully loaded while the others are off, the operating point for 1/3 system flow is the same as shown in Figure 80 for 1/3 system flow, since AHU 1 requires a differential pressure of 84 kPa for full flow.

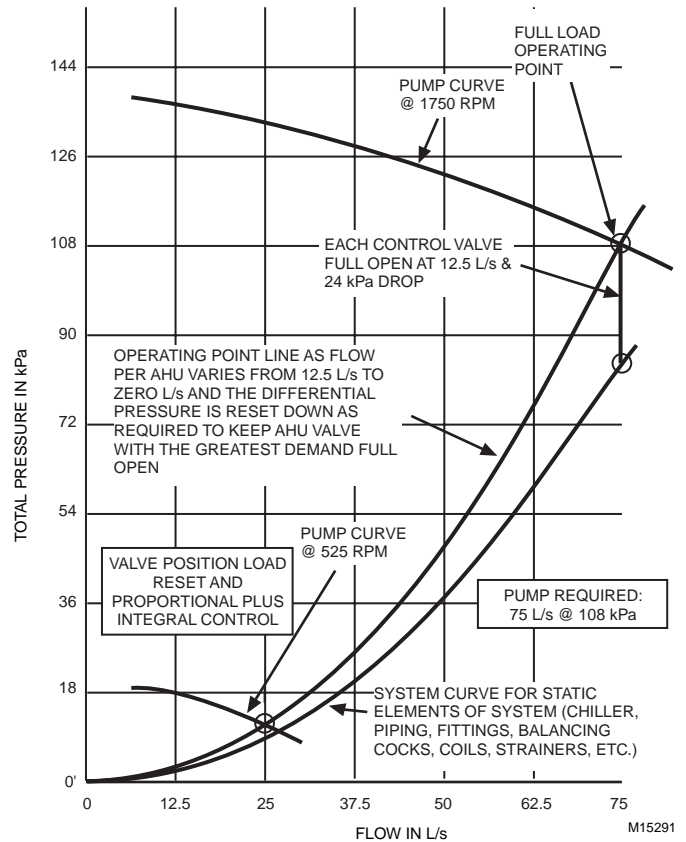
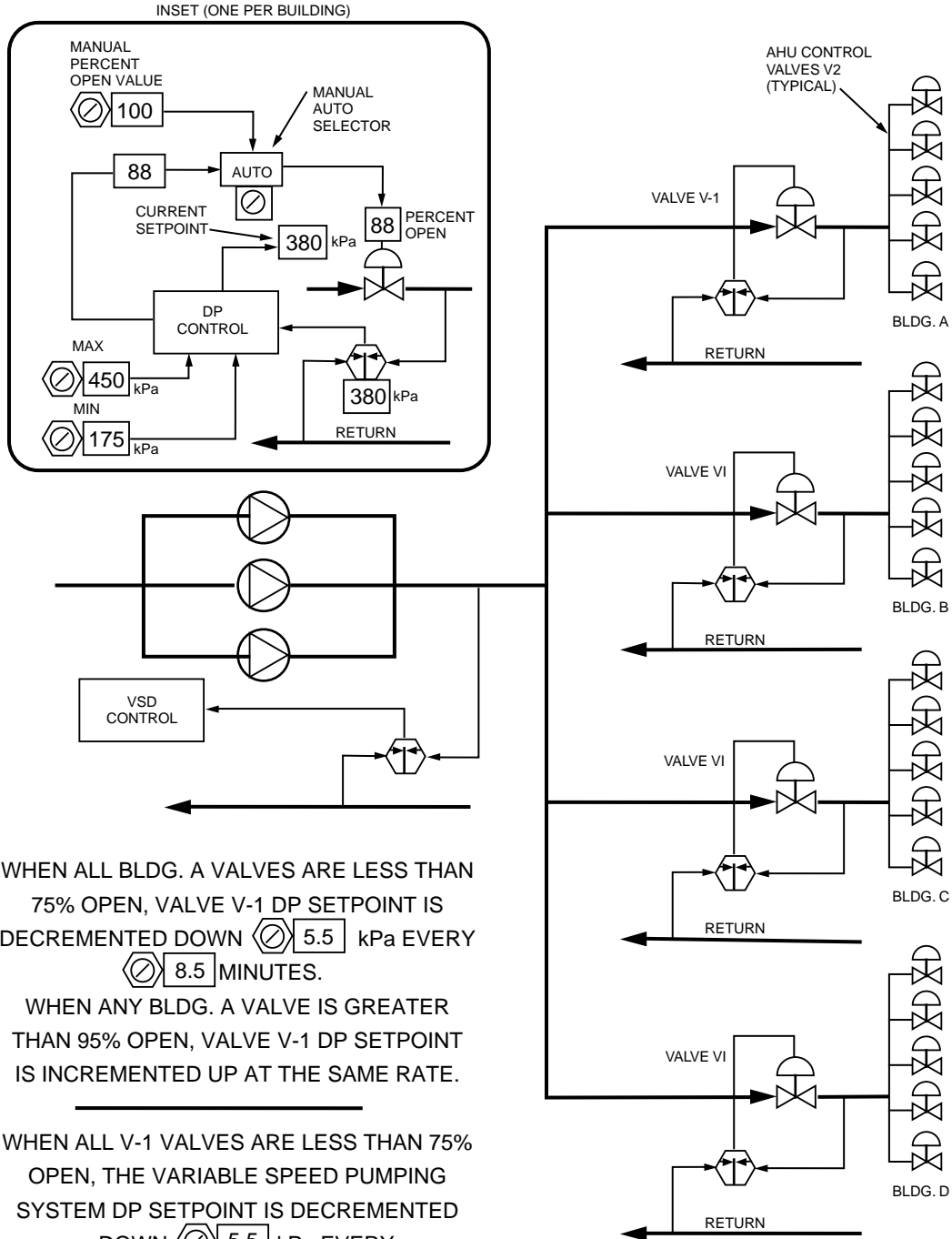

Fig. 81. Variable Setpoint, Variable Speed Pumping Control (Ideal Curve).

Pump Speed Valve Position Load Reset

A pump speed valve position load reset program with over 20 valves can become cumbersome. Also, if any one valve, for whatever reason, stays open most of the time, then the load reset program becomes ineffective. Figure 82 shows an example of the valve position load reset program concept applied to a multibuilding facility with varying differential pressures entering each building, due to varying distances from the pumping plant. The example address two issues, differential pressure control within each building to relieve control valves from extremely high differential pressures and pump speed load reset.

MULTI-BUILDING VARIABLE FLOW CONTROL CONCEPTS



WHEN ALL BLDG. A VALVES ARE LESS THAN 75% OPEN, VALVE V-1 DP SETPOINT IS DECREMENTED DOWN \odot 5.5 kPa EVERY \odot 8.5 MINUTES.

WHEN ANY BLDG. A VALVE IS GREATER THAN 95% OPEN, VALVE V-1 DP SETPOINT IS INCREMENTED UP AT THE SAME RATE.

WHEN ALL V-1 VALVES ARE LESS THAN 75% OPEN, THE VARIABLE SPEED PUMPING SYSTEM DP SETPOINT IS DECREMENTED DOWN \odot 5.5 kPa EVERY \odot 8.5 MINUTES.

WHEN ANY V-1 VALVE IS GREATER THAN 95% OPEN, VALVE V-1 DP SETPOINT IS INCREMENTED UP AT THE SAME RATE.

M15292

Fig. 82. Multibuilding, Variable Speed Pumping Control.

Each building is provided with a “choke” valve (V-1), and a load reset loop to maintain water pressure within the building, such that the most demanding AHU valve is always between 80 and 95 percent open. Each building requires a Valve V-1 Control Detail (inset) and a dynamic sequence description of the program. Each control detail includes minimum and maximum differential pressure setpoints, a software MANUAL - AUTO selector, and a setpoint value for the manual position. Ideally the control detail along with the current percent open for each valve within the building is provided graphically for each building.

NOTE: If the choke valve (V-1) is omitted on the most remote building, the choke valves need not be considered for pump sizing.

Pump speed is reset to keep the most demanding Building Valve V-1 between 80 and 95 percent open.

Adjust balancing valves in buildings close to the pumping plant with the choke valve in control, so that high balancing valve differential pressures are not set to negate low load value of the choke valve reset concept.

This concept can be combined with tertiary pumps in remote buildings to control the building differential pressure and choke valves in closer buildings utilizing central pumping.

Balancing Valve Considerations

BALANCING VALVE EFFECTS

Figure 80 assumes that all coils are equally loaded (1/3 flow), and that all friction losses are 1/9th $[(1/3)^2]$ of their full load value. In symmetrical loading and with valve position reset, the balancing valves have no adverse effect. However, if at 25 L/s total flow, AHU 1 and 2 are operating at full flow (12.5 L/s) and all others are off, the required differential pressure across AHU 1 is 84 kPa, 36 kPa of which is wasted on the balancing valve.

BALANCING VALVE ELIMINATION

Elimination of all balancing valves allows the valve position load reset control strategy to satisfy the non-symmetrical loading described in BALANCING VALVE EFFECTS, by producing only 48 kPa differential pressure at AHU 2 (slightly higher at AHU 1) and save significant pumping energy during most periods of non-symmetrical operation. Before eliminating balancing valves consider:

1. Load coil temperature control setpoints must be strictly maintained. In the example, lowering AHU 1 leaving air temperature 2.5 kelvins below the design temperature causes AHU 1 water flow loop to draw significantly more than design flow because it is nearer the pump where the differential pressure is higher. This will slightly starve the other loads.

2. Cool-down periods for other than AHUs 1 and 2 will be extended. With all valves full open, until AHUs 1 and 2 are satisfied, the other AHUs will be starved.
3. Industrial valves may be required to maintain acceptable controllability. At properly controlled full load design conditions, a 84 kPa differential pressure drop appears across the AHU 1 control valve. This is the 48 kPa differential pressure required at AHU 6 plus the 36 kPa piping drop from AHU 1 to AHU 6. With the high differential pressure, some piping configurations will require an industrial valve.

Elimination of or fully open balancing valves might work well in a continuously operating facility with operators who understand disciplined setpoint and self-balancing concepts.

If eliminating balancing valves in a fixed setpoint scheme, position the DP sensor across AHU 6, with a setpoint of 48 kPa. If AHU 6 is very remote from the VSD pump controller, it is recommended to put an additional differential pressure sensor at the pump with a maximum set point of 108 kPa then reset the setpoint down as required to prevent the AHU 6 differential pressure from exceeding 48 kPa. Use of a DDC PID input and output in separate controllers is not recommended because of the communications system reliability.

If balancing valves are removed in a valve position load reset scheme, use the single differential pressure sensor at the pump with a maximum differential pressure setpoint of 108 kPa.

Differential Pressure Sensor Location Summary

Refer to Figure 79, in summary:

1. If valve position load reset is employed, the DP sensor may be located in the pump room for simplicity (position DP-1)
2. If valve position load reset is not employed and balancing valves are provided, the DP sensor should be located at AHU-1 (position DP 2) and set for 84 kPa
3. If valve position load reset is not employed and balancing valves are not provided, the DP sensor should be located at AHU-6 (position DP 3) and set for 48 kPa.
4. If the sensor is located at AHU 6, resetting the setpoint of a sensor located at position DP 1 is recommended as noted in BALANCING VALVE CONSIDERATIONS.

Pump Minimum Flow Control

Pumps require a minimum flow to dissipate the heat generated by the pump impeller. A bypass around the pump located out in the system provides the required flow and prevents the heat from building up in the pump. The minimum flow is calculated from the equation:

$$\text{Minimum flow (L/s)} = \frac{\text{kW}}{4.2 \times \Delta T}$$

Where:

ΔT = Low flow water temperature rise across the pump

The minimum flow for a 7.46 kW pump with a 5 kelvins ΔT (attributed to the pump heating the water) is only 0.37 L/s. The bypass may be fixed or if there is a remote AHU in the 0.75 to 1.52 L/s size, using a three-way valve on that AHU with the bypass in the bypass leg of the three-way valve prevents bypass water from flowing during full-load periods. Another option is an automatic bypass valve programmed to open anytime all AHU control valves are less than 10% open.

Decoupled Variable Speed Pump Control, Reverse Return

In these examples, the design differential pressure for all AHUs is 48 kPa with reverse return, since the balancing-valve drop becomes negligible. If approximately 54 kPa is maintained at AHU 1, design flow is available to all AHUs during any non-symmetrical flow condition. With a reverse return system locate the differential pressure sensor across AHU 1 with a setpoint of 54 kPa. Advantages of valve position load reset are much less with reverse return systems, however, resetting the setpoint from 54 kPa to 24 kPa or 30 kPa based upon load is worthwhile on large systems.

HOT WATER DISTRIBUTION SYSTEMS

GENERAL

Advantages of hot water compared to steam for heat distribution within commercial buildings are:

- Water temperature can be varied to suit variable loads.
- Hot water boilers typically do not require a licensed operating engineer.
- Heat loss from piping is less than steam systems because fluid temperatures are usually lower.
- Temperature control is easier and more stable because water temperature is matched to the load.
- Fewer piping accessories to maintain than steam systems.
- Reduced air stratification at light loads with reset hot water.

The control objectives for a hot water distribution system providing space heating are:

1. Provide adequate hot water flow to all heating units.
2. Maintain a stable pressure difference between supply and return mains at all load conditions.
3. Match hot water temperature to the heating load based on outdoor air temperature and/or occupancy.
 - a. Avoid heat exchanger flow velocities dropping into the laminar range.
 - b. Keep water velocities up to prevent freezing.
 - c. Reduce mixed air temperature stratification.
 - No stratified cold air to trip low temperature controllers or cause freeze-up.
 - Minimizes stratified air from having adverse effects on coil discharge temperature sensing.
 - Minimizes possibilities of hot air flowing out some duct outlets and cold air flowing out others.

Refer to METHODS OF CONTROLLING DISTRIBUTION SYSTEMS for additional information on control objectives.

HOT WATER CONVERTERS

A hot water converter uses either hot water or steam to raise the temperature of heating system water to a temperature which satisfies the heating requirements of the system. The most widely used hot water converters use steam.

Steam is often supplied to remote buildings or mechanical rooms from a central plant. Within the buildings or zones, hot water is often preferred because of its ease of control. Steam to water converters are used for these applications.

A converter consists of a shell and tubes. The water to be heated passes through the tubes. Steam or hot water circulates in the shell around the tubes. Heat transfers from the steam or hot water in the shell to the heating system water in the tubes.

If the pressure on the water in a converter drops below the vaporization pressure for the temperature of the water, the water can flash to steam. Pumps are usually located on the return side of the converter to provide a positive pressure and minimize flashing.

Figures 83 and 84 show commonly used controls for hot water converters. See HOT WATER RESET for converter control.

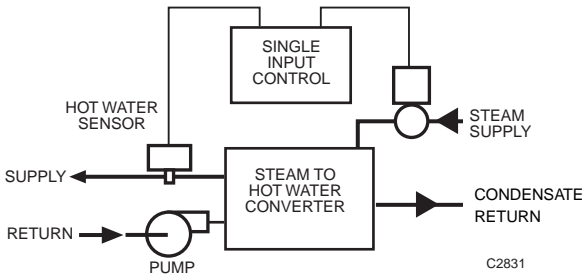

Fig. 83. Constant Temperature Hot Water Converter Control.

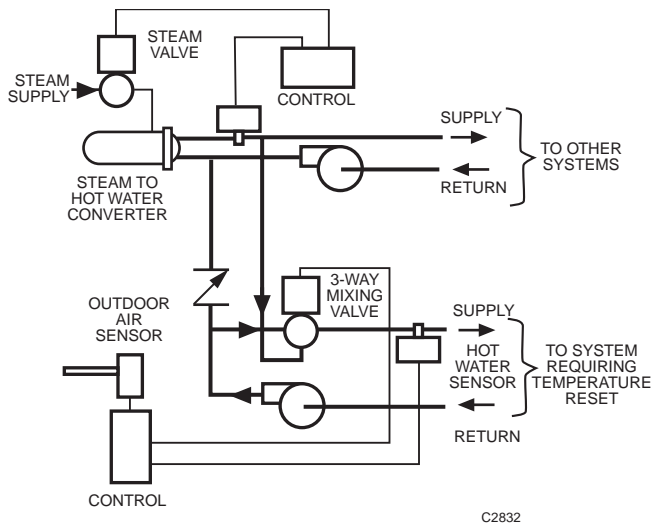

Fig. 84. Hot Water Converter Control with Constant Temperature and Reset Zones.

HOT WATER PIPING ARRANGEMENTS

General

Hot water piping systems use one- or two-pipes to deliver the water to the terminal units. The one-pipe system shown in Figure 85 uses flow diverting fittings to scoop water out of the single loop into each radiator or baseboard radiation section. Another fitting returns the water to the main where it is mixed with the supply water. The next unit will be supplied with slightly lower temperature water. One-pipe systems are typically used in small buildings with only one or two zones.

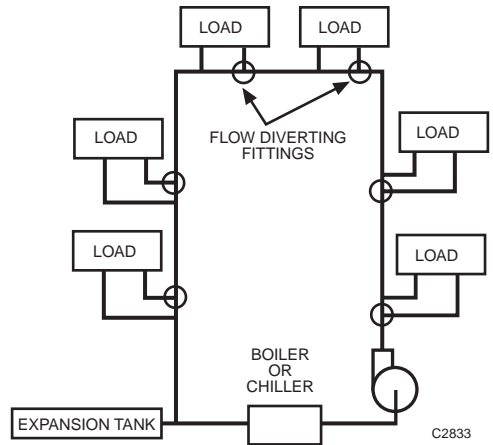

Fig. 85. One-Pipe System.

Figure 86 shows a two-pipe reverse-return system. The length of supply and return piping to each terminal unit is the same, making the system self-balancing. The reverse-return is used in large or small installations.

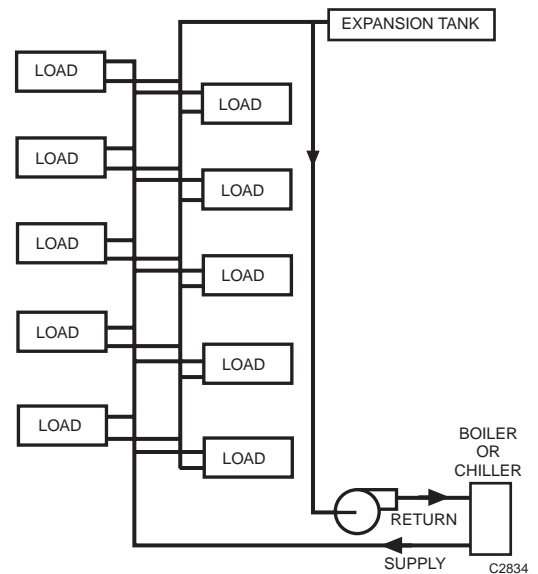

Fig. 86. Two-Pipe Reverse-Return System.

Figure 87 shows a two-pipe direct-return system. The direct-return system is used on small systems. The shorter return piping reduces installation cost but each load loop must be symmetrical.

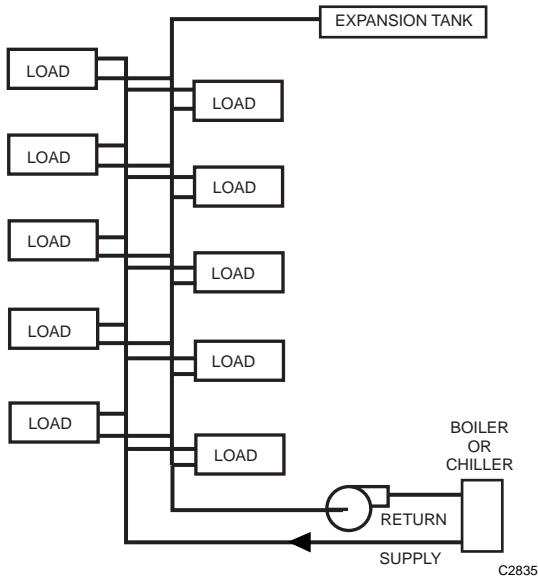

Fig. 87. Two-Pipe Direct-Return System.

Primary-Secondary Pumping

Primary-secondary pumping allows water temperature and on/off times of each secondary zone to be independently controlled. The main supply pump uses less power in this arrangement since it is sized to handle only main pressure losses. Secondary pumps handle only the zone piping losses.

Figure 88 shows common configurations for primary-secondary pumping. The three-way valve configuration provides more positive control than the two-way valve.

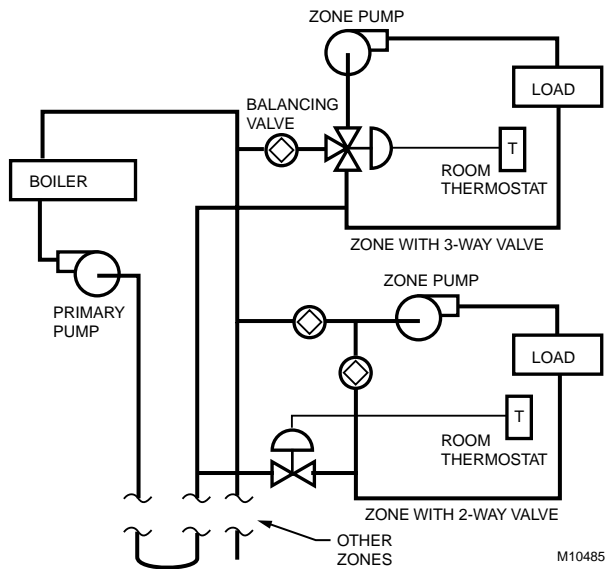

Fig. 88. Piping for Primary-Secondary Pumping.

A converter (heat exchanger) shown in Figure 89 can be used in large or high rise buildings to reduce the zone temperature/pressure requirements from those of the mains.

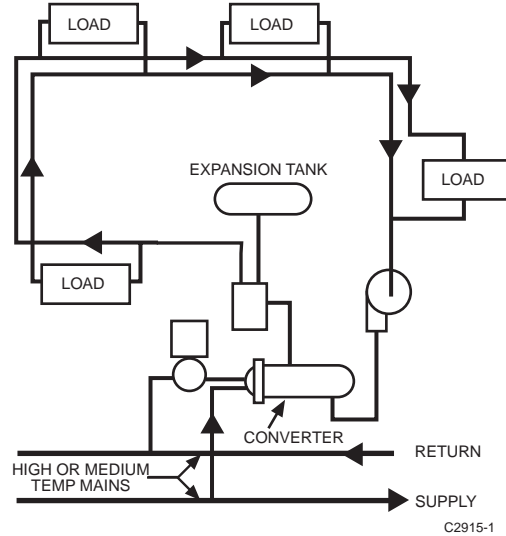

Fig. 89. Converter Used to Supply Zones from a Larger System.

CONTROL OF HOT WATER SYSTEMS

General

Heating (terminal) units used in hot water heating systems are:

- Radiant Panels
- Radiators or finned tubes
- Forced air heating coils

Control of heat output from a heating unit can use one or a combination of the following methods:

- On-off control, by starting and stopping a pump or opening and closing a valve
- Modulating flow control
- Supply water temperature control

Modulating Flow Control

Varying water flow to finned tube radiation or a heating coil, each supplied with constant temperature hot water, is shown graphically in Figures 90 and 91.

In both cases, reducing flow 75 percent reduces the heat output only 30 percent because as flow is reduced, more heat is extracted from each liter of water. At low flows leaving water temperature decreases sharply (Fig. 91). At light loads modulating flow control by itself is not the best means of controlling heat output.

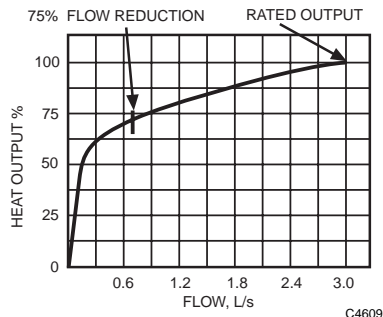

Fig. 90. Effect of Flow Control on Finned Tube Radiator Heat Output.

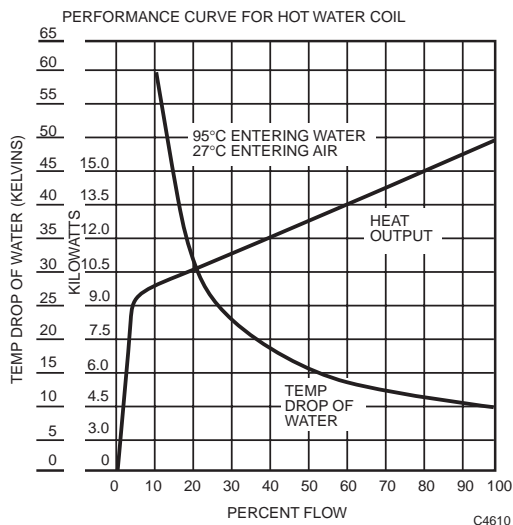

Fig. 91. Effect of Flow Control on Hot Water Coil Heat Output.

Supply Hot Water Temperature Control

If supply water temperature is varied (reset) in response to a change in heating load, heat output varies almost linearly (Fig. 92). This mode of control appears ideal, except that it is impractical to provide a different hot water temperature to each heating coil or piece of radiation in a building. Varying supply water temperature as a function of outdoor temperature provides a good compromise.

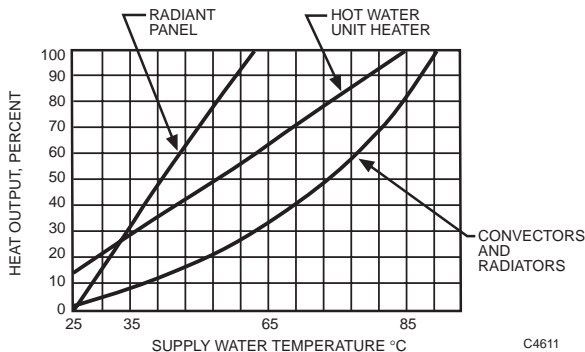

Fig. 92. Supply Water Temperature vs Heat Output at Constant Flow.

Supply Hot Water Temperature Control With Flow Control

Combining flow control with supply water temperature reset from outdoor air temperature or any other measurement of load results in effective control.

Figure 93 shows output of a typical air heating coil with flow and supply water temperature control. When 43°C water is supplied during light load conditions, the maximum air temperature rise through the coil is only 5 kelvins. With the proper water temperature reset schedule, the control valve stays in the 30 to 100 percent open range where flow control output is linear. Thus, radical changes from desired output do not occur. This is true for radiators, finned tubes, and reheat coils.

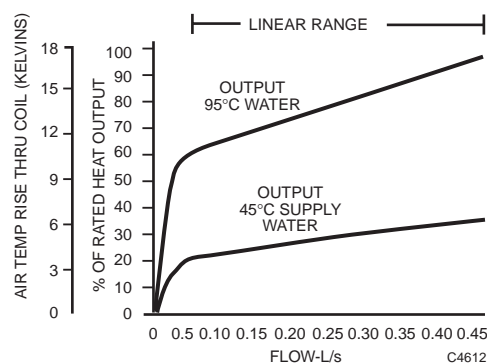

Fig. 93. Heat Output of Hot Water Coil at Two Supply Temperatures.

Hot Water Reset

As previously discussed, reset of hot water supply temperature is the most effective method of controlling heat output of a water supplied heating coil, panel, radiator, or convector. Heat output of most water supplied heating is relatively linear with respect to supply water temperature. Water temperature reset can be provided by a steam to hot water converter, a three-way valve, or boiler water temperature reset. Reset of hot water using a steam to hot water converter is discussed in this section.

HOT WATER CONVERTER

The supply water temperature to the radiant panel (Fig. 94) is reset by the controller modulating a valve in the converter steam supply. The controller uses the temperatures at the outdoor air sensor and the supply water sensor to control the steam supply valve. The valve is positioned to maintain the converter discharge water temperature as determined by the reset schedule and outdoor air temperature. A typical reset schedule is shown in Table 5.

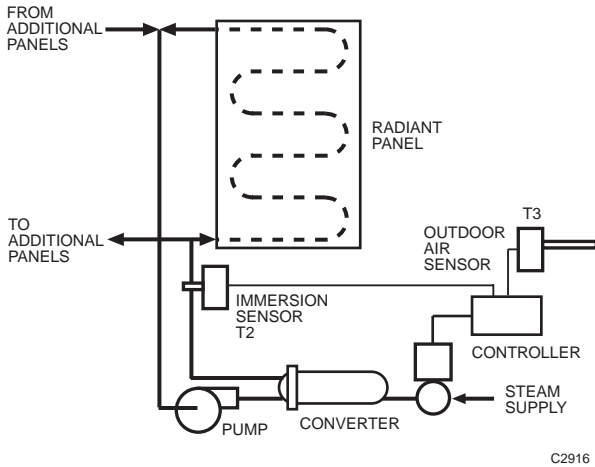

Fig. 94. Radiant Panel with Scheduled Water Temperature Using Converter.

Table 5. Typical Hot Water Reset Schedule.

OA Temperature	Water Temperature
21°C	27°C
2.0°C	38°C
20°C	50°C

Before determining a digital converter control scheme, two issues must be explored; the nature of the hot water load and the steam source.

If the load is affected by the OA temperature, then an appropriate reset schedule should be used. If the load has a step change, such as going from a warm-up mode (no sun, no people, no lights or internal heat load) in the early morning; to the occupied mode (lights, people, office equipment, sun) at a specific time, then the reset schedule should also shift from a high temperature reset schedule hot water during the warm-up mode, to a low temperature reset schedule as the occupied loads come into effect.

If the heating load includes 100 percent OA preheat coils, special care must be given to assuring high water flow rates through the coil when the OA temperature is below freezing. Preheat coil valve-position reset of hot water temperature could be applied such that anytime the OA temperature is below freezing, the hot water temperature setpoint can be lowered as required to keep the most demanding preheat coil hot water valve greater than 85 percent open, and raised incrementally anytime any valve is greater than 95 percent open. This can be accomplished via applying (incrementing) a multiplier of 0.75 to 1.25 to the OA reset schedule-derived setpoint. Setpoint calculations should complement the objectives of the AHU optimum start programs.

Another digital control function is steam valve demand limiting. Water systems are usually balanced such that if all water valves are full open, design flow is delivered to all load coils (unless diversity is used). Steam systems are usually not balanced. From size-to-size, control valve capacities typically increase about 35 percent, for example DN 40 valve, $K_v = 25$; to DN50 valve, $K_v = 40$. When steam valves are sized and valve selections are rounded up to the next larger size, on the average they are about 17 percent oversized (and worse case more than 30 percent oversized). If a valve with a K_v of 40 is furnished for a load requiring a K_v of 30 and the oversizing has a negative impact on the steam source, software can "destroy" the control valve. A destroyed valve has the maximum stroke reduced, such that as the load varies from 0 to 100 percent, the oversized valve is positioned from 0 to 75 percent open. Destroyed valves may be specified to display their actual stroke percent open or to display 0 to 100 percent open as the valve varies from 0 to the destroyed maximum position (destroying is normally transparent to HVAC system operators).

When hot water converter loads are scheduled (shut down at night and started in the morning), the morning start-up is usually greater than 100 percent load every morning because the hot water has cooled down such that the steam valve starts full open. In mild weather, when the actual load may be only 15 to 20 percent, this momentary 100 percent plus start-up demand causes boilers to surge up to full capacity (or in a multiple boiler system to stage multiple boilers on) only to unload down to the operating load of 15 to 20 percent. Digital systems can be programmed such that as the OA temperature varies from 16°C to -9.5°C, the maximum start-up steam valve positions vary from 20 to 100 percent (this start-up destroying limit could be removed at 0900).

Common practice on large converters provides two parallel piped steam control valves (usually sized for 1/3 and 2/3 capacity) such that the small valve handles light loads (preventing a single large valve from throttling down to the point where the valve plug approaches the valve seat where noise and seat erosion occur) and the large valve is sequenced in after the small valve is full open. At the point where the 2/3 sized valve starts opening, the same noise and erosion is possible.

With digital systems, the valves may be staged (rather than sequenced) such that as the load varies 0 to 33 percent, the small valve modulates from 0 to full open, and as the load varies 33 to 66 percent, the small valve closes and large valve modulates from 50 percent to full open, and as the load varies 66 to 100 percent, both valves modulate in unison from 2/3 to full open.

The following converter control example is for a dual valve converter with demand limiting and a warm-up shifted temperature reset schedule.

Dual Valve Converter, Demand Limiting, Setpoint Shift

Functional Description

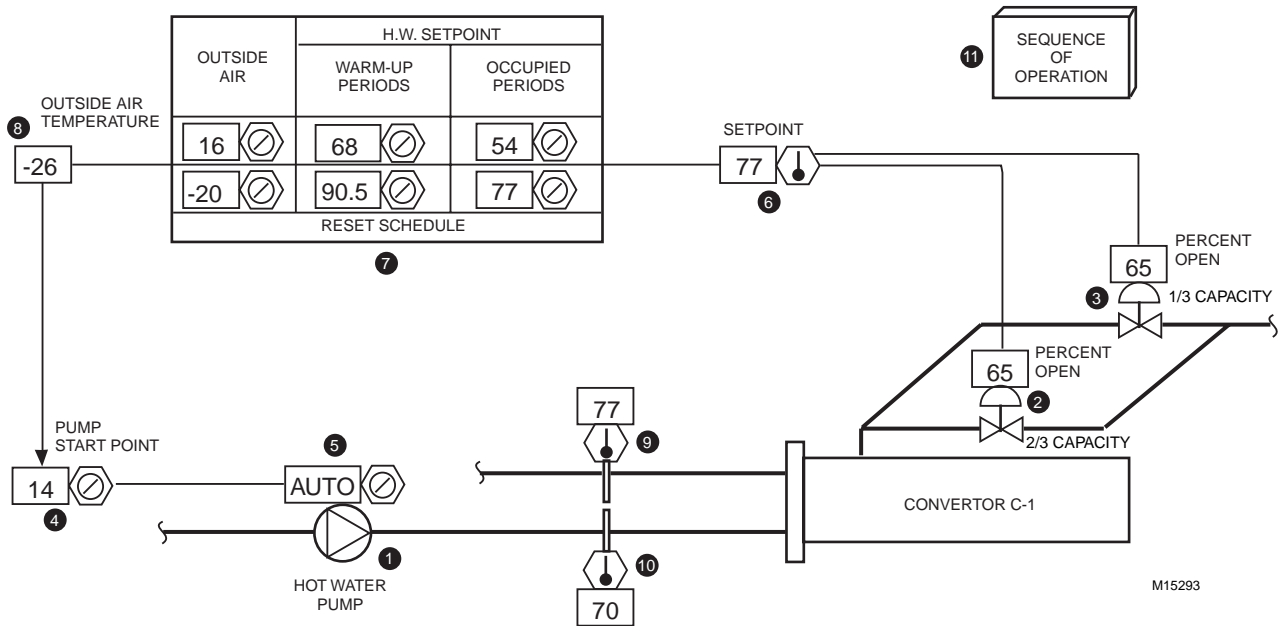

Fig. 95. Dual Valve Converter, Demand Limiting, Setpoint Shift Graphic.

Item No.	Function
1	Dynamic pump symbol. Pump starts on drop in OA temperature.
2,3	Steam valves staged for hot water temperature control.
4,5	Pump runs below OA temperature setpoint, subject to ON-OFF-AUTO selector.
6-8	Hot water temperature setpoint varied by dual reset schedule as OA temperature varies.
9	Controlled leaving water temperature.
10	Entering water temperature, operator information.
11	Icon, selects the sequence of operation text display.

Features

1. Staged 1/3 - 2/3 capacity control valves.
2. Dual reset schedule to accommodate the warm-up mode and occupied periods.
3. Demand limiting to prevent the converter from exceeding its required capacity when controls demand full load.

Conditions For Successful Operation

1. Technicians and users capable of understanding and tuning the control strategy.
2. Proper settings and timings of all control parameters.

Specification

Converter Control:

Anytime the pump does not prove operation, the converter valves shall close.

Control:

The control system shall be enabled anytime steam pressure is available. The hot water pump shall start anytime the OA is below 14.5°C, subject to a software on-off-auto command.

Control:

During early morning periods (AHUs in warm-up mode) the hot water (HW) temperature setpoint shall vary from 68°C to 90.5°C as the OA varies from 16°C to -20°C. During occupied periods (any AHU in occupancy mode) the HW temperature setpoint shall vary from 54°C to 77°C as the OA varies from 16°C to -20°C. Setpoint warm-up to occupied period switching shall be ramped such that the change occurs over a 15-minute time duration. A PID function shall modulate the hot water valves as required to maintain the setpoint.

Staging:

Two normally closed valves shall be provided with Kvs of 25 and 63. On a demand for heating, the small valve shall modulate open. Upon demand for steam beyond the capacity of the small valve for a period of five minutes, the small valve shall close and the large valve shall assume the load. Upon a demand for steam beyond the capacity of the large valve for a period of five minutes, the small valve shall be re-enabled and both valves shall operate in unison, but with a combined capacity not to exceed the capacity noted in Demand Limiting.

With both valves operating, as the total demand drops below the capacity of the large valve for five minutes, the small valve shall close. With the large valve operating, as the demand drops below the capacity of the small valve for five minutes, the large valve shall close and the small valve shall assume the load.

Demand Limiting:

A large valve Kv limiting parameter shall be provided and set such that upon full demand, the valve Kv shall not exceed the design Kv of 51.

All valve timings and parameters shall be field adjustable by the owner.

THREE-WAY VALVE

The supply water temperature to the radiators (Fig. 96) is reset by the controller modulating the three-way valve. The controller modulates the three-way valve to maintain the reset schedule in response to temperature changes at the outdoor air sensor and the supply water sensor. Pump runs continuously during the heating season. As water temperature changes, the heat output changes linearly. This allows accurate changes in heating plant capacity as a function of outdoor air temperature or some other signal to match the load.

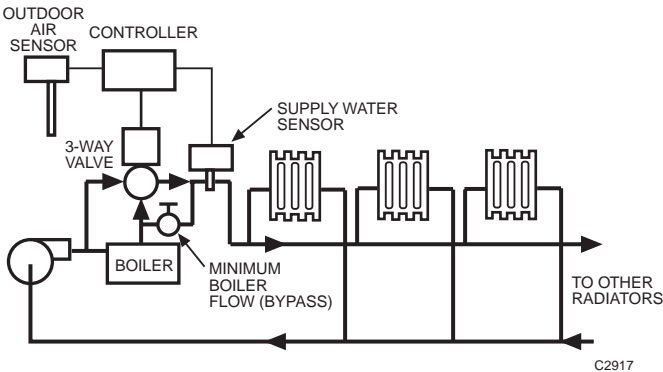

Fig. 96. Radiators with Scheduled Water Temperature Using Three-Way Valve.

Coordinating Valve Selection and System Design

A prerequisite to good modulating control of water systems is a coordinated design of the entire water system. All control valves must be sized so that the system will deliver design flow at full load and not generate uncontrollable conditions at minimum load.

Control valve selection is based on pressure differentials at the valve location, full load flow conditions, valve close-off, and valve controllability at minimum load conditions.

Generally, for smooth modulating control, the no-flow pressure differential should not exceed the full flow differential by more than 50 percent.

Hot Water Control Method Selection

Supply water temperature control is suitable for controlling the heat delivery from a heat exchanger or a secondary water pump.

Flow control is acceptable for controlling individual terminal units such as convectors, fan coils, or induction units. An equal percentage characteristic valve complements the water to air heat exchanger characteristic of heat output versus flow. The result is a relatively linear heat output as a function of stem position (Fig. 97). The heat output is relatively constant, providing optimized controllability of heat exchangers such as converters, fan coils, and induction units.

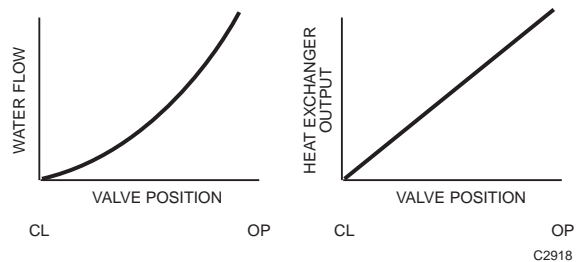

Fig. 97. Control of a Water Heat Exchanger Using an Equal Percentage Characteristic Valve.

CHILLED WATER DISTRIBUTION SYSTEMS

GENERAL

Chilled water systems for cooling of commercial buildings usually provide water between 5°C and 10°C to finned coils in room units or air handlers.

The amount of water delivered to the cooling coils and/or produced by chillers is related to temperature difference (Δt) across the coil or chiller and energy (kilowatts of refrigeration) by the equation:

$$Q = \frac{h}{4.2 \times \Delta t_W}$$

Where:

- Q = Volume flow rate (L/s)
- h = Cooling rate
- Δt = water temperature difference in kelvins
- 4.2 = a constant

EXAMPLE:

Given: A 3.52 kW chiller with a Δt of 6 kelvins.

$$Q = \frac{3.52 \text{ kW}}{4.2 \times 6} = 0.14 \text{ L/s}$$

System Objectives

The chilled water control and distribution system should:

1. Provide the minimum flow of chilled water through the chiller as specified by the manufacturer.
2. Provide a stable pressure difference across supply and return mains.
3. Prevent freeze-up in chiller and/or coils exposed to outdoor air.
4. Control system pumps and bypass valves to prevent short-cycling of pumps or radical pressure changes across control valves at the terminal units.

In addition, for systems with two or more chillers operating at once, the chilled water control and distribution system should:

1. Prevent return water from mixing with chilled water before leaving the chiller plant.
2. Shut off flow through idle chiller(s).

Control of Terminal Units

The heat transfer characteristic is close to linear for a cooling coil (Fig. 98) because the air to water temperature difference is lower than that for hot water coils. This means a valve with either a linear characteristic or an equal percentage characteristic plug is satisfactory.

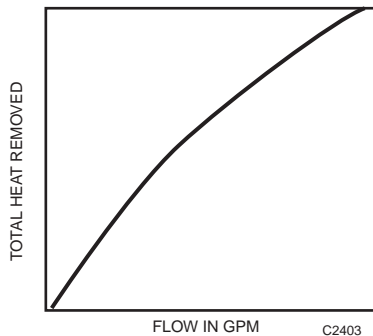

Fig. 98. Typical Heat Transfer Characteristic of a Cooling Coil Supplied with Chilled Water.

DUAL TEMPERATURE SYSTEMS

Figure 99 shows a typical arrangement where the same pipes carry hot water for heating or chilled water for cooling to the same terminal units. These are usually fan coil units.

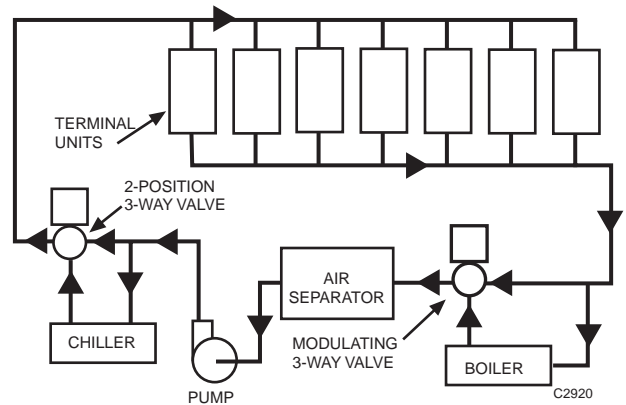

Fig. 99. Two-Pipe Dual-Temperature System.

The three-way valves on the chiller and boiler are used for changeover. The valve on the chiller is controlled two-position. The three-way boiler valve is controlled modulating for heating so that the hot water supply temperature may be reset from the outside temperature. Boiler minimum flow or temperature may require system modifications.

Changeover from heating to cooling can be based on outdoor air temperature, solar gain, outdoor wet-bulb temperature, or a combination. System bypass or other pressure control method may also be required for such systems.

Changeover Precautions

A time delay in changing the operation from hot to chilled water or vice versa is required to avoid putting hot water into the chiller or chilled water into the boiler. A deadband between heating and cooling will usually provide enough delay. Hot water to the chiller can cause the compressor to cut out from high pressure and/or damage the compressor. Chilled water to the boiler can cause thermal shock to the boiler and/or flue gases to condense on the fireside. Protection for boilers is covered in DUAL BOILER PLANT CONTROL. For chillers a maximum entering water of 27°C is required to avoid excessive refrigerant pressure. A thermostatic interlock can provide this safety feature.

MULTIPLE-ZONE DUAL-TEMPERATURE SYSTEMS

Since different zones often have different changeover requirements, it is often necessary to furnish hot water to one zone and chilled water to another, as in a curtain wall building with high solar loads.

Figure 100 uses three-way valves V1 through V4 operating two position to accomplish zone changeover. In large systems, two-way valves may offer a tighter isolation of the hot and chilled water circuits than three-way valves.

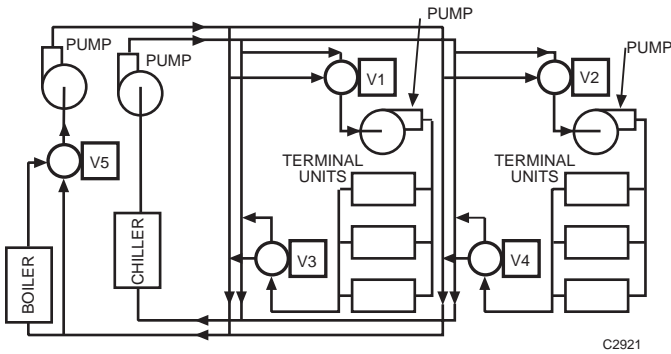

Fig. 100. Two-Pipe Multiple-Zone Dual-Temperature System Using Zone Pumps.

STEAM DISTRIBUTION SYSTEMS AND CONTROL

INTRODUCTION

Steam distribution systems are classified as either low pressure (200 kPa and less) or high pressure (above 200 kPa). Low pressure systems have many subclasses such as one-pipe, two-pipe, gravity, vacuum, and variable vacuum. See **HOT WATER DISTRIBUTION SYSTEMS** for steam-to-hot water converter configurations and control.

ADVANTAGES OF STEAM SYSTEMS VS HOT WATER SYSTEMS

The principle reasons for the use of steam to distribute heat in commercial buildings or in groups of buildings separated from the heating plant are:

- Steam is light weight (1.69 cubic meters per kilogram).
- Steam has high heat content (2325 kilojoules per kilogram).
- Steam flows through pipes unaided by pumps.
- Steam does not create excessive static pressure on piping in tall buildings.
- Terminal units can be added or removed without basic design changes.
- Draining and filling are not necessary to make repairs as with hot water systems.
- Steam can be distributed through a large system with little change in heating capacity due to heat loss.

STEAM SYSTEM OBJECTIVES

Carefully consider distribution system objectives when applying controls either to the boiler or to the distribution system itself. Control and/or piping of the boiler or steam generator are not considered in this section. Not all of Objectives 1 through 7 may apply to any given distribution system.

1. Steam mains must provide adequate capacity so steam velocity is between 40 and 60 meters per second.
2. Water must not be allowed to accumulate in the mains. Provisions must be made for the use of traps or superheated steam to reduce or eliminate water in mains.
3. Pockets of water must not be allowed to accumulate. Steam traveling at 60 meters per second (216 kph) can propel the water causing water hammer, which can damage or destroy piping.
4. Condensate must be returned to the boiler at the same rate as steam leaves the boiler. Otherwise, the boiler will be shut down by low water cutoff control or be damaged from lack of water covering heated metal.
5. Provision must be made to expel the air when steam is again supplied. When any part of the system is not supplied with steam, that part of the system fills up with air from the atmosphere. If air is present with the steam, the air plates the heat exchanger surfaces and reduces capacity. The oxygen in the air causes pitting of iron and steel surfaces and the carbon dioxide (CO₂) in the air forms an extremely corrosive carbonic acid solution.
6. The return condensate piping system must be sized for a low-pressure loss to eliminate flashing. For example, if 200 kPa steam condenses in a heating coil, the condensate is still near the boiling point, say 115°C; and if the return main is at atmospheric pressure, the condensate can flash into steam. This wastes heat and can block the return of condensate to the boiler.
7. If necessary, the flow of steam must be accurately measured to account for steam usage. When steam is used in a closed system (none is vented to atmosphere), the steam flow to a building or zone can be measured by measuring condensate flow.

PROPERTIES OF STEAM

Adding 4.2 kilojoules to one kilogram of water raises the water temperature one kelvin. When water temperature reaches 100°C at sea level (101.325 kPa) it contains (100 – 0) x 4.2 = 420 kJ/kg. However, it takes another 2275 kJ to convert the one kilogram of water to a vapor (steam). The total heat of the vapor is: 420 kJ/kg + 2257 kJ/kg = 2677 kJ/kg. The 2257 kJ/kg is the latent heat required to vaporize water.

One kilogram of water in the liquid state occupies about 0.001 cubic meters at 0°C. When converted to vapor at 100°C, it occupies 1.673 cubic meters or 1673 times as much space as the liquid.

One kilogram of steam (water vapor) when cooled and condensed in a radiator or other heating device gives up 2257 kJ to the device and returns to its liquid state. If the liquid (water) leaves the radiator at 82°C, it gives up another 74 kJ, so the total heating value of low pressure steam is said to be 2325 kJ/kg per kilogram (actually 74 + 2257 or 2331 kJ/kg).

STEAM SYSTEM HEAT CHARACTERISTICS

Figure 101 shows the characteristics of one kilogram of steam as it travels through a steam heating system.

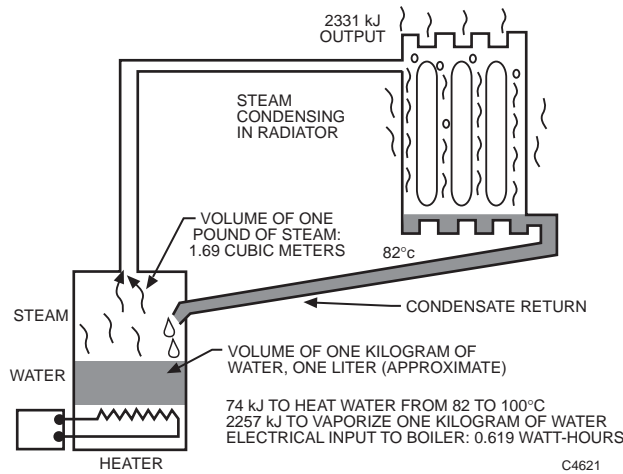

Fig. 101. One Kilogram of Water in a Steam Heating System.

STEAM PRESSURE, TEMPERATURE, AND DENSITY

Steam temperature is directly related to pressure, see Table 6. For a more extensive table refer to the General Engineering Data section. Note that density, which is the reciprocal of specific volume, increases sharply with pressure, while total heat per kilogram remains relatively constant.

Table 6. Approximate Values for Properties of Saturated Steam.

Pressure in kPa (absolute)	Temperature Saturated °C	Density, kilograms per Cubic Meter	Latent Heat of Vaporization, kJ/kg	Total Heat kJ/kg
100	99	0.59	2257.9	2675.4
150	111	0.86	2226.2	2693.4
800	170	4.16	2046.5	2667.5
1600	201	8.08	1933.2	2791.7

This table illustrates that in a given size pipe more than four times as much steam can be carried with steam at 800 kPa as with steam at 150 kPa. However, a 800 kPa steam main is 59°C hotter than 150 kPa steam.

EXAMPLE:

The heat in 50m³ of steam:

$$\begin{aligned} \text{at 150 kPa is } & 43 \text{ kg} \times 2693 \text{ kJ/kg} = 115\,799 \text{ kJ} \\ \text{at 800 kPa is } & 208 \text{ kg} \times 2668 \text{ kJ/kg} = 554\,944 \text{ kJ} \end{aligned}$$

STEAM QUALITY

Steam tables generally show properties of dry-saturated steam. Dry-saturated steam has no entrained moisture and is at the boiling point for the given pressure. Dry-saturated steam is said to have 100 percent quality. Steam produced in a boiler usually has some water droplets entrained in the steam and is called wet-saturated steam. Condensation collecting within steam mains can also become entrained and lessen steam quality. If 10 percent of the steam weight is liquid, the steam has 90 percent quality.

If steam has 85 percent quality and if 0.1 kg/s is needed through a pipe or valve, then $0.1/0.85 = 0.118$ kg/s of the 85 percent quality steam is required.

Superheated steam is steam at a temperature above the boiling point for the indicated pressure. It can be produced by passing the saturated steam through a superheater. A superheater consists of steam tubes exposed to hot gases from the firebox. This steam is hotter than the temperature listed in steam tables. Superheat is expressed in degrees Fahrenheit or Celsius (kelvins). Since superheated steam has a higher heat content per kilogram, the steam quantity needed through a pipe or valve is reduced.

Pressure reducing valves can also produce superheated steam. For example: 800 kPa steam at 170°C passing through a pressure reducing valve gives up no heat as it expands to 150 kPa, so the 150 kPa steam downstream will be at 170°C not 111°C. This is 59 kelvins of superheat and downstream valves and piping will be exposed to the higher temperature. To correct for superheated steam, 4 kJ/kg is added for each kelvin of superheat.

EXAMPLE:

300 kW of 150 kPa steam is required. From Table 6, 150 kPa steam has a latent heat of 2226 kJ/kg. If condensate leaves at 80°C, the steam gives up 2356 kJ/kg (2226 kJ/kg condensing the steam and 130 kJ/kg cooling the condensate from 111°C to 80°C). If the 150 kPa steam has 50 kelvins of superheat, the added heat is 200 kJ/kg. Thus, heat available from 150 kPa steam with 50 kelvins of superheat is:

$$2356 \text{ kJ/kg} + 200 \text{ kJ/kg} = 2256 \text{ kJ/kg.}$$

Steam quantity needed is:

$$\frac{300 \text{ kW}}{2256 \text{ kJ/kg}} = 0.117 \text{ kg/s} = 117 \text{ g/s}$$

STEAM DISTRIBUTION SYSTEMS

STEAM PIPING MAINS

Steam piping mains must carry steam to all parts of the system allowing a minimum amount of condensate (heat loss) to form, must provide adequate means to collect the condensate that does form, and must prevent water pockets that can cause water hammer.

Figure 102 shows typical connections at the boiler. The system shown uses a condensate (receiver) tank and pump. Condensate returns must be properly pitched for gravity condensate flow and properly insulated so heat contained in the condensate is not wasted.

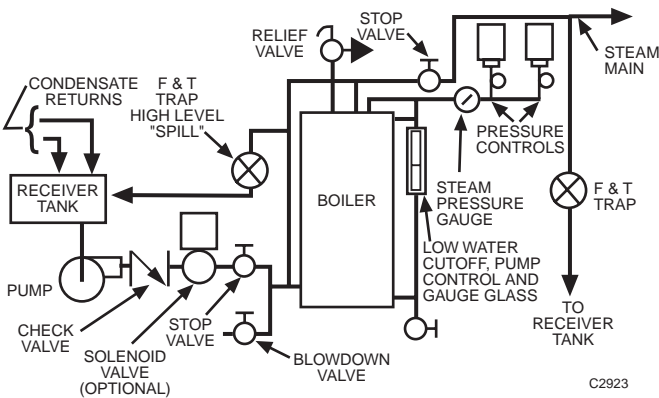
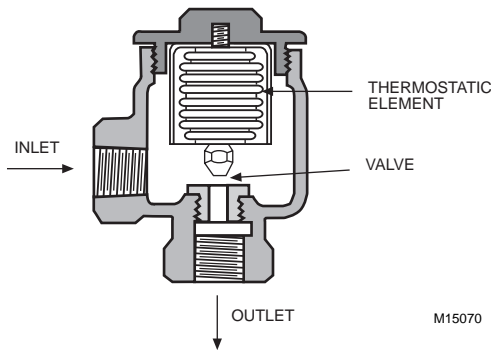

Fig. 102. Typical Boiler Connections.

STEAM TRAPS

Traps remove condensate from the steam mains and all steam-using equipment without allowing steam to enter the return mains. The thermostatic trap (Fig. 103) is most common for trapping condensate from radiators and convectors in low pressure systems. When the thermostatic element senses steam temperature, it closes the valve. The valve remains closed until the element cools.



Reprinted by permission from the ASHRAE Handbook—1996 Systems and Equipment

Fig. 103. Thermostatic Trap.

The float and thermostatic trap (Fig. 104) can handle large amounts of air and condensate and is commonly used on steam coils in air handling systems. In this trap, the thermostatic element passes air until it senses steam at which time it closes the valve. As condensate water builds up in the trap, the float valve opens to discharge condensate into the return line.

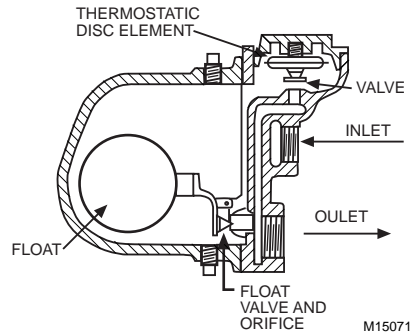

Reprinted by permission from the ASHRAE Handbook—1996 Systems and Equipment

Fig. 104. Float and Thermostatic Trap.

Another common trap is the inverted bucket (Fig. 105) which has a large capacity (up to 7 kg/s) for discharging condensate. In the bucket trap, the bucket is normally down so the valve is open. The bucket is normally about two-thirds full of condensate so, when condensate enters the trap, it flows around the bucket and through the trap. As air or steam enters the bucket, the bucket rises, closing the valve when the condensate level drops to about one-third full. Air escapes slowly through the air vent and steam condenses so the bucket drops, opening the outlet.

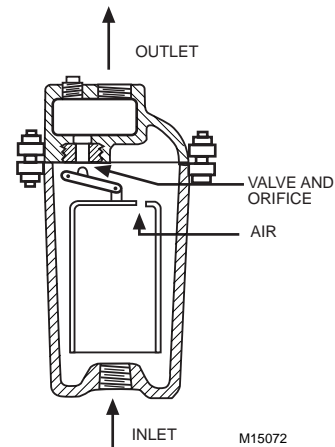

Reprinted by permission from the ASHRAE Handbook—1996 Systems and Equipment

Fig. 105. Inverted Bucket Trap.

Kinetic traps, shown in Figures 106, 107, and 108, are used in high pressure systems. They rely on flow characteristics of steam and condensate and on the fact that condensate discharging to a lower pressure contains more heat than necessary to maintain its liquid state.

The disc trap (Fig. 106) is a device with only one moving part. As steam in the chamber above the disc cools and condenses, the disc snaps open releasing condensate. These traps cycle independent of condensate load. Systems using these traps usually have a means of recovering heat from the condensate. They are used primarily on high pressure steam systems.

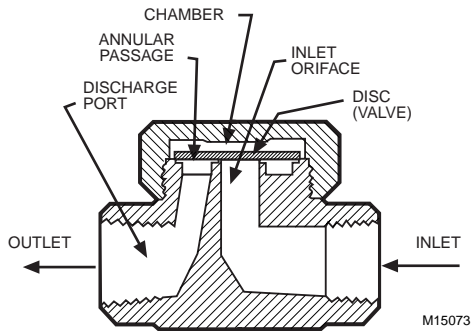

Reprinted by permission from the ASHRAE Handbook—
1996 Systems and Equipment

Fig. 106. Disc Trap.

The orifice trap (Fig. 107) has no moving parts. It relies on only a little steam flowing through the orifice because of the low density of steam compared to condensate. It must have constant supply pressure, constant demand, and constant ambient temperature to operate.

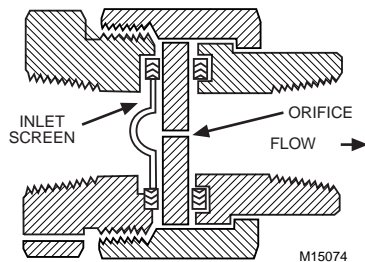

Reprinted by permission from the ASHRAE Handbook—
1996 Systems and Equipment

Fig. 107. Orifice Trap.

The piston trap (Fig. 108) relies on a pressure change caused by steam or condensate entering the trap to open or close the piston or port. A small amount of condensate bleeds through an orifice in the control disc into the control chamber. When steam or condensate that flashes to steam enters the chamber, the port is closed until the pressure in the control chamber falls. The port then opens allowing condensate to pass.

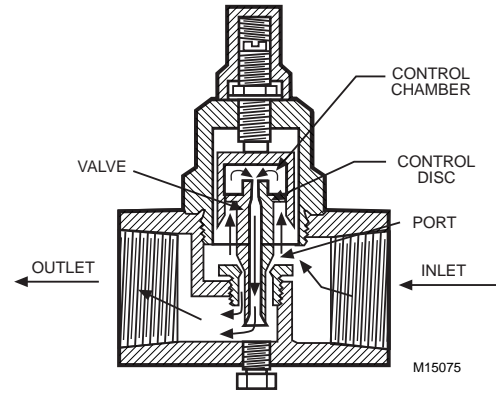

Reprinted by permission from the ASHRAE Handbook—
1996 Systems and Equipment

Fig. 108. Piston Trap.

PRESSURE REDUCING VALVE STATION

Pressure reducing valve (PRV) stations are used in steam systems where high pressure steam, usually at 500 kPa to 900 kPa, is distributed for low pressure requirements (Fig. 109).

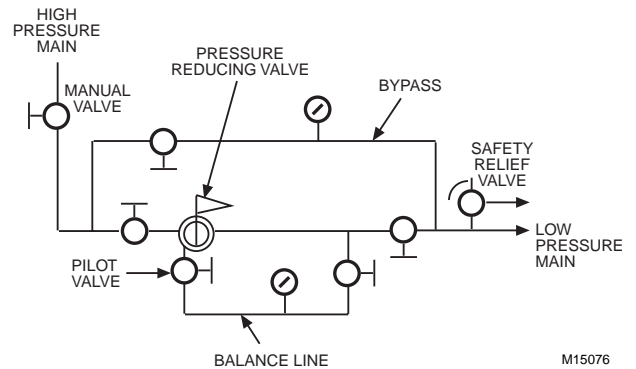

Fig. 109. PRV Station.

If steam is supplied at less than 500 kPa, a single stage PRV (Fig. 109) is required. For 500 kPa or higher main pressure, a second stage is added, in part because critical pressure drop (50 percent of the absolute inlet pressure) through a single stage PRV will cause noise and wear problems.

Since steam at 900 kPa has a temperature of more than 175°C and little heat energy is dissipated through a PRV, the 150 kPa steam leaving the PRV station will be superheated (temperature is more than 108°C) for some distance downstream from the station.

Selection of valve materials used to regulate the 150 kPa steam must take this superheat into account, particularly for a device in close proximity to the PRV.

TYPES OF LOW PRESSURE STEAM DISTRIBUTION SYSTEMS

One-Pipe Steam Systems

One-pipe systems were often used in small buildings and apartments because of their simplicity and low cost. The same pipe carried both steam and condensate (Fig. 110). They used gravity returns and, therefore, required no traps.

Control valves on individual radiators are a potential problem in one-pipe systems. As valves close, water is trapped in the radiators resulting in low boiler water and water hammer noise at the radiators when the valves reopen. Oversized valves controlled two-position are required to allow condensate to flow out of radiators while steam is entering. Thermostatic air vents allow steam to completely fill the radiator. Many one-pipe systems have no valves and temperature is controlled by cycling the boiler.

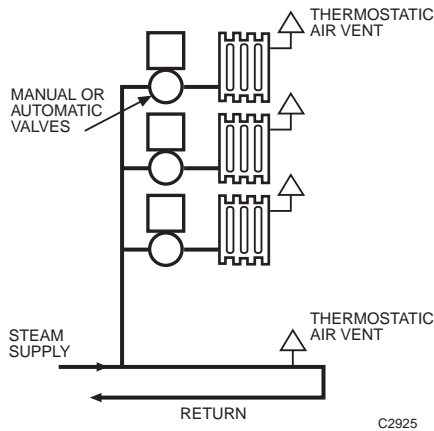

Fig. 110. One-Pipe System.

Two-Pipe Steam Systems

Two-pipe systems (Fig. 111) are used for all systems using automatic control of terminal units. A trap at each unit removes condensate.

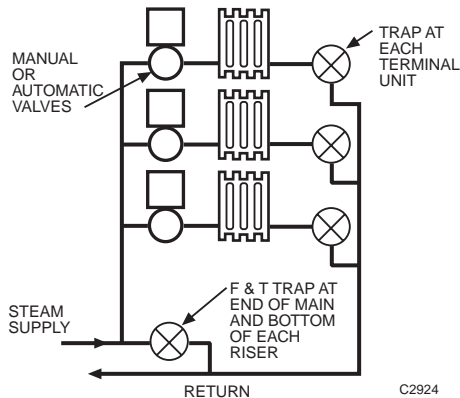

Fig. 111. Two-Pipe System.

TYPES OF CONDENSATE RETURN SYSTEMS

In addition to gravity return used for small systems, either open or vacuum return systems can be used.

In open return systems (Fig. 112) condensate flows by gravity to one or more receivers where it is pumped back to the boiler. Pumps are started and stopped by float controls in the receiver.

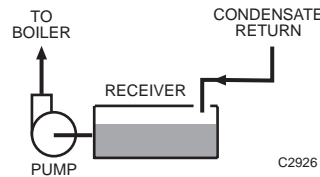

Fig. 112. Open Return System.

A vacuum return system requires a vacuum pump assembly to discharge noncondensable gases to the atmosphere and to force the condensate into the boiler (Fig. 113). A vacuum pump assembly consists of a vacuum pump, a separator tank, and an air vent.

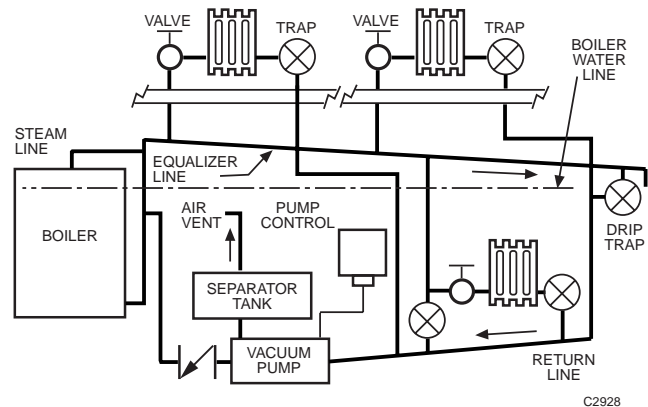

Fig. 113. Typical Two-Pipe Vacuum Pump System.

The vacuum in the return line draws a condensate/air mixture into the receiver. This mixture is forced into a separating tank where the air is vented to the atmosphere and the condensate returned to the boiler. The air is discharged through a check valve or a nonreturn vent to maintain a vacuum in the return line under operating conditions. The vent on the vacuum pump is usually the only vent in the system.

Typically, a selector switch allows the vacuum pump to be operated automatically or manually. In the automatic position a vacuum switch or float switch cycles the vacuum pump.

A steam system may be either open or closed. In a closed system all condensate is returned to the boiler. In an open system the condensate is expelled or used for other purposes, such as humidifiers, dishwashers, and autoclaves and must be replaced by makeup water.

Low pressure steam systems operate on pressures ranging from 100 kPa to 200 kPa. The steam main pressures are usually under 170 kPa and the returns are vented to the atmosphere. To maintain the return main pressures at 100 kPa, an air vent releases the air from the system when steam is present and allows it to return to the system when steam is not present. These vents do not allow steam to escape. A sealed chamber (bellows) within the vent contains a volatile liquid which vaporizes or condenses when temperature changes. This causes the valve to close when steam is present preventing the discharge of steam from the system.

Since all of the air in a steam system may not be forced out through the radiator vents, it is necessary to provide auxiliary vents at the ends of the steam mains and in the returns to ensure air removal from the system. These vents are larger than radiator vents and are referred to as quick vents.

VARIABLE VACUUM RETURN SYSTEMS

In a variable vacuum steam system, also called a sub-atmospheric steam system, the operating pressures range from 34 kPa (absolute) to 200 kPa. The principle of water boiling at reduced temperatures in a vacuum is the basis of a variable vacuum steam system. In an atmospheric-return low-pressure steam system, when the thermostat turns the burner off, boiling ceases as soon as the temperature of the water drops to 100°C. In a variable vacuum system, boiling continues until the water temperature drops to the boiling point of the vacuum pressure created by the condensation of steam in the system. This means that steam is continuously supplied to the radiator at a decreasing temperature until the limit of induced vacuum is reached. Table 7 shows reduced heat output from radiators in a vacuum system. To operate successfully, the system must be air tight. Variable vacuum systems use nonreturn vents which allow air to leave the system but none to return. A nonreturn vent is similar to the low pressure steam vent with a small check disc that closes to prevent inflow of air to the system when the pressure drops below atmospheric.

The period of time that a variable vacuum system can operate in the vacuum range is dependent upon the tightness of the connections of the system. Once a variable vacuum system has built up a vacuum, it is possible for the burner to operate at frequent enough intervals to keep the system within the vacuum range during mild and intermediate load conditions. Since a low steam temperature is maintained, the radiator temperature is low. By keeping the radiator warm for longer periods of time, temperature stratification in the space is reduced.

Table 7. Heat Output versus Steam Pressure for Coils.

Saturated Steam Pressure kPa	Steam Temp, °C	Typical Steam Coil ^a With 5°C Entering Air kJ/hr
200	120.2	119100
150	111.4	110400
101.3	100.0	101500
100	99.6	99800
90	96.7	97200
80	93.5	95100

^a 2 row steam distributing coil, 3 fins per centimeter, 2.5 meters per second face velocity, and 0.22 square meter face area

CONTROL PRINCIPLES FOR STEAM HEATING DEVICES

GENERAL

To control a steam supplied device, the system design should include valves and other equipment required to produce the amount of heat needed at design conditions. In addition, the system should be capable of controlling a steady flow of heat directly related to the demands of the thermostat or other controller at load conditions from 0 to 100 percent.

To design a steam system that is capable of controlling the various radiators and coils in a building, the pressure relationships between the various elements of a steam heating system must be analyzed under various load and system conditions.

MODULATING STEAM COIL PERFORMANCE

Figures 114 and 115 show a steam coil supplied from a 135 kPa steam main, controlled by an oversized modulating valve (Fig. 114) or a correctly sized modulating valve (Fig. 115), and discharging condensate to the return through a trap. The figures demonstrate the importance of proper sizing of the modulating valve and the ability of the valve to control the output of the coil. Refer to the Valve Selection and Sizing section for valve sizing procedures.

Oversized Valve

In Figure 114A a large valve is used to ensure 128 kPa in the coil. When the valve is full open, the coil is full of steam and the output is 30 kW. The return header and trap are also full of steam keeping the trap closed much of the time. The trap opens slightly when water accumulates around the thermostatic element allowing the condensate into the return mains. The pressure drop through the valve and coil is small, but large across the trap.

Figure 114B shows the pressure relationship and heat output as the modulating valve closes to the half-open position. The smaller opening in the valve requires 128 kPa to get the steam through the valve, called a 128 kPa drop across the valve. This leaves 107 kPa in the steam coil header. Although the thermostat has signaled to the valve to cut heat output in half, the coil is still full of steam and the heat output is only reduced by 5 percent. The reduction is because of the difference in temperature of 128 kPa steam compared to 107 kPa steam, assuming 10°C air temperature entering the coil. The trap drop is 5 kPa. Most of the pressure drop between the supply and the return mains is now across the steam valve. The portion of the modulating valve stroke between half open and full open reduces the heat output only 5 percent.

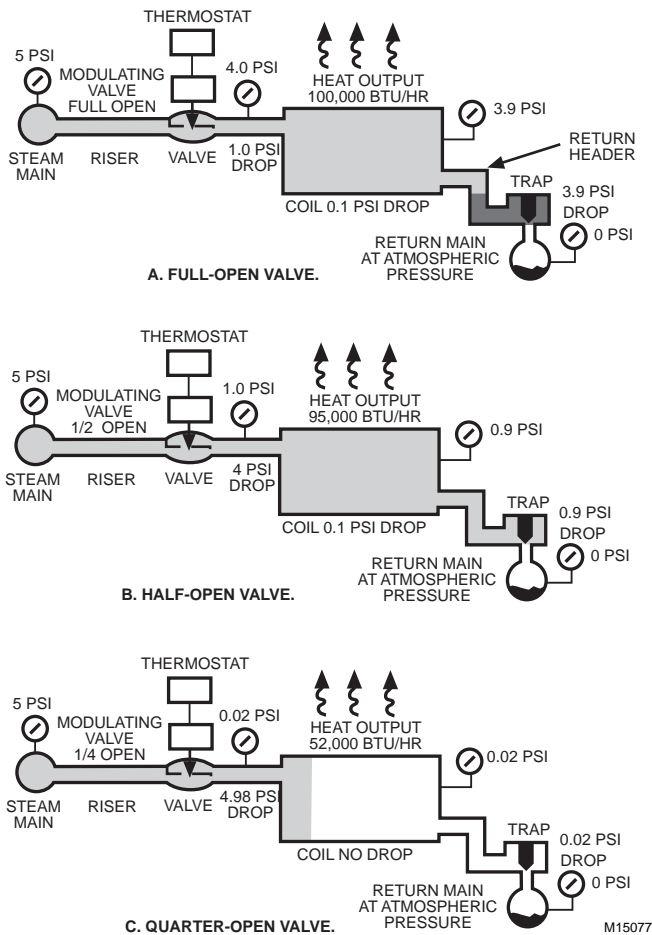

Fig. 114. Control Results with Oversized Valve.

Figure 114C shows the quarter-open valve position. Half of the coil surface is starved of steam, the heat output is reduced to about half of the original value and the trap is full open. All of the steam has been condensed in the coil before reaching the trap. Virtually all of the drop between the supply and return mains is dissipated through the control valve.

The conclusions reached from Figure 114 are:

1. The sum of the individual pressure drops across the valve, coil, and trap equals the pressure difference between the supply and return mains.
2. Heat output changes little due to pressure change within the coil, as long as the coil is full of steam.
3. Heat output changes little until the valve assumes most of the pressure drop between supply and return mains.
4. Heat output from the coil is reduced by starving a part of the coil surface of steam and allowing the surface to cool off.

NOTE: Steam distributing coils allow reduced output without the return end becoming cold.

Correctly Sized Valve

The valve in Figure 115A is sized for a 28 kPa pressure drop when it is full open leaving 6 kPa of steam for the coil and the trap. Full heat output of the coil is 28 kW and most of the drop between supply and return mains occurs across the valve.

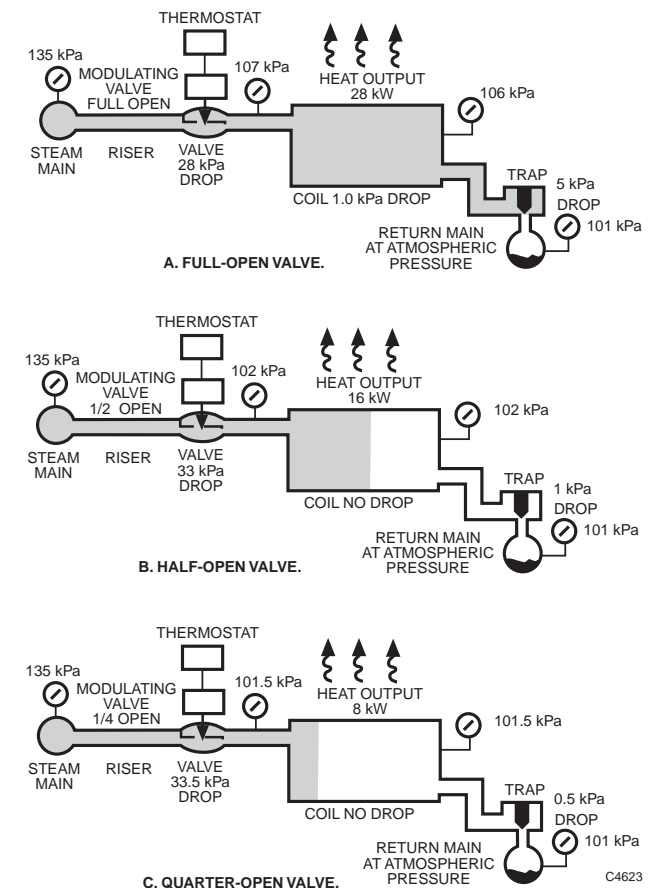

Fig. 115. Control Results with Correctly Sized Valve.

Figure 115B shows the valve in the half-open position. The output of the coil is cut approximately in half (16 kW). This is in contrast to the oversized valve application (Fig. 100B) where the heat was cut only 5 percent.

Figure 115C shows the output cut to 8 kW with the valve in the quarter-open position. In contrast, the oversized valve in the quarter-open position produced 15 kW.

The conclusions reached from Figure 115 are:

1. A valve with a large pressure drop will be effective in controlling heat output over its entire stroke.
2. The valve, not the trap, takes up most of the pressure drop between supply and return mains.

SUPPLY AND RETURN MAIN PRESSURES

The supply main pressure should be constant and sufficient to allow an 80 percent drop through the control valve and still leave enough steam pressure downstream from the valve to produce the desired heat output. If boiler pressure is not constant, install a pressure reducing valve ahead of all steam supplied devices where output temperatures may vary rapidly with steam pressure fluctuations.

Even though the control valves do not change position, variations in return main pressure causes fluctuations in steam flow through control valves. From a control standpoint, an atmospheric return with a condensate pump is more effective than a vacuum return with a vacuum pump that can cycle over a range of several inches of vacuum.

As an example of the effect of fluctuating supply and return main pressures, assume a system where the boiler cycles so that it shuts off at 145 kPa and cuts in at 115 kPa. On the same system assume that a vacuum pump is used which cuts in at 90 kPa and shuts off at 80 kPa. The pressure difference between supply and return mains can vary from a minimum of 25 kPa to a maximum of 65 kPa as the boiler and vacuum pump cycle. This means a 60 percent variation in capacity of the control valves in the building as the pressure fluctuates. Control valves correctly sized for 28 kPa are 60 percent too large during periods when a 65 kPa difference exists across the supply and return mains.

SYSTEM DESIGN CONSIDERATIONS FOR STEAM COILS

Figure 116 shows the optimum design conditions and piping arrangement for a steam supplied heating coil. Considerations for effective control are:

1. Steam mains held close to design pressures. Refer to SUPPLY AND RETURN MAIN PRESSURES.

2. Returns at atmospheric pressure, unless lifts (condensate pumps) are required in the returns.
3. Traps sized to pass design condensate flow at 7 kPa drop.
4. An equalizer line to prevent formation of a vacuum within coil.
5. A control valve pressure drop of 80 percent of the difference between supply and return main pressures.

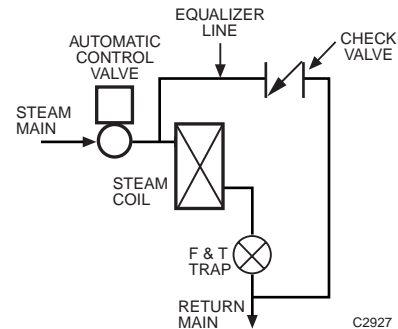

Fig. 116. Steam Supplied Air Heating Coil.

High vacuum systems are an exception to these considerations since they lower the steam temperature and pressure as the heating load decreases. Vacuum systems are adaptable to automatic control valves, since usual practice is to maintain a controlled difference between supply and return main pressures while varying supply main pressure with heating load.

LOW TEMPERATURE PROTECTION FOR STEAM COILS

Any steam coil exposed to outdoor air is in danger of freeze up in cold climates. A coil begins to freeze in the -1°C to 0°C temperature range. Steam coils designed for heating cold air contain internal distributing tubes to ensure that steam reaches all parts of the coil as the control valve modulates.

Another approach to freeze-up control is to design coils with dampers so that the control valve does not modulate but remains open when air entering the coil is below freezing. If too much heat is being delivered, face and bypass dampers control the airflow across the coil. Above freezing, the valve can be modulated.

In all cases, a low limit temperature controller, which responds to the coldest portion of the capillary sensing element, should be part of the design. For addition examples of control with freezing air conditions entering a coil see Air Handling Systems Control Applications section.

HIGH TEMPERATURE WATER HEATING SYSTEM CONTROL

INTRODUCTION

HIGH TEMPERATURE WATER (HTW) HEATING

High temperature water systems operate with supply water temperatures of 120 to 230°C and pressures from 500 to 3000 kPa.

HTW is typically generated by boilers; however, experimental systems utilizing geothermal or solar energy have been built. First costs are similar for steam and high temperature water systems, however, maintenance and operating costs are generally lower for HTW systems. The use of the same boiler for both HTW and steam generation is not recommended because feed water requirements for steam eliminate some of the advantages of HTW.

When relatively small amounts of steam are required, steam can be produced from HTW at the required location. A steam generator using 175°C HTW (900 kPa) will produce 200 kPa steam and using 190 to 210°C HTW (1300 to 1900 kPa) will produce 800 kPa steam allowing a HTW temperature drop of 30 to 35 kelvins.

A HTW system offers several advantages over a steam system:

- Boiler sizes can be smaller than low pressure boilers because of the high heat capacity in a HTW system.
- Diameter of distribution piping can be reduced.
- The piping system requires no grading for return of water to boiler.

- Feedwater requirements are minimal, eliminating treatment costs and introduction of air which is a source of corrosion. HTW systems tend to remain clean.
- Steam traps and condensate receivers, sources of heat loss and maintenance costs are eliminated.
- Heat not used in terminal heat transfer units is returned to the HTW generator.

Several major design characteristics are typical of HTW systems:

1. The HTW boiler is controlled by pressure rather than temperature to eliminate flashing if heating load fluctuates.
2. Multiple boiler systems must be designed so that loads are divided between the boilers. Generally it is less costly to operate two boilers at part load than one at full load.
3. HTW systems can be pressurized by steam or air in the expansion tank but typically an inert gas such as nitrogen is used because it absorbs no heat energy and excludes oxygen.
4. All piping is welded except at mechanical equipment which must be maintained. Connections at equipment are flanged, including provision for removal of small threaded control valves.
5. Terminal units are rated for the high temperature and pressure.

Figure 117 illustrates the elements of a typical HTW system.

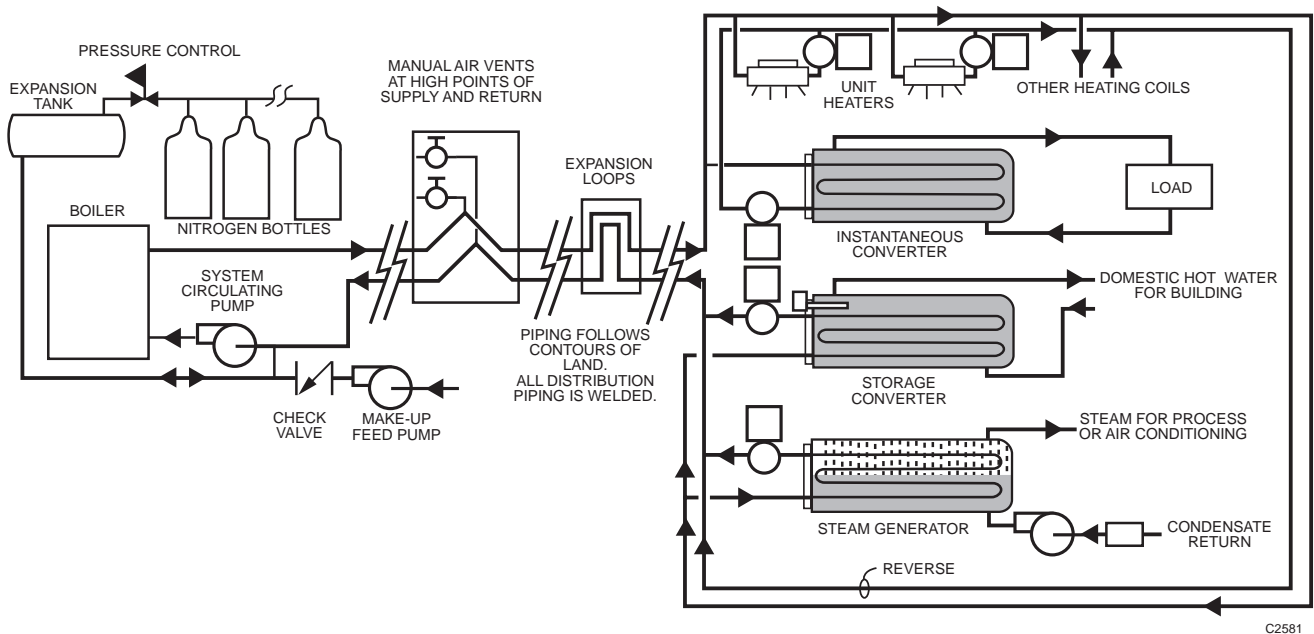

Fig. 117 Typical Nitrogen Pressurized High Temperature Water System.

HIGH TEMPERATURE WATER SAFETY

A well designed HTW system with proper installation of piping to prevent undue stress rarely fails.

HTW drops in temperature very rapidly with a minor, low mass, flow leak into space. In low or medium temperature water the escaping fluid remains at nearly the same temperature. HTW flashes to steam and the turbulent mixing of liquid and vapor with the room air rapidly drops the fluid temperature below 100°C and within a short distance to 52 to 60°C.

Minor leakage at valves is usually imperceptible except for deposits of scale at the point of leakage. Valves should be inspected periodically and scale removed from valve stems to prevent damage to packing and to allow free valve movement.

HTW CONTROL SELECTION

The features of good temperature control for low and medium temperature water heating systems also apply to high temperature water heating. Special considerations are needed for controls to withstand the temperatures and pressures encountered in a HTW system. The large temperature difference between HTW and the heated fluid (air, water, or steam) means that most of the control selection precautions are to provide fail safe operation. Careful consideration must be given to what happens to the secondary fluid of a converter and its controls when flow is reduced or stopped, or equipment is shutdown. Secondary fluid can overheat immediately after or during prolonged shutdown. Controls near a HTW supplied coil can be damaged by high temperature if airflow stops.

Controls can be pneumatic, electric, or digital. The low mass of electronic temperature sensors (thermocouple or resistance bulb) provides faster response than fluid-filled or bimetal elements. Pneumatic actuators generally have the faster response, higher temperature ratings, and greater reliability required for HTW applications.

Standard commercial quality controls with integral (automatic reset) and derivative (rate) action are satisfactory for most applications when used with industrial quality valves. An industrial controller or a digital system may be required where local recording of a control value is specified. The control system selected should:

1. Function from zero to full load.
2. Close the HTW valve if there is failure in the control system, loss of power or air, or shutdown of the system being controlled.

HTW VALVE SELECTION

Valves for HTW must be selected to ensure suitability for high temperature and pressure conditions. A control valve must have wide rangeability (50 to 1 is desirable) and the ability to position accurately and hold that position. Rangeability is the ratio of maximum flow for a valve to the minimum controllable flow. These requirements dictate use of industrial quality valves. For additional information on rangeability see the Valve Selection and Sizing section.

VALVE STYLE

Single seated valves are recommended because of their tight shut-off and availability with equal percentage and reduced capacity (Kv) trim.

Double seated valves are not recommended because they do not provide tight shut off. High velocity leakage past the plug of a double-seated valve causes greater erosion to the seats than a single-seated valve.

Three-way valves are not recommended because they are not available with equal percentage flow characteristics and therefore do not provide the required control stability. They also are not available with reduced Kv trim for accurate sizing.

Valve bodies should be flanged although threaded bodies can be used for sizes of ISO 32 mm or less. Weeping and flashing at threads is likely but usually not visible except for deposits left behind. If threaded valves are used in the HTW lines, use adjacent bolted flanges not union fittings.

VALVE BODY MATERIALS

Cast steel bodies with 2000 kPa or 4000 kPa body ratings are recommended. These have temperature ratings above 400°C, the limit for packing materials. Manufacturers literature lists actual pressure and temperature ratings.

Bronze bodies are not recommended because the maximum temperature limit is 200°C. In addition, since HTW piping is steel, galvanic action between bronze and steel can be serious at the elevated temperatures encountered.

Cast iron bodies are not recommended because maximum operating conditions are limited to 208°C at 1700 kPa, which are too close to operating conditions.

VALVE TRIM

Use stainless steel valve stems and trim. Standard trim for industrial valves is usually 316 stainless steel. Composition discs leak and corrode at the seat and disc and are not used.

VALVE PACKING

Shredded Teflon, Teflon asbestos, graphite asbestos, and spring loaded Teflon V-rings, are available in industrial valves and acceptable to 230°C. A valve with a deep packing gland is normally required.

VALVE FLOW CHARACTERISTICS

The flow characteristics of a valve is the relationship between fluid flow expressed in percent of flow and valve stem travel expressed in percent of travel. Always use equal percentage characteristic valves for HTW control. Equal percentage valves compensate for the nonlinear heat output of HW heat exchangers so percent of heat output change is equal to percent of valve travel. These valves provide the best control at low flows. An industrial valve with an equal percentage plug has the required rangeability of 50 to 1.

ACTUATORS

Valve actuators must close the valve on loss of power or control air.

If the close-off rating is less than twice the expected pressure difference across the closed valve, positioners on pneumatic valves are used only, otherwise, sequencing of multiple valves is required. Electro-pneumatic positioners or separate electro-pneumatic transducers can be used to receive an electric signal (4 to 20 mA) and operate the pneumatic valve.

Electric actuators are not satisfactory for HTW valves because they are not available with a safe ambient temperature rating and the operating speed is too slow.

VALVE SIZE

Accurate valve sizing is critical for satisfactory HTW control since an oversized valve controls over only a small fraction of its total stem travel and loses sensitivity. Safety factors should be avoided but if used should be very small. See the Valve Selection and Sizing section.

The pressure drop across a control valve should be between 50 and 80 percent of the drop across that part of the piping system in which flow will vary as a result of valve action. Always use a 35 kPa or greater pressure drop across the valve.

VALVE LOCATION

Always locate a HTW valve on the return side of the converter, coil, steam generator, or other equipment because it allows the valve to operate at lower pressures and temperatures. HTW is less likely to flash when the valve is located on the return side of the equipment.

INSTANTANEOUS CONVERTER CONTROL

An instantaneous converter is the standard type of converter used in nearly all HTW heating installations because of its extremely fast response. It is compact and available as standard equipment.

The HTW flows through several passes of tubing within a shell just large enough to accommodate the tube bundle. Secondary water is supplied into the shell and surrounds the tubes (Fig. 118). Only a small amount of HTW is needed to heat a large volume of secondary water and the change is nearly instantaneous. There is no room within the shell for a temperature sensing element to quickly detect the change, therefore, the temperature sensor must be located as close to the converter as possible.

There must be a provision in the control loop to close the HTW valve as soon as the secondary flow ceases. This requires proving flow in case the flow stops for a reason other than the pump is stopped by outdoor temperature, another signal, or power failure. Even if the HTW valve closes as soon as secondary water flow stops, flashing is likely to occur as there is enough HTW in the tubes to overheat secondary water. Flashing causes water hammer and possible equipment damage. If shutdown is controlled, closing the HTW valve immediately and delaying the secondary pump shutdown allows excess heat in the converter to dissipate.

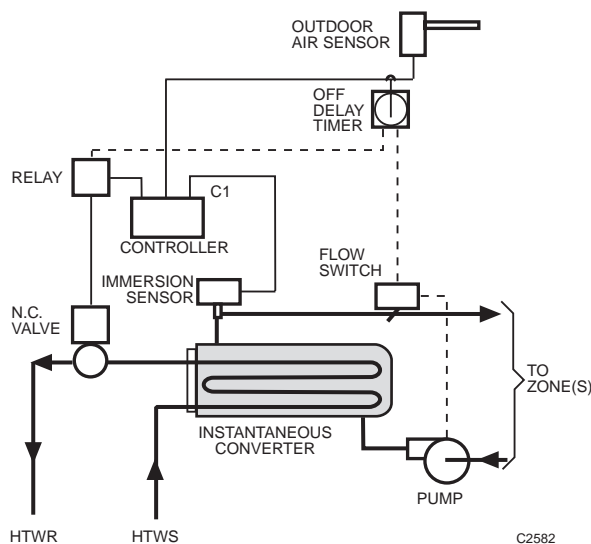

Fig. 118. Control of HTW to Constant Temperature Hot Water Converter.

A constant temperature hot water supply is used where a minimum temperature is required for all or part of the converter load. Normally a converter for space heating does not require fast response as the load changes only as fast as occupancy and outdoor air conditions change. Because of the inherent fast converter response there are several control requirements:

1. The primary sensing element must be located in outlet water as close to the converter as possible.
2. A stainless steel well that matches the element with heat conductive compound in the well must be used.
3. A primary control must be used that has integral action and integral cutout to allow a wider throttling range for stability with minimum deviation from setpoint and to eliminate integral windup.

A control arrangement for a typical zone supplied with HW from a HTW to constant temperature HW converter is shown in Figure 119. Water temperature in the converter shell must be reset from the outdoor air temperature for best control. Zones typically are also reset from outdoor temperature.

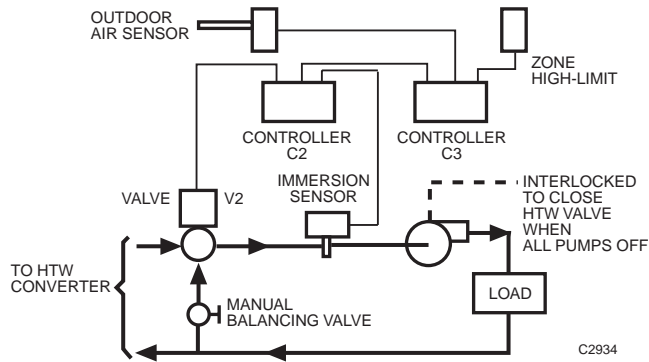

Fig. 119. Typical Zone Control of Constant Temperature HW from HTW Instantaneous Converter.

For modulating control, instantaneous converters must operate with at least half design flow. To accomplish this, reset schedules of controller C1 (Fig. 118) and C2 are arranged so that valve V2 will be between half and full open to the converter under normal conditions of operation. The reset schedule for the converter is slightly higher than the temperature normally required in the zones so that most of the water to supply the needs of the zones must come from the converter rather than the bypass.

C2 as the primary control prevents C3 from positioning V2 so the return water bypasses the converter. If flow is cut off through the converter, the sensor located in the outlet piping rather than within the shell cannot control V1 in a stable manner.

The use of an instantaneous converter (Fig. 120) for heating water supplied directly to an air heating coil provides fast response. Control system selection problems are the same as for the control of a coil supplied with low or medium temperature water except that a high quality valve with fast control response is required for HTW.

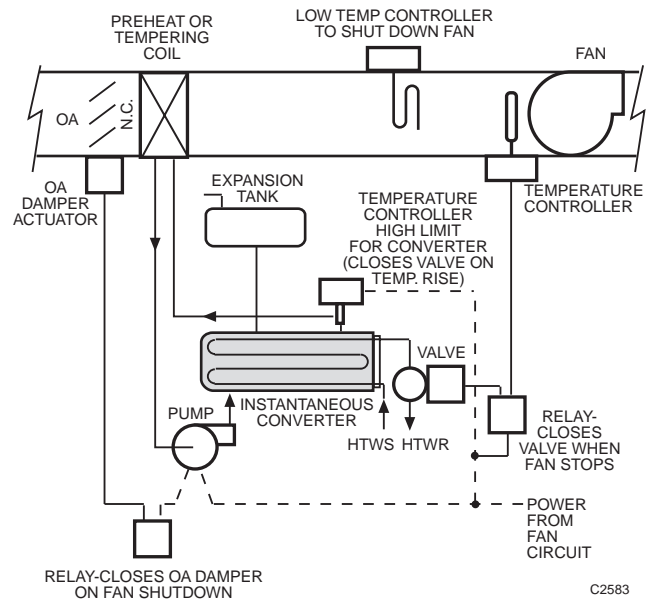

Fig. 120. Instantaneous Converter Control for HTW to Glycol Solution for Outdoor Air Preheat.

Where coils are exposed to freezing temperatures, as in a 100 percent outdoor air supply unit, the cost of installing a foolproof control system plus necessary duct work and dampers make the use of a water supplied coil questionable. Flow to the coil should be constant with variable temperature. Better protection against freezing is obtained by use of a heat transfer fluid such as a glycol solution.

Glycol solutions used with HTW heating must be closely monitored. Solutions of ethylene or propylene glycol assume the corrosivity of the water from which they are prepared and are oxidized by air into acidic products. The deterioration rate of inhibitors and stabilizers added to commercial glycol is influenced by temperature, amount of air in the solution, and, to some extent, the metals in the piping system. Heat exchanger surfaces should be kept below 140°C as temperatures above 148°C accelerate deterioration of inhibitors.

If HTW flow is stopped while the air handling unit continues to operate with below freezing entering air temperature, heat transfer solution returning to the converter could cause the converter to freeze. A low-limit duct temperature controller is recommended to stop the fan if a low air temperature leaving the coil is sensed.

HTW COILS

Figure 121 shows an acceptable method of mixed air control when there is a possibility of freezing air passing through the heating coil. Face and bypass dampers control the heat output of the coil during normal operation. When the outdoor temperature rises so that no heat is needed from the coil, valve V1 closes preventing overheating from the down stream side of the coil. The low-temperature limit controller senses the air temperature leaving the coil and opens the valve on sensing a freezing temperature. Use of a glycol solution as shown in Figure 120 is recommended.

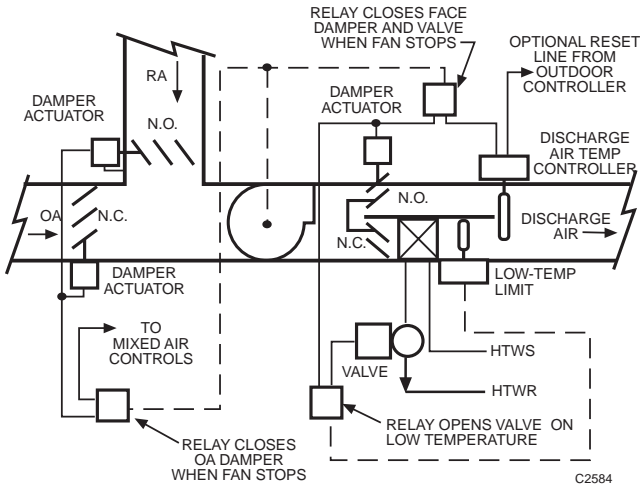

Fig. 121. HTW for Mixed Air Reheat.

HTW SPACE HEATING UNITS

Unit heaters, convectors, radiation, and radiant panels can be supplied directly with HTW. This allows use of smaller units and smaller piping and eliminates intermediate heat exchangers. Most of the additional control cost is in the valves suitable for HTW as the small unitary control valves normally used on low and medium temperature heating systems are not able to stand the pressures and temperatures of HTW. Actuator design, body ratings, disc materials, packing gland design, and lack of low flow ports are all likely limitations for this type of valve. Flanged connections are required as union connections do not seal well enough for HTW applications.

These units are most often used in storage areas, shops, hangers, or other areas where people do not work in close proximity to the units. Where people do work near HTW supplied unitary equipment, some type of limiting control is required to reduce surface and/or discharge temperatures.

STORAGE CONVERTERS

A storage converter is most often used for heating domestic water (Fig. 122). It can also be used for building heating. Separate converters are required for domestic water and building heating (Fig. 123). Heating system water is treated and recirculated while domestic water is used and replenished.

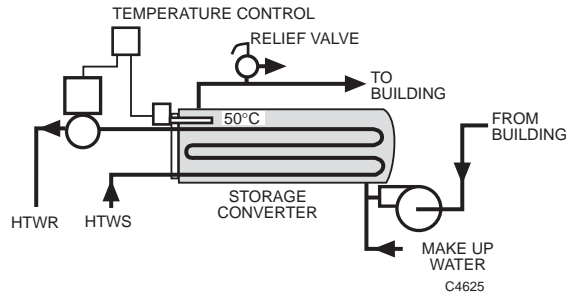

Fig. 122. Direct HTW to Domestic Hot Water.

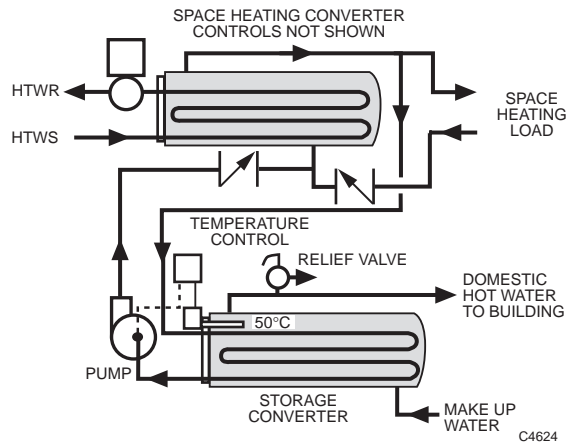

Fig. 123. Indirect HTW to Domestic Hot Water.

In a storage converter, the tube bundle is immersed in the bottom of a storage tank (shell) with capacity to provide for large intermittent demands. There is little lag in transferring heat from the tube bundle but because of the large capacity of secondary water in the shell, the system provides more stable control. Rate of change might be 11°C to 28°C per hour. Large installations frequently employ a system circulating pump to assure quick availability of hot water at remote usage points and help eliminate stratification in the tank.

MULTIZONE SPACE-HEATING HTW WATER CONVERTERS

Figure 124 shows a storage converter application. It is controlled as a conventional converter with only the HTW valve and pump interlock having special requirements because of the heating medium.

Because the response rate of a storage converter is slow, the storage capacity must be sufficient to supply any sudden demands. Warm-up is the demand period where the converter recovery rate becomes the determining factor for length of time required for warm-up. Normally all other changes in a building heating system are gradual.

HTW STEAM GENERATORS

Using the central HTW boilers for steam production is not recommended. The HTW system is best used to produce steam by locating steam generators at the point of need.

The steam generator (Fig. 125) is designed so that the minimum water level covering the tubes takes up 60 percent or less of the volume of the shell. The remaining 40 percent for steam is sufficient to avoid water carry over. A water eliminator at the steam exit removes most water from the steam.

Flash converters convert HTW to steam by reducing the pressure. They are not satisfactory steam generators because water is carried with the steam and control is less stable.

Control of a steam generator is simpler because pressure changes are sensed immediately and corrections in valve position are made quickly to maintain the desired steam pressure.

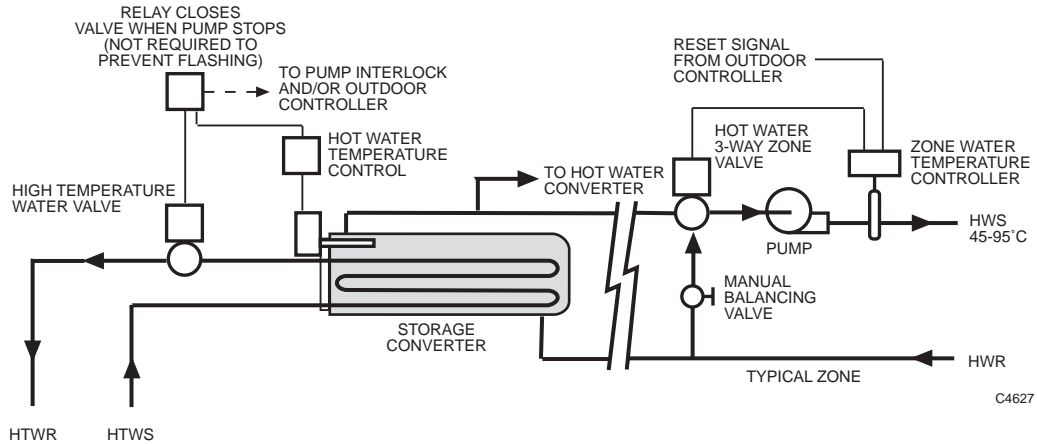

Fig. 124. HTW to HW Multizone Storage Converter.

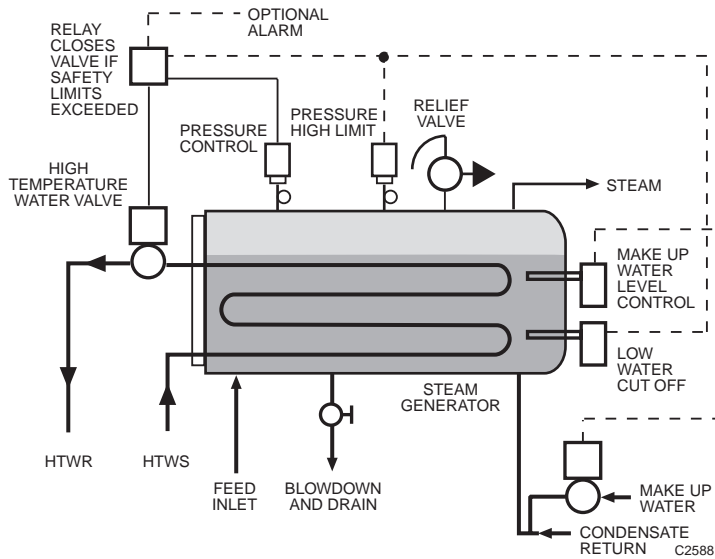

Fig. 125. Steam Generator Using HTW.

DISTRICT HEATING APPLICATIONS

INTRODUCTION

District Heating (DH), refers to a method of supplying heat to buildings, factories, and other facilities from a central source. The basic structure of District Heating Systems is shown in Figure 126. A DH System consists of one or more heat generating facilities, a widely spread heat distribution network, and substations between the distribution network and the consumer. Heat is generated by the heat source(s) and transferred to an appropriate heating medium such as hot water or steam. The heating medium is transported via pipelines to a substation. In the substation heat is transferred to the individual heating systems of the end-users.

Space heating, space cooling, and domestic hot water supply represents the largest part of energy consumption (75%) in buildings and industries. This demand is met mainly by fossil fuels and electrical energy. At the same time a vast amount of waste heat is discharged into the atmosphere by power and waste incineration plants and other industrial processes. The efficiency of current power plants does not exceed 50%.

District heating brings the waste heat directly to the customers as a salable product. This makes individual furnaces redundant. Additional advantages result from higher efficiency of central heat generation, lower emissions, and the capability of fuel diversification by using the fuel with the lowest price and the best availability. A central energy supply, based on combined heat and power generation has an overall efficiency of up to 80%. Additionally it shows a considerable emissions reduction from reduced fuel consumption.

HEAT SOURCES

Sources of heat to supply the network include waste incineration plants, boiler houses, heat pumps, and waste heat from electric power generating plants, steel foundries, or similar industrial processes.

A combined heat and power plant (CHP) which generates electricity using a steam turbine or an engine is probably the most common heat source. It heats the heating medium in the distribution network using the exhaust gases leaving the turbine.

Because these systems are parts of an industrial processes, control components and systems are typically industrial standard. Control components and systems are chosen to meet the requirements of the heat source and the specifications.

THE DISTRIBUTION NETWORK

Pipelines transfer heat from where it is generated to the consumer. Depending on the heat source, the distribution network generally consists of pairs of supply and return pipes. Hot water flows continuously through the supply pipes to the substations, heats the secondary fluid in heat exchangers, and returns to the heat source through the return flow pipes.

The distribution network facilities also include booster pumps and pressure reducing stations, mixing (temperature reducing) stations, key-points with valves to turn on or shut off branch lines and a large number of measuring points distributed over the entire network.

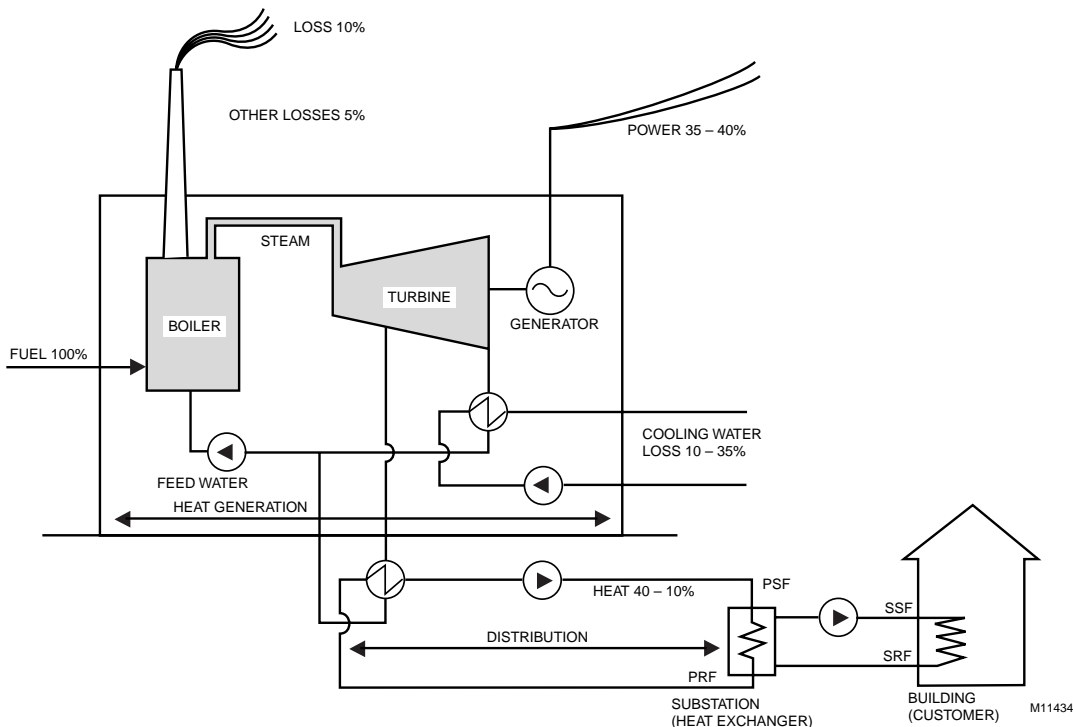

Fig. 126. District Heating Network.

The transfer medium is generally hot water at temperatures up to 200°C and pressures up to 20 bars (2000 kPa). The optimum operating conditions, temperature and pressure, depend on the structure and dimensions of the network and the heat source. The water temperature is generally limited to 130°C on the supply side. In fact, many networks now keep the supply temperature under 80°C allowing use of lower cost equipment and fewer safety devices. See HOT WATER DISTRIBUTION SYSTEMS and HIGH TEMPERATURE WATER HEATING SYSTEM CONTROL.

Outdoor Air Temperature Control reduces the supply temperature in a network with increasing outdoor temperature. The Return Water Temperature in a DH Network is controlled to not exceed either a fixed or variable temperature level.

THE SUBSTATION

Substations house heat exchangers which transfer the required heat from the distribution network to individual building heating networks (customer). In some cases, a large heat exchanger station (HES) is required between different types of networks. The HES transfers heat from high power primary networks to smaller secondary networks with lower temperatures and pressures.

A DH system only works efficiently if all components are matched to one another. The heat source must deliver the required heat at the lowest cost level, 365 days a year. Heat demand as a function of the day of the week, time of day, and weather conditions must be predicted in order to manage the heat supply in the most efficient manor. In combined heat and power (CHP) plants the electrical power generation must also be considered.

Managing a system requires highly sophisticated dedicated software and highly reliable control equipment. The software, which includes demand prediction and total energy management functions, plays an important role in the efficiency of CHP systems.

ABBREVIATIONS

CHP	—	Combined Heat & Power.
DH	—	District Heating.
DHW	—	Domestic Hot Water.
ESD	—	Emergency Shut Down systems

HES	—	Heat Exchanger Substation.
HEX	—	Heat Exchanger.
HTS	—	Heat Transfer Station.
OAT	—	Outdoor Air Temperature.
PRF	—	Primary Network Return Flow.
PSF	—	Primary Network Supply Flow.
RT	—	Return Water Temperature.
SRF	—	Secondary Network Return Flow.
SSF	—	Secondary Network Supply Flow.

DEFINITIONS

Booster Pump station: Maintains sections of a network (return or supply pipe) in required pressure conditions. Used in long networks or highly elevated sections.

Combined Heat & Power: Combines production of electricity and heat for space (buildings) and processes (industrial)

Domestic Hot Water: Water controlled at a constant temperature suitable for use in showers and hand washing stations.

Differential Pressure Controller: Prevents too low or too high hydraulic pressure at the building heat exchanger substation. This improves the control performance of the station.

Heat Exchanger Substation: Compact Station, controls the radiator and DHW loop in a building.

Heat Exchanger: Also called a convertor, transfers heat from the primary network to a secondary network.

Heat Surface Factor: A value corresponding to the effectiveness of radiating surface. The value depends upon the shape, size, and color.

Heat Transfer Station: Controls flow, pressure and temperature in sections of a primary network.

Primary Network: Supply and return pipe for heating medium (hot water or steam) from the heat/power plant to the consumer heat exchanger.

Secondary Network: Supply and return pipe for heating medium (actuator) from heat exchanger to radiators or tabs.

SYMBOLS

Since District Heating is more common in Europe, District Heating is based on information supplied by personnel in Europe. The symbols used in Figures 126 through 143 are those commonly used in Europe and are supplied here for convenience.

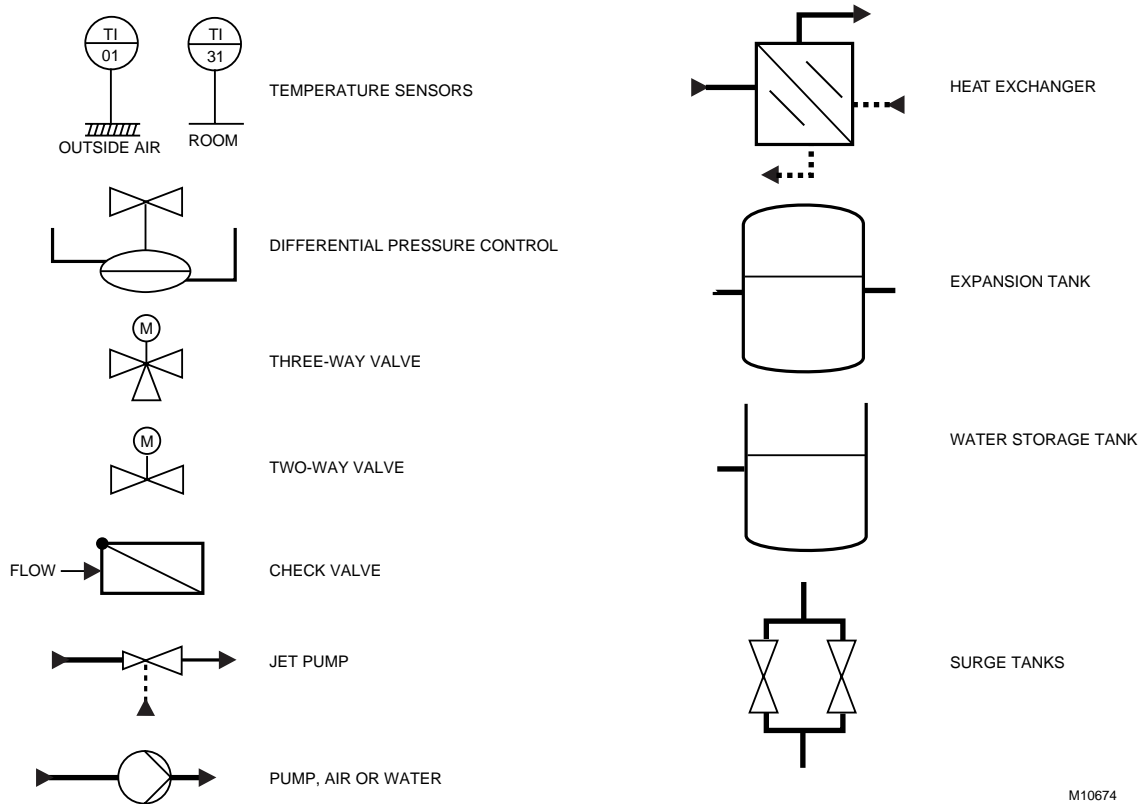

M10674

SYSTEM CONFIGURATION

HEAT GENERATION

Excess heat is produced in steam electrical power generating stations which can be reclaimed as in Figure 126 and sold to provide heat for other uses. Other industrial processes and waste incineration may also provide a source of excess heat which can be reclaimed. Geothermal sources and boilers are other heat sources.

HEAT DISTRIBUTION NETWORK

The distribution network is one part of a district heating system. It transports the heat from the heat source to the consumer. Heat is absorbed by the heat transfer medium, hot water or steam, at the source and delivered to the consumer.

Primary networks are one- or two-pipe distribution systems. In a two-pipe system the hot pipe, or supply line, transports the water or steam to the substation, heat is drawn from the network at the substation and transferred to the consumer's side, then

the cooled water or condensate flows through the return line back to the heat source to be re-heated.

A one-pipe system transports the water to the consumer, heat is drawn from the network at the substation and transferred to the consumer's side, then the cooled water is discharged to a drain. This system is used with a geothermal hot water source.

HOT WATER SYSTEM CONTROL

Variable speed circulating pumps move the water through the primary network providing the needed differential pressure in hot water systems. An additional pressure holding system is installed to keep the absolute pressure at the required level.

There are two control strategies based on outdoor air temperature for transferring a requested amount of heat to the consumer:

1. Constant Flow Control maintains a constant supply flow rate and varies supply flow temperature.
2. Variable Flow Control maintains a constant supply flow temperatures and varies supply flow rate.

The optimal temperature/pressure ratio depends on the length and structure of the network, actual load, outdoor air temperature, and pipe insulation. Because of the many variables, a combination of both Outdoor Air Temperature Control and Variable Flow Control or Variable Temperature Control is often used.

STEAM SYSTEM VS HOT WATER SYSTEM

Steam networks differ mainly in the following points from hot water systems:

- No pumps are required, the pressure difference between boiler and consumer drives the movement of the steam.
- Condensate traps are required approximately every 500 meters.
- The return line diameter is much smaller because condensate takes up less space than steam.
- Heat losses are significantly higher than hot water systems.
- The heat storage capacity of steam is lower than hot water.
- Maintenance costs are higher than hot water.

HOT WATER PIPELINE SYSTEM

Hot water systems must be protected against high pressure peaks which could damage the pumps and pressure drops below the evaporation point which results in the water changing to steam. Common types of preinsulated pipelines must be protected against temperatures exceeding 130°C.

Factors affecting efficiency include optimal temperature/pressure ratio with respect to the length and capacity of the network, temperature differences between supply and return flow, heat and water losses, as well as friction between the water and pipe wall. Higher temperatures cause greater heat loss by radiation and conduction while greater differential pressure in the network produces heavier pump loads. Every network has a different optimum value for the supply and return pipelines. Use of friction reducing chemicals to decrease the friction losses in the pipeline can reduce the pump power required. Extracting as much heat at the substations as possible also reduces pumping costs.

Additionally the water in the entire district heating system pipelines also serves as a large heat accumulator and helps compensate for peak loads or short periods of low heat generation.

BOOSTER PUMP STATION

In large pipeline systems, using a single main pump requires a large differential pressure to overcome the friction in the network. Figure 127 shows a profile of a single pump system. Decentralized pumps (booster pump stations) avoid this and keep the pressure in every pipeline section within the required levels.

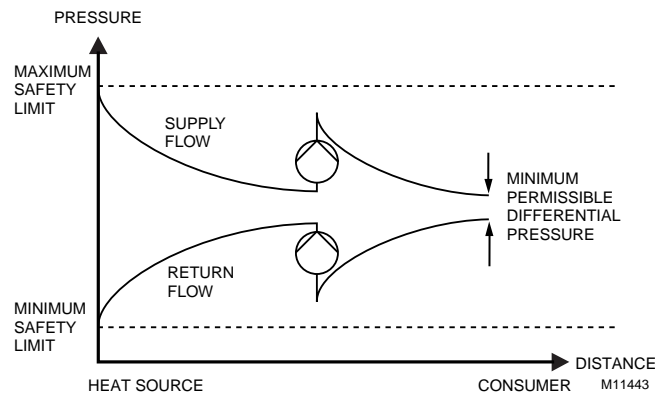

Fig. 127. Network Pressure Profile.

A booster pump station overcomes the pressure drop in areas with considerable differences in altitude (to overcome 50m difference in altitude a pressure of 5 bar (500 kPa) is required). They are often applied where going under or over obstacles is necessary. Equip the pipeline with an emergency shut down system (ESD) in areas with considerable differences in altitude to protect the system from high pressures in case of power failure.

PRESSURE REDUCING STATIONS

A pressure reducing station is the counterpart to the booster pump station. A pressure reducing station is used in lines located in mountainous areas to protect the pipeline from over pressure and to keep the pressure in the return line lower than the supply line. For this application pressure reducing valves are control valves.

MIXING STATION

A mixing station (Fig. 128) is used in hot water networks. It is a variable speed (mixing) pump which mixes cooled return flow directly into the supply flow line to reduce the supply flow line temperature to the required level. These facilities are used to provide different maximum temperatures in the network pipeline.

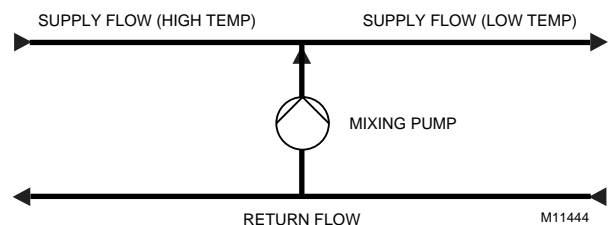

Fig. 128. Principle Of A Mixing Station.

KEY POINTS

Key points are locations where pipelines branch off (Fig. 129). They consist of valves for supply and return flow which can separate the branch line from the main line. If a branch line is shut down, the pressure ratio in the entire network is affected. To prevent pressure spikes in the main system, the shutdown must be performed slowly and carefully. Often two different sized surge tanks in parallel are used to damp the pressure peak during shutdown. Usually key point temperatures and pressures are monitored.

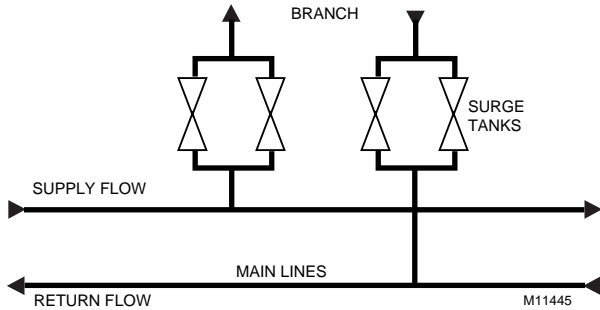

Fig. 129. Typical Key Point.

HEAT TRANSFER SUBSTATIONS

In general heat transfer substations link district heating networks with the consumer. The consumer side can be either another network or the end user.

Heat transfer can be either direct and indirect. Direct transfer uses mixing valves, jet pumps or two way valves to supply the heating medium directly to the consumer. Indirect substations use heat exchangers and physically decoupled or independent heating circuits.

Direct Heat Transfer Substations

The main parts of a direct substation are:

- Primary side.
- Heat flow regulation unit.
- Circulating pumps.
- Secondary side.

Direct heat transfer substations:

- Transfer the required heat from the supply (primary) side to the consumer (secondary) side.
- Meter heat.
- Provide safety functions to protect consumer and equipment against overheating, frost, and harmful agents in hot tap water.
- Provide optimization functions to reduce energy consumption to the lowest possible level.

Functional principles:

The primary side consists of the supply and return lines, plus necessary pressure reducing, regulating, and safety equipment.

This is self-regulating equipment which provides a given differential pressure, absolute pressure reducing, and safety close off functions.

The heat regulation unit (Fig. 130) provides the required temperature by controlling the primary flow (A) or by mixing the cooled return water with supply water (B). Different configurations with two and three way valves can be used. In the flow control configuration a fixed speed circulating pump increases the pressure in the return line above the supply flow pressure. In the temperature control configuration either a jet pump or a three way valve is used.

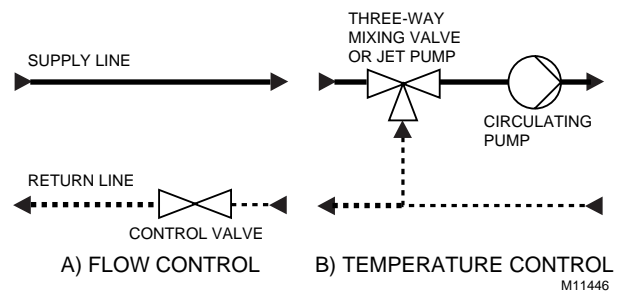

Fig. 130. Two- And Three-Way Valve Configurations for a Heat regulation Unit.

Jet pumps use the effect of injection, making a mechanical pump unnecessary, thereby, saving electrical energy. However, adapting and dimensioning jet pump applications to fit operating conditions is difficult.

Control loops used in a direct substation:

- Supply flow temperature reset on outdoor air temperature.
- Return temperature limit.
- Time schedule functions.
- Night setback and frost protection.

Small Substation For Multiple Family Buildings

Figure 131 shows a typical direct heat transfer substation.

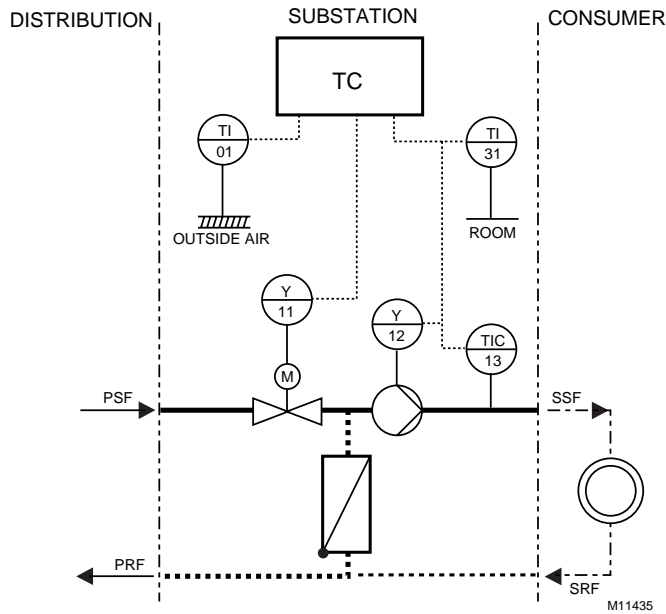

Fig. 131. Small Direct Heat Transfer Substation for Multiple Family Buildings

Table 9. Description of Figure 131 Reference Points.

Reference	Description
TC	Controller
TI 01	Outdoor air temperature sensor
TI 31	Room temperature
TIC 13	SSF temperature
Y 11	Actuator control valve PSF
Y 12	Circulating pump

Control Strategies:

1. Control valve Y 11 maintains the SSF temperature as dictated by TIC 13 which is reset by the outdoor air temperature. Room temperature sensor TI 31 shifts the reset schedule up or down. Controller TC provides night setback and other unoccupied programs.
2. Pump Y 12 provides constant SSF flow through the check valve.
3. Summer operation shuts down the entire station. However, it is recommended that the summer function include a function to exercise the pump and therefore all the devices once a week.

Indirect Heat Transfer Substations

Indirect substations use heat exchangers and physically decoupled or independent heating circuits. Applications range from small substations for a one family house to large substations for industrial types of networks. Three applications for heat transfer substations with different heat exchanger configurations, primary flow and/or the differential pressure is controlled by control valves, heat flow controlled by modulating control valve to vary the primary flow, and circulating pumps to provide the secondary supply and return flow, follow:

Indirect heat transfer substations:

- Transfer the required heat from the supply (primary) side to the consumer (secondary) side.
- Meter heat.
- Provide safety functions to protect consumer and equipment against overheating, frost, and harmful agents in hot tap water.
- Provide optimization functions to reduce energy consumption to the lowest possible level.
- Provide hydraulic separation between the high-temperature high-pressure system and the low-temperature low-pressure system.

The main parts of an indirect substation are:

- Primary side.
- Heat exchanger.
- Circulating pumps.
- Expansion and storage tanks.
- Feed water facilities.
- Secondary side.

Functional principle:

The primary side of the substation (Fig. 132) contains the differential pressure control and a normally closed temperature control valve with safety spring return, if the secondary medium temperature exceeds 100°C. The differential pressure control is used in large networks where over time significant pressure differences exist.

The primary supply flow (from the district heating network) enters the heat exchanger, transfers the heat to the secondary supply flow, and returns to the heat source through the primary return.

In large networks with distributed pressure and temperature parameters the primary flow and/or the differential pressure is controlled by electric or self regulating control valves. This ensures a constant inlet pressure differential regardless of the actual pressure differential pressure in the network. Separate control valves or valves with combined functionality in the return or supply flow ensure this.

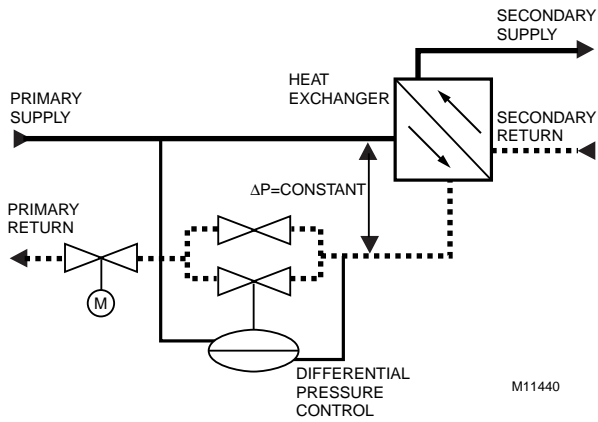

Fig. 132. Primary Side of Indirect Heat Transfer Substation.

The heat exchanger (HEX) separates both circuits and maintains the heat flow between primary and secondary side (Fig. 133). Both plate or tube type heat exchangers are used in either parallel or series configurations. The heat flow is controlled by modulating the control valve position varying the primary flow.

The secondary supply flow temperature setpoint is usually set from the outdoor air temperature during the day and set back during the night. A high limit safety device reduces the supply flow temperature, if the return flow temperature exceeds high limit setpoint.

In addition HEXs are used for domestic hot water either directly or via a charge pump and hot water storage tanks.

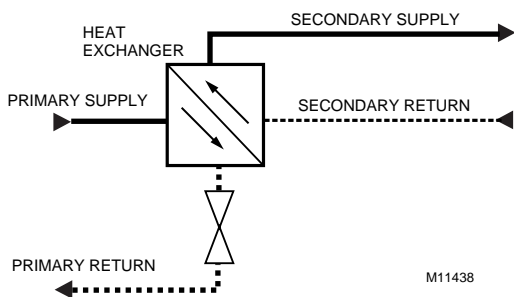

Fig. 133. Heat Exchanger Portion of Indirect Heat Transfer Substation.

Control loops:

Circulating pumps provide the differential pressure between secondary supply and return flow. In facilities where the load varies over a wide range, variable speed pumps are used to meet the pressure requirements and save electrical energy.

The absolute pressure in the secondary circuit must be kept within the safety limits (upper limit to avoid pipe and pump damage, lower limit to avoid water flashing to steam and cavitation).

- In general three different configurations are used:
- Open systems using water column static pressure and expansion tanks.
 - Closed systems (Fig. 134) using pressurized air and expansion tanks (static pressure holding system).
 - Dynamic systems using a combination of pressure holding pumps and vent-valves.

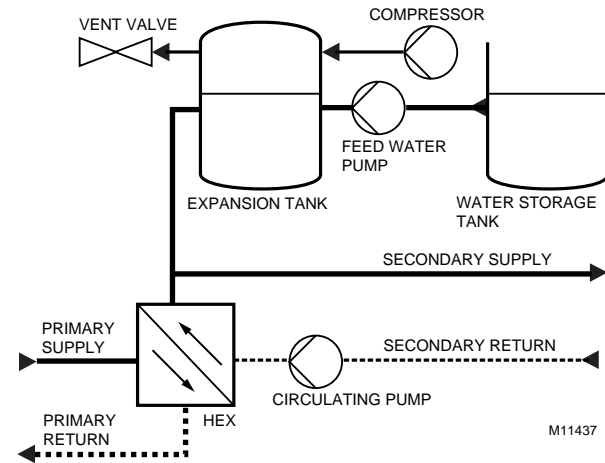

Fig. 134. Feed Water System in Secondary of Indirect Heat Transfer Substation.

Feed water facilities maintain the water level in a heating system. Two ways of feeding water exist depending on the requirements placed on the water quality.

The first method takes water from the primary circuit. This water is of sufficient quality for use in the secondary circuit. Pressure reducing, cooling, and safety (close off) equipment may be necessary depending upon the pressure and temperature level in each circuit.

The second method uses treated tap water. Use of untreated water is not recommended as it can coat system with minerals precipitated from the water and dissolved oxygen can corrode the piping. This method can also be used as a back up to the first method.

Hybrid Heat Transfer Substations

This combines direct heating with indirect domestic hot water supply (DHW) as shown in Figure 135. Sizes range from small substations to large heat exchanger substations supplying several blocks of buildings.

As described before, there are usually three main parts to the substation:

- Primary side including pressure/flow regulating equipment.
- Heat exchanger or hot water storage tank (chargeable) for DHW and heat flow regulating equipment for heating.
- Circulating pumps for secondary side (heating) and for DHW.

The primary side includes shut off valves, differential pressure, and flow control equipment provide safety functions and a required differential pressure or flow. Heat metering is also included. The water flow here is divided into two parts.

circuit and transfers the heat to the consumer directly. The supply flow temperature is controlled by one three-way valve, two two-way valves, or one jet pump making an additional circulation pump redundant.

The HEX transfers the heat from the primary system to the DHW loop. A valve placed in series with the HEX controls the flow. The other part of the primary flow enters the secondary

In cases without a jet pump, circulation pumps provide the needed differential pressure.

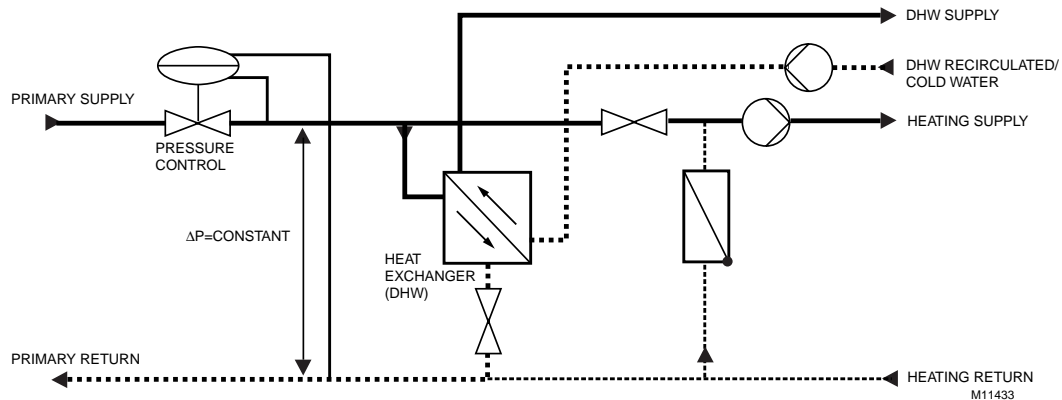

Fig. 135. Hybrid Heat Transfer Substation.

CONTROL APPLICATIONS

DDC CONTROL OF HIGH PERFORMANCE SUBSTATION

Table 10. Description of Figure 136 Reference Points.

Reference	Description	Reference	Description
LIC 56	Water level supervision & control	TI 31	PRF temperature (HEX 12)
LIC 63	Water level supervision & control	TI 47	SRF temperature
PDIC 14	Primary differential pressure	TIC 28	SSF temperature (HEX 1)
PDIC 45	Secondary differential pressure	TIC 38	SSF temperature (HEX 12)
PI 13	PSF pressure	TIC 44	SSF temperature
PI 16	PRF pressure (internal)	TSA+ 22	High temperature limit Primary Return Flow Heat exchanger 1 (PRF HEX 1)
PI 46	SRF pressure	TSA+ 32	High temperature limit (PRF HEX 12)
PI 110	PRF pressure (outdoor)	TSA+ 25	High temperature limit (SSF HEX 1)
PIC 57	SSF pressure	TSA+ 35	High temperature limit (SSF HEX 12)
PLC	S9000 Supervisory Control	TZA+ 26	Safety temperature limit (SSF HEX 1, locked)
PSA+ 52	Safety pressure limit (refill pipe)	TZA+36	High temperature limit (SSF HEX 12, locked)
PSA+ 58	Safety pressure limit (SSF)	TZA+ 41	Safety temperature limit (SSF total, high)
PZA+ 24	Safety pressure limit (high)	Y 11	Actuator valve Primary Supply Flow (PSF)
PZA+ 34	Safety pressure limit (high)	Y 17, Y 18	Actuator control valve (PDPC)
PZA+ 43	Safety pressure limit (SSF high)	Y 19	Safety close off valve
PZA-27	Safety pressure limit (low)	Y 23	Actuator control valve
PZA-37	Safety pressure limit (low)	Y 29	Damper (secondary flow, HEX 1)
PZA-42	Safety pressure limit (SSF total low)	Y 33	Actuator control valve
QIR 53	Metering refill quantity	Y 39	Damper (secondary flow, HEX 12)
QIR 62	Cold water metering	Y 48, Y 49	Secondary flow circulating pumps
QIR 111	Heat metering	Y 51	Actuator valve (water refill from PRF)
TI 01	Outdoor air temperature	Y 54	Vent valve
TI 12	PSF temperature	Y 55	Compressor
TI 15	PRF temperature (total flow)	Y 61	Actuator valve (cold water refill)
TI 21	PRF temperature (HEX 1)	Y 64	Feed water pump

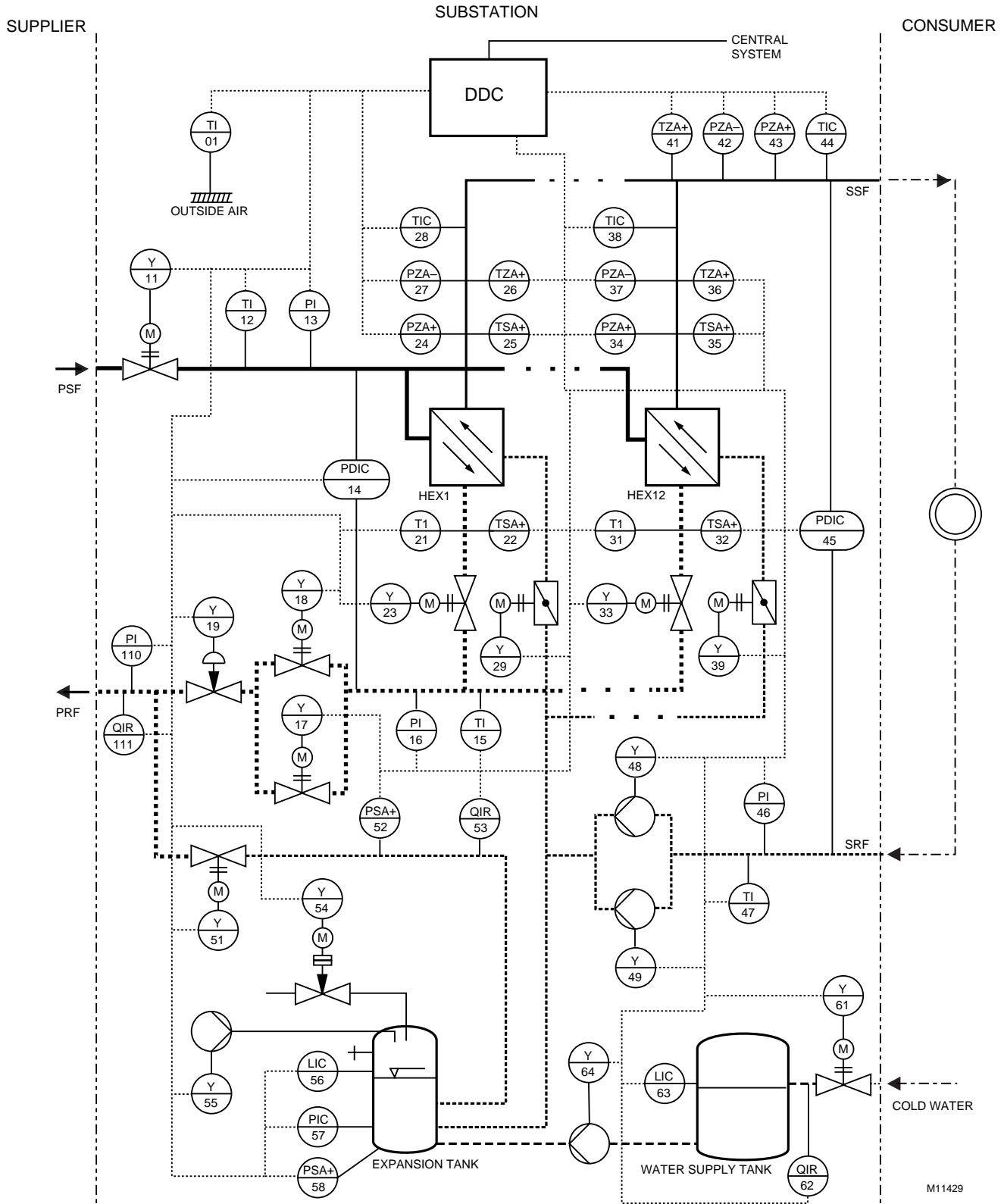

Fig. 136. DDC Control of Large High Performance Indirect Heat Transfer Substation.

Control Strategies

1. Primary Flow Loop Differential Pressure Control: Provides a constant value pressure drop across the heat exchangers. Actuator control valves (Y17, Y18) open or close sequentially to maintain the pressure drop measured by PDIC 14.
2. Secondary Loop Supply Flow Temperature Control: The SSF temperature is reset from outdoor air temperature (Fig. 137). The actual SSF temperature is measured by sensors TIC 28 and TIC 38. The regulation of the heat flow through the HEX is provided by the actuator control valves Y 23 and Y 33 in the primary return flow line of each heat exchanger.
3. Secondary Flow Loop Differential Pressure Control: Circulating pumps Y 48 and Y 49 are switched off or on and the speed varied to maintain the differential pressure setpoint. A frequency converter (fc) controls pump speed.
4. SSF Loop Pressure Control: Maintains the pressure sensed by transmitter PIC 57 within a defined range to avoid too low pressure (vaporization) and too high pressure (pump overload). Vent valve Y 54 maintains the high limit and compressor Y 55 maintains the low limit.
5. Expansion Tank Water Level Control (WLC) Loop: LIC 56 maintains the expansion tank water level. Normally

PRF water through Valve Y 51 provides make-up water, in cases of a high quantity water loss, Pump Y 64 pumps make-up water from the water supply tank. The WLC protects the circulating pumps against running without water.

6. Water Supply Tank Water Level Control: LIC 63) controls Valve Y 61, providing make-up water from the cold water.
7. Secondary Return Flow (SRF) and the Primary Return Flow (PRF) temperatures are limited to provide a high temperature drop between supply and return flow.

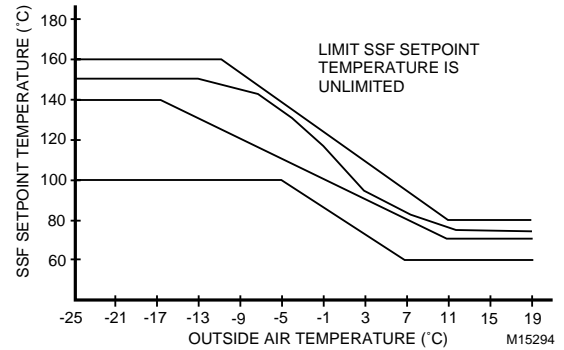

Fig. 137. Adjustment of Temperature Curves.

DDC CONTROL OF A SMALL HOUSE SUBSTATION

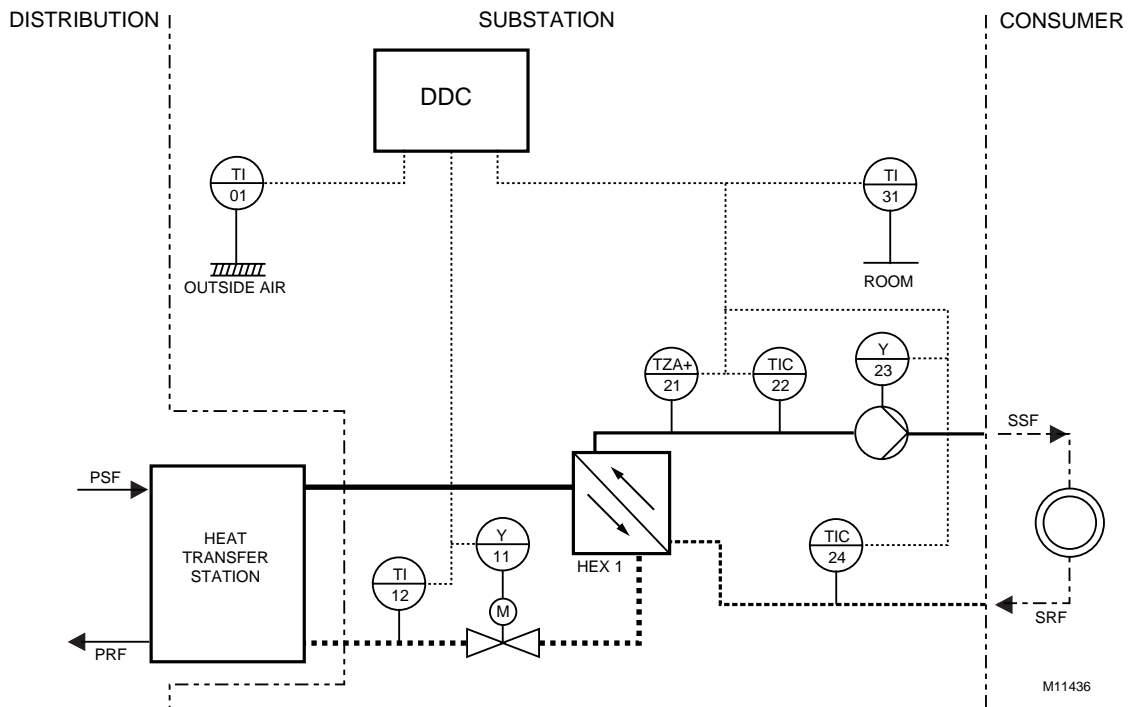

Fig. 138. DDC Control of a Small House Heat Transfer Substation.

Table 11. Description of Figure 138 Reference Points.

Reference	Description	Reference	Description
DDC	Controller	TIC 24	SRF temperature
TI 01	Outdoor air temperature	TZA+ 21	Safety temperature limit (SSF)
TI 31	Room temperature sensor & setpoint setting	Y 11	Control valve PRF
TIC 12	PRF temperature	Y 23	Circulating pump
TIC 22	SSF temperature		

Control Strategies:

1. Primary temperatures: supply up to 130°C, return up to 90°C.
2. Secondary temperatures: supply up to 90°C, return up to 70°C.
3. System provides a SSF temperature depending on the outdoor temperature according to a reset schedule (Fig. 139).
4. Heat demand dependent pump switching, with one full cycle of the pump per day to prevent seizing.
5. Diagnostic functions via connector.
6. PRF temperature limitation with fixed and variable value available. The control valve reduces the flow until the PRF temperature is below the parameter value. The setpoint can be fixed or floating with a certain ΔT below the PSF.
7. SSF temperature limitation available (parameter).

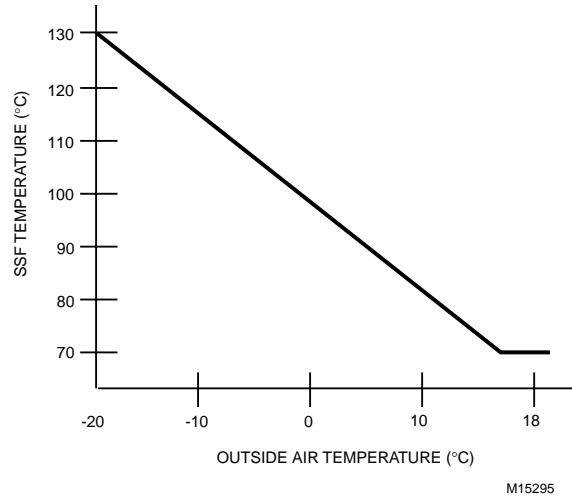

Fig. 139. SSF Temperature Reset Schedule.

CONTROL OF APARTMENT BUILDING SUBSTATIONS WITH DOMESTIC HOT WATER

DDC Control of Two-Stage Heat Exchanger for Heating and Domestic Hot Water.

Table 12. Description of Figure 140 Controls.

Reference	Description	Reference	Description
DDC	Controller	TIC 16	PRF-temperature
PI 11	PSF pressure	TIC 21	DHW temperature (supply flow)
PI 17	PRF Pressure	TIC 31	SSF temperature
PI 22	DHW pressure (supply flow)	TIC 34	SRF temperature
PI 24	DHW pressure (return flow)	Y 13	Actuator valve (SSF temperature control)
PI 28	Cold water pressure	Y 14	Actuator valve (DHW temperature control)
PI 213	DHW network pressure	Y 23	Actuator valve (DHW supply flow)
PIC 32	SSF pressure	Y 25, 26, 27	DHW circulating pumps
PIC 35	SRF pressure	Y 29, 210	DHW pressure booster pumps
QIR 02	Elec. Power metering	Y 31	Actuator valve (SSF)
QIR 15	Heat metering	Y 36, 37	Circulating pumps (secondary fl.)
QIR 214	Drinking water metering	Y 38, 39	Refill pumps (PRF to SRF)
TI 01	Outdoor air temperature	Y 211, 212	DHW pressure booster pumps
TI 12	PSF temperature	Y 310	Actuator valve
TI 215	DHW circulation, return flow temperature		

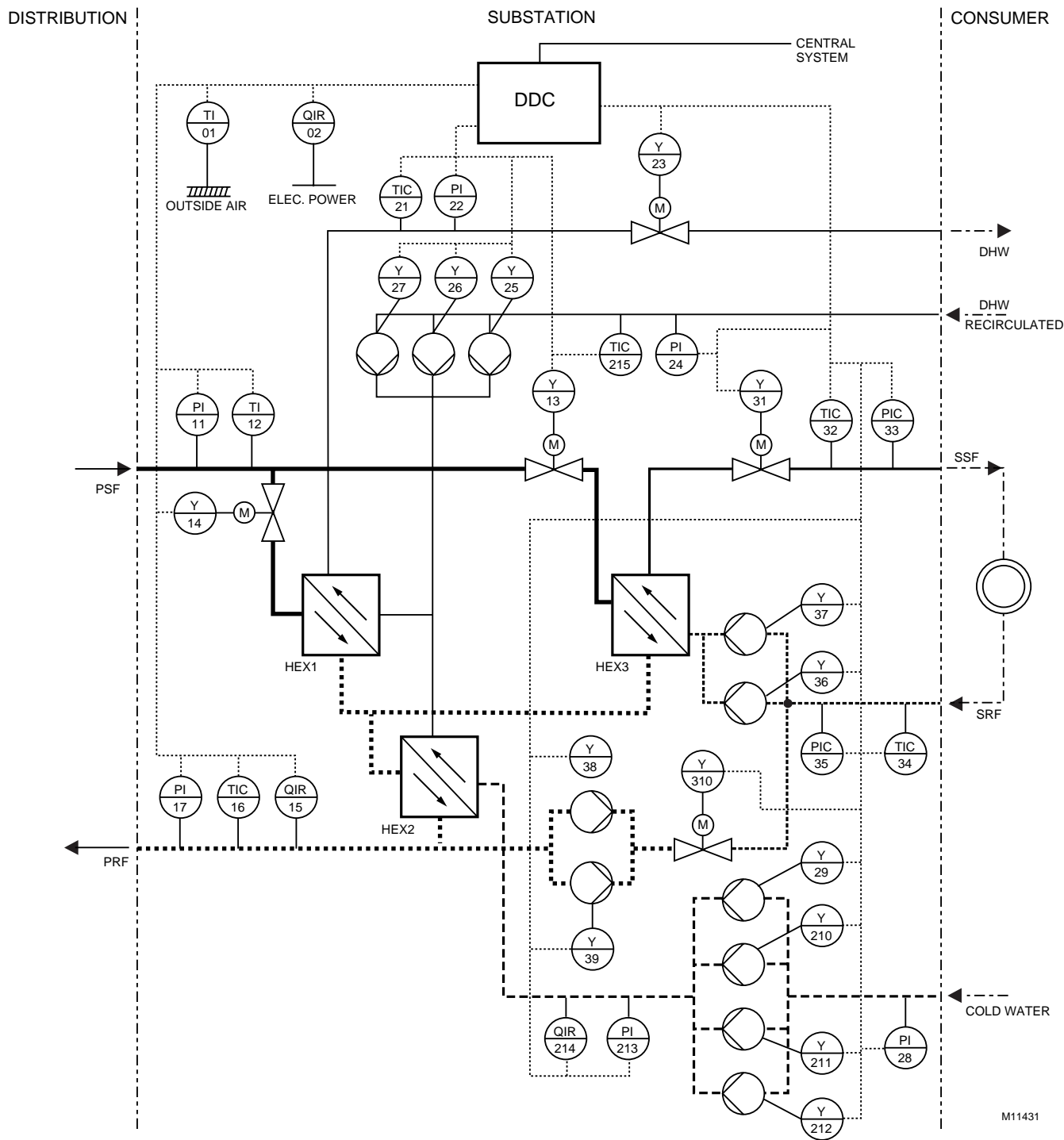

Fig. 140. DDC Control of Two-Stage Heat Exchanger for Domestic Hot Water and Heating.

Control Strategies

1. Secondary Supply Flow Temperature Control: The SSF temperature is reset from outdoor air temperature. TIC 32 provides the SSF temperature to the DDC controller. Valve Y 13 regulates flow through HEX3 primary.
2. Secondary Flow Loop Differential Pressure Control: Circulating pumps Y 37 and Y 36 are switched off or on and the speed varied to maintain the differential pressure setpoint. The pump speed is controlled by a frequency converter (fc).
3. Secondary Supply Flow Temperature Control: The SSF temperature is reset from outdoor air temperature (Fig. 141). The actual SSF temperature is measured by sensor TIC 32. The regulation of the heat flow through the HEX is provided by the actuator control valves Y 13 in the primary supply flow line of HEX3.
4. Secondary Loop Make-up Water: Pumps Y 38 and Y39 through Valve Y 310 provide make-up water from the PRF.
5. DHW Pressure Control: Booster Pumps Y29, Y210, Y211, and Y212 boost the cold water pressure to the pressure at PI 213.

6. DHW Circulating Pumps Control: Circulating Pumps Y 25, Y26, and Y27 circulate DHW through the pipes to maintain hot water temperature at the end of the DHW system.
7. DHW Supply Temperature: Valve Y 14 modulates the PSF water to HEX 1 and HEX 2 to maintain the DHW supply temperature at Y 27.

Functional Diagram

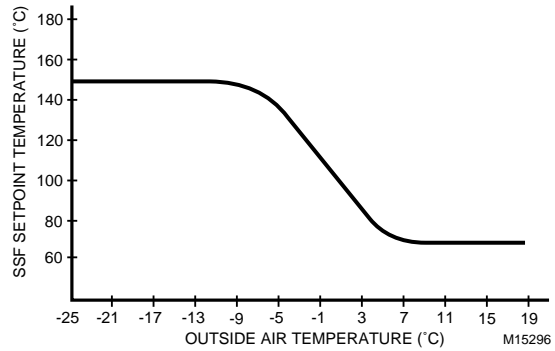

Fig. 141. Secondary Supply Flow Temperature Reset schedule.

DDC Control of Combination Heat Exchanger and Domestic Hot Water Storage Tank

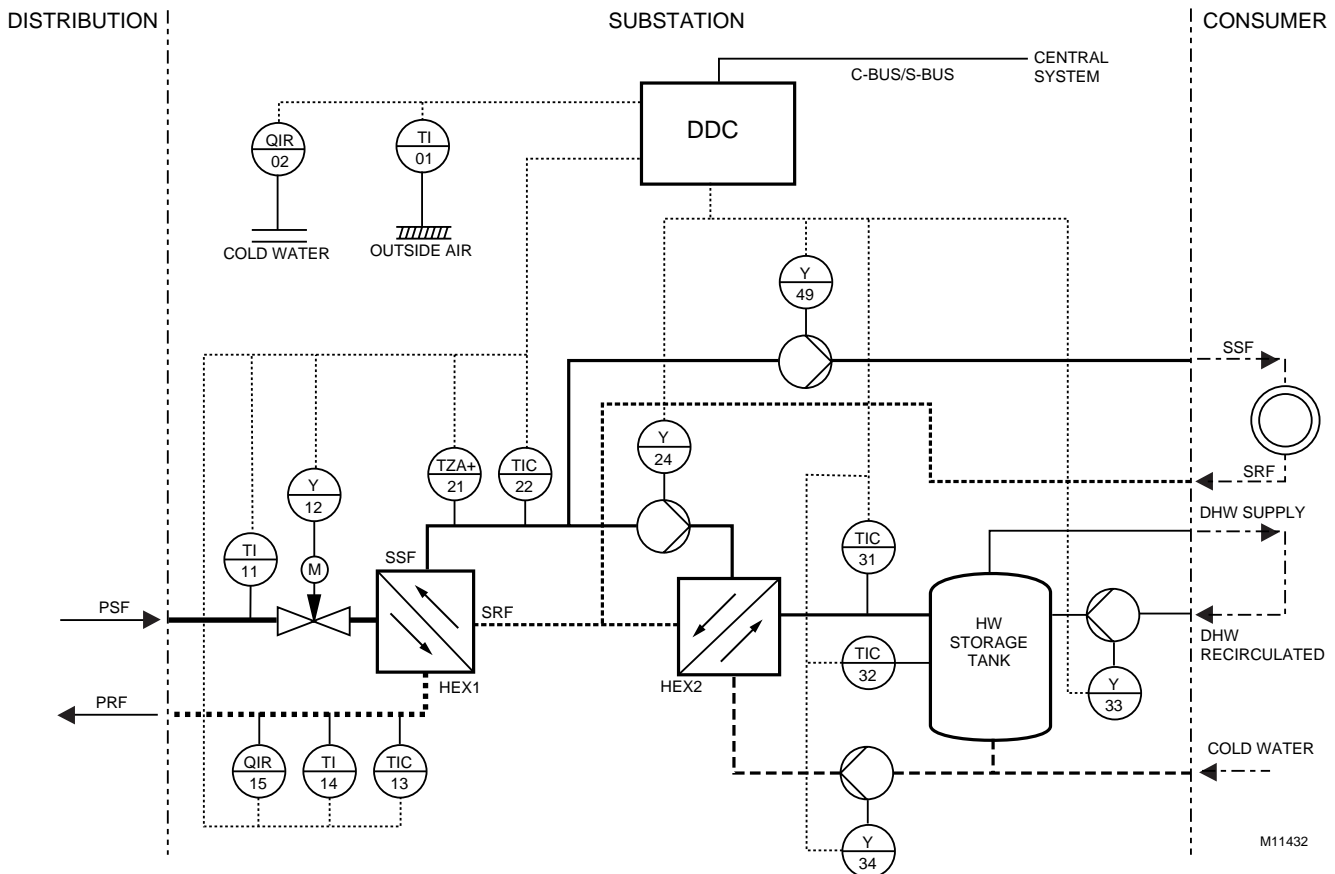

Fig. 142. DDC Control of Dual Heat Exchangers for SSF and DHW Storage.

Table 13. Description of Figure 142 Controls.

Reference	Description
DDC	Controller
QIR 02	Cold water metering
QIR 15	Flow meter (heat meter)
TI 01	Outdoor air temperature
TI 11	PSF temperature
TI 14	PRF temperature (heat meter)
TIC 13	PRF temperature
TIC 22	SSF temperature
TIC 31	Loading circuit temperature
TIC 32	HW storage tank temperature
TZA+ 21	High temperature limit (SSF)
Y 12	Control valve primary flow
Y 23	Circulating pump (SSF)
Y 24	Circulating pump (SSF)
Y 33	Circulating pump
Y 34	Charging pump (HW storage tank)

Control Strategies

1. Secondary Supply Flow (SSF) temperature control: Modulating normally-closed Valve Y 12 in the primary supply flow (PSF) and TIC 22 control the SSF temperature. The SSF setpoint is reset based on outdoor air temperature (Fig. 143). If the primary return flow (PRF) exceeds the TI 14 temperature limit, the SSF 1 temperature reset schedule is adjusted to a lower temperature schedule. If the SSF temperature exceeds the high limit setpoint of hard wired thermostat (TZA+ 21), power to valve Y 12 is shut off closing the valve.

erature schedule. If the SSF temperature exceeds the high limit setpoint of hard wired thermostat (TZA+ 21), power to valve Y 12 is shut off closing the valve.

2. DHW temperature control: Valve Y 12 in conjunction with TC 32 maintains the HW storage tank water temperature. Thermostat TIC 32 supplies the HW storage tank loading cycle start point. During the loading cycle, SSF water heats HEX 2, other loads are switched off, and the pumps Y 24, Y 34 load the HW storage tank. Temperature sensor TIC 31 turns loading operation off.
3. DHW Circulating pump control: Circulating pump Y 33 is time schedule controlled to maintain the DHW temperature at the end of the line.

Functional Diagram

Variations of temperatures based on a heat surface factor (HSF) of radiators in a building (equivalent to a building heat curve variation) ranging from 0.8 to 1.6 (Fig. 143).

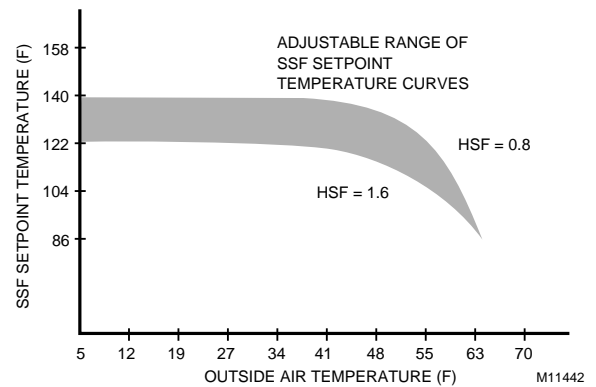

Fig. 143. SSF Temperature Reset Range.

HYBRID BUILDING SUBSTATION

Combination Jet Pump and Heat Exchanger.

The Heating System is mainly used in Eastern Europe or the CIS and consists of a Hydro-elevator Mixing Valve (jet pump). Hydro-elevators are mostly uncontrolled devices, mixing the

building return water with supply water according to the hydro-mechanical configuration in the valve and requires no pump for heating water circulation in the building heating system (Fig. 144).

Table 14. Description of Figure 144 Controls.

Reference	Description	Reference	Description
DDC	Controller	TI 16	SSF temperature
HEX 1	Heat exchanger	TI 18	SRF temperature
QIR 12	Primary flow meter	TI 19	PRF temperature
QIR 17	Secondary flow meter	TI 32	Heating return temperature
TI 01	Outdoor temperature	TIC 21	DHW supply temperature
TI 11	PSF temperature	TIC 31	Heating supply temperature
TI 13	PSF temperature	Y 14	DHW control valve
TI 15	PRF temperature	Y 33	Heating control valve

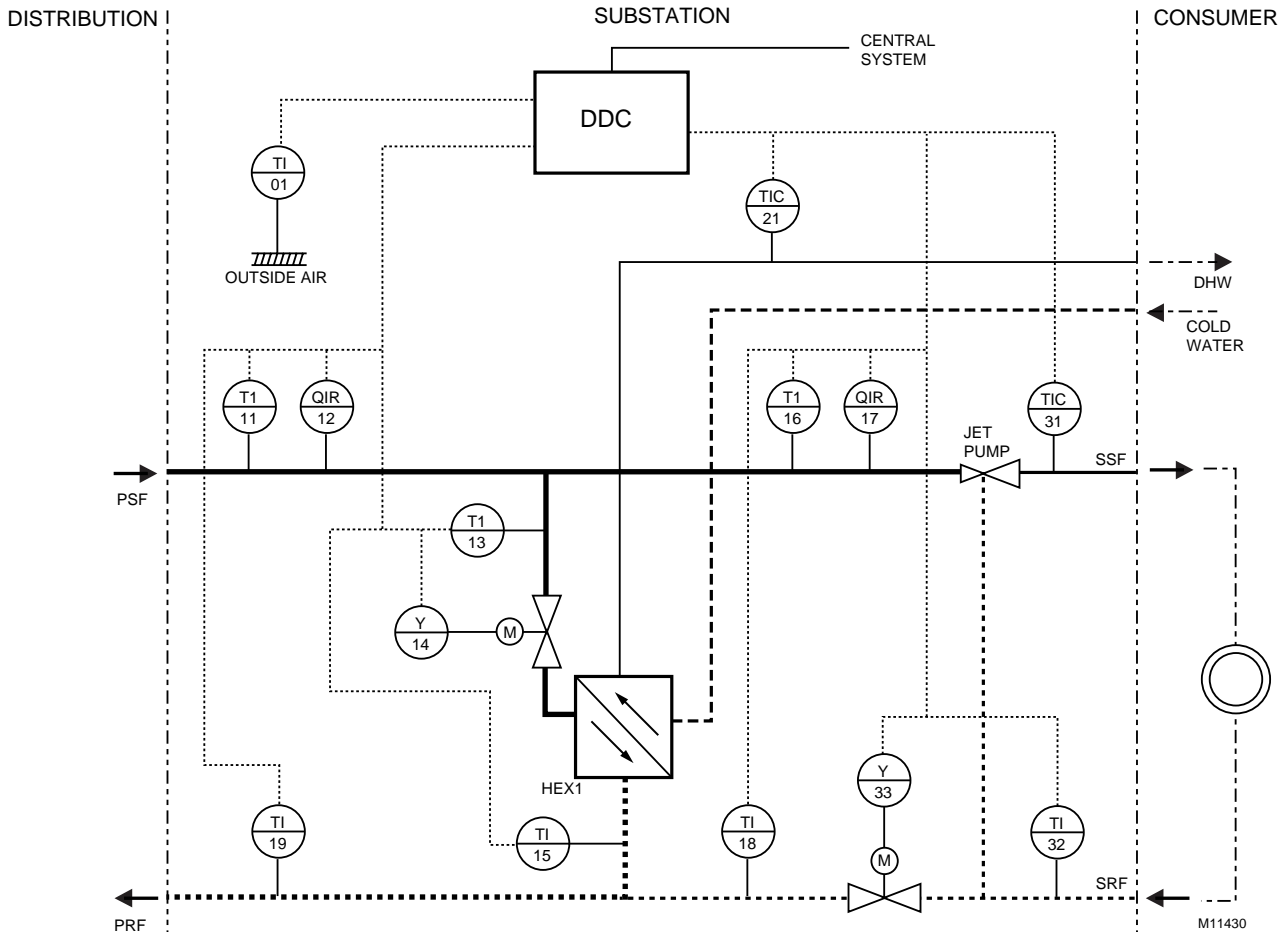

Fig. 144. Control of Heat Exchanger for DHW and Jet Pump for SSF.

Control Strategies

1. The SSF temperature depends on the mixing ratio of the jet pump. Jet pumps do generally not require secondary circulation pumps. Valve Y 33 on the return pipe provides a limited amount of flow control. As the valve varies from full open to 30%, flow through the jet pump varies from full flow. When the valve is less than 30% open, SSF flow cannot be guaranteed. TI 32 controls Y33 to maintain the SRF temperature as reset from outdoor air.
2. Heat exchanger HEX 1 Transfers heat to the isolated domestic hot water system (DHW). Control valve Y 14 in conjunction with temperature sensor TIC 21 control the DHW temperature. Because the amount of DHW in the heat exchanger is small, a fast control system response time is required. The response times should be:

Controller	cycle time	< 1 sec.
Actuator	on/off time	< 1 sec.
Sensor	rise time	< 2 sec.

Individual Room Control Applications

ENGINEERING MANUAL OF AUTOMATIC CONTROL

CONTENTS

Introduction	397
Graphic Symbols	398
Abbreviations	399
Air Terminal Unit Control	399
Variable Air Volume ATU	399
Pressure-Dependent and Pressure-Independent ATU	399
Single-Duct VAV ATU	400
System Configuration	400
Throttling VAV ATU	400
Variable Air Volume ATU	401
Variable Air Volume ATU with Electric Reheat	402
Constant Air Volume ATUs	402
Induction VAV ATU	402
Parallel Fan ATU	404
Series Fan ATU	404
Dual-Duct ATU	406
Dual Duct Pressure Independent VAV ATU	406
Dual Duct Pressure Independent Constant Volume ATU	407
Unitary Equipment Control	408
General	408
Natural Convection Units	408
Radiant Panels	409
Unit Heaters	409
General	409
Control	410
Two-Position Control	410
Modulating Control	410
Down-Blow Unit Heater	410
Gas- or Oil-Fired Unit Heater	411
Unit Ventilators	411
General	411
Control	412
ASHRAE Control Cycles	412
Standby/Warmup Stage	412
Cycle I—Fixed Maximum Percentage of Outdoor Air	413
Cycle II—Fixed Minimum Percentage of Outdoor Air	413
Cycle III—Variable Outdoor Air	414
Day/Night Setback Control	414
Unit Ventilator Digital Control	415
Precautions and Conditions for Successful Operation	418
Blocked Airflow	418
Power Failure	418
Coil Freeze-Up	418

INDIVIDUAL ROOM CONTROL APPLICATIONS

Fan Coil Units	418
General	418
Two-Pipe Heating/Cooling	419
Two-Pipe Heating/Cooling, Single Coil	419
Four-Pipe Heating/Cooling, Split Coil	420
Four-Pipe Heating/Cooling, Single Coil	420
Heat Pumps	421
General	421
Operation	421
Control Loops	422
Individual Room Control Automation	423
Hot Water Plant Considerations	424

INTRODUCTION

This section describes applications for air terminal units and unitary equipment used in individual room control. The air terminal units covered include variable- and constant-volume units connected to single- and dual-duct air handling systems. The unitary equipment described includes natural convection units, radiant panels, unit heaters, unit ventilators, fan coil units, and heat pumps.

In individual room control, the control of a room or space is maintained by a room sensor and a controlled device such as a valve or damper actuator, a burner unit, or a compressor. The method of control may be pneumatic, thermal, electric, electronic, or digital. As environmental and standard code requirements change, the control system can be upgraded to enhance the operating capabilities of the system and the terminal units, resulting in complex control strategies for each type of terminal unit.













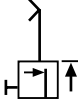





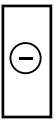

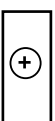

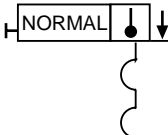
Applications presented in this section are based upon DDC and a BMS. If a BMS is not available, control remains unchanged and the BMS displayed data points should still be available for operators and technicians via a portable terminal. Simple systems such as unit heaters are also shown in Electric Control Fundamentals section.

Large air handling units and chiller plants typically use general purpose digital controllers, while rooms typically use controllers designed for room control. Thus, a VAV box controller may be configured to control a variety of VAV boxes in a variety of ways, but cannot be programmed to control a multi-zone unit. Specifiers of room control strategies must check with vendors to be sure the specified applications can be performed within available products. Many room control schemes are used today. This section presents only a few of the more common ones. Room control strategies must be coordinated with primary air and water systems to assure compatibility.

Control schemes are presented in a BMS graphic display format, including software and some engineering data. Automation concepts are presented at the end of this section. With most room units, several units may be combined on a single display for operator simplicity. Although valuable in this discussion, the level of technical data could overwhelm the nontechnical operator. In all cases the data displays should consider the user's need to know and ability to understand.

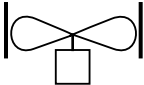
GRAPHIC SYMBOLS

The following symbols are used in graphic displays in this section. These symbols denote the nature of the device, such as a thermometer for temperature sensing.

	CONTROLLER, TEMPERATURE		FAN
	SENSOR, TEMPERATURE		PRESSURE CONTROLLER, HIGH LIMIT CUT-OUT, MANUAL RESET
	LOW LIMIT		PRESSURE SENSOR
	HIGH LIMIT		
	MANUAL RESET NOTATION		COOLING COIL
	INSERTION TEMPERATURE SENSOR		HEATING COIL
	TEMPERATURE SENSOR, AVERAGING		FILTER
	TEMPERATURE CONTROLLER, MANUAL RESET, SAFETY LOW LIMIT		PUMP
	MANUAL MULTI-STATE COMMAND (ON-OFF-AUTO)		SOLENOID VALVE
	STATUS POINT		SMOKE DETECTOR (NFPA SYMBOL)
	VALUE POINT (% LOAD)		PROPELLER EXHAUST FAN
	COMMANDABLE VALUE		
	3-WAY VALVE WITH ACTUATOR		
	2-WAY VALVE WITH ACTUATOR		
	DAMPER WITH ACTUATOR		

M15150

ABBREVIATIONS

The following abbreviations are used:

- BMS** — Building Management System
- ATU** — Air Terminal Unit
- VAV** — Variable Air Volume
- ZEB** — Zero Energy Band
- DDC** — Direct Digital Control
- CAV** — Constant Air Volume

AIR TERMINAL UNIT CONTROL

Air terminal units (ATUs) regulate the quantity and/or temperature of conditioned air delivered to satisfy the temperature requirements of a room or space. ATUs are classified by air handling system design and are available in many configurations. For information on the air supply to ATUs, refer to the Air Handling System Control Applications section and the Building Airflow System Control Applications section.

ATU controls can be as basic as a room sensor controlling a damper or as complex as a room sensor and an airflow sensor operating a damper and a reheat coil valve. In all cases, an individual room control application controls the environment of the room or space. Figure 1 shows basic individual room control with an ATU.

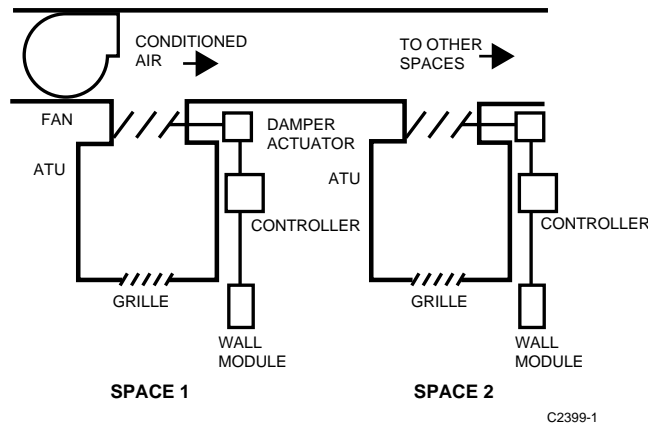

Fig. 1. Basic Individual Room Control.

VARIABLE AIR VOLUME ATU

A variable air volume (VAV) ATU controls the cooling of a space by varying the amount of conditioned air supplied rather than changing the temperature of the conditioned air. Most VAV systems provide energy savings by reducing the load on the central fan when cooling loads are less than design and avoid reheating cooled air.

A system designed to reduce overall system airflow as ATUs shut down offers the greatest energy savings because system fans and fan motors operate at lighter loads. These paragraphs describe the operation of VAV ATUs in single-duct and dual-duct air handling systems.

PRESSURE-DEPENDENT AND PRESSURE-INDEPENDENT ATU

A Pressure-dependent ATU is affected by changing duct static pressures. It may have mechanical minimum and maximum airflow limits.

A pressure-independent ATU automatically adjusts to duct static pressure changes because it contains airflow sensors and controllers to compensate for pressure changes. When used with DDC systems, the pressure-independent ATU may be programmed to change the airflow delivered based on the operating mode. Table 1 describes some modes with the associated command and comments on the reasoning.

Table 1. AHU Operating Modes and Associated ATU Airflow Settings.

Mode	Command	Comments
Smoke Purge Mode	All associated boxes to 82% maximum airflow.	AHU was sized with diversity such that the total box maximum airflows exceed the fan design airflow.
Thermal or IAQ Pre-Purge	All the boxes to 50% maximum airflow.	Take advantage of the fan motor power cube root relationship to airflow (fan runs twice as long at one eighth the motor power).
Preoccupancy Cool Down	Perimeter boxes to 50% maximum airflow and the interior boxes to 80% maximum airflow.	Reduce the fan energy per cubic meter of air delivered by half, match the fan-to-chiller load for better chiller efficiency and for better dehumidification.

SINGLE-DUCT VAV ATU

System Configuration

Figure 2 is a schematic of the equipment shown in the control diagram Throttling VAV ATU in Figure 3. The elements are:

1. Flow control damper.
2. Damper actuator, usually electric, bidirectional.
3. A digital controller.
4. A low voltage control transformer.
5. A line voltage power source.
6. A digital communications bus for control and BMS functions.
7. An optional bus connection to the space wall module for easy access from a portable control terminal.
8. A wall module.

In this pressure dependent application, the damper has minimum and maximum software control positions. In other applications, the controller can have connections to the air flow rings, reheat valve or electric heat contactors, occupancy sensor input, and fan relays.

The wall module contains any combination of temperature sensor, setpoint adjustment knob, after hour override push button, occupancy status LED, or an LCD display and keypad.

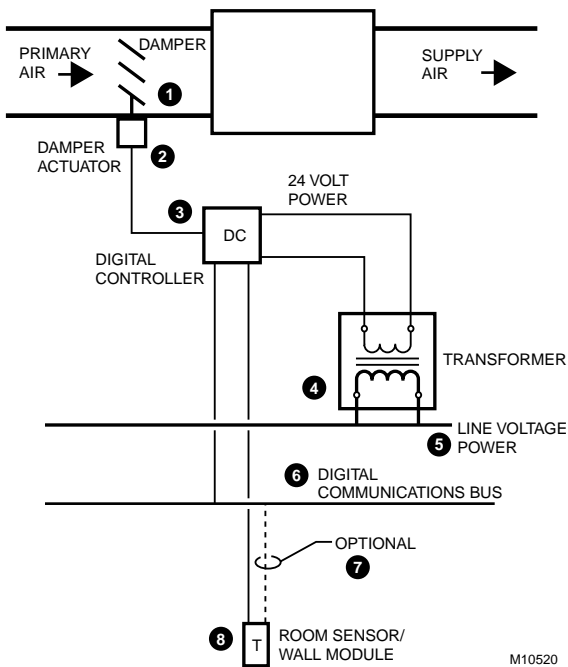

Fig. 2. Single-Duct VAV ATU

In a single-duct VAV ATU, a temperature controller connected to a damper actuator controls the volume of cool air delivered to the space. A reheat coil may be added, in which case the controller sequences the operation of the damper and the valve or contactor. On a full in space cooling load, the damper goes to minimum position before any heat is provided. A single-duct VAV system may also have a separate perimeter heating system such as a finned-tube radiator or fan coil units to satisfy heating requirements.

Throttling VAV ATU

The throttling VAV ATU (Fig. 3) is the simplest and least expensive ATU. A room controller controls the operation of the damper actuator using PI control. The throttling VAV ATU usually has software minimum and/or maximum damper position limits for limiting air volume. Because the unit is pressure dependent, volume at any given damper position varies with the inlet duct static pressure. Maintaining a stable duct static pressure at the end of the duct run is important for proper operation. Proper setting of the minimum-flow limit is essential for adequate circulation and is properly set with all boxes operating at their minimum damper positions. At this operating point, the duct static pressure near the fan will be lower than at full load. If the minimum damper positions are each set with other boxes at their maximum damper positions, when the load decreases and the pressure drops near the fan, inadequate circulation results at boxes near the fan. Compromises in minimum and maximum airflow control on pressure dependent systems result if the loads vary. Care must be exercised in set-up and balancing to assure that all zones get no less than minimum air flow at all loadings and that all zones demanding maximum air flow get no less than maximum air flow at all loadings.

The space temperature setpoint is the value set by the occupant on the wall module. With this option, the BMS operator may assign software limits to the set value. Values may be set outside the limits but the control program ignores them and operates at the limits set in software. Another option frequently used in open and public spaces is to have no setpoint knob on the module and to have a single software setpoint displayable and commandable from the BMS.

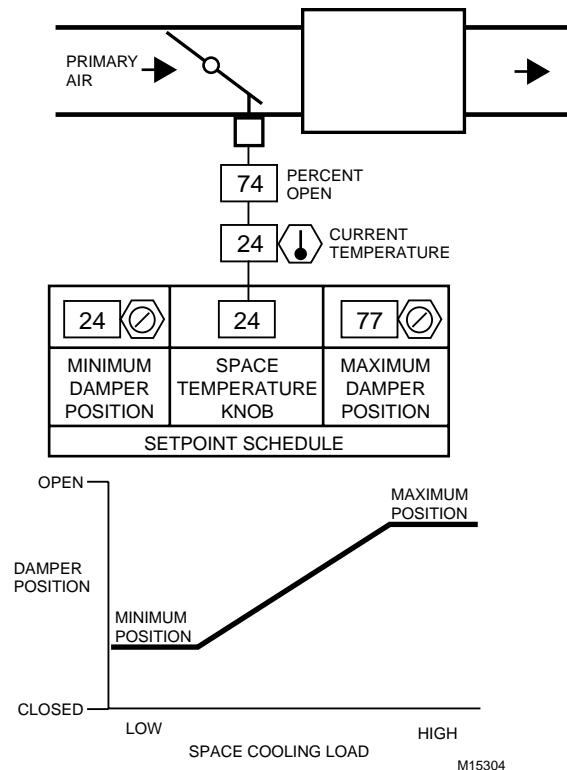

Fig. 3. Throttling VAV Air Terminal Unit.

Figure 4 shows a reheat coil added to a throttling VAV ATU. In this application, the temperature controller sequences the operation of the damper actuator and the control valve or reheat coil. The coil can be replaced by single or multiple stages of electric resistance heat. The damper modulates under PI control at the cooling setpoint and the hot water valve modulates under a separate PI control at the heating setpoint, with a deadband between heating and cooling. In this example, the space occupant can adjust the wall module temperature cooling setpoint (displayed as SPACE TEMPERATURE in the setpoint schedule) and the BMS operator can adjust for the deadband between cooling and heating.

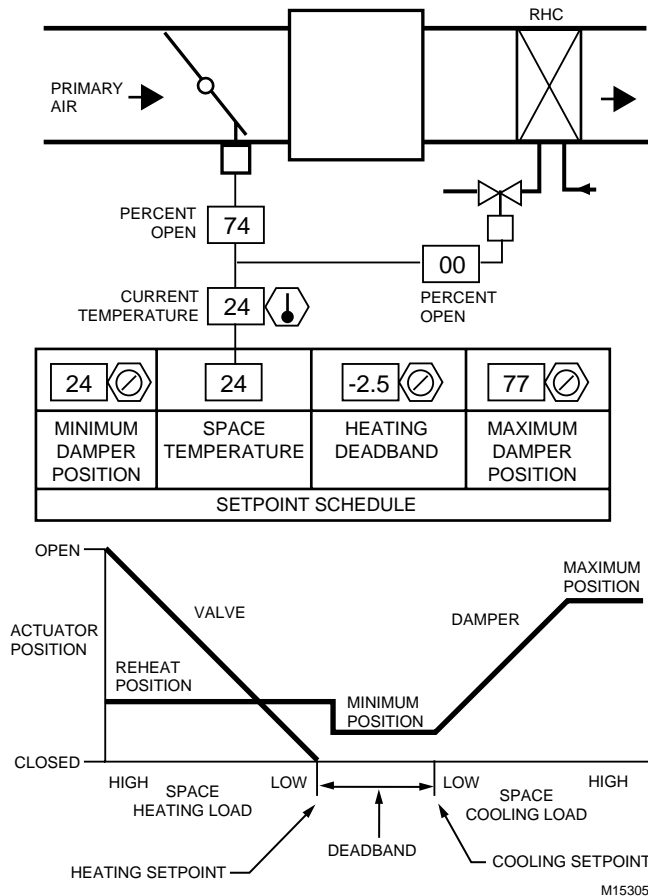

Fig. 4. Throttling VAV Air Terminal Unit with Reheat Coil.

An economical alternative to reheating air that has been cooled or reducing the reheat requirement is to reset the setpoint of primary air in the central fan system conditioning section. Primary air reset limits are usually required to assure adequate dehumidification.

The VAV ATU configurations in Figures 5 through 9 are pressure-independent.

Variable Air Volume ATU

The variable air volume ATU (Fig. 5) is a pressure-independent unit which delivers the required air volume to the space regardless of the supply static pressure. The amount of air delivered is derived from a space temperature PI loop. A flow sensor in the supply air flow modulates the damper actuator to control air volume. The room sensor resets the air flow setpoint as the space thermal load changes. The air flow control loop can be set to maintain minimum air flow at light load conditions, while, maximum air flow can be set to limit flow to meet design conditions. A single wall module can be directed to multiple controllers to control multiple ATUs with the same or differing volume ratings.

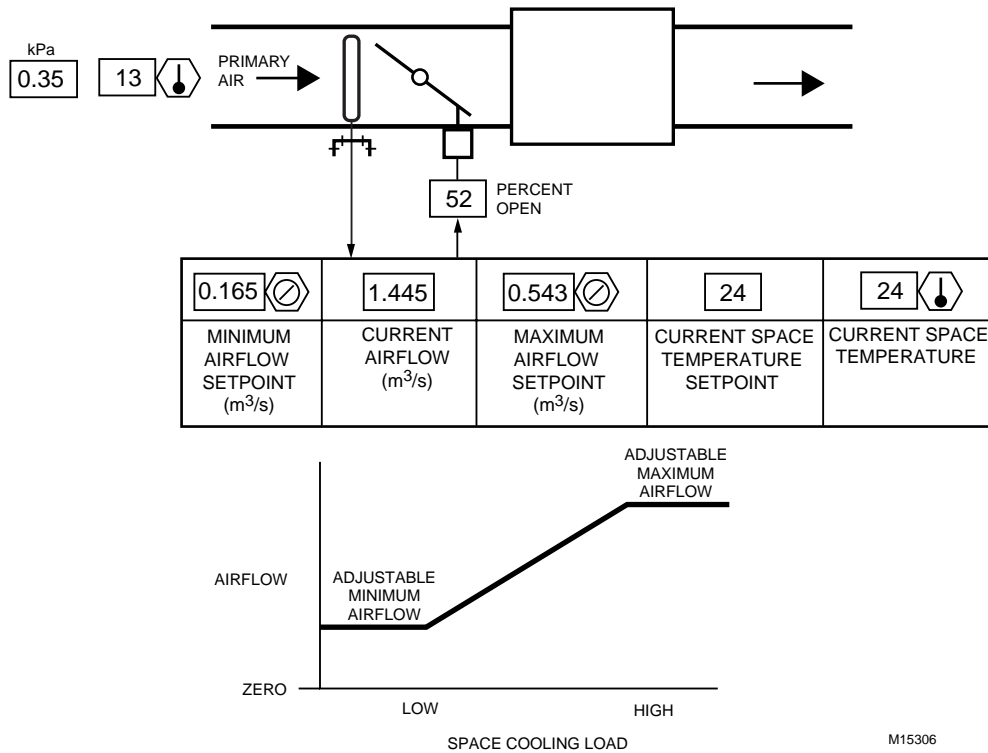

Fig. 5. Variable Air Volume Single-Duct Air Terminal Unit.

Figure 5 displays the primary supply air temperature and static pressure. These values are data points in the AHU digital controller and not physical points at the VAV box. They will vary when measured at the VAV boxes. When a BMS user looks at a VAV box display, it is usually because a problem exists. The fan system supply air temperature and static pressure are necessary data for problem analysis.

bypass push-button override time in minutes, smoke purge mode % of maximum airflow setpoint, smoke pressurization mode % of maximum airflow setpoint, and unoccupied mode % of maximum airflow setpoint.

NOTE: On-off electric heat control often requires a minimum air velocity above that of the minimum cooling airflow to prevent excessive heating element temperatures.

Variable Air Volume ATU with Electric Reheat

The VAV ATU with electric reheat in Figure 6 adds reheat to Figure 5. Figure 6 also shows four boxes on one display. The cooling PID varies the box airflow from maximum to minimum as the cooling load drops to maintain setpoint. If the cooling load drops further, the space temperature drops through a dead band until the heating setpoint is reached, at which point the heating unit is controlled to maintain the heating setpoint. When electric reheat is used, the heating PI may be modified with software heat anticipation to advance the heater stages off command to minimize wide swings in space temperature which would result from simple temperature sensed control.

Although Figures 3, 4, 5, and 6 show several inputs, outputs, and setpoints, many more parameters are available and necessary to allow technicians to adapt the standard program to a unique room and set of equipment. These additional parameters, usually addressable and commandable from the BMS or portable terminal, include the cooling loop PI gains, the heating loop PI gains, reheat airflow setpoint, unoccupied space temperature setpoint, standby temperature setpoint, temperature sensor calibration offset, bypass push-button status,

Constant Air Volume ATUs

The constant air volume (CAV) ATUs are similar to the pressure independent VAV units, except they control at a single air volume setpoint. They usually include reheat coils, an associated room sensor that controls the heating, and are often found connected to VAV AHUs which also have VAV boxes and the associated varying duct static pressures. CAV units are used where the room supply air volume must be maintained at a constant value.

Induction VAV ATU

The induction VAV ATU (Fig. 7), uses induced return air as the initial reheat medium. Induction VAV ATUs are usually installed above the ceiling and draw return air from the plenum created by a false ceiling. The controller resets the primary air airflow control setpoint in unison to opening the return air dampers per the operation cycle shown in Figure 7. As the dampers open, more return air is induced into the unit and recirculated into the space.

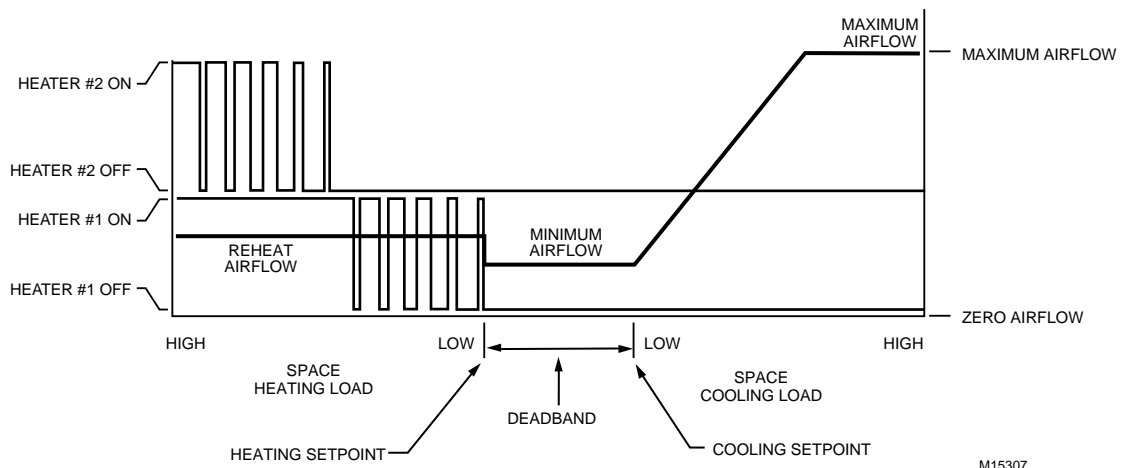
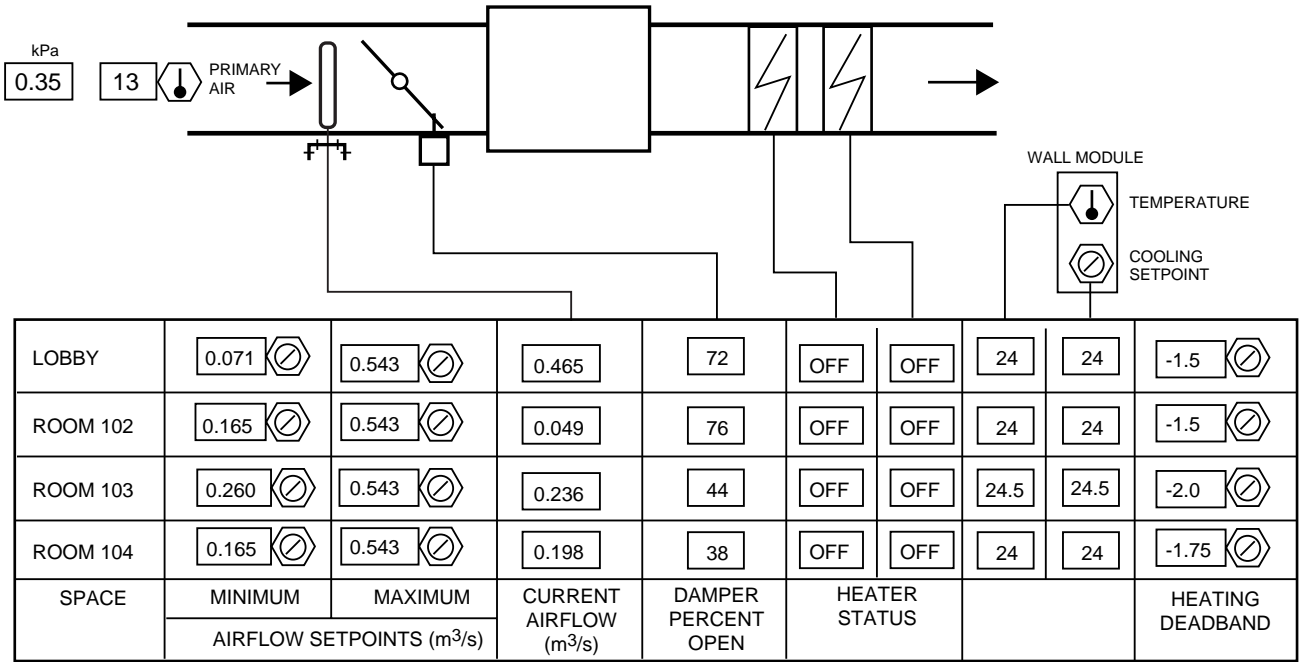

Fig. 6. Variable Air Volume Single-Duct With Reheat Air Terminal Unit.

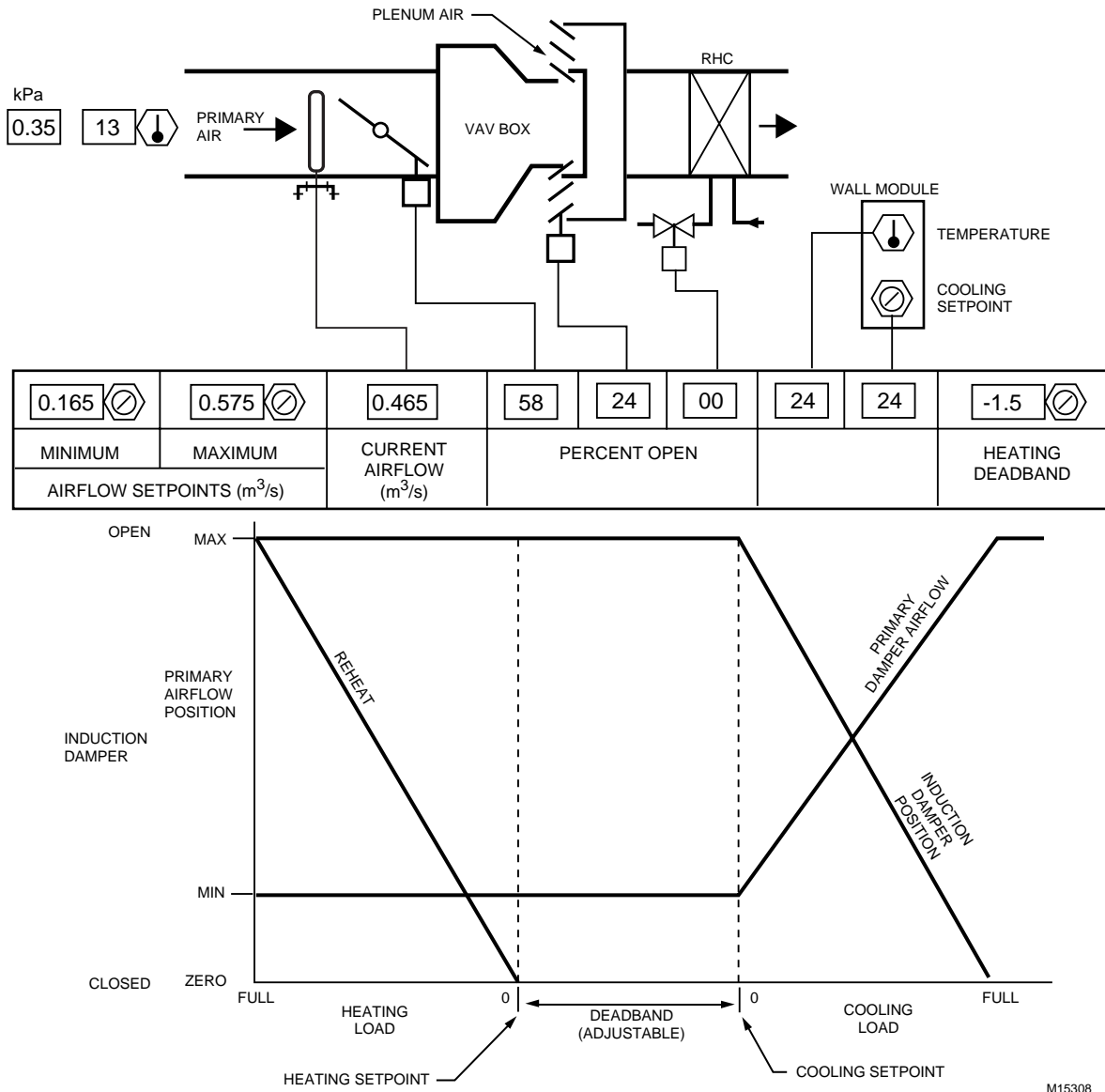

Fig. 7. Induction VAV Air Terminal Unit.

The induction VAV ATU maintains more air motion in the space at lower loads than a throttling VAV ATU. The reheat coil is optional, and may be in the induced air or supply air.

Parallel Fan ATU

The parallel fan ATU (Fig. 8) replaces the induction VAV ATU damper with a small centrifugal fan to recirculate return air at a constant volume after primary air decreases. The fan acts as the first stage of reheat after primary flow is at minimum or can be switched on at a low primary flow threshold while primary flow goes to zero. The reheat coil is optional.

The operation cycle in Figure 8 shows that when space temperature is below the heating setpoint, the primary air flow is at a minimum, and the fan is on. As the heating load goes to zero, the reheat valve closes, then the fan stops. After the space temperature rises through a deadband, as the cooling load increases, the primary air flow increases to maximum.

Series Fan ATU

The series fan ATU (Fig. 9) delivers a constant volume of discharge air with a variable volume of AHU supply air. In this ATU, the fan is on continuously during occupied hours. Primary air is modulated to meet space demand for cooling. As primary air damper modulates closed, more plenum air is drawn in to maintain a constant discharge volume. Optional reheat can be sequenced as required.

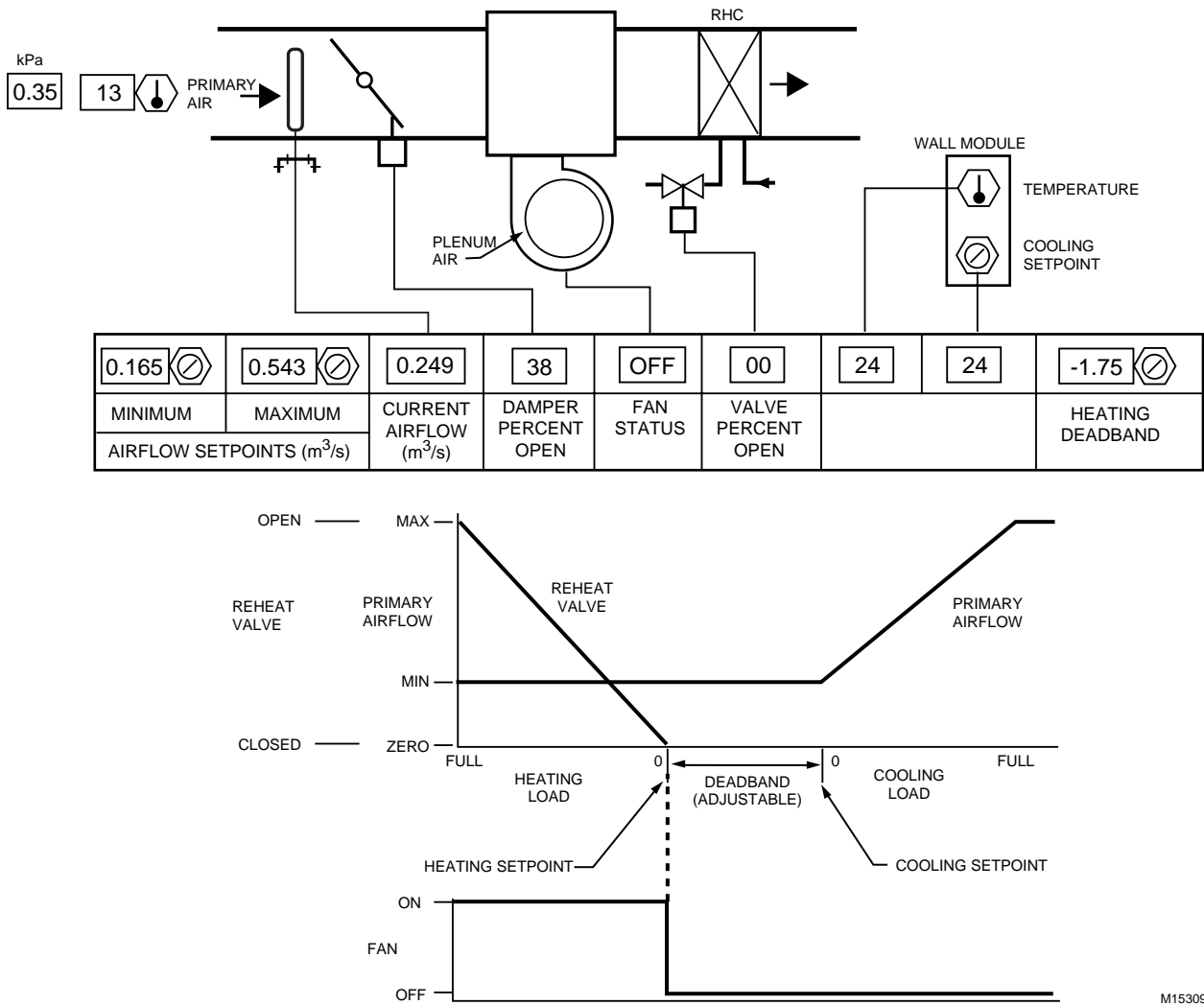

M15309

Fig. 8. Parallel Fan Air Terminal Unit.

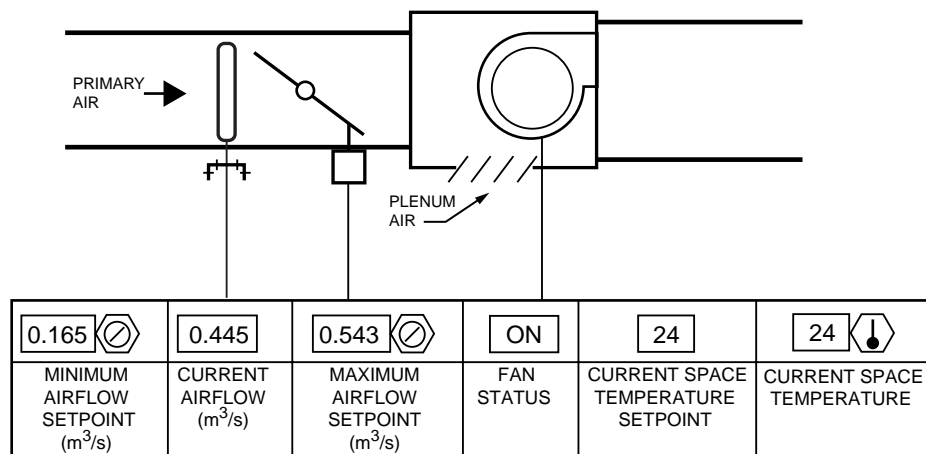

M15310

Fig. 9. Series Fan Air Terminal Unit.

DUAL-DUCT ATU

In a dual-duct air handling system, supply air is divided at the central fan and hot air and cold air flow through separate ducts throughout the building. Two of the many DDC dual-duct control configurations are included here.

A typical original dual-duct ATU draws hot and cold air from respective ducts, mixes the air as directed by a sensor in the controlled space, and discharges the mixed air into the space. This basic dual-duct mixing system is not economical because air is cooled and heated much of the year. DDC systems are still sometimes used with digital hot and cold duct load reset to minimize the energy waste during mixing periods. Adapting dual-duct systems to VAV control has resulted in significant energy savings without discomfort.

Dual Duct Pressure Independent VAV ATU

Figure 10 shows a dual-duct pressure independent ATU. The airflow sensor in the outlet of the ATU controls the cold duct inlet damper to the cooling maximum airflow to the minimum ventilation airflow, through the dead band, and to the heating setpoint. As the heating load increases, the hot duct damper modulates open to control the supply airflow from zero to the maximum heating value. This same sequence may be achieved with two airflow elements, one in each primary duct.

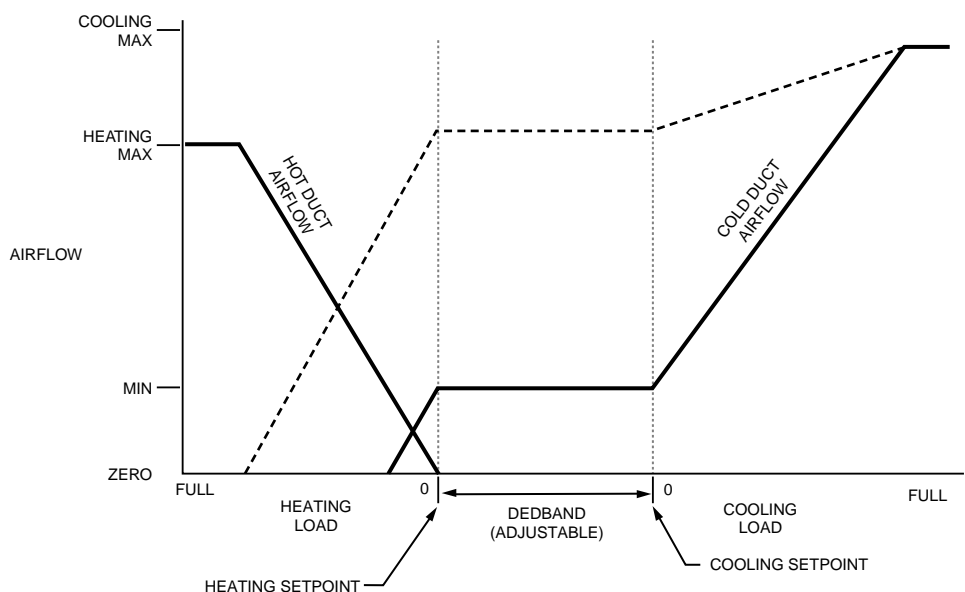
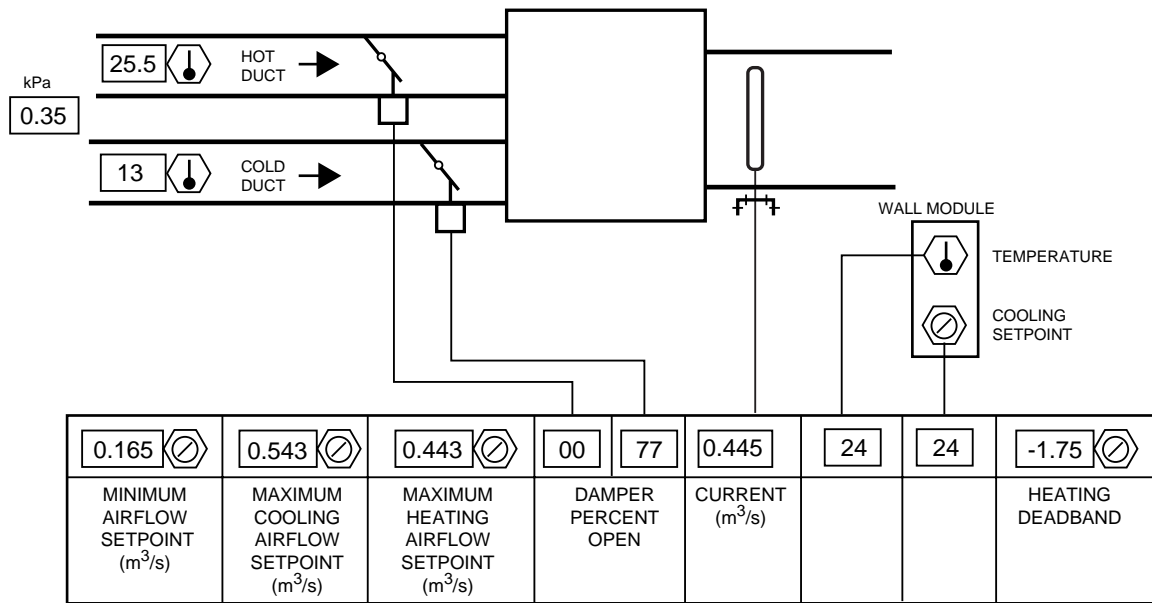

M15311

Fig. 10. Dual-Duct Pressure Independent VAV Air Terminal Unit.

The dotted line of Figure 10 shows a modification of this strategy where the constant volume requirement is relaxed a little to provide some VAV cooling control prior to going into the heating/mixing portion of control. This allows a dead band and a little VAV cooling control. This uses the same hardware (and cost) and allows an easily adjustable minimum airflow, up to the maximum. In this configuration, the room will operate at the heating setpoint most of the time and the lower the minimum airflow is set, the more time control will be in the deadband range or at the cooling setpoint. Rooms may have either high minimum airflow setpoints or low minimum airflow setpoints.

Dual Duct Pressure Independent Constant Volume ATU

Figure 11 shows a constant volume pressure independent dual duct ATU. Modulating the hot duct damper, up to a total flow not to exceed the maximum airflow setpoint maintains the room temperature. A constant total airflow is normally maintained by modulating the cold duct damper. With this configuration, there is no deadband and comfort is maintained by mixing hot and cold air at a constant total airflow. Hot and cold duct temperature load reset is very important in all dual duct systems to minimize energy waste.

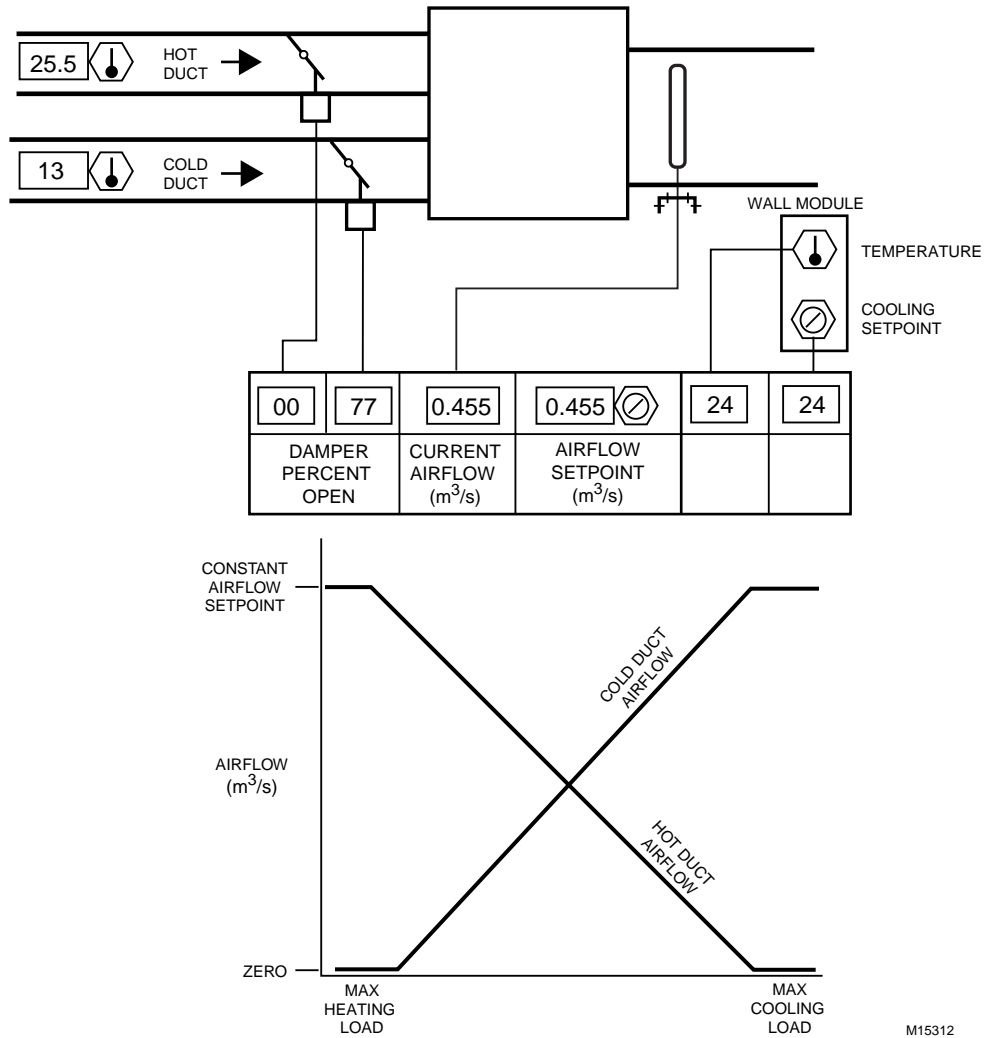

Fig. 11. Dual-Duct Constant Volume Air Terminal Unit.

UNITARY EQUIPMENT CONTROL

GENERAL

Unitary equipment includes natural convection units, radiant panels, unit heaters, unit ventilators, fan coil units, and heat pumps. Unitary equipment does not require a central fan. Depending on design, unitary equipment may perform one or all of the functions of HVAC—ventilation, filtration, heating, cooling, humidification, and distribution. Unitary equipment frequently requires a distribution system for steam or hot and/or chilled water. For information on distribution systems, refer to Chiller, Boiler, and Distribution System Control Applications section.

Control of unitary equipment varies with system design and may be electric, electronic, pneumatic, or digital. Typically, a room thermostat or sensor provides a signal to a controlled device to regulate the unit. The unit may use day/night temperature setpoints for operation at lower setpoints during unoccupied heating hours. If the unit has a fan, a time clock or time program may be used to turn the fan off at night and a night temperature controller may be used to control the temperature within night limits.

NATURAL CONVECTION UNITS

Natural convection units use steam or circulating hot water to route heat through a combination of radiation and natural draft convection units. They can supply total space heat or supplemental heat to the perimeter of a building to offset heat loss. The units are classified as follows:

- Radiator: A steel or cast iron unit through which hot water or steam circulates. Heating is by radiation and convection.
- Convector: A coil, finned tube, or electric heat element in an enclosure with openings at the top and bottom for convection circulation of air.
- Baseboard: A unit installed at the base of a wall. Hot water or steam circulates through a finned tube or a cast iron enclosure. Air circulates through the unit by convection.

Typically, a natural convection unit is controlled manually or by a room thermostat controlling a valve or electric heat coil. Figure 12 shows the control loops for individual room control. As space temperature falls below the thermostat setpoint, the valve opens and hot water or steam circulates through the unit. Natural convection transfers heat to warm the space and the thermostat resets the valve position as space temperature reaches setpoint. Depending on space size, the thermostat may control one valve or several valves.

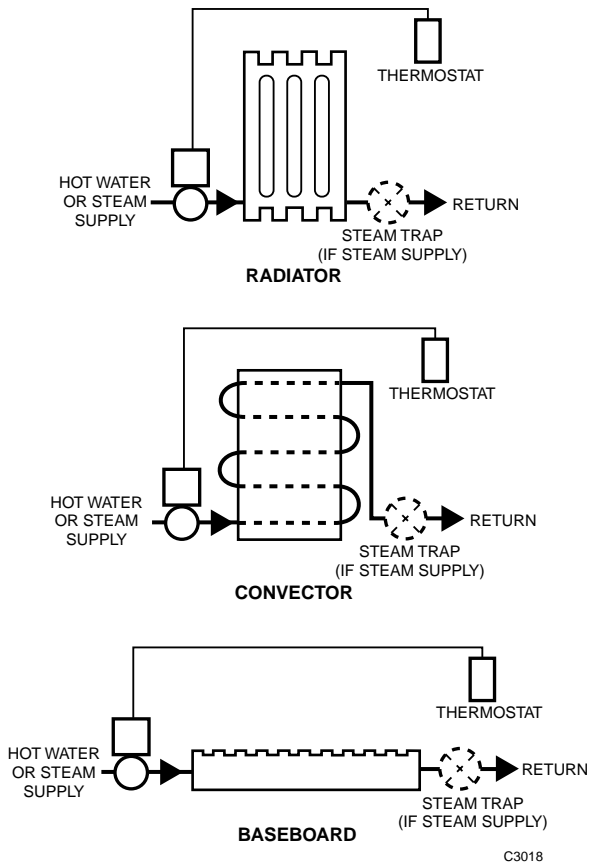

Fig. 12. Natural Convection Units.

Control of these units can be modulating or two-position. On long sections of steam-fed baseboard or finned-tube radiation, only two-position control should be used because modulating control causes steam to condense near the supply end of long units at light loads.

When used as supplemental heat for perimeter areas, natural convection units can be connected to central control systems. As heating requirements change with outdoor conditions and solar gain, the units can be reset or shut down by central control. In some applications, the convection units are slaved off a VAV box controller in sequence with or in lieu of reheat.

Electric resistance heating elements are also used in natural convection equipment. The thermostat controls electric current through the elements for heat convection. A modulating thermostat and a step controller or electronic modulating control can also control the heating element.

RADIANT PANELS

A radiant panel is a surface that transfers 50 per cent or more of its temperature to other surfaces by radiation. Radiant panels may be used for heating or cooling of individual spaces, or may be used in conjunction with central fan systems. The panel can be in a floor, wall, or ceiling, and the surface temperature can be maintained by electrical heating elements or by circulating water or steam.

Control for radiant panel heating or cooling can be difficult. Conventional space control with a thermostat may not be appropriate because it is difficult, if not impossible, to locate the thermostat to sense the radiant heat. Because radiant heat does not heat the air, the thermostat must either see the radiant heat or sense the space temperature change caused by the radiation warming the furniture and occupants in the space. The time lag in the second instance is too long for accurate control. Figure 13 shows a hot water radiant floor heating panel with an outdoor reset control system.

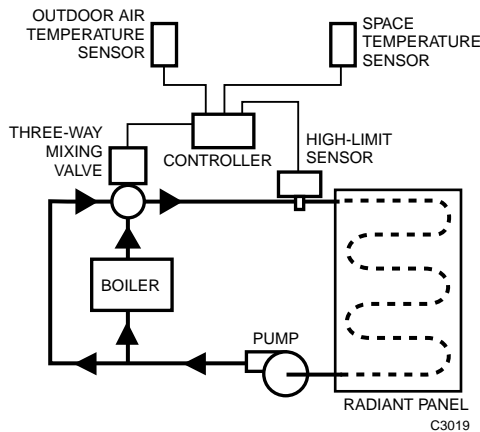

Fig. 13. Radiant Floor Heat System with Outdoor Reset Control.

The space sensor, reset from the outdoor temperature, controls the valve. As hot water circulates through the panel, heat radiates to warm objects in the space and space temperature rises. The space sensor senses the increase in space temperature and signals the controller to reposition the valve. The outdoor air sensor provides a reset schedule to raise the controller setpoint as the outdoor temperature decreases. To prevent tiles from softening and concrete from cracking, radiant floor panel surface temperatures should not exceed 29.5°C. Where hot water temperatures may exceed 29.5°C, the high-limit sensor resets circulating water temperature.

Wall panels and ceiling panels can be controlled directly by a room thermostat. Surface temperatures should not exceed 38°C for wall panels and 50 °C for ceiling panels. (The actual hot water temperature may be higher.)

Radiant heat panels that use electric resistance heating elements are controlled by a two-position thermostat. As the space temperature drops below the thermostat setpoint and differential, the thermostat closes a switch to allow current flow to heat the elements.

When a radiant panel is used for cooling, the temperature of the water circulating through the panel must be at least 0.5 kelvins above the dew point temperature of the space to prevent condensation on the panel.

A radiant panel may be used for both heating and cooling, as shown in Figure 14. A heating/cooling panel uses a four-pipe system regulated by two-way valves on both supply and return. A call for heat at the thermostat closes the chilled water supply and return ports and modulates hot water supply and return. A call for cooling closes the hot water supply and return ports and modulates chilled water supply and return.

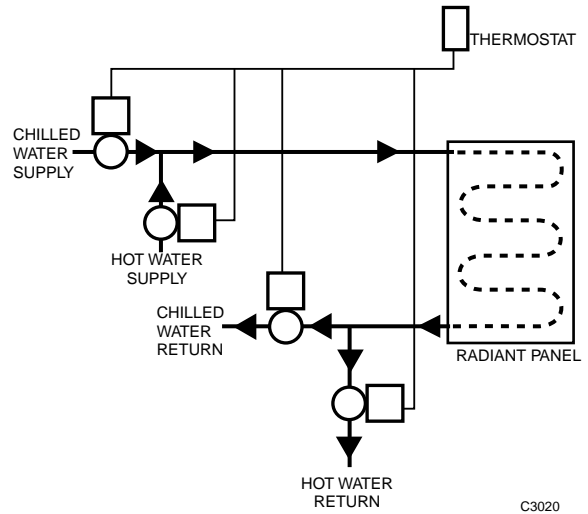

Fig. 14. Heating/Cooling Radiant Panel.

Constant-volume, constant-temperature central fan systems can be combined with radiant-panel heating or cooling to satisfy ventilation requirements. Occupancy schedules determine fan operation. Room thermostats control the radiant panels to maintain space temperature. Load anticipation is necessary because of the high thermal inertia of this system. In general, the thermostat setting should not be changed because of thermal lag and the possibility of overshoot. Thermal lag in some radiant floors can be several hours or more.

UNIT HEATERS

GENERAL

Unit heaters provide space heating for large open areas such as building entrances, garages, workshops, warehouses, and factories. Unit heaters are typically hung from the ceiling, although cabinet versions are available. A fan forces air across a coil containing hot water, steam, a warm-air heat exchanger, or electric resistance elements. Warm-air units may be gas or oil fired.

CONTROL

Control of unit heaters may be modulating but is usually two position. Low-limit control (sensing the water or condensate temperature) is usually provided for night or summer shutdown when the heating system is off, and prevents the fans from blowing cold air if the heating system fails.

Two-Position Control

Figure 15 shows two-position control of a steam or hot water unit. When space temperature falls below the thermostat setpoint, the thermostat starts the fan. The fan forces air across the coil to warm the space. When space temperature rises to the setpoint, the thermostat contacts open and the fan turns off. Low-limit controls are typically installed to prevent the fan from operating until there is heat in the coil.

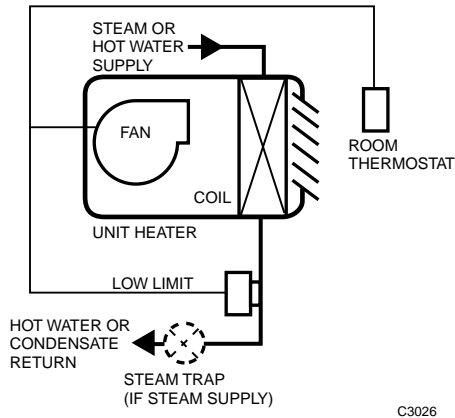

Fig. 15. Unit Heater Two-Position Control—Steam or Hot Water Heat.

Unit heaters with hot water or steam valves can also be operated from two-position thermostats. The thermostat can operate the valve and the fan or just the valve and let the low limit cycle the fan.

Figure 16 shows that control of an electric-heat unit heater is similar to steam or hot water two-position control except that the thermostat cycles the fan and the relay or contactor energizes the electric heating elements when the fan is running.

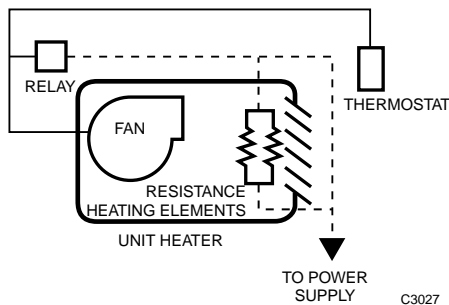

Fig. 16. Unit Heater Two-Position Control—Electric Heat.

Modulating Control

Modulating control (Fig. 17) throttles the heating medium in proportion to changes in space temperature. The fan operates continuously to prevent air stagnation. On a drop in temperature, the thermostat sends a signal to reposition the valve and the fan forces air across the coil to raise space temperature. When the valve is completely closed, the coil cools down and the low-limit control shuts off the fan. In some cases, the fan runs continuously or under time control without a low limit switch.

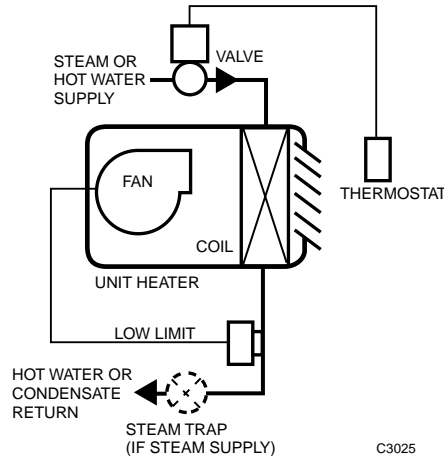

Fig. 17. Unit Heater with Modulating Control.

Pneumatic control of the valve and electric switching of the fan motor by the low-limit control are the most economical means of accomplishing modulating control. The low-limit control is usually a strap-on type mounted on the return pipe of either water or steam systems. In a steam system, the controller sensing element should be mounted between the unit and the steam trap.

DOWN-BLOW UNIT HEATER

The down-blow unit heater (Fig. 18) circulates warm air that normally stratifies near the ceiling. Control for this application requires two thermostats: one in the room (occupied area) and the other near the ceiling. The room thermostat controls the supply valve. The fan cycles with the valve. As the ceiling temperature rises above ceiling thermostat setpoint, the ceiling thermostat overrides the fan control and starts the fan. The fan runs until the ceiling thermostat is satisfied. This application recycles warm air and reduces the amount of heating medium circulated through the coil.

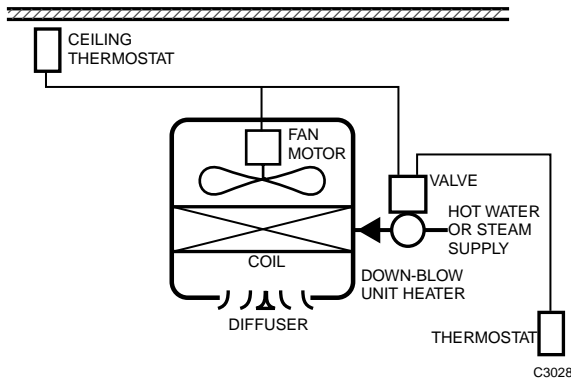

Fig. 18. Down-Blow Unit Heater.

GAS- OR OIL-FIRED UNIT HEATER

The gas-fired unit heater (Fig. 19) is used when a central hot water or steam system is not available. In a gas-fired unit heater, a gas burner heats a heat exchanger while a fan forces air across the exchanger to warm the space. The two-position control system comprises a thermostat, solenoid gas valve, safety cutout switch, pilot safety switch, and fan switch.

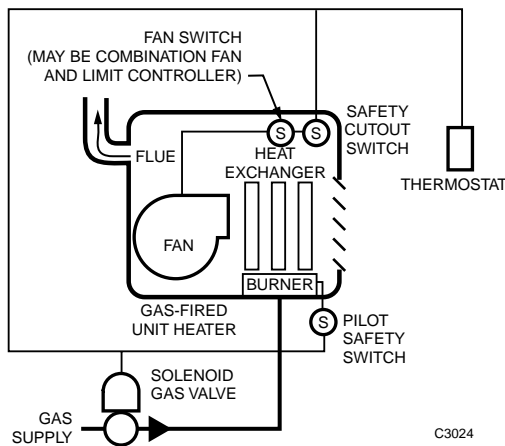

Fig. 19. Gas-Fired Unit Heater.

When space temperature falls below the thermostat setpoint, the thermostat contacts close to energize the gas valve. If the pilot safety switch indicates the pilot burner is lit, the gas valve energizes. The burner warms the heat exchanger and the fan switch turns on the fan. The burner operates until space temperature warms to setpoint. If unacceptably high temperatures occur in the heater (e.g., during fan failure), the safety cutout switch closes the solenoid gas valve. After the room thermostat shuts off the burner, the fan continues to run until the heat exchanger cools.

Some larger industrial gas-fired unit heaters have two stages: two-position (low fire) and modulating (to high fire). These units are controlled by room thermostats designed to sequence the two-position and modulating stages on a decrease in space temperature.

Oil-fired unit heaters operate similarly to gas-fired unit heaters and include safety controls designed for oil burners.

UNIT VENTILATORS

GENERAL

A unit ventilator consists of dampers, a filter, a fan, a heating and/or cooling coil, and the necessary controls (e.g., a valve and damper actuator). Unit ventilators use outdoor air, recirculated or return air from the space, or a mixture of both. Unit ventilators are designed for many capacities and are used in areas where occupancy density indicates a need for controlled ventilation (e.g., classrooms, conference rooms). A unit ventilator control system varies heating, ventilating, and cooling (if available) while the fan runs continuously.

Figure 20 shows a “blow-through” unit ventilator. Dampers at the bottom of the unit control the amounts of outdoor air and return air brought into the unit. The air passes through the filter section and enters the fan section, where the fan blows it across the coil.

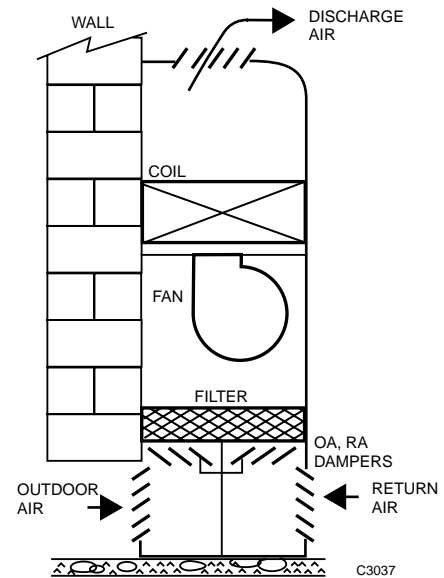

Fig. 20. Blow-Through Unit Ventilator.

In the “draw-through” unit ventilator (Fig. 21) the fan draws filtered outdoor and return air across the coil and blows the conditioned air into the space.

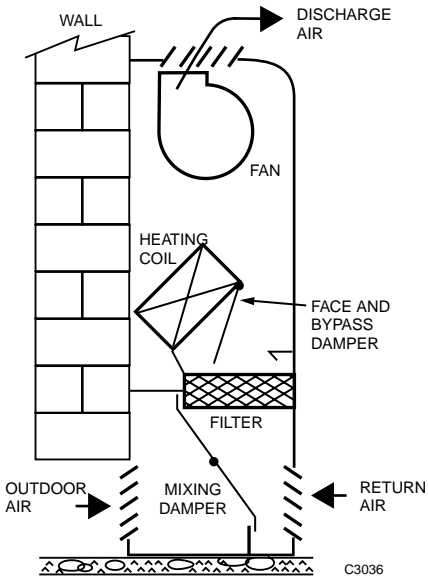

Fig. 21. Draw-Through Unit Ventilator.

Some unit ventilators use separate heating and cooling coils or a combination hot-water/chilled-water coil. Figure 22 shows a typical air conditioning unit ventilator with two separate coils. The heating medium may be hot water, steam, or electric resistance elements, and the cooling medium may be chilled water or DX refrigerant. If heating and cooling sources are both water, they are sometimes combined in a single coil by providing separate sections of the coil for each function. With DX cooling, the condensing unit may be an integral part of the unit ventilator or may be remotely located.

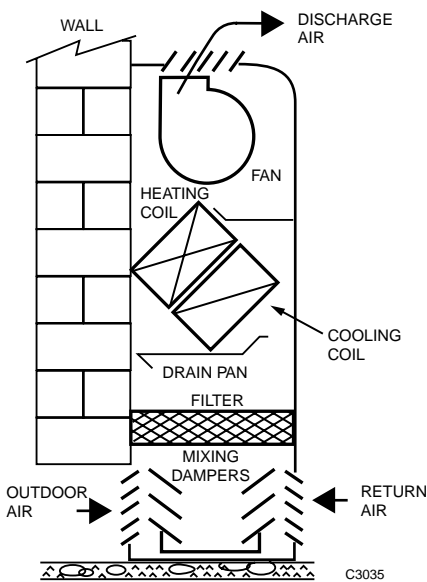

Fig. 22. Unit Ventilator with Separate Heating and Cooling Coils.

Face and bypass damper s are frequently found on unit ventilator s wherein the room controller modulates the damper s, and the coil valve closes after the face damper is closed.

CONTROL

Unit ventilator control regulates the amount of outdoor air introduced into a space and the amount of heating or cooling medium required to heat or cool the room. Day/night systems can lower the setpoint and cycle the fan during unoccupied hours to maintain minimum temperatures and save energy.

ASHRAE Control Cycles

ASHRAE classifies the control of unit ventilator s as follows:

- Standby/Warmup Stage (can be used with any of the following cycles)
- Cycle I—Fixed Maximum Percentage of Outdoor Air
- Cycle II—Fixed Minimum Percentage of Outdoor Air
- Cycle III—Variable Outdoor Air

These classes, defined around the 1950’s, simplified the specifications for unit ventilators, unit ventilator controls and sequences, and the factory mounting of control components. These cycle definitions are for heating only, although ASHRAE recognized that cooling coils may also be required. Cycles I, II, and III differ in the sequence of damper action in response to a rise in space temperature and in the amount of outdoor air admitted at various temperatures. ASHRAE control cycles may be implemented by pneumatic, electric, electronic, or digital control.

STANDBY/WARMUP STAGE

During cold room periods, all three cycles position the valves and dampers the same. Figure 23 shows the standby/warmup stage in which the unit ventilator fan is shut down (manually or by time clock). The outdoor air damper is closed, and the return air damper is full open. The heating coil valve is open. The coil acts as a convector as air circulates by convection across the coil. The room thermostat modulates the valve, closing the valve as space temperature rises above setpoint. The fan does not operate in the standby stage. During the warmup stage, the fan energizes and the unit recirculates space air for a rapid rise in space temperature. The thermostat signal operates the valve to control the heat.

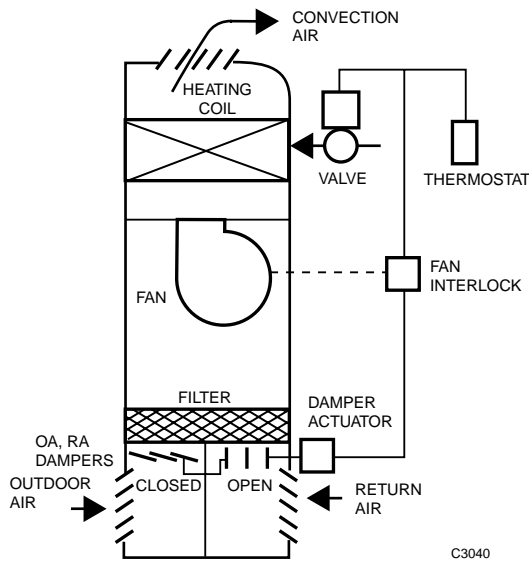

Fig. 23. Unit Ventilator in Standby/Warmup Stage.

CYCLE I—FIXED MAXIMUM PERCENTAGE OF OUTDOOR AIR

When the space is warmed to the low end of the thermostat range, Cycle I begins. As shown in Figure 24, control components are the room thermostat, heating coil valve, damper, and modulating low-limit controller. The outdoor air damper and heating coil valve operate in sequence in accordance with the demand of the thermostat. The heating valve is full open. As space temperature rises, the thermostat modulates the damper to its maximum open position. The fixed maximum position is normally 100 percent open. As space temperature continues to rise, and after the damper moves to its maximum position, the heating coil valve modulates closed. If a cooling coil is installed in the unit, the cooling coil valve opens as space temperature rises further. The low limit controller is necessary to prevent freezing conditions that occur when occupants lower the room control setpoint when it is below freezing outside, plus it prevents the discomfort that would result in discharging air into the room below 13 °C.

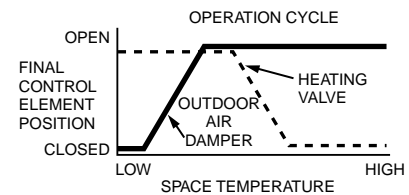
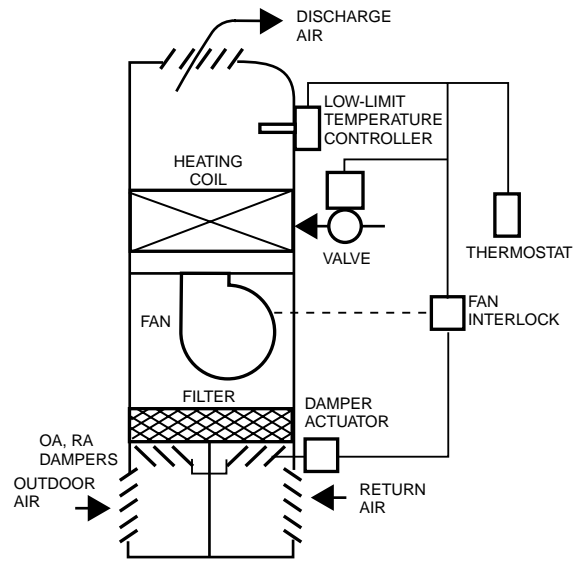

Fig. 24. Unit Ventilator Cycle I Control.

CYCLE II—FIXED MINIMUM PERCENTAGE OF OUTDOOR AIR

Cycle II control (Fig. 25) provides a fixed minimum percentage of outdoor air (usually 10 to 33 percent, adjustable from 0 to 100 percent).

At low space temperatures, the outdoor air damper is closed and the heating coil valve and face damper are full open. As space temperature rises, the outdoor air damper moves to its minimum position. On a further rise in space temperature, the face damper modulates closed, and on a further rise in space temperature, the coil valve closes. When the space temperature is at setpoint, the valve is full closed. As space temperature rises above setpoint, the outdoor and return air dampers modulate to 100 percent outdoor air at the top of the thermostat range. The low-limit controller can limit the closure of the coil valve, face damper, and the opening of the outdoor air damper to prevent the discharging air temperature from dropping below its setpoint.

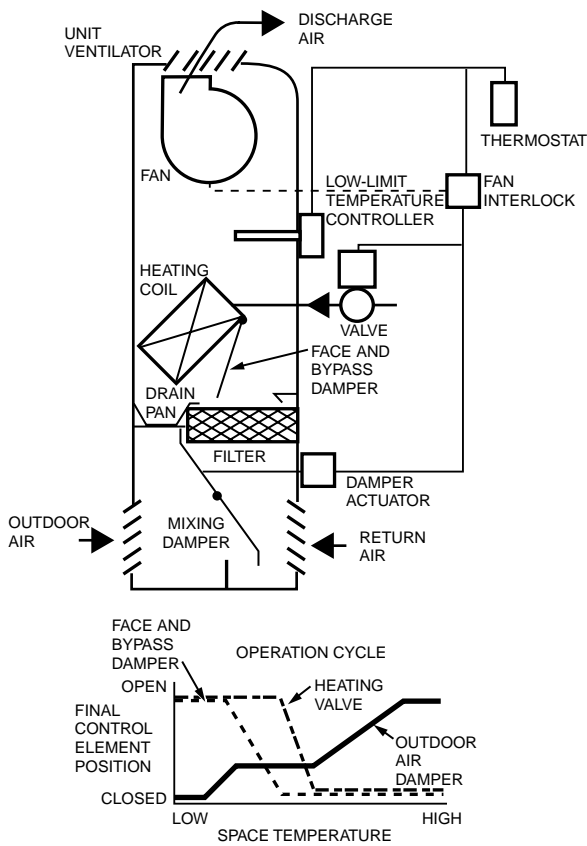

Fig. 25. Unit Ventilator Cycle II Control (Face and Bypass Model).

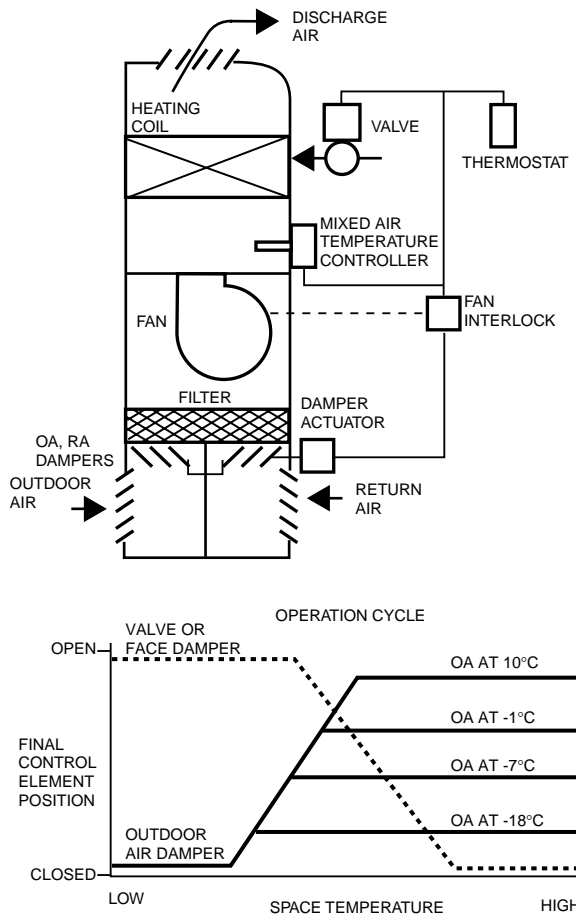

Fig. 26. Unit Ventilator Cycle III Control.

CYCLE III—VARIABLE OUTDOOR AIR

Cycle III control (Fig. 26) provides a variable percentage of outdoor air depending on the outdoor air temperature. This cycle is basically a reheat cycle where a constant cooling air temperature (usually 13 °C) is heated to maintain room temperature. According to ASHRAE's definition, there is no minimum or maximum OA damper position.

When space temperature is below the thermostat setpoint, the outdoor air damper is closed and the return air damper and coil valve (or face damper) are full open. As space temperature rises, the mixed air controller modulates the outdoor and return air dampers to maintain a mixed air temperature of 13 to 16 °C. On a further rise in space temperature, the valve or face damper modulates to ward closed.

Whenever the fan turns off, the fan interlock causes the outdoor and return air dampers to move to the 100 per cent return air position. The coil valve opens and the unit ventilator functions as a convector.

Unit ventilators with air conditioning can use any of the control cycles with a mechanical cooling stage. As space temperature rises, the room thermostat controls the unit ventilator cooling capacity through the regulation of the cooling valve or compressor.

Day/Night Setback Control

Unit ventilators can be operated at lower setpoints during unoccupied hours to save energy. Two commonly used day/night systems are individual room day/night control and zone day/night control. Pneumatic actuation is preferred for unit ventilator control because it operates smoothly and changes modes of operation through a simple pressure change.

Individual room day/night control uses a day/night room thermostat that operates at a higher day temperature setpoint and a lower night temperature setpoint when responding to a call for heat. During night operation, the outdoor air damper remains closed, the return air damper and coil valve remain open, and the fan cycles to maintain the lowered space temperature.

The room thermostat may provide a manual override that allows occupants to restore the unit ventilator to daytime setpoint before or after hours occupancy. Return to daytime operation is optional with the manual override function depending on the type of thermostat.

Zone day/night control requires one zone night thermostat for two or more unit ventilators that make up a zone. During night operation, the coil valve opens, the outdoor air damper closes, and the night thermostat cycles the fans to maintain the setpoint of the zone night thermostat. For daytime operation, a central switch deactivates the zone night thermostat and provides continuous fan operation.

Unit Ventilator Digital Control

Digital control offers several enhancements to unit ventilator control, including PID control, enhanced digital control, and graphic display.

Figure 27 is of a DDC ASHRAE Cycle III basic system. Unless the space temperature is below setpoint the fan discharge temperature is constant at 13°C. The space sensor modulates the HW valve for comfort control. Other than PI control and friendly display of values and setpoints, this figure is the standard cycle III.

Figure 28 utilizes the digital system capabilities to provide enhanced Cycle II operation.

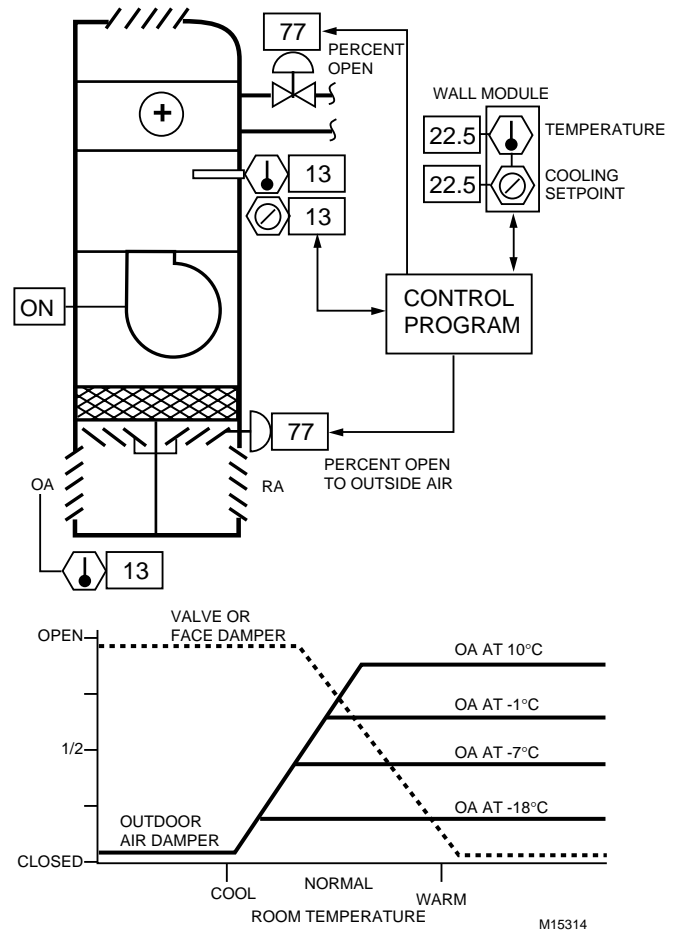
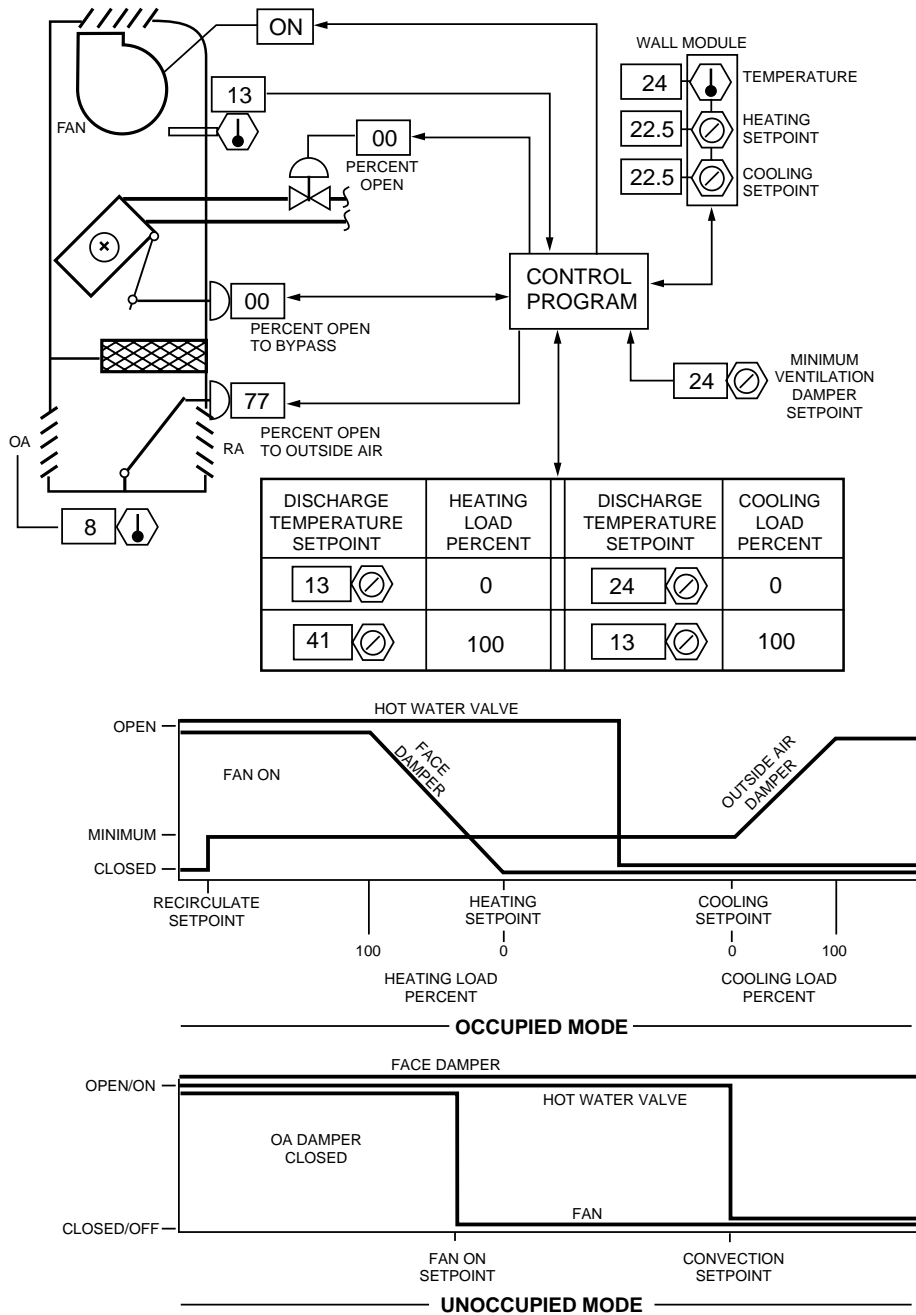

Fig. 27. Cycle III Digital Control



M15315

Fig. 28. Cycle II with Enhanced Digital Control.

On morning occupancy startup, the fan operates with the hot water valve open, the face damper open, and the O A damper closed; and as the room warms to a vent/recirculate setpoint, the O A damper opens to a minimum ventilation position. As the heating load drops, the face and bypass damper s modulate to maintain the room heating temperature setpoint. As the room temperature rises to a value midpoint between the heating and cooling setpoints, the heating valve closes. If the room temperature rises to the cooling setpoint, the O A damper modulates to maintain the cooling setpoint.

Although the discharge air sensor could be used as a low limit only, Figure 28 shows it as the primary controller reset from the demands of the room sensor.

In the unoccupied mode, the valve is controlled in a two-position manner to maintain an unoccupied convection heating room temperature setpoint. If the room temperature cannot be maintained by convection heating, the fan is cycled to maintain the unoccupied heating fan-on setpoint. The face damper is open and the O A damper is closed.

Figure 29 adds a chilled water coil to Figure 28.

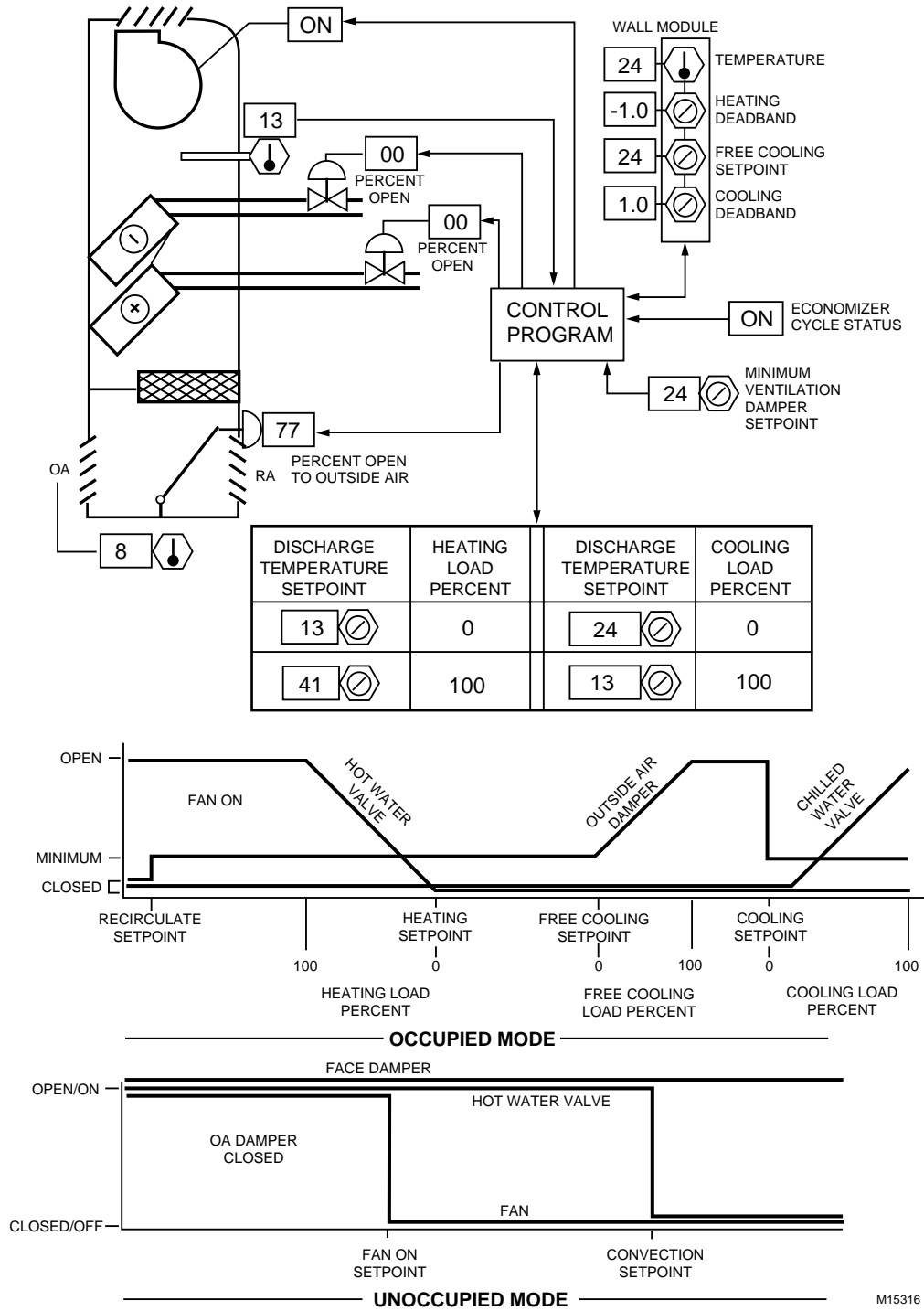

Fig. 29. Cycle II with Cooling and Enhanced Digital Control

Three room temperature setpoints are shown, free cooling, a heating deadband, and a mechanical cooling deadband. The free cooling setpoint may be manual on the wall module, or software (with software bounds). All unit ventilators are switched to the free cooling economizer mode of operation globally anytime the OA is suitable (see the Air Handling System Control Applications section). When the OA is unsuitable for free cooling assistance, and chilled water is available, the OA damper is returned to the minimum ventilation.

PRECAUTIONS AND CONDITIONS FOR SUCCESSFUL OPERATION

Unit ventilators require protection from blocked airflow, power failure, and coil freeze-up.

Blocked Airflow

Proper airflow is essential to satisfying space temperature and ventilation requirements. Objects located directly over the discharge air vents can inhibit or block airflow. Cleaning or replacing the filter as needed and cleaning dust and dirt from unit ventilator coils improves airflow through the unit ventilator.

Power Failure

Precautions for power and airflow failure must be specified when the automatic control system is designed. Pneumatic systems require an electric-pneumatic switch to exhaust the valve and damper actuator diaphragms on a power or airflow failure. The outdoor air damper closes and the return air damper and coil valve open. Electric, electronic, and digital control systems should be specified with spring-return actuators that close the outdoor air damper and open the return air damper on power failure.

Coil Freeze-Up

Causes of coil freeze-up include central system circulating pump or boiler failure, outdoor air damper or control valve malfunction, and uneven temperature distribution. A low-limit controller can help prevent coil freeze-up by overriding other control system components to close the outdoor air damper and open the return air damper and coil valve. Effective freeze-up protection depends on available heat in the system and flow through the coils.

Coils can also freeze when low-temperature outdoor air leaks through defective dampers. Frequent inspection of dampers should be made to detect bent and broken damper linkages, warped damper blades, and defective or missing blade seals that can contribute to coil freeze-up.

Low temperature switches to stop the fan and close the OA damper should be provided where freezing OA conditions are likely. With digital systems, during unoccupied periods, the low temperature switch may start the fan and the recirculating pump.

FAN COIL UNITS

GENERAL

Fan coil units are similar to unit ventilators except that fan coil units do not have dampers and typically do not have an outdoor air intake. They may also be configured for installation above a ceiling with ceiling or wall mounted discharge and return air grills. Fan coil units provide heating and/or cooling for single-zone areas such as apartments, offices, and individual hotel or hospital rooms. Figure 30 shows a typical fan coil unit comprising a finned-tube coil, a fan section, and a filter. The fan circulates air from the space across the coil. The coil may use steam or hot water from a central system or electric resistance elements to satisfy heating requirements. Chilled water or DX coils can be used for cooling. Units used for cooling only or for both heating and cooling have a built-in condensate drain pan to collect and drain condensate on the cooling cycle.

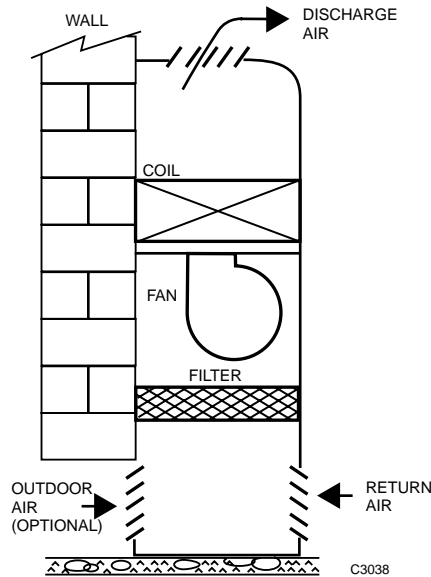

Fig. 30. Fan Coil Unit.

Fan coil units are classified as two-pipe heating, two-pipe cooling, two-pipe heating/cooling, or four-pipe heating/cooling. Control for a fan coil unit typically comprises a room or return air thermostat for individual room control. The thermostat regulates a valve while a fan moves air through the unit and across the coil. The fan runs continuously, is scheduled, or is cycled on and off by the thermostat. The fan is often three speed with a local three-speed switch. Some applications control only the fan operation and allow the conditioning medium to flow continuously in the coil. Fan coil units can use pneumatic, electric, electronic, or digital control.

TWO-PIPE HEATING/COOLING

The flow of medium through a fan coil unit can be controlled in two ways. One method uses a two-way valve to control the flow of steam or hot or chilled water. The second method, shown in Figure 31, uses a three-way valve to control hot or chilled water flow.

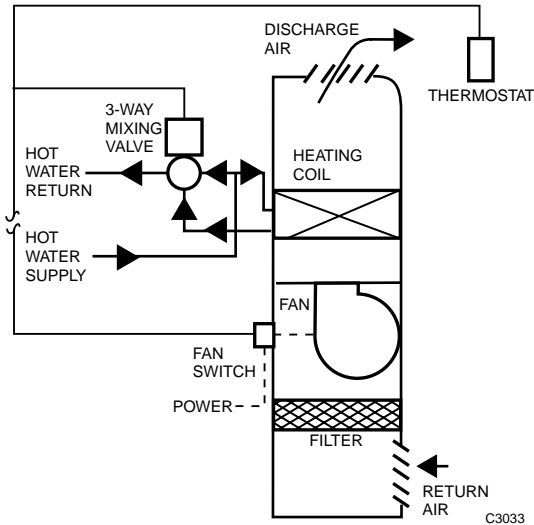

Fig. 31. Two-Pipe Heating Fan Coil Unit Using Three-Way Mixing Valve.

The three-way valve provides constant flow in the supply and return lines and minimizes pressure fluctuations at the valve. A modulating thermostat controls the three-way valve to regulate water flow through the coil. In a heating application, when the thermostat senses space temperature below the thermostat setpoint, the valve is positioned to allow full flow through the coil. As space temperature rises, the thermostat control signal modulates the valve to decrease the amount of flow through the coil and increase the bypass flow around the coil. At the upper end of the thermostat throttling range, the valve is in the coil bypass position, eliminating flow through the coil. The fan runs continuously or is stopped as space temperature rises above setpoint. Cooling-only systems operate in a similar way.

TWO-PIPE HEATING/COOLING, SINGLE COIL

Figure 32 shows a two-pipe fan coil application that uses a single coil for heating and cooling with seasonal changeover. Control for this application requires a heating/cooling room thermostat that reverses its action from a remote heating/cooling changeover signal. One method of automatic changeover is to install a pipe-mounted sensor that switches thermostat action when it senses a change in supply medium between hot and chilled water. Because it cannot offer simultaneous heating and cooling capability, this system can cause problems during intermediate seasons when hot water is in the system and cooling is needed, or vice versa.

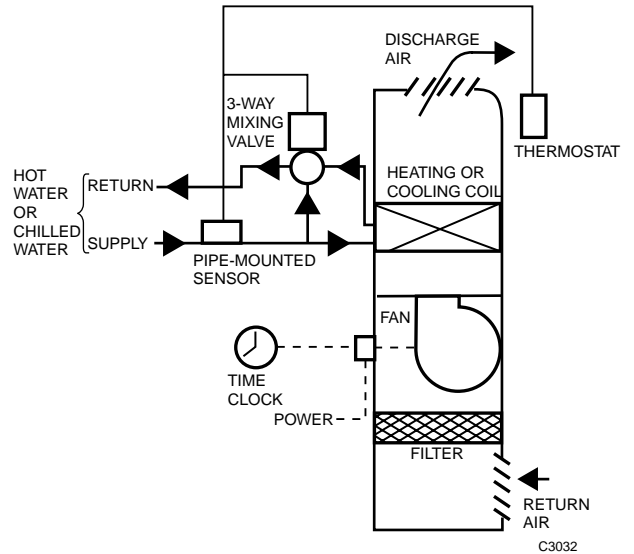

Fig. 32. Two-Pipe Heating/Cooling Fan Coil Unit.

The room thermostat opens the coil valve on a fall in space temperature during the heating cycle. In the cooling cycle, chilled water in the pipes causes the pipe-mounted sensor to reverse the thermostat action and the thermostat opens the valve as space temperature rises. The fan can be operated from a local switch or a central time clock.

The surface area of the coil is large to accommodate cooling requirements. Therefore, when a single coil is used for both heating and cooling, the hot water supply temperature should be lower. Typical hot water supply temperatures range between 32 and 60 °C.

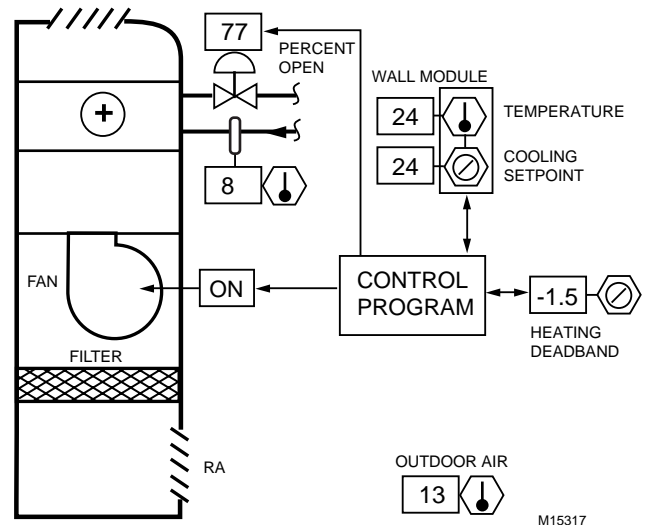

Fig. 33. Digitally Controlled Two-Pipe Heating/Cooling Fan Coil Unit.

Digital Control of the two pipe heating/cooling fan coil unit should above could be as Figure 33. The fans could be batch scheduled via one or more optimum start programs. Wall modules could have a cooling setpoint knob (with software bounds) and a heating deadband. The entering water temperature (from a plant sensor) and the outside air temperature are shown for operator information. The heating/cooling plant could be controlled similarly to that described in the paragraph Hot Water Plant Considerations.

The four-pipe heating/cooling fan coil unit control would be identical except the valves would be sequenced through the deadband.

FOUR-PIPE HEATING/COOLING, SPLIT COIL

Year-round heating and cooling is possible at each unit with a four-pipe heating/cooling, split coil application (Fig. 34). A fan coil unit in one zone can cool while a unit in another zone heats. The control system comprises a room thermostat connected to two valves, one controlling hot water flow and the other controlling chilled water flow. Valves can be two-way or three-way.

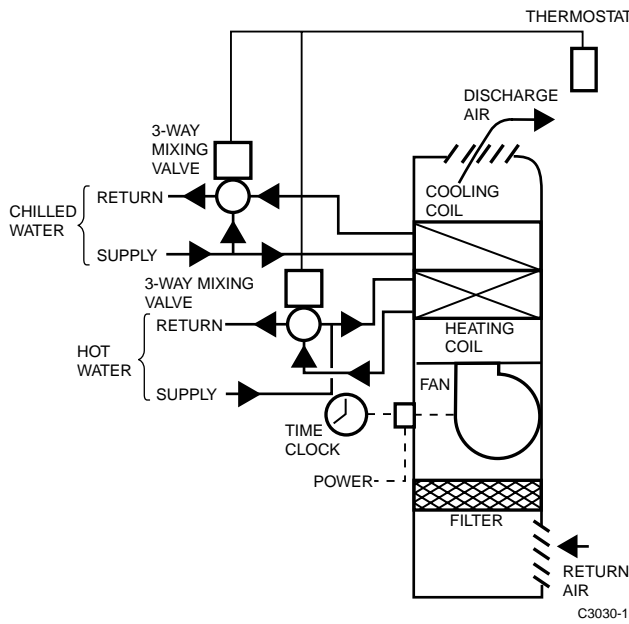

Fig. 34. Four-Pipe Heating/Cooling Fan Coil Unit with a Split Coil.

When space temperature is below the thermostat setpoint, the hot water supply valve modulates open and hot water flows through the heating coil. As space temperature increases, the hot water valve modulates closed. As space temperature rises above setpoint, the thermostat signal starts to open the chilled water valve. The room thermostat throttling range and valve actuator movement should be selected to provide a "deadband" between heating and cooling so that both valves are closed when space temperature is satisfied. The fan can be operated by a local fan switch or a central time clock.

FOUR-PIPE HEATING/COOLING, SINGLE COIL

Figure 35 shows the single-coil method for four-pipe heating/cooling. A thermostat controls two three-way valves to regulate the flow of chilled or hot water into a single coil.

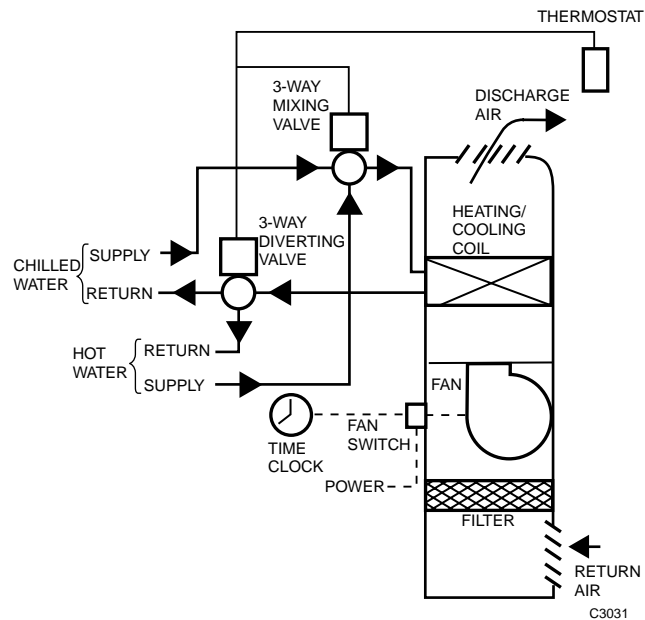

Fig. 35. Four-Pipe Heating/Cooling Fan Coil Unit.

This system requires special three-way sequencing valves that shut off all flow at the middle of the thermostat throttling range. On a fall in space temperature, with the chilled water supply and return ports close, the hot water return port opens 100 per cent, and the supply valve hot water port modulates the hot water flow to maintain space temperature. As space temperature rises, the hot water supply and return ports close and flow through the coil is stopped. When space temperature rises above the thermostat setpoint, the chilled water return port opens to 100 per cent flow and the supply port modulates chilled water flow through the coil to maintain the space temperature. Both the chilled water and hot water supply ports are closed in a deadband between heating and cooling operations. The control is similar to having sequenced modulating two-way valves on the HW and CW supplies and sequenced two-position two-way valves on the returns. The fan can be operated by a local fan switch or a central time clock.

HEAT PUMPS

GENERAL

A heat pump is a refrigeration system that provides both heating and cooling within the same unit. In the heating mode, the pump delivers heat from a heat source to the conditioned space. In the cooling mode, the pump removes heat from a space and transfers it to a heat sink. Heat pumps use standard refrigeration components (compressor, expansion valve, evaporator, and condenser) and a reversing valve to reverse refrigerant flow through the coils. A refrigerant reversing valve switches at changeover to convert the condenser to an evaporator and vice versa.

Figure 36 shows heat pump cycles. In the cooling cycle, refrigerant flow uses the outdoor heat exchanger coil as the condenser to reject heat from the space, and the indoor coil as the evaporator. In the heating cycle, flow of air and refrigerant is reversed making the outdoor coil the source of heat. The indoor coil becomes the condenser and provides heat for the space. When outdoor air temperature is too cold to provide enough heat transfer, electric resistance heating elements can be used to provide supplemental heat. An alternative method is to reverse indoor and outdoor air flow across the coils and eliminate the reversing valve.

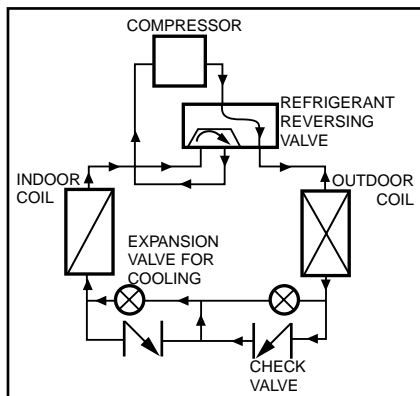

COOLING CYCLE

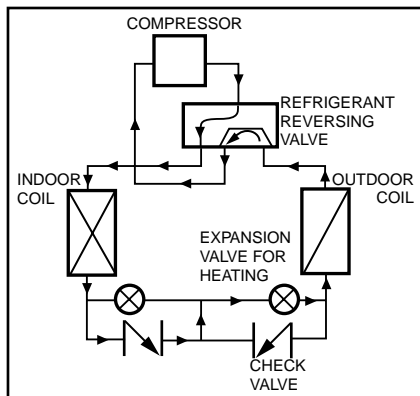

HEATING CYCLE

C3021

Fig. 36. Refrigerant Flow in Heat Pump Cooling and Heating Cycles.

Heat pumps are typically classified by the heat source at the “outdoor” coil. The common air-to-air heat pump uses outdoor air as its heat source during the heating cycle. A water-to-air heat pump uses water as the heat source during the heating cycle. The water supply may be a well or a lake. In the cooling mode, the outdoor coil rejects heat and the air or water becomes the heat sink.

In commercial applications, a closed-loop or recirculating water supply may serve multiple units (Fig. 37). This system relies on load diversification. Some units may be cooling while others operate in the heating cycle. In this case, the water loop is a source to heating units and a sink to cooling units, transferring heat from one to the other. Water-loop temperatures are maintained between 21°C and 32°C to provide an adequate heat source or heat sink. A central boiler together with a chiller and/or cooling tower water temperature in the loop during peak heating and cooling periods. For a discussion of central regulation and control of water pump hydraulic loops, refer to Chiller, Boiler, and Distribution System Control Applications section.

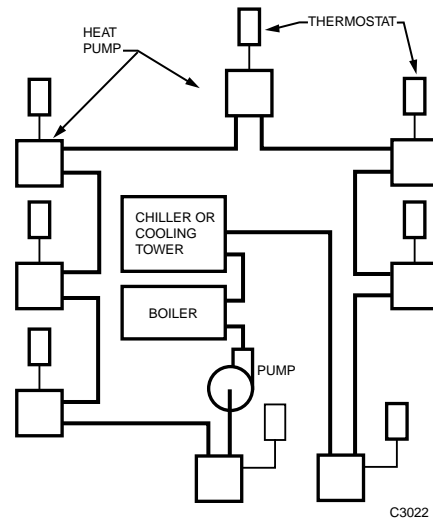

C3022

Fig. 37. Heat Pump Closed-Loop System.

OPERATION

Small and medium-sized heat pumps usually heat and cool indoor air and are controlled from a space thermostat. Large heat pumps usually provide warm and chilled water and are controlled by a chilled water temperature control.

Space thermostats are two-position and usually multistage. They typically provide automatic changeover, switching the heat pump between heating and cooling as required to maintain space temperature. The first stage of the thermostat cycles the compressor. If the system is in a heating mode, additional thermostat heating stages will bring on supplementary resistance heat if the heat pump cannot meet the load. In the cooling mode, there is only one stage that cycles the compressor. If desired, changeover between heating and cooling can be manual rather than automatic. The thermostat can have separate heating and cooling settings or a single setting with a fixed deadband between heating and cooling.

In some heat pumps, a minimum off timer prevents a compressor restart for three to five minutes. After shutdown, heat pump operation must not resume until pressures equalize between the suction and discharge sides of the compressor. Short cycling the heat pump may result in compressor damage.

A two-stage, high-speed compressor can provide capacity control for maximum heat pump efficiency. The room thermostat controls the individual compressor stages. The thermostat second stage controls the auxiliary heat (for air-source heat pumps) and compressor stage two. When the outdoor thermostat closes as outdoor temperature falls to its setpoint, the auxiliary heat energizes with the compressor (Fig. 38).

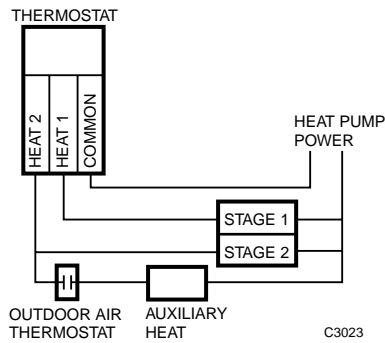

Fig. 38. Heat Pump Staging.

Defrost cycling is typically used when outdoor temperatures are below 7 °C, because the outdoor coil may operate below freezing and frost can form on the coil when the unit is in the heating mode. Frost inhibits airflow through the heat pump and degrades unit performance. To remove the frost, the heat pump momentarily switches to the cooling mode. Hot gas from the compressor is directed to the outdoor coil, and the frost melts. Typically the unit cycles every 90 minutes for four to eight minutes to defrost. Instead of time-initiated defrost, some models use demand defrost, which cycles to the cooling mode by measuring changes in the airflow across the outdoor coil.

CONTROL LOOPS

Heat pumps can use a variety of methods to change between cooling and heating, including a two-position room thermostat and manual changeover.

Assuming automatic changeover between heating and cooling, on a rise in space temperature, a two-position room thermostat senses the temperature rise and cycles the heat pump in the cooling mode. When space temperature falls below the deadband, the first stage of heating cycles the compressor in the heating mode. A further drop in space temperature brings on additional thermostat heating stages to turn on supplemental electric resistance heaters.

In some heat pumps, the changeover valve cycles with the compressor in either the heating or cooling mode. In others, the changeover valve remains in the heating or cooling position as long as space temperature is in the appropriate range.

Where a central water plant provides heating/cooling source water for the heat pumps, water control is often provided to conserve water when the heat pump cycles off and when the water temperature is excessive for the load. Valves may be refrigerant pressure (may be furnished with the heat pump) or temperature controlled. Temperature controlled valves must close when the compressor is off, but must have a minimum open position anytime the heat pump operates in order to keep water flow across the water sensor.

Heat pump system controls must be carefully coordinated with the heat pump manufacturer and the water plant system (on air-to-water heat pumps).

INDIVIDUAL ROOM CONTROL AUTOMATION

On automated jobs with a graphic BMS, ATUs are usually shown on a floor plan similar to Figure 39.

The Figure 39 example shows a graphic of the southern half of a floor with 30 VAV boxes and their associated space temperatures. Selecting any VAV box would produce a graphic of that box, similar to those previously shown in this section, and all specified data such as space temperature setpoints, minimum and maximum airflow setpoints, etc.

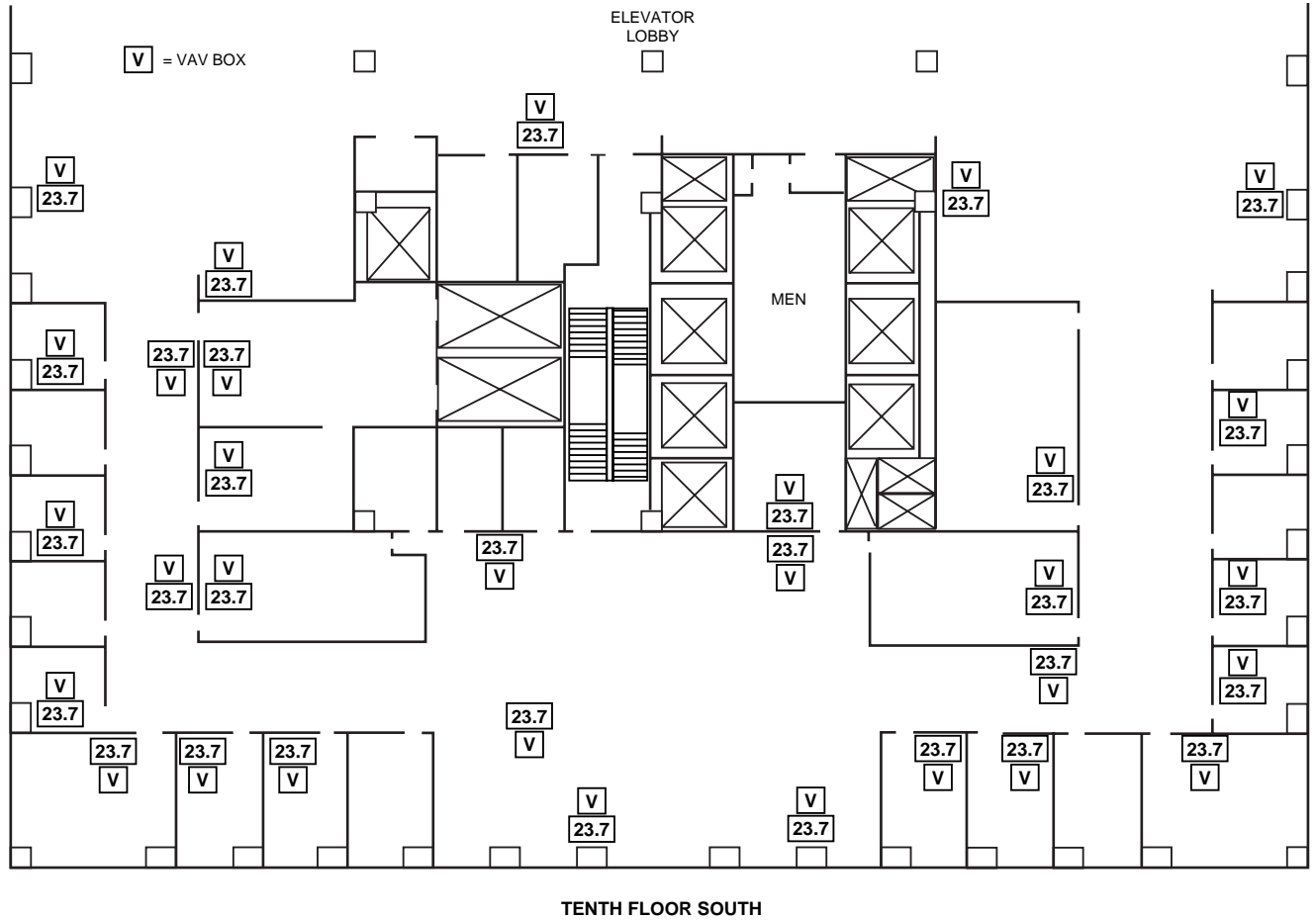

M10532

Fig. 39. ATU System Floor Plan Graphic

HOT WATER PLANT CONSIDERATIONS

See Chiller, Boiler, and Distribution System Control Applications section for additional information on hot water system control.

Because unit ventilators have large OA dampers in close proximity to the water coils, the hot water pump should run anytime the OA temperature is less than freezing, independent of hot water temperature.

Unit ventilator and fan coil unit hot water temperatures should be reset based upon the OA temperature to match the hot water temperature to the load. This allows much smoother control, and keeps adequate water velocities in the hot water coils if modulating valves are used. Dual schedules are recommended with significantly warmer water provided during unoccupied

periods to aid in the convection and warm-up efforts. A triple water temperature schedule may be considered where the convection mode has a higher water temperature than warm-up or occupied modes. The setpoint shift between modes should be ramped over a 20 to 30 minute duration.

The hot water pump should also run during unoccupied periods on a drop in room temperature to about 16 °C. In this mode the coils will act as a radiator and add heat to the building perimeter without running the unit ventilator fans.

Unit Ventilators and fan coil units and their associated heating and cooling plants should be started by a global optimum start program with the OA damper closed until occupancy time.

ENGINEERING INFORMATION

Valve Selection and Sizing

ENGINEERING MANUAL OF AUTOMATIC CONTROL

CONTENTS

Introduction	428
Definitions	428
Valve Components	428
Valve Flow Characteristics	428
Valve Flow Terms	429
Valve Ratings	429
Valve Types	430
Valve Material and Media	431
Valve Selection	432
Globe Valve	433
Ball Valve	433
Butterfly Valve	433
Two-Way Valve	434
Quick-Opening Valve	434
Linear Valve	434
Equal Percentage Valve	435
Three-Way Valves	436
Mixing Valve	436
Diverting Valve	436
Valve Sizing	437
Water Valves	437
Quantity of Water	438
Water Valve Pressure Drop	438
Water Valve Sizing Examples	439
Steam Valves	441
Quantity of Steam	442
Steam Valve Pressure Drop	442
Proportional Applications	442
Two-Position Applications	442
Steam Valve Sizing Examples	443

INTRODUCTION

This section provides information on valve selection and sizing. Valves must be selected for ability to meet temperature, pressure, flow control characteristic, and piping connection requirements of the hydronic system. Valve sizing is critical to

ensure support for heating and cooling loads with adequate valve capacity, yet able to control system flow to provide stable building conditions efficiently.

DEFINITIONS

VALVE COMPONENTS

Actuator: The part of an automatic control valve that moves the stem based on an electric, electronic, or pneumatic signal from a controller. The actuator and valve can be two separate devices or together they can be one device.

Body: The valve casting through which the controlled fluid flows (Fig. 1).

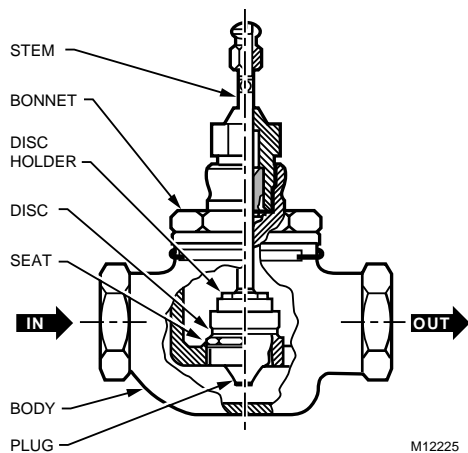

Fig. 1. Globe Valve Components.

Bonnet: The part that screws to the top of the valve body and contains the packing that seals and guides the valve stem.

Disc: The part of the valve assembly that contacts the valve seat to close off flow of the controlled fluid. Some valve assemblies are built so the disc is replaceable. Replaceable discs are usually made of a composition material softer than metal.

Plug: The part that varies the opening for the fluid to flow through the valve body. The following describes the three most common types of plugs:

- A contoured plug has a shaped end that is usually end-guided at the top or bottom (or both) of the valve body. The shaped end controls fluid flow through the valve with respect to stem travel.

- A V-port plug has a cylinder, called a skirt, that rides up and down in the valve seat ring. The skirt guides the plug and varies the flow area with respect to stem travel via its shaped openings.
- A quick-opening plug is flat and is either end-guided or guided by wings riding in the valve seat ring. The flat plug provides maximum flow soon after it lifts from the valve seat.

Port: The opening in the valve seat.

Seat: The stationary part of the valve body that has a raised lip to contact the valve disc when closing off flow of the controlled fluid.

Stem: The shaft that runs through the valve bonnet and connects an actuator to the valve plug.

Trim: All parts of the valve that contact the controlled fluid. Trim includes the stem, packing, plug, disc, and seat; it does not include the valve body.

VALVE FLOW CHARACTERISTICS

Direction of flow: The correct flow of the controlled fluid through the valve is usually indicated on the valve body. If the fluid flow through the valve is incorrect, the disc can slam into the seat as it approaches the closed position. The result is poor control, excessive valve wear, and noisy operation. In addition, the actuator must work harder to reopen the closed valve since it must overcome the pressure exerted by the fluid on top of the disc rather than have the fluid assist in opening the valve by exerting pressure under the disc.

Equal percentage: A valve which changes flow by an equal percentage (regardless of flow rate) for similar movements in stem travel (at any point in the flow range).

Linear: A valve which provides a flow-to-lift relationship that is directly proportional. It provides equal flow changes for equal lift changes, regardless of percentage of valve opening.

Quick-opening: A valve which provides maximum possible flow as soon as the stem lifts the disc from the valve seat.

Valve flow characteristic: The relationship between the stem travel of a valve, expressed in percent of travel, and the fluid flow through the valve, expressed in percent of full flow.

VALVE FLOW TERMS

Rangeability: The ratio of maximum flow to minimum controllable flow. Approximate rangeability ratios are 50 to 1 for V-port globe valves and 30 to 1 for contoured plug valves.

EXAMPLE:

A valve with a total flow capacity of 10 L/s full open and a rangeability of 30 to 1, can accurately control flow accurately as low as 0.3 L/s.

Tight shut-off/close-off: A valve condition in which virtually no leakage of the controlled fluid occurs in the closed position. Generally, only single-seated valves provide tight shut-off. Double-seated valves typically have a one to three percent leakage in the closed position.

Turndown: The ratio of maximum flow to minimum controllable flow of a valve installed in a system. Turndown is equal to or less than rangeability.

EXAMPLE:

For the valve in the rangeability example, if the system requires a 6.6 L/s maximum flow through the valve and since the minimum accurately controllable flow is 0.3 L/s, the turndown is 22.

VALVE RATINGS

Flow coefficient (capacity index): Used to state the flow capacity of a control valve for specified conditions. Currently, in the control valve industry, one of three flow coefficients British A_v , North American K_v , or United States C_v is used depending upon the location and system of units. The flow coefficients have the following relationships:

$$\begin{aligned} A_v &= 0.0000278 K_v \\ A_v &= 0.0000240 C_v \\ K_v &= 0.865 C_v \end{aligned}$$

The flow coefficient A_v is in cubic meters per second and can be determined from the formula:

$$A_v = Q \sqrt{\frac{\rho}{\Delta P}}$$

Where:

$$\begin{aligned} Q &= \text{volumetric flow in cubic meters per second.} \\ \rho &= \text{fluid density in kilograms per cubic meter.} \\ \Delta p &= \text{static pressure loss across the valve in pascals.} \end{aligned}$$

The flow coefficient K_v is water flow in cubic meters per hour with a static pressure loss across the valve of 10^5 pascals (1 bar) within the temperature range of 5 to 40°C and can be determined from the formula:

$$K_v = Q \sqrt{\frac{\Delta p K_v}{\Delta P} \cdot \frac{\rho}{\rho_w}}$$

Where:

$$\begin{aligned} Q &= \text{volumetric flow in cubic meters per hour.} \\ \rho &= \text{fluid density in kilograms per cubic meter.} \\ \rho_w &= \text{density of water in kilograms per cubic meter.} \\ \Delta p_{K_v} &= \text{static pressure loss of } 10^5 \text{ pascals.} \\ \Delta p &= \text{static pressure loss across the valve in pascals.} \end{aligned}$$

The flow coefficient C_v is water flow in gallons per minute with a pressure loss across the valve of one pound per square inch within the temperature range of 40 to 100°F and can be determined for other conditions from the formula:

$$C_v = Q \sqrt{\frac{1}{\Delta P} \cdot \frac{\rho}{\rho_w}}$$

Where:

$$\begin{aligned} Q &= \text{volumetric flow in US gallons per minute.} \\ \rho &= \text{fluid density in pounds per cubic foot.} \\ \rho_w &= \text{density of water in pounds per cubic foot within the temperature range of } 40 \text{ to } 100^\circ\text{F.} \\ \Delta p &= \text{static pressure loss across the valve in pounds per square inch.} \end{aligned}$$

Close-off rating: The maximum pressure drop that a valve can withstand without leakage while in the full closed position. The close-off rating is a function of actuator power to hold the valve closed against pressure drop, but structural parts such as the stem can be the limiting factor.

EXAMPLE:

A valve with a close-off rating of 70 kPa could have 270 kPa upstream pressure and 200 kPa downstream pressure. Note that in applications where failure of the valve to close is hazardous, the maximum upstream pressure must not exceed the valve close-off rating, regardless of the downstream pressure.

VALVE SELECTION AND SIZING

The valve close-off rating is independent of the actual valve body rating. See definition of BODY RATING (ACTUAL) in this section.

Close-off rating of three-way valves: The maximum pressure difference between either of the two inlet ports and the outlet port for mixing valves, or the pressure difference between the inlet port and either of the two outlet ports for diverting valves.

Critical pressure drop: See Pressure drop (critical).

Pressure drop: The difference in upstream and downstream pressures of the fluid flowing through the valve.

Pressure drop (critical): The flow of a gaseous controlled fluid through the valve increases as the pressure drop increases until reaching a critical point. This is the critical pressure drop.

Any increase in pressure drop beyond the critical pressure drop is dissipated as noise and cavitation rather than increasing flow. The noise and cavitation can destroy the valve and adjacent piping components.

Body rating (nominal): The theoretical pressure rating, expressed in kPa, of the valve body exclusive of packing, disc, etc. The nominal rating is often cast on the valve body and provides a way to classify the valve by pressure. A valve of specified body material and nominal body rating often has characteristics such as pressure-temperature ratings, wall thickness, and end connections which are determined by a society such as ANSI (American National Standards Institute). Figure 2 shows ANSI pressure-temperature ratings for valves. Note that the nominal body rating is not the same as the actual body rating.

Body rating (actual): The correlation between safe, permissible flowing fluid pressure and flowing fluid temperature of the valve body (exclusive of the packing, disc, etc.). The nominal valve body rating is the permissible pressure at a specific temperature.

EXAMPLE:

A cast-iron, screwed-end valve with a nominal rating of 850 kPa could have an actual rating of 850 kPa at 180°C and 1200 kPa at 65°C.

Maximum pressure and temperature: The maximum pressure and temperature limitations of fluid flow that a valve can withstand. These ratings may be due to valve packing, body, or disc material or actuator limitations. The actual valve body ratings are exclusively for the valve body and the maximum pressure and temperature ratings are for the complete valve (body and trim). Note that the maximum pressure and temperature ratings may be less than the actual valve body ratings.

EXAMPLE:

The body of a valve, exclusive of packing, disc, etc., has a pressure and temperature rating of 850 kPa at 180°C. If the valve contains a composition disc that can withstand a temperature of only 115°C, then the temperature limit of the disc becomes the maximum temperature rating for the valve.

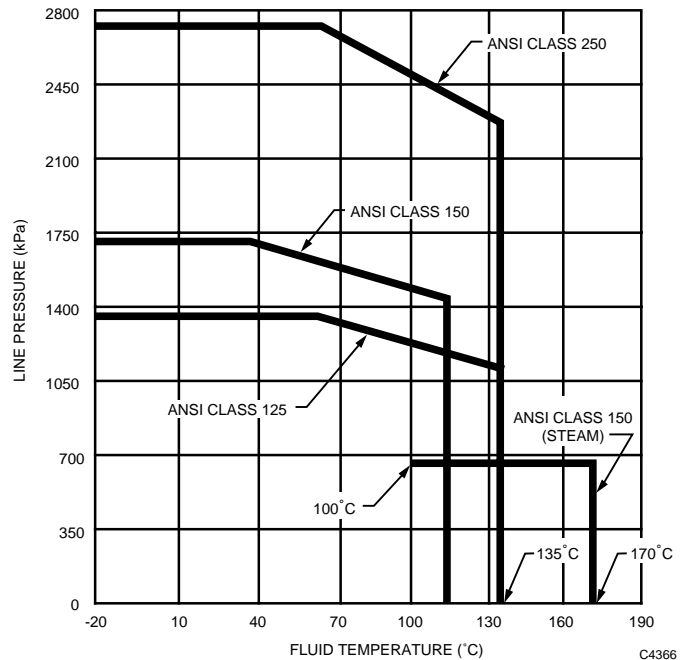

Fig. 2. ANSI Pressure-Temperature Ratings for Valves.

VALVE TYPES

Ball valve: A ball valve has a precision ball between two seats within a body (Fig. 3). Ball valves have several port sizes for a give body size and go from closed to open with a 90 degree turn of the stem. They are available in both two-way and three-way configurations. For HVAC applications, ball valve construction includes brass and cast iron bodies; stainless steel, chrome plated brass, and cast iron balls; resilient seats with various temperature ratings.

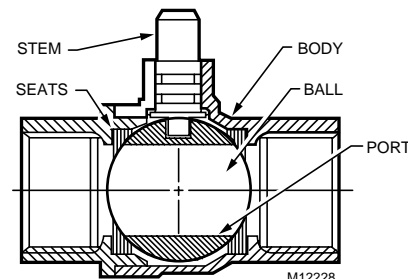

Fig. 3. Ball Valve.

Ball valves provide tight shut-off, while full port models have low flow resistance, and reduced port models can be selected for modulating applications.

Butterfly valve: A valve with a cylindrical body, a shaft, and a rotating disc (Fig. 4). The disc rotates 90 degrees from open to closed. The disc seats against a resilient body liner and may be manufactured for tight shut-off or made smaller for reduced operating torque but without tight close-off. Butterfly valves are inherently for two-way operation. For three-way applications, two butterfly valves are assembled to a pipe tee with linkage for simultaneous operation.

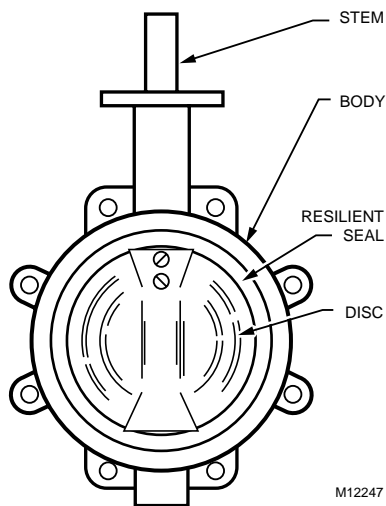

Fig. 4. Butterfly Valve.

Double-seated valve: A valve with two seats, plugs, and discs. Double-seated valves are suitable for applications where fluid pressure is too high to permit a single-seated valve to close. The discs in a double-seated valve are arranged so that in the closed position there is minimal fluid pressure forcing the stem toward the open or closed position; the pressure on the discs is essentially balanced. For a valve of given size and port area, the double-seated valve requires less force to operate than the single-seated valve so the double-seated valve can use a smaller actuator than a single-seated valve. Also, double-seated valves often have a larger port area for a given pipe size. A limitation of double-seated valves is that they do not provide tight shut-off. Since both discs rigidly connect together and changes in fluid temperature can cause either the disc or the valve body to expand or contract, one disc may seat before the other and prevent the other disc from seating tightly.

Flanged-end connections: A valve that connects to a pipe by bolting a flange on the valve to a flange screwed onto the pipe. Flanged connections are typically used on large valves only.

Globe valve: A valve which controls flow by moving a circular disk against or away from a seat. When used in throttling control a contoured plug (throttling plug) extends from the center of circular disk through the center of the seat for precise control (Fig. 1).

Pilot-operated valve: A valve which uses the differential between upstream and downstream pressure acting on a diaphragm or piston to move the valve plug. Pilot-operated valves are suitable for two-position control only. The valve actuator exerts only the force necessary to open or close the small pilot port valve that admits fluid flow into the diaphragm or piston chamber.

Reduced-Port valve: A valve with a capacity less than the maximum for the valve body. Ball, butterfly, and smaller globe valves are available with reduced ports to allow correct sizing for good control.

Screwed-end connection: A valve with threaded pipe connections. Valve threads are usually female, but male connections are available for special applications. Some valves have an integral union for easier installation.

Single-seated valve: A valve with one seat, plug, and disc. Single-seated valves are suitable for applications requiring tight shut-off. Since a single-seated valve has nothing to balance the force of the fluid pressure exerted on the plug, it requires more closing force than a double-seated valve of the same size and therefore requires more actuator force than a double-seated valve.

Three-way valve: A valve with three ports. The internal design of a three-way valve classifies it as a mixing or diverting valve. Three-way valves control liquid in modulating or two-position applications and do not provide tight shut-off.

Two-way valve: A valve with one inlet port and one outlet port. Two-way valves control water or steam in two-position or modulating applications and provide tight shut-off in both straight through and angle patterns.

VALVE MATERIAL AND MEDIA

Valves with bronze or cast iron bodies having brass or stainless steel trim perform satisfactorily in HVAC hydronic systems when the water is treated properly. Failure of valves in these systems may be an indication of inadequate water treatment. The untreated water may contain dissolved minerals (e.g., calcium, magnesium, or iron compounds) or gases (e.g., carbon dioxide, oxygen, or ammonia). Inadequate treatment results in corrosion of the system. Depending on the material of the valve, the color of the corrosion may indicate the substance causing the failure (Table 1).

Table 1. Corrosive Elements in Hydronic Systems.

Brass or Bronze Component	
Corrosive Substance	Corrosion Color
Chloride	Light Blue-Green
Ammonia	Blue or Dark Blue
Carbonates	Dark Blue-Green
Magnesium or Calcium	White
Oxides	Black (water)
Sulphide (Hydrogen)	Black (Gas)
Iron	Rust
Iron or Steel Component	
Corrosive Substance	Corrosion Color
Magnesium or Calcium	White
Iron	Rust

Glycol solutions may be used to prevent hydronic systems freezing. Glycol solutions should be formulated for HVAC systems. Some available glycol solutions formulated for other uses contain additives that are injurious to some system seals. In addition, hydronic seals react differently to water and glycol such that when a new system is started up with water or glycol the seals are effective. The hydronic seals are likely to leak if the system is later restarted with media changed from water to glycol or glycol to water. To prevent leakage part of the process of media changeover should include replacing seals such as, pump and valve packing.

VALVE SELECTION

Proper valve selection matches a valve to the control and hydronic system physical requirements. First consider the application requirements and then consider the valve characteristics necessary to meet those requirements. The following questions provide a guide to correct valve selection.

- What is the piping arrangement and size?

The piping arrangement indicates whether a two-way or three-way mixing or diverting valve is needed. The piping size gives some indication of whether the valve requires a screwed end or a flanged end connection.

- Does the application require two-position control or proportional control? Does the application require a normally open or normally closed valve? Should the actuator be direct acting or reverse acting?

In its state of rest, the valve is normally open or closed depending on the load being controlled, the fluid being controlled, and the system configuration.

For chilled water coils, it is usually preferable to close the valve on fan shutdown to prevent excessive condensation around the duct and coil, and to save pumping energy. This may be accomplished with either normally closed valves or a variety of other control schemes. Lower cost and more powerful normally open valve assemblies may be used with the close-on-shutdown feature and allow, in the case of pneumatic systems, the capability to provide heating or cooling in the event of air compressor failure.

Converter control valves should be normally closed and outdoor air preheat valves should be normally open.

- Is tight shut-off necessary? What differential pressure does the valve have to close against? How much actuator close-off force is required?

Single-seated valves provide tight shut-off, while double-seated valves do not. Double seated valves are acceptable for use in pressure bypass or in-line throttling applications.

The design and flow capacity of a valve determine how much actuator force is required for a given close-off. Therefore, the valve must first be sized, then, the valve and actuator selected to provide the required close-off.

- What type of medium is being controlled? What are the temperature and pressure ranges of the medium?

Valves must be compatible with system media composition, maximum and minimum temperature, and maximum pressure. The temperature and pressure of the medium being controlled should not exceed the maximum temperature and pressure ratings of the valve.

For applications such as chlorinated water or brine, select valve materials to avoid corrosion.

- What is the pressure drop across the valve? Is the pressure drop high enough?

The full open pressure drop across the valve must be high enough to allow the valve to exercise control over its portion of the hydronic system. However, the full open pressure drop must not exceed the valve's rating for quiet service and normal life. Closed pressure drop must not exceed valve and actuator close-off rating.

GLOBE VALVE

Globe valves are popular for HVAC applications. They are available in pipe sizes from 12 mm to 300 mm and in a large variety of capacities, flow characteristics, and temperature and pressure capabilities. They provide wide rangeability and tight shutoff for excellent control over a broad range of conditions. Globe valves are made in two-way, straight or angle configurations and three-way mixing and diverting designs. Globe valves close against the flow and have arrows on the body indicating correct flow direction. Incorrect piping can result in stem oscillations, noise, and high wear.

A two-way globe valve has one inlet port and one outlet port (Fig. 5) in either a straight through or angle pattern. The valve can be either push-down-to-close or push-down-to-open.

Pneumatic and electric actuators with linear motion to operate globe valves are available for operation with many control signals.

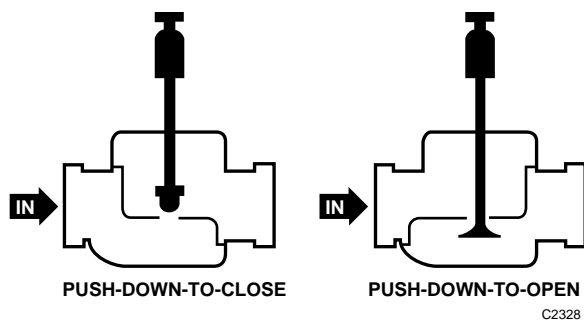

Fig. 5. Two-Way Globe Valves.

BALL VALVE

Ball valves are available for two-position applications either manual (hand) or power operated or for modulating applications with direct coupled electric actuators. Ball valves are relatively low cost and provide tight close off and available in two-way and three-way configurations. As with all other valves, ball valves must be properly sized to provide good flow control.

When used in modulating service, ball valves must be specifically designed for modulating service as compared to two-position service. Packing must provide leak-free sealing through thousands of cycles to ensure trouble-free HVAC service. The ball and stem should be made of stainless steel or similar material that minimizes sticking to the seat.

Two-way ball valves have equal percentage flow control characteristics and flow can be in either direction

Three-way ball valves can be used in either mixing or diverting service. They have linear flow control characteristics for constant total flow.

BUTTERFLY VALVE

Butterfly valves (Fig. 6) control the flow of hot, chilled, or condenser water in two-position or proportional applications. Butterfly valves are available in two-way or three-way configurations. Tight cutoff may be achieved by proper selection of actuator force and body lining. The three-way valve can be used in mixing or diverting applications with the flow in any direction. The three-way valve consists of two butterfly valves that mount on a flanged cast iron tee and are linked to an actuator which opens one valve as it closes the other. Minimum combined capacity of both valves occurs at the half-open position.

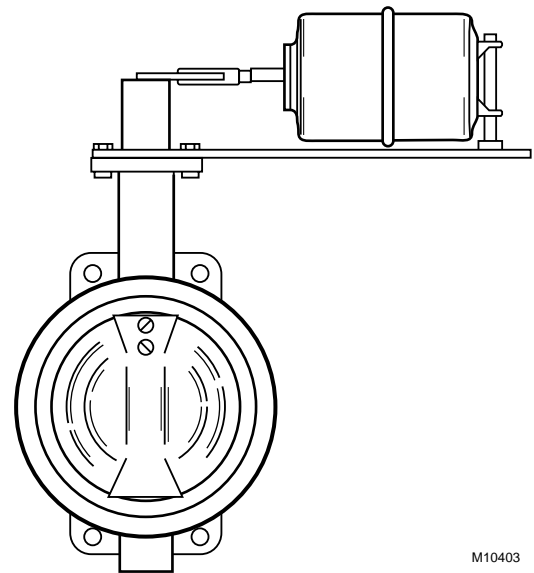

Fig. 6. Butterfly Valve.

When butterfly valves are used for proportional control, they must be applied using conservative pressure drop criteria. If the pressure drop approaches the critical pressure drop, unbalanced forces on the disc can cause oscillations, poor control, and/or damage to the linkage and actuator, even though the critical flow point is not reached.

Butterfly valves are usually found in larger pipe sizes. For example, two butterfly valves could be piped in a mixing application to control the temperature of the water going back to the condenser. The valves proportion the amount of tower water and condenser water return that is flowing in the condenser water supply line.

TWO-WAY VALVE

Two-way valves are available as globe, ball, or butterfly valves. The combination of valve body and actuator (called valve assembly) determines the valve stem position. Two-way valves control steam or water in two-position or proportional applications (Fig. 7). They provide tight shutoff and are available with quick-opening, linear, or equal percentage flow characteristics.

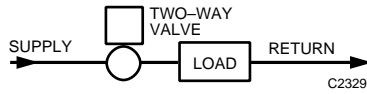

Fig. 7. Two-Way Valve Application.

Ideally, a control system has a linear response over its entire operating range. The sensitivity of the control to a change in temperature is then constant throughout the entire control range. For example, a small increase in temperature provides a small increase in cooling. A nonlinear system has varying sensitivity. For example, a small increase in temperature can provide a large increase in cooling in one part of the operating range and a small increase in another part of the operating range. To achieve linear control, the combined system performance of the actuator, control valve, and load must be linear. If the system is linear, a linear control valve is appropriate (Fig. 8). If the system is not linear, a nonlinear control valve, such as an equal percentage valve, is appropriate to balance the system so that resultant performance is linear.

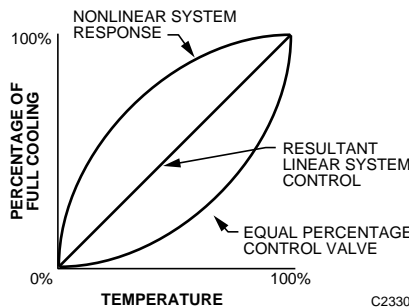

Fig. 8. Linear vs Nonlinear System Control.

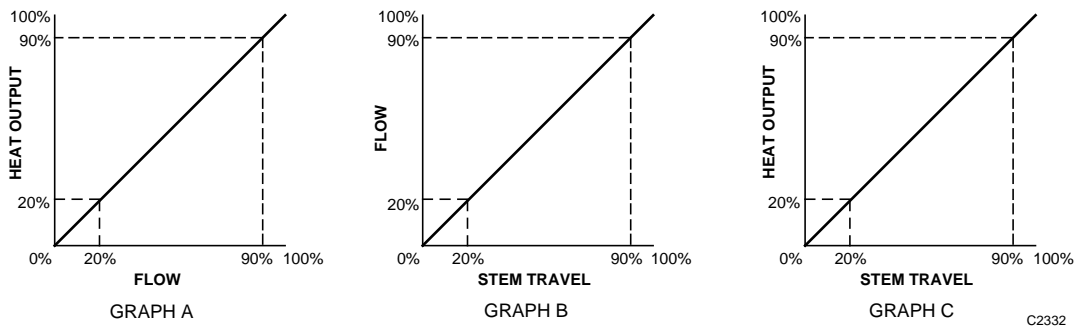

Fig. 10. Heat Output, Flow, and Stem Travel Characteristics of a Linear Valve.

QUICK-OPENING VALVE

A quick-opening two-way valve includes only a disc guide and a flat or quick-opening plug. This type of valve is used for two-position control of steam. The pressure drop for a quick-opening two-way valve should be 10 to 20 percent of the piping system pressure differential, leaving the other 80 to 90 percent for the load and piping connections. Figure 9 shows the relationship of flow versus stem travel for a quick-opening valve. To achieve 90 percent flow, the stem must open only 20 percent. Linear or equal percentage valves can be used in lieu of quick-opening valves in two-position control applications as the only significant positions are full open and full closed.

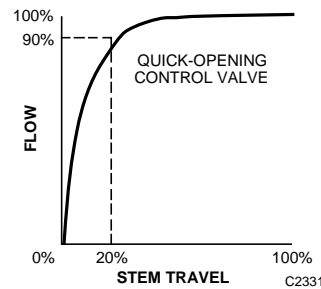

Fig. 9. Flow vs Stem Travel Characteristic of a Quick-Opening Valve.

LINEAR VALVE

A linear valve may include a V-port plug or a contoured plug. This type of valve is used for proportional control of steam or chilled water, or in applications that do not have wide load variations. Typically in steam or chilled water applications, changes in flow through the load (e.g., heat exchanger, coil) cause proportional changes in heat output. For example, Figure 10 shows the relationships between heat output, flow, and stem travel given a steam heat exchanger and a linear valve as follows:

- Graph A shows the linear relationship between heat output and flow for the steam heat exchanger. Changes in heat output vary directly with changes in the fluid flow.
- Graph B shows the linear relationship between flow and stem travel for the linear control valve. Changes in stem travel vary directly with changes in the fluid flow.

NOTE: As a linear valve just starts to open, a minimum flow occurs due to clearances required to prevent sticking of the valve. Some valves have a modified linear characteristic to reduce this minimum controllable flow. This modified characteristic is similar to an equal percentage valve characteristic for the first 5 to 10 percent of stem lift and then follows a linear valve characteristic for the remainder of the stem travel.

- Graph C shows the linear relationship between heat output and stem travel for the combined heat exchanger and linear valve. Changes in heat output are directly proportional to changes in the stem travel.

Thus a linear valve is used in linear applications to provide linear control.

EQUAL PERCENTAGE VALVE

An equal percentage valve includes a contoured plug or contoured V-port shaped so that similar movements in stem travel at any point in the flow range change the existing flow an equal percentage, regardless of flow rate.

EXAMPLE:

When a valve with the stem at 30 percent of its total lift and existing flow of 0.25 L/s (Table 2) opens an additional 10 percent of its full travel, the flow measures 0.40 L/s or increases 60 percent. If the valve opens an additional 10 percent so the stem is at 50 percent of its full travel, the flow increases another 60 percent and is 0.64 L/s.

Table 2. Stem Position Vs Flow for Equal Percentage Valve.

Stem		Flow	
Change	Position	Rate	Change
—	30% open	0.25 L/s	—
10% increase	40% open	0.40 L/s	60% increase
10% increase	50% open	0.64 L/s	60% increase

An equal percentage valve is used for proportional control in hot water applications and is useful in control applications where wide load variations can occur. Typically in hot water applications, large reductions in flow through the load (e.g., coil) cause small reductions in heat output. An equal percentage valve is used in these applications to achieve linear control. For example, Figure 11 shows the heat output, flow, and stem travel relationships for a hot water coil, with 94°C entering water and 10°C entering air and an equal percentage valve, as follows:

- Graph A shows the nonlinear relationship between heat output and flow for the hot water coil. A 50 percent reduction in flow causes a 10 percent reduction in heat output. To reduce the heat output by 50 percent, the flow must decrease 90 percent.
- Graph B shows the nonlinear relationship between flow and stem travel for the equal percentage control valve. To reduce the flow 50 percent, the stem must close 10 percent. If the stem closes 50 percent, the flow reduces 90 percent.
- Graph C shows the relationship between heat output and stem travel for the combined coil and equal percentage valve. The combined relationship is close to linear. A 10 percent reduction in heat output requires the stem to close 10 percent, a 50 percent reduction in heat output requires the stem to close 50 percent, and a 90 percent reduction in heat output requires the stem to close 90 percent.

The equal percentage valve compensates for the characteristics of a hot water application to provide a control that is close to linear.

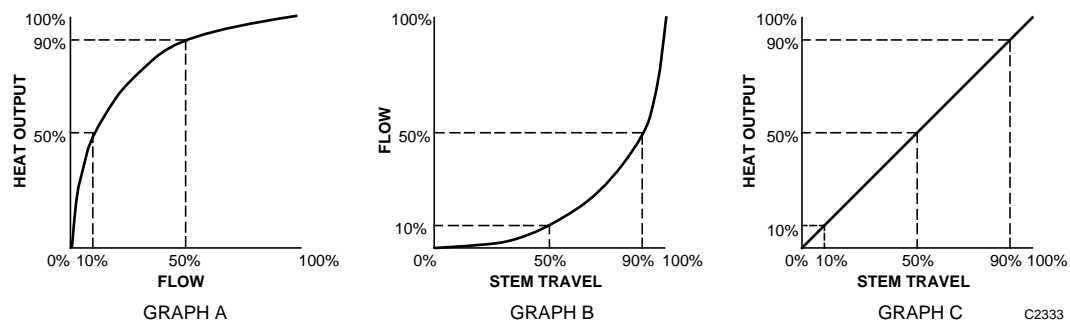

Fig. 11. Heat Output, Flow, and Stem Travel Characteristics of an Equal Percentage Valve.

THREE-WAY VALVES

Three-way valves (Fig. 12) control the flow of liquids in mixing or diverting valve applications (Fig. 13). The internal design of a three-way globe valve enables it to seat against the flow of liquid in the different applications. An arrow cast on the valve body indicates the proper direction of liquid flow. It is important to connect three-way valve piping correctly or oscillations, noise, and excessive valve wear can result. Three-way valves are typically have linear flow characteristics, although, some are equal percentage for flow through the coil with linear flow characteristics for flow through the coil bypass. Ball valves are also available in a three-way configuration, while two butterfly valves can be made to act as a three-way valve.

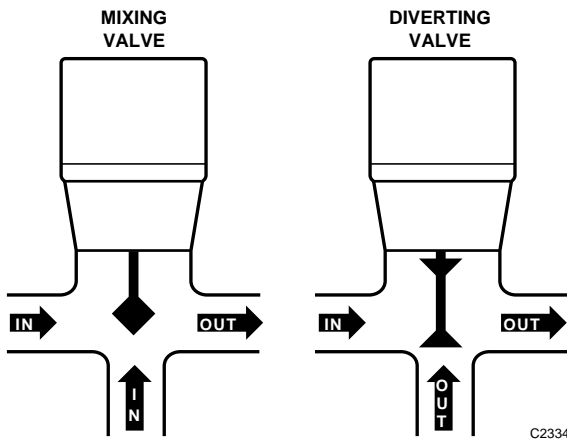
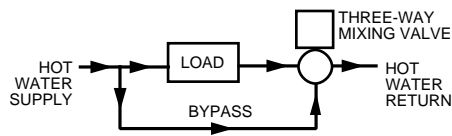
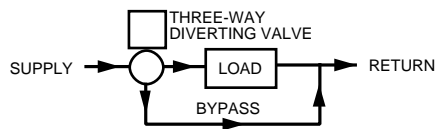

Fig. 12. Three-Way Valves.



A. LOAD BYPASS IN MIXING VALVE APPLICATION



B. LOAD BYPASS IN DIVERTING VALVE APPLICATION
C2335A

Fig. 13. Three-Way Valve Applications.

MIXING VALVE

A mixing valve provides two inlet ports and one common outlet port. The valve receives liquids to be mixed from the inlet ports and discharges the liquid through the outlet port (Fig. 12). The position of the valve disc determines the mixing proportions of the liquids from the inlet ports.

The close-off pressure in a mixing valve equals the maximum value of the greater inlet pressure minus the minimum value of the downstream pressure.

EXAMPLE:

A mixing valve application has a maximum pressure of 170 kPa on one inlet port, maximum pressure of 140 kPa on the other inlet port, and minimum downstream pressure of 70 kPa on the outlet port. The close-off pressure is $170 \text{ kPa} - 70 \text{ kPa} = 100 \text{ kPa}$. The application requires a mixing valve with at least a 100 kPa close-off rating. The actuator selected must have a high enough force to operate satisfactorily.

In globe mixing valve applications, the force exerted on the valve disc due to unbalanced pressure at the inlets usually remains in the same direction. In cases where there is a reversal of force, the force changes direction and holds the valve disc off the seat, cushioning it as it closes. If the pressure difference for the system is greater than the pressure ratings of available globe mixing valves, use a ball mixing valve or two butterfly valves in a tee configuration.

Globe mixing valves are not suitable for modulating diverting valve applications. If a mixing valve is piped for modulating diverting service, the inlet pressure slams the disc against the seat when it nears the closed position. This results in loss of control, oscillations, and excessive valve wear and noise. Mixing valves are acceptable using about 80 percent of the close-off rating, but not recommended, in two-position diverting valve applications.

DIVERTING VALVE

A globe diverting valve provides one common inlet port and two outlet ports. The diverting valve uses two V-port plugs which seat in opposite directions and against the common inlet flow. The valve receives a liquid from one inlet port and discharges the liquids through the outlet ports (Fig. 12) depending on the position of the valve disc. If the valve disc is against the bottom seat (stem up), all the liquid discharges through the side outlet port. If the valve disc is against the top seat (stem down), all the liquid discharges through the bottom outlet port.

The close-off pressure in a diverting valve equals the maximum value of the inlet pressure minus the minimum value of the downstream pressure.

Globe diverting valves must not be used for mixing service. As with mixing valves used for diverting service, media pressure drop across the valve can cause it to slam shut with resulting loss of control.

VALVE SIZING

Every valve has a capacity index or flow coefficient (K_V). Typically determined for the globe and ball valves at full open and about 60 degrees open for butterfly valves. K_V is the quantity of water in cubic meters per hour between 5 and 40°C that flows through a valve with a pressure differential of 10⁵ pascals. Sizing a valve requires knowing the medium (liquid or gas) and the required pressure differential to calculate the required K_V . When the required K_V is not available in a standard valve, select the next closest and calculate the resulting valve pressure differential at the required flow to verify to verify acceptable performance.

After determination of the valve K_V , calculation of the flow of any medium through that valve can be found if the characteristics of the medium and the pressure drop across the valve are known.

WATER VALVES

Determine the capacity index (K_V) for a valve used in a water application, using the formula:

$$K_V = Q \sqrt{\frac{\rho}{\Delta P \cdot 10}}$$

Where:

- Q = Flow of fluid in cubic meters per hour required to pass through the valve.
- ρ = Specific gravity of the fluid (water = 1000 kg/m³).
- ΔP = Pressure drop in kPa. See Figures 14 and 15 for glycol solution correction values.

EXAMPLE:

A diverting valve application has 140 kPa maximum on the inlet port, one outlet port discharging to the atmosphere, and the other outlet port connecting to a tank under 70 kPa constant pressure. The pressure difference between the inlet and the first outlet port is 140 kPa and between the inlet and second outlet port is 70 kPa. The application requires a diverting valve with at least 140 kPa close-off rating.

Determining the K_V of a water valve requires knowing the quantity of water (m³/h) through the valve and the pressure drop (ΔP) across the valve. If the fluid is a glycol solution, use the pressure drop multipliers from either Figure 14 or 15. See the sections on QUANTITY OF WATER and WATER VALVE PRESSURE DROP. Then select the appropriate valve based on K_V , temperature range, action, body ratings, etc., per VALVE SELECTION guidelines.

REPRINTED BY PERMISSION FROM ASHRAE HANDBOOK—
1996 HVAC SYSTEMS AND EQUIPMENT

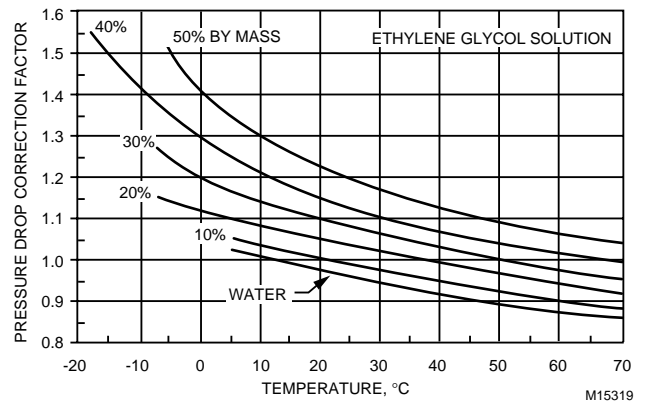

Fig. 14. Pressure Drop Correction for Ethylene Glycol Solutions.

REPRINTED BY PERMISSION FROM ASHRAE HANDBOOK—
1996 HVAC SYSTEMS AND EQUIPMENT

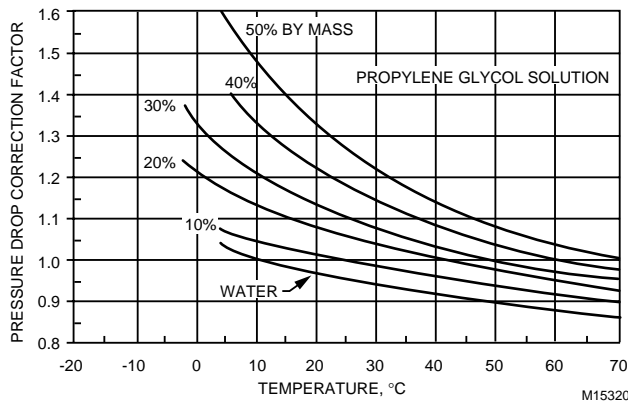

Fig. 15. Pressure Drop Correction for Propylene Glycol Solutions.

QUANTITY OF WATER

To find the quantity of water (Q) in cubic meters per hour use one of the following formulas:

$$Q = \frac{\text{watts}}{S \cdot \Delta T_w}$$

1. When heat flow rate is known:

Where:

- watts = Heat flow rate.
- ΔT_w = Temperature difference of water entering and leaving the coil.
- S = Value from Table 3; based on temperature of water entering the coil.

Table 3. Water Flow Formula Table.

Water Temp °C	S	Water Temp °C	S
20	1158	105	1121
30	1154	120	1114
40	1150	135	1108
50	1145	150	1101
60	1141	165	1094
75	1134	180	1088
90	1128	200	1080

2. For hot water coil valves:

$$Q = \frac{1202.4}{S} \cdot \frac{m^3}{s} \cdot \frac{\Delta T_a}{\Delta T_w}$$

Where:

- m^3/s = Airflow through the coil.
- 1202.4 = A scaling constant.
- ΔT_a = Temperature difference of air entering and leaving the coil.
- S = Value from Table 3; based on temperature of water entering the coil.
- ΔT_w = Temperature difference of water entering and leaving the coil.

3. For fan system chilled water coil valves:

$$Q = 1.02 \frac{m^3}{s} \cdot \frac{\text{Heat removed}}{\Delta T_w}$$

Where:

- m^3/s = Airflow through the coil.
- Heat removed = Heat per kilogram of dry air removed in kJ/kg. Includes both sensible and latent heat.
- 1.02 = A scaling constant.
- ΔT_w = Temperature difference of water entering and leaving the coil.

WATER VALVE PRESSURE DROP

To determine valve pressure drop:

1. For two-way valves consider the following guidelines for valve pressure drop:
 - a. Include the pressure drop in the design of the water circulating system.
 - In systems with two-way valves only, it is often necessary to provide a pump relief bypass or some other means of differential pressure control to limit valve pressure drops to the valve capabilities. For control stability at light loads, pressure drop across the fully closed valve should not exceed triple the pressure drop used for sizing the valve.
 - To avoid high pressure drops near the pump, reverse returns are recommended in large systems.

- b. The pressure drop across an open valve should be about half of the pressure difference between system supply and return, enough so that the valve, not the friction through the coil or radiator, controls the volume of water flow or the valve pressure drop should be equal to or greater than the pressure drop through the coil or radiator, plus the pipe and fittings connecting them to the supply and return mains.
 - c. Verify allowable full open and full closed pressure drops for all proportional and two-position water valves with appropriate manufacturer literature.
 - d. Make an analysis of the system at maximum and minimum rates of flow to determine whether or not the pressure difference between the supply and return mains stays within the limits that are acceptable from the stand point of control stability and close-off rating.
2. For two- and three-way valves consider the following guidelines for valve pressure drop:
 - a. In load bypass applications (Fig. 13) such as radiators, coils, and air conditioning units, the pressure drop should be 50 to 70 percent of the minimum difference between the supply and return main pressure at design operating conditions.
 - b. A manual balancing valve may be installed in the bypass to equalize the load drop and the bypass drop.
 3. When selecting pressure drops for three-way mixing valves in boiler bypass applications (Fig. 13), consider the following:
 - a. Determine the design pressure drop through the boiler including all of the piping, valves, and fittings from the bypass connection through the boiler and up to the three-way valve input.
 - b. The valve pressure drop should be equal to or greater than the drop through the boiler and the fittings. If the valve drop is much smaller than the boiler pressure drop at design, effective control is obtained only when the disc is near one of the two seats. The mid-portion of the valve lift will be relatively ineffective.
 - c. A manual balancing valve may be installed in the boiler bypass to equalize the boiler drop and the bypass drop.

WATER VALVE SIZING EXAMPLES

EXAMPLE 1:

A two-way linear valve is needed to control flow of 7°C chilled water to a cooling coil. The coil manufacturer has specified an eight-row coil having a water flow pressure drop of 22 kPa. Further, specifications say that the coil will produce 13°C leaving air with a water flow of 3.32 m³/h. Supply main is maintained at 275 kPa, return is at 200 kPa. Select required capacity index (K_v) of the valve.

Use the water valve K_v formula to determine capacity index for Valve V1 as follows:

$$K_v = Q \sqrt{\frac{\rho}{\Delta P \cdot 10}}$$

Where:

Q = Flow of fluid in Cubic meters per hour required is 3.32 m³/h.

ρ = Density of water is 1000.

ΔP = Pressure drop across the valve. The difference between the supply and return is 75 kPa. 50% to 70% x 75 kPa = 37.5 to 52.7 kPa. Use 40 kPa for the correct valve pressure drop. Note that 40 kPa is also greater than the coil pressure drop of 22 kPa.

Substituting:

$$K_v = 3.32 \sqrt{\frac{1000}{40 \cdot 10}} = 5.2$$

Select a linear valve providing close control with a capacity index of 5.4 and meeting the required pressure and temperature ratings.

EXAMPLE 2:

A bypass valve is required to prevent flow through the chiller from dropping below 90 percent of design flow. When sizing valves for pump or chiller bypass applications (Fig. 16), system conditions that cause the valve to open or close completely must be considered before a pressure drop can be selected.

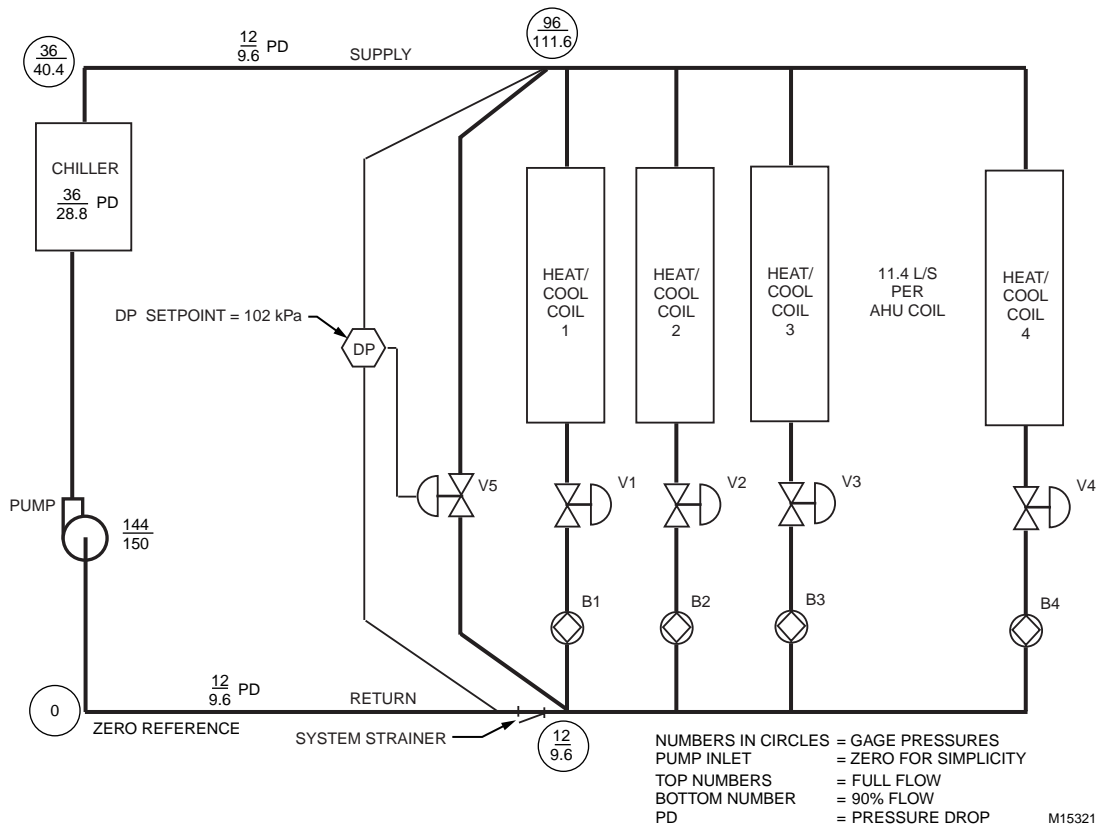

Fig. 16. Chiller Bypass Application.

Assume the following:

- System flow at design, 225 m³/h
- Pump pressure at design, 144 kPa
- Pump pressure at 90 percent flow, 150 kPa
- Pressure across mains at AHU 1 at design flow, 84 kPa
- Chiller pressure drop, 36 kPa
- Chiller piping loop design pressure drop, 24 kPa

With full system flow, Valve V5 is closed. Pressure drop across V5 equals the pump pressure minus the friction drops to V5. Pressure drop across Valve V5 is then 144 kPa – 36 kPa (chiller drop) – 12 kPa (supply drop) – 12 kPa (return drop) or 84 kPa.

With system flow at 90 percent, the pump pressure rises to 150 kPa, while the friction drops fall to the lower values shown in Figure 16. For additional information on chiller bypass operation see Chiller, Boiler, and Distribution System Applications section. Pressure drop across V5 equals the pump pressure minus the friction drops to V5. Pressure drop across Valve V5 is then 150 kPa – 28.8 kPa (chiller drop) – 9.6 kPa (supply drop) – 9.6 kPa (return drop) or 102.

Substituting the flow of water, specific gravity of water, and pressure drop in the K_v formula shows that the Valve V5 should have a K_v of 223.

$$K_v = 225 \sqrt{\frac{1000}{102 \cdot 10}} = 222.8$$

EXAMPLE 3:

Sizing water valves for heating coils is especially critical. In Figure 17, a valve with a K_v of 10 will have 30 percent of the available pressure drop when full open, while a valve with a K_v of 4.4 will have 70 percent of the available pressure drop. As shown in Figure 18, the valve with 70 percent of the available pressure drop essentially provides the equal percentage water flow control, resulting in linear coil heat transfer and stable temperature control. The valve with only 30 percent of the available pressure drop has a more linear flow control which results in nonlinear coil heat transfer. See EQUAL PERCENTAGE VALVE section for further information.

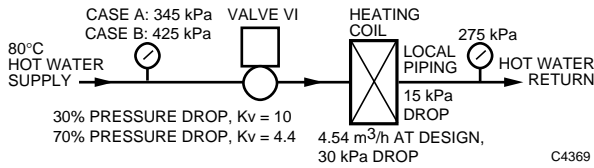

Fig. 17. Equal Percentage Valve Hot Water Application.

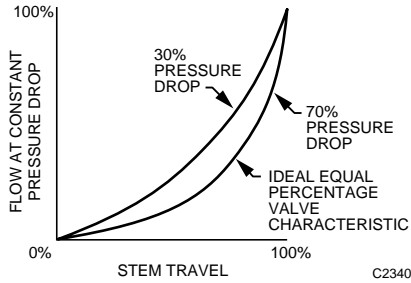

Fig 18. Effect of Pressure Drop in Hot Water Valve Sizing.

EXAMPLE 4:

A three-way mixing valve is needed for a heat exchanger application with a bypass line. Water flow is specified at the rate of 16 m³/h. Manufacturer data for the exchanger indicates a pressure drop of 4.2 kPa through the exchanger coils.

Use the water valve K_v formula to determine capacity index for Valve V1 as follows:

$$K_v = Q \sqrt{\frac{\rho}{\Delta P \cdot 10}}$$

Where:

- Q = Flow of fluid required to pass through the valve is 16 m³/h.
- ρ = Density of water is 1000.
- ΔP = Pressure drop across the valve. Plans of the heating system indicate 80-mm supply and return mains. From an elbow equivalent table and pipe friction chart found in the ASHRAE Handbook or other reference manuals, the calculated pressure drop through a 80-mm tee and the piping from the valve and the tee to the exchanger is 0.62 kPa. Heat exchanger pressure drop is 4.2 kPa. Total pressure drop from bypass connection through the heat exchanger and to the hot-water input of the three-way valve is 4.2 kPa + 0.62 kPa or 4.82 kPa.

Since the valve pressure drop (ΔP) should be equal to or greater than the drop through the heat exchanger and fittings, 4.82 kPa is used as the valve pressure drop.

For optimum control, a manual balancing valve is installed in the bypass line to equalize the pressure drops in the exchanger and bypass circuits.

Substituting the flow of water, density of water, and pressure drop in the K_v formula shows that the valve should have a K_v of 72.8 or 73.

$$K_v = 16 \sqrt{\frac{1000}{4.82 \cdot 10}} = 72.8$$

Select a linear valve providing close control with a capacity index of 73

STEAM VALVES

Calculate the required capacity index (K_v) for a valve used in a saturated steam application, using the formula:

$$K_v = \frac{Q}{0.224 \sqrt{\Delta P \cdot P_o}}$$

Where:

- Q = Quantity of steam in kilograms per hour required to pass through the valve.
- 0.224 = A scaling constant.
- ΔP = Pressure drop in kPa.
- P_o = Absolute outlet pressure of valve in kilopascals (P₁ - ΔP).

Calculate the required capacity index (K_v) for a valve used in a superheated steam application, using the formula:

$$K_v = \frac{Q}{3.15 - \left(1.55 \cdot \frac{\Delta P}{P_1}\right)} \sqrt{\frac{V_1}{\Delta P}}$$

Where:

- Q = Quantity of steam in kilograms per hour required to pass through the valve.
- ΔP = Pressure drop in kPa.
- P₁ = Absolute inlet in kilopascals.
- V₁ = Inlet specific volume in cubic centimeters per kilogram.

Determining the K_v for a steam valve requires knowing, the quantity of steam (Q) through the valve, the pressure drop (ΔP) across the valve, and the degrees of superheat. See QUANTITY OF STEAM and STEAM VALVE PRESSURE DROP. Then select the appropriate valve based on K_v , temperature range, action, body ratings, etc., per VALVE SELECTION guidelines.

QUANTITY OF STEAM

To find the quantity of steam (Q) in kilograms per hour use one of the following formulas:

1. When heat output is known:

$$Q = \frac{\text{Heat Output}}{2325 \text{ kJ/kg}}$$

Where:

Heat output = Heat output in kJ/kg.
 2325 kJ/kg = The approximate heat of vaporization of steam.

2. For sizing steam coil valves:

$$Q = \frac{m^3/s \times \Delta T_a \times 4330}{2325 \text{ kJ/kg}}$$

Where:

m³/s = Volume of air from the fan in cubic meters per second.
 ΔT_a = Temperature difference of air entering and leaving the coil.
 4330 = A scaling constant.
 2325 kJ/kg = The approximate heat of vaporization of steam.

3. For sizing steam to hot water converter valves:

$$Q = L/s \times DT_w \times 6.462$$

Where:

L/s = Water flow through converter in liters per second.
 ΔT_w = Temperature difference of water entering and leaving the converter.
 6.462 = A scaling constant.

4. When sizing steam jet humidifier valves:

$$Q = \frac{(W_1 - W_2) \text{g moisture}}{\text{kg air}} \cdot \frac{1.2045 \text{ kg air}}{\text{m}^3} \cdot \frac{\text{m}^3}{\text{s}} \cdot \frac{3600 \text{ s}}{\text{h}}$$

Where:

W₁ = Humidity ratio entering humidifier, grams of moisture per kilogram of dry air.
 W₂ = Humidity ratio leaving humidifier, grams of moisture per kilogram of dry air.
 1.2045 kg/m³ = The specific weight of air at standard conditions of temperature (20°C) and atmospheric pressure (101.325 kPa).
 m³/s = Volume of air from the fan in cubic meters per second.
 3600 s/h = A conversion factor from second to hours.

Simplifying:

$$Q = 4.3362 \frac{(W_1 - W_2) \text{kg moisture}}{\text{hr}}$$

STEAM VALVE PRESSURE DROP

Proportional Applications

When specified, use that pressure drop (ΔP) across the valve.

When not specified:

1. Calculate the pressure drop (ΔP) across the valve for good modulating control:

$$\Delta P = 80\% \times (P_1 - P_2)$$

NOTE: For a zone valve in a system using radiator orifices use:

$$\Delta P = (50 \text{ to } 75)\% \times (P_1 - P_2)$$

Where

P₁ = Pressure in supply main in kPa absolute.
 P₂ = Pressure in return in kPa absolute.

2. Determine the critical pressure drop:

$$\Delta P_{\text{critical}} = 50\% \times P_{1a}$$

Where:

P_{1a} = Pressure in supply main in kPa (absolute pressure)

Use the smaller value ΔP or ΔP_{critical} when calculating K_v.

Two-Position Applications

Use line sized valves whenever possible. If the valve size must be reduced, use:

$$\Delta P = 20\% \times (P_1 - P_2)$$

Where

P₁ = Pressure in supply main in kPa absolute.
 P₂ = Pressure in return in kPa absolute.

STEAM VALVE SIZING EXAMPLES

EXAMPLE 1:

A two-way linear valve (V1) is needed to control high-pressure steam flow to a steam-to-water heat exchanger. An industrial-type valve is specified. Steam pressure in the supply main is 650 kPa with no superheat, pressure in return is equal to atmospheric pressure, water flow is 5.2 L/s, and the water temperature difference is 10 kelvins.

Use the steam valve K_V formula to determine capacity index for Valve V1 as follows:

$$K_V = \frac{Q}{0.224 \sqrt{\Delta P \cdot P_o}}$$

Where:

Q = The quantity of steam required to pass through the valve is found using the converter valve formula:

$$Q = L/s \cdot \Delta T_w \cdot 6.462$$

Where:

L/s = 5.2 L/s water flow through exchanger
 ΔT_w = 10 kelvins temperature difference
 6.462 = A scaling constant

Substituting this data in the formula:

$$Q = 329.7 \text{ kilograms per hour}$$

ΔP = The pressure drop across a valve in a modulating application is:

$$\Delta P = 80\% \times (P_1 - P_2)$$

Where:

P_1 = Upstream pressure in supply main is 650 kPa.
 P_2 = Pressure in return is atmospheric pressure or 101.325 kPa.

Substituting this data in the pressure drop formula:

$$\begin{aligned} \Delta P &= 0.80 \times (650 - 101.3) \\ &= 0.80 \times 548.7 \\ &= 439 \text{ kPa} \end{aligned}$$

The critical pressure drop is found using the following formula:

$$\Delta P_{\text{critical}} = 50\% \times \text{kPa}$$

$$\begin{aligned} \Delta P_{\text{critical}} &= 0.50 \times 650 \text{ kPa} \\ &= 325 \text{ kPa} \end{aligned}$$

The critical pressure drop ($\Delta P_{\text{critical}}$) of 325 kPa is used in calculating K_V , since it is less than the pressure drop (ΔP) of 439 kPa. Always, use the smaller of the two calculated values.

$$\begin{aligned} Q &= 329.7 \text{ kg/h} \\ \Delta P &= \Delta P_{\text{critical}} = 325 \text{ kPa} \\ P_o &= P_1 - \Delta P = 650 \text{ kPa} - 325 \text{ kPa} = 325 \text{ kPa} \\ 0.224 &= \text{A scaling constant.} \end{aligned}$$

Substituting the quantity of steam and pressure drop in the K_V formula shows that the valve should have a K_V of 4.5.

$$\begin{aligned} K_V &= \frac{329.7}{0.224 \sqrt{325 \cdot 325}} \\ &= \frac{329.7}{0.224 \times 325} = 4.53 \end{aligned}$$

Select a linear valve providing close control with a capacity index of 4.5 and meeting the required pressure and temperature ratings.

NOTE: For steam valves downstream from pressure reducing stations, the steam will be superheated in most cases and must be considered.

EXAMPLE 2:

In Figure 19, a linear valve (V1) is needed for accurate flow control of a steam coil that requires 325 kilograms per hour of steam. Upstream pressure in the supply main is 150 kPa and pressure in the return is 90 kPa minimum.

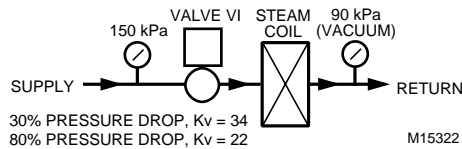

Fig. 19. Linear Valve Steam Application.

Use the steam valve K_V formula to determine capacity index for Valve V1 as follows:

$$K_V = \frac{Q}{0.224\sqrt{\Delta P \cdot P_o}}$$

Where:

Q = Quantity of steam required to pass through the valve is 325 kilograms per hour.

ΔP = The pressure drop across a valve in a modulating application is found using:

$$\Delta P = 80\% \times (P_1 - P_2)$$

and:

P_1 = Upstream pressure in supply main is 150 kPa.

P_2 = Pressure in return is 90 kPa.

$$\begin{aligned} \Delta P &= 0.80 \times (150 - 90) \\ &= 0.80 \times 60 \\ &= 48 \text{ kPa} \end{aligned}$$

The critical pressure drop is found using the following formula:

$$h_{\text{critical}} = 50\% \times \text{kPa (upstream)}$$

$$\begin{aligned} h_{\text{critical}} &= 0.50 \times 150 \text{ kPa} \\ &= 75 \text{ kPa} \end{aligned}$$

The pressure drop (ΔP) of 48 kPa is used in calculating the K_V , since it is less than the critical pressure drop ($\Delta P_{\text{critical}}$) of 75 kPa.

$$\begin{aligned} P_o &= \text{Absolute outlet pressure of the valve in kPa} \\ &= P_1 - \Delta P \\ &= 150 \text{ kPa} - 48 \text{ kPa} = 102 \text{ kPa} \end{aligned}$$

0.224 = A scaling constant.

Substituting the quantity of steam and pressure drop in the K_V formula shows that Valve V1 should have a K_V of 22.3 or the next higher available value.

$$\begin{aligned} K_V &= \frac{325}{0.224\sqrt{48 \cdot 102}} \\ &= \frac{325}{0.224 \times 69.97} = 20.7 \end{aligned}$$

Select a linear valve providing close control with a capacity index of 22.3 and meeting the required pressure and temperature ratings.

EXAMPLE 3:

Figure 20 shows the importance of selecting an 80 percent pressure drop for sizing the steam valve in Example 2. This pressure drop (48 kPa) approximates the linear valve characteristic. If only 30 percent of the available pressure drop is used ($0.30 \times 60 \text{ kPa} = 18 \text{ kPa}$), the valve K_V becomes:

$$\begin{aligned} K_V &= \frac{Q}{0.224\sqrt{\Delta P \cdot P_o}} \\ K_V &= \frac{325}{0.224\sqrt{18 \cdot 132}} = 29.8 \end{aligned}$$

This larger valve (18 kPa drop) has a steeper curve that is further away from the desired linear valve characteristic. See LINEAR VALVE under VALVE SELECTION for more information.

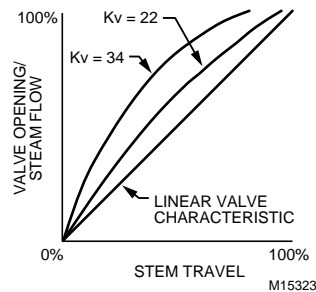

Fig. 20. Effect of Pressure Drop in Steam Valve Sizing.

Damper Selection and Sizing

ENGINEERING MANUAL OF AUTOMATIC CONTROL

CONTENTS

Introduction	447
Definitions	447
Damper Selection	448
Damper Types	448
Parallel and Opposed Blade Dampers	448
Round Dampers	448
Low Leakage Dampers	448
Smoke Dampers	450
Fire Dampers	450
Multiple Section Dampers	451
Baffles	451
Typical Damper Construction	452
Performance Data	452
Leakage Ratings	452
Torque Requirements	454
Velocity Ratings	454
Temperature Ratings	454
Pressure Ratings	454
UL Classification (Fire/Smoke)	454
Application Environment	454
Velocity	454
Static Pressure	455
Temperature	455
Corrosion	455
Turbulence	455
Nuclear/Seismic Applications	455
Actuators and Linkages	455
Normally Open/Normally Closed	455
Actuator Mounting Alternatives	456
Positive Positioners	456
Multiple Actuators	456
Jackshafts	457
Actuator Selection	457

Damper Sizing	457
System Characteristics	457
Damper Characteristics	458
Inherent Characteristic	458
Installed Characteristic	458
Determining Damper Size	459
Other Damper Sizing Considerations	461
Two-Position Control	461
Modulating Control	461
Oversized Damper Characteristics	461
Damper Performance	461
Control System Sensitivity	461
Damper Pressure Drop	462
Damper Applications	463
Mixed Air Control	463
Face and Bypass Control	464
Throttling Control	464

INTRODUCTION

This section familiarizes the reader with dampers, including types, construction, performance, environment capability, actuators, and linkages, and describes criteria used for proper selection and sizing of dampers. Dampers are typically chosen based on duct size and convenience of location. Rather than using duct size, criteria and methods are provided to select and properly size dampers which will produce desired control results. This can eliminate the undesirable effects of oversized dampers.

The information provided is general for all dampers. Selection and sizing of specific dampers can only be accomplished through the use of specific manufacturer's documentation.

Dampers in HVAC systems regulate the flow of air either by modulating or two-position control. They are normally connected to actuators by linkages and operate in response to a pneumatic, electric, or electronic control signal. In theory, the application of dampers in HVAC systems closely parallels that of control valves.

DEFINITIONS

Actuator: A device used to operate a damper or control valve in a control system.

Baffle: An orifice placed in the duct to reduce the duct size to the damper size.

Damper seals: Construction features used to minimize the leakage through a damper.

Damper system: The damper plus the series resistance that relates to it (e.g., duct work, mixing boxes, diffusers, and coils).

Damper: A device used to regulate the flow of air in an HVAC system by modulating or two-position control.

Drive blade: A damper blade that is driven directly by an actuator or by a linkage, axle, or jackshaft connected to the drive blade in an adjacent damper section.

Fire damper: A thermally actuated damper arranged to automatically restrict the passage of fire and/or heat at a point where an opening violates the integrity of a fire partition or floor.

Ideal damper system: A system with a linear relationship between the percent open damper position and the percent of full airflow.

Leakage: The amount of air passing through a damper with a given pressure drop and a given torque holding the damper closed.

Opposed blade damper: A damper constructed so adjacent blades rotate opposite to each other.

Parallel blade damper: A damper constructed so each blade rotates in the same direction as the blade next to it.

Smoke damper: A damper arranged to control passage of smoke through an opening or a duct.

DAMPER SELECTION

DAMPER TYPES

PARALLEL AND OPPOSED BLADE DAMPERS

Parallel blade dampers are constructed so each blade rotates in parallel with or in the same direction as the blade next to it (Fig. 1). The rotation changes the direction of airflow and can provide mixing with only a small increase in airflow resistance.

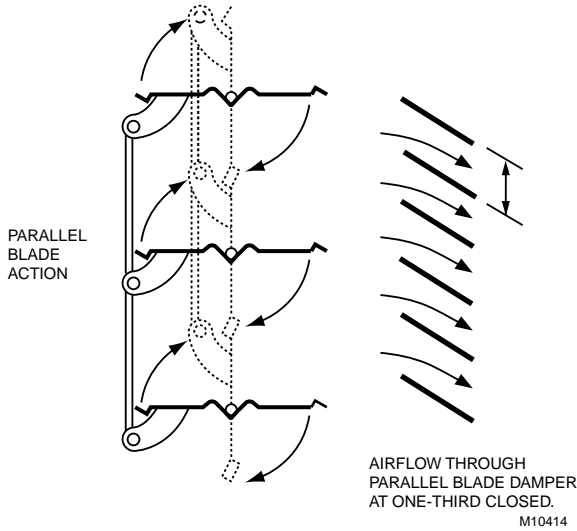

Fig. 1. Parallel Blade Damper.

Opposed blade dampers are constructed so adjacent blades rotate opposite to each other (Fig. 2). The rotation does not change the direction of airflow, but it does increase resistance to and stratification of airflow since the air is funneled through a smaller opening. An opposed blade damper must be open further to obtain the same resistance to airflow as a parallel blade damper.

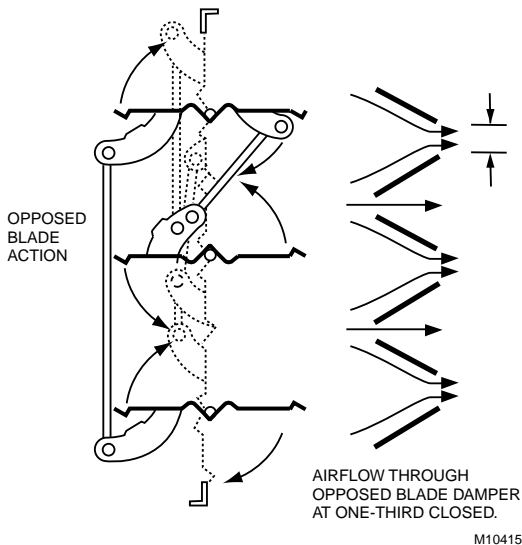

Fig. 2. Opposed Blade Damper.

ROUND DAMPERS

Round dampers (Fig. 3) are typically used to control flow in ducts that usually have high static pressure and high velocity characteristics. Round dampers can be installed in air handling systems with spiral-wound ducts in sizes similar to rectangular ducts. The smallest sizes of round dampers have a butterfly type blade while larger ones might be multiblade.

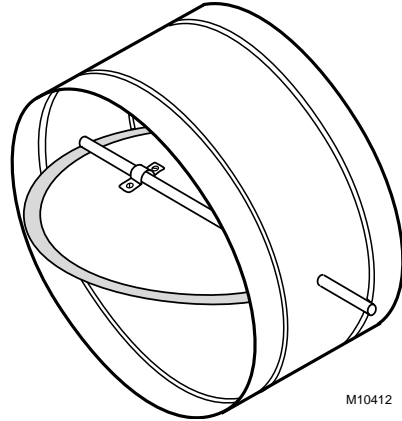

Fig. 3. Round Damper.

LOW LEAKAGE DAMPERS

Low leakage dampers minimize the amount of leakage through a fully closed damper. This can increase the energy efficiency of the control system, the comfort level in occupied spaces, and the safe operation of control elements such as coils. Low leakage is achieved through a variety of damper features and parameters, including blade edge seals, blade side seals, blade linkage, blade and frame reinforcements, and seal material.

Damper blade edge seals that work in compression between the blades e.g., cellular foam strip, (Fig. 4) are effective when blades are rigid enough to prevent misalignment and bending. Other types of blade edge seals include:

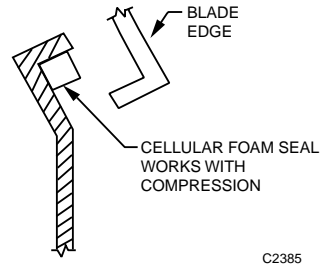
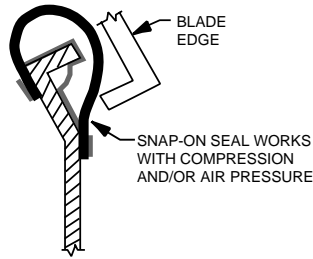

Fig. 4. Cellular Foam Blade Edge Seal.

- Snap-on seals, extruded plastic or dual durometer elastomer types (Fig. 5)
- Over-center compression seals, extruded plastic or roll-form construction (Fig. 6)
- Inflatable seals (rubber or silicone) that use the pressure differential across the damper for tight sealing when closed (Fig. 7)



C2387

Fig. 5. Snap-On Blade Edge Seal.

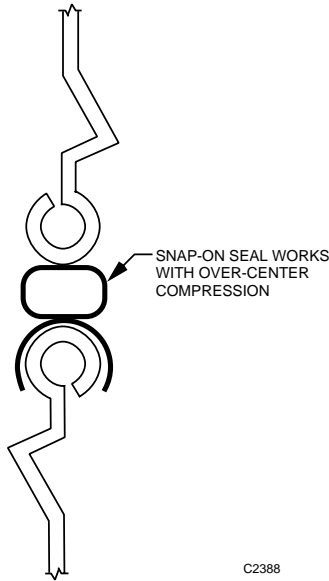

C2388

Fig. 6. Over-Center Compression Blade Edge Seal.

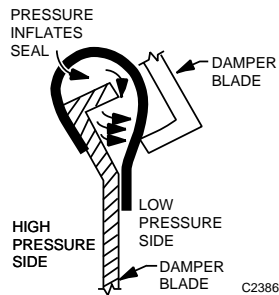

C2386

Fig. 7. Inflatable Blade Edge Seal.

Blade side seals minimize leakage between the ends of the blades and the frame (Fig. 8). One type of side seal is a stainless steel or coated spring steel spring. Other types of side seals (e.g., molded rubber parts riveted to the frame) conform to the blade cross-section profile when the damper is closed. Blade edge seals that interfere with blades closing completely could increase leakage at blade side seals.

The twisting load on damper blades and/or their physical size may necessitate heavy-duty or double linkage between blades to minimize torsional bending. Bending of damper blades reduces the effectiveness of blade edge seals by lowering compression forces or by preventing complete contact between blades.

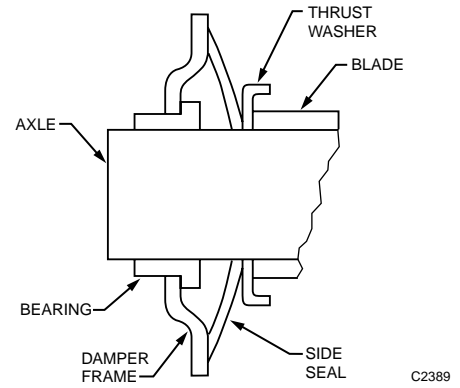

C2389

Fig. 8. Continuous Spring, Stainless Steel Blade Side Seals.

In addition, damper blades can include a reinforcing element to limit blade torsion or twist (Fig. 9). Depending on the damper size and sealing requirement, this reinforcement can be on the drive blade only or on multiple blades. The design of air foil blades usually increases their torsional stiffness, much like reinforced standard blades (Fig. 10). Air foil blades also reduce noise and provide lower, full open airflow resistance at higher velocities.

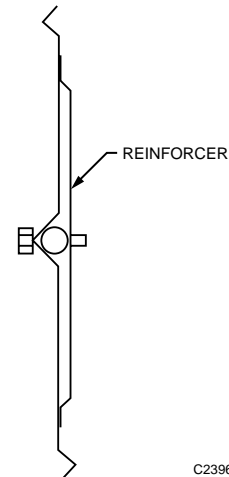

C2396

Fig. 9. Reinforced Standard Damper Blade.



C2397

Fig. 10. Air Foil Type Blade

DAMPER SELECTION AND SIZING

In a low leakage damper, materials for the seals are selected based on the temperature of the air being controlled. Standard seals can be upgraded to withstand higher temperatures by using a more heat resistant material. An example would be changing a blade edge seal from neoprene to silicone rubber.

When duct static pressure is relatively low but leakage must be minimal, a low leakage damper with reduced static pressure ratings may be used. Generally, as the strength of a given damper increases, velocity and static pressure drop capabilities increase.

SMOKE DAMPERS

Any damper that controls airflow is capable of controlling smoke. In order to apply dampers to smoke control systems properly, UL 555S, Standard for Leakage Rated Dampers for Use in Smoke Control Systems, provides classification based on leakage, differential pressure across the damper, maximum velocity when the damper is fully open, temperature, and damper size. This classification includes the specific actuator used. See Table 1 for leakage classifications.

Table 1. UL 555S Maximum Allowable Damper Leakage Classifications.

Leakage Classification	Cfm per sq ft at 1 in. wc	Cfm per sq ft at 4 in. wc
O	0	0
I	4	8
II	10	20
III	40	80
IV	60	120
Approximate SI Equivalent	m ³ /s per sq m at 0.249 kPa	m ³ /s per sq m at 0.995 kPa
O	0	0
I	0.020	0.041
II	0.051	0.102
III	0.203	0.406
IV	0.305	0.610

In designing a smoke damper, a manufacturer develops a product line with Maximum A and B and Minimum A and B dimensions where:

- A = Overall damper size in the direction of the blade length.
- B = Overall damper size perpendicular to the blade length.

The three damper sizes tested by UL are Maximum A/Minimum B, Minimum A/Maximum B, and Maximum A/Maximum B.

Damper testing includes meeting material construction requirements, cycling, temperature degradation, dust loading, salt-spray exposure, leakage, and operation at maximum pressure and velocity.

In testing for temperature degradation, the damper is heated in the closed position for 30 minutes and then cycled to see that it operates as intended. Temperature classifications include 121.1°C, 176.7°C, 232.2°C, etc., in increments of 55.6 kelvins.

Generally, Classes I, II, III, and IV are considered appropriate for smoke control. The class specified should be based on the application requirements. For example, Classes I and II are appropriate for mixed air dampers on systems having return fans. Classes II and III are appropriate for zone dampers where more leakage is acceptable. Classes III and IV are applicable to dampers that always modulate, such as in stairwell pressurization systems.

FIRE DAMPERS

Fire dampers are used in HVAC systems to prevent superheated air, gases, or flames from crossing a fire barrier through an air duct. Fire dampers are usually not used in modulating airflow control applications and are designed for extreme operating environments. Fire dampers are rated in hours of exposure in a specified test environment. Construction and performance of fire dampers (Fig. 11 and 12) is governed by UL Standard 555.

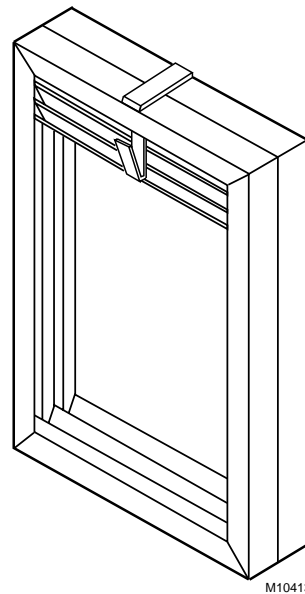

Fig. 11. Wall/Partition Fire Damper.

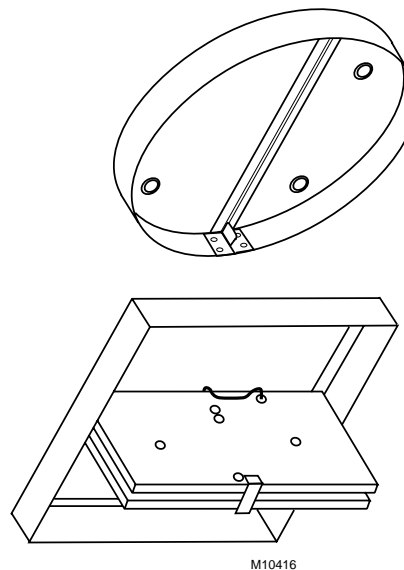

Fig. 12. Ceiling Fire Dampers.

MULTIPLE SECTION DAMPERS

Typically, single rectangular dampers are manufactured in incremental sizes, up to maximum horizontal and vertical limits. If system requirements dictate damper sizes larger than the maximum available, single dampers can be arranged in multiple section assemblies (Fig. 13).

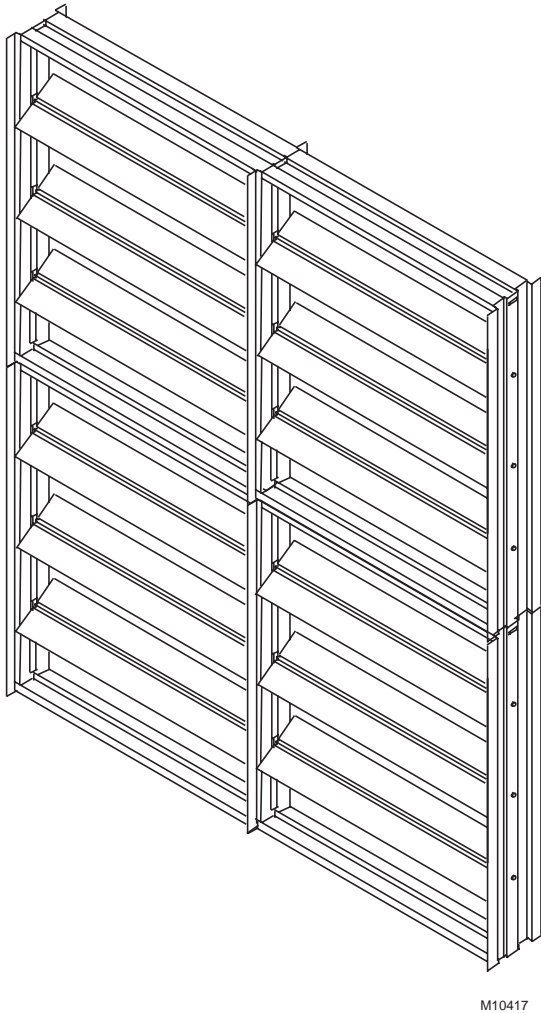

Fig. 13. Multiple Section Damper Assembly.

Multiple section damper assemblies have the drive blades interconnected between sections so all the sections operate in unison. Figures 14 and 15 show methods of connecting drive blades and cross-connecting damper blade linkage for a multiple section damper. As a multiple section damper assembly increases in size, additional precautions are required to withstand pressure drop forces, including:

- Increased bracing at intersecting corners of individual dampers.
- Additional external supports from the damper frame near the center of the assembly to other solid structural members adjacent to the assembly.

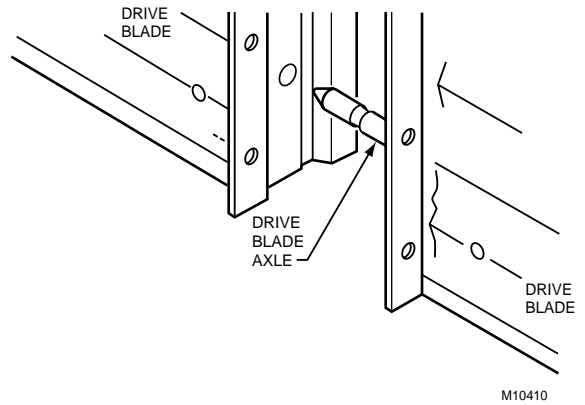

Fig. 14. Drive Blade Axle Extended for Horizontal Multiple Section Damper Assembly.

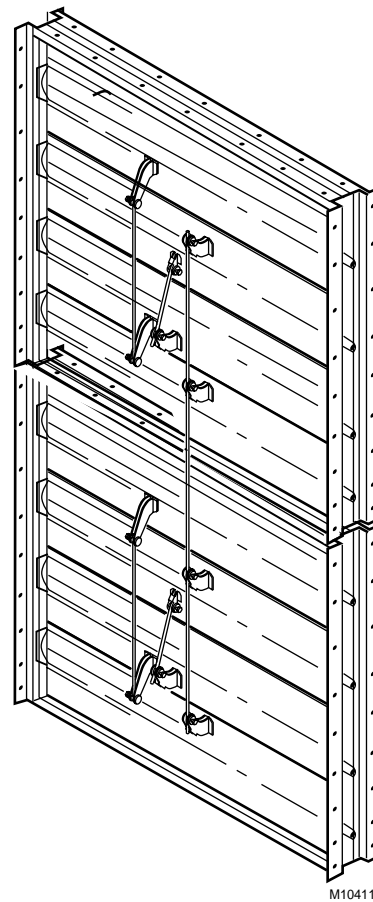

Fig. 15. Drive Blade Linkage for Vertical Multiple Section Damper Assembly.

BAFFLES

System duct sizes do not always correspond with the available sizes of a damper or multiple section damper assembly. In these cases, a baffle is used inside the duct to surround the damper (Fig. 16).

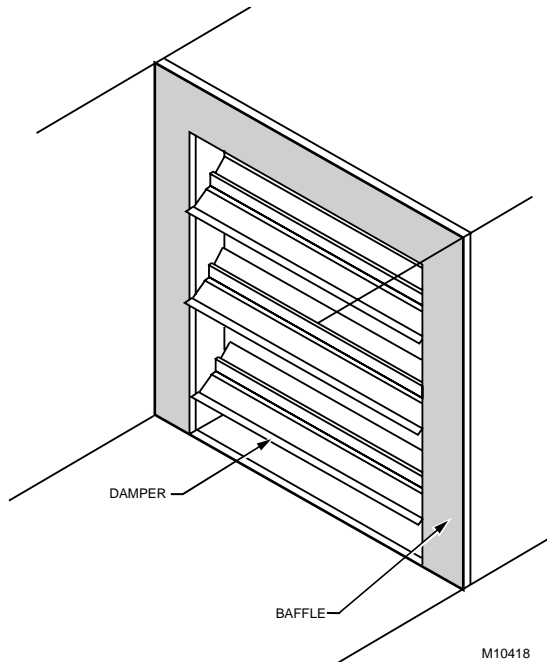

Fig. 16. Baffle Inside Duct Surrounds Damper.

TYPICAL DAMPER CONSTRUCTION

Figure 17 shows construction of an opposed blade damper with linkage. A parallel blade damper is essentially identical except for placement of blade linkage and rotation direction of alternate blades. Higher leakage dampers have either no blade side seals or less effective sealing elements, e.g., adhesive-backed cellular foam strips.

PERFORMANCE DATA

Performance data for dampers can vary in content and form due to the many types of dampers and the philosophies of their manufacturers. When casually compared, performance ratings of different dampers may seem equivalent but are not due to differences in criteria on which the data is based. The following paragraphs discuss the types of performance data and their variations.

LEAKAGE RATINGS

Leakage ratings of dampers are the most widely publicized damper performance data. Figure 18 graphically shows typical leakage performance of dampers with side seals, but without blade edge seals. The torque necessary to achieve the indicated leakage ratings is specified at the top of the graph as 6.0 Nm per square meter of damper area. The wide performance band is explained by the note at the bottom of the graph.

For typical dampers, leakage increases more significantly with the number of blades than with the length of the blades. The data shown applies to a combination of damper heights and widths. For example, a damper 1.22m high x 0.305m wide is the area equivalent of a damper 0.305m. high x 1.22m wide. However, there is significantly more leakage with the 1.2m high x 0.305m wide damper, due to the increased number of blades. Using the leakage performance graph in Figure 18, the range of leakage for these two dampers (0.37 m² each) at 0.249 kPa is:

$$\begin{aligned} \text{Leakage} &= \text{Area} \times \text{Rating}/\text{m}^2 \\ \text{Minimum Leakage} &= 0.37 \times 0.05 \text{ (min)} \\ &= 0.018 \text{ m}^3/\text{s} \\ \text{Maximum Leakage} &= 0.37 \times 0.13 \text{ (max)} \\ &= 0.47 \text{ m}^3/\text{s} \end{aligned}$$

Performance characteristics for low leakage dampers differ from standard dampers. Figure 19 shows typical pressure drop/leakage rating relationship for low leakage dampers. Specific leakage ratings for horizontal (A) and vertical (B) damper dimensions are listed and the torque required has been increased to a flat value for any single section to accommodate light compression blade edge seals.

Using the leakage ratings in Figure 19, the leakage of the two dampers in the previous example at 0.249 kPa is:

$$\begin{aligned} 0.305\text{m (A)} + 1.22\text{m (B)} &= 0.95 \text{ L/s} + 20.5 \text{ L/s} \\ &= 21.45 \text{ L/s} \end{aligned}$$

If the A and B dimensions are reversed, the leakage is as follows:

$$\begin{aligned} 1.22\text{m (A)} + 0.305\text{m (B)} &= 3.4 \text{ L/s} + 6 \text{ L/s} \\ &= 9.4 \text{ L/s} \end{aligned}$$

Other methods of conveying leakage ratings are a tabular format (e.g., leakage per area in m³/s per square meter) and a percentage basis. The tabular format lists specific ratings for each individual damper size. Leakage per area must include sizes of interest. The percentage basis leakage rating is meaningless unless complete conditions including total airflow that the data is based on are also stated.

In many cases, damper data indicates that it is certified by an industry association. Certification means that tests were done under conditions defined by an association of manufacturers but is not a rating by an approval body. For applications other than smoke and fire, there are no approval bodies governing damper leakage or any other performance characteristics.

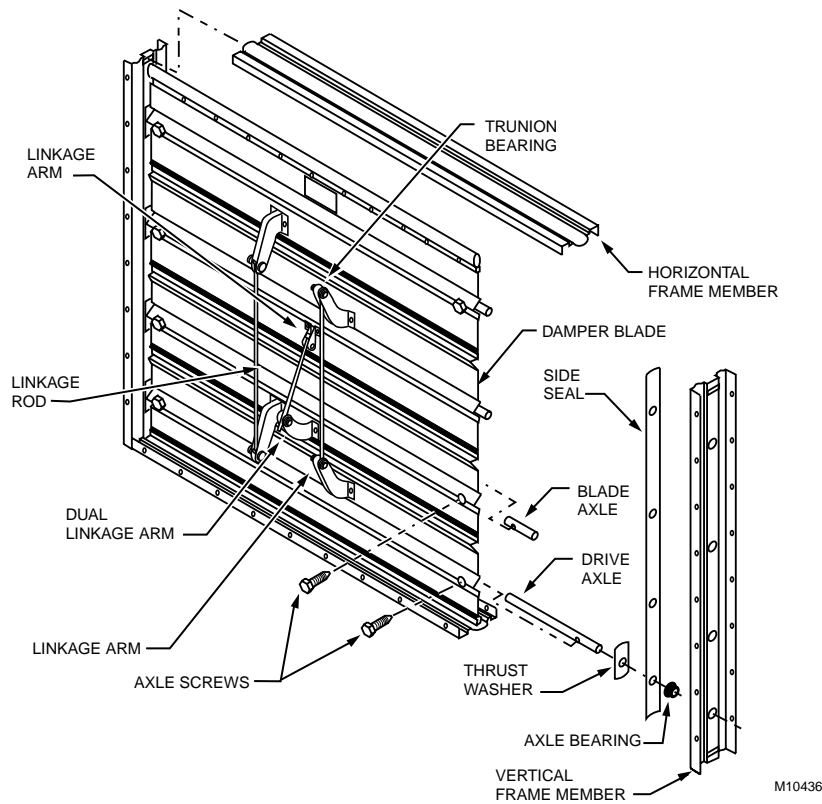

Fig. 17. Typical (Opposed Blade) Damper Construction.

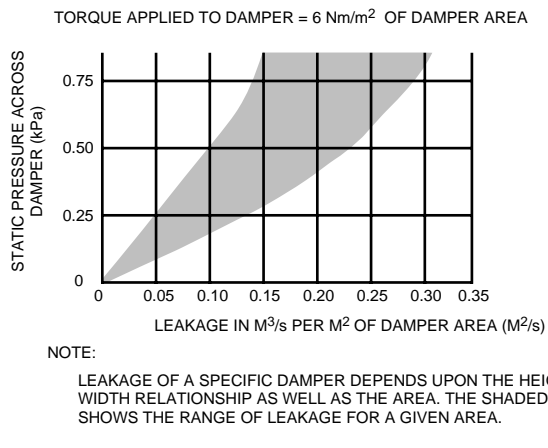

Fig. 18. Graphic Presentation of Leakage Performance.

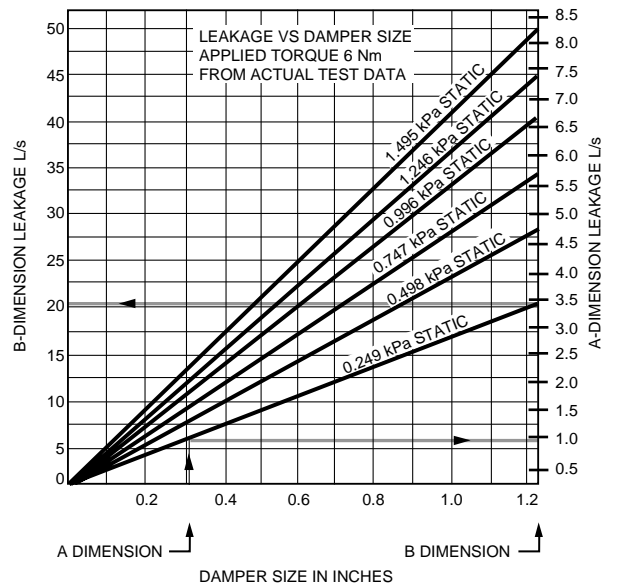

Fig. 19. Low Leakage Dampers.

TORQUE REQUIREMENTS

Operating and close-off torque requirements of dampers and their actuator sizing guidelines are typically shown in manufacturer specifications. Occasionally a brief explanation of the theory or basis for the actuator torque ratings accompanies this data.

Two conditions must be considered when establishing minimum torque requirements of a damper. One is closing torque which is the torque required to force the blades together sufficiently to achieve minimum possible leakage. The other is the dynamic torque required to overcome the effect of high velocity airflow over the blades. The maximum dynamic torque will occur somewhere in the middle two-thirds of the blade rotation depending on the damper design.

VELOCITY RATINGS

Approach velocity of the air is an important physical limitation that applies to all dampers and should be considered when sizing dampers. Generally, the maximum velocity rating increases as the overall performance rating of a damper increases. In practical terms, a higher velocity rating of one damper compared to another indicates the former damper has stiffer blade and linkage design and that the bearings may also be capable of higher loads. The velocity rating of control dampers is usually a statement of the maximum value allowed for the particular design under conditions of normal (not excessive) turbulence. Velocity ratings must be severely reduced under excessively turbulent conditions.

Uneven velocity profiles due to locations near fan discharges, duct transitions, and elbows require derating of the velocity value.

TEMPERATURE RATINGS

The maximum operating temperature of control dampers is the maximum temperature at which they will function normally. Increased temperature ratings on dampers indicate that bearings and seals are constructed of heat resistant materials. Stated temperature limits apply to the operating life that would be expected under normal ambient conditions.

PRESSURE RATINGS

The pressure rating of a control damper is the maximum static pressure differential which may be applied across the assembly when the blades are closed. Excessive leakage (caused by deflection of blades) and abnormally high operating torque (due to forces on blades, and loads on bearings and linkages) can result from high differential pressure. In extreme cases, physical damage to the dampers could occur. Typical ratings are stated in Table 2.

Table 2. Maximum Static Pressure Differential

Damper Type	Pressure Differential (kPa)
Standard Damper	0.75
Standard and High Temperature, Low Leakage Damper	1.50
Low Static, Low Leakage Damper	0.50

The ratings are probably conservative for smaller sizes since damper blades tend to deflect more as their length increases. An alternative method is a listing of differential static capability as a function of damper blade lengths, such as Table 3.

Table 3. Maximum Static Pressure Differential Capability

Damper Length (mm)	Max Close-Off Static (kPa)
305	2.0
610	2.0
915	1.5
1220	1.0

UL CLASSIFICATION (FIRE/SMOKE)

Performance criteria for fire or smoke dampers bearing the UL rating are contained in specifications UL 555 (Standard for Safety/Fire Dampers and Ceiling Dampers) and UL 555S (Standard for Leakage Rated Dampers for Use in Smoke Control Systems). These two specifications govern the design, performance, installation, and marking (labeling) of the devices bearing the UL classification.

APPLICATION ENVIRONMENT

Most HVAC system requirements can be met using standard dampers from major manufacturers. Many manufacturers also build custom dampers with special features to satisfy particular application requirements. Custom features or modifications include blade reinforcement, heavy duty linkage, bearings, axles and frames, special seals, and construction or finish of corrosion resistant materials. The application must be carefully examined to ensure job requirements are met. Some of these special features add significantly to the cost of the damper so they should be furnished only when needed.

VELOCITY

As the velocity in a system increases, dampers in the system encounter higher forces. The impact pressure of the air movement increases the bending force on the damper blades and the airflow over the damper blades may cause a torque or

twist on the blades. Because the blade profile of conventional sheet metal dampers is not streamlined, the stresses imposed on the damper blades due to air movement are dynamic in nature rather than static. To strengthen the damper blades, the gage of metal and the number and depth of longitudinal bends can be increased or reinforcing plates can be spot welded to the blade to increase the blade cross-section. Strengthened dampers also require heavy duty linkage, bearings, and frame. The dynamic and static stresses and linkage and bearing loads all mean that large actuators are needed.

STATIC PRESSURE

The maximum static pressure that an air handling system can develop across a damper occurs when the damper is fully closed. As the damper opens, system airflow increases and a portion of the total pressure is converted to velocity pressure and the forces on the damper become more dynamic than static. It is important to determine the maximum possible static pressure in normal operation and to consider this when selecting dampers.

TEMPERATURE

Some dampers are capable of satisfactory operation in the temperature range of -40 to 200°C , primarily to meet high temperature requirements. A maximum temperature rating of 95°C is usually satisfactory for HVAC use. The specific temperature range for a given damper can be found in the manufacturer specifications.

CORROSION

Dampers used in conventional HVAC systems typically require galvanizing or zinc plating for corrosion protection. Damper applications that may encounter corrosive elements and require additional protection include:

- Buildings in immediate coastal areas where salt spray can enter with the outdoor air.
- Outdoor air applications where the outdoor air damper is located very close to the outdoor air intake, when the outdoor air intake is not protected from rain or snow by fixed louvers, or when the velocity of the outdoor air intake is in the range of 3.8 to 5 m/s or more.
- Face dampers near spray coils.
- Dampers near electronic air cleaners with in-place washers.
- Dampers near spray humidifiers.
- Dampers used in cooling tower applications.
- Dampers in exhaust ducts that carry corrosive fumes or vapors.

All aluminum or all stainless steel construction is preferred in many cases. Optionally, protective finishes are available. The requirement for corrosion resistant dampers usually necessitates a custom built damper.

TURBULENCE

The flow of air in an air handling system is turbulent. Excessive turbulence or pulsations can have the same effects on dampers as increasing air velocity. There is a direct relationship between air velocity and the turbulence caused by airflow through a damper. The effects of moderate turbulence can be noticed on dampers located near abrupt duct transitions or near elbows without turning vanes. Effects of severe turbulence, capable of destroying a damper, can be noticed on dampers located in close proximity to a fan. A damper located near the discharge of a fan should be inspected during actual operation over a full range of positions (from full open to full closed) to be certain no severe vibration occurs (due to the damper being in resonance with a frequency generated by the fan blades). If the damper encounters severe vibration, the vibration may be decreased by adding stiffening members to the damper blades, extra damper linkage, or additional actuators. The preferred method for preventing these damper problems is initial selection of a location with minimal turbulence. However, if high turbulence cannot be avoided, a custom heavy duty damper may be required.

NUCLEAR/SEISMIC APPLICATIONS

Damper applications in nuclear power plants and other similar facilities must be fully compatible with safety system designs and meet all applicable regulations. Some dampers in nuclear facilities are required to operate during and after an earthquake. Seismic or earthquake susceptibility requirements vary and are specific for each individual job or geographic location. Seismic certification involves verification (usually through testing) that the control device can withstand specified levels of vibration. Test procedures include low-frequency, high-amplitude, multiaxial vibration. The tests vary in intensity, not only with different geographic locations but also with the physical elevation within the building. Therefore, test requirements for nuclear facilities must be carefully reviewed to accommodate all applications.

ACTUATORS AND LINKAGES

NORMALLY OPEN/NORMALLY CLOSED

Actuators open and close dampers according to an electric, electronic, or pneumatic signal from a controller. Actuators provide normally open or normally closed damper operation. In a normally closed application, the damper blades are closed

when either no control signal is applied or power to the actuator is lost. The damper blades will open in a normally open application. Selection is based on the desired damper position when power or air is removed from the actuator.

ACTUATOR MOUNTING ALTERNATIVES

Actuators can be installed externally (outside a duct) or internally (inside a duct). See Figures 20 and 21.

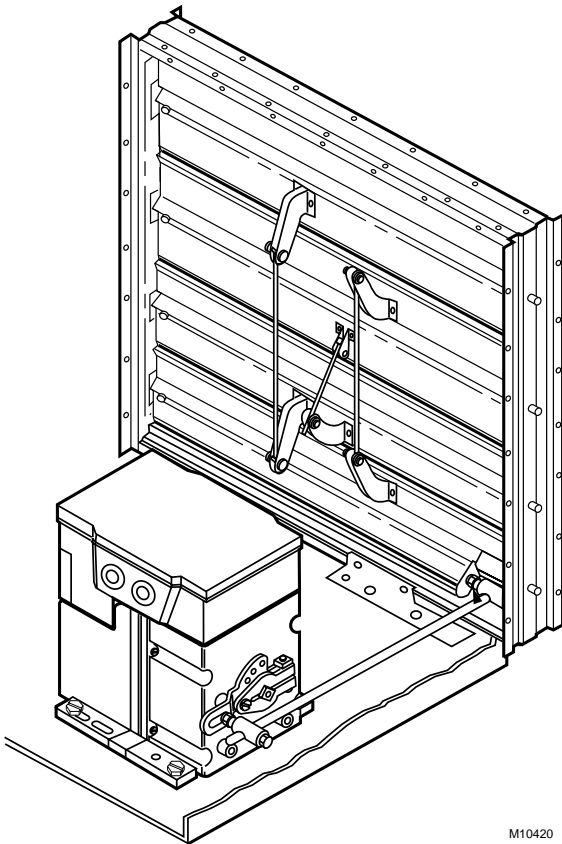

Fig. 20. Internally Mounted Electric Actuator.

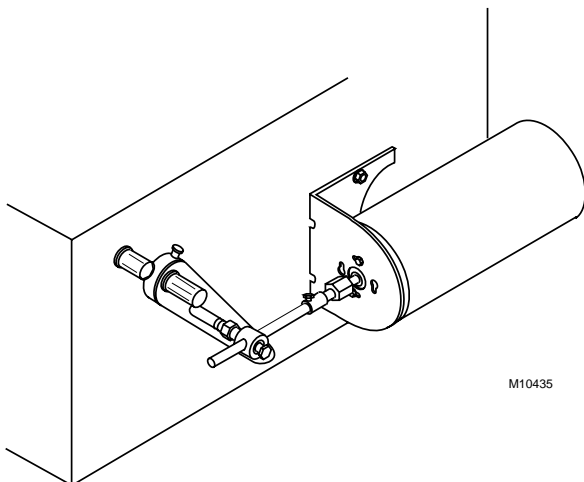

Fig. 21. Externally Mounted Pneumatic Actuator.

POSITIVE POSITIONERS

Some actuators are equipped with position-sensing feedback controls or circuits that are called positive-positioners. The feedback system senses the actuator position, whether rotation or stroke, and compares it to the position dictated by the control signal (input). If some outside force (e.g., friction or torque on damper blades) disturbs the actuator position, the feedback mechanism causes the actuator to correct its position. It also minimizes any effect of hysteresis inherent in the actuator. It is not recommended to use more than one positive positioner per bank of dampers (multiple sections connected together).

MULTIPLE ACTUATORS

Multiple actuators can drive sections of a multiple section damper (Fig. 22) in unison. Multiple sections should be all linked together both in vertical and horizontal stacks. When all sections are linked together, actuators should all have the same operating range, torque, and stroke to prevent damper blade twist and binding.

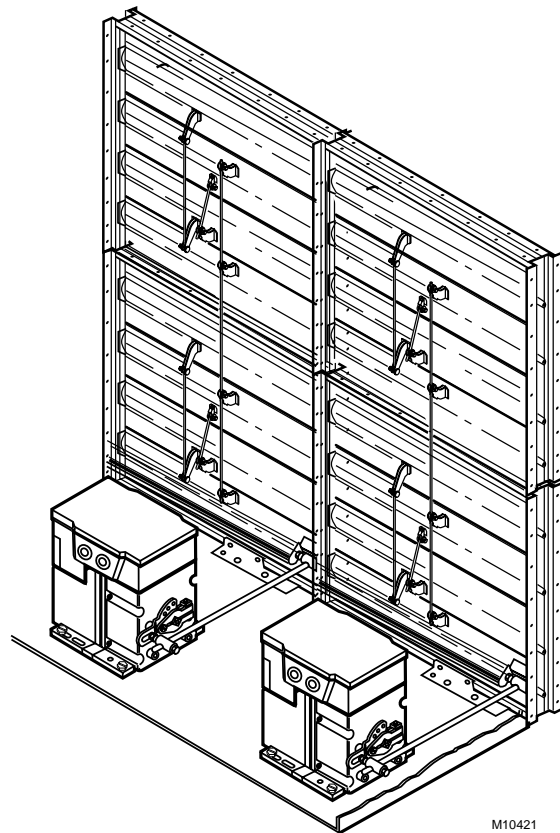

Fig. 22. Control of a Multiple Section Damper.

Multiple actuators can also be used for unison operation of two or more dampers in different locations. All actuators in this arrangement must have the same input signal (e.g., voltage, pressure, current), timing, and stroke to provide uniform opening and closing.

JACKSHAFTS

A jackshaft allows a single actuator to drive adjacent vertical sections of a multiple section damper assembly with evenly distributed force (Fig. 23). It provides adjustability and uniform synchronized section-to-section operation.

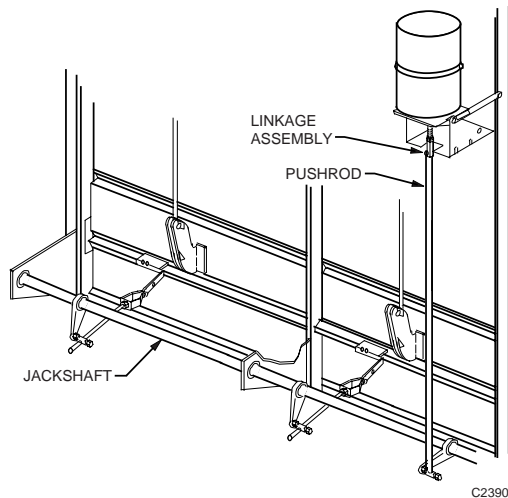

Fig. 23. Damper Jackshaft Application.

DAMPER SIZING

Dampers are typically chosen based on duct size and convenience of location. However, selection by these criteria frequently results in oversized dampers which produce undesirable system control results. Proper selection and sizing of dampers provides the following benefits:

- Lower installation cost because damper sizes are smaller. In addition, smaller actuators or a fewer number of them are required.
- Reduced energy costs because smaller damper size allows less overall leakage.
- Improved control characteristics (rangeability) because the ratio of total damper flow to minimum controllable flow is increased.
- Improved operating characteristics (linearity).

When selecting a damper, it is necessary to consider the operating characteristics and capacities so the desired system control is achieved. These items are discussed, along with damper sizing, in this section.

SYSTEM CHARACTERISTICS

The damper system consists of the damper plus the series resistance that relates to that particular damper (e.g., duct work, mixing boxes, diffusers, and coils).

ACTUATOR SELECTION

One method of selecting actuators for damper applications is based on the number of square meters of damper to be positioned related to a specific actuator. This data is usually provided in tabular form in the manufacturer specifications and is valid for specified static pressure and velocity levels only.

Another method of selecting actuators relates the total blade width dimension of single and multisection dampers to the actuator capability. The ratings of actuators are based on this dimension and are given in tabular form in the manufacturer specifications.

Figure 24 shows a typical control loop for a damper system. The thermostat in the space contains the sensing element and controller. The difference between the control point and setpoint determines the correction signal from the controller. The controller directs the actuator to open or close the damper. The position of the damper determines the volume of the air flowing and ultimately the temperature of the space.

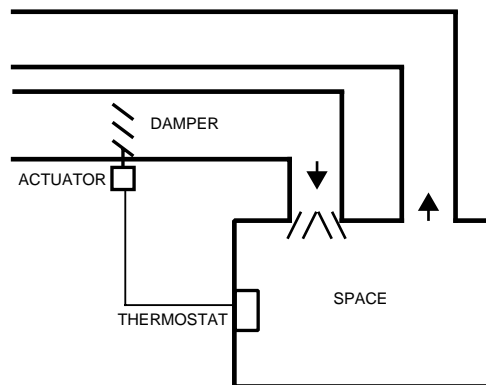

Fig. 24. Control Loop for a Damper System.

DAMPER SELECTION AND SIZING

Stability of space temperature is important in providing a comfortable, energy-efficient environment. The most significant factor in achieving stability of a control loop is the gain of the system elements. The gain of a damper system is the ratio of the change in airflow to the change in signal to the actuator.

In an ideal damper system, the gain is linear over the entire operating range (e.g., a small increase in space temperature results in a small increase in cooling airflow). The more linear the system, the more constant the system gain and the more stable the system operation over its entire range.

DAMPER CHARACTERISTICS

INHERENT CHARACTERISTIC

The relationship between damper blade position and airflow through the damper is defined as the inherent characteristic. The inherent characteristic is defined at a constant pressure drop with no series resistance (coils, filters, louvers, diffusers, or other items).

Figure 25 shows the inherent airflow characteristic curves of parallel and opposed blade dampers. This difference in airflow is important when selecting the proper damper for a system.

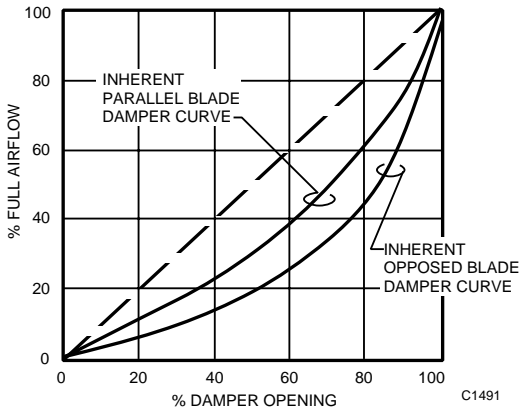

Fig. 25. Parallel versus Opposed Blade Damper Inherent Airflow Characteristic Curves at Constant Pressure Drop.

INSTALLED CHARACTERISTIC

The inherent characteristic is based on a constant pressure drop across the damper. This is frequently not the case in practical applications. Series resistance elements such as duct resistance, coils, and louvers, cause the pressure drop to vary as the damper changes position (Fig. 26 and 27). The resulting installed characteristic (Fig. 28) is determined by the ratio of series resistance elements to damper resistance and will vary for parallel and opposed blade damper.

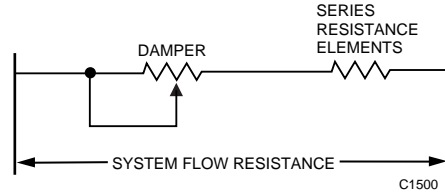

Fig. 26. Resistance to Airflow in Actual System.

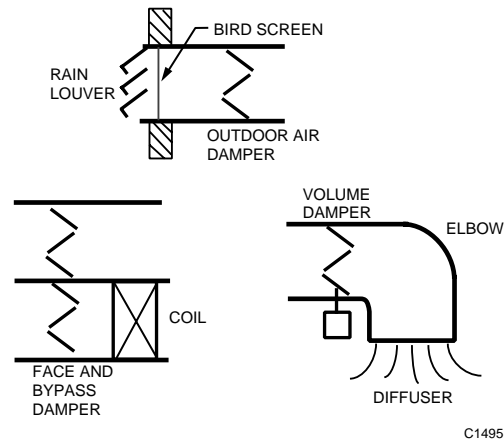

Fig. 27. Examples of Resistance to Airflow.

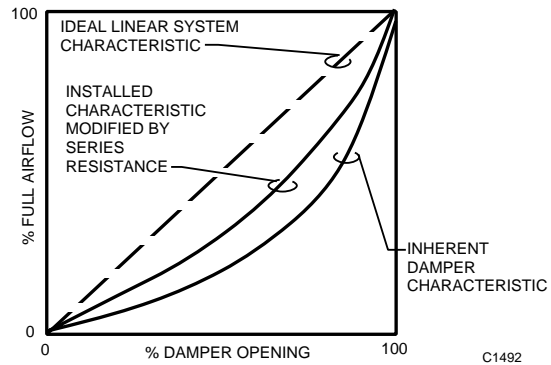

Fig. 28. Installed versus Inherent Airflow Characteristics for a Damper.

Series resistance modifies the damper airflow characteristic. The greater the series resistance, the greater the modification. The ratio of series resistance to damper resistance is called the characteristic ratio. Figures 29 and 30 show modified characteristics for parallel and opposed blade dampers based on various ratios of series resistance to full open damper resistance.

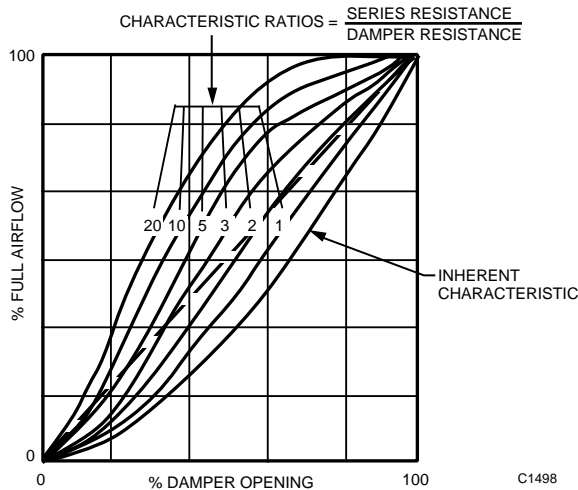

Fig. 29. Damper System Characteristics of Parallel Blade Dampers.

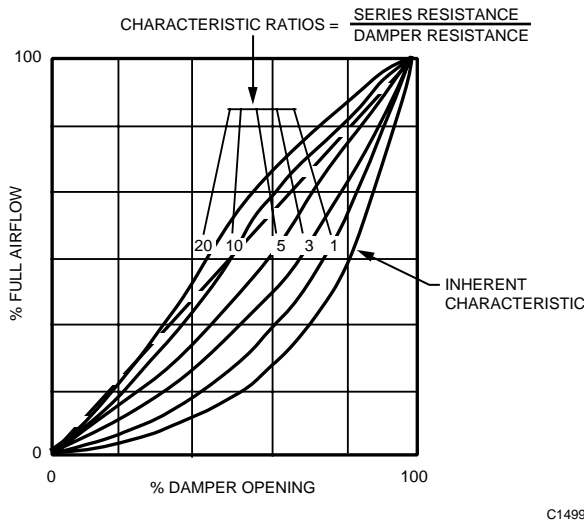

Fig. 30. Damper System Characteristics of Opposed Blade Dampers.

To achieve performance closest to the ideal linear flow characteristic, a characteristic ratio of 2.5 for parallel blade dampers (Fig. 29) and 10 for opposed blade dampers (Fig. 30) should be used. The percent of the total resistance needed by the damper can be determined by:

$$\text{Total resistance (100\%)} = \text{damper resistance} + \text{series resistance}$$

Characteristic ratio

$$(\text{Fig. 29 and 30}) = \frac{\text{series resistance}}{\text{damper resistance}}$$

Substituting (total resistance – damper resistance) for series resistance:

$$\text{Characteristic ratio} = \frac{\text{total resistance} - \text{damper resistance}}{\text{damper resistance}}$$

or

$$= \frac{\text{total resistance}}{\text{damper resistance}} - 1$$

For parallel blade dampers:

$$2.5 = \frac{100}{\text{damper resistance}} - 1$$

Damper resistance = 29% of total resistance

or

$$\frac{29}{100 - 29} = 41\% \text{ of series resistance}$$

For opposed blade dampers:

$$10 = \frac{100}{\text{damper resistance}} - 1$$

or damper resistance = 9% of total resistance

$$\frac{9}{100 - 9} = 10\% \text{ of series resistance}$$

For example, if a coil (Fig. 31) with a pressure drop of 0.140 kPa is located in series with an opposed blade damper, the damper should have a pressure drop of 0.014 kPa (10 percent of 0.140 = 0.014).

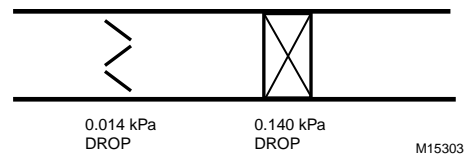

Fig. 31. Typical Pressure Drop for Coil and Damper (Series Resistance).

DETERMINING DAMPER SIZE

The desired relationship of damper resistance to series resistance developed in DAMPER CHARACTERISTICS is used to determine the desired damper pressure drop. This pressure drop is then used in the damper sizing procedure in Table 4.

For example, for a 915 mm by 1625 mm (1.487 m²) duct with an airflow of 9.45 m³/s and a pressure drop of 0.014 kPa across a parallel blade damper, determined the damper size as shown in Table 5.

DAMPER SELECTION AND SIZING

Table 4. Damper Sizing Procedure.

Step	Procedure
1	Calculate the approach velocity: $\text{Approach velocity (m/s)} = \frac{\text{Airflow (L/s)}}{\text{Duct Area (m}^2\text{)}} \times \frac{1 \text{ m}^3}{1000\text{L}}$
2	Using the approach velocity from Step 1, calculate a correction factor: $\text{Correction factor} = \frac{25.8}{[\text{Approach velocity (m/s)}]^2}$
3	Calculate the pressure drop at 5.08 m/s: Pressure drop at 5.08 m/s = Pressure drop at approach velocity x correction factor (Step 2)
4	Calculate free area ratio ^a : For pressure drops (Step 3) \geq 57.1 Pa: Ratio = $[1 + (0.0859 \times \text{pressure drop})]^{-0.3903}$ For pressure drops (Step 3) $<$ 57.1 Pa: Ratio = $[1 + (0.3214 \times \text{pressure drop})]^{-0.2340}$
5	Calculate damper area (m ²): For parallel blade dampers: Damper area (m ²) = (Duct area (m ²) x ratio, x 1.2897) ^{0.9085} For opposed blade dampers: Damper area (m ²) = (Duct area (m ²) x ratio, x 1.4062) ^{0.9217}

^a The free area of a damper is the open portion of the damper through which air flows. The free area ratio is the open area in a damper divided by the total duct area.

Table 5. Damper Sizing Example.

Step	Example
1	$\text{Approach velocity (m/s)} = \frac{9440 \text{ L/s}}{1.485 \text{ m}^2} \times \frac{1 \text{ m}^3}{1000\text{L}} = 6.35 \text{ m/s}$
2	$\text{Correction factor} = \frac{25.8}{16.35} = 0.64$
3	$\text{Pressure drop at 5 m/s} = 14.9 \text{ Pa} \times 0.64 = 9.43 \text{ Pa}$
4	$\begin{aligned} \text{Free area ratio} &= [1 + (0.3214 \times 9.43)]^{-0.2340} \\ &= 3.03^{-0.2340} \\ &= 0.772 \end{aligned}$
5	$\begin{aligned} \text{Damper area (parallel blades)} &= (1.485 \text{ m}^2 \times 0.772 \times 1.2897)^{0.9085} \\ &= 1.3828^{0.9085} \\ &= 1.342 \text{ m}^2 \end{aligned}$

A damper size of 915 mm by 1475 mm (1.350 m²) would be selected for this application since, 915 mm is the largest damper dimension which will fit in the 915 mm width of the duct.

OTHER DAMPER SIZING CONSIDERATIONS

TWO-POSITION CONTROL

1. Typically, duct size parallel blade dampers are selected as they present a lower pressure drop compared to opposed blade dampers of equal size.
2. Check that the damper meets maximum velocity, maximum static pressure, and leakage requirements.

MODULATING CONTROL

1. Determine application requirements and select parallel or opposed blade damper.
2. Check that the damper meets maximum velocity, maximum static pressure, and leakage requirements.

OVERSIZED DAMPER CHARACTERISTICS

DAMPER PERFORMANCE

An oversized damper is one that has a characteristic ratio higher than 2.5 for parallel blade dampers or 10 for opposed blade dampers. The resultant characteristic curve of an oversized damper can be seen in Figures 29 and 30 represented by the high ratio curves. These are well above the ideal linear curve.

The result of oversizing is that a large percentage of the full airflow occurs when the damper is open to only a small percentage of its full rotation.

By using a smaller damper, the percentage of the pressure drop increases across the damper. The performance curve shifts from the oversized curve, through the linear curve, and towards the inherent curve which is based on 100 percent of the system pressure drop across the damper. The oversized damper characteristic is based upon a majority of the system pressure drop being across the series resistance rather than the damper.

The actual curve can approach the linear curve if the proper initial resistance ratio for the damper has been selected. See Figure 32. An oversized parallel blade damper causes a greater deviation from the linear characteristic than an oversized opposed blade damper which can be corrected by selecting a smaller damper to take more of the total pressure drop.

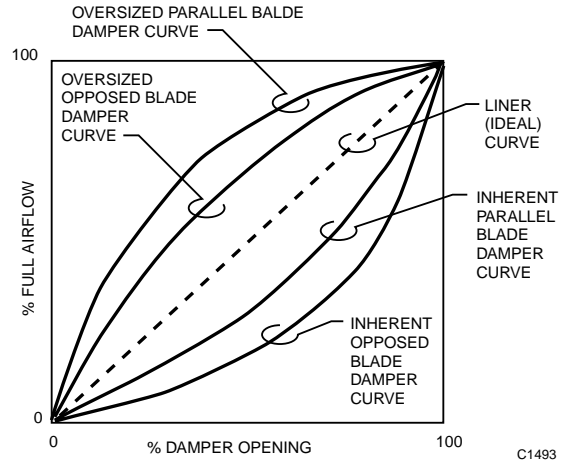

Fig. 32. Comparison of Oversized Parallel versus Oversized Opposed Blade Dampers.

CONTROL SYSTEM SENSITIVITY

An oversized damper with a nonlinear characteristic curve causes the sensitivity of the system to change throughout the damper operating range as shown in Figure 33. The first 50 percent of the opening results in 85 percent of the airflow; the last 50 percent, only 15 percent of the airflow. As the percent damper opening varies, the sensitivities of the system at the associated damper positions are considerably different. Increasing sensitivity can cause the system to hunt or cycle resulting in poor control. As the characteristic curve of the damper becomes more linear, the sensitivity of the system becomes more constant and allows more stable control.

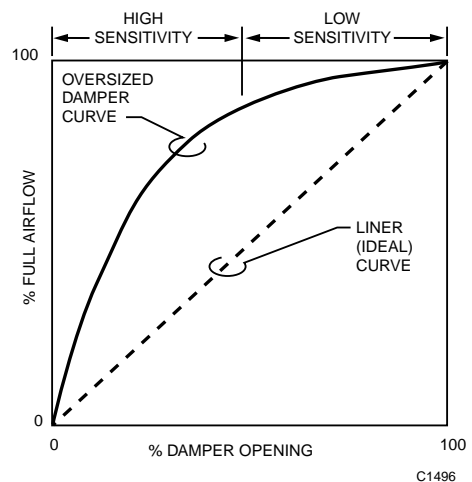

Fig. 33. Effects of Oversized Damper on System Sensitivity.

DAMPER PRESSURE DROP

If the duct size, damper size, and the airflow are known, use the method in Table 6 to determine the actual pressure drop across the damper:

For example, for a 1.50 m² parallel blade damper in a 1.69 m² duct with an airflow of 9.45 m³/s, determine the pressure drop across the damper as shown in Table 7.

Table 6. Damper Pressure Drop Calculation Procedures

Step	Procedure
1	a. Determine the number of sections required. The area of the damper must not exceed the maximum size for a single section. If the damper area exceeds the single section area: b. Divide the area of the damper, the area of the duct, and the airflow by the number of damper sections. c. Use the values from Step b in the following Steps.
2	Calculate the free area ratio ^a : For parallel blade dampers, the free area ratio is found: $\text{Ratio} = (0.0798 \times \text{damper area m}^2) \times 0.1007 \times \frac{\text{Damper area (m}^2\text{)}}{\text{Duct area (m}^2\text{)}}$ For opposed blade dampers, the free area ratio is found: $\text{Ratio} = (0.0180 \times \text{damper area m}^2) \times 0.0849 \times \frac{\text{Damper area (m}^2\text{)}}{\text{Duct area (m}^2\text{)}}$
3	Using the ratio from Step 1, calculate the pressure drop at 5.08 m/s. For ratios ≤ 0.5: $\text{Pressure drop (Pa)} = -11.64 \times (1 - \text{ratio})^{-2.562}$ For ratios > 0.5: $\text{Pressure drop (Pa)} = -3.114 \times (1 - \text{ratio})^{-4.274}$
4	Calculate the approach velocity: $\text{Approach velocity (m}^3\text{/s)} = \frac{\text{Airflow (m}^3\text{/s)}}{\text{Duct Area (m}^2\text{)}}$
5	Using the approach velocity from Step 3, calculate a correction factor: $\text{Correction factor} = \frac{25.8}{[\text{Approach velocity (m/s)}]^2}$
6	Calculate the pressure drop across the damper: $\text{Pressure drop (Pa)} = \frac{\text{Pressure drop (Pa) at 5.08 m/s (Step 2)}}{\text{Correction factor (Step 4)}}$

^a The free area of a damper is the open portion of the damper through which air flows. The free area ratio is the open area in a damper divided by the total duct area.

Table 7. Pressure Drop Calculation Example.

Step	Example
1	Not applicable
2	$\begin{aligned} \text{Free area ratio (parallel blades)} &= (0.0798 \times 1.50 \text{ m}^2) 0.1007 \times \frac{1.50 \text{ m}^2}{1.69 \text{ m}^2} \\ &= 0.8075 \times 0.8876 \\ &= 0.717 \end{aligned}$
3	$\begin{aligned} \text{Pressure drop at 15.08 m/s} &= -3.114 \times (1 - 0.717^{-4.274}) \\ &= -3.114 \times -3.1449 \\ &= 9.783 \text{ Pa} \end{aligned}$
4	$\begin{aligned} \text{Approach velocity} &= \frac{9.45 \text{ m}^3/\text{s}}{1.69 \text{ m}^2} \\ &= 5.59 \text{ m/s} \end{aligned}$
5	$\begin{aligned} \text{Correction factor} &= \frac{25.8}{5.59^2} \\ &= 0.826 \end{aligned}$
6	$\begin{aligned} \text{Pressure drop across damper} &= \frac{9.783 \text{ Pa}}{0.826} \\ &= 11.86 \text{ Pa} \end{aligned}$

Had the duct size been 1.50 m², the same size as the damper, the pressure drop would have been lower (7.25 Pa).

DAMPER APPLICATIONS

The Table 8 indicates the damper types typically used in common control applications.

Table 8. Damper Applications.

Control Application	Damper Type
Return Air	Parallel
Outdoor Air or Exhaust Air (with Weather Louver or Bird Screen)	Opposed
(without Weather Louver or Bird Screen)	Parallel
Coil Face	Opposed
Bypass (with Perforated Baffle)	Opposed
(without Perforated Baffle)	Parallel
Two-Position (all applications)	Parallel

MIXED AIR CONTROL

Figure 34 shows a mixed air control system. All three dampers (outdoor, exhaust, and return air) are the primary source of pressure drop in their individual system so parallel blade dampers are selected to obtain linear control.

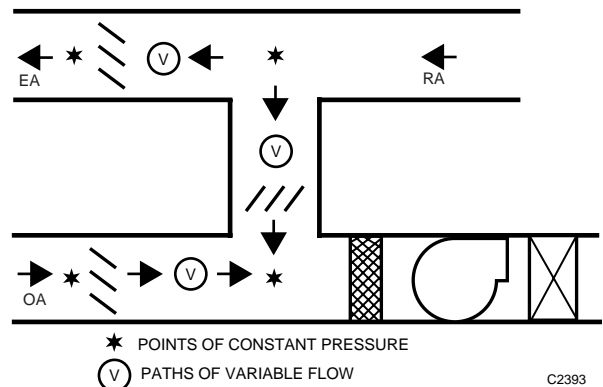

Fig. 34. Mixed Air Control System (Parallel Blade Dampers).

When a weather louver or bird screen is used in series with the outdoor air and exhaust dampers (Fig. 35), the static pressure drop shifts from the louvers/screens to the dampers as they go from open to closed. Opposed blade dampers for outdoor air and exhaust air provide a more linear characteristic for these systems. The return damper is still the primary source of pressure drop in its system so a parallel blade damper is used to minimize pressure drop yet maintain a linear characteristic.

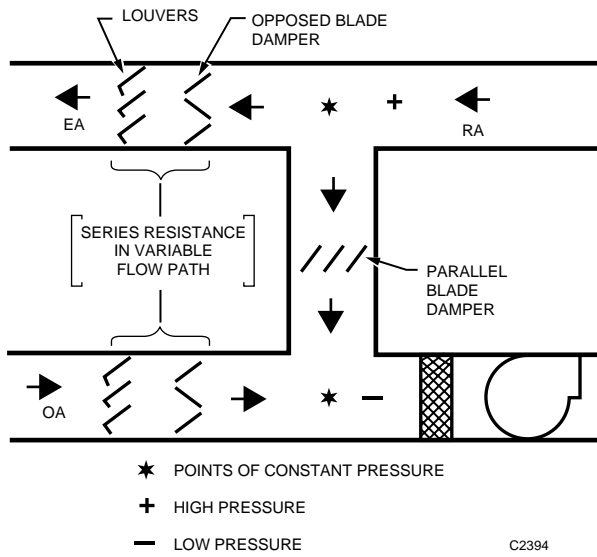

Fig. 35. Mixed Air System with Louvers.

Figure 36 shows correct orientation of parallel blade dampers for effective mixing. Proper orientation helps avoid cold areas in the mixed air stream which could freeze coils.

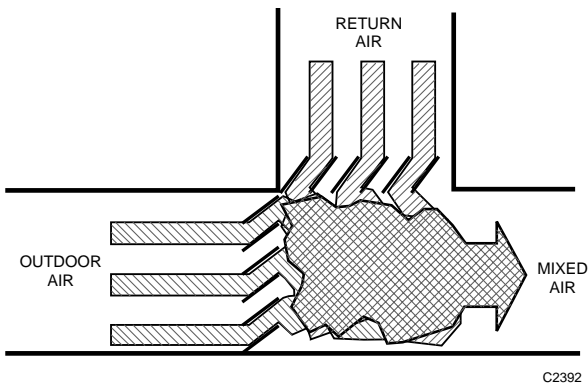

Fig. 36. Parallel Blade Dampers Oriented for Effective Mixing.

FACE AND BYPASS CONTROL

Figure 37 shows a face and bypass damper application. The system pressure drop is relatively constant across the bypass damper so a parallel blade damper is used for minimum pressure drop at full flow. The system pressure drop across the face damper shifts from the coil to the damper as the damper closes so an opposed blade damper is used for more linear control. The face damper should be equal to the coil size to prevent stratification (hot and cold spots) across the coil.

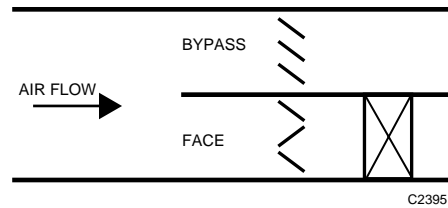

Fig. 37. Face and Bypass Damper Application.

THROTTLING CONTROL

Either parallel or opposed blade dampers can be used for throttling applications. If the primary resistance of the system is the damper, parallel blade dampers are preferred. However, if significant series resistance exists, like a reheat coil, opposed blade dampers should be used.

General Engineering Data

ENGINEERING MANUAL OF AUTOMATIC CONTROL

CONTENTS

Introduction	466
Conversion Formulas and Tables	466
General	466
Metric Prefixes	466
Pressure	466
Weight/Mass	467
Length	467
Area	467
Volume	468
Mass Per Unit Volume of Water	468
Specific Heat	468
Temperature	468
Heat Transfer	470
Velocity	470
Flow	470
Power	471
Work/Energy	471
Enthalpy	472
Force	472
Torque	472
Density	472
Electrical Data	473
Electrical Distribution Systems	473
General	473
Single-Phase System	473
Three-Phase Three-Wire Wye System	474
Three-Phase Four-Wire Wye System	474
Three-Phase Delta System	474
Electric Motors	475
Voltage Conversion	475
Properties of Saturated Steam Data	476
Airflow Data	477
Fan Ratings	477
Velocity Pressure	478
Moisture Content of Air Data	479
Moisture in Compressed Air	479
Relative Humidity	481

INTRODUCTION

This section provides engineering data of a general nature. It is reference information applicable to any or all other sections of the Engineering Manual of Automatic Control.

CONVERSION FORMULAS AND TABLES

GENERAL

The conversion multiplier tables in this section provide conversion factors. When the existing unit is multiplied by the conversion factor, the result is the desired unit.

METRIC PREFIXES

Table 1. Metric Prefixes.

Prefix	Symbol	Conversion Factor	
giga	G	10 ⁹	1,000,000,000
mega	M	10 ⁶	1,000,000
kilo	k	10 ³	1,000
hecto	h	10 ²	100
deca	da	10 ¹	10
deci	d	10 ⁻¹	0.1
centi	c	10 ⁻²	0.01
milli	m	10 ⁻³	0.001
micro	μ	10 ⁻⁶	0.000 001
nano	n	10 ⁻⁹	0.000 000 001

EXAMPLES:

14 kilocalories = 14 x 10³ calories = 14,000 calories

1 milliliter = 1 x 10⁻³ liter = 0.001 liter

PRESSURE

Table 2 lists converted values for psi to kPa using the 6.8948 factor then rounding off to the nearest whole number.

Table 2. Psi to kPa Conversion.

Psi	kPa	Psi	kPa
1	7	16	110
2	14	17	117
3	21	18	124
4	28	19	131
5	34	20	138
6	41	21	145
7	48	22	152
8	55	23	159
9	62	24	165
10	69	25	172
11	76	26	179
12	83	27	186
13	90	28	193
14	97	29	200
15	103	30	207

Table 3. Pressure Conversion Multipliers.

Existing Unit	Desired Unit								
	Pounds per Sq In. (psi)	Kilo-pascals (kPa)	Ounces per Sq In.	Millimeters of Mercury	Kilogram-force per cm ²	Inches of Water	Inches of Mercury	Feet of Water	Bar
Pounds per Sq In. (psi)	—	6.8948	16.0	51.7	0.0703	27.68	2.036	2.307	0.068948
Kilopascals (kPa)	0.1450	—	2.3207	7.503	0.0102	4.014	0.2952	0.3346	0.01
Ounces per Sq In.	0.0625	0.4309	—	3.23	0.004395	1.73	0.127	0.144	0.004309
Millimeters of Mercury	0.0193	0.1333	0.3094	—	0.00136	0.5354	0.0394	0.04461	0.001333
Kilogram-force per cm ²	14.22	98.09	228.0	735.6	—	393.7	28.96	32.81	0.9809
Inches of Water	0.0361	0.2491	0.578	1.865	0.00254	—	0.0735	0.0833	0.002491
Inches of Mercury	0.4912	3.387	7.86	25.4	0.03453	13.60	—	1.133	0.03387
Feet of Water	0.4335	2.989	6.928	22.42	0.0305	12.0	0.8826	—	0.02989
Bar	14.5	100	232.072	750.188	1.0195	401.445	29.525	33.456	—

Absolute Pressure = Gage Pressure + 14.74 psi
 = Gage Pressure + 101.325 kPa.

1 pascal = 1 newton per square meter

EXAMPLE:

24 psi x 6.8948 = 165.48 kilopascals

WEIGHT/MASS**Table 4. Weight/Mass Conversion Multipliers.**

Existing Unit	Desired Unit				
	Grains (gr)	Grams (g)	Kilograms (kg)	Ounces (oz)	Pounds (lb)
Grains (gr)	—	0.0648	0.000065	0.00229	0.000143
Grams (g)	15.432	—	1 000	0.0353	0.00221
Kilograms (kg)	15 432	0.001	—	35.274	2.2046
Ounces (oz) av	437.5	28.35	0.02835	—	0.0625
Pounds (lb)	7 000	453.6	0.4536	16	—

EXAMPLE:

$$10 \text{ pounds} \times 0.4536 = 4.54 \text{ kilograms}$$

LENGTH**Table 5. Length Conversion Multipliers.**

Existing Unit	Desired Unit					
	Inches (in.)	Feet (ft)	Meters (m)	Millimeters (mm)	Miles (mi)	Kilometers (km)
Inches (in.)	—	0.083	0.0254	25.4	0.0000158	0.0000254
Feet (ft)	12	—	0.3048	304.80	0.0001894	0.0003048
Meters (m)	39.37	3.281	—	1 000	0.0006214	0.001
Millimeters (mm)	0.03937	0.003281	0.001	—	0.0000006	0.00001
Miles (mi)	63 360	5 280	1 609.344	1 609 344	—	1.6093
Kilometers (km)	39 370	3 281	1 000	1 000 000	0.6214	—

Centimeters (cm) \times 10 = millimeters (mm)Millimeters (mm) \times 0.1 = centimeters (cm)

Micron = micrometer

EXAMPLE:

$$17 \text{ feet} \times 0.3048 = 5.18 \text{ meters}$$

AREA**Table 6. Area Conversion Multipliers.**

Existing Unit	Desired Unit				
	Sq feet (ft ²)	Sq inches (in ²)	Sq millimeters (mm ²)	Sq meters (m ²)	Sq yards (yd ²)
Sq feet (ft ²)	—	144	92 903	0.0929	0.111
Sq inches (in ²)	0.00694	—	645.2	0.00065	0.00077
Sq millimeters (mm ²)	0.0000108	0.00155	—	0.000001	0.0000012
Sq meters (m ²)	10.764	1 550.0	1 000 000	—	1.196
Sq yards (yd ²)	9.0	1 296	836 127	0.8361	—

Sq miles \times 2.590 = Sq kilometersSq kilometers \times 0.3861 = Sq miles

EXAMPLE:

$$30 \text{ square feet} \times 0.0929 = 2.79 \text{ square meters}$$

VOLUME

Table 7. Volume Conversion Multipliers.

Existing Unit	Desired Unit								
	Cubic inches (in. ³)	Cubic feet (ft ³)	Cubic centimeters (cm ³)	Gallons, US (US gal)	Gallons, Imp (Imp gal)	Liters (L)	Ounces, fluid (oz fluid)	Quarts, liquid (qt liquid)	Cubic meters (m ³)
Cubic inches (in. ³)	—	0.0005787	16.387	0.004329	0.003605	0.016387	0.5541	0.0173	0.0000164
Cubic feet (ft ³)	1728	—	2832	7.481	6.229	28.32	957.5	29.92	0.002832
Cubic centimeters (cm ³)	0.06102	0.0000353	—	0.0002642	0.00022	0.001	0.0338	0.01057	0.000001
Gallons, US (US gal)	231	0.13368	3785.4	—	0.8327	3.7854	128	4	0.003785
Gallons, Imp (Imp gal)	277.42	0.16054	4546	1.2009	—	4.546	153.7	4.803	0.004546
Liters (L)	61.024	0.03531	1 000	0.2642	0.22	—	33.818	1.0568	0.001
Ounces, fluid (oz fluid)	1.805	0.001044	29.58	0.007813	0.0065	0.02957	—	0.03125	0.0000296
Quarts, (qt liquid)	57.75	0.03342	946.4	0.25	0.2082	0.9463	32	—	0.0009463
Cubic meters (m ³)	6 1024	35.31	1 000 000	264.2	220	1 000	33 814	1056.7	—

EXAMPLE:

64 gallons (US) x 3.7854 = 242.27 liters

MASS PER UNIT VOLUME OF WATER

62.383 lb/ft³ or 8.343 lb/gal
 0.999 kg/l or 9.99 g/cm³

SPECIFIC HEAT

Specific heat of water = 1
 Specific heat of steam (water vapor) = 0.49
 Specific heat of air = 0.24

The specific heat of water is the reference for all other substances and means that one Btu will change the temperature of one pound of water one degree Fahrenheit. If a substance has a specific heat of 0.25, then 1/4 Btu will change the temperature of the substance one degree Fahrenheit or one Btu will change the temperature of that substance four degrees Fahrenheit.

Similarly, 4.7 kJ will change the temperature of one kilogram of water one kelvin. If a substance has a specific heat of 0.25, then 4.7 kJ will change the temperature of that substance four kelvins.

EXAMPLE:

1 gpm water at 20F ΔT = 10 000 Btuh
 1 L/s water at 10 kelvins = 1692 kJ per hour

TEMPERATURE

Most temperature conversions will be between Fahrenheit and Celsius (Centigrade) scales. These cannot be done with a simple multiplier. The formulas are:

Temperature in degrees F = 9/5 x degrees C + 32.
 Temperature in degrees C = 5/9 x (degrees F – 32).

Since Fahrenheit and Celsius scales coincide at –40 the following alternate formulas may be used:

Temperature in degrees F = 9/5 x (degrees C + 40) – 40.
 Temperature in degrees C = 5/9 x (degrees F + 40) – 40.

NOTE: A temperature range or span does not require the factors to adjust the zero reference of the temperature scales. A range or span is denoted as Degrees Fahrenheit or Degrees Kelvin (K) and converted as follows:

Degrees F = 9/5 x degrees K
 Degrees K = 5/9 x degrees F

Absolute zero is noted in degrees Rankine (R) or Kelvin. The approximate conversions are:

Degrees R = degrees F + 460.
 Degrees K = degrees C + 273.

Table 8. Celsius/Fahrenheit Conversion Tables.

CELSIUS (CENTIGRADE) TO FAHRENHEIT CONVERSION										
For Temperatures Below 0C										
Temp °C	0	1	2	3	4	5	6	7	8	9
-50	-58.0	59.8	61.6	63.4	65.2	67.0	68.8	70.6	72.4	74.2
-40	-40.0	41.8	43.6	45.4	47.2	49.0	50.8	52.6	54.4	56.2
-30	-22.0	23.8	25.6	27.4	29.2	31.0	32.8	34.6	36.4	38.2
-20	-4.0	-5.8	-7.6	-9.4	-11.2	-13.0	-14.8	-16.6	-18.4	-20.2
-10	+14.0	+12.2	+10.4	+8.6	+6.8	+5.0	+3.2	+1.4	-0.4	-2.2
0	+32.0	+30.2	+28.4	+26.6	+24.8	+23.0	+21.2	+19.4	+17.6	+15.8
For Temperatures Above 0C										
Temp °C	0	1	2	3	4	5	6	7	8	9
0	32.0	33.8	35.6	37.4	39.2	41.0	42.8	44.6	46.4	48.2
10	50.0	51.8	53.6	55.4	57.2	59.0	60.8	62.6	64.4	66.2
20	68.0	69.8	71.6	73.4	75.2	77.0	78.8	80.6	82.4	84.2
30	86.0	87.8	89.6	91.4	93.2	95.0	96.8	98.6	100.4	102.2
40	104.0	105.8	107.6	109.4	111.2	113.0	114.8	116.6	118.4	120.2
50	122.0	123.8	125.6	127.4	129.2	131.0	132.8	134.6	136.4	138.2
60	140.0	141.8	143.6	145.4	147.2	149.0	150.8	152.6	154.4	156.2
70	158.0	159.8	161.6	163.4	165.2	167.0	168.8	170.6	172.4	174.2
80	176.0	177.8	179.6	181.4	183.2	185.0	186.8	188.6	190.4	192.2
90	194.0	195.8	197.6	199.4	201.2	203.0	204.8	206.6	208.4	210.2
100	212.0	213.8	215.6	217.4	219.2	221.0	222.8	224.6	226.4	228.2
110	230.0	231.8	233.6	235.4	237.2	239.0	240.8	242.6	244.4	246.2
120	248.0	249.8	251.6	253.4	255.2	257.0	258.8	260.6	262.4	264.2
FAHRENHEIT TO CELSIUS (CENTIGRADE) CONVERSION										
For Temperatures Below 0F										
Temp °F	0	1	2	3	4	5	6	7	8	9
-50	-45.56	46.11	46.67	47.22	47.78	48.33	48.89	49.44	50.00	50.56
-40	-40.00	40.56	41.11	41.67	42.22	42.78	43.33	43.89	44.44	45.00
-30	-34.44	35.00	35.56	36.11	36.67	37.22	37.78	38.33	38.89	39.44
-20	-28.89	29.44	30.00	30.56	31.11	31.67	32.22	32.78	33.33	33.89
-10	-23.33	3.89	24.44	25.00	25.56	26.11	26.67	27.22	27.78	28.33
0	-17.78	18.332	18.89	19.44	20.00	20.56	21.11	21.67	22.22	22.78
For Temperatures Above 0F										
Temp °F	0	1	2	3	4	5	6	7	8	9
0	-17.78	-17.22	-16.67	-16.11	-15.56	-15.00	-14.44	-13.89	-13.33	-12.78
10	-12.22	-11.67	-11.11	-10.56	-10.00	-9.44	-8.89	-8.33	-7.78	-7.22
20	-6.67	-6.11	-5.56	-5.00	-4.44	-3.89	-3.33	-2.78	-2.22	-1.67
30	-1.11	-0.56	0.00	+0.56	+1.11	+1.67	+2.22	+2.78	+3.33	+3.89
40	+4.44	5.00	5.56	6.11	6.67	7.22	7.78	8.33	8.89	9.44
50	10.00	10.56	11.11	11.67	12.22	12.78	13.33	13.89	14.44	15.00
60	15.56	16.11	16.67	17.22	17.78	18.33	18.89	19.44	20.00	20.56
70	21.11	21.67	22.22	22.78	23.33	23.89	24.44	25.00	25.56	26.11
80	26.67	27.22	27.78	28.33	28.89	29.44	30.00	30.56	31.11	31.67
90	32.22	32.78	33.33	33.89	34.44	35.00	35.56	36.11	36.67	37.22
100	37.78	38.33	38.89	39.44	40.00	40.56	41.11	41.67	42.22	42.78
110	43.33	43.89	44.44	45.00	45.56	46.11	46.67	47.22	47.78	48.33
120	48.89	49.44	50.00	50.56	51.11	51.67	52.22	52.78	53.33	53.89
130	54.44	55.00	55.56	56.11	56.67	57.22	57.78	58.33	58.89	59.44
140	60.00	60.56	61.11	61.67	62.22	62.78	63.33	63.89	64.44	65.00
150	65.56	66.11	66.67	67.22	67.78	68.33	68.89	69.44	70.00	70.56
160	71.11	71.67	72.22	72.78	73.33	73.89	74.44	75.00	75.56	76.11
170	76.67	77.22	77.78	78.33	78.89	79.44	80.00	80.56	81.11	81.67
180	82.22	82.78	83.33	83.89	84.44	85.00	85.56	86.11	86.67	87.22
190	87.78	88.33	88.89	89.44	90.00	90.56	91.11	91.67	92.22	92.78
200	93.33	93.89	94.44	95.00	95.56	96.11	96.67	97.22	97.78	98.33
210	98.89	99.44	100.0	100.6	101.1	101.7	102.2	102.8	103.3	103.9
220	104.4	105.0	105.6	106.1	106.7	107.2	107.8	108.3	108.9	109.4
230	110.0	110.6	111.1	111.7	112.2	112.8	113.3	113.9	114.4	115.0
240	115.6	116.1	116.7	117.2	117.8	118.3	118.9	119.4	120.0	120.6
250	121.1	121.7	122.2	122.8	123.3	123.9	124.4	125.0	125.6	126.1

EXAMPLE:
74F = 23.33C

HEAT TRANSFER

Table 9. Coefficient of Heat Transfer Conversion Multipliers.

Existing Unit	Desired Unit	
	Btu hr•sq ft•°F	Kcal hr•sq m•°C
Btu/hr•sq ft•°F	—	4.88
Kcal/hr•sq m•°C	0.205	—

EXAMPLE:

$300 \text{ Kcal/hr}\cdot\text{sq m}\cdot\text{°C} \times 0.205 = 61.5 \text{ Btu/hr}\cdot\text{sq ft}\cdot\text{°F}$

VELOCITY

Table 10. Velocity Conversion Multipliers.

Existing Unit	Desired Unit			
	Feet per minute (ft/min)	Feet per second (ft/s)	Meters per minute (m/min)	Meters per second (m/s)
Feet per minute (ft/min)	—	0.016667	0.3048	0.00508
Feet per second (ft/s)	60	—	18.2882	0.3048
Meters per minute (m/min)	3.281	0.05468	—	0.016667
Meters per second (m/s)	196.8	3.281	60	—

EXAMPLE:

$950 \text{ feet per minute} \times 0.00508 = 4.83 \text{ meters per second}$

FLOW

Table 11. Flow (Gas/Air) Conversion Multipliers.

Existing Unit	Desired Unit			
	Cubic Feet per minute (cfm)	Cubic Feet per seconds (cfs)	Cubic Meters per second (m ³ /s)	Liters per second (L/s)
Cubic Feet per minute (cfm)	—	0.016667	0.0004719	0.4719
Cubic Feet per second (cfs)	60	—	0.02832	28.32
Cubic meters per second (m ³ /s)	2119	35.31	—	1000
Liters per second (L/s)	2.119	0.03531	0.001	—

EXAMPLE:

$900 \text{ cubic feet per minute} \times 0.4719 = 424.71 \text{ liters per second}$

Table 12. Flow (Liquid) Conversion Multipliers.

Existing Unit	Desired Unit						
	Cubic feet per minute (cfm)	Gallons US per minute (gpm)	Gallons Imp per minute (gpm)	Liters per hour (L/h)	Liter per second (L/s)	Cubic meters per hour (m ³ /h)	Cubic meters per second (m ³ /s)
Cubic feet per minute (cfm)	—	7.482	6.23	1699.0	0.4719	1.6992	0.0004719
Gallons US per minute (gpm)	0.13368	—	0.8327	227.1	0.06309	0.2271	0.0000631
Gallons Imp per minute (gpm)	0.1605	1.20095	—	272.8	0.07577	0.27274	0.0000758
Liters per hour (L/h)	0.0005886	0.0044	0.00367	—	0.002778	0.001	0.0000003
Liters per second (L/s)	2.119	15.85	13.20	3 600	—	3.6	0.001
Cubic meters per hour (m ³ /h)	0.5886	4.4028	3.666	1 000	0.2778	—	0.0002778
Cubic meters per second (m ³ /s)	2118.9	15850	13 198.2	3 600 000	1 000	3599.7	—

1 gpm water at 20F ΔT = 10 000 Btuh

EXAMPLE:

$84 \text{ US gallons per minute} \times 3.785 = 317.94 \text{ liters per minute}$

POWER

Table 13. Power Conversion Multipliers.

Existing Unit	Desired Unit							
	British Thermal Unit/Hour (Btuh)	British Thermal Unit/Minute (Btu/min)	Foot Pounds/Minute (ft-lb/min)	Foot Pounds/Second (ft-lb/s)	Horsepower (hp)	Boiler Horsepower (hp boiler)	Tons of Refrigeration	Kilo-watts (kW)
British Thermal Unit/Hour (btuh)	—	0.01667	12.96	0.2162	0.00039	0.000298	0.000083	0.0002929
British Thermal Unit/Minute (Btu/min)	60	—	776.2	12.96	0.02356	0.00179	0.005	0.01757
Foot Pounds/Minute (ft-lb/min)	0.07716	0.001286	—	0.01667	0.00003	0.0000023	0.0000064	0.0000226
Foot Pounds/Second (ft-lb/s)	4.626	0.0771	60	—	0.00182	0.000138	0.000386	0.00136
Horsepower (hp)	2546.4	42.44	33 000	550	—	0.07605	0.2121	0.7457
Boiler Horsepower (hp boiler)	33520	558.7	433 880	7231	13.15	—	2.793	9.803
Tons of Refrigeration	12000	200.0	155 640	2594	4.715	0.358	—	3.516
Kilowatts (kW)	3414.2	56.92	44 260	737.6	1.341	0.1020	0.2844	—

EXAMPLE:

$$15,000 \text{ Btuh} \times 0.0002929 = 4.3935 \text{ kW}$$

WORK/ENERGY

Table 14. Work/Energy Conversion Multipliers. Energy/Work Conversion Multipliers

Existing Unit	Desired Unit					
	British Thermal Unit (Btuh) (15.6C)	Watt-hour (Wh)	Kilowatt-hour (kWh)	Calorie (Cal)	Foot-pound (ft-lb) ^a	Joule (J)
British Thermal Unit (Btuh) (15.6C)	—	0.2931	0.0002931	252	778.2	1055
Watt-hour (Wh)	3.412	—	0.001	860	2656	3600
Kilowatt-hour (kWh)	3412	1000	—	860 000	2 656 000	3 600 000
Calorie (Cal)	0.00397	0.001163	0.0000012	—	3.085	4.184
Foot-pound (ft-lb) ^a	0.001286	0.0003765	0.00000038	0.3241	—	1.353
Joule (J)	0.0009479	0.0002778	0.0000003	0.2390	0.7393	—

Therm = a quantity of gas containing 100 000 Btu.

^a A foot-pound (ft-lb) is the I-P unit of work or mechanical energy which has the potential to do work. One ft-lb is the work required to raise a weight of one pound one foot or the potential energy possessed by that weight after being raised in reference to its former position. See TORQUE for pound-foot.

EXAMPLE:

$$45 \text{ Btu} \times 252 = 11,340 \text{ calories}$$

ENTHALPY

Btu per lb of dry air x 2.3258 = kJ per kg of dry air
 kJ per kg of dry air x 0.42996 = Btu per lb of dry air

FORCE

Table 15. Force Conversion Multipliers.

Existing Unit	Desired Unit			
	Pound force (lbf)	Gram force (gf)	Kilogram force (kgf)	Newton (N)
Pound force (lbf)	—	453.6	0.4536	4.447
Gram force (gf)	0.0022	—	0.001	0.009807
Kilogram force (kgf)	2.2046	1000	—	9.807
Newton (N)	0.22487	101.97	0.10197	—

EXAMPLE:

15 lbf x 4.448 = 66.72 newtons

TORQUE

Table 16. Torque Conversion Multipliers.

Existing Unit	Desired Unit				
	Kilogram Force Meter (kgf-m)	Ounce Force Inch (ozf-in.) ^a	Pound Force Foot (lbf-ft) ^a	Pound Force Inch (lbf-in.) ^a	Newton Meter (Nm)
Kilogram Force Meter (kgf-m)	—	1388.7	7.2329	86.795	9.8067
Ounce Force Inch (Ozf-in.) ^a	0.00072	—	0.00521	0.0625	0.0070618
Pound Force Foot (lbf-ft) ^a	0.138257	192.0	—	12.0	1.3557
Pound Force Inch (lbf-in.) ^a	0.01152	16.0	0.0833	—	0.1130
Newton Meter (Nm)	0.10197	141.61	0.7376	8.850	—

^a Torque is a turning effort caused by a force acting normal to a radius at a set distance from the axis of rotation. The I-P unit of torque is pound-foot (lbf-ft) or ounce-inch (Ozf-in.). One lbf-ft is equal to one pound acting at one foot from the axis of rotation. See WORK/ENERGY for foot-pound.

EXAMPLE:

25 lbf-in. x 0.1130 = 2.83 newton meter

DENSITY

Table 17. Density Conversion Multipliers.

Existing Unit	Desired Unit			
	Pounds per cubic foot (lb/ft ³)	Pounds per gallon (lb/gal)	Grams per cubic centimeter (g/cm ³)	Kilograms per cubic meter (kg/m ³)
Pounds per cubic foot (lb/ft ³)	—	0.13368	0.016018	16.0185
Pounds per gallon (lb/gal)	7.48055	—	0.119827	119.827
Grams per cubic centimeter (g/cm ³)	62.428	8.34538	—	1000
Kilograms per cubic meter (kg/m ³)	0.062428	0.008345	0.001	—

EXAMPLE:

8 pounds per cubic foot x 16.0185 = 128.15 kilograms per cubic meter

ELECTRICAL DATA

ELECTRICAL DISTRIBUTION SYSTEMS

GENERAL

Power distribution systems use alternating current (ac) where the current and voltage reverse each cycle. Voltage and current follow a sine wave curve (Fig. 1) and go through zero twice each cycle. The two most common frequencies are 60 Hertz (cycles per second) and 50 Hertz.

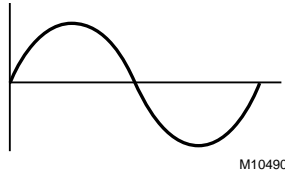

Fig. 1. Sine Wave Curve for Single-Phase Alternating Current and Voltage.

Both a voltage and a current flow are required to provide power. When power is supplied to a pure resistance load (electric heating element or incandescent light bulb) the current is in phase with the voltage. When power is supplied to a reactive load, either capacitive (capacitors) or inductive (motor, solenoid, or fluorescent light), the current is out of phase with the voltage by some angle called θ . The actual power delivered to the device equals the power times $\text{Cos}\theta$. Since the angle θ is not readily available or easy to use, manufacturers often provide a value on the nameplate called power factor (PF). PF will be used in this discussion.

Current lags voltage in inductive loads and leads voltage in capacitive loads. For the same power, a load having a low PF draws more current than a load having a PF of one, requires heavier wires to connect the load, and may result in a higher utility cost. For these reasons capacitors are often added to balance the inductance of motor and fluorescent light loads and bring the PF closer to one.

Power distributed to a load is either single-phase or three-phase. The systems for small loads are usually single-phase. The systems for heavy loads are usually three-phase. Three-phase systems are three single-phase circuits arranged such that each phase reaches its peak at a different time (Fig. 2). The resultant total power is steadier than single-phase power. A three-phase distribution system may be connected in a three- or four-wire wye configuration or a three-wire delta configuration.

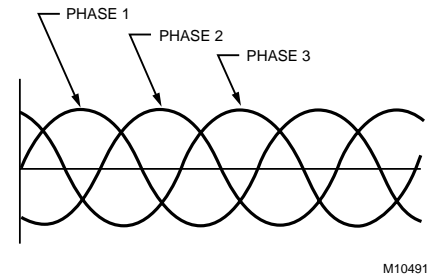

Fig. 2. Sine Wave Curves for Three-Phase Alternating Current and Voltage.

Three-phase distribution is the standard method of power distribution from the generating plant and requires approximately one-fourth less copper than a single-phase system to deliver the same power. Power leaves the generating source on high voltage distribution lines. The voltage is then reduced at the point of usage via transformers.

SINGLE-PHASE SYSTEM

Figure 3 shows a typical single-phase power source. The primary side of the transformer (460V) is usually supplied from one phase of a three-phase distribution system. The secondary side of the transformer has a center tap so it can supply both 115 and 230 volts.

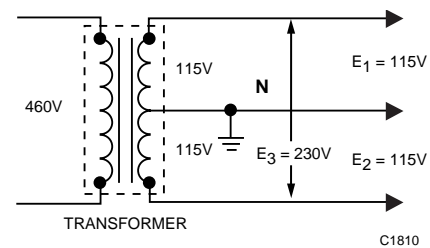

Fig. 3. Single-Phase Transformer.

When PF (power factor) = 1:
The power delivered to the load is:
 $P = EI$

Where:
P = power in watts
E = voltage in volts
I = current in amperes

When PF < 1 the power delivered to the load is:
 $P = EI \times \text{PF}$

THREE-PHASE THREE-WIRE WYE SYSTEM

The line voltage of a three-phase three-wire wye connected system (Fig. 4) is equal to $\sqrt{3}$ times the voltage across the secondary coils of the transformer. In Figure 4, $277V \times \sqrt{3} = 480V$. Notice that in a three-wire wye system the 277V component is not available for use (see THREE-PHASE FOUR-WIRE WYE SYSTEM).

The current through the secondary coils of the transformer is equal to the line current.

This system is most often used for motors and sometimes for electric resistance heaters.

The power formulas for three-phase three-wire wye connected systems are:

Phase/Power Factor	Coil P=	System P=
PF = 1	$3E_{coil} I_{coil}$	$\sqrt{3}E_{line} I_{line}$
PF < 1	$3E_{coil} I_{coil} PF$	$\sqrt{3}E_{line} I_{line} PF$

NOTE: The system power equations assume that the power and therefore the current on each phase is equal. If not, the power is calculated for each phase (coil) and added to get the total power.

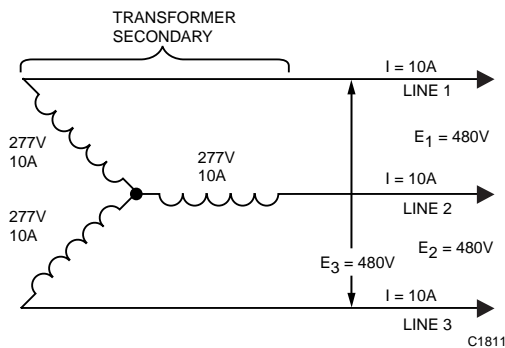

Fig. 4. Three-Phase Three-Wire Wye Connected Transformer.

THREE-PHASE FOUR-WIRE WYE SYSTEM

A three-phase four-wire wye connected system (Fig. 5) adds a wire connected to the common point of the three transformer windings. This provides three single-phase voltages between conductors A, B, or C and N (neutral), that is, the coil voltages are now available. Conductors A, B, and C provide three-phase power for heavier loads. The single-phase power is the same as described in SINGLE-PHASE and the three-phase power is the same as described in THREE-PHASE THREE-WIRE WYE SYSTEM.

The total power is the sum of the power in the three coils.

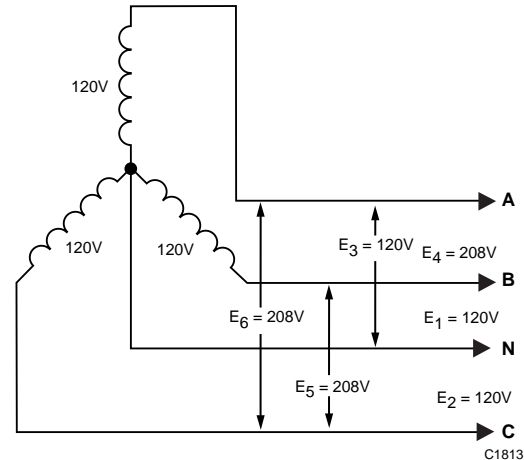

Fig. 5. Three-Phase Four-Wire Wye Connected Transformer.

THREE-PHASE DELTA SYSTEM

The line voltage of a three-phase delta connected system (Fig. 6) is equal to the voltage on the secondary coils of the transformer.

The line current is equal to $\sqrt{3}$ times the coil current.

The power formulas for three-phase delta connected systems are:

Phase/Power Factor	Coil P=	System P=
PF = 1	$3E_{coil} I_{coil}$	$\sqrt{3}E_{line} I_{line}$
PF < 1	$3E_{coil} I_{coil} PF$	$\sqrt{3}E_{line} I_{line} PF$

NOTE: The system power equations assume that the power and therefore the current on each phase is equal. If not, the power is calculated for each phase (coil) and added to get the total power.

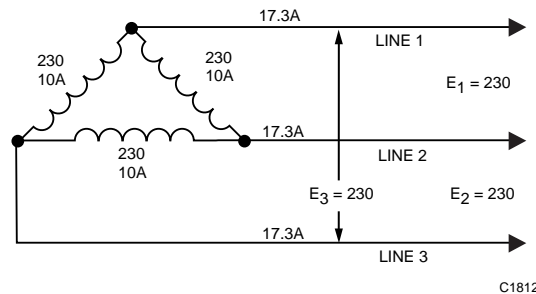

Fig. 6. Three-Phase Delta Connected Transformer.

ELECTRIC MOTORS

Single-phase electric motors are classified by the method used to start the motor. Table 18 describes the characteristics and typical applications of single-phase motors by classification. No special means of starting is required for three-phase motors, since starting (rotational) torque is inherent in three-phase motors. A three-phase motor can be reversed by switching any two phases.

Motors have two current ratings locked rotor (LRA) and full load (FLA). Locked rotor current is drawn at the instant power is applied and before the motor starts rotating. It is also drawn if the motor is stalled. Full load current is drawn when the motor is running at its full load rating.

Table 18. Single-Phase Motor Characteristics and Applications.

Motor Type	Characteristics	Application
Universal (Series)	Armature and field connected in series. Operates on dc or ac with approximately the same speed and torque.	Where either ac or dc may be available. Used for portable tools, vacuum cleaners, electric typewriters, etc.
Split-Phase Starting	Uses a pair of field windings for starting with one winding slightly lagging. One winding is disconnected by a centrifugal switch when running speed is reached.	Where starting torque and varying load are not excessive. Used for oil burners, washing machines, grinding wheels, etc.
Capacitor Starting	Same as split-phase with a capacitor connected to the winding that stays on line. Provides greater starting torque with high efficiency and power factor.	Where high starting torque and heavy varying loads exist. Used for air conditioners, refrigerators, air compressors, etc.
Shaded-Pole Starting	A short-circuited winding is used on each pole piece along with a normal winding. Magnetic flux in the shorted turn produces starting torque. Torque is low.	Where starting torque is low and less than 1/20 horsepower is required. Used for electric clocks.
Repulsion Starting	Operates as a repulsion motor on starting and a centrifugal switch converts it to an induction motor when running speed is reached. Motor has a commutator as in a dc motor. Provides high starting torque.	Where high starting torque is required. Used in machine shops.

VOLTAGE CONVERSION

Table 19. Voltage Conversion Multipliers.

Existing Voltage	Desired Voltage			
	EMS Effective	Average	Peak	Peak-to-Peak
EMS Effective	—	0.900	1.414	2.828
Average	1.110	—	1.570	3.141
Peak	0.707	0.637	—	2.000
Peak-to-Peak	0.354	0.318	0.500	—

PROPERTIES OF SATURATED STEAM DATA

Table 20. Properties of Saturated Steam.

Pressure in kPa (absolute)	Boiling Point or Steam Temperature °C	Specific Volume (V), m ³ /kg	\sqrt{V} (For valve sizing)	Maximum Allowable Pressure Drop, kPa. (For valve sizing)	Heat of the Liquid, kJ/kg	Latent Heat of Evap., kJ/kg	Total Heat of Steam, kJ/kg
1	6.98	129.20	11.3667	0.5	29.34	2485.0	2514.4
5	32.90	28.19	5.3094	2.5	137.77	2423.8	2561.6
10	45.83	14.67	3.8301	5.0	191.83	2392.9	2584.8
50	81.35	3.240	1.8000	25.0	340.56	2305.4	2646.0
60	85.95	2.732	1.6529	30.0	359.93	2293.6	2653.6
70	89.96	2.365	1.5379	35.0	376.77	2283.3	2660.1
80	93.51	2.087	1.4446	40.0	391.72	2274.0	2665.8
90	96.71	1.869	1.3671	45.0	405.21	2265.6	2670.9
100	99.63	1.694	1.3015	50.0	417.51	2257.9	2675.4
101.3	100.00	1.673	1.2934	50.7	419.06	2256.9	2676.0
150	111.37	1.159	1.0766	75.0	467.13	2693.4	2693.4
200	120.23	0.8854	0.9410	100.0	504.70	2706.3	2706.3
250	127.43	0.7184	0.8486	125.0	535.34	2716.4	2716.4
300	133.54	0.6056	0.7782	150.0	561.43	2724.7	2724.7
350	138.87	0.5240	0.7239	175.0	584.27	2731.6	2731.6
400	143.62	0.4622	0.6799	200.0	604.67	2737.6	2737.6
450	147.92	0.4138	0.6433	225.0	623.16	2742.9	2742.9
500	151.84	0.3747	0.6121	250.0	640.12	2747.5	2747.5
600	158.84	0.3155	0.5617	300.0	670.42	2755.5	2755.5
700	164.96	0.2727	0.5222	700.0	697.06	2762.0	2762.0
800	170.41	0.2403	0.4902	400.0	720.94	2667.5	2667.5
900	175.36	0.2148	0.4635	450.0	742.64	2772.1	2772.1
1000	179.88	0.1943	0.4408	500.0	762.61	2776.2	2776.2
1100	184.07	0.1774	0.4212	550.0	781.13	2779.7	2779.7
1200	187.96	0.1632	0.4040	600.0	798.43	2782.7	2782.7
1300	191.61	0.1511	0.3887	650.0	814.70	2785.4	2785.4
1400	195.04	0.1407	0.3751	700.0	830.08	2787.8	2787.8
1500	198.29	0.1317	0.3629	750.0	844.67	2789.9	2789.9
1600	201.37	0.1237	0.3517	800.0	858.56	2791.7	2791.7
1700	204.31	0.1166	0.3415	850.0	871.84	2793.4	2793.4
1800	207.11	0.1103	0.3321	900.0	884.58	2794.8	2794.8
1900	209.80	0.1047	0.3236	950.0	896.81	2796.1	2796.1
2000	212.37	0.09954	0.3155	1000.0	908.59	2797.2	2797.2
2500	223.94	0.07991	0.2827	1250.0	961.96	2800.9	2800.9
3000	233.84	0.06663	0.2581	1500.0	1008.4	2802.3	2802.3
4000	250.33	0.04975	0.2230	2000.0	1087.4	2800.3	2800.3
5000	263.91	0.03943	0.1986	2500.0	1154.5	2794.2	2794.2
6000	275.55	0.03244	0.1801	3000.0	1213.7	2785.0	2785.0
7000	285.79	0.02737	0.1654	3500.0	1267.4	2773.5	2773.5
8000	294.97	0.02353	0.1534	4000.0	1317.1	2759.9	2759.9
9000	303.31	0.02050	0.1432	4500.0	1363.7	2744.6	2744.6
10000	310.96	0.01804	0.1343	5000.0	1408.0	2727.7	2727.7
11000	318.05	0.01601	0.1265	5500.0	1450.6	2709.3	2709.3
12000	324.65	0.01428	0.1195	6000.0	1491.8	2689.2	2689.2
13000	330.83	0.01280	0.1131	6500.0	1532.0	2667.0	2667.0
14000	336.64	0.01150	0.1072	7000.0	1571.6	2642.4	2642.4
15000	342.13	0.01034	0.1017	7500.0	1611.0	2615.0	2615.0
20000	365.70	0.00588	0.0767	10000.0	1826.5	2418.4	2418.4
22000	373.69	0.00373	0.0611	11000.0	2011.1	2195.	2195.6

AIRFLOW DATA

FAN RATINGS

Fans are rated at standard conditions of air: 1.2041 kg/m³ and 20°C at sea level. Therefore, pressures corrected to standard conditions must be used when selecting fans from fan rating tables or curves. Table 21 gives correction factors.

Pressure at operating conditions x factor = pressure at standard conditions.

Horsepower at standard conditions ÷ factor = horsepower required at operating conditions

CAUTION: Size motor for highest density (lowest factor) condition at which it is expected to operate.

Table 21. Altitude and Temperature Correction Factors.

Temp °C	Altitude (m) with Barometric Pressure (kPa)												
	m kPa	0 101.33	500 95.46	1000 89.88	1500 84.56	2000 79.50	2500 74.69	3000 70.12	3500 65.78	4000 61.66	4500 57.75	5000 54.05	5500 50.54
-40		0.79	0.84	0.89	0.95	1.01	1.08	1.15	1.22	1.30	1.39	1.49	1.59
-30		0.83	0.88	0.93	0.99	1.05	1.12	1.19	1.27	1.36	1.45	1.55	1.66
-20		0.86	0.91	0.97	1.03	1.10	1.17	1.24	1.33	1.41	1.51	1.61	1.73
-10		0.89	0.95	1.01	1.07	1.14	1.21	1.29	1.38	1.47	1.57	1.68	1.79
0		0.93	0.99	1.05	1.11	1.18	1.26	1.34	1.43	1.53	1.63	1.74	1.86
10		0.96	1.02	1.09	1.15	1.23	1.31	1.39	1.48	1.58	1.69	1.80	1.93
20		1.00	1.06	1.12	1.19	1.27	1.35	1.44	1.54	1.64	1.75	1.87	2.00
30		1.03	1.09	1.16	1.23	1.31	1.40	1.49	1.59	1.69	1.81	1.93	2.07
40		1.06	1.13	1.20	1.28	1.36	1.44	1.54	1.64	1.75	1.87	2.00	2.13
50		1.10	1.17	1.24	1.32	1.40	1.49	1.59	1.69	1.81	1.93	2.06	2.20
60		1.13	1.20	1.28	1.36	1.44	1.54	1.64	1.74	1.86	1.99	2.12	2.27
70		1.17	1.24	1.31	1.40	1.49	1.58	1.69	1.80	1.92	2.05	2.19	2.34
80		1.20	1.27	1.35	1.44	1.53	1.63	1.73	1.85	1.97	2.11	2.25	2.41
90		1.23	1.31	1.39	1.48	1.57	1.67	1.78	1.90	2.03	2.17	2.31	2.47
100		1.27	1.35	1.43	1.52	1.62	1.72	1.83	1.95	2.08	2.23	2.38	2.54
125		1.35	1.44	1.53	1.62	1.72	1.84	1.96	2.08	2.22	2.37	2.54	2.71
150		1.44	1.53	1.62	1.72	1.83	1.95	2.08	2.22	2.36	2.52	2.70	2.88
175		1.52	1.62	1.72	1.83	1.94	2.07	2.20	2.35	2.50	2.67	2.86	3.05
200		1.61	1.71	1.81	1.93	2.05	2.18	2.32	2.48	2.64	2.82	3.01	3.22
225		1.69	1.80	1.91	2.03	2.16	2.30	2.45	2.61	2.78	2.97	3.17	3.39
250		1.78	1.89	2.00	2.13	2.27	2.41	2.57	2.74	2.92	3.12	3.33	3.56
275		1.86	1.98	2.10	2.23	2.37	2.53	2.69	2.87	3.06	3.27	3.49	3.73
300		1.95	2.07	2.20	2.33	2.48	2.64	2.81	3.00	3.20	3.42	3.65	3.91
325		2.03	2.16	2.29	2.44	2.59	2.76	2.94	3.13	3.34	3.57	3.81	4.08
350		2.12	2.25	2.39	2.54	2.70	2.87	3.06	3.26	3.48	3.72	3.97	4.25
375		2.20	2.34	2.48	2.64	2.81	2.99	3.18	3.39	3.62	3.86	4.13	4.42
400		2.29	2.43	2.58	2.74	2.92	3.10	3.31	3.52	3.76	4.01	4.29	4.59

EXAMPLE:

Air at 1000m and 60°C: 89.88 kPa x 1.28 = 115.05 kPa

VELOCITY PRESSURE

Velocity pressure is total pressure minus static pressure. See Building Airflow System Control Applications section.

Table 22. Velocities for Different Velocity Pressures at Standard Air Conditions (20°C, 101.325 kPa).

VP	V	VP	V	VP	V	VP	V	VP	V	VP	V
2.50	2.038	127.50	14.555	252.50	20.483	377.50	25.044	502.50	28.895	650.00	32.863
5.00	2.882	130.00	14.697	255.00	20.584	380.00	25.127	505.00	28.967	675.00	33.489
7.50	3.530	132.50	14.838	257.50	20.684	382.50	25.210	507.50	29.038	700.00	34.104
10.00	4.076	135.00	14.977	260.00	20.785	385.00	25.292	510.00	29.110	725.00	34.707
12.50	4.557	137.50	15.115	262.50	20.884	387.50	25.374	512.50	29.181	750.00	35.301
15.00	4.992	140.00	15.252	265.00	20.983	390.00	25.456	515.00	29.252	775.00	35.884
17.50	5.392	142.50	15.387	267.50	21.082	392.50	25.537	517.50	29.323	800.00	36.458
20.00	5.765	145.00	15.522	270.00	21.180	395.00	25.618	520.00	29.394	825.00	37.024
22.50	6.114	147.50	15.655	272.50	21.278	397.50	25.699	522.50	29.464	850.00	37.580
25.00	6.445	150.00	15.787	275.00	21.376	400.00	25.780	525.00	29.535	875.00	38.129
27.50	6.760	152.50	15.918	277.50	21.473	402.50	25.860	527.50	29.605	900.00	38.670
30.00	7.060	155.00	16.048	280.00	21.569	405.00	25.941	530.00	29.675	925.00	39.203
32.50	7.348	157.50	16.177	282.50	21.665	407.50	26.021	532.50	29.745	950.00	39.730
35.00	7.626	160.00	16.305	285.00	21.761	410.00	26.100	535.00	29.815	975.00	40.249
37.50	7.893	162.50	16.432	287.50	21.856	412.50	26.180	537.50	29.884	1000.00	40.762
40.00	8.152	165.00	16.558	290.00	21.951	415.00	26.259	540.00	29.954	1025.00	41.268
42.50	8.403	167.50	16.682	292.50	22.045	417.50	26.338	542.50	30.023	1050.00	41.768
45.00	8.647	170.00	16.807	295.00	22.139	420.00	26.417	545.00	30.092	1075.00	42.263
47.50	8.884	172.50	16.930	297.50	22.233	422.50	26.495	547.50	30.161	1100.00	42.751
50.00	9.115	175.00	17.052	300.00	22.326	425.00	26.573	550.00	30.230	1125.00	43.234
52.50	9.340	177.50	17.173	302.50	22.419	427.50	26.651	552.50	30.298	1150.00	43.712
55.00	9.559	180.00	17.294	305.00	22.511	430.00	26.729	555.00	30.367	1175.00	44.185
57.50	9.774	182.50	17.413	307.50	22.603	432.50	26.807	557.50	30.435	1200.00	44.652
60.00	9.985	185.00	17.532	310.00	22.695	435.00	26.884	560.00	30.503	1225.00	45.115
62.50	10.190	187.50	17.650	312.50	22.787	437.50	26.961	562.50	30.571	1250.00	45.573
65.00	10.392	190.00	17.768	315.00	22.877	440.00	27.038	565.00	30.639	1275.00	46.027
67.50	10.590	192.50	17.884	317.50	22.968	442.50	27.115	567.50	30.707	1300.00	46.476
70.00	10.785	195.00	18.000	320.00	23.058	445.00	27.191	570.00	30.774	1325.00	46.920
72.50	10.975	197.50	18.115	322.50	23.148	447.50	27.268	572.50	30.842	1350.00	47.361
75.00	11.163	200.00	18.229	325.00	23.238	450.00	27.344	575.00	30.909	1375.00	47.797
77.50	11.348	202.50	18.343	327.50	23.327	452.50	27.420	577.50	30.976	1400.00	48.230
80.00	11.529	205.00	18.456	330.00	23.416	455.00	27.495	580.00	31.043	1425.00	48.659
82.50	11.708	207.50	18.568	332.50	23.504	457.50	27.571	582.50	31.110	1450.00	49.084
85.00	11.884	210.00	18.679	335.00	23.593	460.00	27.646	585.00	31.177	1475.00	49.505
87.50	12.057	212.50	18.790	337.50	23.680	462.50	27.721	587.50	31.243	1500.00	49.923
90.00	12.229	215.00	18.900	340.00	23.768	465.00	27.796	590.00	31.310	1525.00	50.337
92.50	12.397	217.50	19.010	342.50	23.855	467.50	27.870	592.50	31.376	1550.00	50.748
95.00	12.564	220.00	19.119	345.00	23.942	470.00	27.945	595.00	31.442	1575.00	51.156
97.50	12.728	222.50	19.227	347.50	24.029	472.50	28.019	597.50	31.508	1600.00	51.560
100.00	12.890	225.00	19.335	350.00	24.115	475.00	28.093	600.00	31.574	1625.00	51.961
102.50	13.050	227.50	19.442	352.50	24.201	477.50	28.167	602.50	31.640	1650.00	52.359
105.00	13.208	230.00	19.549	355.00	24.287	480.00	28.241	605.00	31.705	1675.00	52.755
107.50	13.365	232.50	19.655	357.50	24.372	482.50	28.314	607.50	31.771	1700.00	53.147
110.00	13.519	235.00	19.760	360.00	24.457	485.00	28.387	610.00	31.836	1725.00	53.536
112.50	13.672	237.50	19.865	362.50	24.542	487.50	28.460	612.50	31.901	1750.00	53.923
115.00	13.823	240.00	19.969	365.00	24.626	490.00	28.533	615.00	31.966	2000.00	57.646
117.50	13.972	242.50	20.073	367.50	24.711	492.50	28.606	617.50	32.031	2250.00	61.143
120.00	14.120	245.00	20.176	370.00	24.794	495.00	28.678	620.00	32.096	2500.00	64.450
122.50	14.267	247.50	20.279	372.50	24.878	497.50	28.751	622.50	32.160	2750.00	67.596
125.00	14.411	250.00	20.381	375.00	24.961	500.00	28.823	625.00	32.225	3000.00	70.601

VP = Velocity Pressure (pascals)

V = Velocity (meters per second)

MOISTURE CONTENT OF AIR DATA

See Psychrometric Chart Fundamentals section for use of the psychrometric chart.

MOISTURE IN COMPRESSED AIR

Compressed air cannot hold as much moisture as air at atmospheric pressure. When compressed, moisture often condenses out leaving the air saturated with moisture. Pneumatic systems require dry air to prevent problems with

actuators or filters or restrictions in controllers. Figure 7 is used to determine the maximum water vapor content of compressed air at various temperatures and pressures.

EXAMPLE:

Assume ambient conditions are 25°C and 80 percent rh.
 The air is compressed and stored in a tank at 310 kPa and 30°C.
 Air is delivered to the controls at 240 kPa.

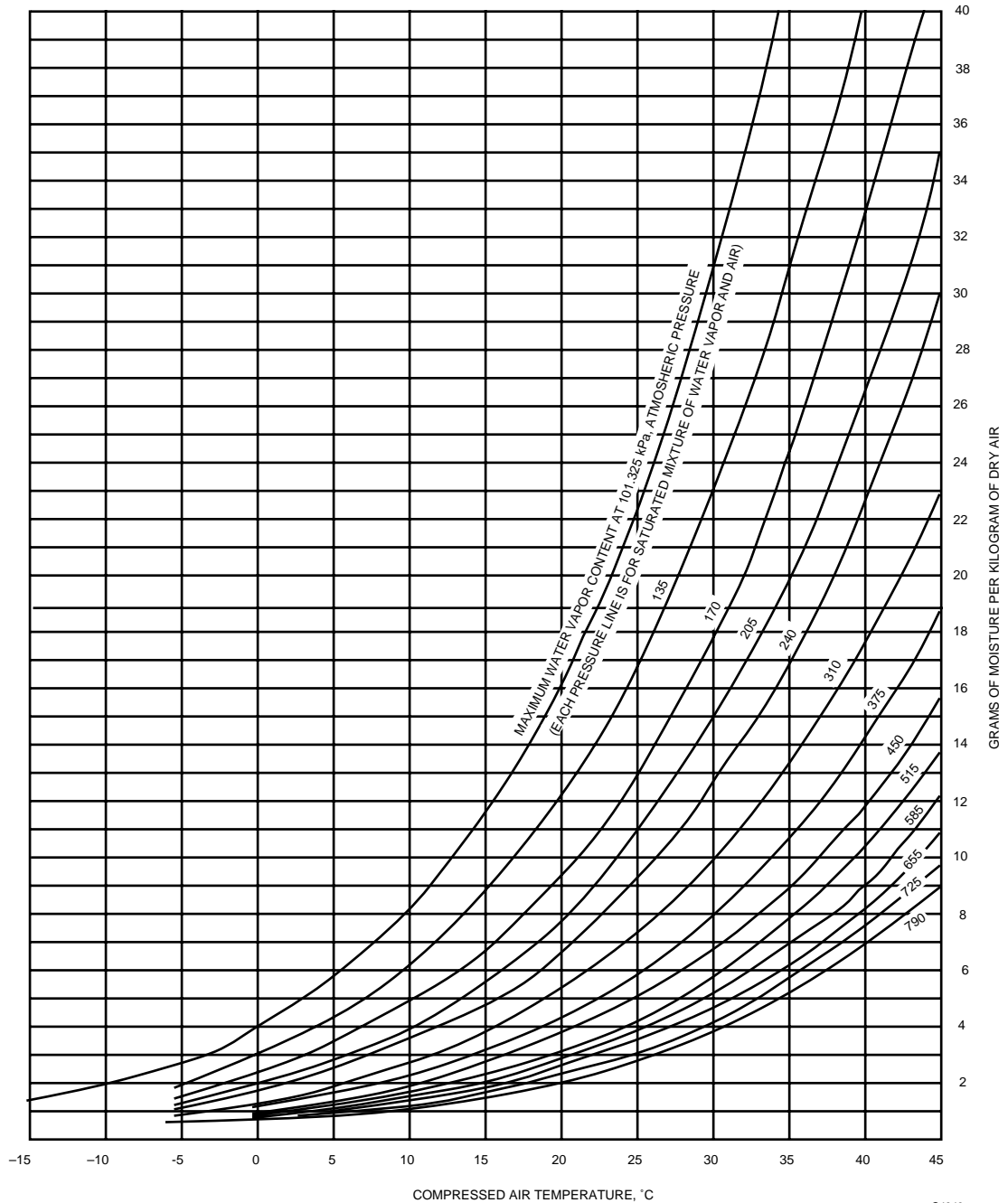

Fig. 7. Moisture in Compressed Air Versus Temperature and Pressure.

Use a psychrometric chart to determine that the ambient air at 25°C and 80 percent rh contains 16 grams of moisture per kilogram of dry air. See Psychrometric Chart Fundamentals section. On Figure 7 locate intersection of 30°C and 310 kPa lines. Follow to right of chart and determine that the compressed air is saturated at 10 grams of moisture per kilogram of dry air. The difference between 16 and 10 is 6 grams of moisture per kilogram of dry air which condenses and collects on the bottom of the air compressor storage tank.

When the air pressure is reduced to 240 kPa and distributed to the control system, the temperature will drop to approximately the 25°C ambient. The air can now contain only 9.2 grams of moisture per kilogram of dry air. This means that 0.8 grams of moisture per kilogram of dry air condenses and collects in low places in the tubing.

As the compressed air temperature is reduced further as it passes through air at a lower ambient temperature, additional moisture will condense. This may plug filters and restrictors in controllers or collect in valve or damper actuators.

The problem is controlled by use of an air dryer. The suggested alternative of a much higher pressure can have the same condensation problem.

EXAMPLE:

Using the design summer conditions for Phoenix, Arizona of 40°C dry bulb and 25°C wet bulb, the air contains 13.8 grams of moisture per kilogram of dry air. If the air is compressed to 725 kPa and the tank temperature is maintained at 45°C, then the air leaving the tank will contain 9.6 grams of moisture per kilogram of dry air. At 240 kPa the air is saturated at 26°C. If the compressed air temperature drops below 26°C, moisture will condense out of the air.

RELATIVE HUMIDITY

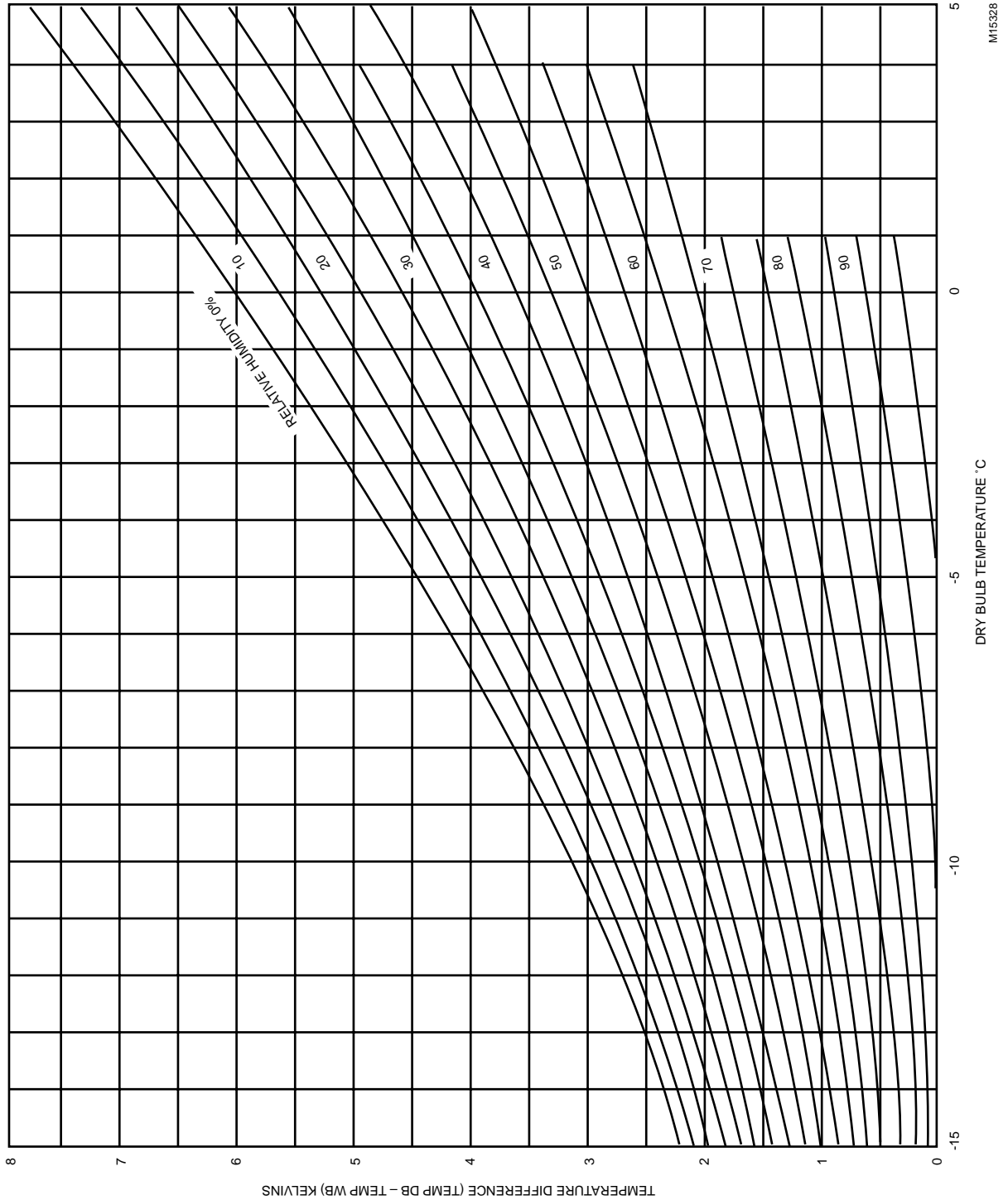

M15328

Fig. 8. Relative Humidity for Normal Dry Bulb and Wet Bulb Temperatures.

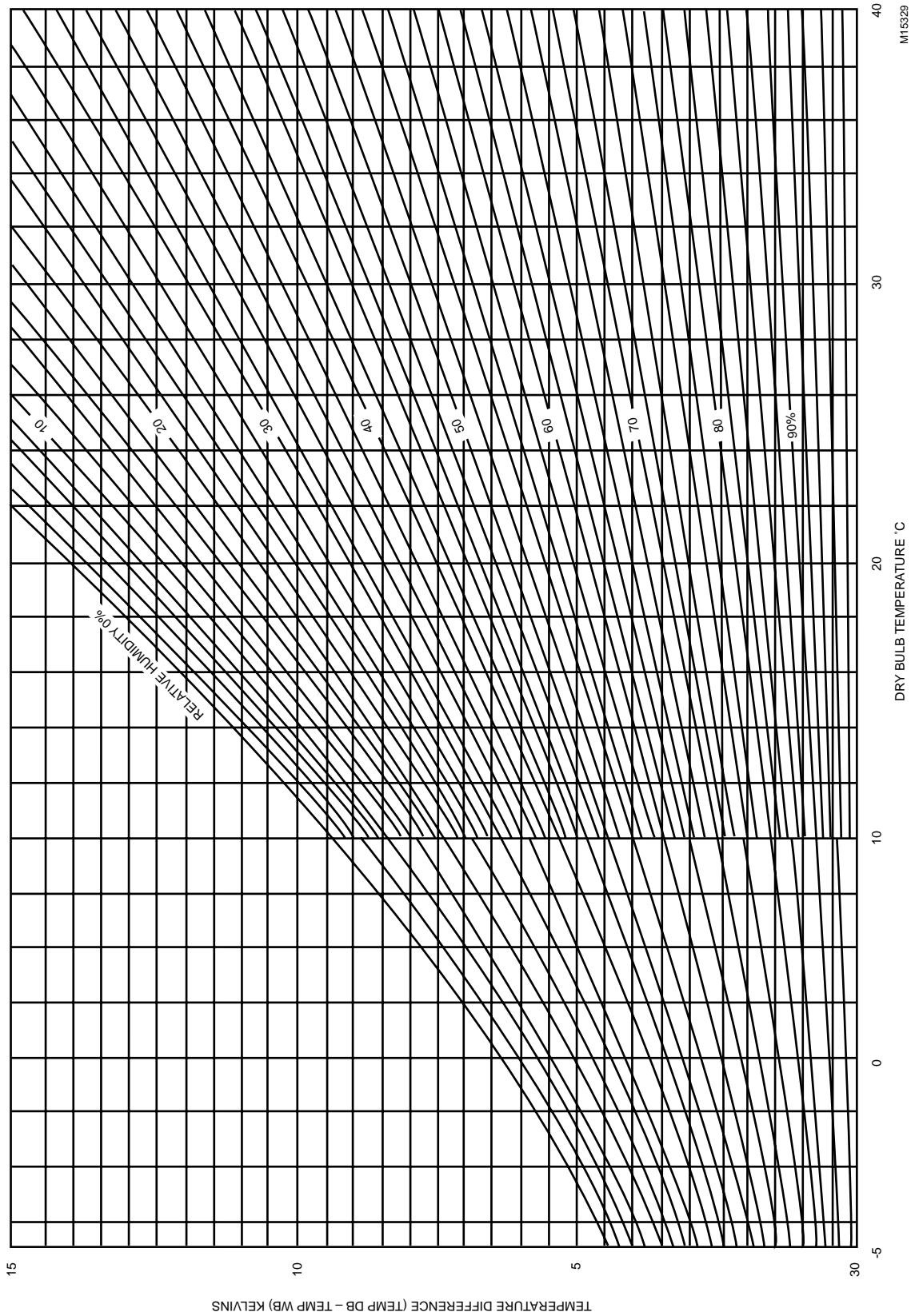

Fig. 9. Relative Humidity for Low Dry Bulb and Wet Bulb Temperatures.

INDEX

- A**
- Abbreviations
 - Chiller, Boiler, and Distribution System Control 295
 - Absorption Chiller 300
 - Absorption Chiller Control
 - With Centrifugal Chiller 313
 - Absorption Cycle 299
 - Absorption Refrigeration 299
 - Acceptance testing 163
 - Actuator 33, 74
 - Electric 97
 - Non-Spring Return 97
 - Series 40 100
 - Series 60 Floating 106
 - Series 60 Two-Position 103
 - Series 90 107
 - Spring-Return 97
 - Two-Position 97
 - Electronic 128
 - Modulating 128
 - Two-Position 128
 - Pneumatic 59
 - Valve 428
 - Adaptive control 26
 - Adiabatic Process 38
 - Aerosol 151
 - Air cleaner 151
 - Air Compressor 65
 - Air Conditioning Processes 43
 - Air contaminant
 - Building response 158
 - Eliminating level 158
 - Eliminating source 158
 - Human response 158
 - Remediating level 159
 - Source 154
 - Type 157
 - Air Drying Techniques 66
 - Condensing Drying 67
 - Desiccant Drying 67
 - Air Filter 68
 - Air Handling System Control Applications 201
 - Cooling control processes 236
 - Dehumidification control processes 243
 - Heating control processes 223
 - Heating system control processes 246
 - Humidification control processes 235
 - Preheat control processes 228
 - Requirements for effective control 204
 - Ventilation control processes 209
 - Year-round system control processes 248
 - Air Mixing Process 42
 - Air quality standard 151
 - Air Supply Equipment 65
 - Air Terminal Unit
 - Constant Air Volume 402
 - Control 399
 - Dual Duct
 - Pressure Independent 406, 407
 - Dual-Duct 406
 - Induction VAV 402
 - Parallel Fan 404
 - Pressure Independent
 - Constant Volume 407
 - Dual Duct 406
 - Pressure-Dependent 399
 - Series Fan 404
 - Single-Duct VAV 400
 - Throttling VAV 400
 - Variable Air Volume 399, 401, 402
 - Air volume types
 - Constant 267
 - Constant versus variable 268
 - Variable 267
 - Air Washer
 - Cooling and Dehumidification 51
 - Humidification 49
 - Airflow control
 - Applications
 - Central fan system control 280
 - Exhaust system control 287
 - Zone airflow control 285
 - Fundamentals
 - Airflow in ducts 274
 - Fans and fan laws 271
 - Measurement 277
 - Need for airflow control 266
 - Pressurization and ventilation 270
 - Types of airflow systems 267
 - What is airflow control 266
 - Airflow Data 477
 - Airflow in ducts
 - Effects of
 - Air terminal units 276
 - Dampers 276
 - Pressure changes 274
 - Airflow measuring devices 279
 - Airflow tracking/space static pressure 285
 - Alarm
 - Lockout 142
 - Monitoring 142
 - Algorithm 5, 16, 24, 26, 33
 - Analog 5
 - Analog and digital control 16
 - Analog-to-Digital (A/D) Converter 133
 - Application Software 133, 137
 - Approach 295
 - Area Conversion Multipliers 467
 - ASHRAE
 - Guideline 1-1989 164
 - Standard 62-1989 160

ASHRAE Psychrometric Charts 53, 261
 Authority 59
 Electronic 120
 Automatic control system 5, 16
 Auxiliary equipment 34
 Averaging Element 64
 Averaging Relay 80

B

BACNET 184, 189
 Bakeout 151
 Balancing Valve
 Considerations 357
 Effects 357
 Elimination 357
 BALCO Wire 123
 Ball Valve 430, 433
 BCS 184
 Bimetal 63
 BMCS 184
 BMCS Automation Operation 191
 BMCS/Chiller Interface 301
 BMS 184
 Boiler
 Combustion 329
 Control 327
 Controls 330
 Application 331
 Dual Control 333
 Output Control 330
 Ratings and Efficiency 328
 Types 327
 Boiler Systems
 Multiple 332
 Boilers
 Cast Iron 327
 Electric 328
 Modular 327
 Steel 327
 Booster Pump station 381
 Brake
 Solenoid 97, 100, 101
 Branch Line 59
 Bridge Circuit Theory 108
 British Thermal Unit 38
 Btu 38
 Building Airflow System Control Applications 263
 Building Automation and Control Network 184
 Building Control System 184
 Building Management and Control System 184
 Building Management System Fundamentals 183
 Building Management
 Software 142
 System 184
 Building pressure balance 270
 Butterfly Valve 431, 433

C

Capacity index 429
 Capacity Relay 79
 Celsius/Fahrenheit Conversion Tables 469
 Central Cooling Plants 302
 Central plant 295
 Centrifugal Chiller
 Control
 Application 303, 307
 Multiple Dissimilar 313
 Multiple Similar 309
 Single 302
 Centrifugal Chiller Control
 with Absorption Chiller 313
 Centrifugal Compressor 295, 298
 Changeover Control 87
 Characteristics
 Valve Flow 428
 Chilled Water Distribution Systems 364
 Chilled Water Systems 302
 Chiller
 Absorption 300
 Safety Controls 301
 Types 297
 Chiller, Boiler, and Distribution
 System Control Applications 291
 Chiller Control
 Requirements 301
 Chiller Heat Recovery System 323
 Chiller Pump Optimization 314
 Chiller System Control Applications 305
 Chiller/BMCS Interface 301
 Chillers 12
 Close-off 429
 Rating 429
 three-way valves 430
 Codes and standards 162
 Coefficient of Heat Transfer Conversion Multipliers 470
 Combined Heat & Power 381
 Combustion
 Control 330
 In Boilers 329
 Commissioning 151
 Communications Media 188
 Fiber Optic 188
 Phone Lines 188
 Twisted Copper Pair 188
 Communications Module 137
 Communications Protocol 184, 188
 Peer 188
 Compensation
 Authority 120
 Change-Over 120
 Control 5, 59, 120
 Sensor 120
 Components
 Valve 428

- Compressor 295
 - Centrifugal 298
 - Reciprocating 299
 - Screw 299
 - Computer Based Control 134
 - Condensate Return Systems 370
 - Condenser
 - Double bundle 295
 - Condenser Water Control 316
 - Condensing Drying 67
 - Configuration Programming 143
 - Constant Air Volume ATUs 402
 - Constant speed pumping 295
 - Contact Arrangement 98
 - Contact Rating 100
 - Contactors and Relays 114
 - Contacts 100, 102, 103, 114
 - Containment pressurization 270
 - Contaminant 151
 - Control
 - Chilled Water System 297
 - Electric
 - Damper 105
 - High-Limit 111
 - Low-Limit 111
 - Steam Valve 105
 - Summer/Winter Changeover 105
 - Unit Heater 101
 - Principles For Steam Heating Devices 371
 - Control Fundamentals 3
 - Control agent 5, 15, 26
 - Control application guidelines 29
 - Control Applications 164
 - District Heating 387
 - Control Circuits
 - Electric 97
 - Control loop 15
 - Control methods 16
 - Control Modes 17
 - Electronic 128
 - Control Point 5, 59, 120
 - Control Systems
 - Electronic 120
 - Controlled medium 5
 - Controlled Variable 5, 15, 59
 - Controller 5, 33, 98
 - Configuration 133
 - DDC
 - Configuration 135
 - Microprocessor-Based 135
 - Programming 142
 - System-Level 134, 146
 - Zone-level 133, 145
 - Electric
 - Classification 99
 - High-Limit 101, 103, 111
 - Low-Limit 102, 103, 111
 - Series 40 100
 - Series 60 Floating 106
 - Series 60, Two-Position 103
 - Series 80 102
 - Series 90 107
 - Spdt 106
 - Electronic 121, 127
 - Enthalpy 128
 - Relative Humidity 128
 - Temperature 128
 - Universal 128
 - Pneumatic 59
 - Humidity 71
 - Pressure 71
 - Temperature 71
 - Programming 142
 - System-Level 133, 185, 187
 - Zone-Level 133, 185, 186
- Convection 11
- Convection heater 10
- Conversion Formulas and Tables 466
 - Area 467
 - Density 472
 - Flow 470
 - Force 472
 - Heat Transfer 470
 - Length 467
 - Mass Per Unit Volume of Water 468
 - Power 471
 - Pressure 466
 - Specific Heat 468
 - Temperature 468
 - Torque 472
 - Velocity 470
 - Volume 468
 - Weight/Mass 467
 - Work/Energy 471
- Converter
 - Analog-to-Digital 133
 - Digital-to-Analog 133
 - Instantaneous Control 376
- Converters
 - Hot Water 358
- Convertor 382
- Cooling 11
- Cooling and Dehumidification 51
- Cooling Anticipation 102
- Cooling control processes 236
- Cooling Process 44
- Cooling Tower
 - Capacity Control 316
 - Control 316

- Fan Control
 - On-Off 317
 - Two-Speed 317
 - Variable Speed 318
 - Free Cooling 323
 - Dual Chillers 325
 - Performance Characteristics 316
 - Corrective action 5
 - Critical pressure drop 430
 - Custom Control Programming 143
 - Cycle 5
 - Cycling 5
 - Cycling rate 5
- D**
- Damper
 - Actuator and Linkage
 - Actuator selection 457
 - Jackshaft 457
 - Multiple actuators 456
 - Positive positioner 456
 - Application Environment
 - Corrosion 455
 - Nuclear/Seismic 455
 - Static Pressure 455
 - Temperature 455
 - Turbulence 455
 - Velocity 454
 - Applications
 - Face and bypass Control 464
 - Mixed Air Control 463
 - Throttling Control 464
 - Baffle 451
 - Construction 452
 - Mounting alternatives 456
 - Normally open/normally closed 455
 - Performance data
 - Leakage rating 452
 - Pressure rating 454
 - Temperature rating 454
 - Torque requirement 454
 - UL Classification (fire/Smoke) 454
 - Velocity rating 454
 - Pressure drop 462
 - Sizing
 - Damper Characteristics 458, 461
 - Determining Size 459
 - Other considerations 461
 - System Characteristics 457
 - Types
 - Fire 450
 - Low Leakage 448
 - Multiple section 451
 - Parallel and opposed Blade 448
 - Round 448
 - Smoke 450
 - Damper Control 105
 - Damper Selection and Sizing 445
 - Dampers 76
 - Data File Programming 143
 - Data Penetration 195
 - DDC 6
 - Deadband 6, 295
 - Definitions
 - Chiller, Boiler, And Distribution System Control 295
 - Dehumidification 12
 - Dehumidification and Reheat 52
 - Dehumidification control processes 243
 - Dehumidifier
 - Air Washer 51
 - Density 38
 - Density Conversion Multipliers 472
 - Desiccant Drying 67
 - Design considerations 158
 - Design procedures
 - Indoor air quality 161
 - Ventilation rate 161
 - Deviation 6, 120
 - Dew Point Temperature 38
 - Differential 59
 - Differential Pressure Sensor Location 357
 - Digital 6
 - Digital control 6
 - Digital Unit Ventilator Control 415
 - Digital-to-Analog (D/A) Converter 133
 - Direct Acting 59, 120
 - Direct Digital Control 133, 134
 - Direct Digital Control Software 137
 - Direct Heat Transfer Substations 384
 - Discharge Air 59
 - Distributed Power Demand 137
 - Distribution System
 - AHU Valve High Differential Pressure Control 352
 - Flow and Pressure Control Solutions 348
 - Fundamentals 345
 - Steam
 - Supply and Return Main Pressures 373
 - Valve Selection 348
 - Water 335
 - Distribution Systems
 - Chilled Water 364
 - Classification of Water 335
 - Control 335
 - Hot Water 358
 - Low Pressure Steam 370
 - Methods of Controlling 348
 - Steam 368
 - Condensate Return 370
 - Control 366
 - Variable Vacuum Return 371
 - Water
 - Control Requirements 336

District Heating 380
 Booster Pump Station 383
 Definitions 381
 Distribution Network 380
 Heat Distribution Network 382
 Heat generation 382
 Heat Sources 380
 Hot Water Pipeline 383
 Hot Water System Control 382
 Mixing Station 383
 Primary Network 381
 Secondary Network 381
 Substation 381
 System Configuration 382
Diversity 295
Diverting Valve 436
Domestic Hot Water 381
Double bundle 295
Double-seated valve 431
Down-Blow Unit Heater 410
Droop 6, 19
Dry Air Requirement 66
Dry-Bulb Temperature 38
Dual Duct
 ATU 406
 Constant Volume ATU 407
Dual Temperature Systems 365
 Changeover Precautions 365
 Multiple-Zone 365
Dynamic Display Data 184

E

Economizer 215, 217, 218, 219, 220, 222, 248, 255
Effects of
 Humidity 160
 Temperature 159
Electric Control 6, 120
Electric Control Circuits 97, 99
Electric Control Combinations
 Series 40 101
 Series 60 Floating 106
 Series 60 Two-Position 105
 Series 80 103
 Series 90 111
Electric Control Fundamentals 95
Electric Motors 475
Electric-Pneumatic Relay 82, 87
Electrical Conductors 475
Electrical Data 473
Electrical Distribution Systems 473
 Single-Phase System 473
 Three-Phase Delta System 474
 Three-Phase Four-Wire Wye System 474
 Three-Phase Three-Wire Wye System 474

Electronic
 Indicating Devices 129
 Output Control 128
 Output Devices 128
 Power Supply 129
 System Application 130
 Transducer 129
Electronic Control 6, 120
Electronic Control Fundamentals 119
Electronic Control Systems 120
Electronic Controller 121, 129
Electronic-Pneumatic Transducer 83
Electrostatic air cleaner 152
Emission standard 152
EMS 184
Energy Management 184
Energy Management Software 138
 Distributed Power Demand 142
 Enthalpy 139
 Load Reset 139
 Night Cycle 138
 Night Purge 139
 Optimum Start 138
 Optimum Stop 138
 Zero Energy Band 141
Energy Management System 184
Energy/Work Conversion Multipliers 471
Enhanced proportional-integral-derivative (EPID) 6, 25
Enthalpy 39, 139
Enthalpy Controllers
 Electronic 128
EPID control 6, 26
Equal Percentage Valve 435
Ethylene Glycol Solutions 437
Expansion valve 297

F

Facilities Management 185
Fahrenheit/Celsius Conversion Tables 469
Fan
 Duct system curve 273
 Fan and duct system curve comparison 273
 Horsepower 273
 Laws 273
 Performance terms 272
 Types 272
Fan Coil Units 418
 Four-Pipe Heating/Cooling
 Single Coil 420
 Split Coil 420
 Two-Pipe Heating/Cooling 419
Fan Interlock 117
Fan Ratings 477
Feed and Bleed System 63
Fiber Optic 188
Filtration 14
Final Control Element 6, 59

- Flame Safeguard
 - Control 330
 - Instrumentation 331
- Floating Control 20
 - Electric 107
- Flow
 - (Gas/Air) Conversion Multipliers 470
 - (Liquid) Conversion Multipliers 470
- Sensing element 32
- Flow coefficient 429
- Flow tracking 165, 166, 258, 285
- Flue Gas Analysis 329
- Flushout 152
- Force Conversion Multipliers 472
- Free Cooling-Tower Cooling 323
- Fume hood control 287
- Functions
 - Operations-Level 189
 - Alarm Processing 190
 - Communications Software 189
 - Controller Support 191
 - Hardware 189
 - Reports 190
 - Security 190
 - Server 190
 - Software 189
 - Standard Software 189
 - System Graphics 190
 - System Text 190
 - System-Level Controller 189
 - Zone-Level Controller 189
- Fundamentals
 - Control 5
 - Electronic Controller 129
 - Indoor Air Quality 152
- G**
 - Gas Burners 329
 - Gas- or Oil-Fired Unit Heater 411
 - General Engineering Data 465
 - Global Points 142
 - Globe Valve 431, 433
 - Glycol Solutions 437, 438
 - Graphic
 - Control 195
 - Specifying 193
 - Graphic display 168
 - Graphic Penetration 195
- H**
 - Hand-Off-Auto Start-Stop Circuit 115
 - Hardware Configuration 186
 - Heat anticipation 18
 - Heat Exchanger 381
 - Heat Exchanger Substation 381
 - Heat pump 11, 421
 - Operation 421
 - Heat Recovery System 323
 - Heat Surface Factor 381
 - Heat Transfer Station 381
 - Heating 9
 - Heating Anticipation 102
 - Heating coil 10
 - Heating control processes 223
 - Heating Process 43
 - Heating system control processes 246
 - HEPA filter 152
 - Hesitation Relay 82
 - Hierarchical Configuration 184
 - High Temperature Water
 - Control Selection 375
 - Heating System Control 374
 - Safety 375
 - Space Heating Units 378
 - Steam Generators 379
 - Valve Flow Characteristics 376
 - Valve Selection 375
 - High Temperature Water (HTW)
 - Heating 374
 - High-Limit Controller 101, 103, 111
 - High-Pressure Selector Relay 79
 - Hot and Chilled Water Distribution Systems Control 335
 - Hot Water
 - Control Method Selection 364
 - Reset 361
 - Supply Temperature Control 361
 - Flow Control 361
 - Hot Water Systems
 - Control 360
 - Modulating 360
 - HTW
 - Coils 377
 - Control Selection 375
 - Space Heating Units 378
 - HTW Steam Generators 379
 - HTW Valve Selection 375
 - HTW Water Converters
 - Multizone Space-Heating 378
 - Humidification 13
 - Humidification control processes 235
 - Humidifier
 - Air Washer 49
 - Steam Jet 46
 - Vaporizing 50
 - Humidifying Process 44
 - Humidity. *See* Relative Humidity
 - Humidity Controller 71
 - Humidity Ratio 38
 - Hunting 6
 - Hybrid Heat Transfer Substations 386
 - Hydronic Systems
 - Corrosive Elements 432
 - Hysteresis 140

I

I/O Summary 193
In-Depth Integration 196
Indicating Device
 Electronic 129
Indirect Heat Transfer Substations 385
Individual Room Control Applications 395
Individual Room Control Automation 423
Indoor air quality
 Acceptance testing 163
 Air contaminants 154
 Codes and standards 162
 Concerns 154
 Control applications 164
 Design considerations 158
 Design procedures 160
 Indoor air contaminant indicators 158
Indoor Air Quality Fundamentals 149
Induction VAV ATU 402
Infiltration 10
Infrared heater 10
Instantaneous Converter Control 376
Integral Action 121
Integration
 System 187
 In-Depth 188
 Surface 188
Isothermal Process 38

L

Laboratory pressurization control 288
Lag 27
Latent Heat 38
Legionnaires disease 152
Length Conversion Multipliers 467
Limit Control 85
Limit Controller 112
Limit Sensor 121
Line Voltage 99
Linear Valve 434
Load 6, 26
Load Analyzer Relay 79
Load Reset 135
Lockout Relay 78
Low Pressure Steam Distribution Systems 370
Low Voltage 99
Low-Limit Controller 102, 103, 111
Low-Pressure Selector Relay 79

M

Main Line 60
Main Sensor 121
Management-Level Processor 184, 187
Manipulated variable 6, 15, 60
Manual Minimum Positioning of Outdoor Air Damper 113
Manual Positioning Switch 84

Manual Switch Control 86
Materials safety data sheets 152
Measured variable 6
Metric Prefixes 466
Microprocessor-based control 6
Microprocessor-Based Controller 133, 135
Microprocessor-Based/DDC Fundamentals 131
Microprocessor-Based Systems 120
Mixed Air 60
Mixing Valve 436
Modulating 6, 60
Modulating Control
 Electric 107
Modulating Steam Coil Performance 371
Sensing element 32
Moisture Content 38
Moisture Content of Air Data 479
Moisture in Compressed Air 479
Momentary Fast-Slow-Off Start-Stop Circuit 116
Momentary Start-Stop Circuit 115
Motor
 Contactors and Relays 114
 Control Circuits 114
 Control Combinations 117
 Starters 114
 Hand-Off-Auto 115
 Momentary Fast-Slow-Off 116
 Momentary Push-Button 115
Motor Starter 128
Multiple Decoupled Chiller Control 313
Multizone Space-Heating HTW Water Converters 378

N

Natural Convection Units 408
Negative (Reverse) Reset 121
Night Cycle 138
Night purge control 285
Nozzle-Flapper Assembly 62

O

Off gassing 152
Offset 6, 21, 22, 60, 121
Oil Burners 329
On/off control 6
One-Pipe Steam Systems 370
Open-Closed Control 105
Operating Software 133, 137
Operation
 Series 40 101
 Series 60 Floating 106
 Series 60 Two-Position 104
 Series 80 102
 Series 90 108
Operations-Level
 Functions 189
 Processor 184, 187

- Operator interface 167
- Optimum Start 138
- Optimum Stop 138
- Output Control 128
- Output Devices 128

- P**
- Parallel Fan ATU 404
- Peer Communications Protocol 188
- Phone Lines 188
- PI 7
- PI control 23
- PID 7
- PID control 25
- Pilot Bleed System 62
- Pilot-operated valve 431
- Piping Arrangements
 - Hot Water 359
- Piping Systems
 - Coupled Vs Decoupled 347
 - Direct Vs Reverse Return 346
- Pitot tube sensors 277
- Pneumatic
 - Centralization 89
 - Control Combinations
 - Changeover Control 87
 - Electric-Pneumatic Relay Control 87
 - Limit Control 85
 - Manual Switch Control 86
 - Pneumatic Recycling Control 88
 - Pneumatic-Electric Relay Control 88
 - Reset Control 87
 - Sequence Control 85
 - Control System 61, 90
 - Controller 72
 - Potentiometer 81
 - Recycling Control 88
 - Sensor 73
 - Switch 83
- Pneumatic control 6
- Pneumatic Control Fundamentals 37
- Pneumatic-Electric Relay 82, 88
- Positive (Direct) Reset 121
- Positive displacement compressor 295
- Positive-Positioning Relay 80
- Power Supply
 - Electronic 129
- Preheat control processes 228
- Pressure Controller 71
- Pressure Conversion Multipliers 466
- Pressure drop 430
 - critical 430
- Pressure Independent
 - Constant Volume ATU
 - Dual Duct 407
 - VAV ATU
 - Dual Duct 406
- Pressure Reducing Stations
 - District Heating 383
- Pressure Reducing Valve Station 68, 369
- Pressure Reducing Valves 69
- Pressure Sensor
 - Electronic 127
- Pressure sensors 277
- Pressure-Dependent ATU 399
- Pressure-Independent ATU 399
- Primary Network 381
- Process 6
- Processor
 - Management-Level 184
 - Operations-Level 184
- Programming
 - Configuration 138
 - Custom Control 138
 - Data File 138
 - System Initialization 138
- Sensing element 33
- Properties of Saturated Steam Data 476
- Proportional Band 6, 22, 60, 121
- Proportional Control 6, 21, 121
- Proportional-Integral 121
- Proportional-integral (PI) control 7, 23
- Proportional-Integral Controller 72
- Proportional-integral-derivative (PID) control 7, 25
- Propylene Glycol Solutions 438
- Psi to kPa Conversion 466
- Psychrometric Aspects
 - Air Conditioning Process 43
 - Air Washer 49
 - Cooling and Dehumidification 51
 - Air Washer 51
 - Cooling Process 44
 - Dehumidification and Reheat 52
 - Heating Process 43
 - Humidifying Process 44
 - Mixed Air 42
 - Steam Jet Humidifier 46
 - Vaporizing Humidifier 50
- Psychrometric Chart Fundamentals 37
- Psychrometric Charts 39
 - ASHRAE 53
- Psychrometric Processes 40
- Pulse Width Modulation 128
- Pump
 - Affinity Laws 339
 - Efficiency 338
 - Performance 337
 - Performance Curves 338
 - Power Requirements 338
- Pump Control
 - Variable Speed 353
 - Decoupled 358
 - Minimum Flow 357
- Pump Speed Valve Position Load Reset 355

Pumping

- Constant speed 295
- Primary-Secondary 360
- Variable speed 296

Pumps

- Applied to Open Systems 343
- Centrifugal
 - Hot and Chilled Water Systems 336
- Matching to Water Distribution Systems 340
- Multiple 343
- Variable Speed 342

Q

- Quick-Opening Valve 434

R

- Radiant Panels 409
- Rangeability 296, 429
- Ratings
 - Valve 429
- Ratio Relay 81
- Reciprocating Compressor 295, 299
- Reduced-Port valve 431
- Refrigerant pressure 296
- Refrigeration
 - Absorption 299
 - Vapor-Compression 297
- Relative Humidity 38, 481
- Relative Humidity Controllers 128
- Relative Humidity Sensor
 - Electronic 125
- Relay 99
 - Electronic 128
 - Pneumatic
 - Averaging 80
 - Capacity 79
 - Electric-Pneumatic 82
 - Electronic-Pneumatic Transducer 83
 - Hesitation 82
 - High Pressure Selector 79
 - Load Analyzer 79
 - Lockout 78
 - Low-Pressure Selector 79
 - Pneumatic-Electric 82
 - Positive-Positioning 80
 - Ratio 81
 - Reversing 80
 - Snap Acting 78
 - Switching 77
 - Series 40 100
- Relays and Switches 64, 77
- Remote Setpoint 121
- Requirements for effective control 204

Reset

- from Outdoor air temperature 225
- Hot deck temperature 226
- Hot Water 361
- Negative 121
- Positive 121
- Supply Air Temperature 221, 224, 225
- Reset Authority 23, 120
- Reset Changeover 59
- Reset Control 7, 22, 60, 87, 121
- Resistance Temperature Devices 122, 124
- Restrictor 60, 62
- Return Air 60
- Reverse Acting 60
- Reversing Relay 80
- Rod and Tube 64
- Rooftop unit 167
- Run Time 142

S

- Saturation 38
- Screw Compressor 295, 299
- Secondary Network 381
- Selection and sizing
 - Damper 447
- Sensible Heat 38
- Sensing Element 7, 30, 31, 33
 - Averaging 64
 - Bimetal 63
 - Flow 32
 - Moisture 32
 - Pressure 31
 - Proof-of-operation 33
 - Rod and Tube 64
 - Temperature 30
- Sensor 60
 - Electronic Pressure 127
 - Electronic Relative Humidity
 - Capacitance 125
 - Quartz Crystal 126
 - Resistance 125
 - Electronic Temperature 122
 - BALCO 123
 - Platinum 124
 - Thermistor 124
 - Thermocouple 125
- Sensor Span 60
- Sensor-Controller
 - Pneumatic 72
 - Velocity 73
- Sequence Control 85
- Sequencing fan control 285
- Series 40
 - Controller 100
 - Operation 101

- Series 60
 - Actuators 103, 106
 - Controller 103
 - Floating Control Circuits 106
 - Floating Operation 106
 - Two-Position Control Circuits 103
 - Two-Position Operation 104
- Series 80
 - Control Circuits 102
 - Controller 102
 - Operation 102
- Series 90
 - Actuator 107
 - Bridge Circuit 108
 - Control Circuits 107
 - Controllers 107
 - Minimum Positioning 113
 - Operation 108
 - Switching Circuits 112
 - Transfer Circuits 112
- Series Fan ATU 404
- Setpoint 7, 15, 60, 121
- Short cycling 7
- Shut-off 429
- Sick building syndrome 153
- Signal Amplifier 63
- Single-Duct VAV ATU 400
- Single-Pressure Reducing Valve 69
- Single-seated valve 431
- Sizing 437, 441
- Sling Psychrometer 38
- Smoke control 285
- Smoke Management Fundamentals 171
 - Acceptance testing 181
 - Causes of smoke movement
 - Buoyancy 174
 - Expansion 175
 - HVAC 177
 - Stack effect 175
 - Wind velocity 176
 - Control of malls, atria, and large areas 181
 - Control of smoke
 - Airflow 178
 - Pressurization 177
 - Objectives 173
 - Codes and standards 174
 - General 173
 - Layout of system 174
 - Purging 178
 - Stairwell pressurization control 180
 - Zone pressurization control 179
- Snap Acting Relay 78
- Software
 - Application 133, 137
 - Building Management 142
 - Direct Digital Control 137
 - Operating 133, 134
- Solenoid Brake 97, 100, 101
- Solenoid Valve 128
- Specific Volume 39
- Spring Range 74
- Stack effect 271
- Starters 114
- Steam
 - Heating Devices 371
 - Pressure, Temperature, and Density 367
 - Properties 366
 - Quality 367
 - System
 - Objectives 366
- Steam Coil
 - Low Temperature Protection 373
 - Performance
 - Modulating 371
 - System Design Considerations 373
- Steam Distribution Systems 368
- Steam Distribution Systems and Control 366
- Steam Jet Humidifier 46
- Steam Piping Mains 368
- Steam System Heat Characteristics 367
- Steam Systems
 - Advantages 366
- Steam Traps 368
- Steam Valve
 - Control 105
 - Sizing 441
- Step control 7
- Step controller 19
 - Electric 114
- Storage Converters 378
- Strain Gage 127
- Substations
 - Direct Heat Transfer 384
 - Hybrid Heat Transfer 386
 - Indirect Heat Transfer 385
- Summer/Winter Changeover Control 105
- Superheat 296, 297
- Supply Air
 - Air Leaving an Air Handling System 60
- Supply and Return Main Pressures 373
- Surface Integration 196
- Surge 296
- Switch
 - Pneumatic
 - Pneumatic Manual Positioning 84
 - Pneumatic Potentiometer 81
 - Pneumatic Switch 83
- Switching Relay 77
- Symbols 296
- System Application
 - Electronic 130
- System Configurations 186
- System Initialization Programming 143
- System Integration 196
- System-Level
 - Controller 133, 136, 146, 185
 - Controller Functions 185

- T**
- Temperature
 - Dew-Point 38
 - Dry-Bulb 38
 - Wet-Bulb 39
 - Temperature Controller 71
 - Temperature Controllers
 - Electronic 128
 - Temperature Sensor
 - Electronic 122
 - Terminal Units
 - Control 365
 - Thermal Storage
 - Control 315
 - Control Modes 315
 - Thermistor 124
 - Thermocouple 125
 - Thermostat
 - Pneumatic 60
 - Dual Temperature 69
 - Dual-Acting 69
 - High Capacity, Single Temperature 69
 - Low-Capacity, Single Temperature 69
 - Three-way Valve 431, 436
 - Throttling Range 7, 22, 60, 121
 - Adjustment 64
 - Throttling VAV ATU 400
 - Time and Event Programs 142
 - Time constant 7
 - Time Proportioning 19, 102
 - Timed two-position control 18
 - Torque Conversion Multipliers 472
 - Total and static pressure sensors 278
 - Total Heat 39
 - Tower Free Cooling, Dual Chillers 325
 - Toxicity 153
 - Transducer 33
 - Electronic 121, 125, 128, 129
 - Electronic-to-Pneumatic 129
 - Transformer 99
 - Transmission 9
 - Transmitter
 - Electronic 121, 125, 127
 - Turndown 429
 - Twisted Copper Pair 188
 - Two-Pipe Steam Systems 370
 - Two-Position Control 7, 17, 105
 - Electric 107
 - Two-Pressure Reducing Valve 69
 - Two-Way Valve 431, 434
- U**
- Unbalanced loading 295
 - Unit Heater 10, 409
 - Control 101, 410
 - Modulating 410
 - Two-Position 410
 - Down-Blow 410
 - Gas Fired 411
 - Oil Fired 411
 - Unit Ventilator 10, 411
 - ASHRAE Control Cycles 412
 - Control 412
 - Day/Night Setback 414
 - Digital 415
 - Draw-through 412
 - Unitary Equipment Control 408
 - Universal Controllers
 - Electronic 128
- V**
- Valve 75
 - Ball 430, 433
 - Body rating 430
 - Butterfly 431, 433
 - Components 428
 - Diverting 436
 - Double-seated 431
 - Equal Percentage 435
 - Expansion 297
 - Globe 431, 433
 - Linear 434
 - Material and Media 431
 - Maximum
 - Pressure 430
 - Temperature 430
 - Mixing 436
 - Pilot-operated 431
 - Quick-Opening 434
 - Ratings 429
 - Reduced-Port 431
 - Selection 432
 - Single-seated 431
 - Sizing 437, 441
 - Steam
 - Sizing 441
 - Three-way 431
 - Two-way 431, 434
 - Types 430
 - Water
 - Sizing 437
 - Valve Control
 - Coil 348

Valve Flow
 Characteristics 376, 428
 Terms 429
Valve Selection and Sizing 427
Vapor-Compression
 Cycle 297
 Refrigeration 297
Vaporizing Humidifier 50
Variable Air Volume 267, 280
 Relief fan control 283
 Return air damper control 283
 Return fan control 281
 Supply fan control 280
Variable Air Volume ATU 399, 401, 402
Variable speed pumping (VSP) 296
Variable Vacuum Return Systems 371
Velocity Conversion Multipliers 470
Velocity Pressure 478
Velocity Sensor-Controller 73
Ventilation 10, 13
Ventilation control processes 209
Volatile organic compound 153
Voltage Conversion 475
Volume Conversion Multipliers 468

W

Warmup control 285
Water Valves
 Sizing 437
Weight/Mass Conversion Multipliers 467
Wet-Bulb Temperature 39
Wind pressure effect 271
Work/Energy Conversion Multipliers 471

Y

Year-round system control processes 248

Z

Zero Energy Band 7, 141
Zone-Level Controller 133, 145, 185, 186
 Functions 189
Zoning 7

NOTES

NOTES

NOTES

NOTES

NOTES

NOTES

NOTES