

## Lecture Notes: Clinical Anaesthesia

To Karen, Matthew and Mark. Thank you for the never-ending help, encouragement, humour and always having so much patience.

Lecture Notes  
**Clinical  
Anaesthesia**

**Carl L. Gwinnutt**

MB BS MRCS LRCP FRCA  
Consultant Anaesthetist  
Hope Hospital, Salford

Honorary Clinical Lecturer in Anaesthesia  
University of Manchester

Second Edition

 **Blackwell  
Publishing**

© 2004 C. Gwinnutt  
© 1997 Blackwell Science Ltd  
Published by Blackwell Publishing Ltd

Blackwell Publishing, Inc., 350 Main Street, Malden, Massachusetts 02148-5020, USA  
Blackwell Publishing Ltd, 9600 Garsington Road, Oxford OX4 2DQ, UK  
Blackwell Publishing Asia Pty Ltd, 550 Swanston Street, Carlton, Victoria 3053, Australia

The right of the Author to be identified as the Author of this Work has been asserted in accordance with the Copyright, Designs and Patents Act 1988.

All rights reserved. No part of this publication may be reproduced, stored in a retrieval system, or transmitted, in any form or by any means, electronic, mechanical, photocopying, recording or otherwise, except as permitted by the UK Copyright, Designs and Patents Act 1988, without the prior permission of the publisher.

First published 1997  
Reprinted 1998, 1999, 2000, 2001, 2002  
Second edition 2004

Library of Congress Cataloging-in-Publication Data  
Gwinnutt, Carl L.

Lecture notes on clinical anaesthesia / Carl L. Gwinnutt.—2nd ed.

p. ; cm.

Includes bibliographical references and index.

ISBN 1-4051-1552-1

1. Anesthesiology. 2. Anesthesia.

[DNLM: 1. Anesthesia. 2. Anesthetics—administration & dosage. WO 200 G9945L 2004] I. Title.

RD81.G843 2004

617.9'6—dc22

2004007261

ISBN 1-4051-1552-1

A catalogue record for this title is available from the British Library

Set in 8/12 Stone Serif by SNP Best-set Typesetter Ltd., Hong Kong  
Printed and bound in the United Kingdom by TJ International Ltd, Padstow, Cornwall

Commissioning Editor: Vicki Noyes  
Editorial Assistant: Nic Ulyatt  
Production Editor: Karen Moore  
Production Controller: Kate Charman

For further information on Blackwell Publishing, visit our website:  
<http://www.blackwellpublishing.com>

The publisher's policy is to use permanent paper from mills that operate a sustainable forestry policy, and which has been manufactured from pulp processed using acid-free and elementary chlorine-free practices. Furthermore, the publisher ensures that the text paper and cover board used have met acceptable environmental accreditation standards.

# Contents

Contributors	vi
Preface	vii
List of Abbreviations	viii
1 Anaesthetic assessment and preparation for surgery	1
2 Anaesthesia	15
3 Postanaesthesia care	71
4 Management of perioperative emergencies and cardiac arrest	90
5 Recognition and management of the critically ill patient	112
6 Anaesthetists and chronic pain	139
Index	151

# Contributors

**Tim Johnson**

*Consultant in Pain Management and Anaesthesia*  
Hope Hospital  
Salford

**Richard Morgan**

*Consultant Anaesthetist*  
Hope Hospital  
Salford

**Anthony McCluskey**

*Consultant in Anaesthesia and Intensive Care  
Medicine*  
Stepping Hill Hospital  
Stockport

**Jas Soar**

*Consultant in Anaesthesia and Intensive Care  
Medicine*  
Southmead Hospital  
Bristol

# Preface

In the first edition, I asked the question, 'Should medical students be taught anaesthesia?' I firmly believed that they should, and in the intervening years nothing has happened to change my view. Indeed, with the continuing expansion of the roles and responsibilities of anaesthetists, it is now more important than ever that as medical students you understand that we do far more than provide the conditions under which surgery can be performed safely. I hope that this second edition reflects these changes.

Anaesthetists are increasingly responsible for the development and care of patients preoperatively and postoperatively and in the recognition and management of those who are critically ill. With the help of my colleagues, I have tried to reflect this expanding role in the updated text, particularly as these are areas that as newly qualified doctors, you

will encounter before deciding on a career in anaesthesia. On the other hand, it is also important that you are aware of the continuing essential role that many of my colleagues play in treating and helping patients live with chronic pain problems and the principles upon which these are based.

With this edition, I have endeavoured to identify the skills you will need and the challenges you will meet in the early years after qualification. The book remains a skeleton on which to build, not only from within other texts, but also with clinical experience. I remain hopeful that if, after reading this book, you feel motivated to learn by desire rather than need I will be a little bit closer to achieving my aims.

Carl Gwinnutt

# List of Abbreviations

<b>AAGBI</b> Association of Anaesthetists of Great Britain & Ireland	<b>GI</b> gastrointestinal
<b>ADH</b> antidiuretic hormone	<b>GTN</b> glyceryl trinitrate
<b>AED</b> automated external defibrillator	<b>HAFOE</b> high airflow oxygen enrichment
<b>ALS</b> advanced life support	<b>HDU</b> high dependency unit
<b>ALT</b> alanine aminotransferase	<b>HIV</b> human immunodeficiency virus
<b>APC</b> activated protein C	<b>HR</b> heart rate
<b>APPT</b> activated partial thromboplastin time	<b>HRT</b> hormone replacement therapy
<b>ARDS</b> acute respiratory distress syndrome	<b>ICP</b> intracranial pressure
<b>ASA</b> American Society of Anesthesiologists	<b>ICU</b> intensive care unit
<b>AST</b> aspartate aminotransferase	<b>I:E</b> inspiratory:expiratory
<b>ATN</b> acute tubular necrosis	<b>ILM</b> intubating LMA
<b>BLS</b> basic life support	<b>IM</b> intramuscular
<b>BNF</b> British National Formulary	<b>INR</b> international normalized ratio
<b>CAVH</b> continuous arteriovenous haemofiltration	<b>IPPV</b> intermittent positive pressure ventilation
<b>CBF</b> cerebral blood flow	<b>IR</b> immediate release
<b>CCU</b> coronary care unit	<b>ITU</b> intensive therapy unit
<b>CL<sub>CR</sub></b> creatinine clearance	<b>IV</b> intravenous
<b>CNS</b> central nervous system	<b>IVRA</b> intravenous regional anaesthesia
<b>CPD</b> chronic obstructive pulmonary disease	<b>JVP</b> jugular venous pressure
<b>COX</b> cyclo-oxygenase enzymes (COX-1, 2)	<b>LMA</b> laryngeal mask airway
<b>CPAP</b> continuous positive airway pressure	<b>LVEDP</b> left ventricular end-diastolic pressure
<b>CPR</b> cardiopulmonary resuscitation	<b>M6G</b> morphine-6-glucuronide
<b>CSF</b> cerebrospinal fluid	<b>MAC</b> minimum alveolar concentration
<b>CT</b> computerized tomography	<b>MAP</b> mean arterial pressure
<b>CVP</b> central venous pressure	<b>MET</b> Medical Emergency Team
<b>CVS</b> cardiovascular system	<b>MH</b> malignant hyperpyrexia (hyperthermia)
<b>CVVH</b> venovenous haemofiltration	<b>MI</b> myocardial infarction
<b>DIC</b> disseminated intravascular coagulation	<b>MOFS</b> multiple organ failure syndrome
<b>DNAR</b> do not attempt resuscitation	<b>MR</b> modified release
<b>ECF</b> extracellular fluid	<b>MRI</b> magnetic resonance imaging
<b>EMLA</b> eutectic mixture of local anaesthetics	<b>MRSA</b> methicillin-resistant <i>Staphylococcus aureus</i>
<b>ENT</b> ear, nose and throat	<b>NSAID</b> non-steroidal anti-inflammatory drug
<b>FEV<sub>1</sub></b> forced expiratory volume in 1 second	<b>NICE</b> National Institute for Clinical Excellence
<b>FFP</b> fresh frozen plasma	<b>NIPPV</b> non-invasive positive pressure ventilation
<b>FRC</b> functional residual capacity	<b>OCP</b> oral contraceptive pill
<b>FVC</b> forced vital capacity	<b>PAFC</b> pulmonary artery flotation catheter
<b>GCS</b> Glasgow Coma Scale	<b>PCA</b> patient-controlled analgesia
<b>GFR</b> glomerular filtration rate	<b>PCV</b> pressure-controlled ventilation
<b>GGT</b> gamma glutamyl transferase	<b>PEA</b> pulseless electrical activity
	<b>PEEP</b> positive end expiratory pressure



## List of Abbreviations

**PEFR** peak expiratory flow rate  
**PHN** postherpetic neuralgia  
**PMGV** piped medical gas and vacuum system  
**PONV** postoperative nausea and vomiting  
**PT** prothrombin time  
**RS** respiratory system  
**RSI** rapid sequence induction  
**SIMV** synchronized intermittent mandatory ventilation  
**SIRS** systemic inflammatory response syndrome  
**Sp<sub>o</sub><sub>2</sub>** oxygenation of the peripheral tissues  
**SVR** systemic vascular resistance

**TCI** target controlled infusion  
**TENS** transcutaneous electrical nerve stimulation  
**TIVA** total intravenous anaesthesia  
**TNF** tumour necrosis factor  
**TOE** transoesophageal echocardiography  
**TOF** train-of-four  
**TPN** total parenteral nutrition  
**VF** ventricular fibrillation  
**VIE** vacuum-insulated evaporator  
**V/Q** ventilation/perfusion  
**VT** ventricular tachycardia



## Chapter 1

# Anaesthetic assessment and preparation for surgery

### The process of preoperative assessment

By virtue of their training and experience, anaesthetists are uniquely qualified to assess the risks inherent in administering an anaesthetic. In an ideal world, all patients would be seen by their anaesthetist sufficiently ahead of the planned surgery to minimize all risks without interfering with the smooth running of the operating list. Until recently, for elective procedures, this took place when the patient was admitted, usually the day before surgery. This visit also allowed the most suitable anaesthetic technique to be determined, along with an explanation and reassurance for the patient. However, in the presence of any coexisting illness, there would be little time to improve the patient's condition before surgery or to seek advice from other specialists. For these patients, surgery was often postponed and operating time wasted. The recent attempts to improve efficiency by admitting patients on the day of their planned surgical procedure further reduces the opportunity for an adequate anaesthetic assessment. This has led to significant changes in the way patients undergoing elective surgery are managed preoperatively and, more recently, the introduction of clinics specifically for anaesthetic assessment. A variety of models of 'preoperative' or 'anaesthetic assessment' clinics exist; the following is intended as an outline of their functions. Those who require

greater detail are advised to consult the document produced by the Association of Anaesthetists (see Useful websites).

### Stage 1—Screening

Not all patients need to be seen in a preoperative assessment clinic by an anaesthetist. This stage aims to 'filter' patients appropriately. Screening to determine who needs to be seen is achieved by using either a questionnaire or interview, the content of which has been determined with the agreement of the anaesthetic department. The process can be carried out in a number of ways: completion of a questionnaire by the patient, nursing or other staff who have received training, or occasionally by the patient's GP.

The patients screened who *do not need* to attend the preoperative assessment clinic to see an anaesthetist:

- have no coexisting medical problems;
- require no or only baseline investigations, the results of which are within normal limits (see Table 1.2);
- have no potential for, or history of, anaesthetic difficulties;
- require peripheral surgery for which complications are minimal.

On admission these patients will need to be formally clerked and examined by a member of the surgical team.

The most obvious type of patient who fits into this class are those scheduled for day case (ambulatory) surgery. These patients should be seen at the time of admission by the anaesthetist, who will:

- confirm the findings of the screening;
- check the results of any baseline investigations;
- explain the type of anaesthetic appropriate for the procedure;
- have the ultimate responsibility for deciding it is safe to proceed.

## **Stage 2—The preoperative assessment clinic**

The patients seen here are those who have been identified by the screening process as having coexisting medical problems that:

- are well controlled with medical treatment;
- are previously undiagnosed, for example diabetes, hypertension;
- are less than optimally managed, for example hypertension, angina;
- have abnormal baseline investigations;
- show a need for further investigations, for example pulmonary function tests, echocardiography;
- indicate previous anaesthetic difficulties, for example difficult intubation;
- suggest potential anaesthetic difficulties, for example obesity, previous or family history of prolonged apnoea after anaesthesia;
- are to undergo complex surgery with or without planned admission to the intensive therapy unit (ITU) postoperatively.

Once again, not all these patients will need to be seen by an anaesthetist in the clinic, although it is essential that anaesthetic advice from a senior anaesthetist is readily available. Those who *may not need to be seen* by an anaesthetist include:

- Patients with well-controlled concurrent medical conditions, for example hypertension, asthma. They may need additional investigations that can be ordered according to an agreed protocol and then re-assessed.
- Patients with previously undiagnosed or less than optimally managed medical problems. They can be referred to the appropriate specialist at this stage and then re-assessed.

Nurses who have been specifically trained are participating increasingly in the preparation of these patients, by taking a history, performing an examination and ordering appropriate investigations (see below). Alternatively it may be a member of the surgical team.

The patients, who *will need to be seen* by the anaesthetist, are those identified for whatever reason as having actual or potential anaesthetic problems. This is often symptomatic concurrent disease despite optimal treatment, or previous or potential anaesthetic problems. Patients may also have been deferred initially for review by a medical specialist, for example cardiologist, to optimize medical treatment. This allows the anaesthetist to:

- make a full assessment of the patient's medical condition;
- review any previous anaesthetics administered;
- evaluate the results of any investigations;
- request any additional investigations;
- explain and document:
  - the anaesthetic options available and the potential side-effects;
  - the risks associated with anaesthesia;
- discuss plans for postoperative care.

The ultimate aim is to ensure that when the patient is admitted for surgery, the chances of being cancelled as a result of 'unfit for anaesthesia' are minimized. Clearly the time between the patient being seen in the assessment clinic and the date admitted for surgery cannot be excessive, and is generally between 4 and 6 weeks.

## **The anaesthetic assessment**

Whoever is responsible for the anaesthetic assessment must take a full history, examine each patient and ensure that appropriate investigations are carried out. When performed by non-anaesthetic staff, a protocol is often used to ensure all the relevant areas are covered. This section concentrates on features of particular relevance to the anaesthetist.

## Present and past medical history

Of all the aspects of the patient's medical history, those relating to the cardiovascular and respiratory systems are relatively more important.

### Cardiovascular system

Symptoms of the following problems must be sought in all patients:

- ischaemic heart disease;
- heart failure;
- hypertension;
- conduction defects, arrhythmias;
- peripheral vascular disease.

Patients with a proven history of myocardial infarction (MI) are at a greater risk of perioperative reinfarction, the incidence of which is related to the time interval between infarct and surgery. This time is variable. In a patient with an uncomplicated MI and a normal exercise test elective surgery may only need to be delayed by 6–8 weeks. The American Heart Association has produced guidance for perioperative cardiovascular evaluation (see Useful websites).

Heart failure is one of the most significant indi-

cators of perioperative complications, associated with increased risk of perioperative cardiac morbidity and mortality. Its severity is best described using a recognized scale, for example the New York Heart Association classification (Table 1.1).

Untreated or poorly controlled hypertension may lead to exaggerated cardiovascular responses during anaesthesia. Both hypertension and hypotension can be precipitated, which increase the risk of myocardial and cerebral ischaemia. The severity of hypertension will determine the action required:

- *Mild (SBP 140–159 mmHg, DBP 90–99 mmHg)* No evidence that delaying surgery for treatment affects outcome.
- *Moderate (SBP 160–179 mmHg, DBP 100–109 mmHg)* Consider review of treatment. If unchanged, requires close monitoring to avoid swings during anaesthesia and surgery.
- *Severe (SBP > 180 mmHg, DBP > 109 mmHg)* At this level, elective surgery should be postponed due to the significant risk of myocardial ischaemia, arrhythmias and intracerebral haemorrhage. In an emergency, will require acute control with invasive monitoring.

**Table 1.1** New York Heart Association classification of cardiac function compared to Specific Activity Scale

NYHA functional classification	Specific Activity Scale classification
Class I: Cardiac disease without limitation of physical activity No fatigue, palpitations, dyspnoea or angina	Can perform activities requiring $\geq 7$ mets Jog/walk at 5 mph, ski, play squash or basketball, shovel soil
Class II: Cardiac disease resulting in slight limitation of physical activity Asymptomatic at rest, ordinary physical activity causes fatigue, palpitations, dyspnoea or angina	Can perform activities requiring $\geq 5$ but $< 7$ mets Walk at 4 mph on level ground, garden, rake, weed, have sexual intercourse without stopping
Class III: Cardiac disease causing marked limitation of physical activity Asymptomatic at rest, less than ordinary activity causes fatigue, palpitations, dyspnoea or angina	Can perform activities requiring $\geq 2$ but $< 5$ mets Perform most household chores, play golf, push the lawnmower, shower
Class IV: Cardiac disease limiting any physical activity Symptoms of heart failure or angina at rest, increased with any physical activity	Patients cannot perform activities requiring $\geq 2$ mets Cannot dress without stopping because of symptoms; cannot perform any class III activities

## Respiratory system

Enquire specifically about symptoms of:

- chronic obstructive lung disease;
- emphysema;
- asthma;
- infection;
- restrictive lung disease.

Patients with pre-existing lung disease are more prone to postoperative chest infections, particularly if they are also obese, or undergoing upper abdominal or thoracic surgery. If an acute upper respiratory tract infection is present, anaesthesia and surgery should be postponed unless it is for a life-threatening condition.

## Assessment of exercise tolerance

An indication of cardiac and respiratory reserves can be obtained by asking the patient about their ability to perform everyday physical activities before having to stop because of symptoms of chest pain, shortness of breath, etc. For example:

- How far can you walk on the flat?
- How far can you walk uphill?
- How many stairs can you climb before stopping?
- Could you run for a bus?
- Are you able to do the shopping?
- Are you able to do housework?
- Are you able to care for yourself?

The problem with such questions is that they are very subjective and patients often tend to overestimate their abilities!

## How can this be made more objective?

The New York Heart Association (NYHA) Classification of function is one system, but even this uses some subjective terms such as 'ordinary' and 'slight'. The Specific Activity Scale grades common physical activities in terms of their metabolic equivalents of activity or 'mets', and classifies patients on how many mets they can achieve. The two classifications are shown for comparison in Table 1.1. Unfortunately, not all patients can be assessed in this way; for example those with severe musculoskeletal dysfunction may not be able to exercise to the limit of their cardiorespiratory re-

serve. In such circumstances other methods of assessment are required. The most readily available method of non-invasive assessment of cardiac function in patients is some type of echocardiography (see below).

Other conditions which are important if identified in the medical history:

- *Indigestion, heartburn and reflux* Possibility of a hiatus hernia. If exacerbated on bending forward or lying flat, this increases the risk of regurgitation and aspiration.
- *Rheumatoid disease* Limited movement of joints makes positioning for surgery difficult. Cervical spine and temporomandibular joint involvement may complicate airway management. There is often a chronic anaemia.
- *Diabetes* An increased incidence of ischaemic heart disease, renal dysfunction, and autonomic and peripheral neuropathy. Increased risk of intra- and postoperative complications, particularly hypotension and infections.
- *Neuromuscular disorders* Coexisting heart disease may be worsened by anaesthesia and restrictive pulmonary disease (forced vital capacity (FVC) < 1 L) predisposes to chest infection and the possibility of the need for ventilatory support postoperatively. Care when using muscle relaxants.
- *Chronic renal failure* Anaemia and electrolyte abnormalities. Altered drug excretion restricts the choice of anaesthetic drugs. Surgery and dialysis treatments need to be coordinated.
- *Jaundice* Altered drug metabolism, coagulopathy. Care with opioid administration.
- *Epilepsy* Well-controlled epilepsy is not a major problem. Avoid anaesthetic drugs that are potentially epileptogenic (e.g. enflurane; see Table 2.4).

## Previous anaesthetics and operations

These may have occurred in hospitals or, less commonly, dental surgeries. Enquire about any difficulties, for example: nausea, vomiting, dreams, awareness, postoperative jaundice. Check the records of previous anaesthetics to rule out or clarify problems such as difficulties with intubation, allergy to drugs given, or adverse reactions (e.g. malignant hyperpyrexia, see below). Some

patients may have been issued with a 'Medic Alert' type bracelet or similar device giving details or a contact number. Although halothane is now less popular for maintenance of anaesthesia, the approximate date of previous anaesthetics should be identified if possible to avoid the risk of repeat exposure (see page 33). Details of previous surgery may reveal potential anaesthetic problems, for example cardiac, pulmonary or cervical spine surgery.

## Family history

All patients should be asked whether there are any known inherited conditions in the family (e.g. sickle-cell disease, porphyria). Have any family members experienced problems with anaesthesia; a history of prolonged apnoea suggests pseudocholinesterase deficiency (see page 34), and an unexplained death malignant hyperpyrexia (see page 98). Elective surgery should be postponed if any conditions are identified, and the patient investigated appropriately. In the emergency situation, anaesthesia must be adjusted accordingly, for example by avoidance of triggering drugs in a patient with a family history of malignant hyperpyrexia.

## Drug history and allergies

Identify all medications, both prescribed and self-administered, including herbal preparations. Patients will often forget about the oral contraceptive pill (OCP) and hormone replacement therapy (HRT) unless specifically asked. The incidence of use of medications rises with age and many of these drugs have important interactions with anaesthetics. A current British National Formulary (BNF), or the BNF website, should be consulted for lists of the more common and important ones. Allergies to drugs, topical preparations (e.g. iodine), adhesive dressings and foodstuffs should be noted.

## Social history

- *Smoking* Ascertain the number of cigarettes or the amount of tobacco smoked per day. Oxygen car-

riage is reduced by carboxyhaemoglobin, and nicotine stimulates the sympathetic nervous system, causing tachycardia, hypertension and coronary artery narrowing. Apart from the risks of chronic lung disease and carcinoma, smokers have a significantly increased risk of postoperative chest infections. Stopping smoking for 8 weeks improves the airways; for 2 weeks reduces their irritability; and for as little as 24 h before anaesthesia decreases carboxyhaemoglobin levels. Help and advice should be available at the preoperative assessment clinic.

- *Alcohol* This is measured as units consumed per week; >50 units/week causes induction of liver enzymes and tolerance to anaesthetic drugs. The risk of alcohol withdrawal syndrome postoperatively must be considered.

- *Drugs* Ask specifically about the use of drugs for recreational purposes, including type, frequency and route of administration. This group of patients is at risk of infection with hepatitis B and human immunodeficiency virus (HIV). There can be difficulty with venous access following IV drug abuse due to widespread thrombosis of veins. Withdrawal syndromes can occur postoperatively.

- *Pregnancy* The date of the last menstrual period should be noted in all women of childbearing age. The anaesthetist may be the only person in theatre able to give this information if X-rays are required. Anaesthesia increases the risk of inducing a spontaneous abortion in early pregnancy. There is an increased risk of regurgitation and aspiration in late pregnancy. Elective surgery is best postponed until after delivery.

## The examination

As with the history, this concentrates on the cardiovascular and respiratory systems; the remaining systems are examined if problems relevant to anaesthesia have been identified in the history. At the end of the examination, the patient's airway is assessed to try and identify any potential problems. If a regional anaesthetic is planned, the appropriate anatomy (e.g. lumbar spine for central neural block) is examined.

## Cardiovascular system

Look specifically for signs of:

- arrhythmias;
- heart failure;
- hypertension;
- valvular heart disease;
- peripheral vascular disease.

Don't forget to inspect the peripheral veins to identify any potential problems with IV access.

## Respiratory system

Look specifically for signs of:

- respiratory failure;
- impaired ventilation;
- collapse, consolidation, pleural effusion;
- additional or absent breath sounds.

## Nervous system

Chronic disease of the peripheral and central nervous systems should be identified and any evidence of motor or sensory impairment recorded. It must be remembered that some disorders will affect the cardiovascular and respiratory systems, for example dystrophia myotonica and multiple sclerosis.

## Musculoskeletal system

Patients with connective tissue disorders should have any restriction of movement and deformities noted. Patients suffering from chronic rheumatoid disease frequently have a reduced muscle mass, peripheral neuropathies and pulmonary involvement. Particular attention should be paid to the patient's cervical spine and temporomandibular joints (see below).

## The airway

All patients must have an assessment made of their airway, the aim being to try and predict those patients who may be difficult to intubate.

## Observation of the patient's anatomy

Look for:

- limitation of mouth opening;
- a receding mandible;
- position, number and health of teeth;
- size of the tongue;
- soft tissue swelling at the front of the neck;
- deviation of the larynx or trachea;
- limitations in flexion and extension of the cervical spine.

Finding any of these suggests that intubation may be more difficult. However, it must be remembered that all of these are subjective.

## Simple bedside tests

- *Mallampati criteria* The patient, sitting upright, is asked to open their mouth and maximally protrude their tongue. The view of the pharyngeal structures is noted and graded I-IV (Fig. 1.1). Grades III and IV suggest difficult intubation.

- *Thyromental distance* With the head fully extended on the neck, the distance between the bony point of the chin and the prominence of the thyroid cartilage is measured (Fig. 1.2). A distance of less than 7 cm suggests difficult intubation.

- *Wilson score* Increasing weight, a reduction in head and neck movement, reduced mouth opening, and the presence of a receding mandible or buck-teeth all predispose to increased difficulty with intubation.

- *Calder test* The patient is asked to protrude the mandible as far as possible. The lower incisors will lie either anterior to, aligned with or posterior to the upper incisors. The latter two suggest reduced view at laryngoscopy.

None of these tests, alone or in combination, predicts all difficult intubations. A Mallampati grade III or IV with a thyromental distance of <7 cm predicts 80% of difficult intubations. If problems are anticipated, anaesthesia should be planned accordingly. If intubation proves to be difficult, it must be recorded in a prominent place in the patient's notes and the patient informed.



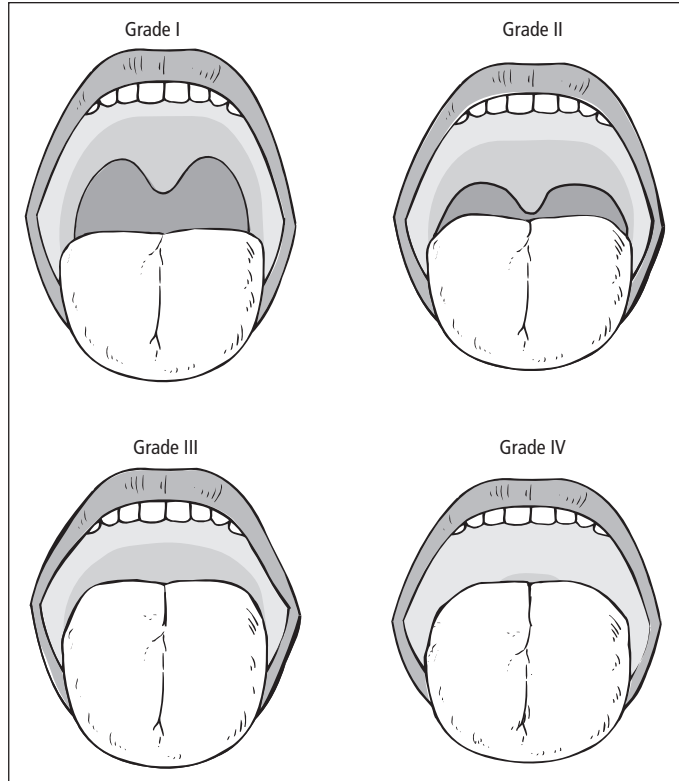

**Figure 1.1** The pharyngeal structures seen during the Mallampati assessment.

## Investigations

There is little evidence to support the performance of ‘routine’ investigations, and these should only be ordered if the result would affect the patient’s management. *In patients with no evidence of concurrent disease* (ASA 1, see below), preoperative investigations will depend on the extent of surgery and the age of the patient. A synopsis of the current guidelines for these patients, issued by the National Institute for Clinical Excellence (NICE), is shown in Table 1.2. For each age group and grade of surgery, the upper entry, shows ‘tests recommended’ and the lower entry ‘tests to be considered’ (depending on patient characteristics). Dipstick urinalysis need only be performed in symptomatic individuals.

## Additional investigations

The following is a guide to those commonly requested. Again these will also be dependent on the grade of surgery and the age of the patient. Further information can be found in Clinical Guideline 3, published by NICE (see Useful websites).

- **Urea and electrolytes:** patients taking digoxin, diuretics, steroids, and those with diabetes, renal disease, vomiting, diarrhoea.
- **Liver function tests:** known hepatic disease, a history of a high alcohol intake (>50 units/week), metastatic disease or evidence of malnutrition.
- **Blood sugar:** diabetics, severe peripheral arterial disease or taking long-term steroids.
- **Electrocardiogram (ECG):** hypertensive, with symptoms or signs of ischaemic heart disease, a cardiac arrhythmia or diabetics >40 years of age.
- **Chest X-ray:** symptoms or signs of cardiac or respiratory disease, or suspected or known

malignancy, where thoracic surgery is planned, or in those from areas of endemic tuberculosis who have not had a chest X-ray in the last year.

- *Pulmonary function tests:* dyspnoea on mild exertion, chronic obstructive pulmonary disease

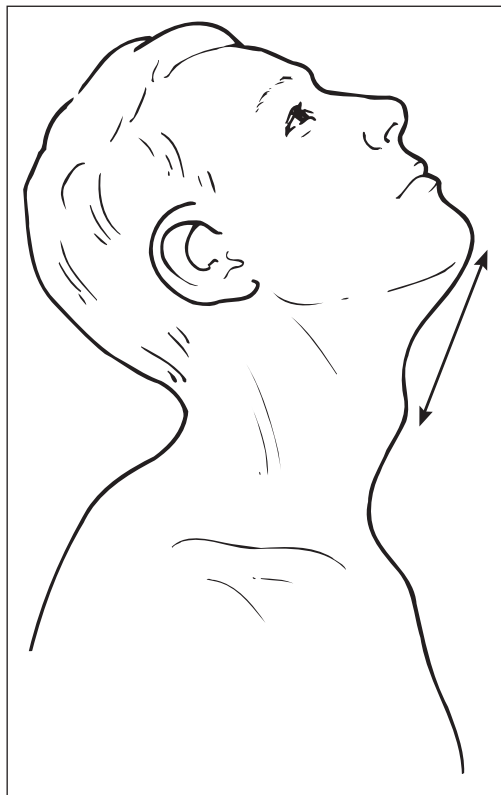

Figure 1.2 The thyromental distance.

(COPD) or asthma. Measure peak expiratory flow rate (PEFR), forced expiratory volume in 1 s (FEV<sub>1</sub>) and FVC. Patients who are dyspnoeic or cyanosed at rest, found to have an FEV<sub>1</sub> <60% predicted, or are to have thoracic surgery, should also have arterial blood gas analysed while breathing air.

- *Coagulation screen:* anticoagulation, a history of a bleeding diatheses or a history of liver disease or jaundice.
- *Sickle-cell screen (Sickledex):* a family history of sickle-cell disease or where ethnicity increases the risk of sickle-cell disease. If positive, electrophoresis for definitive diagnosis.
- *Cervical spine X-ray:* rheumatoid arthritis, a history of major trauma or surgery to the neck or when difficult intubation is predicted.

### Echocardiography

This is becoming increasingly recognized as a useful tool to assess left ventricular function in patients with ischaemic or valvular heart disease, but whose exercise ability is limited, for example by severe osteoarthritis. The ejection fraction and contractility can be calculated and any ventricular wall motion abnormalities identified. Similarly, ventricular function post-myocardial infarction can be assessed. In patients with valvular lesions, the degree of dysfunction can be assessed. In aortic stenosis an estimate of the pressure gradient across the valve is a good indication of the severity of the disease. As an echocardiogram is performed in

Table 1.2 Baseline investigations in patients with no evidence of concurrent disease (ASA 1)

Age of patient	Minor surgery	Intermediate surgery	Major surgery	Major 'plus' surgery
16–39	Nil	Nil	FBC	FBC, RFT
Consider	Nil	Nil	RFT, BS	Clotting, BS
40–59	Nil	Nil	FBC	FBC, RFT
Consider	ECG	ECG, FBC, BS	ECG, BS, RFT	ECG, BS, clotting
60–79	Nil	FBC	FBC, ECG, RFT	FBC, RFT, ECG
Consider	ECG	ECG, BS, RFT	BS, CXR	BS, clotting, CXR
≥80	ECG	FBC, ECG	FBC, ECG, RFT	FBC, RFT, ECG
Consider	FBC, RFT	RFT, BS	BS, CXR, clotting	BS, clotting, CXR

FBC: full blood count; RFT: renal function tests, to include sodium, potassium, urea and creatinine; ECG: electrocardiogram; BS: random blood glucose; CXR: chest X-ray. Clotting to include prothrombin time (PT), activated partial thromboplastin time (APTT), international normalized ratio (INR). Courtesy of National Institute for Clinical Excellence.

patients at rest, it does not give any indication of what happens under stress. A stress echocardiogram can be performed during which drugs are given to increase heart rate and myocardial work, simulating the conditions the patient may encounter, while monitoring changes in myocardial performance. For example the inotrope dobutamine acts as a substitute for exercise whilst monitoring the ECG for ischaemic changes (dobutamine stress echocardiography).

### Medical referral

Patients with coexisting medical (or surgical) conditions that require advice from other specialists should have been identified in the preoperative assessment clinic, not on the day of admission. Clearly a wide spectrum of conditions exist; the following are examples of some of the more commonly encountered.

#### Cardiovascular disease

- Untreated or poorly controlled hypertension or heart failure.
- Symptomatic ischaemic heart disease, despite treatment (unstable angina).
- Arrhythmias: uncontrolled atrial fibrillation, paroxysmal supraventricular tachycardia, and second and third degree heart block.
- Symptomatic or newly diagnosed valvular heart disease, or congenital heart disease.

#### Respiratory disease

- Chronic obstructive pulmonary disease, particularly if dyspnoeic at rest.
- Bronchiectasis.
- Asthmatics who are unstable, taking oral steroids or have a FEV<sub>1</sub> <60% predicted.

#### Endocrine disorders

- Insulin and non-insulin dependent diabetics who have ketonuria, glycated Hb (HbA1c) >10% or a random blood sugar >12 mmol/L. Local policy will dictate referral of stable diabetics for perioperative management.
- Hypo- or hyperthyroidism symptomatic on current treatment.

- Cushing's or Addison's disease.
- Hypopituitarism.

#### Renal disease

- Chronic renal failure.
- Patients undergoing renal replacement therapy.

#### Haematological disorders

- Bleeding diatheses, for example haemophilia, thrombocytopenia.
- Therapeutic anticoagulation.
- Haemoglobinopathies.
- Polycythaemia.
- Haemolytic anaemias.
- Leukaemias.

### Risk associated with anaesthesia and surgery

At the end of the day the question that patients ask is '*Doctor, what are the risks of having an anaesthetic?*' These can be divided into two main groups.

#### Minor

These are not life threatening and can occur even when anaesthesia has apparently been uneventful. Although classed as minor, the patient may not share this view. They include:

- failed IV access;
- cut lip, damage to teeth, caps, crowns;
- sore throat;
- headache;
- postoperative nausea and vomiting;
- retention of urine.

#### Major

These may be life-threatening events. They include:

- aspiration of gastric contents;
- hypoxic brain injury;
- myocardial infarction;
- cerebrovascular accident;
- nerve injury;
- chest infection.

In the United Kingdom, the Confidential Enquiry

**Table 1.3** ASA physical status scale

Class	Physical status	Absolute mortality (%)
I	A healthy patient with no organic or psychological disease process. The pathological process for which the operation is being performed is localized and causes no systemic upset	0.1
II	A patient with a mild to moderate systemic disease process, caused by the condition to be treated surgically or another pathological process, that does not limit the patient's activities in any way; e.g. treated hypertensive, stable diabetic. Patients aged >80 years are automatically placed in class II	0.2
III	A patient with severe systemic disease from any cause that imposes a definite functional limitation on activity; e.g. ischaemic heart disease, chronic obstructive lung disease	1.8
IV	A patient with a severe systemic disease that is a constant threat to life, e.g. unstable angina	7.8
V	A moribund patient unlikely to survive 24h with or without surgery	9.4

Note: 'E' may be added to signify an emergency operation.

into Perioperative Deaths (CEPOD 1987) revealed an *overall* perioperative mortality of 0.7% in approximately 500000 operations. Anaesthesia was considered to have been a contributing factor in 410 deaths (0.08%), but was judged *completely* responsible in only three cases—a primary mortality rate of 1:185000 operations. When the deaths where anaesthesia contributed were analysed, the predominant factor was human error.

Clearly, anaesthesia itself is very safe, particularly in those patients who are otherwise well. Apart from human error, the most likely risk is from an adverse drug reaction or drug interaction. However, anaesthesia rarely occurs in isolation and when the risks of the surgical procedure and those due to pre-existing disease are combined, the risks of morbidity and mortality are increased. Not surprisingly a number of methods have been described to try and quantify these risks.

### Risk indicators

The most widely used scale for estimating risk is the American Society of Anesthesiologists (ASA) classification of the patient's physical status. The patient is assigned to one of five categories depending on any physical disturbance caused by either pre-existing disease or the process for which surgery is being performed. It is relatively subjective and does not take into account the type of sur-

gery being undertaken, which leads to a degree of inter-rater variability. However, patients placed in higher categories are at increased overall risk of perioperative mortality (Table 1.3).

### Multifactorial risk indicators

The leading cause of death after surgery is myocardial infarction, and there is significant morbidity from non-fatal infarction, particularly in those patients with pre-existing heart disease. Not surprisingly, attempts have been made to identify factors that will predict those at risk. One system is the Goldman Cardiac Risk Index, used in patients with pre-existing cardiac disease undergoing non-cardiac surgery. Using their history, examination, ECG findings, general status and type of surgery, points are awarded in each category (Table 1.4).

The points total is used to assign the patient to one of four classes; the risks of a perioperative cardiac event, including myocardial infarction, pulmonary oedema, significant arrhythmia and death are:

- class I (0–5 points) 1%
- class II (6–12 points) 5%
- class III (13–25 points) 16%
- class IV (≥26 points) 56%

This has been shown to be a more accurate predictor than the ASA classification.

**Table 1.4** Goldman Cardiac Risk Index

	<b>Points</b>
<i>History</i>	
Age >70 years	5
Myocardial infarction within 6 months	10
<i>Examination</i>	
Third heart sound (gallop rhythm), raised JVP	11
Significant aortic stenosis	3
<i>ECG</i>	
Rhythm other than sinus, or presence of premature atrial complexes	7
>5 ventricular ectopics per minute	7
<i>General condition</i>	
$P_{aO_2} < 8$ kPa or $P_{aCO_2} > 7.5$ kPa on air	
$K^+ < 3.0$ mmol/L; $HCO_3^- < 20$ mmol/L	
Urea $> 8.5$ mmol/L; creatinine $> 200$ mmol/L	
Chronic liver disease	
Bedridden from non-cardiac cause	
<i>For each criterion</i>	3
<i>Operation</i>	
Intraperitoneal, intrathoracic, aortic	3
Emergency surgery	4

JVP: jugular venous pressure.

**Table 1.5** Overall approximate risk (%) of major cardiac complication based on type of surgery and patient's cardiac risk index

<i>Grade of surgery</i>	<b>Patient risk index score</b>			
	Class I (0–5 points)	Class II (6–12 points)	Class III (13–25 points)	Class IV (>26 points)
Minor surgery	0.3	1	3	19
Major non-cardiac surgery, >40 years	1.2	4	12	48
Major non-cardiac surgery, >40 years, significant medical problem requiring consultation before surgery	3	10	30	75

Apart from any risk as a result of pre-existing cardiac disease, the type of surgery the patient is undergoing will also have its own inherent risks; carpal tunnel decompression will carry less risk than a hip replacement, which in turn will be less risky than aortic aneurysm surgery. In other words, the sicker the patient and the bigger the operation, the greater the risk. This is clearly demonstrated in

Table 1.5. Major cardiac complication includes myocardial infarction, cardiogenic pulmonary oedema, ventricular tachycardia or cardiac death.

Assessing a patient as 'low risk' is no more of a guarantee that complications will not occur than 'high risk' means they will occur; it is only a guideline and indicator of probability. For the patient who suffers a complication the rate is 100%!

Ultimately it is the risk/benefit ratio that must be considered for each patient; for a given risk, it is more sensible to proceed with surgery that offers the greatest benefit.

Further reductions in the perioperative mortality of patients have been shown to result from improving preoperative preparation by optimizing the patient's physical status, adequately resuscitating those who require emergency surgery, monitoring appropriately intraoperatively, and by providing suitable postoperative care in a high dependency unit (HDU) or intensive care unit (ICU).

### Classification of operation

Traditionally, surgery was classified as being either elective or emergency. Recognizing that this was too imprecise, the National Confidential Enquiry into Perioperative Deaths (NCEPOD) devised four categories:

- *Elective*: operation at a time to suit both patient and surgeon; for example hip replacement, varicose veins.
- *Scheduled*: an early operation but not immediately life saving; operation usually within 3 weeks; for example surgery for malignancy.
- *Urgent*: operation as soon as possible after resuscitation and within 24 h; for example intestinal obstruction, major fractures.
- *Emergency*: immediate life-saving operation, resuscitation simultaneous with surgical treatment; operation usually within 1 h; for example major trauma with uncontrolled haemorrhage, extradural haematoma.

All elective and the majority of scheduled cases can be assessed as described above. However, with urgent cases this will not always be possible; as much information as possible should be obtained about any concurrent medical problems and their treatment, and allergies and previous anaesthetics. The cardiovascular and respiratory systems should be examined and an assessment made of any potential difficulty with intubation. Investigations should only be ordered if they would directly affect the conduct of anaesthesia. With true emergency cases there will be even less or no time for assessment. Where possible an attempt should be made

to establish the patient's medical history, drugs taken regularly and allergies. In the trauma patient enquire about the mechanism of injury. All emergency patients should be assumed to have a full stomach. Details may only be available from relatives and/or the ambulance crew.

## Informing the patient and consent

### What is consent?

It is an agreement by the patient to undergo a specific procedure. Only the patient can make the decision to undergo the procedure, even though the doctor will advise on what is required. Although the need for consent is usually thought of in terms of surgery, in fact it is required for any breach of a patient's personal integrity, including examination, performing investigations and administering an anaesthetic. A patient can refuse treatment or choose a less than optimal option from a range offered (providing an appropriate explanation has been given—see below), but he or she cannot insist on treatment that is not on offer.

### What about an unconscious patient?

This usually arises in the emergency situation, for example a patient with a severe head injury. Asking a relative or other individual to sign a consent form for surgery on the patient's behalf is not appropriate, as no one can give consent on behalf of another adult. Under these circumstances medical staff are required to act 'in the patient's best interests'. This will mean taking into account not only the benefits of the proposed treatment, but also any views previously expressed by the patient (e.g. refusal of blood transfusion by a Jehovah's Witness). This will often require discussion with the relatives, and this opportunity should be used to inform them of the proposed treatment and the rationale for it. All decisions and discussions must be clearly documented in the patient's notes. Where treatment decisions are complex or not clear cut, it is advisable to obtain and document independent medical advice.

## What constitutes evidence of consent?

Most patients will be asked to sign a consent form before undergoing a procedure. However, there is no legal requirement for such before anaesthesia or surgery (or anything else); the form simply shows evidence of consent at the time it was signed. Consent may be given verbally and this is often the case in anaesthesia. It is recommended that a written record of the content of the conversation be made in the patient's case notes.

## What do I have to tell the patient?

In obtaining consent it is essential the patient is given an adequate amount of information in a form that they can understand. This will vary depending on the procedure, but may include:

- The environment of the anaesthetic room and who they will meet, particularly if medical students or other healthcare professionals in training will be present.
- Establishing intravenous access and IV infusion.
- The need for, and type of, any invasive monitoring.
- What to expect during the establishment of a regional technique.
- Being conscious throughout surgery if a regional technique alone is used, and what they may hear.
- Preoxygenation.
- Induction of anaesthesia. Although most commonly intravenous, occasionally it may be by inhalation.
- Where they will 'wake up'. This is usually the recovery unit, but after some surgery it may be the ICU or HDU. In these circumstances the patient should be given the opportunity to visit the unit a few days before and meet some of the staff.
- Numbness and loss of movement after regional anaesthesia.
- The possibility of drains, catheters and drips. Their presence may be misinterpreted by the patient as indicating unexpected problems.
- The possibility of a need for blood transfusion.
- Postoperative pain control, particularly if it re-

quires their co-operation; for example a patient-controlled analgesia device (see page 84).

- Information on any substantial risks with serious adverse consequences associated with the anaesthetic technique planned.

Although the anaesthetist will be the best judge of the type of anaesthetic for each individual, patients should be given an explanation of the choices, along with the associated benefits and risks in terms they can understand. Most patients will have an understanding of general anaesthesia—the injection of a drug, followed by loss of consciousness and lack of awareness throughout the surgical procedure. If regional anaesthesia is proposed, it is essential that the patient understands and accepts that remaining conscious throughout is to be expected, unless some form of sedation is to be used.

Most patients will want to know when they can last eat and drink before surgery, if they are to take normal medications and how they will manage without a drink. Some will expect or request a premed and in these circumstances the approximate timing, route of administration and likely effects should be discussed.

Finally, before leaving ask if the patient has any questions or wants anything clarified further.

## Who should get consent?

From the above it is clear that the individual seeking consent must be able to provide the necessary information for the patient and be able to answer the patient's questions. This will require the individual to be trained in, and familiar with, the procedure for which consent is sought, and is best done by a senior clinician or the person who is to perform the procedure. With complex problems consent may require a multidisciplinary approach.

The issues around consent in children and adults who lack capacity are more complex, and the reader should consult the Useful websites section for more information.

## Useful websites

[http://www.aagbi.org/pdf/pre-operative\\_ass.pdf](http://www.aagbi.org/pdf/pre-operative_ass.pdf)  
[Preoperative assessment. The role of the anaes-

**Chapter 1** Anaesthetic assessment and preparation for surgery

- thetist. The Association of Anaesthetists of Great Britain and Ireland. November 2001.]  
<http://www.americanheart.org/presenter.jhtml?identifier=3000370>  
[American College of Cardiology / American Heart Association (ACC/AHA) Guideline Update on Perioperative Cardiovascular Evaluation for Noncardiac Surgery. 2002.]  
[http://www.nice.org.uk/pdf/Preop\\_Fullguideline.pdf](http://www.nice.org.uk/pdf/Preop_Fullguideline.pdf)  
[National Institute for Clinical Excellence (NICE) guidance on preoperative tests. June 2003.]  
<http://info.med.yale.edu/intmed/cardio/imaging/contents.html>  
[Chest X-ray interpretation.]
- <http://www.ncepod.org.uk/dhome.htm>  
[Confidential Enquiry into Perioperative Deaths (CEPOD).]  
<http://www.doh.gov.uk/consent/index.htm>  
[Department of Health (UK) guidance on consent.]  
<http://www.bma.org.uk/ap.nsf/Content/consenttk2>  
[BMA consent toolkit, second edition. February 2003.]  
<http://www.youranaesthetic.info/>  
[http://www.aagbi.org/pub\\_patient.html#KNOW](http://www.aagbi.org/pub_patient.html#KNOW)  
[Patient information guides from the Association of Anaesthetists of Great Britain and Ireland and The Royal College of Anaesthetists.]  
<http://www.BNF.org>  
[British National Formulary.]



## Chapter 2

# Anaesthesia

### Premedication

Premedication originally referred to drugs administered to facilitate the induction and maintenance of anaesthesia (literally, preliminary medication). Nowadays, premedication refers to the administration of any drugs in the period before induction of anaesthesia. Consequently, a wide variety of drugs are used with a variety of aims, summarized in Table 2.1.

### Anxiolysis

The most commonly prescribed drugs are the benzodiazepines. They produce a degree of sedation and amnesia, are well absorbed from the gastrointestinal tract and are usually given orally, 45–90 mins preoperatively. Those most commonly used include temazepam 20–30 mg, diazepam 10–20 mg and lorazepam 2–4 mg. In patients who suffer from excessive somatic manifestations of anxiety, for example tachycardia, beta blockers may be given. A preoperative visit and explanation is often as effective as drugs at alleviating anxiety, and sedation does not always mean lack of anxiety.

### Amnesia

Some patients specifically request that they not have any recall of the events leading up to anaesthesia and surgery. This may be accomplished by

the administration of lorazepam (as above) to provide anterograde amnesia.

### Anti-emetic (reduction of nausea and vomiting)

Nausea and vomiting may follow the administration of opioids, either pre- or intraoperatively. Certain types of surgery are associated with a higher incidence of postoperative nausea and vomiting (PONV), for example gynaecology. Unfortunately, none of the currently used drugs can be relied on to prevent or treat established PONV. Drugs with anti-emetic properties are shown in Table 2.2.

### Antacid (modify pH and volume of gastric contents)

Patients are starved preoperatively to reduce the risk of regurgitation and aspiration of gastric acid at the induction of anaesthesia (see below). This may not be possible or effective in some patients:

- those who require emergency surgery;
- those who have received opiates or are in pain will show a significant delay in gastric emptying;
- those with a hiatus hernia, who are at an increased risk of regurgitation.

A variety of drug combinations are used to try and increase the pH and reduce the volume.

- *Oral sodium citrate (0.3M)*: 30 mL orally immediately preinduction, to chemically neutralize residual acid.
- *Ranitidine (H<sub>2</sub> antagonist)*: 150 mg orally 12 hourly and 2 hourly preoperatively.
- *Metoclopramide*: 10 mg orally preoperatively. Increases both gastric emptying and lower oesophageal sphincter tone. Often given in conjunction with ranitidine.
- *Omeprazole (proton pump inhibitor)*: 40 mg 3–4 hourly preoperatively.

If a naso- or orogastric tube is in place, this can be used to aspirate gastric contents.

### Anti-autonomic effects

#### Anticholinergic effects

(a) Reduce salivation (antisialogogue), for example during fiberoptic intubation, surgery or instrumentation of the oral cavity or ketamine anaesthesia.

(b) Reduce the vagolytic effects on the heart, for example before the use of suxamethonium (particularly in children), during surgery on the extra ocular muscles (squint correction), or during elevation of a fractured zygoma. Atropine and hyoscine have now largely been replaced pre-

operatively by glycopyrrolate, 0.2–0.4 mg intramuscularly (IM). Many anaesthetists would consider an IV dose given at induction more effective.

### Antisymphathomimetic effects

Increased sympathetic activity can be seen at intubation, causing tachycardia and hypertension. This is undesirable in certain patients, for example those with ischaemic heart disease or raised intracranial pressure. These responses can be attenuated by the use of beta blockers given preoperatively (e.g. atenolol, 25–50 mg orally) or intravenously at induction (e.g. esmolol). Perioperative beta blockade may also decrease the incidence of adverse coronary events in high risk patients having major surgery. An alternative is to give a potent analgesic at induction of anaesthesia, for example fentanyl, alfentanil or remifentanil.

### Analgesia

Although the oldest form of premedication, analgesic drugs are now generally reserved for patients who are in pain preoperatively. The most commonly used are morphine, pethidine and fentanyl. Morphine was widely used for its sedative effects but is relatively poor as an anxiolytic and has largely been replaced by the benzodiazepines. Opiates have a range of unwanted side-effects, including nausea, vomiting, respiratory depression and delayed gastric emptying.

### Miscellaneous

A variety of other drugs are commonly given prophylactically before anaesthesia and surgery; for example:

**Table 2.1** The 6 As of premedication

- Anxiolysis
- Amnesia
- Anti-emetic
- Antacid
- Anti-autonomic
- Analgesia

**Table 2.2** Commonly used anti-emetic drugs, dose and route of administration

Type of drug	Example	Usual dose
Dopamine antagonists	Metoclopramide	10 mg orally or IV
5-hydroxytryptamine antagonists	Ondansetron	4–8 mg orally or IV
Antihistamines	Cyclizine	50 mg IM or IV
Anticholinergics	Hyoscine	1 mg transdermal patch

- *steroids*: to patients on long-term treatment or who have received them within the past 3 months;
- *antibiotics*: to patients with prosthetic or diseased heart valves, or undergoing joint replacement;
- *anticoagulants*: as prophylaxis against deep venous thrombosis;
- *transdermal glyceryl trinitrate (GTN)*: as patches in patients with ischaemic heart disease to reduce the risk of coronary ischaemia;
- *eutectic mixture of local anaesthetics (EMLA)*: a topically applied local anaesthetic cream to reduce the pain of inserting an IV cannula.

The majority of the patient's own regular medications should be taken as normal, unless instructed otherwise by the anaesthetist.

### Preoperative starvation

Traditionally, patients were starved of both food and fluids for prolonged periods preoperatively, but it is now increasingly recognized that, apart from certain groups with an increased risk of aspiration, this is not necessary.

### Guidelines for normal healthy patients undergoing elective surgery

- No solid food for 6 h preoperatively.
- Clear fluids can be taken up to 2 h preoperatively; these include water, black tea or coffee, pulpless fruit juice.
- Milk is not allowed as it flocculates in gastric acid and the fat delays gastric emptying.
- Chewing gum does not increase gastric volume and is best treated as for clear fluids.
- Normal medications can be taken with a small volume of water.
- The use of opiates or anticholinergics as premedicants has little effect on gastric volume.

### Patients at increased risk of aspiration

- Delayed gastric emptying:
  - recent trauma;
  - ileus;
  - pregnancy;
  - alcohol, opiates, anticholinergics;
  - autonomic neuropathy (diabetes mellitus).
- Gastro-oesophageal reflux:
  - symptoms of, or known hiatus hernia;
  - obesity;
  - pregnancy, children;
  - position for surgery (steep head-down).

These patients will benefit from the methods described above to reduce gastric volume and increase the pH of the contents. In the trauma patient the time from last meal to injury may be a better indicator of the gastric volume.

### Managing the airway

Maintenance of a patent airway is an essential prerequisite for the safe and successful conduct of anaesthesia. However, it is a skill that should be acquired by all doctors, as during resuscitation patients often have an obstructed airway either as the cause or result of their loss of consciousness. The descriptions of airway management techniques that follow are intended to *supplement* practice either on a manikin or, preferably, on an anaesthetized patient under the direction of a skilled anaesthetist.

### Basic techniques

Anaesthesia frequently results in loss of the airway, and this is most easily restored by a combination of the head tilt and a jaw thrust (see page 100). When holding a facemask in position with the index finger and thumb, the jaw thrust is achieved by lifting the angle of the mandible with the remaining fingers of one or both hands. The overall effect desired is that the patient's mandible is 'lifted' into the mask rather than that the mask is being pushed into the face (Fig. 2.1).



Figure 2.1 Mask being held on a patient's face.

### Facemasks

- A commonly used type in adults is the BOC anatomical facemask (Fig. 2.1), designed to fit the contours of the face with the minimum of pressure.
- Leakage of anaesthetic gases is minimized by an air-filled cuff around the edge.
- Masks are made in a variety of sizes, and the smallest one that provides a good seal should be used.
- Some masks have a transparent body allowing identification of vomit, making them popular for resuscitation.
- All masks must be disinfected between each patient use. Alternatively single use masks are available.

### Simple adjuncts

The oropharyngeal (Guedel) airway, and to a lesser extent the nasopharyngeal airway, are used in conjunction with the techniques described above to help maintain the airway after the induction of anaesthesia.

### Oropharyngeal airway

- Curved plastic tubes, flattened in cross-section and flanged at the oral end. They lie over the tongue, preventing it from falling back into the pharynx.
- Available in a variety of sizes suitable for all patients, from neonates to large adults. The commonest sizes are 2–4, for small to large adults, respectively.
- An estimate of the size required is given by comparing the airway length with the vertical distance between the patient's incisor teeth and the angle of the jaw.
- Initially inserted 'upside down' as far as the back of the hard palate (Fig. 2.2a), rotated 180° (Fig. 2.2b) and fully inserted until the flange lies in front of the teeth, or gums in an edentulous patient (Fig. 2.2c,d).

### Nasopharyngeal airway

- Round, malleable plastic tubes, bevelled at the pharyngeal end and flanged at the nasal end.
- Sized on their internal diameter in millimetres, length increasing with diameter. The common sizes in adults are 6–8 mm, for small to large adults, respectively.
- A guide to the correct size is made by comparing the diameter to the external nares.
- Prior to insertion, the patency of the nostril (usually the right) should be checked and the airway lubricated.
- The airway is inserted along the floor of the nose, with the bevel facing medially to avoid catching the turbinates (Fig. 2.3).
- A safety pin may be inserted through the flange to prevent inhalation of the airway.
- If obstruction is encountered, force should not be used as severe bleeding may be provoked. Instead, the other nostril can be tried.

### Problems with airways

Snoring, indrawing of the supraclavicular, suprasternal and intercostal spaces, use of the accessory muscles or paradoxical respiratory move-

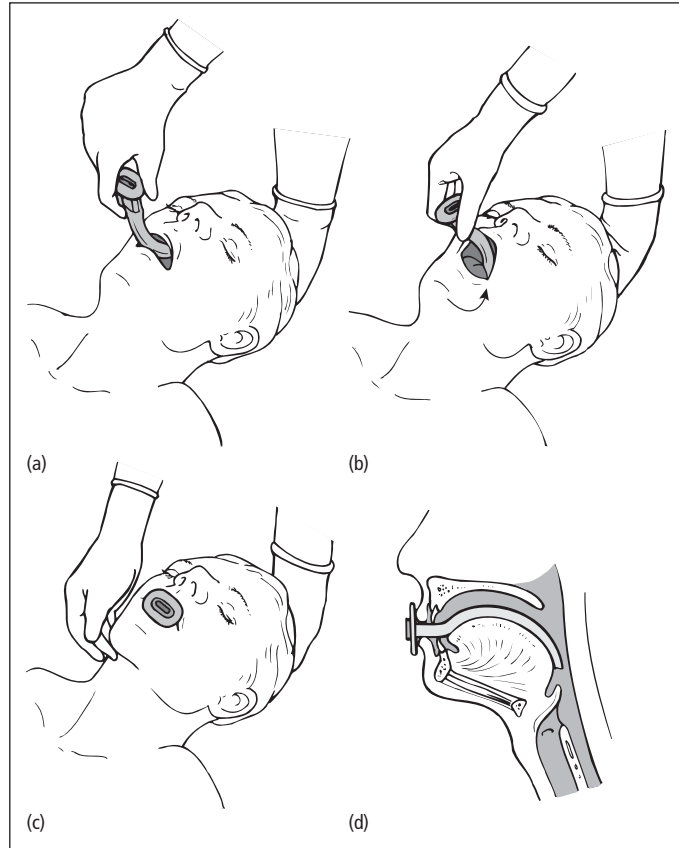

**Figure 2.2** The sequence of inserting an oropharyngeal airway.

ment (see-saw respiration) suggest that the above methods are failing to maintain a patent airway.

Other problems with these techniques include:

- inability to maintain a good seal between the patient's face and the mask, particularly in those without teeth;
- fatigue, when holding the mask for prolonged periods;
- the risk of aspiration, due to the loss of upper airway reflexes;
- the anaesthetist not being free to deal with any other problems that may arise.

The laryngeal mask airway or tracheal intubation may be used to overcome these problems.

### The laryngeal mask airway (LMA)

Originally designed for use in spontaneously breathing patients, it consists of a 'mask' that sits over the laryngeal opening, attached to which is a tube that protrudes from the mouth and connects directly to the anaesthetic breathing system. On the perimeter of the mask is an inflatable cuff that creates a seal and helps to stabilize it (Fig. 2.4a). The LMA is produced in a variety of sizes suitable for all patients, from neonates to adults, with sizes 3, 4 and 5 being the most commonly used in female and male adults. Patients can be ventilated via the LMA provided that high inflation pressures are avoided, otherwise leakage occurs past the cuff. This reduces ventilation and may cause gastric inflation. The LMA is reusable, provided that it is

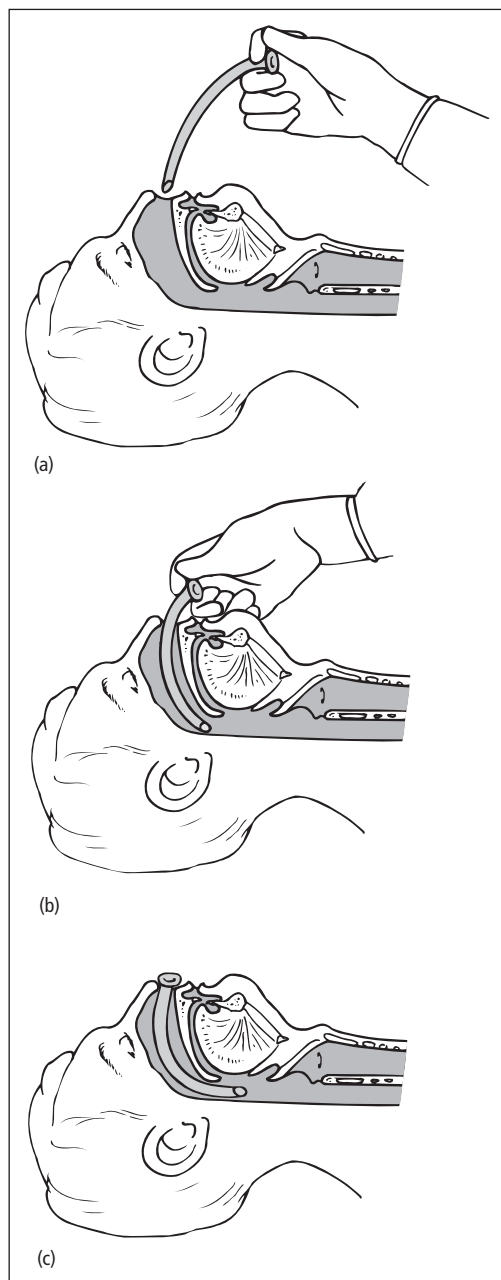

Figure 2.3 Insertion of a nasopharyngeal airway.

sterilized between each patient. There are now four additional types of LMAs available:

- A version with a reinforced tube to prevent kinking (Fig. 2.4b).
- The Proseal LMA (Fig. 2.4c): this has an additional posterior cuff to improve the seal around the larynx and reduce leak when the patient is ventilated. It also has a secondary tube to allow drainage of gastric contents.
- The intubating LMA (Fig. 2.4d): as the name suggests this device is used as a conduit to perform tracheal intubation without the need for laryngoscopy (see Tracheal intubation, below).
- A disposable version of the original for single use, for example in infected cases.

The use of the laryngeal mask overcomes some of the problems of the previous techniques:

- It is not affected by the shape of the patient's face or the absence of teeth.
- The anaesthetist is not required to hold it in position, avoiding fatigue and allowing any other problems to be dealt with.
- It *significantly reduces* the risk of aspiration of regurgitated gastric contents, but does not eliminate it completely.

Its use is *relatively contraindicated* where there is an increased risk of regurgitation, for example in emergency cases, pregnancy and patients with a hiatus hernia. The LMA has proved to be a valuable aid in those patients who are difficult to intubate, as it can usually be inserted to facilitate oxygenation while additional help or equipment is obtained (see below).

### Technique for insertion of the standard LMA

The patient's reflexes must be suppressed to a level similar to that required for the insertion of an oropharyngeal airway to prevent coughing or laryngospasm.

- The cuff is deflated (Fig. 2.5a) and the mask lightly lubricated.
- A head tilt is performed, the patient's mouth opened fully and the tip of the mask inserted along the hard palate with the open side facing but not touching the tongue (Fig. 2.5b).

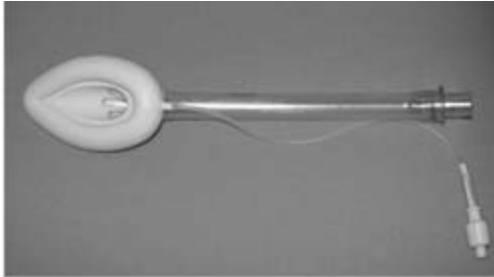

(a)

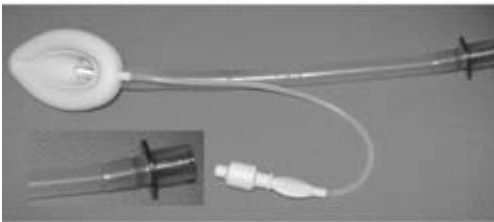

(b)

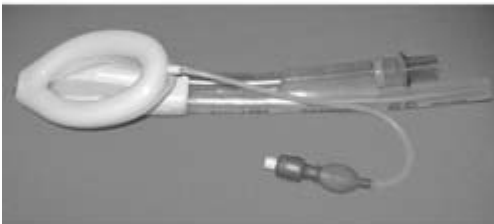

(c)

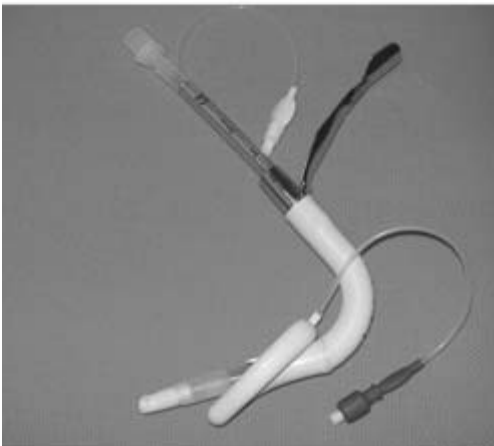

(d)

**Figure 2.4** From the top down: (a) standard laryngeal mask airway (LMA); (b) reinforced LMA with close-up of reinforcement; (c) Proseal LMA; (d) intubating LMA with tracheal tube passing through the mask.

- The mask is further inserted, using the index finger to provide support for the tube (Fig. 2.5c). Eventually, resistance will be felt at the point where the tip of the mask lies at the upper oesophageal sphincter (Fig. 2.5d).
- The cuff is now fully inflated using an air-filled syringe attached to the valve at the end of the pilot tube (Fig. 2.5e).
- The laryngeal mask is secured either by a length of bandage or adhesive strapping attached to the protruding tube.
- A 'bite block' may be inserted to reduce the risk of damage to the LMA at recovery.

### Tracheal intubation

This is the best method of providing and securing a clear airway in patients during anaesthesia and resuscitation, but success requires abolition of the laryngeal reflexes. During anaesthesia, this is usually achieved by the administration of a muscle relaxant (see below). Deep inhalational anaesthesia or local anaesthesia of the larynx can also be used, but these are usually reserved for patients where difficulty with intubation is anticipated, for example in the presence of airway tumours or immobility of the cervical spine.

### Common indications for tracheal intubation

- Where muscle relaxants are used to facilitate surgery (e.g. abdominal and thoracic surgery), thereby necessitating the use of mechanical ventilation.
- In patients with a full stomach, to protect against aspiration.
- Where the position of the patient would make airway maintenance difficult, for example the lateral or prone position.
- Where there is competition between surgeon and anaesthetist for the airway (e.g. operations on the head and neck).
- Where controlled ventilation is utilized to improve surgical access (e.g. neurosurgery).
- In those patients in whom the airway cannot be satisfactorily maintained by any other technique.
- During cardiopulmonary resuscitation.

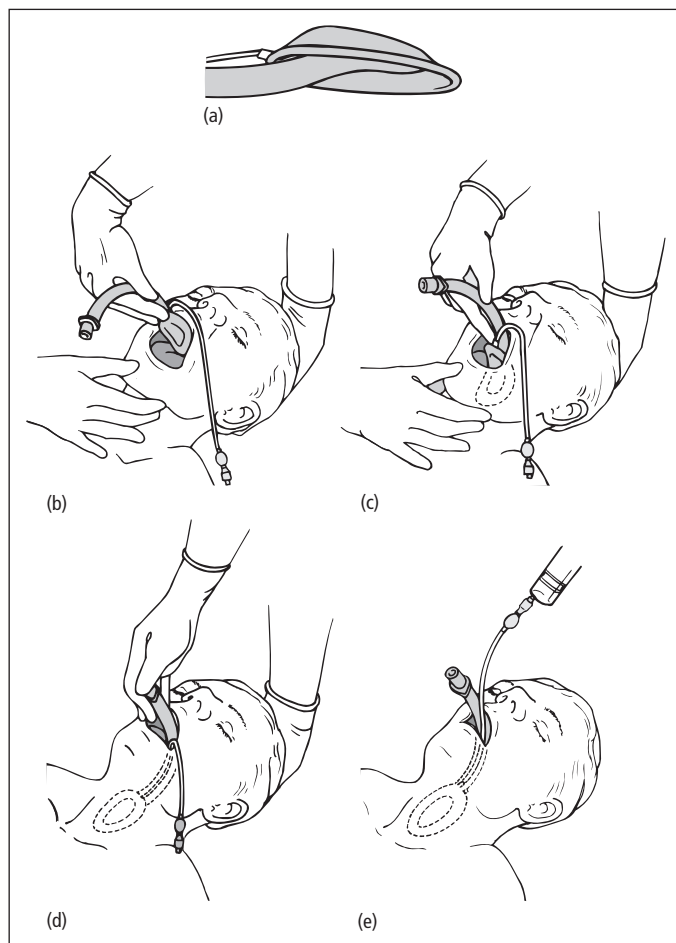

**Figure 2.5** (a-e) Sequence of events in the insertion of a laryngeal mask airway (LMA).

### Equipment for tracheal intubation

The equipment used will be determined by the circumstances and by the preferences of the individual anaesthetist. The following is a list of the basic needs for *adult oral* intubation.

- *Laryngoscope*: with a curved (Macintosh) blade and functioning light.
- *Tracheal tubes (cuffed)*: in a variety of sizes. The internal diameter is expressed in millimetres and the length in centimetres. They may be lightly lubricated.
  - For males: 8.0–9.0mm internal diameter, 22–24 cm length.
  - For females: 7.5–8.5 mm internal diameter, 20–22 cm length.

- *Syringe*: to inflate the cuff once the tube is in place.
- *Catheter mount*: or 'elbow' to connect the tube to the anaesthetic system or ventilator tubing.
- *Suction*: switched on and immediately to hand in case the patient vomits or regurgitates.
- *Stethoscope*: to check correct placement of the tube by listening for breath sounds during ventilation.
- *Extras*: a semi-rigid introducer to help mould the tube to a particular shape; Magill's forceps, designed to reach into the pharynx to remove debris or direct the tip of a tube; bandage or tape to secure the tube.



## Tracheal tubes

Mostly manufactured from plastic (PVC), and for single use to eliminate cross-infection (Fig. 2.6B). They are available in 0.5 mm diameter intervals, and long enough to be used orally or nasally. A standard 15 mm connector is provided to allow connection to the breathing system.

In adult anaesthesia, a tracheal tube with an inflatable cuff is used to prevent leakage of anaesthetic gases back past the tube when positive pressure ventilation is used. This also helps prevent aspiration of any foreign material into the lungs. The cuff is inflated by injecting air via a pilot tube, at the distal end of which is a one-way valve to prevent deflation and a small 'balloon' to indicate when the cuff is inflated. A wide variety of specialized tubes have been developed, examples of which are shown in Fig. 2.6.

- *Reinforced tubes* are used to prevent kinking and subsequent obstruction as a result of the positioning of the patient's head (Fig. 2.6C).
- *Preformed tubes* are used during surgery on the head and neck, and are designed to take the connections away from the surgical field (Fig. 2.6D).

- *Double lumen tubes* are effectively two tubes welded together side-by-side, with one tube extending distally beyond the other. They are used during thoracic surgery, and allow one lung to be deflated whilst ventilation is maintained via the bronchial portion in the opposite lung (Fig. 2.6E).
- *Uncuffed tubes* are used in children up to approximately 10 years of age as the narrowing in the subglottic region provides a natural seal (Fig. 2.6A).

## The technique of oral intubation

### Preoxygenation

All patients who are to be intubated are asked to breathe 100% oxygen via a close-fitting facemask for 2–3 mins ('preoxygenation'). This provides a reservoir of oxygen in the patient's lungs, reducing the risk of hypoxia if difficulty is encountered with intubation. Once this has been accomplished, the appropriate drugs will be administered to render the patient unconscious and abolish laryngeal reflexes.

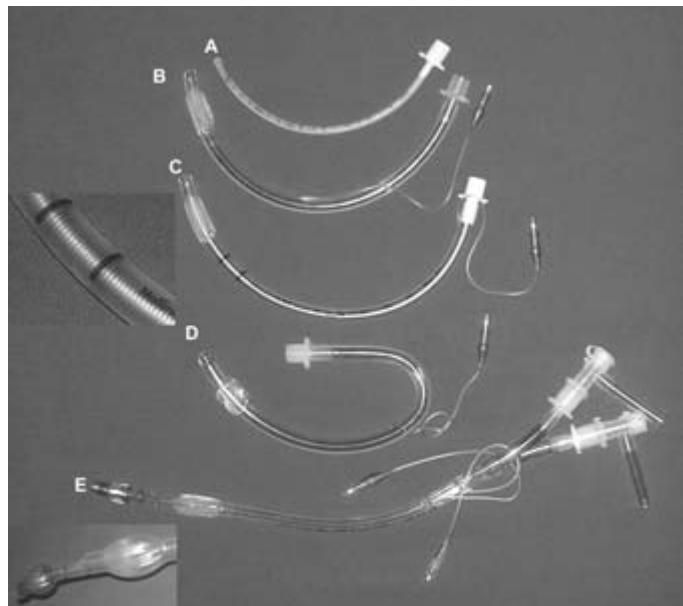

**Figure 2.6** Tracheal tubes: (A) paediatric (uncuffed); (B) adult (cuffed); (C) reinforced (close-up showing reinforcement); (D) preformed (RAE); and (E) double lumen (close-up showing tracheal and bronchial cuffs).

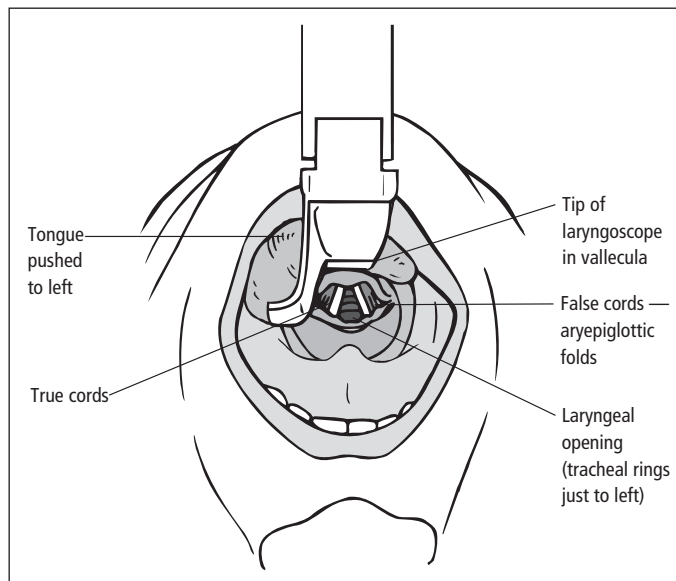

**Figure 2.7** A view of the larynx at laryngoscopy.

## Positioning

The patient's head is placed on a small pillow with the neck flexed and the head extended at the atlanto-occipital joint, the 'sniffing the morning air' position. The patient's mouth is fully opened using the index finger and thumb of the *right* hand in a scissor action.

## Laryngoscopy

The laryngoscope is held in the *left* hand and the blade introduced into the mouth along the right-hand side of the tongue, displacing it to the left. The blade is advanced until the tip lies in the gap between the base of the tongue and the epiglottis, the vallecula. Force is then applied *in the direction in which the handle of the laryngoscope is pointing*. The effort comes from the upper arm not the wrist, to lift the tongue and epiglottis to expose the larynx, seen as a triangular opening with the apex anteriorly and the whitish coloured true cords laterally (Fig. 2.7).

## Intubation

The tracheal tube is introduced into the right side of the mouth, advanced and *seen to pass through the cords* until the cuff lies just below the cords. The tube is then held firmly and the laryngoscope is carefully removed, and the cuff is inflated sufficiently to prevent any leak during ventilation. Finally the position of the tube is confirmed and secured in place.

For nasotracheal intubation a well-lubricated tube is introduced, usually via the right nostril along the floor of the nose with the bevel pointing medially to avoid damage to the turbinates. It is advanced into the oropharynx, where it is usually visualized using a laryngoscope in the manner described above. It can then either be advanced directly into the larynx by pushing on the proximal end, or the tip picked up with Magill's forceps (which are designed not to impair the view of the larynx) and directed into the larynx. The procedure then continues as for oral intubation.

## The intubating LMA (ILM)

This is a modification of the LMA in which the mask part is almost unchanged, but a shorter,

wider metal tube with a 90° bend in it replaces the flexible tube (Fig. 2.4d). A handle is attached to the tube. It is inserted by holding the handle rather than using one's index finger as a guide, and sits opposite the laryngeal opening. A specially designed reinforced, cuffed, tracheal tube can then be inserted, and, due to the shape and position of the ILM, will almost always pass into the trachea. Once it has been confirmed that the tube lies in the trachea, the ILM can either be left in place or removed. This device has proved to be very popular in cases where direct laryngoscopy does not give a good view of the larynx and tracheal intubation fails.

### Confirming the position of the tracheal tube

This can be achieved using a number of techniques:

- *Measuring the carbon dioxide in expired gas (capnography)*: less than 0.2% indicates oesophageal intubation.
- *Oesophageal detector*: a 50 mL syringe is attached to the tracheal tube and the plunger rapidly withdrawn. If the tracheal tube is in the oesophagus, resistance is felt and air cannot be aspirated; if it is in the trachea, air is easily aspirated.
- *Direct visualization*: of the tracheal tube passing between the vocal cords.
- *Fogging*: on clear plastic tube connectors during expiration.
- *Less reliable signs are*:
  - diminished breath sounds on auscultation;
  - decreased chest movement on ventilation;
  - gurgling sounds over the epigastrium and 'burping' sounds as gas escapes;
  - a decrease in oxygen saturation detected by pulse oximetry. This occurs late, particularly if the patient has been preoxygenated.

### Complications of tracheal intubation

The following complications are the more common ones, not an attempt to cover all occurrences.

### Hypoxia

Due to:

- *Unrecognized oesophageal intubation* If there is any doubt about the position of the tube it should be removed and the patient ventilated via a facemask.
- *Failed intubation and inability to ventilate the patient* This is usually a result of abnormal anatomy or airway pathology. Many cases are predictable at the preoperative assessment (see page 6).
- *Failed ventilation after intubation* Possible causes include the tube becoming kinked, disconnected, or inserted too far and passing into one main bronchus; severe bronchospasm and tension pneumothorax.
- *Aspiration* Regurgitated gastric contents can cause blockage of the airways directly, or secondary to laryngeal spasm and bronchospasm. Cricoid pressure can be used to reduce the risk of regurgitation prior to intubation (see below).

### Trauma

- *Direct* During laryngoscopy and insertion of the tube, damage to lips, teeth, tongue, pharynx, larynx, trachea, and nose and nasopharynx during nasal intubation; causing soft tissue swelling or bleeding.
- *Indirect* To the recurrent laryngeal nerves, and the cervical spine and cord, particularly where there is pre-existing degenerative disease or trauma.

### Reflex activity

- *Hypertension and arrhythmias* Occurs in response to laryngoscopy and intubation. May jeopardize patients with coronary artery disease. In patients at risk, specific action is taken to attenuate the response; for example pretreatment with beta blockers or potent analgesics (fentanyl, remifentanyl).
- *Vomiting* This may be stimulated when laryngoscopy is attempted in patients who are inadequately anaesthetized. It is more frequent when there is material in the stomach; for example in emergencies when the patient is not starved, in

patients with intestinal obstruction, or when gastric emptying is delayed, as after opiate analgesics or following trauma.

- *Laryngeal spasm* Reflex adduction of the vocal cords as a result of stimulation of the epiglottis or larynx.

### Difficult intubation

Occasionally, intubation of the trachea is made difficult because of an inability to visualize the larynx. This may have been predicted at the preoperative assessment or may be unexpected. A variety of techniques have been described to help solve this problem and include the following:

- Manipulation of the thyroid cartilage by backwards and upwards pressure by an assistant to try and bring the larynx or its posterior aspect into view.
- At laryngoscopy, a gum elastic bougie, 60cm long, is inserted blindly into the trachea, over which the tracheal tube is 'railroaded' into place.
- A fiberoptic bronchoscope is introduced into the trachea via the mouth or nose, and is used as a guide over which a tube can be passed into the trachea. This technique has the advantage that it can be used in either anaesthetized or awake patients.
- An LMA or ILM can be inserted and used as a conduit to pass a tracheal tube directly or via a fiberoptic scope.

### Cricoid pressure (Sellick's manoeuvre)

Regurgitation and aspiration of gastric contents are life-threatening complications of anaesthesia and every effort must be made to minimize the risk. Preoperatively, patients are starved to reduce gastric volume and drugs may be given to increase pH. At induction of anaesthesia, cricoid pressure provides a physical barrier to regurgitation. As the cricoid cartilage is the only complete ring of cartilage in the larynx, pressure on it, anteroposteriorly, forces the whole ring posteriorly, compressing the oesophagus against the body of the sixth cervical vertebra, thereby preventing regurgitation. An assistant, using the thumb and index finger, applies pressure whilst the other hand is behind the patient's neck to stabilize it (Fig. 2.8). Pressure is applied as the patient loses consciousness and maintained until the tube has been inserted, the cuff inflated and correct position confirmed. It should be maintained even if the patient starts to actively vomit, as the risk of aspiration is greater than the theoretical risk of oesophageal rupture. If vomiting does occur, the patient should be turned onto his or her side to minimize aspiration.

### Can't intubate, can't ventilate

In most patients who are difficult to intubate, a patent airway and ventilation can be maintained



**Figure 2.8** Sellick's manoeuvre. Note the position of the thyroid cartilage marked on the patient's neck.

using one or more of the techniques described above. Rarely, a patient may be both difficult to intubate and ventilate. This is a life-threatening emergency and may require the anaesthetist to resort to one of the emergency techniques described below.

### Emergency airway techniques

These must only be used when all other techniques have failed to maintain oxygenation.

- *Needle cricothyroidotomy* The cricothyroid membrane is identified and punctured using a large bore cannula (12–14 gauge) attached to a syringe. Aspiration of air confirms that the tip of the cannula lies within the trachea. The cannula is then angled to about 45° caudally and advanced off the needle into the trachea (Fig. 2.9). A high-flow oxygen supply is then attached to the cannula and insufflated for 1 s, followed by a 4 s rest. Expiration occurs via the upper airway as normal. This technique oxygenates the patient but only results in minimal carbon dioxide elimination, and is therefore limited to about 30 mins use while a definitive airway is created.
- *Surgical cricothyroidotomy* This involves making an incision through the cricothyroid membrane to allow the introduction of a 5.0–6.0 mm diameter tracheostomy tube or tracheal tube (Fig. 2.10). It is more difficult to perform, and results in significantly more bleeding than the above. However, once a tube has been inserted the patient can be ventilated, ensuring oxygenation, elimination of carbon dioxide and suction of the airway to remove any blood or debris.

### Drugs used during general anaesthesia

Anaesthetists have to be familiar with a wide range of drugs that, unlike in most other branches of medicine, are almost always given parenterally: either intravenously or via inhalation. In addition to their effects on the central nervous system (CNS), most drugs have undesirable actions on many other body systems, of which the anaesthetist must be fully aware.

### Intravenous induction of anaesthesia

This is most frequently achieved in adults by the IV injection of a drug. Consciousness is lost rapidly as the concentration of the drug in the brain rises very quickly. The drug is then redistributed to other tissues and the plasma concentration falls; this is followed by a fall in brain concentration and the patient recovers consciousness. Despite a short duration of action, complete elimination, usually by hepatic metabolism, may take considerably longer and lead to accumulation. Consequently, most drugs are not given repeatedly to maintain anaesthesia. Currently, the only exception to this is propofol (see below). Whichever drug is used, the dose required to induce anaesthesia will be dramatically reduced in those patients who are elderly, frail, have compromise of their cardiovascular system or are hypovolaemic. A synopsis of the drugs commonly used is given in Table 2.3.

### Inhalational induction of anaesthesia

Breathing an inhalational anaesthetic in oxygen or in a mixture of oxygen and nitrous oxide can be used to induce anaesthesia. As the concentration of the anaesthetic in the brain increases slowly, unconsciousness occurs but more slowly than with an IV drug. Adequacy ('depth') of anaesthesia is assessed (and overdose avoided) using clinical signs or 'stages of anaesthesia'; the original description was based on using ether, but the main features can still be seen using modern drugs. The signs are modified by the concurrent administration of opiate or anticholinergic drugs. Currently, sevoflurane is the most popular anaesthetic used for this technique. Inhalation induction of anaesthesia is used when IV induction is not practical, for example in:

- a patient with a lack of suitable veins;
- an uncooperative child;
- patients with a needle phobia;
- patients with airway compromise, in which an IV drug may cause apnoea, and ventilation and oxygenation become impossible, with catastrophic results.

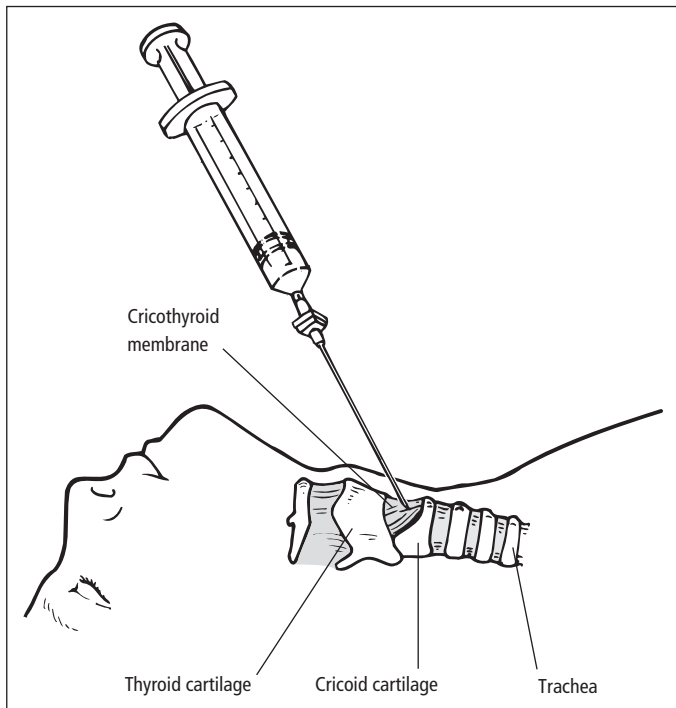

(a)

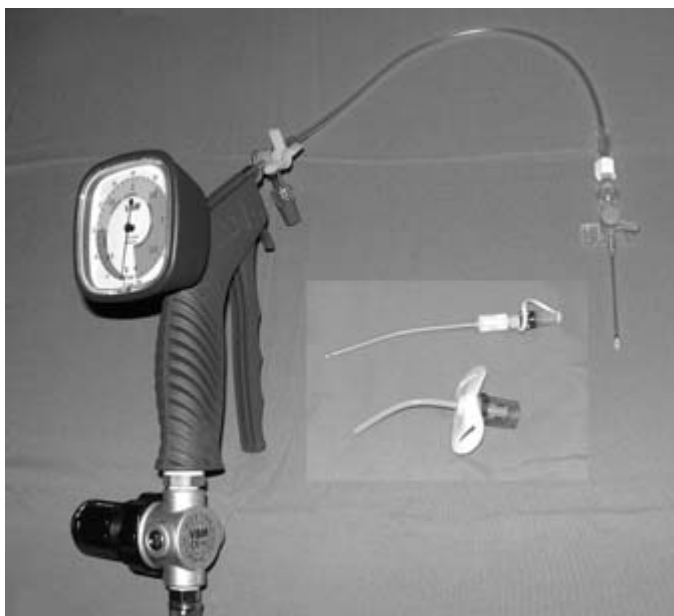

(b)

**Figure 2.9** (a) Needle cricothyroidotomy. (b) Photograph of oxygen delivery system (Manujet) attached to an intravenous cannula. The pressure of oxygen delivered is controlled by the black knob and displayed on the dial. *Inset*; preformed cannula and stylet for use as an alternative to an IV cannula for cricothyroid puncture, with integral wings to aid securing of the device.

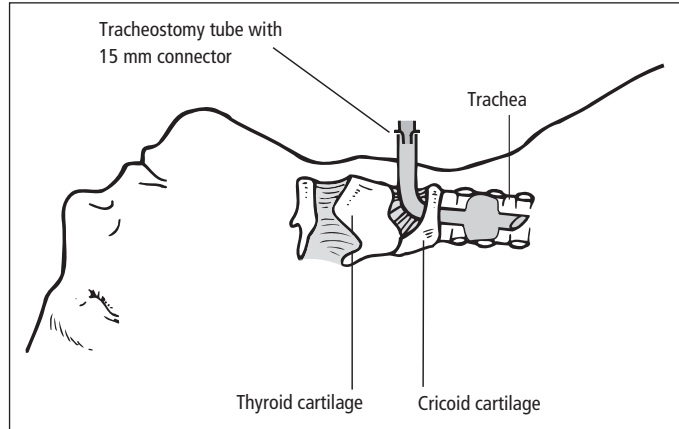

**Figure 2.10** Surgical cricothyroidotomy with insertion of small-diameter tracheostomy tube.

## The stages of anaesthesia

### First stage

This lasts until consciousness is lost. The pupils will be normal in size and reactive, muscle tone is normal and breathing uses intercostal muscles and the diaphragm.

### Second stage

In this period there may be breath-holding, struggling and coughing. It is often referred to as the stage of excitation. The pupils will be dilated and there is loss of the eyelash reflex.

### Third stage

This is the stage of surgical anaesthesia. There is reduction in respiratory activity, with progressive intercostal paralysis. Muscle tone is also reduced and laryngeal reflexes are lost. The pupils start by being slightly constricted and gradually dilate. This stage ends with diaphragmatic paralysis.

### Fourth stage

This constitutes an anaesthetic catastrophe, with apnoea, loss of all reflex activity and fixed dilated pupils.

As well as the above, the anaesthetic will have effects on all of the other body systems, which will need appropriate monitoring.

## Maintenance of anaesthesia

This can be achieved either by using one of a variety of inhalational anaesthetics in oxygen with or without nitrous oxide, or by an intravenous infusion of a drug, most commonly propofol.

### Inhalational anaesthesia

Inhalational anaesthetics are a group of halogenated hydrocarbons with relatively low boiling points. A 'vaporizer' is used to produce an accurate concentration in the inspired gas mixture. Nitrous oxide is the only other drug in this category. The inspired concentration of all of these compounds is expressed as the percentage by volume. A synopsis of the drugs used is given in Table 2.4.

There are two concepts that will help in understanding the use of inhalational anaesthetics: minimum alveolar concentration and solubility.

#### Minimum alveolar concentration

To compare potencies and side-effects of the inhalational anaesthetics, rather than simply comparing a fixed inspired concentration, the concept of *minimum alveolar concentration* (MAC) is used. This is the concentration required to prevent

Table 2.3 Intravenous drugs used for the induction of anaesthesia and their effects

Drug	Induction dose (mg/kg)	Speed of induction (s)	Duration of action (mins)	Effects on CVS	Effects on RS	Effects on CNS	Other side-effects	Comments
Propofol	1.5–2.5	30–45	4–7	Hypotension, worse if hypovolaemic or cardiac disease	Apnoea up to 60s, depression of ventilation	Decreases CBF and ICP	Pain on injection, involuntary movement, hiccoughs	Non-cumulative, repeated injections or infusion used to maintain anaesthesia (see TIVA)
Etomidate	0.2–0.3	30–40	3–6	Relatively less cardiovascular depression	Depression of ventilation	Decreases CBF and ICP, anticonvulsant	Pain on injection, involuntary movement, hiccoughs	Emulsion available, less painful. No histamine release, non-cumulative, but suppresses steroid synthesis
Thiopentone	2–6	20–30	9–10	Dose dependent hypotension, worse if hypovolaemic or cardiac disease	Apnoea, depression of ventilation	Decreases CBF and ICP, anticonvulsant	Rare but severe adverse reactions	Patients may 'taste' garlic or onions! Cumulative, delayed recovery after repeat doses
Ketamine	1–2	50–70	10–12	Minimal in fit patients, better tolerated if cardiovascular compromise	Minimal depression of ventilation, laryngeal reflexes better preserved, bronchodilation	CBF maintained, profound analgesia	Vivid hallucinations	Subanaesthetic doses cause analgesia. Can be used as sole anaesthetic drug in adverse circumstances, e.g. prehospital
Midazolam	0.1–0.3	40–70	10–15	Dose dependent hypotension, worse if hypovolaemic or cardiac disease	Depression of ventilation, worse in elderly	Mildly anticonvulsant		Causes amnesia

CVS: cardiovascular system; RS: respiratory system; CNS: central nervous system; CBF: cerebral blood flow; ICP: intracranial pressure; TIVA: total intravenous anaesthesia.



**Table 2.4** Inhalational anaesthetic drugs and their effects

Compound	Potency	Solubility	Effect on CVS	Effect on RS	Effect on CNS	Comments
Sevoflurane	Low; 6–7% for induction, 2–3% for maintenance	Low; rapid changes of depth	↓ BP, vasodilatation	Depresses ventilation	Minimal effect on CBF at clinical concentration	Popular for inhalation induction
Desflurane	Low; 6–9% for maintenance	Low; rapid changes of depth	↓ BP, ↑ HR	Depresses ventilation	Minimal effect on CBF at clinical concentration	Pungent, boils at 23°C
Isoflurane	Medium; 5% for induction, 1–1.5% for maintenance	Medium	↓ BP, ↑ HR, vasodilatation	Depresses ventilation	Slight ↑ CBF and ICP	Pungency limits use for induction
Haloethane	High; 3–4% for induction, 0.5–1% for maintenance	High	↓ BP, vasodilatation, myocardial depression, arrhythmias common	Depresses ventilation	↑↑ CBF, ↑ ICP	May cause hepatitis on repeat exposure
Enflurane	Medium; 1.5–2% for maintenance	Medium	↓ BP	Depresses ventilation	↑ CBF, ↑ EEG activity	Pungency limits use for induction

CVS: cardiovascular system; RS: respiratory system; CNS: central nervous system; BP: blood pressure; HR: heart rate; CBF: cerebral blood flow; ICP: intracranial pressure; EEG: electroencephalograph.

**Table 2.5** MAC values for inhalational anaesthetics

	Sevoflurane (%)	Desflurane (%)	Isoflurane (%)	Halothane (%)	Enflurane (%)
In 100% oxygen	2.2	6.0	1.3	0.75	1.6
In 70% nitrous oxide	1.2	2.8	0.6	0.3	0.6

movement in 50% of subjects following a surgical stimulus. At 1 MAC, or multiples thereof, the anaesthetic effect will be the same and a comparison of the side-effects can be made. Compounds with a low potency (e.g. desflurane) will have a high MAC, those with a high potency (e.g. halothane) will have a low MAC.

The effects of inhalational anaesthetics are additive, therefore two values for MAC are often quoted—the value in oxygen and the value when given with a stated percentage of nitrous oxide (which has its own MAC), which will clearly be less (Table 2.5).

The value of MAC is reduced in the elderly, in those with hypotension, hypothermia, and hypothyroidism, and with concurrent use of opioids; it is increased in infants, patients with a pyrexia, and in those who are chronic drug abusers.

### Solubility

Inhalational anaesthetics exert their effect on the central nervous system. It is the partial pressure in the brain that is responsible for the anaesthetic effect and this follows closely the partial pressure in the alveoli. The rate at which the alveolar partial pressure can be changed determines the rate of change in brain partial pressure, and hence speed of induction, change in depth of, and recovery from anaesthesia.

One of the main determinants of alveolar partial pressure is how soluble the inhalational anaesthetic is in blood. Relatively *insoluble* anaesthetics (e.g. sevoflurane, desflurane) are removed slowly from the alveoli by the pulmonary blood. The alveolar (and brain) partial pressures rise quickly and anaesthesia is induced rapidly. In contrast, a *soluble* anaesthetic (e.g. halothane) is removed rapidly from the alveoli into the pulmonary blood, limiting the rate of rise of alveolar and brain partial pressure. Consequently, induction will be slower. Recovery from anaesthesia follows similar princi-

ples in reverse. Only a small amount of an insoluble drug will have to be excreted to allow brain partial pressure to fall. With a more soluble drug, a larger amount will need to be excreted, which will take proportionately longer.

Other factors that determine the speed at which the alveolar concentration rises include:

- *A high inspired concentration:* limited clinically by the degree of irritation caused.
- *Alveolar ventilation:* this is most pronounced for drugs with a high solubility. As large amounts are removed from the alveoli, increasing ventilation ensures more rapid replacement.
- *Cardiac output:* if high, results in a greater pulmonary blood flow, increasing uptake thereby lowering the alveolar partial pressure. If low, the converse occurs and the alveolar concentration rises more rapidly.

### Nitrous oxide

Nitrous oxide (N<sub>2</sub>O) is a colourless, sweet-smelling, non-irritant gas with moderate analgesic properties but low anaesthetic potency (MAC 105%). As the maximum safe concentration that can be administered without the risk of hypoxia is approximately 70%, unconsciousness or anaesthesia sufficient to allow surgery is rarely achieved. Consequently, it is usually given in conjunction with one of the other vapours. Nitrous oxide is premixed with oxygen as a 50:50 mixture called 'Entonox' which is used as an analgesic in obstetrics and by the emergency services.

### Systemic effects

- Cardiovascular depression, exacerbated in patients with pre-existing cardiac disease.
- Slight increase in the respiratory rate and a decrease in the tidal volume. Decreases the ventilatory response to carbon dioxide and hypoxia.

- Cerebral vasodilatation, increasing intracranial pressure (ICP).
- Diffuses into air-filled cavities more rapidly than nitrogen can escape, causing either a rise in pressure (e.g. in the middle ear) or an increase in volume (e.g. within the gut or an air embolus).
- May cause bone-marrow suppression by inhibiting the production of factors necessary for the synthesis of DNA. The length of exposure necessary may be as short as a few hours, and recovery usually occurs within 1 week.
- At the end of anaesthesia, rapid excretion of nitrous oxide into the alveoli dilutes any oxygen present (diffusion hypoxia). If the patient is breathing air, hypoxia can occur. This can be overcome by increasing the inspired oxygen concentration during recovery.

### Halothane hepatitis

The precise link between the use of halothane and the subsequent development of hepatitis remains unclear. The incidence is extremely low, being in the region of 1 : 10 000–20 000 halothane administrations. The clinical picture is one of jaundice, with a massive rise in plasma aminotransferases several days after the exposure to halothane, associated with severe hepatic necrosis. The mortality rate is approximately 50%. Severe liver damage is unlikely to occur after a single exposure in adults, but repeat administration at an interval of less than 3 months should be avoided, particularly in obese, middle-aged females. With the current range of alternatives this should no longer be necessary. The risk to children appears to be much less.

### Total intravenous anaesthesia

When IV drugs alone are given to induce and maintain anaesthesia, the term ‘total intravenous anaesthesia’ (TIVA) is used. For a drug to be of use in maintaining anaesthesia, it must be rapidly eliminated or metabolized to inactive substances to prevent accumulation and delayed recovery, and have no unpleasant side-effects. Currently, an infusion of propofol is the most widely used technique; ketamine is associated with an unpleasant

recovery, etomidate suppresses steroid synthesis and recovery after barbiturates is prolonged due to their accumulation.

### TIVA using propofol

With this technique, an appropriate brain concentration of propofol must be achieved and maintained to prevent awareness and any response to surgery. The simplest way is to give the usual IV induction dose, followed by repeated injections at intervals depending on the patient’s response. This method can be used for short procedures, but for maintenance over a longer period, it is more common to use a microprocessor-controlled infusion pump (e.g. ‘Diprifusor’). This is more accurate and reliable as it uses the patient’s weight and age to calculate the rate of infusion required to achieve a constant plasma (and brain) concentration. Having entered the appropriate data, on starting the pump an initial rapid infusion is given to render the patient unconscious, followed by an infusion at a slower rate to maintain anaesthesia. This is often referred to as ‘target controlled infusion’ (TCI). The infusion rate can also be adjusted manually to change the plasma concentration to take account of individual patient variation and the degree of surgical stimulation, in the same way that the concentration of a volatile anaesthetic from the vaporizer can be changed.

Propofol alone can be used to maintain anaesthesia, but the infusion rates are very high, with significant cardiovascular side-effects. It is usually combined with either IV opioids, given as repeated injections (e.g. fentanyl), or an infusion (e.g. remifentanyl). An alternative is to use a regional anaesthetic technique for analgesia. If muscle relaxation is required, neuromuscular blocking drugs are given and the patient is usually ventilated with oxygen-enriched air. Nitrous oxide can be used, but this is not strictly TIVA and some of the advantages are lost.

### Advantages of total intravenous anaesthesia

- The potential toxic effects of the inhalational anaesthetics are avoided.

- The problems associated with nitrous oxide can be avoided.
- A better quality of recovery is claimed.
- It may be beneficial in certain types of surgery, for example neurosurgery.
- Pollution is reduced.

### Disadvantages of total intravenous anaesthesia

- Secure, reliable intravenous access is required.
- Risk of awareness if intravenous infusion fails.
- Cost of electronic infusion pumps.
- May cause profound hypotension.

### Neuromuscular blocking drugs

These work by interfering with the normal action of acetylcholine at the motor end plate, blocking the receptors on the postsynaptic muscle membrane (and possibly other sites). Muscle relaxants are divided into two groups, the names of which are thought to reflect their mode of action.

### Depolarizing neuromuscular blocking drugs

#### Suxamethonium

This is the only drug of this type in regular clinical use. It comes ready-prepared (50 mg/mL, 2 mL ampoules). The dose in adults is 1.5 mg/kg IV. After injection, there is a short period of muscle fasciculation due to depolarization of the muscle membrane, followed by muscular paralysis in 40–60 s. Recovery occurs as a result of hydrolysis by plasma (pseudo-) cholinesterase, with restoration of normal neuromuscular transmission after 4–6 mins. This rapid onset makes it the drug of choice to facilitate tracheal intubation in patients likely to regurgitate and aspirate.

#### Systemic effects

- No direct effect on the cardiovascular, respiratory or central nervous systems. Bradycardia secondary to vagal stimulation is common after very large or repeated doses, necessitating pretreatment with atropine.

• A massive rise in serum potassium may provoke dysrhythmias in certain patients with:

- burns, maximal 3 weeks to 3 months after the burn;
- denervation injury, for example spinal cord trauma, maximal after 1 week;
- muscle dystrophies, for example Duchenne's;
- crush injury.

Administration of suxamethonium is associated with a number of important side-effects:

- malignant hyperpyrexia in susceptible patients (see page 98);
- increased intraocular pressure which may cause loss of vitreous in penetrating eye injuries;
- muscular pain around the limb girdles, most common 24 h after administration in young adults;
- histamine release: usually localized but may cause an anaphylactoid reaction;
- prolonged apnoea in patients with pseudo-cholinesterase deficiency.

#### Pseudocholinesterase deficiency

A variety of genes have been identified which are involved in pseudocholinesterase production. The most significant genotypes are:

- normal homozygotes: sufficient enzyme to hydrolyse suxamethonium in 4–6 mins (950 per 1000 population);
- atypical heterozygotes: slightly reduced enzyme levels; suxamethonium lasts 10–20 mins (50 per 1000);
- atypical homozygotes: marked deficiency of enzyme; members of this group are apnoeic for up to 2 h after suxamethonium (1 per 1000).

Treatment of the third group consists of ventilatory support with maintenance of anaesthesia or sedation until recovery occurs. The patient should subsequently be warned and given a card that carries details and, because of its inherited nature, the remainder of the family should be investigated.

### Non-depolarizing neuromuscular blocking drugs

These drugs compete with acetylcholine and block its access to the postsynaptic receptor sites on the

muscle but do not cause depolarization. (They may also block prejunctional receptors responsible for facilitating the release of acetylcholine.) They are sometimes referred to as competitive neuromuscular blockers. The time to maximum effect, that is when relaxation is adequate to allow tracheal intubation, is relatively slow compared with suxamethonium, generally 1.5–3 mins. A synopsis of the drugs used is given in Table 2.6.

They are used in two ways:

- following suxamethonium to maintain muscle relaxation during surgery;
- to facilitate tracheal intubation in non-urgent situations.

Although recovery of normal neuromuscular function eventually occurs spontaneously after the use of these drugs, it is often accelerated by the administration of an anticholinesterase (see below).

### Anticholinesterases

The action of all the neuromuscular blocking drugs wears off spontaneously with time, but this is not always clinically appropriate. In patients who require reversal of neuromuscular blocking drugs, an anticholinesterase is given. This inhibits the action of the enzyme acetylcholinesterase, resulting in an increase in the concentration of acetylcholine at the neuromuscular junction (nicotinic effect). The speed of recovery will depend upon the intensity of block when reversal is attempted—the more intense the block the slower the reversal. Anticholinesterases cannot be used to reverse very intense block, for example if given soon after the administration of a relaxant (no response to a ‘train-of-four’ sequence—see below).

Anticholinesterases also function at parasympathetic nerve endings (muscarinic effect), causing bradycardia, spasm of the bowel, bladder and bronchi, increased bronchial secretions, etc. Therefore they are always administered with a suitable dose of atropine or glycopyrrolate to block the unwanted muscarinic effects.

The most commonly used anticholinesterase is neostigmine:

- A fixed dose of 2.5 mg intravenously is used in adults.

- Its maximal effect is seen after approximately 5 mins and lasts for 20–30 mins.
- It is given concurrently with either atropine 1.2 mg or glycopyrrolate 0.5 mg.

### Assessment of neuromuscular blockade

This can be achieved either clinically or by using a peripheral nerve stimulator.

#### Clinical assessment

This requires a conscious, co-operative patient to perform a sustained activity and is therefore limited in its application. Tests commonly used include:

- lifting the head off the pillow for 5 s;
- a hand grip for 5 s;
- the ability to produce a vital capacity breath, >10 mL/kg.

Inability to perform these activities and/or the presence of ‘see-sawing’ or paradoxical respiration suggests a degree of residual neuromuscular block. A further dose of neostigmine and an anticholinergic may be required.

#### Peripheral nerve stimulation

This is used in anaesthetized patients, the details of which are outside the remit of this book. The following is intended as no more than a brief outline.

A peripheral nerve supplying a discrete muscle group is stimulated transcutaneously with a current of 50 mA. The resulting contractions are observed or measured. One arrangement is to stimulate the ulnar nerve at the wrist whilst monitoring the contractions (twitch) of the adductor pollicis. Although most often done by looking at or feeling the response, measuring either the force of contraction or the compound action potential is more objective.

Sequences of stimulation used include:

- four stimuli each of 0.2 s duration, at 2 Hz for 2 s, referred to as a ‘train-of-four’ (TOF);
- One stimulus at 50 Hz of 5 s duration, that is, a tetanic stimulus;

**Table 2.6** Non-depolarizing neuromuscular blocking drugs

Drug	Dose for intubation	Maintenance dose	Time to intubation	Duration of action	Systemic effects	Comments
Atracurium	0.5–0.6 mg/kg	0.15–0.2 mg/kg; 30–50 mg/h infusion	90–120s	20–25 mins	Cutaneous histamine release, ↓BP	Spontaneous degradation in plasma. Cisatracurium a single isomer, more potent
Rocuronium	0.6–0.7 mg/kg	0.15–0.2 mg/kg; 30–50 mg/h infusion	90–100s; after 1 mg/kg, 60s	20–30 mins	Minimal	Alternative to suxamethonium for RSI
Vecuronium	0.1 mg/kg	0.02–0.03 mg/kg; 6–10 mg/h infusion	90–120s	15–20 mins	Minimal, no histamine release	White powder, dissolved before use
Mivacurium	0.15–0.2 mg/kg	0.1 mg/kg	100–120s	10–15 mins	Histamine released if large dose injected rapidly	Metabolized by plasma cholinesterase. Rapid recovery, reversal often unnecessary
Pancuronium	0.1 mg/kg	0.015 mg/kg	120–150s	35–45 mins	↑BP, ↑HR	Long-acting

BP: blood pressure; HR: heart rate; RSI: rapid sequence induction.

- two groups of three tetanic bursts at 50Hz, 750ms apart.

During non-depolarizing neuromuscular blockade, there is a *progressive* decremental response to all the sequences, termed 'fade'. In the TOF, the ratio of the amplitude of the fourth twitch (T4) to the first twitch (T1) is used as an index of the degree of neuromuscular blockade. During depolarizing blockade, the response to all sequences of stimulation is reduced but consistent, that is, there is no fade.

### When is it useful to assess the degree of neuromuscular block?

- During long surgical procedures to control the timing of increments or adjust the rate of an infusion of relaxants to prevent coughing or sudden movement. This is particularly important during surgery in which a microscope is used, for example neurosurgery.
- At the end of surgery, to plan reversal of residual neuromuscular block to ensure adequate respiratory muscle function.
- To differentiate between apnoea due to prolonged action of suxamethonium, suggesting pseudocholinesterase deficiency, and residual non-depolarizing block, when both have been given.
- In recovery, to help distinguish between residual neuromuscular block and opioids overdose as a cause of inadequate ventilation postoperatively. The former will show reduced or absent response to stimulation, the latter a normal response.

### Analgesic drugs

Analgesic drugs are used as part of the anaesthetic technique to eliminate pain, reduce the autonomic response and allow lower concentrations of inhalational or intravenous drugs to be given to maintain anaesthesia.

### Opioid analgesics

This term is used to describe all drugs that have an analgesic effect mediated through opioid receptors and includes both naturally occurring and syn-

thetic compounds. The term 'opiate' is reserved for naturally occurring substances, for example morphine. There are several opioid receptors, each identified by a letter of the Greek alphabet, at which this group of drugs can have either *agonist* or *antagonist* actions. Two of the most important receptors are  $\mu$  (mu) and  $\kappa$  (kappa), and stimulation (agonist actions) of these by a pure agonist produces the classical effects of opioids: analgesia ( $\mu$ ,  $\kappa$ ), euphoria ( $\mu$ ), sedation ( $\kappa$ ), depression of ventilation ( $\mu$ ,  $\kappa$ ) and physical dependence ( $\mu$ ). The systemic effects of opioids due to both central and peripheral actions are summarized in Table 2.7.

A synopsis of the pure agonists used in anaesthesia is given in Table 2.8. Because of the potential for physical dependence, there are strict rules governing the issue and use of most opioid drugs under the Misuse of Drugs Act 1971 (see below).

Opioid analgesics can also be partial agonists or partial agonists/antagonists. There are also drugs that are pure antagonist, have no analgesic action and reverse all the central actions of a pure agonist. It is in this role that they are used clinically.

### The partial agonists and mixed agonists/antagonists

These drugs were introduced in the hope that, with only partial agonist activity at  $\mu$  receptors or mixed agonist/antagonist actions at  $\mu$  and  $\kappa$  receptors, analgesia would be achieved without the problem of depression of ventilation. Such an ideal has not yet been achieved.

### Nalbuphine (Nubaine)

This is a synthetic analgesic with antagonist actions at  $\mu$  receptors and partial agonist actions at  $\kappa$  receptors. It is similar in potency and duration of action to morphine, and exhibits a ceiling effect of analgesia. Unfortunately, being a partial antagonist, giving morphine subsequently is relatively ineffective.

### Tramadol (Zydol)

A relatively complex analgesic, a weak opioid

**Table 2.7** Central and peripheral actions of opioids

<p><b>Central nervous system</b></p> <p>Analgesia Sedation Euphoria Nausea and vomiting Pupillary constriction Depression of ventilation:</p> <ul style="list-style-type: none"> <li>• rate more than depth</li> <li>• reduced response to carbon dioxide</li> </ul> <p>Depression of vasomotor centre Addiction (not with normal clinical use)</p> <p><b>Urinary tract</b></p> <p>Increased sphincter tone and urinary retention</p>	<p><b>Respiratory system</b></p> <p>Antitussive effect Bronchospasm in susceptible patients</p> <p><b>Cardiovascular system</b></p> <p>Peripheral venodilatation Bradycardia due to vagal stimulation</p> <p><b>Skin</b></p> <p>Itching</p>	<p><b>Gastrointestinal tract</b></p> <p>Reduced peristalsis causing:</p> <ul style="list-style-type: none"> <li>• constipation</li> <li>• delayed gastric emptying</li> </ul> <p>Constriction of sphincters</p> <p><b>Endocrine system</b></p> <p>Release of ADH and catecholamines</p>
---	---	---

ADH: antidiuretic hormone.

**Table 2.8** The pure opioid agonists used in anaesthesia

Drug	Route given	Dose	Speed of onset	Duration of action (mins)	Comments
Morphine	IM	0.2–0.3 mg/kg	20–30 mins	60–120	Also given subcutaneously, rectally, epidurally, intrathecally Effective against visceral pain and pain of myocardial ischaemia. Less effective in trauma
	IV	0.1–0.15 mg/kg	5–10 mins	45–60	
Fentanyl	IV	1–3 µg/kg	2–3 mins	20–30	Short procedures, spontaneous ventilation
		5–10 µg/kg	1–2 mins	30–60	Long procedures, controlled ventilation
Alfentanil	IV	10 µg/kg	30–60 s	5–10	Short procedures. May cause profound respiratory depression
		IV infusion	0.5–2 µg/kg/min	30–60 s	Infusion dependent
Remifentanyl	IV infusion	0.1–0.3 µg/kg/min	15–30 s	Infusion dependent	Major procedures. Very rapid recovery. Profound respiratory depression. Widely used in TIVA
Pethidine	IM	1–2 mg/kg	15–20 mins	30–60	Marked nausea and vomiting. Less effect on smooth muscle

TIVA: total intravenous anaesthesia.



agonist at  $\mu$  receptors, inhibits noradrenaline uptake and release of 5-hydroxytryptamine (5-HT). When given intravenously, it is approximately one tenth as potent as morphine and roughly equivalent to pethidine, that is, the dose being 1–2 mg/kg. It is claimed to cause less respiratory depression than equivalent doses of morphine, but if this does occur it is readily reversed by naloxone. A further advantage is that it is not a controlled drug, and is therefore more easily available.

### The pure antagonist

The only one in common clinical use is naloxone.

### Naloxone (Narcan)

This has antagonist actions at all the opioid receptors, reversing all the centrally mediated effects of pure opioid agonists.

- The initial IV dose in adults is 0.1–0.4 mg, effective in less than 60 s and lasting 30–45 mins.
- It has a limited effect against opioids, with partial or mixed actions, and complete reversal may require very high (10 mg) doses.
- Following a severe overdose, either accidental or deliberate, several doses or an infusion of naloxone may be required, as its duration of action is less than most opioids.
- Naloxone will also reverse the analgesia produced by acupuncture, suggesting that this is probably mediated in part by the release of endogenous opioids.

### The regulation of opioid drugs

Some drugs have the potential for abuse and consequent physical dependence, and their use in medicine is carefully regulated. The Misuse of Drugs Act 1971 controls 'dangerous or otherwise harmful drugs', which are designated 'Controlled Drugs' and include the opioids. The Act imposes a total prohibition on the manufacture, possession and supply of these substances, in an attempt to prevent their misuse. The Misuse of Drugs Regulations 2001 permits the use of Controlled Drugs in medicine. The drugs covered by these regulations

are classified into five schedules, each with a different level of control.

*Schedule 1* Hallucinogenic drugs, including cannabis and LSD, which currently have no recognized therapeutic use.

*Schedule 2* This includes opioids, major stimulants (amphetamines and cocaine) and quinalbarbitone.

*Schedule 3* Drugs thought not as likely to be misused as those in schedule 2, and includes barbiturates, minor stimulants, buprenorphine (Temgesic) and temazepam.

*Schedule 4* This is split into two parts:

- benzodiazepines, which are recognized as having the potential for abuse;
- androgenic steroids, clenbuterol and growth hormones.

*Schedule 5* Preparations which contain very low concentrations of codeine or morphine, for example cough mixtures.

### Supply and custody of schedule 2 drugs

In the theatre complex, these drugs are supplied by the pharmacy, usually at the written request of a senior member of the nursing staff, specifying the drug and total quantity required, and signed. These drugs must be stored in a locked safe, cabinet or room, constructed and maintained to prevent unauthorized access. A record must be kept of their use in the 'Controlled Drugs Register' and must comply with the following points:

- Separate parts of the register can be used for different drugs or strengths of drugs within a single class.
- The class of drug must be recorded at the head of each page.
- Entries must be in chronological sequence.
- Entries must be made on the day of the transaction or the next day.
- Entries must be in ink or otherwise indelible.
- No cancellation, alteration or obliteration may be made.
- Corrections must be accompanied by a footnote that must be dated.
- The register must not be used for any other purpose.

- A separate register may be used for each department (i.e. theatre).
- Registers must be kept for 2 years after the last dated entry.

The specific details required with respect to supply of Controlled Drugs (i.e. for the patient) are: the date of the transaction, name of person supplied (i.e. the patient's name), licence of person to be in possession (doctor's signature), amount supplied and form in which supplied.

### Non-steroidal anti-inflammatory drugs (NSAIDs)

These drugs inhibit the cyclo-oxygenase enzymes (COX-1 and 2) and prevent the breakdown of arachidonic acid to prostaglandins. Prostaglandins mediate inflammation peripherally and also the sensation of nociception in the CNS. There is a ceiling effect to this action and a maximum recommended dose for each drug. Prostaglandins also have important constitutive roles:

- protect the integrity of the gastric mucosa;
- maintain renal blood flow, particularly during shock;
- platelet aggregation to reduce bleeding;
- bone healing.

Older NSAIDs are non-specific COX inhibitors and associated with a significant incidence of renal failure and haemorrhage—the elderly, frail or patients taking steroids are particularly vulnerable. Gastrointestinal (GI) ulceration is unusual with short-term use but the drugs may promote fluid retention and delay fracture healing. More recently, COX-2 specific NSAIDs have become available. These target only the inducible form of the enzyme at the site of inflammation. This reduces the chance of gastric ulceration or bleeding problems, but they must still be used with great caution in potential or actual renal failure. Some asthmatic patients (especially those with recurrent nasal polyps) are prone to bronchospasm precipitated by NSAIDs. Most patients with asthma do not react to NSAIDs so it is not a general contraindication.

### Ketorolac

- A non-specific COX inhibitor, with predominantly analgesic activity, given orally, IM or IV.
- The initial parenteral dose is 10 mg, subsequently 30 mg (maximum 90 mg/day), for up to 2 days.
- Effective after orthopaedic surgery, has opioid-sparing effects after abdominal surgery.
- No effect on ventilation or cardiovascular function.
- Not subject to the Misuse of Drugs Regulations.

As well as the usual contraindications to the use of NSAIDs, ketorolac should be avoided when excessive blood loss is anticipated, or when patients are receiving other NSAIDs or anticoagulants, including low-dose heparin.

### Parecoxib

This is a selective inhibitor of COX-2 and is claimed to have fewer adverse side-effects, particularly on the GI tract and platelets. Only available for parenteral use; the initial dose is 40 mg, with subsequent doses of 20–40 mg, 6–12 hourly, maximum 80 mg/day.

### Paracetamol

Not widely used during anaesthesia, but an intravenous preparation is now available (see page 83).

## The safe delivery of anaesthesia

### The delivery of gases to the operating theatre

Most hospitals use a piped medical gas and vacuum system (PMGV) to distribute oxygen, nitrous oxide, medical air and vacuum. The pipelines' outlets act as self-closing sockets, each specifically configured, coloured and labelled for one gas. Oxygen, nitrous oxide and air are delivered to the anaesthetic room at a pressure of 400 kilopascals (kPa) (4bar, 60 pounds per square inch (psi)). The gases (and vacuum) reach the anaesthetic machine via flexible reinforced hoses, colour coded throughout their length



**Figure 2.11** Wall-mounted outlets and gas-specific probes for (left to right) oxygen, nitrous oxide, air.

**Table 2.9** Medical gas cylinder colours

Gas	Colour	
	Body	Shoulder
Oxygen	Black	White
Nitrous Oxide	Blue	Blue
Entonox	Blue	Blue/white
Air	Grey	White/black
Carbon dioxide	Grey	Grey

(oxygen white, nitrous oxide blue, vacuum yellow). These attach to the wall outlet via a gas-specific probe (Fig. 2.11) and to the anaesthetic machine via a gas-specific nut and union. Cylinders, the traditional method of supplying gases to the anaesthetic machine, are now mainly used as reserves in case of pipeline failure. Cylinders are also colour coded to indicate their contents (Table 2.9).

## Oxygen

Piped oxygen is supplied from a liquid oxygen reserve, where it is stored under pressure (10–12 bar, 1200 kPa) at approximately  $-180^{\circ}\text{C}$  in a vacuum-insulated evaporator (VIE), effectively a thermos flask. Gaseous oxygen is removed from above the liquid, or at times of increased demand, by vaporizing liquid oxygen using heat from the environment. The gas is warmed to ambient air temperature en route from the VIE to the pipeline system. A reserve bank of cylinders of compressed oxygen is kept adjacent in case of failure of the main system. A smaller cylinder is attached directly to the anaesthetic machine as an emergency reserve. The pressure in a full cylinder is

12 000 kPa (120 bar, 1980 psi) and this falls in direct proportion to the cylinder contents.

## Nitrous oxide

Piped nitrous oxide is supplied from large cylinders, several of which are joined together to form a bank, attached to a common manifold. There are usually two banks, one running with all cylinders turned on (duty bank), and a reserve. In addition, there is a small emergency supply. Smaller cylinders are attached directly to the anaesthetic machine. At room temperature, nitrous oxide is a liquid within the cylinder, and while any liquid remains the pressure within the cylinder remains constant (440 kPa, 640 psi). When all the liquid has evaporated, the cylinder contains only gas and as it empties, the pressure falls to zero.

## Medical air

This is supplied either by a compressor or in cylinders. A compressor delivers air to a central reservoir, where it is dried and filtered to achieve the desired quality before distribution. Air is supplied to the operating theatre for anaesthetic use at 400 kPa, and at 700 kPa to power medical tools.

## Vacuum

The final part of the PMGV system is medical vacuum. Two pumps are connected to a system that must be capable of generating a vacuum of at least 400 mmHg below atmospheric pressure. This is delivered to the anaesthetic rooms, operating theatre and other appropriate sites. At several



**Figure 2.12** Oxygen, air and nitrous oxide flowmeters on an anaesthetic machine.

stages between the outlets and the pumps there are drains and bacterial filters to prevent contamination by aspirated fluids.

### The anaesthetic machine

Its main functions are to allow:

- the accurate delivery of varying flows of gases to an anaesthetic system;
- an accurate concentration of an anaesthetic vapour to be added to the gas stream.

In addition to these functions, many modern anaesthetic machines contain integral monitoring equipment and ventilators.

### Measurement of flow

This is achieved on most anaesthetic machines by the use of flowmeters ('rotameters'; Fig. 2.12):

- A specific, calibrated flowmeter is used for each gas.
- A needle valve controls the flow of gas through the flowmeter.
- A rotating bobbin floats in the gas stream, its upper edge indicating the rate of gas flow.
- Several flowmeters are mounted adjacent with oxygen to the left; the control for oxygen has a different knurled finish and is usually more prominent.
- Flowmeters do not regulate pressure.

### Safety features

- The oxygen and nitrous oxide controls are linked such that less than 25% oxygen cannot be delivered.
- If carbon dioxide is fitted, flow is limited to 500mL/min.
- An emergency oxygen 'flush' device can be used to deliver pure oxygen into the breathing system.
- An audible alarm to warn of oxygen failure. This discontinues the nitrous oxide supply and if the patient is breathing spontaneously air can be entrained.
- A non-return valve to minimize the effects of back-pressure on the function of flowmeters and vaporizers.
- Pressure relief valves are fitted primarily to protect the equipment, not the patient!

### The addition of anaesthetic vapours

Vapour-specific devices are used to produce an accurate concentration of each inhalational anaesthetic:

- Vaporizers produce a saturated vapour from a reservoir of liquid anaesthetic.
- The final concentration of anaesthetic is controlled by varying the proportion of gas passing into the vapour chamber.
- The vaporizers are temperature compensated (hence -tec suffix, e.g. Sevotec) to account for the loss of latent heat that causes cooling and reduces vaporization of the anaesthetic.

The resultant mixture of gases and vapour is finally delivered to a common outlet on the

anaesthetic machine. From this point, specialized breathing systems are used to transfer the gases and vapours to the patient.

### Checking the anaesthetic machine

It is the responsibility of each anaesthetist to check that the apparatus used will function in the manner expected at the beginning of each operating session. The main danger is that the anaesthetic machine appears to perform normally, but in fact is delivering a hypoxic mixture to the patient. In order to minimize the risk of this, the Association of Anaesthetists of Great Britain and Ireland (AAGBI) has published a *Checklist for Anaesthetic Machines*. Its main aim is to ensure that oxygen flows through the oxygen delivery system and is unaffected by the use of any additional gas or vapour. Most modern anaesthetic machines now have built-in oxygen analysers that monitor the inspired oxygen concentration to minimize this risk.

### Anaesthetic breathing systems

The mixture of anaesthetic gas and vapour travels from the anaesthetic machine to the patient via an anaesthetic circuit, or more correctly an anaesthetic breathing system. Delivery to the patient is via a facemask, laryngeal mask or tracheal tube (see pages 18–25). There are a number of different breathing systems (referred to as ‘Mapleson A’, B, C, D or E) plus a circle system. The details of these systems are beyond the scope of this book, but they all have a number of common features, described below. As several patients in succession may breathe through the same system, a low-resistance, disposable bacterial filter is placed at the patient end of the system, and changed between each patient to reduce the risk of cross-infection. Alternatively, disposable systems are used, and changed for each patient.

### Components of a breathing system

All systems consist of the following:

- *A connection for fresh gas input* Usually the common gas outlet on the anaesthetic machine.
- *A reservoir bag* Usually of 2L capacity to allow

the patient’s peak inspiratory demands (30–40L/min) to be met with a lower constant flow from the anaesthetic machine. Its excursion gives an indication of ventilation and allows manual ventilation of the patient. It also acts as a further safety device, being easily distended at low pressure if obstruction occurs.

- *An adjustable expiratory valve* To vent expired gas, helping to eliminate carbon dioxide. During spontaneous ventilation, resistance to opening is minimal so as not to impede expiration. Closing the valve allows manual ventilation by squeezing the reservoir bag.

An example of a commonly used system is shown in Fig. 2.13.

### The circle system

The traditional breathing systems relied on the positioning of the components and the gas flow from the anaesthetic machine to eliminate carbon dioxide in expired gas, thereby preventing rebreathing and hypercapnia. Even the most efficient system is still wasteful; a gas flow of 4–6L/min is required and the expired gas contains oxygen and anaesthetic vapour in addition to carbon dioxide. The circle system (Fig. 2.14) overcomes these inefficiencies:

- The expired gases, instead of being vented to the atmosphere, are passed through a container of soda lime (the absorber), a mixture of calcium, sodium and potassium hydroxide, to chemically remove carbon dioxide.
- Supplementary oxygen and anaesthetic vapour are added to maintain the desired concentrations, and the mixture rebreathed by the patient. Gas flows from the anaesthetic machine to achieve this can be as low as 0.5L/min. The circle system is therefore the only true ‘anaesthetic circuit’.
- The gases are warmed and humidified as they pass through the absorber (by-products of the reaction removing carbon dioxide).

There are several points to note when using a circle system.

- As the inspired gas is a mixture of expired and fresh gas, the concentration of oxygen within the circle is not known accurately. The inspired oxygen

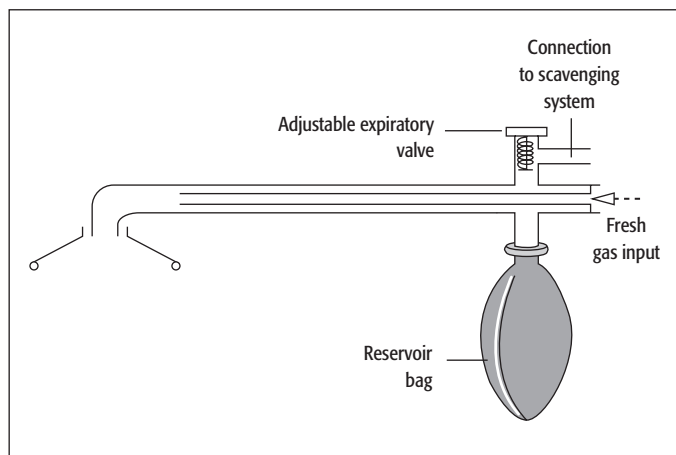

**Figure 2.13** The component parts of a breathing system and photograph of the system connected to the common gas outlet on the anaesthetic machine. Note the port on the expiratory valve (white) to allow connection to the anaesthetic gas scavenging system.

concentration must be monitored to ensure that the patient is not rendered hypoxic (see page 53).

- The inspired anaesthetic concentration must be monitored, particularly when a patient is being ventilated through a circle, to prevent awareness.
- When unable to absorb any more carbon dioxide, a change in the colour of the granules occurs as a result of the incorporation of an indicator. One of the commonly used preparations changes from pink to white.

## Mechanical ventilation

A wide variety of anaesthetic ventilators are available, each of which functions in a slightly different way. An outline of the principles of mechanical ventilation is given and the interested reader should consult Further reading at the end of the chapter.

During spontaneous ventilation, gas moves into the lungs by a negative intrathoracic pressure. This process is reversed during mechanical ventilation. A positive pressure is applied to the anaesthetic gases to overcome airway resistance and elastic

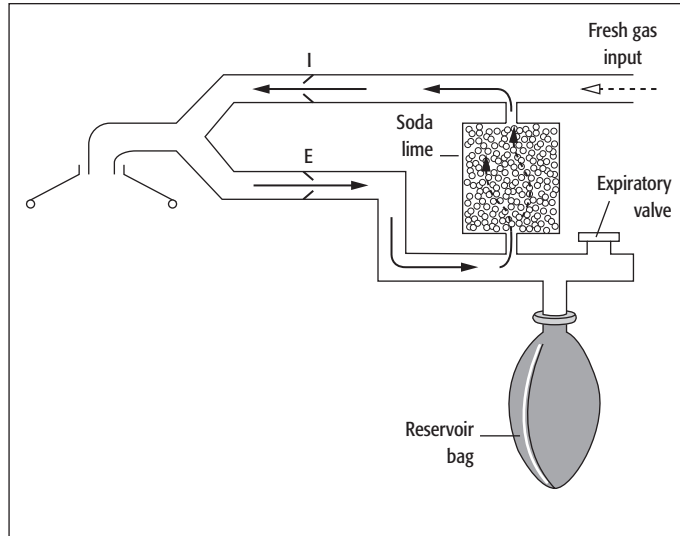

**Figure 2.14** Diagram and photograph of a circle system. The internal arrangement of the pipe-work in the system allows most of the components in the diagram to be situated on the top of the absorber. (I, inspiratory; E, expiratory one-way valves).

recoil of the chest, and flow occurs into the lungs. This technique is usually referred to as *intermittent positive pressure ventilation* (IPPV). In both spontaneous and mechanical ventilation, expiration oc-

curs by passive recoil of the lungs and chest wall. In order to generate a positive pressure, the ventilator requires a source of energy: gravity, gas pressure or electricity.



## Gravity

The Manley is a typical example of a ventilator using this operating principle. Gas from the anaesthetic machine collects within a bellows that is compressed by a weight. At a predetermined time a valve opens and the contents of the bellows are delivered to the patient (Fig. 2.15).

## Gas pressure

Gas from the anaesthetic machine collects in a bellows or bag situated in a rigid container (Fig. 2.16). The ventilator controls the delivery of a gas (usually oxygen) at high pressure into the container to compress the bellows or bag, delivering the contents to the patient. This system is often called a 'bag-in-bottle' ventilator.

## Electricity

Electrical power opens and closes valves to control the flow (and volume) of gas from a high-pressure source. Alternatively, an electric motor can power a piston within a cylinder to deliver a volume of gas to the patient (Fig. 2.17). Modern ventilators rely increasingly on complex electronics to control gas delivery and the inspiratory and expiratory timing of ventilation.

## The effects of positive pressure ventilation

- There is an increase in both the physiological dead space relative to the tidal volume and ventilation/perfusion ( $V/Q$ ) mismatch, the effect of which is to impair oxygenation. An inspired oxygen concentration of around 30% is used to compensate and prevent hypoxaemia.
- The arterial partial pressure of carbon dioxide ( $P_{aCO_2}$ ) is dependent on alveolar ventilation. Over-ventilation results in hypocapnia, causing a respiratory alkalosis. This 'shifts' the oxyhaemoglobin dissociation curve to the left, increasing the affinity of haemoglobin for oxygen. Hypocapnia will induce vasoconstriction in many organs, includ-

ing the brain and heart, reducing blood flow. Under-ventilation will lead to hypercapnia, causing a respiratory acidosis. The effects on the oxyhaemoglobin dissociation curve are the opposite of above, along with stimulation of the sympathetic nervous system causing vasodilatation, hypertension, tachycardia and arrhythmias.

- Excessive tidal volume may cause overdistension of the alveoli. In patients with pre-existing lung disease this may cause a pneumothorax, and, long term, a condition called ventilator-induced lung injury.
- The positive intrathoracic pressure reduces venous return to the heart and cardiac output.
- Both systemic and pulmonary blood flow are reduced, the latter further increasing  $V/Q$  mismatch.

## Minimizing theatre pollution

Unless special measures are taken, the atmosphere in the operating theatre will become polluted with anaesthetic gases. The breathing systems described and mechanical ventilators vent varying volumes of excess and expired gas into the atmosphere, the patient expires anaesthetic gas during recovery and there are leaks from anaesthetic apparatus. Although no conclusive evidence exists to link prolonged exposure to low concentrations of inhalational anaesthetics with any risks, it would seem sensible to minimize the degree of pollution within the operating theatre environment. This can be achieved in a number of ways:

- reduce the flow of gases, for example by use of a circle system;
- avoid use of gases, for example by use of TIVA, regional anaesthesia;
- use of air conditioning in the theatre;
- scavenging systems.

## Scavenging systems

These collect the gas vented from breathing systems and ventilators and deliver it via a pipeline system to the external atmosphere. The most widely used is an active system in which a low negative pressure is applied to the expiratory valve



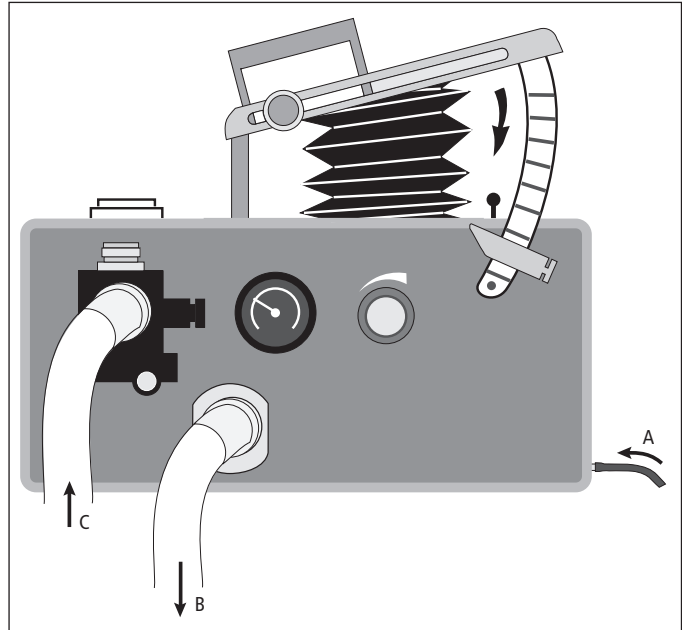

**Figure 2.15** Diagram and photograph of a gravity-powered ventilator. A, anaesthetic gas input; B, anaesthetic gas output to patient; C, expired gas from patient.

of the breathing system or ventilator to remove gases to the outside environment. The patient is protected against excessive negative pressure being applied to the lungs by valves with very low opening pressures. The use of such systems does not eliminate the problem of pollution; it merely shifts it from one site to another. Inhalational anaesthetics, particularly nitrous oxide, are potent destroy-

ers of ozone, thereby adding to the greenhouse effect.

### Measurement and monitoring

Measurement and monitoring are closely linked but are not synonymous. A measuring instrument becomes a monitor when it is capable of delivering

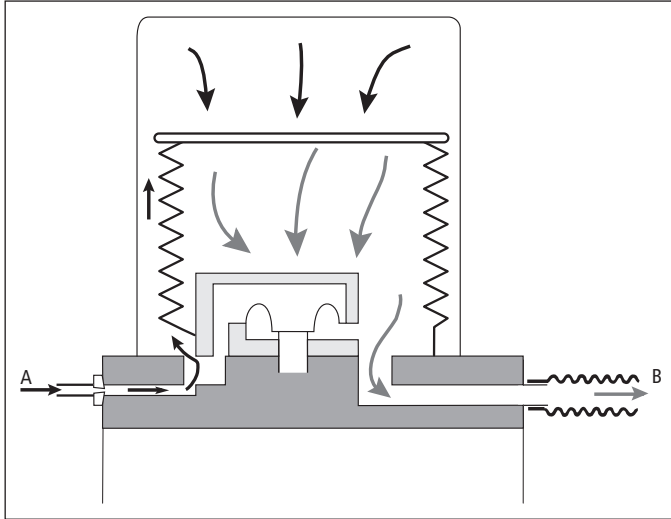

**Figure 2.16** Photograph and diagram of bag-in-bottle ventilator. A, high-pressure driving gas input; B, anaesthetic gas output to patient.

a warning when the variable being measured falls outside preset limits. During anaesthesia, both the patient and the equipment being used are monitored, the complexity of which depends upon a variety of factors including:

- type of operation and operative technique;
- anaesthetic technique used;
- present and previous health of the patient;
- equipment available and the anaesthetist's ability to use it;



**Figure 2.17** Modern electronic ventilator. None of the components are visible. Close-up of the control panel shows soft keys, allowing choice of mode of ventilation and volumes and pressures during controlled ventilation (IPPV).

- preferences of the anaesthetist;
- any research being undertaken.

Clearly, the anaesthetist has a responsibility to check the function of all monitoring equipment before use and ensure that the alarm limits are set appropriately.

There is good evidence that monitoring reduces the risks of adverse incidents and accidents. The combination of pulse oximetry, capnography and blood pressure monitoring detects the majority of serious incidents before the patient suffers serious injury. Monitoring should commence before the induction of anaesthesia and continue until the patient has recovered from the effects of anaesthesia, and the information generated should be recorded in the patient's notes. Ultimately, monitors supplement clinical observation; there is no substitute for the presence of a trained and experienced anaesthetist throughout the entire operative procedure.

Monitoring is not without its own potential hazards: faulty equipment may endanger the patient, for example from electrocution secondary to faulty earthing; the anaesthetist may act on faulty data, instituting inappropriate treatment; or the patient may be harmed by the complications of the technique to establish invasive monitoring, for example pneumothorax following central line insertion. Ultimately, too many monitors may distract the anaesthetist from recognizing problems occurring in other areas.

## Monitoring the patient

The AAGBI recommends certain monitoring devices as *essential* for the safe conduct of anaesthesia. These consist of:

- ECG;
- non-invasive blood pressure;
- pulse oximeter;
- capnography;
- vapour concentration analyser.

In addition, the following monitors should be *immediately available*:

- peripheral nerve stimulator;
- temperature.

Finally, additional equipment *will be required* in certain cases, to monitor, for example:

- invasive blood pressure;
- urine output;
- central venous pressure;
- pulmonary artery pressure;
- cardiac output.

## Essential monitors

### The ECG

This is easily applied and gives information on heart rate and rhythm, and may warn of the presence of ischaemia and acute disturbances of certain electrolytes (e.g. potassium and calcium). It can be monitored using three leads applied to the right shoulder (red), the left shoulder (yellow) and the left lower chest (green), to give a tracing equivalent to standard lead II of the 12-lead ECG. Many ECG

monitors now use five electrodes placed on the anterior chest to allow all the standard leads and V5 to be displayed. The ECG alone gives no information on the adequacy of the cardiac output and it must be remembered that it is possible to have a virtually normal ECG in the absence of any cardiac output.

### Non-invasive blood pressure

This is the most common method of obtaining the patient's blood pressure during anaesthesia and surgery. A pneumatic cuff with a width that is 40% of the arm circumference must be used and the internal inflatable bladder should encircle at least half the arm. If the cuff is too small, the blood pressure will be overestimated, and if it is too large it will be underestimated. Auscultation of the Korotkoff sounds is difficult in the operating theatre and automated devices (Fig. 2.18) are widely used. An electrical pump inflates the cuff, which then undergoes controlled deflation. A microprocessor-controlled pressure transducer detects variations in cuff pressure resulting from transmitted arterial pulsations. Initial pulsations represent systolic blood pressure and peak amplitude of the pulsations equates to mean arterial pressure. Diastolic blood pressure is calculated using an algorithm. Heart rate is also determined and displayed. The frequency at which blood pressure is estimated can be set along with values for blood pressure, outside which an alarm sounds. Such devices cannot measure pressure continually and become increasingly inaccurate at extremes of pressure and in patients with an arrhythmia.

### Pulse oximeter

A probe, containing a light-emitting diode (LED) and a photodetector, is applied across the tip of a digit or earlobe. The LED alternately emits red light at two different wavelengths in the visible and infrared regions of the electromagnetic spectrum. These are transmitted through the tissues and absorbed to different degrees by oxyhaemoglobin and deoxyhaemoglobin. The intensity of light

reaching the photodetector is converted to an electrical signal. The absorption due to the tissues and venous blood is static. This is then subtracted from the beat-to-beat variation due to arterial blood, to display the peripheral arterial oxygen saturation ( $SpO_2$ ), both as a waveform and digital reading (see Fig. 2.18). Pulse oximeters are accurate to  $\pm 2\%$ . The waveform can also be interpreted to give a reading of heart rate. Alarms are provided for levels of saturation and heart rate. The pulse oximeter therefore gives information about both the circulatory and respiratory systems and has the advantages of:

- providing continuous monitoring of oxygenation at tissue level;
- being unaffected by skin pigmentation;
- portability (mains or battery powered);
- being non-invasive.

Despite this, there a number of important limitations of this device:

- There is failure to realize the severity of hypoxia;



**Figure 2.18** Integrated monitoring system displaying ECG and heart rate (beats/min), non-invasive blood pressure (mmHg), capnograph and end tidal carbon dioxide (kPa), pulse oximeter waveform and saturation (%).

a saturation of 90% equates to a  $P_{aO_2}$  of 8 kPa (60 mmHg) because of the shape of the haemoglobin dissociation curve.

- It is unreliable when there is severe vasoconstriction due to the reduced pulsatile component of the signal.
- It is unreliable with certain haemoglobins:
  - when carboxyhaemoglobin is present, it overestimates  $SaO_2$ ;
  - when methaemoglobin is present, at an  $SaO_2 > 85\%$ , it underestimates the saturation.
- It progressively under-reads the saturation as the haemoglobin falls (but it is not affected by polycythaemia).
- It is affected by extraneous light.
- It is unreliable when there is excessive movement of the patient.

The pulse oximeter is not an indicator of the adequacy of alveolar ventilation.

Hypoventilation can be compensated for by increasing the inspired oxygen concentration to maintain oxygen saturation.

**Table 2.10** Uses of end-tidal  $CO_2$  measurement

- An indicator of the degree of alveolar ventilation:
  - to ensure normocapnia during mechanical ventilation
  - control the level of hypocapnia in neurosurgery
  - avoidance of hypocapnia where the cerebral circulation is impaired, e.g. the elderly
- As a disconnection indicator (the reading suddenly falls to zero)
- To indicate that the tracheal tube is in the trachea ( $CO_2$  in expired gas)
- As an indicator of the degree of rebreathing (presence of  $CO_2$  in inspired gas)
- As an indicator of cardiac output. If cardiac output falls and ventilation is maintained, then end-tidal  $CO_2$  falls as  $CO_2$  is not delivered to the lungs, e.g.:
  - hypovolaemia
  - cardiac arrest, where it can also be used to indicate effectiveness of external cardiac compression
  - massive pulmonary embolus
- It may be the first clue of the development of malignant hyperpyrexia (see page 98)

## Capnography

The capnograph (see Fig. 2.18) works on the principle that carbon dioxide ( $CO_2$ ) absorbs infrared light in proportion to its concentration. In a healthy person, the  $CO_2$  concentration in alveolar gas (or partial pressure,  $P_{ACO_2}$ ) correlates well with partial pressure in arterial blood ( $P_{aCO_2}$ ), with the former being slightly lower, by 5 mmHg or 0.7 kPa. Analysis of expired gas at the end of expiration (i.e. *end-tidal*  $CO_2$  concentration) reflects  $P_{aCO_2}$ . Capnography is used primarily as an indicator of the adequacy of ventilation;  $P_{aCO_2}$  is inversely proportional to alveolar ventilation. In patients with a low cardiac output (e.g. hypovolaemia, pulmonary embolus), the gap between arterial and end-tidal carbon dioxide increases (end-tidal falls), mainly due to the development of increased areas of ventilation/perfusion mismatch. The gap also increases in patients with chest disease due to poor mixing

of respiratory gases. Care must be taken in interpreting end-tidal  $CO_2$  concentrations in these circumstances. Modern capnographs have alarms for when the end-tidal carbon dioxide is outside preset limits. Other uses of carbon dioxide monitoring are given in Table 2.10.

## Vapour concentration analyser

Whenever a volatile anaesthetic is administered the inspired concentration in gas mixture should be monitored. This is usually achieved using infrared absorption, similar to carbon dioxide. The degree of absorption is dependent specifically on the volatile and its concentration. A single device can be calibrated for all of the commonly used inhalational anaesthetics.

In many modern anaesthesia systems the above monitors are integrated and displayed on a single screen (Fig. 2.18).

## Immediately available monitors

### Peripheral nerve stimulator

See page 35.

### Temperature

During anaesthesia the patient's temperature is usually monitored continually. The most commonly used device is a thermistor, the resistance of which is temperature dependent. This can be placed in the oesophagus (cardiac temperature) or nasopharynx (brain temperature). The rectum can be used but, apart from being unpleasant, faeces may insulate the thermistor, leading to inaccuracies. An infrared tympanic membrane thermometer can be used intermittently, but the external auditory canal must be clear. Most patients' core temperature falls during anaesthesia as a result of exposure to a cold environment, evaporation of fluids from body cavities, the administration of cold intravenous fluids and breathing dry, cold anaesthetic gases. This is compounded by the loss of body temperature regulation and inability to shiver. These can be minimized by forced air warming, warming all fluids (particularly blood), heating and humidifying inspired gases, and covering exposed areas. Apart from monitoring cooling, a sudden unexpected rise in a patient's temperature may be the first warning of the development of malignant hyperpyrexia (see page 98).

## Additional monitors

### Invasive or direct blood pressure

This is the most accurate method for measuring blood pressure and is generally reserved for use in complex, prolonged surgery or sick patients. A cannula is inserted into a peripheral artery and connected to a transducer that converts the pressure signal to an electrical signal. This is then amplified and displayed as both a waveform and blood pressure (see Fig. 5.3).

### Urine output

Measurement of urine output is performed during prolonged surgery to ensure maintenance of adequate circulating volume where there is likely to be major blood loss, where diuretics are used (e.g. neurosurgery) and in all critically ill patients. Urine output needs to be measured at least hourly, aiming for a flow of approximately 1 mL/kg/h. Failure to produce urine indicates that renal blood flow is inadequate, as well as the flow to the other vital organs (heart and brain). Catheterization also eliminates bladder distension or incontinence.

### Central venous pressure (CVP)

This is measured by inserting a catheter via a central vein, usually the internal jugular or subclavian, so that its tip lies at the junction of the superior vena cava and right atrium. It is then connected via a fluid-filled tube to a transducer that converts the pressure signal to an electrical signal. This is then amplified and displayed as both a waveform and pressure.

Loss of circulating volume will reduce venous return to the heart, diastolic filling and preload, and be reflected as a low or falling CVP. Although absolute values of the CVP can be measured, trends are usually more informative. Often a 'fluid challenge' is used in the face of a low CVP. The CVP is measured, a rapid infusion of fluid is given (3–5 mL/kg) and the change in CVP noted. In the hypovolaemic patient the CVP increases briefly and then falls to around the previous value, whereas in the fluid-replete patient the CVP will rise to a greater extent and be sustained. Overtransfusion will be seen as a high, sustained CVP.

CVP is usually monitored in operations during which there is the potential for major fluid shifts (e.g. prolonged abdominal surgery) or blood loss (e.g. major orthopaedic and trauma surgery). It is affected by a variety of other factors apart from fluid balance (Table 2.11), in particular cardiac function. Hypotension in the presence of an elevated CVP (absolute or in response to a fluid challenge) may indicate heart failure, but most clinicians would now accept that measurement of the pressures on the

**Table 2.11** Factors affecting the central venous pressure

- The zero reference point
- Patient posture
- Fluid status
- Heart failure
- Raised intrathoracic pressure:
  - mechanical ventilation
  - coughing
  - straining
- Pulmonary embolism
- Pulmonary hypertension
- Tricuspid valve disease
- Pericardial effusion, tamponade
- Superior vena cava obstruction

left side of the heart using a pulmonary artery flotation catheter is preferable to assist in the management of this condition (see page 126).

### Pulmonary artery catheter and cardiac output

See page 126.

### Blood loss

Simple estimates of blood loss during surgery are easily performed. Swabs can be weighed, dry and wet, the increase in weight giving an indication of the amount of blood they have absorbed. The volume of blood in the suction apparatus can be measured, with allowance for irrigation fluids. Such methods are only estimates, as blood may remain in body cavities, be spilt on the floor and absorbed by drapes and gowns. In paediatric practice, where small volumes of blood loss are relatively more important, all absorbent materials are washed to remove the blood and the resultant solvent assayed colorimetrically to estimate blood loss.

### Monitoring the equipment

With the increasing reliance on complex equipment to deliver anaesthesia, the AAGBI recommends that there should be continuous monitoring of the continuity of the oxygen supply and correct functioning of the breathing system.

### Oxygen supply

All anaesthetic machines are fitted with a device warning of oxygen supply failure (see page 42). Continuous monitoring of the oxygen concentration in the inspired gas mixture is considered essential. This is usually achieved using a fuel cell oxygen analyser that produces a current proportional to the oxygen concentration, displayed as a numeric value of oxygen concentration. *It must be remembered that the inspired oxygen concentration does not guarantee adequate arterial oxygen saturation* as it may be insufficient to compensate for the effects of hypoventilation and ventilation/perfusion mismatch (see page 72).

### Breathing systems

Irrespective of whether the patient is breathing spontaneously or being ventilated, capnography will detect most of the common problems, for example disconnection (loss of reading), inadequate gas flow (increased *end-tidal CO<sub>2</sub>*), hyper/hypoventilation (decreased/increased *end-tidal CO<sub>2</sub>*, respectively). In addition, when a patient is ventilated, airway pressures must be monitored to avoid excessive pressures being generated within the lungs. Airway pressure monitoring can also be used as a secondary indicator of inadequate ventilation in ventilated patients; high pressures may be the result of obstruction (e.g. blocked tracheal tube, bronchospasm), and loss of pressure the result of a disconnection. The latter function may be specifically used as a 'disconnection alarm'.

Many other physiological parameters can be, and are, monitored during anaesthesia when appropriate. Some examples are: clotting profiles in patients receiving a transfusion of a large volume of stored blood; blood glucose in diabetic patients; and arterial blood gas and acid-base analysis during the bypass phase of cardiac surgery. Recently, interest has been shown in the development of monitors that give information relating to the depth of anaesthesia, but these are still under investigation.

Finally, it is essential to recognize that the above standards apply not only to those patients

undergoing general anaesthesia, but also those receiving sedation, local or regional anaesthesia and during transfer.

### The anaesthetic record

On every occasion an anaesthetic is administered, a comprehensive and *legible* record must be made. The details and method of recording will vary with each case, the type of chart used and the equipment available. Apart from the value to future anaesthetists who encounter the patient, particularly when there has been a difficulty (e.g. with intubation), the anaesthetic record is a medicolegal document, to which reference may be necessary after several years. An anaesthetic chart typically allows the following to be recorded:

- preoperative findings, ASA grade, premedication;
- details of previous anaesthetics and any difficulties;
- apparatus used for the current anaesthetic;
- monitoring devices used;
- anaesthetic and other drugs administered: timing, dose and route;
- vital signs at various intervals, usually on a graphical section;
- fluids administered and lost: type and volume;
- use of local or regional anaesthetic techniques;
- anaesthetic difficulties or complications;
- postoperative instructions.

Increasingly, electronic records are being developed. These have the advantage of allowing the anaesthetist to concentrate on caring for the patient, particularly during an emergency, rather than having to stop and make a record or try to fill in the record retrospectively.

### Intravenous cannulation and fluid administration

Intravenous cannulation is used to allow:

- drugs to be given to induce and maintain anaesthesia;
- fluids to be given to maintain or restore the patient's circulating volume;
- monitoring of intravascular pressures.

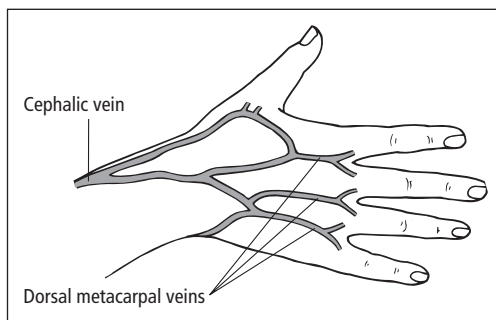

**Figure 2.19** Typical distribution of veins on the dorsum of the hand. After Warwick R & Williams PL (eds) *Gray's Anatomy*, 35th edn. Edinburgh: Churchill Livingstone, 1973.

The superficial veins in the upper limbs are most commonly used.

### Anatomy of the veins in the upper limb

#### The dorsum of the hand and forearm

The veins draining the fingers unite to form three *dorsal metacarpal veins*. Laterally these are joined by veins from the thumb and continue up the radial border of the forearm as the *cephalic vein* (Fig. 2.19). Medially the metacarpal veins unite with the veins from the little finger and pass up the ulnar border of the forearm as the *basilic vein*. There is often a large vein in the middle of the ventral (anterior) aspect of the forearm—the *median vein of the forearm* (Fig. 2.20).

#### The antecubital fossa

The cephalic vein passes through the antecubital fossa on the lateral side and the basilic vein enters the antecubital fossa very medially, just in front of the medial epicondyle of the elbow. These veins are joined by the *median cubital* or *antecubital vein* (see Fig. 2.20). Veins in this region tend to be used either in an emergency situation or when attempts to cannulate more peripheral veins have failed. It must be remembered that the brachial artery, the



**Figure 2.20** Typical distribution of veins of the forearm and antecubital fossa (right arm). After Warwick R & Williams PL (eds) *Gray's Anatomy*, 35th edn. Edinburgh: Churchill Livingstone, 1973.

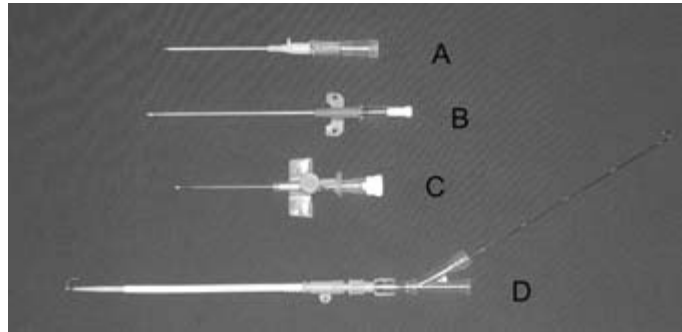
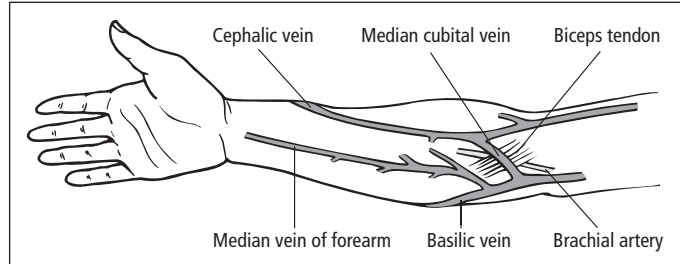

**Figure 2.21** (A–D) Different types of intravenous cannula.

median nerve and branches of the medial and lateral cutaneous nerves of the arm are in close proximity and easily damaged by needles or extravasated drugs.

## Equipment

Devices of different lengths and diameters are used; the term 'cannula' is used for those 7 cm or less in length, and 'catheter' for those longer than 7 cm. The external diameter of these devices is quoted either in terms of its 'gauge' (diameter increases with decreasing gauge) or millimetres. The main types of cannulae used are:

- *Cannula over needle* The most popular device, available in a variety of sizes, most commonly 14 gauge (2.1 mm) to 22 gauge (0.8 mm). A plastic (PTFE or similar material) cannula is mounted on a smaller diameter metal needle, the bevel of which protrudes from the cannula. The other end of the needle is attached to a transparent 'flashback

chamber', which fills with blood once the needle bevel lies within the vein (Fig. 2.21A). Some devices have flanges or 'wings' to facilitate attachment to the skin (Fig. 2.21B). All cannulae have a standard Luer-lock fitting for attaching a giving set and some have a valved injection port through which drugs can be given (Fig. 2.21C).

- *Seldinger type* This is used predominantly to achieve cannulation of the central veins (see below), but peripheral devices are available, designed mainly for use in resuscitation, for example the Arrow EID cannula (Fig. 2.21D).

## Technique for cannulation of a peripheral vein

The superficial veins are situated immediately under the skin in the superficial fascia, along with a variable amount of subcutaneous fat. They are relatively mobile and capable of considerable variation in their diameters. The size of cannula used

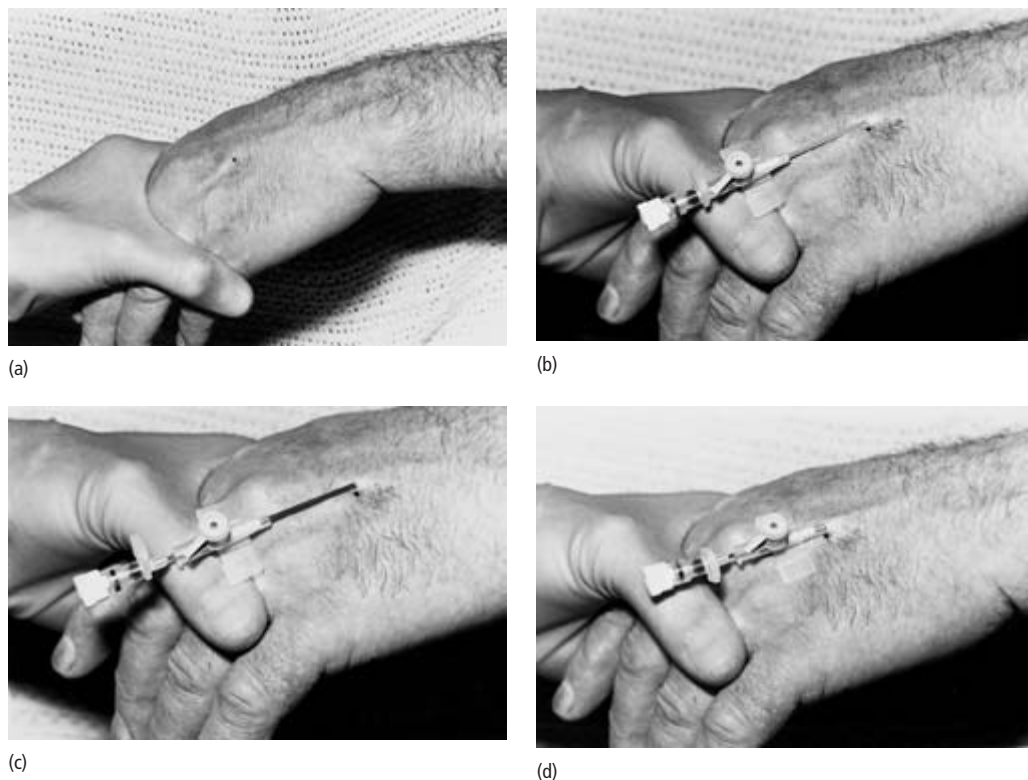

**Figure 2.22** (a-d) Peripheral intravenous cannulation. Courtesy of Greaves I, Hodgetts T, Porter K. *Emergency Care—A Textbook for Paramedics*. London: Harcourt Brace, 1997.

will depend upon its purpose: large-diameter cannulas are required for giving fluid rapidly, smaller ones are adequate for giving drugs and maintenance fluids.

As with any procedure where there is a risk of contact with body fluids, gloves should be worn by the operator.

- Choose a vein capable of accommodating the size of cannula needed, preferably one that is both visible and palpable.
  - The junction of two veins is often a good site as the 'target' is relatively larger.
  - Avoid veins over joints as the cannula may kink if the joint is flexed, with loss of function.
  - Veins distal to fractures should also be

avoided as drugs or fluids may leak from the fracture site.

- Encourage the vein to dilate by applying a tourniquet proximally and gently tapping the skin over the vein. Warming a cold hand will also help.
- Clean the skin over the vein using either an alcohol- or iodine-based solution (ensure there is no risk of allergy if iodine is used).
- A small amount of local anaesthetic (0.2 mL lignocaine 1%) should be infiltrated into the skin at the site chosen for venepuncture using a 25 gauge (0.5 mm) needle, particularly if a large (>18 gauge, 1.2 mm) cannula is used. This reduces pain, and makes the patient less likely to move and less resistant to further attempts.
- Immobilize the vein to prevent it being displaced by the cannula, by pulling the overlying skin tight, using your spare hand (Fig. 2.22a).

- Advance the cannula through the skin at an angle of 10–15° and then into the vein. Often a slight loss of resistance is felt as the vein is entered and this should be accompanied by the appearance of blood in the flashback chamber of the cannula (Fig. 2.22b). This indicates that the tip of the needle is within the vein.
- Reduce the angle of the cannula slightly and advance it a further 2–3 mm into the vein, keeping the skin taut. This ensures that the first part of the plastic cannula lies within the vein. Take care not to push the needle out of the far side of the vein!
- Withdraw the needle 5–10 mm into the cannula so that the bevel no longer protrudes from the end. As this is done, blood may be seen to flow between the needle body and the cannula, confirming that the tip of the cannula is within the vein (Fig. 2.22c).
- The cannula and needle should now be advanced *together* along the vein. The needle is retained within the cannula to provide support and prevent kinking at the point of skin puncture (Fig. 2.22d).
- Once the cannula is fully inserted the tourniquet should be released, and the needle removed and disposed of safely.
- Confirm that the cannula lies within the vein by attaching an IV infusion and ensuring it runs freely. Alternatively, inject a small volume of saline. Immediate, localized swelling or pain indicates that the cannula is incorrectly positioned. Do not persist; remove it and try at another site.
- Finally, secure the cannula in an appropriate manner with adhesive tape, or a commercial dressing.

## Complications

Most are relatively minor but this must not be used as an excuse for carelessness and poor technique.

- *Failure* Usually a result of pushing the needle completely through the vein. It is always best to attempt cannulation distally in a limb and work proximally. If multiple attempts are required, fluid or drugs will not leak from previous puncture sites.
- *Haematoma* Usually secondary to the above

with inadequate pressure applied over the puncture site to prevent bleeding, and made worse by forgetting to remove the tourniquet!

- *Extravasation of fluid or drugs* Failing to recognize that the cannula is not within the vein before use. The degree of damage to the overlying tissues will depend primarily upon the nature of the extravasated fluid.
- *Damage to local structures* Secondary to poor technique and lack of knowledge of the local anatomy.
- *Air embolus* The peripheral veins normally collapse when empty. However, a cannula may prevent this and allow air to enter the circulation. Most likely following cannulation of a central vein (see below).
- *Shearing of the cannula* Usually a result of trying to reintroduce the needle after it has been withdrawn. The safest action is to withdraw the whole cannula and re-attempt at another site.
- *Thrombophlebitis* Related to the length of time the vein is in use and irritation caused by the substances flowing through it. High concentrations of drugs and fluids with extremes of pH or high osmolality are the main causes, for example antibiotics, calcium chloride, sodium bicarbonate. Once a vein shows signs of thrombophlebitis (i.e. tender, red and deteriorating flow) the cannula must be removed to prevent subsequent infection or thrombosis.

## Central venous cannulation

This may be used for a variety of reasons during anaesthesia: to monitor the cardiovascular system; because of inadequate peripheral venous access; and to give certain drugs (e.g. inotropes). There are many different types of equipment and approaches to the central veins, and the following is intended as an outline. The use of an ultrasound scanner may improve the detection and needle localization of central veins.

**Table 2.12** Complications of central venous cannulation

- Arterial puncture and bleeding causing haematoma or haemothorax
- Air embolus
- Venous thrombosis
- Pneumothorax
- Thoracic duct injury (left side) and chylothorax
- Hydrothorax if the catheter is intrapleural and fluid given
- Bacteraemia
- Septicaemia
- Soft tissue infection at puncture site
- Injury to nerves:
  - brachial plexus
  - recurrent laryngeal
  - phrenic

## Access to the central veins

### The antecubital fossa

This route has a relatively low success rate, but fewer complications, the most important of which is thrombophlebitis after prolonged use (>48 h). The basilic vein is preferable, as a catheter passed via this vein is most likely to reach beyond the clavipectoral fascia.

### The internal jugular vein

This approach is associated with the highest incidence of success (95%), and a low rate of complications (Table 2.12). The right internal jugular offers certain advantages: there is a 'straight line' to the heart, the apical pleura does not rise as high on this side, and the main thoracic duct is on the left.

### Subclavian vein

This can be approached by both the supra- and infraclavicular routes. Both are technically more difficult than the internal jugular route and there is a significant incidence of causing a pneumothorax (≈2%). The main advantage of this route is comfort for the patient during long-term use.

Bilateral attempts at central venous cannulation must not be made because of the risk of airway

obstruction due to haematoma formation in the neck or bilateral pneumothoraces.

Whenever a CVP catheter is inserted, a chest X-ray must be taken to ensure that the catheter is correctly positioned and a pneumothorax has not been caused.

## Equipment for central venous catheterization

Three types of catheter are commonly used for percutaneous cannulation of the central veins:

- *Catheter over needle* Similar to a peripheral IV cannula, the main difference is that it is longer to ensure that the tip lies in the correct position within a central vein.
- *Seldinger technique* The vein is initially punctured percutaneously using a small-diameter needle. A flexible guidewire is then passed down the needle into the vein and the needle carefully withdrawn, leaving the wire behind. The catheter is now passed over the wire into the vein, sometimes preceded by a dilator. The advantage of this method is that the initial use of a small needle increases the chance of successful venepuncture and reduces the risk of damage to the vein.
- *Catheter through needle* A large-diameter needle is introduced into the vein, the catheter is threaded down the lumen and the needle is withdrawn, leaving the catheter in place.

## Fluid flow through a cannula

This determined by four factors:

- *Internal diameter* Theoretically, flow is proportional to the fourth power of the radius. Doubling the diameter should result in flow increasing 16-fold ( $2^4$ ). This is rarely achieved in practice, but an increase of four- to fivefold will be seen.
- *Length* Flow is inversely proportional to the length of the cannula—doubling the length will halve the flow.
- *Viscosity* Flow is inversely proportional to the viscosity of the fluid—increasing viscosity reduces flow. Colloids and blood flow more slowly than a crystalloid, particularly when they are cold.

- **Pressure** Increasing the pressure across the cannula will increase the flow. This is usually achieved by either raising the height of the drip above the patient or using external pressure.

Always use a large-diameter, short cannula during resuscitation as the rate of flow is determined primarily by the diameter.

## Intravenous fluids

During anaesthesia fluids are given intravenously to replace losses due to surgery and provide the patient's normal daily requirements. Three types are used: crystalloids, colloids, and blood and its components.

### Crystalloids

These are solutions of crystalline solids in water. A wide variety is available and a summary of the composition of the most commonly used is shown in Table 2.13. Those containing sodium in similar

concentrations to plasma are rapidly distributed throughout the extracellular fluid space (i.e. intravascular and interstitial volumes). Ultimately, only 25–30% of the volume administered remains intravascular. If such fluids are used to restore the circulating volume, three to four times the deficit will need to be given. If crystalloids containing a lower concentration of sodium than plasma (e.g. 4% glucose plus 0.18% saline) are given, then once the glucose is metabolized the remaining fluid is distributed throughout the entire body water (i.e. extracellular and intracellular volumes), and as little as 10% will remain intravascular. Crystalloids are used primarily either as an emergency resuscitation fluid or to provide a patient's daily requirements of water and sodium.

### Colloids

These are suspensions of high molecular weight particles. The most commonly used are derived from gelatin (Haemaccel, Gelofusine), protein (albumin) or starch (Hespan, HAES-steril). A summary of their composition is shown in Table 2.14.

**Table 2.13** Composition of crystalloids

Crystalloid	Na <sup>+</sup> (mmol/L)	K <sup>+</sup> (mmol/L)	Ca <sup>++</sup> (mmol/L)	Cl <sup>-</sup> (mmol/L)	HCO <sub>3</sub> <sup>-</sup> (mmol/L)	pH	Osmolality (mosmol/L)
Hartmann's	131	5	4	112	29*	6.5	281
0.9% sodium chloride	154	0	0	154	0	5.5	300
4% glucose plus 0.18% sodium chloride	31	0	0	31	0	4.5	284
5% glucose	0	0	0	0	0	4.1	278

\* Present as lactate which is metabolized to bicarbonate by the liver.

**Table 2.14** Composition of colloids

Colloid	Average molecular weight (kDa)	Na <sup>+</sup> (mmol/L)	K <sup>+</sup> (mmol/L)	Ca <sup>++</sup> (mmol/L)	Cl <sup>-</sup> (mmol/L)	HCO <sub>3</sub> <sup>-</sup> (mmol/L)	pH	Osmolality (mosmol/L)
Haemaccel	35	145	5	6.2	145	0	7.3	350
Gelofusine	35	154	0.4	0.4	125	0	7.4	465
Albumin	69	130–160	2	0	120	0	6.7–7.3	270–300
Starch	140–400	154	0	0	154	0	5.5	310

Colloids primarily expand the intravascular volume and can initially be given in a volume similar to the deficit to maintain the circulating volume. However, they have a finite life in the plasma and will eventually be either metabolized or excreted and therefore need replacing.

## Blood and blood components

There are several forms of blood and its components available. In the intraoperative period the most commonly used are red cell products, platelet concentrates and clotting factors.

- *Whole blood* Despite its name, this is basically red cells, plasma proteins and clotting factors (levels of V and VIII are low). There are no platelets. Each unit contains approximately 510 mL with a haematocrit of 35–45%. Not widely available.

- *Red cell concentrate* This is the by-product of the removal of plasma from whole blood. Each unit contains 250 mL with a haematocrit of 60–75%, and is hence very viscous with a poor flow rate.

- *Red cells in optimal additive solution (SAG-M)* A red cell concentrate to which a mixture of saline, adenine and glucose and mannitol has been added. This improves both red cell survival and flow characteristics. Each unit contains  $\approx$ 300 mL with a haematocrit of 50–70%. White cells are routinely removed in the UK to prevent the risk of prion transmission.

- *Platelet concentrates* Supplied either as ‘units’ containing 50–60 mL ( $55 \times 10^9$  platelets) or as bags equivalent to four units. Four units or one bag will raise the platelet count by 30–40 000  $\text{mm}^3$ . Given via a standard giving set *without* the use of a microaggregate filter, as this will result in the loss of significant numbers of platelets.

- *Fresh frozen plasma (FFP)* This consists of the plasma separated from a single donation and frozen within 6 h. Each pack contains 200–250 mL, with normal levels of clotting factors (except factor VIII, 70% normal). It should be infused as soon as it has thawed.

- *Cryoprecipitate* This is produced as a precipitate formed on the controlled thawing of FFP, which is collected and suspended in plasma. It contains large amounts of factor VIII and fibrinogen. It is

supplied as a pooled donation from six packs of FFP in one unit and must be used as soon as possible after thawing.

## Risks of intravenous blood and blood products

All blood donations are routinely tested for hepatitis B surface antigen, hepatitis C, syphilis and antibodies to the HIV. However, a period exists between exposure and the development of antibodies. The resultant infected red cells would not be detected by current screening techniques. The risk is very small, and has been estimated for hepatitis B at 1:10<sup>5</sup> and for HIV at 1:10<sup>6</sup> units transfused. In order to try and eliminate these risks, techniques now exist for using the patient’s own blood in the perioperative period.

- *Predepositing blood* Over a period of 4 weeks prior to surgery, the patient builds up a bank of two to four units of blood for retransfusion perioperatively.

- *Preoperative haemodilution* Following induction of anaesthesia 0.5–1.5 L of blood is removed and replaced with colloid. This can then be transfused at the end of surgery.

- *Cell savers* These devices collect blood lost during surgery via a suction system; the red cells are separated, washed and resuspended, ready for retransfusion to the patient.

## Intraoperative fluid administration

The type and volume of fluid administered during surgery varies for each and every patient, but must take into account:

- any deficit the patient has accrued;
- maintenance requirements during the procedure;
- losses due to surgery;
- any vasodilatation secondary to the use of a regional anaesthetic technique (see page 67).

## The accrued deficit

This may be due to preoperative fasting, or losses as a result of vomiting, haemorrhage or pyrexia. Any

deficit due to fasting is predominantly water from the total body water volume. The volume required is calculated at the normal daily maintenance rate of 1.5 mL/kg/h (from the point at which fasting began). Although this deficit can be replaced with a fluid such as 4% glucose plus 0.18% saline, Hartmann's solution is widely used intraoperatively. The other main cause of a preoperative deficit is losses either from or into the gastrointestinal tract. This fluid usually contains electrolytes and effectively depletes the extracellular volume. It is best replaced with a crystalloid of similar composition, particularly in respect of the sodium concentration; for example 0.9% sodium chloride or Hartmann's solution.

Acute blood loss preoperatively can be replaced with either an appropriate volume of crystalloid (remembering that only 30% remains intravascular) or colloid. If more than 20% of the estimated blood volume has been lost (approximately 1000 mL), blood should be used, particularly if bleeding is ongoing.

### Intraoperative requirements

Maintenance fluids alone are usually only given when surgery is prolonged (>1–2h), or if there is the possibility of a delay in the patient resuming oral fluid intake. Most patients will compensate for a preoperative deficit by increasing their oral intake postoperatively. When maintenance fluid is used it should be given at 1.5 mL/kg/h, and increased if the patient is pyrexial by 10% for each degree centigrade above normal.

Losses during surgery are due to:

- *Evaporation* This can occur during body cavity surgery or when large areas of tissue are exposed, depleting the total body water.
- *Trauma* The formation of tissue oedema, the volume of which is dependent upon the extent of tissue damage; it is similar in composition to extracellular fluid. This fluid is often referred to as 'third space loss' and creates a deficit in the circulating volume that can no longer be accessed.
- *Blood loss* This will depend upon the type and site of surgery.

Fluid losses from the first two causes are difficult to measure and are extremely variable. If evaporative losses are considered excessive, then 4% glucose plus 0.18% saline can be used. Third space losses should be replaced with a solution similar in composition to extracellular fluid, and Hartmann's is commonly used. The rate of administration and volume required is proportional to surgical trauma and may be as much as 10 mL/kg/h. Blood pressure, pulse, peripheral perfusion and urine output will give an indication as to the adequacy of replacement, but in complex cases where there are other causes of fluid loss, particularly bleeding, the trend of the CVP is very useful (see page 52).

Blood loss is slightly more obvious and easier to measure. Most previously well patients will tolerate the anaemia that results from the loss of 20% of their blood volume, providing that the circulating volume is adequately maintained by the use of crystalloids or colloids. Beyond this, red cell preparations are used in order to maintain the oxygen-carrying capacity of the blood. A haemoglobin level between 8 and 10 g/dL is a safe level even for those patients with serious cardiorespiratory disease. In most cases, the equivalent of the patient's estimated blood volume can be replaced with red cell concentrates, crystalloid and colloid in the appropriate volumes. Occasionally, blood loss is such that the haemostatic mechanisms are affected. This may be seen as continuous oozing from the surgical wound or around IV cannulation sites. If this is suspected, the patient's coagulation status must be confirmed (platelet count, PT, APTT, fibrinogen levels). Platelets may not be required until losses exceed 1.5 times the estimated blood volume. Treatment is usually reserved for those cases in which the INR reaches 1.7–2.0, fibrinogen levels fall below 0.5 g/L or the platelet count falls below  $50 \times 10^9/L$ .

### Local and regional anaesthesia

When referring to local and regional techniques and the drugs used, the terms 'analgesia' and 'anaesthesia' are used loosely and interchangeably. For clarity and consistency the following terms will be used:



Table 2.15 Local anaesthetic drugs

Drug	Dose	Speed of onset	Duration of action	Comments
Lignocaine	3 mg/kg (plain), max. 200 mg 6 mg/kg (with epinephrine), max. 500 mg	Rapid	60–180 mins, depending on the technique used	Used: topically, infiltration, nerve blocks, IVRA, epidurally, intrathecally
Bupivacaine	2 mg/kg, max. 150 mg (± epinephrine) in any 4 h period	Nerve block: up to 40 mins Epidurally: 15–20 mins Intrathecal: 30 s	Up to 24 h 3–4 h, dose dependent 2–3 h, dose dependent	Mainly used for nerve blocks, epidurally and intrathecally. Relatively cardiotoxic
Levo bupivacaine	An isomer of bupivacaine; most properties very similar, but less cardiotoxic. This allows slightly higher doses to be given			
Ropivacaine	3 mg/kg, max. 200 mg	Similar to bupivacaine	For the same concentration and technique, shorter than bupivacaine	At lower concentrations, relatively less intense motor block than bupivacaine

IVRA: intravenous regional anaesthesia.

- **Analgesia** The state when only relief of pain is provided. This may allow some minor surgical procedures to be performed, for example infiltration analgesia for suturing.
- **Anaesthesia** The state when analgesia is accompanied by muscle relaxation, usually to allow major surgery to be undertaken. Regional anaesthesia may be used alone or in combination with general anaesthesia.

All drugs will be referred to as local anaesthetics irrespective of the technique for which they are being used.

## Local anaesthetic drugs

### EMLA

This is a *eutectic mixture* of local anaesthetics lignocaine and prilocaine in equal proportions (25 mg of each per gram). It is applied as a cream to the skin and produces surface analgesia in approximately 60 mins. It is used to reduce the pain associated with venepuncture in children.

### Ametop

This is a topical preparation of 4% amethocaine. It is used like EMLA to produce surface analgesia, but in a slightly shorter time.

A synopsis of the drugs used for local and regional anaesthesia is given in Table 2.15.

### Epinephrine (adrenaline)

This is added to local anaesthetics to reduce the rate of absorption, reduce toxicity and extend their duration of action. This is most effective during infiltration anaesthesia and nerve blocks, and less effective in epidurals or spinals. Some authorities recommend that solutions containing epinephrine should never be used intrathecally. Only very small concentrations of epinephrine are required to obtain intense vasoconstriction ( $\alpha$ -adrenergic effect). The concentration is expressed as the weight of epinephrine (g) per volume of solution (mL). Commonly used concentrations range from 1 : 80 000 to 1 : 200 000.

Local anaesthetics containing vasoconstrictors must never be used around extremities (e.g. fin-



gers, toes, penis), as the vasoconstriction can cause fatal tissue ischaemia.

$$1:80000 = 1\text{g in } 80000\text{mL} = 1\text{mg in } 80\text{mL} \\ = 0.0125\text{mg/mL or } 12.5\mu\text{g/mL}$$

$$1:200000 = 1\text{g in } 200000\text{mL} = 1\text{mg in } 200\text{mL} \\ = 0.005\text{mg/mL or } 5\mu\text{g/mL}$$

The maximum safe dose in an adult is 250 $\mu$ g, that is, 20 mL of 1:80 000 or 50 mL of 1:200 000. This should be reduced by 50% in patients with ischaemic heart disease.

### Calculation of doses

For any drug it is essential that the correct dose is given and the maximum safe dose never exceeded. This can be confusing with local anaesthetic drugs as the volume containing the required dose will vary depending upon the concentration (expressed in per cent), and a range of concentrations exists for each drug. The relationship between concentration, volume and dose is given by the formula:

$$\text{Concentration (\%)} \times \text{Volume (mL)} \times 10 = \text{dose (mg)}$$

### Local anaesthetic toxicity

This is usually the result of one of the following:

- *Rapid absorption of a normally safe dose* Use of an excessively concentrated solution or injection into a vascular area results in rapid absorption. It can also occur during intravenous regional anaesthesia (IVRA—see below) if the tourniquet is released too soon or accidentally.
- *Inadvertent IV injection* Failure to aspirate prior to injection via virtually any route.
- *Administration of an overdose* Failure or error in either calculating the maximum safe dose or taking into account any pre-existing cardiac or hepatic disease.

Signs and symptoms of toxicity are due to effects on the central nervous system and the cardiovascular system. These are dependent on the plasma concentration and initially may represent either a mild toxicity or, more significantly, the early stages of a more severe reaction.

- *Mild or early:* circumoral paraesthesia, numbness of the tongue, visual disturbances, lightheaded-

ness, slurred speech, twitching, restlessness, mild hypotension and bradycardia.

- *Severe or late:* grand mal convulsions followed by coma, respiratory depression and, eventually, apnoea, cardiovascular collapse with profound hypotension and bradycardia, and ultimately, cardiac arrest.

### Management of toxicity

If a patient complains of any of the above symptoms or exhibits signs, stop giving the local anaesthetic immediately! The next steps consist of:

- *Airway* Maintain using basic techniques. Tracheal intubation will be needed if the protective reflexes are absent to protect against aspiration.
  - *Breathing* Give oxygen (100%) with support of ventilation if inadequate.
  - *Circulation* Raise the patient's legs to encourage venous return and start an IV infusion of crystalloid or colloid. Treat a bradycardia with IV atropine. If no major pulse is palpable, start external cardiac compression. If inotropes and vasopressors are required, invasive monitoring will be needed and this should be performed on the intensive care unit.
  - *Convulsions* These must be treated early. Diazepam 5–10 mg intravenously can be used initially but this may cause significant respiratory depression. If the convulsions do not respond or they recur, then seek assistance.
- Because of the risk of an inadvertent overdose of a local anaesthetic drug, they should only be given where full facilities for monitoring and resuscitation are immediately available. In this way the patient will recover without any permanent sequelae.

### The role of local and regional anaesthesia

Regional anaesthesia is not just an answer to the problem of anaesthesia in patients regarded as not well enough for general anaesthesia. The decision to use any of these techniques should be based on the advantages offered to both the patient and surgeon. The following are some of the considerations taken into account.

- Analgesia or anaesthesia is provided predominantly in the area required, thereby avoiding the systemic effects of drugs.
- In patients with chronic respiratory disease, spontaneous ventilation can be preserved and respiratory depressant drugs avoided.
- There is generally less disturbance of the control of coexisting systemic disease requiring medical therapy, for example diabetes mellitus.
- The airway reflexes are preserved and in a patient with a full stomach, particularly due to delayed gastric emptying (e.g. pregnancy), the risk of aspiration is reduced.
- Central neural blockade may improve access and facilitate surgery, for example by causing contraction of the bowel or by providing profound muscle relaxation.
- Blood loss can be reduced with controlled hypotension.
- There is a considerable reduction in the equipment required and the cost of anaesthesia. This may be important in underdeveloped areas.
- When used in conjunction with general anaesthesia, only sufficient anaesthetic (inhalational or IV) is required to maintain unconsciousness, with analgesia and muscle relaxation provided by the regional technique.
- Some techniques can be continued postoperatively to provide pain relief, for example an epidural.
- Complications after major surgery, particularly orthopaedic surgery, are significantly reduced.

A patient should never be forced to accept a local or regional technique. Initial objections and fears are best alleviated, and usually overcome, by explanation of the advantages and reassurance.

Whenever a local or regional anaesthetic technique is used, facilities for resuscitation must always be immediately available in order that allergic reactions and toxicity can be dealt with effectively. At a minimum this will include the following:

- Equipment to maintain and secure the airway, give oxygen and provide ventilation.

- Intravenous cannulae and a range of fluids.
- Drugs, including epinephrine, atropine, vaso-pressors and anticonvulsants.
- Suction.
- A surface for the patient that is capable of being tipped head-down.

### Local and regional anaesthetic techniques

Local anaesthetics can be used:

- topically to a mucous membrane, for example the eye or urethra;
- for subcutaneous infiltration;
- intravenously after the application of a tourniquet (IVRA);
- directly around nerves, for example the brachial plexus;
- in the extradural space ('epidural anaesthesia');
- in the subarachnoid space ('spinal anaesthesia').

The latter two techniques are more correctly called 'central neural blockade'; however, the term 'spinal anaesthesia' is commonly used when local anaesthetic is injected into the subarachnoid space and it is in this context that it will be used. The following is a brief introduction to some of the more popular regional anaesthetic techniques; those who require more detail should consult the texts in Further reading.

#### Infiltration analgesia (Fig. 2.23)

Lignocaine 0.5% is used for short procedures, for example suturing a wound, and 0.5% bupivacaine for pain relief from a surgical incision. A solution containing epinephrine can be used if a large dose or a prolonged effect is required, providing that tissues around end arteries are avoided. Infiltration analgesia is not instantaneous and lack of patience is the commonest reason for failure. The technique used is as follows:

- Calculate the maximum volume of drug that can be used.
- Clean the skin surrounding the wound with an appropriate solution and allow to dry.
- Insert the needle subcutaneously, avoiding any obvious blood vessels.

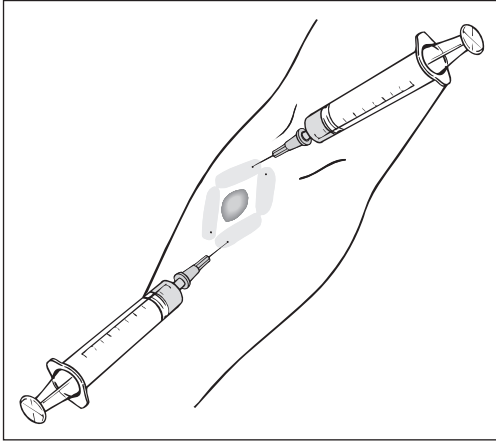

**Figure 2.23** Infiltration with local anaesthetic.

- Aspirate to ensure that the tip of the needle does not lie in a blood vessel.
- Inject the local anaesthetic in a constant flow as the needle is withdrawn. Too-rapid injection will cause pain.
- Second and subsequent punctures should be made through an area of skin already anaesthetized.

When suturing, the needle is inserted into an area of intact skin at one end of the wound and advanced parallel to the wound, and local anaesthetic is injected as described. In a clean wound, local anaesthetic can be injected directly into the exposed wound edge. This technique can be also used at the end of surgery to help reduce wound pain postoperatively.

### IVRA, Bier's block

Local anaesthetic is injected into the veins of an exsanguinated limb and retained by using an arterial tourniquet. Anaesthesia is produced in 10–15 mins and the duration is limited by discomfort caused by the tourniquet. Sensation returns soon after release of the tourniquet. This is a useful technique for surgery of the distal upper limb. Correct functioning of the tourniquet is essential otherwise there is the risk of the patient being given the

equivalent of a massive intravenous injection. Contraindications are relatively few but include patients with impaired peripheral circulation or sickle-cell disease.

### Brachial plexus block

The nerves of the brachial plexus can be anaesthetized by injecting the local anaesthetic drug either above the level of the clavicle (supraclavicular approach) or where they enter the arm through the axilla along with the axillary artery and vein (axillary approach). A nerve stimulator is frequently used to locate the nerves more precisely. All of the drugs in Table 2.15 can be used. These techniques can be used for a wide range of surgical procedures below the elbow and will frequently provide good analgesia in the immediate postoperative period. As the block may last several hours, it is important to warn both the surgeon and patient of this.

### Epidural anaesthesia

Epidural (extradural) anaesthesia involves the deposition of a local anaesthetic drug into the potential space *outside* the dura (Fig. 2.24a). This space extends from the craniocervical junction at C1 to the sacrococcygeal membrane, and anaesthesia can theoretically be safely instituted at any level in between. In practice, an epidural is sited adjacent to the nerve roots that supply the surgical site; that is, the lumbar region is used for pelvic and lower limb surgery and the thoracic region for abdominal surgery. A single injection of local anaesthetic can be given, but more commonly a catheter is inserted into the epidural space and either repeated injections or a constant infusion of a local anaesthetic drug is used.

To aid identification of the epidural space, a technique termed 'loss of resistance' is used. The (Tuohy) needle is advanced until its tip is embedded within the ligamentum flavum (yellow ligament). This blocks the tip and causes marked resistance to attempted injection of either air or saline from a syringe attached to the needle. As the needle is advanced further, the ligament is pierced,

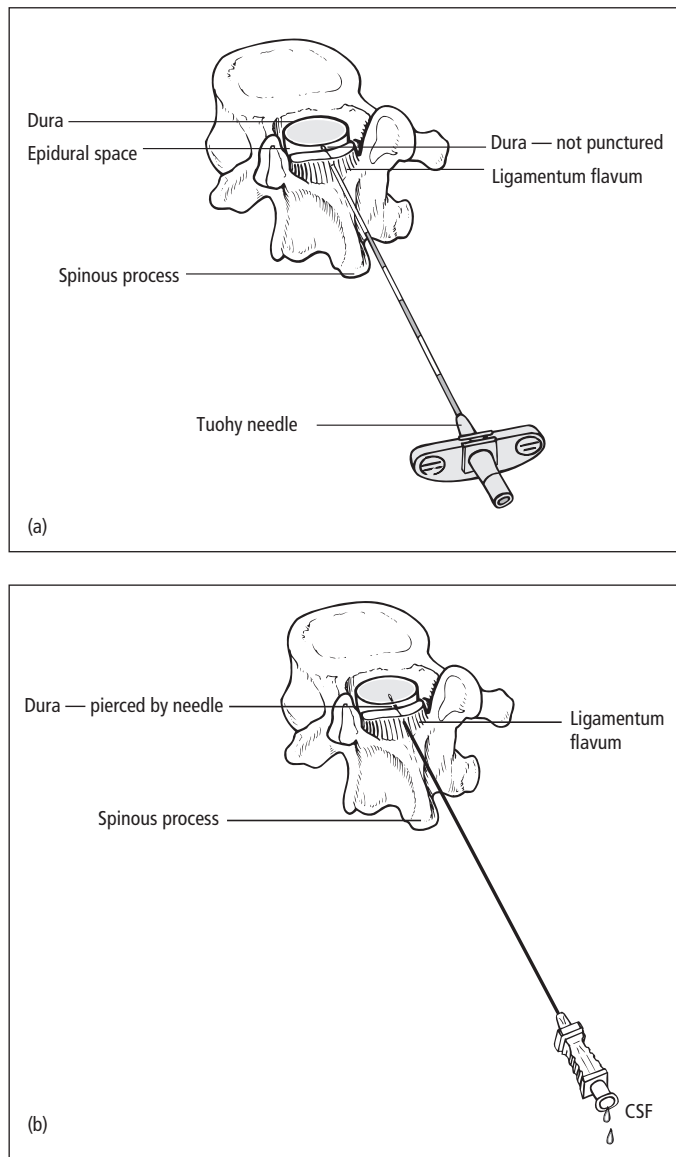

**Figure 2.24** (a) Placement of needle tip for epidural anaesthesia. (b) Placement of needle tip for spinal (intrathecal) anaesthesia. From Gwinnutt CL *Clinical Anaesthesia*. Oxford: Blackwell Science, 1996.

resistance disappears dramatically and air or saline is injected easily.

A plastic catheter is then inserted into the epidural space via the needle. The catheter is marked at 5 cm intervals to 20 cm and at 1 cm intervals between 5 and 15 cm. If the depth of the epidural space is noted, this allows the length of catheter in the space to be determined.

Varying concentrations of local anaesthetics are used depending on what effect is required. For example, bupivacaine 0.5–0.75% will be needed for surgical anaesthesia with muscle relaxation, but only 0.1–0.2% for postoperative analgesia. Local anaesthetic will spread from the level of injection both up and down the epidural space. The extent of anaesthesia is determined by:

- The spinal level of insertion of the epidural. For a given volume, spread is greater in the thoracic region than in the lumbar region.
- The volume of local anaesthetic injected.
- Gravity: tipping the patient head-down encourages spread cranially, while head-up tends to limit spread.

The spread of anaesthesia is described with reference to the limits of the dermatomes affected; for example: the inguinal ligament, T12; the umbilicus, T10; and the nipples, T4. An opioid is often given with the local anaesthetic to improve the quality and duration of analgesia, for example fentanyl 50µg. For details of infusions of local anaesthetics and opioids for postoperative analgesia, see page 87.

### Spinal anaesthesia

Spinal (intrathecal) anaesthesia results from the injection of a local anaesthetic drug directly into the cerebrospinal fluid (CSF), within the subarachnoid space (Fig. 2.24b). The spinal needle can only be inserted below the second lumbar and above the first sacral vertebrae; the upper limit is determined by the termination of the spinal cord, and the lower limit by the fact that the sacral vertebrae are fused and access becomes virtually impossible. A single injection of local anaesthetic is usually used, thereby limiting the duration of the technique.

A fine, 22–29 gauge needle with a ‘pencil point’ or tapered point (for example Whitacre or Sprotte needle) is used (Fig. 2.25). The small diameter and shape are an attempt to reduce the incidence of postdural puncture headache (see below). To aid passage of this needle through the skin and interspinous ligament, a short, wide-bore needle is introduced initially and the spinal needle passed through its lumen.

Factors influencing the spread of the local anaesthetic drug within the CSF, and hence the extent of anaesthesia, include:

- Use of hyperbaric solutions (i.e. its specific gravity is greater than that of CSF), for example ‘heavy’ bupivacaine (0.5%). This is achieved by the addition of 8% dextrose. Posture is then used to control spread.



**Figure 2.25** Photomicrograph showing shape of bevel needle (top) and ‘pencil point’ needle (below). From Jones MJ, Selby IR, Gwinnutt CL & Hughes DG. Technical note: the influence of using an atraumatic needle on the incidence of post-myelography headache. *British Journal of Radiology* 1994; 67: 396–98.

- Positioning of the patient either during or after the injection. Maintenance of the sitting position after injection results in a block of the low lumbar and sacral nerves. In the supine position, the block will extend to the thoracic nerves around T5–6, the point of maximum backwards curve (kyphosis) of the thoracic spine. Further extension can be obtained with a head-down tilt.
- Increasing the dose (volume and/or concentration) of local anaesthetic drug.
- The higher the placement of the spinal anaesthetic in the lumbar region, the higher the level of block obtained.

Small doses of an opioid, for example morphine 0.1–0.25 mg, may be injected with the local anaesthetic. This extends the duration of analgesia for up to 24 h postoperatively.

### Monitoring during local and regional anaesthesia

During epidural and spinal anaesthesia, the guidelines on monitoring (see page 49) should be followed. A conscious patient is not an excuse for inadequate monitoring! Particular attention must be paid to the cardiovascular system as a result of the profound effects these techniques can have. Maintenance of verbal contact with the patient is useful as it gives an indication of cerebral perfu-

**Table 2.16** Incidence of common complications with spinal anaesthesia

• Hypotension	33%
• Nausea	18%
• Bradycardia	13%
• Vomiting	7%
• Dysrhythmias	2%

sion. Early signs of inadequate cardiac output are complaints of nausea and faintness, and subsequent vomiting. The first indication of extensive spread of anaesthesia may be a complaint of difficulty with breathing or numbness in the fingers. Clearly, these valuable signs and symptoms will be lost if the patient is heavily sedated.

### Complications of central neural blockade

These are usually mild and rarely cause any lasting morbidity (Table 2.16). Those commonly seen intraoperatively are due predominantly to the effects of the local anaesthetic. Their management is covered below. Complications seen in patients receiving epidural analgesia postoperatively are covered on page 87.

### Hypotension and bradycardia

Anaesthesia of the lumbar and thoracic nerves causes progressive sympathetic block, a reduction in the peripheral resistance and venous return to the heart and fall in cardiac output. If the block extends cranially beyond T5, the cardioaccelerator nerves are also blocked, and the unopposed vagal tone results in a bradycardia. Small falls in blood pressure are tolerated and may be helpful in reducing blood loss. If the blood pressure falls >25% of resting value, or the patient becomes symptomatic (see below), treatment consists of:

- oxygen via a facemask;
- IV fluids (crystalloids or colloids) to increase venous return;
- vasopressors to counteract the vasodilatation, either ephedrine, an  $\alpha$ - and  $\beta$ -agonist (3 mg IV) or metaraminol, an  $\alpha$ -agonist (0.25 mg IV);
- atropine 0.5 mg IV for a bradycardia.

### Nausea and vomiting

These are most often the first indications of hypotension and cerebral hypoxia, but can also result from vagal stimulation during upper abdominal surgery. Any hypotension or hypoxia is corrected as described above. If due to surgery, try to reduce the degree of manipulation. If this is not possible then it may be necessary to convert to general anaesthesia. Atropine 0.3–0.6 mg is frequently effective, particularly if there is a bradycardia. Antiemetics can be tried (e.g. metoclopramide 10 mg intravenously), but this must not be at the expense of the above.

### Postdural puncture headache

Caused by a persistent leak of CSF from the needle hole in the lumbar dura. The incidence is greatest with large holes, that is, when a hole is made accidentally with a Tuohy needle, and least after spinal anaesthesia using fine needles (e.g. 26 gauge) with a pencil or tapered point (<1%). Patients usually complain of a headache that is frontal or occipital, postural, worse when standing and exacerbated by straining. The majority will resolve spontaneously. Persistent headaches can be relieved (>90%) by injecting 20–30 mL of the patient's own venous blood into the epidural space (epidural blood patch) under strict aseptic conditions.

### Regional anaesthesia, awake or after induction of anaesthesia?

Major nerve blocks and epidural anaesthesia are often combined with general anaesthesia to reduce the amount and number of systemic drugs given and to provide postoperative analgesia. Claimed advantages of performing the block with the patient awake:

- the block can be checked before surgery commences to ensure it works satisfactorily;
- the risk of nerve injury is reduced as the patient will complain if the needle touches a nerve;
- the patient can co-operate with positioning.

Claimed advantages of performing the block after induction of anaesthesia:

- it is more pleasant for the patient, with no discomfort during insertion of the needle;
- there is no risk of the patient suddenly moving;
- it allows easier positioning of patients in pain, for example due to fractures;
- if the needle hits the nerve then the damage has already been done.

Fortunately, in experienced hands with either technique, the risk of nerve injury resulting in permanent sequelae is very rare. However, all patients who have a regional technique should be assessed to ensure that there is full recovery of normal function.

### Contraindications to epidural and spinal anaesthesia

**Hypovolaemia** Either as a result of blood loss or dehydration. Such patients are likely to experience severe falls in cardiac output as compensatory vasoconstriction is lost.

**A low, fixed cardiac output** As seen with severe aortic or mitral stenosis. The reduced venous return further reduces cardiac output, jeopardizing perfusion of vital organs.

**Local skin sepsis** Risk of introducing infection.

**Coagulopathy** Either as a result of a bleeding diathesis (e.g. haemophilia) or therapeutic anticoagulation. This risks causing an epidural haematoma. There may also be a very small risk in patients taking aspirin and associated drugs which reduce platelet activity. Where heparins are used perioperatively to reduce the risk of deep venous thrombosis, these may be started after the insertion of the epidural or spinal.

**Raised intracranial pressure** Risk of precipitating coning.

**Known allergy to amide local anaesthetic drugs.**

**A patient who is totally uncooperative.**

**Concurrent disease of the CNS** Some would caution against the use of these techniques for fear of being blamed for any subsequent deterioration.

**Previous spinal surgery or has abnormal spinal anatomy** Although not an absolute contraindication, epidural or spinal anaesthesia may be technically difficult.

### Further reading

- Aitkenhead A, Rowbotham DJ, Smith G (eds). *Textbook of anaesthesia*, 4th edn. Edinburgh: Churchill Livingstone, 2001.
- Al-Shaikh B, Stacey S. *Essentials of anaesthetic equipment*, 2nd edn. Edinburgh: Churchill Livingstone, 2001.
- British Medical Association and the Royal Pharmaceutical Society of Great Britain. *British National Formulary (BNF)*. London: British Medical Association and the Royal Pharmaceutical Society of Great Britain. (Current issue available at BNF website: <http://www.bnf.org/>)
- Gan TJ, Meyer T, Apfel CC *et al.*, and Department of Anesthesiology, Duke University Medical Center. Consensus guidelines for managing postoperative nausea and vomiting. *Anesthesia and Analgesia* 2003; **97**: 62–71.
- Gwinnutt C, Driscoll P (eds). *Trauma resuscitation: the team approach*, 2nd edn. Oxford: Bios Scientific, 2003.
- Gosling P. Salt of the earth or a drop in the ocean? A pathophysiological approach to fluid resuscitation. *Emergency Medicine Journal* 2003; **20**: 306–15.
- Wildsmith JAW, Armitage EN (eds). *Principles and practice of regional anaesthesia*, 2nd edn. Edinburgh: Churchill Livingstone, 1993.
- Yentis SM, Hirsch NP, Smith GB. *Anaesthesia and intensive care A to Z: an encyclopaedia of principles and practice*. Edinburgh: Butterworth Heinemann, 2003.

### Useful websites

- [http://www.nice.org.uk/pdf/](http://www.nice.org.uk/pdf/Ultrasound_49_GUIDANCE.pdf)  
 Ultrasound\_49\_GUIDANCE.pdf  
 [Guidance from the National Institute of Clinical Excellence (NICE) on the use of ultrasound locating devices for placing central venous catheters.]
- <http://www.aagbi.org/>  
 [The Association of Anaesthetists of Great Britain & Ireland.]

## Chapter 2 Anaesthesia

<http://www.rcoa.ac.uk/>

[The Royal College of Anaesthetists.]

*These two sites are a must if you want to have the latest national UK guidance on anaesthetic practice.*

[www.theairwaysite.com](http://www.theairwaysite.com)

[This site is aimed at emergency physicians and orientated to American practice. It does, however, contain some useful information.]

[www.lmaco.com/](http://www.lmaco.com/)

[The laryngeal mask airway company website, which has instruction manuals for all the variations in current use.]

<http://gasnet.med.yale.edu/>

[The best anaesthesia site on the Web, with free sign-on, and a virtual textbook of anaesthesia that includes a good section on airway management.]

<http://www.capnography.com/index.html>

[This is an excellent site if you want to know more about capnography. Very detailed, so be warned.]

<http://www.jr2.ox.ac.uk/bandolier/booth/painpag/>

[The Oxford Pain site. Good for the latest evidence-based reviews in pain.]

<http://www.mhra.gov.uk/>

[Medicines and Healthcare products Regulatory Agency. This agency ensures that medicines, healthcare products and medical equipment meet appropriate standards of safety, quality, performance and effectiveness, and are used safely. Site contains latest drug and device hazards.]

[http://www.aagbi.org/pdf/blood\\_tran.pdf](http://www.aagbi.org/pdf/blood_tran.pdf)

[Association of anaesthetists guidelines on blood transfusion, 2001.]

<http://www.shotuk.org/>

[Serious Hazards of Transfusion (SHOT). Contains latest UK data.]

<http://www.nysora.com/>

[The best regional anaesthesia site.]



## Chapter 3

# Postanaesthesia care

### The recovery area

The vast majority of patients recover from anaesthesia and surgery uneventfully, but a small and unpredictable number suffer complications. It is now accepted that all patients recovering from anaesthesia should be nursed in an area with appropriate facilities to deal with any of the problems that may arise, and by trained staff. Most patients will recover on a trolley capable of being tipped head-down. Patients who have undergone prolonged surgery, or where a prolonged stay is expected, may be recovered on their beds to minimize the number of transfers. Each patient should be cared for in a dedicated area equipped with:

- oxygen supply plus appropriate circuits for administration;
- suction;
- ECG monitoring device;
- pulse oximeter;
- non-invasive blood pressure monitor.

In addition the following must be available immediately:

- *Airway equipment* Oral and nasal airways, a range of endotracheal tubes, laryngoscopes, a bronchoscope and the instruments to perform a cricothyroidotomy and tracheostomy.
- *Breathing and ventilation equipment* Self-inflating bag-valve-masks, a mechanical ventilator and a chest drain set.

- *Circulation equipment* A defibrillator, drugs for cardiopulmonary resuscitation, a range of IV solutions, pressure infusers and devices for IV access.
- *Drugs* For resuscitation and anaesthesia.
- *Monitoring equipment* Transducers and a monitor capable of displaying two or three pressure waveforms, end-tidal carbon dioxide monitor and thermometer.

### Discharge of the patient

The anaesthetist's responsibility to the patient does not end with termination of the anaesthetic. Although care is handed over to the recovery staff (nurse or equivalent), the ultimate responsibility remains with the anaesthetist until discharge from the recovery area. If there are inadequate numbers of recovery staff to care for a newly admitted patient, the anaesthetist should adopt this role.

A patient who cannot maintain his/her own airway should never be left alone.

The length of time any patient spends in recovery will depend upon a variety of factors, including length and type of surgery, anaesthetic technique and the occurrence of any complications. Most units have a policy determining the minimum length of stay, which is usually around 30mins, and agreed discharge criteria (Table 3.1).

**Table 3.1** Minimum criteria for discharge from recovery area

- Fully conscious and able to maintain own airway (although patient may still be 'sleepy')
- Adequate breathing
- Stable cardiovascular system, with minimal bleeding from the surgical site
- Adequate pain relief
- Warm

## Complications and their management

### Hypoxaemia

This is the most important respiratory complication after anaesthesia and surgery. It may start at recovery and in some patients persist for 3 days or more after surgery. The presence of cyanosis is very insensitive and when detectable the arterial  $P_{O_2}$  will be  $<8$  kPa (55 mmHg), a saturation of 85%. The advent of pulse oximetry has had a major impact on the prevention of hypoxaemia and should be used routinely in all patients. If hypoxaemia is severe, persistent or when there is any doubt, arterial blood gas analysis should be performed. Hypoxaemia can be caused by a number of factors, either alone or in combination:

- alveolar hypoventilation;
- ventilation and perfusion mismatch within the lungs;
- diffusion hypoxia;
- pulmonary diffusion defects;
- a reduced inspired oxygen concentration.

### Alveolar hypoventilation

This is the commonest cause of hypoxaemia and results in insufficient influx of oxygen into the alveoli to replace that taken up by the blood. As a result, alveolar  $P_{O_2}$  ( $PA_{O_2}$ ) and arterial  $P_{O_2}$  ( $Pa_{O_2}$ ) fall. In most patients, increasing their inspired oxygen concentration will restore alveolar and arterial  $P_{O_2}$ . Eventually a point is reached where there is only ventilation of 'dead space', that is, the volume

of the airways that plays no part in gas exchange. No oxygen reaches the alveoli irrespective of the inspired oxygen concentration and profound hypoxaemia will follow. Hypoventilation is always accompanied by hypercapnia, as there is an inverse relationship between arterial carbon dioxide ( $Paco_2$ ) and alveolar ventilation. Common causes of hypoventilation include:

- *Obstruction of the airway* Most often due to the tongue. Consider vomit, blood or swelling (e.g. post-thyroid surgery). Partial obstruction causes noisy breathing; in complete obstruction there is little noise despite vigorous efforts. There may be a characteristic 'see-saw' or paradoxical pattern of ventilation. A tracheal tug may be seen. It is prevented by recovering patients in the lateral position, particularly those recovering from surgery where there is a risk of bleeding into the airway (e.g. ear, nose and throat (ENT) surgery), or regurgitation (bowel obstruction or a history of reflux). If it is not possible to turn the patient (e.g. after a hip replacement), perform a chin lift or jaw thrust (see page 100). An oropharyngeal or nasopharyngeal airway may be required to help maintain the airway (see page 18).

No patient should be handed to the care of the recovery nurse with noisy respiration of unknown cause.

- *Central respiratory depression* The residual effects of anaesthetic drugs decrease the ventilatory response to hypoxia and hypercarbia and also reduce the level of consciousness. Support ventilation until effects have worn off or reversed. Opioid analgesics (in excess) cause respiratory depression and reduce the level of consciousness. If severe, the administration of the specific antagonist naloxone may be required (see page 39).

- *Hypothermia* Reduces ventilation but, in the absence of any contributing factors, it is usually adequate for the body's needs.

- *Cerebral haemorrhage or ischaemia* May cause direct damage to the respiratory centre or, more commonly, a deeply unconscious patient unable to maintain a patent airway.

- *Impaired mechanics of ventilation* Pain, particularly after upper abdominal or thoracic surgery, prevents coughing, leading to sputum retention and atelectasis. Provide adequate analgesia (consider central neural block). Residual neuromuscular blockade is suggested by unsustained, jerky movements with rapid, shallow breathing in a hypertensive, tachycardic patient. For test to confirm the diagnosis see page 35. The patient should be given oxygen, reassured, sat upright to improve the efficiency of ventilation, and a (further) dose of neostigmine and an anticholinergic given.
- *Pneumothorax or haemothorax* Prevents ventilation of the underlying lung. Will require insertion of chest drain.
- *Diaphragmatic splinting* Abdominal distension and obesity push the diaphragm into the thorax and increase the work of breathing. Such patients are greatly helped by being sat up.

### Ventilation and perfusion mismatch within the lungs

Normally, ventilation of the alveoli (V) and perfusion with blood (Q) are well matched ( $V/Q = 1$ ) to ensure that the haemoglobin in blood leaving the lungs is saturated with oxygen. During anaesthesia and the recovery period, this process is disturbed (ventilation/perfusion (V/Q) mismatch). Areas develop where:

- *Perfusion exceeds ventilation* ( $V/Q < 1$ ): this results in haemoglobin with a reduced oxygen content.
- *Ventilation exceeds perfusion* ( $V/Q > 1$ ): this can be considered wasted ventilation. Only a small additional volume of oxygen is taken up as the haemoglobin is already almost fully saturated (98%).

In the most extreme situation, there is perfusion of areas of the lung but no ventilation ( $V/Q = 0$ ). Blood leaving these areas remains 'venous' and is often referred to as 'shunted blood'. This is then mixed with oxygenated blood leaving ventilated areas of the lungs. The net result is:

- Blood perfusing alveoli ventilated with air has an oxygen content of approximately 20 mL/100 mL of blood.
- Blood perfusing unventilated alveoli remains

venous, with an oxygen content of 15 mL/100 mL of blood.

- The final oxygen content of blood leaving the lungs will be dependent on the relative proportions of shunted blood and non-shunted blood.

For an equivalent blood flow, areas of  $V/Q < 1$  decrease oxygen content more than increasing the oxygen concentration in areas of  $V/Q > 1$  increases content.

The aetiology of V/Q mismatch is multifactorial but the following are recognized as being of importance:

- Mechanical ventilation reduces cardiac output. This reduces perfusion of non-dependent areas of the lungs, whilst ventilation is maintained. This is worst in the lateral position, when the upper lung is better ventilated and the lower lung better perfused.
- A reduced functional residual capacity (FRC). In supine, anaesthetized patients, particularly those over 50 years of age, the FRC falls below their closing capacity—the lung volume below which some airways close and distal alveoli are no longer ventilated. Eventually, areas of atelectasis develop, mainly in dependent areas of the lung that are perfused but not ventilated.
- Pain restricts breathing and coughing, leading to poor ventilation of the lung bases, sputum retention, basal atelectasis and, ultimately, infection. This is more prevalent in the following circumstances:
  - smokers;
  - obesity;
  - pre-existing lung disease;
  - elderly;
  - after upper gastrointestinal or thoracic surgery;
  - 3 days after surgery.

The effects of small areas of V/Q mismatch can be corrected by increasing the inspired oxygen concentration. However, because of the disproportionate effect of areas  $V/Q < 1$ , once more than 30% of the pulmonary blood flow is passing through such areas, even breathing 100% oxygen will not

**Table 3.2** Effect of alveolar oxygen concentration on oxygen content of blood

	Alveolar oxygen concentration (%)	Haemoglobin saturation (%)	Oxygen content (mL/100 mL blood)
Alveoli containing air	21	97	20
Alveoli containing oxygen	100	100	21
Non-ventilated alveoli	Very low	75	15

eliminate hypoxaemia. The oxygen content of the pulmonary blood flow through areas ventilated with 100% oxygen will only increase by 1 mL/100 mL of blood (21 mL/100 mL of blood, Table 3.2), insufficient to offset the lack from the areas of low V/Q.

### Diffusion hypoxia

Nitrous oxide absorbed during anaesthesia has to be excreted during recovery. As it is very insoluble in blood, it rapidly diffuses down a concentration gradient into the alveoli, where it reduces the partial pressure of oxygen in the alveoli, making the patient hypoxaemic. This can be treated by giving oxygen via a facemask to increase the inspired oxygen concentration (see below).

### Pulmonary diffusion defects

Any chronic condition causing thickening of the alveolar membrane, for example fibrosing alveolitis, impairs transfer of oxygen into the blood. In the recovery period it may occur secondary to the development of pulmonary oedema following fluid overload or impaired left ventricular function. It should be treated by first administering oxygen to increase the partial pressure of oxygen in the alveoli and then by management of any underlying cause.

### A reduced inspired oxygen concentration

As the inspired oxygen concentration is a prime determinant of the amount of oxygen in the alveoli, reducing this will lead to hypoxaemia. There are no circumstances where it is appropriate to administer less than 21% oxygen.

### Management of hypoxaemia

All patients should be given oxygen in the immediate postoperative period to:

- counter the effects of diffusion hypoxia when nitrous oxide has been used;
- compensate for any hypoventilation;
- compensate for V/Q mismatch;
- meet the increased oxygen demand when shivering.

Patients who continue to hypoventilate, have persistent V/Q mismatch, are obese, anaemic or have ischaemic heart disease, will require additional oxygen for an extended period of time. This is best determined either by arterial blood gas analysis or by using a pulse oximeter.

### Devices used for delivery of oxygen

#### Variable-performance devices: masks or nasal cannulae

These are adequate for the majority of patients recovering from anaesthesia and surgery. The precise concentration of oxygen inspired by the patient is unknown as it is dependent upon the patient's respiratory pattern and the flow of oxygen used (usually 2–12 L/min). The inspired gas consists of a mixture of:

- oxygen flowing into the mask;
- oxygen that has accumulated under the mask during the expiratory pause;
- alveolar gas from the previous breath which has collected under the mask;
- air entrained during peak inspiratory flow from the holes in the side of the mask and from leaks between the mask and face.

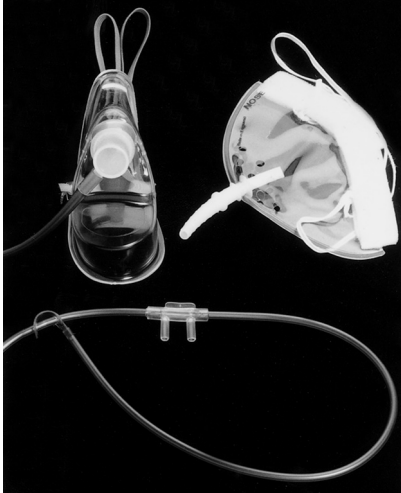

**Fig. 3.1** Hudson mask (top left), MC mask (top right) and nasal catheters (bottom).

Examples of this type of device are Hudson and MC masks (Fig. 3.1). As a guide, they increase the inspired oxygen concentration to 25–60% with oxygen flows of 2–12L/min.

Patients unable to tolerate a facemask who can nose breathe may find either a single foam-tipped catheter or double catheters, placed just inside the vestibule of the nose, more comfortable (see Fig. 3.1). Lower flows of oxygen are used, 2–4L/min increasing the inspired oxygen concentration to 25–40%.

If higher inspired oxygen concentrations are needed in a spontaneously breathing patient, a Hudson mask with a reservoir can be used (see Fig. 3.2). A one-way valve diverts the oxygen flow into the reservoir during expiration. During inspiration, the contents of the reservoir, along with the high flow of oxygen (12–15L/min), result in minimal entrainment of air, raising the inspired concentration to ≈85%. An inspired oxygen concentration of 100% can only be achieved by using either an anaesthetic system with a close-fitting facemask or a self-inflating bag with reservoir and non-rebreathing valve and an oxygen flow of 12–15L/min.



**Fig. 3.2** Hudson mask with reservoir and high airflow oxygen enrichment (HAFOE; Venturi) mask.

### Fixed-performance devices

These are used when it is important to deliver a precise concentration of oxygen, unaffected by the patient's ventilatory pattern. These masks work on the principle of high airflow oxygen enrichment (HAFOE). Oxygen is fed into a Venturi that entrains a much greater but constant flow of air. The total flow into the mask may be as high as 45L/min. The high gas flow has two effects: it meets the patient's peak inspiratory flow, reducing entrainment of air, and flushes expiratory gas, reducing rebreathing. Masks deliver either a fixed concentration or have interchangeable Venturis to vary the oxygen concentration (Fig. 3.2).

The above systems all deliver dry gas to the patient that may cause crusting or thickening of secretions and difficulty with clearance. For prolonged use, a HAFOE system should be used with a humidifier.

### Hypotension

This can be due to a variety of factors, alone or in combination, that reduce the cardiac output, the systemic vascular resistance or both (see also page 96):

- hypovolaemia;
- reduced myocardial contractility;

- vasodilatation;
- cardiac arrhythmias.

## Hypovolaemia

This is the commonest cause of hypotension after anaesthesia and surgery. Although intraoperative blood loss is usually obvious, continued bleeding, especially in the absence of surgical drains, may not be. Fluid loss may also occur as a result of tissue damage leading to oedema, or from evaporation during prolonged surgery on body cavities, for example the abdomen or thorax (see below). The diagnosis can be confirmed by finding:

- Reduced peripheral perfusion; cold clammy skin or delayed capillary refill (>2s) in the absence of fear, pain and hypothermia.
- Tachycardia; a pulse rate >100 beats/min of poor volume.
- Hypotension. Initially, systolic blood pressure may be reduced minimally but the diastolic elevated as a result of compensatory vasoconstriction (narrow pulse pressure). The blood pressure must always be interpreted in conjunction with the other assessments.
- Inadequate urine output (<0.5 mL/kg/h), best measured hourly via a catheter and urometer. Consider also the following as causes of reduced urine output:
  - a blocked catheter (blood clot or lubricant);
  - hypotension;
  - hypoxia;
  - renal damage intraoperatively (e.g. during aortic aneurysm surgery).

The commonest cause of oliguria is hypovolaemia; anuria is usually due to a blocked catheter.

The extent to which these changes occur will depend primarily upon the degree of hypovolaemia. A tachycardia may not be seen in the patient taking beta blockers and up to 15% of the blood volume may be lost without detectable signs in a fit, young patient. An arterial blood sample should be analysed; a metabolic acidosis is usually found after a period of poor tissue perfusion.

## Management (see also page 97)

- Ensure adequate oxygenation and ventilation.
- Intravenous fluid, either crystalloid or colloid, should be given, using a pressure infusor to speed administration.
- Consider cross-matching blood if not already done.
- Stop any external haemorrhage with direct pressure.
- Get surgical assistance if internal haemorrhage suspected.

Monitoring of the patient's central venous pressure (CVP) may be indicated if cardiac function is in question. In the presence of significant hypovolaemia do not waste time inserting a CVP line for venous access alone. The trend of the patient's acid-base status is a useful indicator of therapeutic success.

## Reduced myocardial contractility

The commonest cause is ischaemic heart disease, causing any degree of left ventricular failure. The diagnosis should be considered on finding:

- poor peripheral circulation;
- tachycardia;
- tachypnoea;
- distended neck veins;
- basal crepitations on auscultation of the lungs;
- wheeze with a productive cough;
- a triple rhythm on auscultation of the heart.

It is not uncommon to mistake this condition for hypovolaemia based on the first three findings. A chest X-ray is usually diagnostic.

## Management

- Sit the patient upright.
- Give 100% oxygen.
- Monitor the ECG, blood pressure and peripheral oxygen saturation.

If the diagnosis is unclear, a fluid challenge (maximum 5 mL/kg) can be given and the response observed; an improvement in the circulatory status suggests hypovolaemia. Where there is no doubt about the diagnosis, fluids can be restricted initially and a diuretic (e.g. frusemide 20–40 mg) given intravenously. Trends in the CVP can be

monitored as a guide to therapy. Patients with ventricular failure are best cared for in a critical care area. If there is acute myocardial infarction, contractility may only improve with the use of inotropes in conjunction with vasodilators, and this is best undertaken on the intensive care unit (ICU) (see page 121). Unfortunately thrombolysis is contraindicated after surgery.

### Vasodilatation

This is common during spinal or epidural anaesthesia (see page 67). Another example is following prostate surgery under spinal anaesthesia. As the legs are taken down from the lithotomy position, vasodilatation in the lower limbs is unmasked, and as the patient is moved to the recovery area he becomes profoundly hypotensive.

The development of septic shock may present initially as peripheral vasodilatation, hypotension and tachycardia in the absence of blood loss. The patient may be pyrexial and if the cardiac output is measured, it is usually elevated. Gradually, vasoconstriction ensues along with a fall in cardiac output. The diagnosis should be suspected in any patient who has had surgery associated with a septic focus, for example free infection in the peritoneal cavity or where there is infection in the genitourinary tract. This usually presents several hours after the patient has left the recovery area, often during the night following daytime surgery. The causative micro-organism is often a Gram-negative bacterium.

### Management

Hypotension secondary to regional anaesthesia is corrected by the administration of fluids (crystalloid, colloid), the use of vasopressors (e.g. ephedrine), or a combination of both. Oxygen should always be given. The combination of hypovolaemia and vasodilatation will cause profound hypotension. Patients developing septic shock require early diagnosis, invasive monitoring and circulatory support in a critical care area. Antibiotic therapy should be guided by a microbiologist.

### Cardiac arrhythmias

Occur more frequently in the presence of:

- hypoxaemia;
- hypovolaemia;
- hypercarbia;
- hypothermia;
- sepsis;
- pre-existing ischaemic heart disease;
- electrolyte abnormalities;
- hypo/hyperkalaemia, hypocalcaemia, hypomagnesaemia;
- acid-base disturbances;
- inotropes, antiarrhythmics, bronchodilators;
- antidepressants in overdose.

Tachycardias result in insufficient time for ventricular filling, thereby reducing cardiac output, while bradycardias reduce the heart rate below the point where no further increase in ventricular filling can occur to maintain cardiac output.

Coronary artery flow is dependent on diastolic pressure and time. Hypotension and tachycardia are therefore particularly dangerous.

### Management

Correction of the underlying problem will result in spontaneous resolution of most arrhythmias. Specific intervention is required if there is a significant reduction in cardiac output and hypotension. The Resuscitation Council (UK) publishes guidelines that are regularly updated.

- *Sinus tachycardia* (>100 beats/min) The commonest arrhythmia after anaesthesia and surgery, usually as a result of pain or hypovolaemia. If there is associated pyrexia, it may be an early indication of sepsis. Treatment consists of oxygen, analgesia and adequate fluid replacement. If the tachycardia persists, then providing there is no contraindication a small dose of a beta blocker may be given intravenously whilst monitoring the ECG. Rarely, the development of an unexplained tachycardia after anaesthesia may be the first sign of malignant hyperpyrexia (see page 98).
- *Supraventricular tachycardia* The most common is atrial fibrillation usually secondary to ischaemic



heart disease or the presence of sepsis. Treatment will depend on the rate and reduction in cardiac output:

- heart rate 100–150/min with critical perfusion will require cardioversion followed by IV amiodarone 300mg over 1 h;
- heart rate <100/min with good perfusion, consider amiodarone 300mg IV over 1 h.
- *Sinus bradycardia* (<60 beats/min) Usually the result of:
  - an inadequate dose of an anticholinergic (e.g. glycopyrrolate) given with neostigmine to reverse neuromuscular block;
  - excessive suction to clear pharyngeal or tracheal secretions;
  - traction on the viscera during surgery;
  - excessive high spread of spinal or epidural anaesthesia;
  - the development of acute inferior myocardial infarction;
  - excessive beta-blockade preoperatively or intraoperatively.

Treatment should consist of removing any provoking stimuli and administering oxygen. If symptomatic, atropine 0.5mg intravenously may be required.

## Hypertension

This is most common in patients with pre-existing hypertension. It may be exacerbated or caused by:

- Pain
- Hypoxaemia
- Hypercarbia
- Confusion or delirium
- Hypothermia.

A coexisting tachycardia is particularly dangerous in the presence of ischaemic heart disease as this may cause an acute myocardial infarction. If the blood pressure remains elevated after correcting the above, a vasodilator or beta blocker may be necessary. Senior help should be sought.

## Postoperative nausea and vomiting (PONV)

This occurs in up to 80% of patients following anaesthesia and surgery. A variety of factors have been identified which increase the incidence:

- Age and sex: more common in young women and children.
- Site of surgery: abdominal, middle ear or the posterior cranial fossa.
- Giving opioid analgesics pre-, intra- and post-operatively.
- Anaesthetic drugs: etomidate, nitrous oxide.
- Gastric dilatation, caused by manual ventilation with a bag and mask without a clear airway.
- Hypotension associated with epidural or spinal anaesthesia.
- Patients prone to travel sickness.

Patients identified as being at risk of PONV should be given an anti-emetic before emergence from anaesthesia. Failure of treatment may be addressed in the recovery area by giving a second or third drug from different classes of compound.

## Drugs used to treat nausea and vomiting

Before resorting to the administration of drugs to treat nausea and vomiting, it is essential to make sure that the patient is not hypoxaemic or hypotensive.

- *Antihistamines* Cyclizine. Adults 50mg intramuscularly, up to 6 hourly. Also has anticholinergic actions; may cause a tachycardia when given IV.
- *5-HT<sub>3</sub> (hydroxytryptamine) antagonists* Ondansetron (Zofran). Adults 4–8mg intravenously or orally, 8 hourly. Has both central and peripheral actions; in the gut it blocks 5-HT<sub>3</sub> receptors in the mucosal vagal afferents. It does not cause dystonic movements.
- *Dopamine antagonists* Metoclopramide (Maxolon). Adults 10mg intravenously, intramuscularly or orally, 6 hourly. Although a specific anti-emetic, minimal effect against PONV. Not related to the major tranquillizers and has no sedative or antihistamine effects. Has an effect at the



chemoreceptor trigger zone and increases gastric motility. An alternative is domperidone (Motilium) 10mg orally.

- *Phenothiazine derivatives* Prochlorperazine (Stemetil). Adults 12.5mg intramuscularly 6 hourly or 15–30mg orally, daily in divided doses. May cause hypotension due to alpha-blockade. Some have antihistamine activity and may cause dystonic muscle movements.
- *Anticholinergic drugs* Atropine and hyoscine; the latter is available as a transdermal patch. Severe side-effects, particularly dry mouth and blurred vision.
- *Steroids* Dexamethasone 8mg IV may be useful in resistant cases.

### Postoperative intravenous fluid therapy

Oral intake should be encouraged as not all patients require routine IV fluids after anaesthesia and surgery. For those that do, the volume and type of fluid will be determined by a variety of factors, including:

- the site of surgery;
- the extent of tissue damage;
- blood loss during and after surgery;
- any delay in starting to drink;
- continuing losses from the gastrointestinal tract.

A wide range of fluids are available (see page 59), and for each patient the type and volume will be dependent upon the calculated maintenance requirements of water and electrolytes plus the replacement of any abnormal losses. This is complemented by clinical evaluation of the patient to ensure that they are adequately hydrated, as assessed by degree of thirst, moisture of mucous membranes, blood pressure, pulse, peripheral circulation and an adequate urine output. In complex cases, monitoring the trend of the CVP may also prove useful.

### Minor surgery

Following minor surgical procedures (i.e. taking less than 30mins, with minimal blood loss and tis-

sue trauma), most patients start drinking within 1–2h of surgery and IV fluid is not required. If a patient has failed to drink within 4–6h (usually as a result of nausea and vomiting), consideration should be given to commencing IV fluids. Providing that the volume of vomit is not excessive, only maintenance fluids are required. These are calculated at 1.5 mL/kg/h, but must take into account the accrued deficit.

For example, a 70kg patient starved from 0800 to 1400, who is still unable to take fluids by mouth at 1800 will require:

1.5mL/kg/h to make up the deficit from 0800 until 1800  
 $= 1.5 \times 70 \text{ (kg)} \times 10 \text{ (h)} \approx 1000\text{mL};$   
 1.5mL/kg/h from 1800 until 0800 the next morning:  
 $= 1.5 \times 70 \text{ (kg)} \times 14 \text{ (h)} \approx 1400\text{mL}.$   
 The total IV fluid requirement = 2400ml in the next 14h.

An appropriate rate for the IV fluid would be:

- 1000mL over the first 4h;
- 1000mL over the following 6h;
- 500mL over the last 4h.

This should contain the daily requirement of  $\text{Na}^{++}$  1–1.5mmol/kg and could be given either as:

$2 \times 1000\text{mL } 5\% \text{ glucose and } 500\text{mL } 0.9\% \text{ (normal) saline; or}$

$2 \times 1000\text{mL } 4\% \text{ glucose}/0.18\% \text{ saline, and } 500\text{mL } 4\% \text{ glucose}/0.18\% \text{ saline.}$

The patient should be reviewed at 0800 with regard to further management.

### Major surgery

Following major surgery, postoperative fluid balance is more complex. Assuming that appropriate volumes of water, electrolytes and blood have been given during the operation, then postoperatively the fluid and electrolyte requirements will depend upon:

- the volume needed for ongoing maintenance, which will be increased if the patient is pyrexial;

- replacement of continuing losses from the gastrointestinal tract, for example via a nasogastric tube;
- any continued bleeding;
- rewarming of cold peripheries causing vasodilatation.

The patient who has undergone major surgery will require close monitoring to ensure that sufficient volumes of the correct fluid are administered. A standard postoperative regimen for the first 24 h postoperatively might therefore consist of:

- 1.5 mL/kg/h water, increased by 10% for each °C if the patient is pyrexial;
- sodium, 1 mmol/kg;
- replacement of measured gastrointestinal losses with an equal volume of Hartmann's solution;
- replacement of blood loss of <500 mL with either:
  - Hartmann's solution (three times the volume of blood lost will be needed as it is distributed throughout the extracellular fluid (ECF)); or
  - colloid, the same volume as the blood loss;
  - blood loss >1000 mL will require transfusion with stored blood.

It is essential that the patient is reviewed at the end of the day as described above to ensure that the volumes and type of fluid prescribed are adequate for the patient's needs.

On the second and subsequent days, the same basic principles are used. In addition:

- The fluid balance of the previous 24 h must be checked.
- Ensure that all sources of fluid loss are recorded.
- The patient's serum electrolytes must be checked to ensure adequate replacement.
- The urine output for the previous 6 and 24 h should be noted; if decreasing, consider other causes of fluid loss, for example increasing pyrexia, development of an ileus.
- Potassium will be required (in addition to sodium) at the rate of 1 mmol/kg per 24 h.

If surgery is associated with significant tissue trauma (e.g. total hip replacement, major gastrointestinal surgery), then there will be continued losses into the tissues, which have the same effect as any other form of fluid loss and are often referred to as 'third space losses'. Such volumes are difficult to

measure and usually become evident as a result of the above regimen failing to keep the patient adequately hydrated. This is usually seen as thirst, a dry mouth, cool peripheries with empty superficial veins, hypotension, tachycardia and a decrease in the urine output to less than 0.5 mL/kg/h. An additional 1 L of Hartmann's solution per 24 h may need to be added to the above regimen to account for such losses and adjusted according to the patient's response. These losses may continue for up to 48 h after surgery and sufficient extra volumes of fluid should be administered to maintain hydration and an adequate circulating volume. Where large volumes of fluid are required and/or there is underlying heart disease, then the CVP should be measured and the trend noted (see page 52) and serum electrolytes monitored twice daily.

### The stress response

Following major surgery and trauma, various neuroendocrine responses result in an increased secretion of a variety of hormones. Antidiuretic hormone (ADH) secretion is maximal during surgery and may remain elevated for several days. The effect of this is to increase water absorption by the kidneys and reduce urine output. Aldosterone secretion is raised secondary to increased cortisol levels and activation of the renin-angiotensin system. This results in sodium retention and increased urinary excretion of potassium. Despite this retention of water and sodium, it is important that fluid input is not restricted in these patients, as the continued losses identified above more than offset the volume retained.

After 2–3 days, hormone levels return to normal and this is followed by an increase in the volume of urine passed, which may be augmented by loss of fluid as tissue oedema resolves.

### Postoperative analgesia

After injury, acute pain limits activity until healing has taken place. Modern surgical treatment restores function more rapidly, a process facilitated by the elimination of postoperative pain. A good example is the internal fixation of fractures, fol-

lowed by potent analgesia allowing early mobilization. Ineffective treatment of postoperative pain not only delays this process, but also has other important consequences:

- Physical immobility:
  - reduced cough, sputum retention and pneumonia;
  - muscle wasting, skin breakdown and cardiovascular deconditioning;
  - thromboembolic disease—deep venous thrombosis and pulmonary embolus;
  - delayed bone and soft tissue healing.
- Psychological reaction:
  - reluctance to undergo further, necessary surgical procedures.
- Economic costs:
  - prolonged hospital stay, increased medical complications;
  - increased time away from normal occupations.
- Development of chronic pain syndromes.

Sometimes pain is a useful aid to diagnosis and must be recognized and acted upon, for example:

- pain due to ischaemia from tissue swelling, haematoma formation restricting the circulation causing a compartment syndrome or by dressings becoming too tight;
- pain of infection from cellulitis, peritonitis or pneumonia;
- referred visceral pain in myocardial infarction (arm or neck) or pancreatitis (to the back).

Any patient who complains of pain that unexpectedly increases in severity, changes in nature or site, or is of new onset should be examined to identify the cause rather than simply be prescribed analgesia.

### Factors affecting the experience of pain

Pain and the patient's response to it are very variable and should be understood against the background of the individual's previous personal experiences and expectations rather than compared with the norm.

- Anxiety heightens the experience of pain. The preoperative visit by the anaesthetist plays a significant role in allaying anxiety by explaining

what to expect postoperatively, what types of analgesia are available and also by allowing patients to explore their concerns.

- Patients who have a pre-existing chronic pain problem are vulnerable to suffering with additional acute pain. Their nervous systems can be considered to be sensitized to pain and will react more strongly to noxious stimuli. Bad previous pain experiences in hospital or anticipation of severe pain for another reason suggest that extra effort will be required to control the pain.
- Older patients tend to require lower doses of analgesics as a result of changes in drug distribution, metabolism, excretion and coexisting disease. Prescribing should take these factors into account rather than using them as an excuse for inadequate analgesia. There is no difference between the pains suffered by the different sexes having the same operation.
- Upper abdominal and thoracic surgery cause the most severe pain of the longest duration, control of which is important because of the detrimental effects on ventilation. Pain following surgery on the body wall or periphery of limbs is less severe and for a shorter duration.

### Management of postoperative pain

This can be divided into a number of steps:

- assessment of pain;
- analgesic drugs used;
- techniques of administration;
- difficult pain problems.

### Assessment of acute pain

Regular measurement of pain means that it is more difficult to ignore and the efficacy of interventions can be assessed. There are a variety of methods of assessing pain; Table 3.3 shows a simple, practical system that is easily administered and understood by patients. The numeric score is to facilitate recording and allows trends to be identified. Pain must be assessed with appropriate activity for the stage of recovery; for example, 5 days after a hip joint replacement a patient would not be expected to have pain while lying in bed, but adequate

**Table 3.3** A simple practical scoring system for acute pain

Pain score	Staff view	Patient's view	Action
0	None	Insignificant or no pain	Consider reducing dose or changing to weaker analgesic, e.g. morphine to NSAID plus paracetamol
1	Mild	In pain, but expected and tolerable; no reason to seek (additional) treatment	Continue current therapy, review regularly
2	Moderate	Unpleasant situation; treatment desirable but not necessarily at the expense of severe treatment side-effects	Continue current therapy, consider additional regular simple analgesia, e.g. paracetamol and/or NSAID
3	Severe	Intolerable situation—will consider even unpleasant treatments to reduce pain	Increase dose of opioid, or start opioid; consider alternative technique, e.g. epidural

analgesia should allow mobilization with only mild to insignificant pain.

### Analgesic drugs used postoperatively (Fig. 3.3)

The most commonly used drugs are opioids and NSAIDs.

#### Opioids

The pharmacology of opioid drugs and their side-effects are covered on page 37. In the UK, morphine is most commonly used to control severe postoperative pain on surgical units, and diamorphine (heroin) on medical wards, for example coronary care units, mainly for historical reasons. There are few pharmacological differences between these two drugs. Morphine can be given by several routes (Table 3.4). One of the principal metabolites, morphine-6-glucuronide (M6G), has potent opioid effects and may accumulate and cause toxicity in patients with renal failure, particularly the elderly. Fentanyl and oxycodone have less active metabolites than morphine and so may be more suitable for these patients.

For most painful clinical conditions there will be a blood level of opioid that provides useful analgesia, that is, a reduction in pain level. The dose required to achieve this may vary enormously between patients as a result of differences in:

- pharmacodynamics: the effect of the drug on the body (via the receptors);

- pharmacokinetics: how the body distributes, metabolizes and eliminates the drug;
- the nature of the stimulus;
- the psychological reaction to the situation.

The biggest step forward in the treatment of acute pain with opioids has been the recognition that individual requirements are very variable and the dose needs to be titrated for each patient:

- There is no minimum or maximum dose.
- Even with best practice some pain will remain.
- Minimum levels of monitoring and intervention are necessary for safe, effective use.
- Additional methods of analgesia should be considered if opioid requirements are high.

#### Overdose

Profound respiratory depression and coma due to opioids must be treated using the ABC principles described elsewhere (page 99). Having created a patent airway and supported ventilation using a bag-valve-mask with supplementary oxygen, the effects of the opioid can be pharmacologically reversed (antagonized) using naloxone. 0.4 mg is diluted to 5 mL with 0.9% saline and given in incremental doses of 1 mL IV (adult dosing). Analgesia will also be reversed, and careful thought must be given to continuing analgesia. HDU care is usually advisable in this situation.

#### Long-term complications of opioids

Adequate treatment of acute pain with opioids is not associated with dependency.

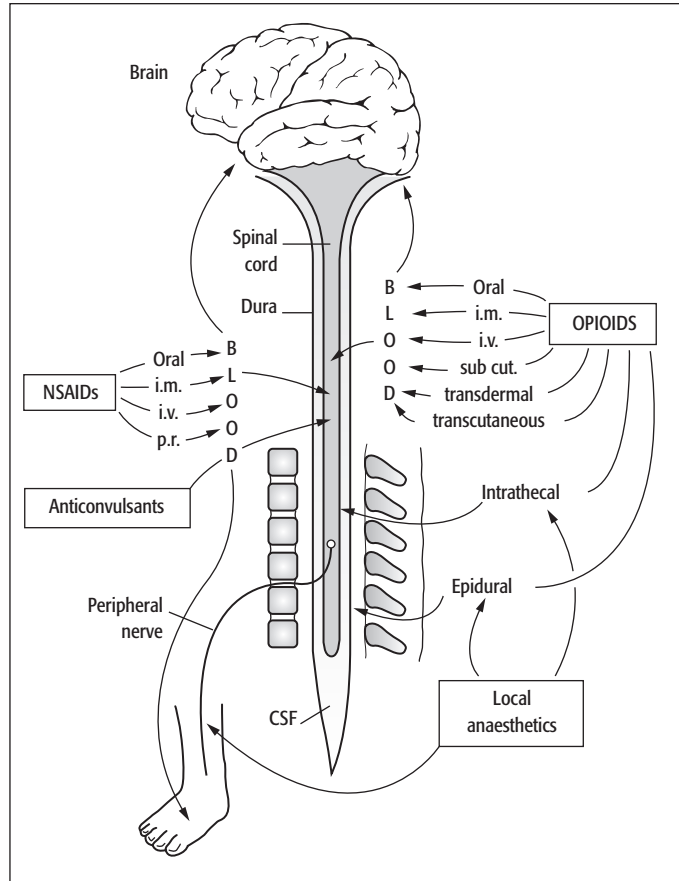

**Fig. 3.3** Sites of action of analgesic drugs.

#### Less potent opioid agonists

- *Codeine (3-methyl morphine)* Well absorbed orally, dose 30–60 mg 6 hourly (can be given intramuscularly but never intravenously). Available in a range of tablets, often combined with paracetamol, for example co-codamol (8 mg codeine, 500 mg paracetamol). Exerts its effect by a small amount (10%) being metabolized to morphine in the liver. Some patients lack the necessary enzyme and therefore get no effect from codeine.
- *Tramadol* Similar potency to codeine and used for mild to moderate pain (see page 37). Neither is a controlled drug and so are more easily accessible.

#### Non-steroidal anti-inflammatory drugs (NSAIDs)

The pharmacology of these drugs has been covered on page 40.

- *Paracetamol* An analgesic and antipyretic with little anti-inflammatory action, but usually classified with NSAIDs. Inhibits prostaglandin synthesis, mainly in the CNS. It is used to treat mild to moderate pain. Well absorbed orally, causing little irritation of the gastrointestinal tract. Widely used orally in a dose of 1 g 4–6 hourly, maximum 4 g/day. Often incorporated into compound preparations with aspirin or codeine. An intravenous preparation is available containing 10 mg/mL, in 100 mL vials (1 g). This can be infused over 15 mins and is effective in 5–10 mins. The dose is the same as for the oral preparation. It is the safest of all

**Table 3.4** Administration of morphine

Oral	<p>Immediate release (IR) tablets or liquid</p> <ul style="list-style-type: none"> <li>• Absorption and effect within minutes</li> <li>• Usual adult dose 20 mg hourly prn</li> <li>• Less in elderly, more if opioid tolerant</li> <li>• Providing the gut is working, useful even after major surgery</li> <li>• Usually used for acute pain where the opioid requirement is unknown or changing rapidly</li> </ul> <p>Modified release (MR) tablets, capsules or granules</p> <ul style="list-style-type: none"> <li>• Dose released over either 12 or 24 h</li> <li>• Avoids frequent dosing with immediate release preparations</li> <li>• Useful when opioid requirement is prolonged and also for gradually weaning down the dose at the end of treatment</li> </ul> <p>The two formulations are usually used together to provide a steady background level of analgesia (MR) with additional breakthrough doses (IR) as required</p> <p><i>It is important that everybody understands the difference between MR and IR forms of morphine</i></p>
Intravenous	<p>Morphine 10 or 20 mg diluted to 1 mg/mL with 0.9% sodium chloride can be given:</p> <ul style="list-style-type: none"> <li>• In increments initially of 1–3 mg at 3 min intervals; effective dose may range from 1 to 50 mg or more (the latter in opioid-tolerant patients)</li> <li>• Via patient controlled analgesia device (see below)</li> <li>• As a continuous infusion. Useful where patient cooperation is limited, e.g. in elderly patients or intensive care units. Problems occur in predicting the correct infusion rate, given the variability of dose requirement between patients</li> </ul> <p>Very close supervision is required to avoid underinfusion (pain) or overinfusion (toxicity)</p> <p>This method can be used to replace high doses of oral opioids during the perioperative period</p> <p><i>The intravenous dose of morphine is about one-third of the oral dose</i></p>
Intramuscular	<ul style="list-style-type: none"> <li>• A predetermined dose (e.g. morphine 10 mg) at fixed minimum intervals, e.g. hourly</li> <li>• Delayed and variable rate of effect</li> <li>• Precise titration is difficult with repeated cycles of pain and relief</li> <li>• Does not require complex equipment or a co-operative patient</li> <li>• Widely available</li> <li>• Intermittent injections through an indwelling cannula may be more acceptable to staff and patients</li> </ul>

analgesics but patients may need reassurance that regular dosing of 1 g every 6 h is not associated with hepatic toxicity. A summary of the use of these drugs is given in Table 3.5.

### **Analgesic techniques used postoperatively**

#### **Patient-controlled analgesia (PCA)**

- A microprocessor-controlled syringe pump capable of being programmed is used to deliver a predetermined dose of a drug intravenously.

- Activation is by the patient depressing a switch that is designed to prevent accidental triggering (hence ‘patient-controlled’).
- There may be a background, low-dose, continuous infusion.

To prevent the administration of an overdose:

- The dose and any background infusion is preset (usually by a doctor).
- After successful administration of a dose, a subsequent dose cannot be administered for a preset period, the ‘lockout period’.
- The total quantity of drug given over a predetermined period can be limited.

**Table 3.5** Non-steroidal anti-inflammatory drugs (NSAIDs)

Route given	Non-specific (COX-1 + 2)	COX-2 specific	CNS effect only
Oral	Ibuprofen 200–400 mg 8-hourly	Rofecoxib 50 mg once daily	Paracetamol 1 g 6-hourly
Intravenous	Ketorolac 10–30 mg 6-hourly, max 90 mg/24 h	Paracoxib 40 mg 12-hourly	Paracetamol 1 g equivalent
<i>Effects</i>			
Anti-inflammatory	Yes	Yes	No
Analgesic (central)	Yes	Yes	Yes
<i>Side-effects</i>			
Reduced renal blood flow	Yes	Probably	No
Gastric ulceration	Yes	Unlikely	No
Anti-platelet	Yes	Unlikely	No
Delay bone healing	Possible	Unlikely	No

- Typical settings for an adult using morphine delivered by a PCA device might be:

- bolus dose: 1 mg;
- lockout interval: 5 mins.

**Effective PCA requires:**

- That the patient be briefed by the anaesthetist and/or nursing staff preoperatively and, if possible, be shown the device to be used.

- A loading dose of analgesic, usually intravenously before starting. Failure to do this will result in the patient being unable to get sufficient analgesia from the PCA device and the system will fail.

- A dedicated IV cannula or non-return valve on an IV infusion to prevent accumulation of the drug and failure of analgesia.

Observation and recording of the patient's pain score, sedation score and respiratory rate to ensure success. Any patient whose respiratory rate is less than 8 breaths/min and sedation score is 2 or 3 should be treated as described in Table 3.6.

**Advantages of PCA**

- Greater flexibility; analgesia matched to the patient's perception of the pain.
- Reduced workload for the nursing staff.
- Elimination of painful IM injections.

**Table 3.6** Management of overdose with patient-controlled analgesia (PCA)

<ul style="list-style-type: none"> <li>• Stop the PCA</li> <li>• Give oxygen via a mask</li> <li>• Call for assistance</li> <li>• Consider giving naloxone (as described on page 82)</li> <li>• If the patient is apnoeic, commence ventilation using a self-inflating bag-valve-mask device</li> </ul>
---

- Intravenous administration with greater certainty of adequate plasma levels.

**Disadvantages**

- Equipment is expensive to purchase and maintain.
- Requires patient comprehension of the system.
- Patient must be physically able to trigger the device.
- The elderly are often reluctant to use a PCA device.
- The potential for overdose if the device is incorrectly programmed.

As pain subsides the PCA can be discontinued, and oral analgesics can be used. The first dose should be given 1 h prior to discontinuing PCA, to ensure continuity of analgesia.

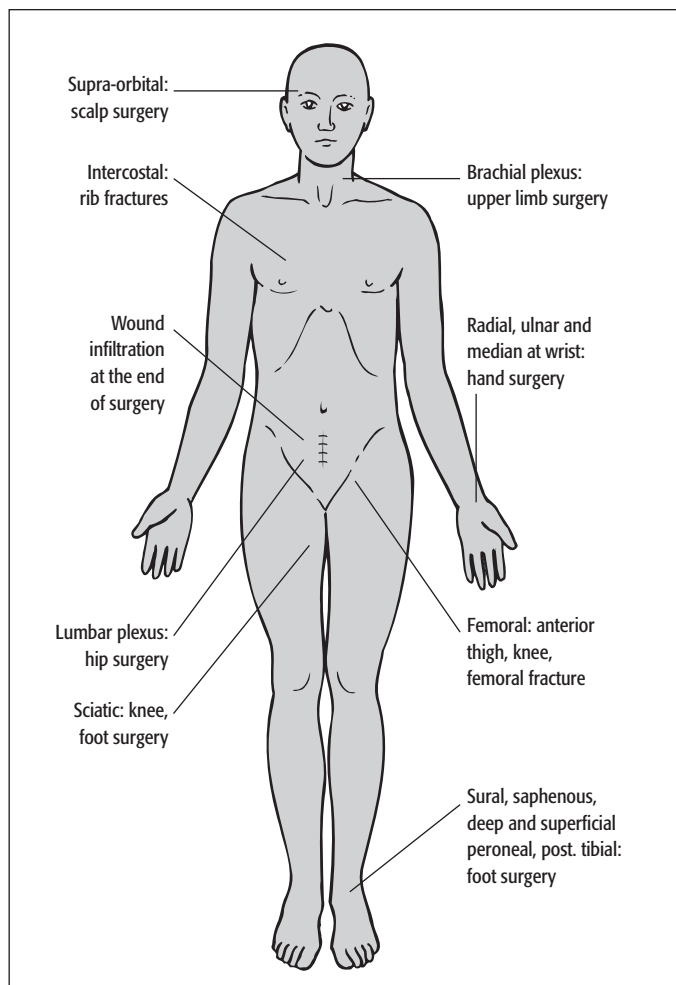

**Fig. 3.4** Some commonly used nerve blocks.

### Regional analgesic techniques (Fig. 3.4)

- *Peripheral nerve blocks* Used mainly for pain relief after upper or lower limb surgery. A single injection of local anaesthetic, usually bupivacaine, results in 6–12h of pain relief. An infusion of local anaesthetic via a catheter inserted close to the nerve may enable the block to be continued for several days. An alternative effective form of analgesia must be prescribed for when the local anaesthetic is discontinued to prevent the patient being in severe pain.
- *Epidural analgesia* (see also page 65) Infusions of a local anaesthetic into the epidural space, either

alone or in combination with opioids, act on the transiting nerve roots and the dorsal horn of the spinal cord, respectively, to provide dramatic relief of postoperative pain. It is essential that patients who are offered an epidural receive an explanation by the anaesthetist at the preoperative visit of what to expect postoperatively, in particular altered sensation, weakness of the lower limbs and the potential need for a urinary catheter. The epidural is often sited preoperatively and used as part of the anaesthetic technique. For upper abdominal surgery an epidural in the mid-thoracic region (T6/7) is used, while a hip operation would need a lumbar epidural (L1/2).



Different combinations of local anaesthetic and opioid infusion have been used successfully. Ideally, the concentration of local anaesthetic should block sensory nerves, leaving motor nerves relatively spared. The choice and dose of opioid should be such that the drug passes through the dura into the CSF in sufficient quantities to block the opioid receptors in the spinal cord but not spread cranially to cause respiratory depression. For example:

- bupivacaine 0.167% plus diamorphine 0.1 mg/mL;
- bupivacaine 0.125% plus fentanyl 4 µg/mL.

Epidural infusions can be used to maintain analgesia for several days. Opioid side-effects are less common and less severe than when given systemically as the dose is much less.

#### Points to note

- The infusion rate and the site of the catheter determine the spread of the solution. In the thoracic epidural space a starting infusion rate might be 4 mL/h; in the lumbar space commence at 8 mL/h.
- The efficacy of the infusion must be monitored in a similar manner as for PCA.
- If analgesia is inadequate, a 'top-up' of 3–4 mL of solution may be necessary.
- Observations of the patient's vital signs should then be made on a regular basis according to local protocol.
- In patients over the age of 60 years, the concentration of opioid is often halved.

#### Management of complications during postoperative epidural analgesia

This will depend upon whether local anaesthetics alone or in combination with opioids have been used. The complications arising as a result of the use of local anaesthetics intraoperatively are covered on page 63.

- *Hypotension* Sympathetic block causes vasodilatation and increased venous pooling. Treat acutely with IV fluid and vasopressors (e.g. ephedrine according to local policy). Prevented by ensuring the patient has an adequate fluid regimen prescribed. Patients with additional fluid losses, for

example haemorrhage, are particularly vulnerable to severe hypotension. Check the extent of the block; if extensive, reduce the rate of infusion.

- *Respiratory depression* Caused by opioid reaching the respiratory centre in the medulla. Highly lipid soluble opioids (diamorphine, fentanyl) are rapidly taken up by the spinal cord, limiting their spread and systemic absorption, and respiratory depression tends to occur early; less soluble opioids (morphine) are taken up slowly, and respiratory depression tends to occur later. A high infusion rate of either drug may also lead to respiratory depression. Prevented by regular assessment and recording of vital signs. Treat by supporting ventilation if necessary; stop the epidural infusion; give naloxone according to the severity; seek expert help.

- *Sedation* Due to opioid reaching the brain either directly via the CSF or after absorption into the systemic circulation via the epidural veins. May be secondary to hypotension and cerebral hypoxaemia. Prevent by regular assessment and recording of vital signs. Treat by stopping the infusion; if unresponsive or the level of sedation progresses, give naloxone in 0.1 mg increments intravenously; seek expert help.

- *Pruritus* Can be severe and frequently localized to the nose; may respond to antihistamines, atropine or naloxone.

- *Retention of urine* May be due to the effect of the opioid on bladder sphincter control or the local anaesthetic removing the sensation of a full bladder. More common in males, particularly if there are already symptoms of prostatism. Prevented by routine monitoring of urine output in all postoperative patients. May require short-term catheterization.

- *Numbness and weakness of the legs* Usually due to excessive rates of infusion or a too-high concentration of local anaesthetic. May lead to pressure ulcers on the patient's heels or sacrum due to lack of movement, or falls whilst mobilizing. Prevented by regular observation of effects of epidural and correct adjustment of infusion rate.

- *Vertebral canal haematoma* Can occur as a result of trauma by the needle or catheter insertion. Greater risk in patients on warfarin, heparin, NSAIDs and other antiplatelet drugs, those with a

coagulopathy or when severely haemodiluted. Rare, but consider if profound motor and sensory block far greater than anticipated.

- **Infection** Introduced via the catheter. May cause the formation of an epidural abscess and compromise of the spinal cord. Patients complain typically of increasing back pain but this may be delayed for several weeks so that the connection to the surgery and epidural may be missed.

If there is any doubt about spinal cord function the epidural infusion should be stopped and a magnetic resonance imaging (MRI) scan considered. Damage to nerves or the spinal cord during insertion of the needle and systemic toxicity of the local anaesthetic are both unusual complications.

### Intrathecal (spinal) analgesia

(see page 66)

Spinal anaesthesia is of insufficient duration to provide postoperative pain relief. However, if a small dose of opioid, for example morphine 0.1–0.25 mg, is injected along with the local anaesthetic, this may provide up to 24h of analgesia. Complications are the same as those due to opioids given epidurally, and managed in the same way.

### Other techniques

Entonox is a mixture of nitrous oxide (50%) and oxygen (50%). It is a weak analgesic with sedative properties. Useful for short-term analgesia for painful procedures, for example change of dressings. It should be avoided in patients with a pneumothorax because the nitrous oxide may diffuse into the gas-filled space, increasing the volume.

### Combining analgesic techniques

Examples of good practice are:

- bupivacaine and fentanyl in an epidural infusion;
- intravenous PCA morphine and intravenous paracetamol in the early postoperative period when nil by mouth;

- oral morphine immediate release (IR) tablets and paracetamol prescribed to be given as a spinal wears off.

### Difficult pain problems

Patients in whom there is evidence of regular opioid use preoperatively, for example drug addicts, cancer and chronic pain patients and those patients with a previous bad pain experience, will pose a particular problem postoperatively. They are best managed using a team approach that will include:

- Liaison with the Acute Pain Team to inform it of the patient's admission.
- Discussion with the anaesthetist, and surgical and nursing staff to plan perioperative care, to:
  - ensure any current opioid medication is continued on admission to prevent withdrawal;
  - understand that much larger doses of opioids than normal may be required;
  - explain that toxicity from high doses of opioid is very unlikely;
  - reassure that addiction is not a concern.
- Discussion with the patient to explain:
  - types and effectiveness of analgesic regimes available postoperatively;
  - that analgesia may not be 100% effective;
  - that long-term continuation may be necessary;
  - potential side-effects, especially if regional analgesia planned.
- Plan regular reviews during postoperative period.
- Coordination of care.

### Further reading

Bay I, Nunn JF, Prys Roberts C. Factors affecting arterial PO<sub>2</sub> during recovery from general anaesthesia. *British Journal of Anaesthesia* 1968; **40**: 398–407.

Gan TJ, Meyer T, Apfel CC *et al.*, and Department of Anesthesiology, Duke University Medical Center. Consensus guidelines for managing

postoperative nausea and vomiting. *Anesthesia and Analgesia* 2003; **97**: 62–71.

Shelly MP, Eltringham RJ. Rational fluid therapy during surgery. *British Journal of Hospital Medicine* 1988; **39**: 506–17.

Thomson AJ, Webb DJ, Maxwell SRJ, Grant IS. Oxygen therapy in acute medical care. *British Medical Journal* 2002; **324**: 1406–7.

West JB. *Respiratory physiology: the essentials*, 6th edn. Baltimore: Williams and Wilkins, 1999.

### Useful websites

<http://www.aagbi.org/pdf/Postanaes2002.pdf>  
[Immediate postanaesthetic recovery. The Association of Anaesthetists of Great Britain & Ireland. September 2002.]

[http://oac.med.jhmi.edu/res\\_phys/](http://oac.med.jhmi.edu/res_phys/)  
[The Johns Hopkins School of Medicine interactive respiratory physiology website.]  
<http://www.resus.org.uk/pages/periartst.htm>  
[Current Resuscitation Council UK guidelines on peri-arrest arrhythmias.]  
<http://www.jr2.ox.ac.uk/bandolier/booth/painpag/>  
[The Oxford Pain site. Brilliant for the latest evidence-based information on all aspects of acute pain.]  
<http://www.jr2.ox.ac.uk/bandolier/Extraforbando/APain.pdf>  
[Acute Pain. Bandolier extra. Evidence-based healthcare. February 2003.]

## Chapter 4

# Management of perioperative emergencies and cardiac arrest

Anaesthesia is extremely safe and uneventful, but occasionally problems occur in the perioperative period that may be incidental or secondary to the anaesthetic and potentially life-threatening to the patient. Whatever their nature, most difficulties can be dealt with initially using the ABC principles of resuscitation: maintain and secure the airway, ensure adequate breathing or ventilation and support the circulation. Assistance will be required frequently and should always be sought early.

### Acute severe drug reactions

Most drug reactions in anaesthesia are mild and transient, consisting mainly of localized urticaria as a result of cutaneous histamine release. The incidence of severe reactions to anaesthetic drugs is approximately 1 : 10000 drug administrations, and is more common in females. Of those reported to the Medicines Control Agency, 10% involved a fatality compared to 3.7% for drugs overall. This probably reflects the frequency with which anaesthetic drugs are given intravenously. Clinical features include (in order of frequency):

- severe hypotension;
- severe bronchospasm;
- widespread flushing;
- hypoxaemia;
- urticaria;
- angioedema, which may involve the airway;
- pruritus, nausea and vomiting.

Cardiovascular collapse is the most common and severe feature. Asthmatics often develop bronchospasm that is resistant to treatment, and any circumstance reducing the patient's catecholamine response (e.g. beta blockers, spinal anaesthesia) will increase the severity.

These events are caused by one of two things:

- *An anaphylactic reaction* This involves the liberation of histamine, 5-hydroxytryptamine (5-HT) and associated vasoactive substances from mast cells and basophils, following exposure to a foreign substance (the drug) to which the individual has become sensitized. It is usually an IgE-mediated reaction.
- *An anaphylactoid reaction* This is clinically indistinguishable from the above, but the release of histamine, etc. from mast cells is triggered by non-IgE mechanisms.

### Causes of allergic reactions

- *Anaesthetic drugs:*
  - muscle relaxants (>50%): rocuronium, suxamethonium, atracurium, vecuronium;
  - induction agents (5%): thiopentone, propofol.
- *Antibiotics* (8%):
  - penicillin (2% of patients may cross-react to modern cephalosporins).
- *Intravenous fluids:*
  - colloids (3%); haemaccel, gelofusin.
- *Latex* (17%)

## Immediate management

- Discontinue all drugs likely to have triggered the reaction.
- Call for help.
- Maintain the airway, administer 100% oxygen, elevate the patient's legs.
- Give epinephrine (adrenaline), 50–100 µg *slowly* intravenously (0.5–1 mL of 1:10000) under ECG control. If no ECG available, give 0.5 mg intramuscularly (0.5 mL of 1:1000). Give further doses according to the response.
- Ensure adequate ventilation:
  - Intubation will be required if spontaneous ventilation is inadequate or in the presence of severe bronchospasm. It may be made exceedingly difficult by the presence of severe laryngeal oedema. In these circumstances a needle cricothyroidotomy or surgical airway will be required.
- Support the circulation:
  - Start a rapid intravenous infusion of fluids 10–20 mL/kg. Crystalloids initially may be safer than colloids. In the absence of a major pulse, start cardiopulmonary resuscitation using the protocol for PEA.
- Monitoring:
  - ECG, oxygenation of the peripheral tissues (SpO<sub>2</sub>), blood pressure, end-tidal CO<sub>2</sub>. Establish an arterial line and check the blood gases. Monitor central venous pressure (CVP) and urine output to assess adequacy of circulating volume.

## Subsequent management

- *Salbutamol*: 2.5–5.0 mg nebulized or 0.25 mg IV.
- *Aminophylline*: 6 mg/kg as an infusion over 20 mins (omit if the patient is taking regular theophylline).
- *Antihistamines*: chlorpheniramine 8–16 mg slowly IV (anti-H<sub>1</sub>), ranitidine 50 mg IV (anti-H<sub>2</sub>).
- *Steroids*: hydrocortisone 500 mg or methylprednisolone 2 g IV.

As soon as possible these patients should be transferred to an intensive care unit (ICU) for further treatment and monitoring. Reactions vary in severity, can be biphasic, delayed in onset (particularly

latex sensitivity) and prolonged. An infusion of epinephrine (adrenaline) may be required. The possibility of a tension pneumothorax (secondary to barotrauma) causing hypotension must not be forgotten.

## Investigations

The most informative is measurement of plasma tryptase. A blood sample (10 mL, plain tube) should be taken immediately after treatment, approximately 1 h after the event and at 6 h. Elevated tryptase confirms anaphylactic or anaphylactoid reaction, but does not distinguish between them. Expert advice about follow-up and identification of the cause must be arranged.

Finally, record all details in the patient's notes, and do not forget to inform the patient and the patient's general practitioner of the events, both verbally and in writing. In the UK, report adverse drug events to the Medicines and Healthcare products Regulatory Agency by completing a 'yellow card'.

Generalized atopy does not help predict the risk of immunologically mediated reaction to anaesthetic drugs. A previous history of 'allergy to an anaesthetic' is cause for concern and there is a high risk of cross-reactivity between drugs of the same group. These patients must be investigated appropriately.

## Aspiration of gastric contents

The greatest risk is during induction of anaesthesia, but some patients are also at risk during extubation and recovery. Postoperative patients on the ward who have received liberal amounts of opiates for pain relief or have impaired pharyngeal reflexes may also aspirate. The incidence of complications appears to be related to both the volume (>25 mL) and pH (<2.5) of the material aspirated.

*Factors predisposing to aspiration include:*

- delayed gastric emptying;
- obstetric patients;
- drugs, especially opiates;
- trauma patients, particularly head injury;
- intestinal obstruction or peritoneal irritation;
- blood in the stomach;

- sympathetic stimulation, pain and anxiety;
- a full stomach:
  - an inadequate period of starvation;
  - distension with mask ventilation;
- a history of gastro-oesophageal reflux or a hiatus hernia;
- obesity;
- head-down position;
- presence of a bulbar palsy;
- oesophageal pouch or stricture.

*Signs suggesting aspiration include:*

- coughing during induction or recovery from anaesthesia;
- the presence of gastric contents in the pharynx at laryngoscopy or around the edge of the facemask;
- progressive hypoxia;
- bronchospasm;
- respiratory obstruction, if severe;
- occasionally, aspiration may go completely unnoticed during anaesthesia, with the development of hypoxia, hypotension and respiratory failure postoperatively.

## Management

- Maintain the airway and place the patient head-down and on his or her side, preferably the left; intubation is relatively easier on this side.
- Aspirate any material from the pharynx, preferably under direct vision (use a laryngoscope).

*(i) Neuromuscular blocking drugs not given; surgery not urgent:*

- Give 100% oxygen via a facemask.
- Allow the patient to recover, give oxygen to maintain a satisfactory  $SpO_2$ .
- Treat bronchospasm with salbutamol or aminophylline as described on page 91.
- Take a chest X-ray and organize regular physiotherapy.
- Consider monitoring on the ICU or HDU, depending on degree of aspiration.

*(ii) Neuromuscular blocking drugs not given; surgery essential:*

- Get help, empty the stomach with a nasogastric tube and instill 30 mL sodium citrate.

- After allowing the patient to recover, continue using either a regional technique or a rapid-sequence induction and intubation.
- After intubation, aspirate the tracheobronchial tree and consider bronchoscopy.
- Treat bronchospasm as above.
- Postoperatively, arrange for a chest X-ray and physiotherapy.
- Recover in the ICU or HDU with oxygen therapy.
- Postoperative ventilation may be required.

*(iii) Neuromuscular blocking drugs given:*

- Intubate with a cuffed tracheal tube to secure the airway.
- Aspirate the tracheobronchial tree before starting positive pressure ventilation.
- Consider bronchopulmonary lavage with saline.
- Treat bronchospasm as above.
- Pass a nasogastric tube and empty the stomach.
- If the patient is stable (i.e. not hypoxic or hypotensive), surgery can be continued with postoperative care as described above.

If aspiration is suspected in a patient postoperatively, treat as for (i) above.

There is no place for routine administration of large-dose steroids. Antibiotics should be given according to local protocols.

In those cases where bronchospasm is resistant to treatment or there is persistent hypoxia or hypotension, unless surgery is life-saving the patient should be transferred to the ICU for ventilation where, in addition, invasive cardiorespiratory monitoring will also be needed.

## Prevention of aspiration

A variety of methods are used, alone or in combination:

- 1** Reduction of residual gastric volume
  - An adequate period of starvation.
  - Avoid drugs that delay gastric emptying.
  - Insertion of a nasogastric tube.
  - Use of gastrokinetic drugs, for example metoclopramide.
- 2** Increase pH of gastric contents
  - Sodium citrate to neutralize gastric acid.

- H<sub>2</sub> antagonists, for example ranitidine.
- Proton pump inhibitors, for example omeprazole, rebepazole.

**3** Use of cricoid pressure  
See page 26.

## Failed intubation

The following plans concentrate on *unexpected failed intubation*. The immediate management in these circumstances will depend upon:

- ability to maintain adequate oxygenation;
- type of neuromuscular blocker used, either depolarizing or non-depolarizing;
- urgency of surgery (and the likelihood of a full stomach);
- need for intubation.

## Anaesthesia for emergency surgery

Assuming the patient has a full stomach, a rapid-sequence induction (RSI) technique of preoxygenation, cricoid pressure and suxamethonium is used to facilitate intubation:

- get help;
- maintain cricoid pressure;
- administer 100% oxygen via facemask;
- ventilate gently to minimize the risk of gastric distension, try one- or two-person technique, use oral and/or nasal airway;
- consider reducing cricoid pressure if ventilation difficult.

## Oxygenation and ventilation successful

*Surgery essential:*

- Continue anaesthesia with inhalational agent in oxygen.
- Maintain airway with LMA, Proseal LMA or Combitube.

*Surgery not essential:*

- Maintain oxygenation and allow patient to recover.
- Plan alternative technique.

*Intubation essential for surgery:*

- Allow the patient to recover, empty the stomach

via a nasogastric tube, use awake fibreoptic intubation under local anaesthesia.

*Intubation not essential for surgery:*

- Use a LMA, Proseal LMA or Combitube.
- Consider using a regional anaesthetic technique.

## Anaesthesia for elective surgery

Assume that the patient is starved, minimizing the risk of aspiration, and a non-depolarizing neuromuscular blocker given to facilitate tracheal intubation.

- Get help.
- Administer 100% oxygen via facemask.
- Ventilate gently to minimize the risk of gastric distension, try one- or two-person technique, use oral and/or nasal airway.

## Oxygenation and ventilation successful

Maintain anaesthesia with inhalational agent in oxygen.

*Intubation essential for surgery:*

- Attempt fibreoptic intubation.
- Attempt intubation using an Intubating LMA.
- Maintain anaesthesia and ventilation using an LMA or facemask until neuromuscular block can be reversed; awaken patient and plan for elective fibreoptic intubation.

*Intubation not essential for surgery:*

- Use an LMA, Proseal LMA or Combitube. Consider using a regional anaesthetic technique.

## Failed intubation, failed ventilation

Whatever the surgical urgency, if intubation fails and the patient cannot be oxygenated via a facemask, LMA or any other means:

- GET HELP.
- Perform needle cricothyroidotomy or surgical cricothyroidotomy (see page 28).
- In any situation other than surgery for life-threatening condition, maintain oxygenation and unconsciousness until neuromuscular block has worn off or is reversible.
- In life-threatening circumstances, maintain oxy-

genation, secure the airway using an alternative technique (tracheostomy, fiberoptic intubation).

Any patient whose airway has been traumatized, either as a result of repeated attempts at intubation or following surgical intervention, is at risk of developing oedema and airway obstruction at extubation. These patients should be admitted to an appropriate critical care area postoperatively and may require endoscopy prior to extubation.

Full details of the difficulties encountered and any solutions must be documented in the patient's notes. The patient must be given verbal and written details (consider 'MedicAlert' type device) and details sent to his or her GP.

### **Acute airway obstruction**

This may present in a variety of ways:

#### **Conscious patient**

- Usually distressed and unwilling to lie down.
- Marked respiratory effort, using accessory muscles (e.g. sternomastoids).
- Indrawing of intercostal and supraclavicular regions and a tracheal tug.
- Stridor. If inspiratory, consider obstruction above the larynx.
- Tachycardia and hypertension secondary to hypoxia and hypercarbia.
- The history, if available, may indicate the cause; for example inhaled foreign body, oedema (allergic reaction, inhalational injury), infection (epiglottitis), tumour or trauma.

#### **Unconscious patient**

- Usually secondary to unrelieved obstruction causing hypoxaemia and hypercarbia.
- Minimal respiratory effort.
- Paradoxical movement of the chest and abdomen (see-saw ventilation).
- Minimal or no breath sounds (silent chest).
- Hypotension, a variety of arrhythmias, cyanosed.

### **After induction of anaesthesia**

- Asymptomatic.
- Obstruction apparent on attempting manually to ventilate the patient, due to a supraglottic lesion acting as a 'ball valve'.

### **During anaesthesia**

- Mechanical obstruction of the breathing system.
- Intrinsic airway obstruction (e.g. bronchospasm).
- Extrinsic obstruction (e.g. tension pneumothorax).

### **Management**

Whatever the circumstances, the aim is to secure a patent airway to allow adequate oxygenation.

- Increase the inspired oxygen concentration to 100%.
- Get help urgently.
- If not already available, request the emergency airway equipment.

#### **In the conscious patient**

- If safe to do so, transfer rapidly to the anaesthetic room in theatre.
- If ventilation is reasonable, induce anaesthesia using an inhalational anaesthetic in oxygen. Increasing the inspired concentration too rapidly may cause coughing and worsen the obstruction.
- Gentle manual supplementation of ventilation may be possible.
- When anaesthesia is adequate perform direct laryngoscopy.
- Intubate if possible.
- If this fails, and the airway is adequate, carry out formal tracheostomy.
- If this fails, and the airway is inadequate, carry out needle cricothyroidotomy.

Under some circumstances it may be safer initially to carry out needle cricothyroidotomy under local anaesthesia to allow oxygenation before inducing anaesthesia and direct laryngoscopy.



**In the unconscious patient**

- Attempt ventilation with 100% oxygen.
- Perform direct laryngoscopy quickly, once only.

*If possible:*

- Remove any foreign bodies under direct vision using Magill's forceps.
- Pass a small-diameter (5.0mm) tracheal tube past the obstruction into the larynx.
- If this fails, proceed rapidly to either needle or surgical cricothyroidotomy.
- Once oxygenation is restored, the patient may recover consciousness rapidly. Sedation and neuromuscular blocking drugs may be required while the airway is formally assessed.

**In the anaesthetized patient**

- Attempt to ventilate with 100% oxygen.
- Perform direct laryngoscopy.
- If possible pass a small-diameter (5.0mm) tracheal tube past the obstruction into the larynx.
- If unsuccessful, proceed to cricothyroidotomy.

**Acute severe asthma**

This is characterized by any one of:

- Severe breathlessness:
  - an inability to complete a sentence in one breath;
  - a silent chest;
  - cyanosis.
- Tachypnoea: respiratory rate >25 breaths/min.
- Tachycardia: heart rate >110 beats/min.
- Peak expiratory flow (PEF) 33–50% of best or predicted.

Acute severe asthma is considered *life threatening* in a patient with any one of the following:

- feeble respiratory effort;
- PEF <33% of best or predicted;
- $SpO_2$  <92%;
- $PaO_2$  <8 kPa;
- normal  $PaCO_2$  (4.6–6.0 kPa);
- cyanosis;
- bradycardia, arrhythmias, hypotension;
- exhaustion, confusion, coma.

**Immediate management**

- High-flow oxygen.
- High-dose beta-2 agonists via oxygen driven nebulizer.
- Salbutamol 5 mg, terbutaline 10 mg.
- Ipratropium bromide, 0.5 mg via oxygen driven nebulizer.
- Prednisolone 40–50 mg orally, or hydrocortisone 100 mg IV, or both.

**Monitor**

- PEF, 15–30 min intervals.
- Pulse oximetry: maintain  $SpO_2$  > 92%.
- Arterial blood gases.
- A chest X-ray is only indicated if:
  - there is suspected pneumothorax or pneumo-mediastinum;
  - there is suspected consolidation;
  - there is failure to respond to therapy;
  - mechanical ventilation is required.

**Subsequent management**

*If the patient is improving:*

- continue oxygen therapy;
- give IV hydrocortisone 100 mg 6 hourly or 40–50 mg orally daily;
- give nebulized salbutamol and ipratropium 4–6 hourly.

*If the patient is not improving:*

- continue oxygen therapy;
- give nebulized salbutamol 5 mg more frequently, every 15–30 mins or 10 mg continuously hourly;
- continue ipratropium 0.5 mg 4–6 hourly;
- give magnesium sulphate 1.2–2.0 g IV as slow infusion over 20 mins;
- consider IV beta-2 agonist or aminophylline;
- consider need for tracheal intubation and mechanical ventilation.

*Discuss with Critical Care team if there is:*

- need for tracheal intubation and ventilatory support;
- continuing failure to respond to treatment;
- a deteriorating PEF;
- persistent or worsening hypoxia;

- hypercapnia;
- development of acidosis (fall in pH or increase in hydrogen ion concentration);
- exhaustion;
- drowsiness or confusion;
- coma;
- respiratory arrest.

## Tension pneumothorax

A pneumothorax exists when any gas accumulates in the pleural cavity. This leads to collapse of the underlying lung as a result of perfusion (Q) but no ventilation (V) ( $V/Q < 1$ ) and hypoxaemia. If the gas accumulates under pressure, then a tension pneumothorax exists. In addition to hypoxaemia, the increasing pressure causes the mediastinum to shift, impeding venous return, severely reducing the cardiac output. If unrelieved, it is rapidly followed by cardiovascular collapse and death.

### Characteristics of a tension pneumothorax

The conscious patient will be tachypnoeic and in severe respiratory distress.

In addition, and in the anaesthetized patient, signs on the affected side will include:

- reduced movement;
- hyperresonance on percussion;
- decreased air entry;
- distension of the hemithorax.

There may also be:

- surgical emphysema;
- tachycardia, hypotension;
- deviation of the trachea away from the affected side;
- distended neck veins (if the patient is not hypovolaemic);
- a gradual rise in the inflation pressure, if the patient is being ventilated, or failure to deliver a preset tidal volume.

### Causes

Puncture of the pleura lining the surface of the lung (visceral pleura). This can be due to:

- chest trauma with associated rib fractures;
- insertion of central venous line, particularly when the subclavian route is used;
- use of local anaesthetic nerve blocks, for example intercostal nerves, supraclavicular brachial plexus block;
- rupture of an emphysematous bulla.

The concurrent use of positive pressure ventilation will increase the rate at which the pressure rises as gas is forced through the defect into the pleural cavity, resulting in rapid cardiovascular collapse.

A simple pneumothorax can tension when nitrous oxide is given. The nitrous oxide diffuses into the air-filled space in a greater volume and at a rate faster than nitrogen can escape, causing expansion and a rise in the pressure.

## Management

- If using nitrous oxide, this should be discontinued.
- Increase the inspired oxygen concentration to 100%.
- Insert a 14 or 16 gauge cannula in the second intercostal space, midclavicular line (immediately above the third rib to avoid the neurovascular bundle).
- If successful, this is often accompanied by an obvious release of gas under pressure, decreased respiratory distress (or inflation pressures) and an improvement in the cardiac output.

The insertion of a cannula has the effect of converting the tension pneumothorax to a simple pneumothorax. This can then be treated by the insertion of a chest drain in the fifth intercostal space, midaxillary line on the affected side. Finally, a chest X-ray is taken.

N.B. Very rarely there may be bilateral tension pneumothoraces.

## Severe hypotension

Hypotension is a result of a reduction in either the cardiac output or the peripheral resistance, alone or in combination (blood pressure = cardiac output  $\times$  peripheral resistance). Severe hypotension may

be defined as a systolic pressure 40% less than the preoperative value.

### Reduced cardiac output

*Decreased venous return to the heart:*

- Hypovolaemia: blood loss, extracellular fluid loss (diarrhoea, vomiting).
- Position, for example head up, prone with abdominal compression.
- Mechanical obstruction impeding venous return: pulmonary embolus, tension pneumothorax, cardiac tamponade (rare).

*Decreased myocardial contractility:*

- Intravenous and inhalational anaesthetic agents.
- Ischaemic heart disease, hypoxia, hypothermia, acidosis.

*Extremes of heart rate:*

- Profound bradycardia, <40 beats/min.
- Tachycardia, >160 beats/min.

### Reduced peripheral resistance

*Anaesthetic drugs:*

- A direct action on vascular smooth muscle in the arteriolar wall, for example isoflurane.
- The release of histamine, for example atracurium.
- Reducing sympathetic tone, for example central neural block.

### Sepsis:

- Toxins released can cause failure of the precapillary sphincters, leading to widespread vasodilatation of the vascular bed.

*Spinal cord injury:*

- Injury to the cervical or upper thoracic cord causes loss of sympathetic tone to blood vessels and vasodilatation.
- If above T5, loss of cardiac sympathetic supply will result in a bradycardia.

*Miscellaneous:*

- Hypercarbia and a pyrexia will both cause vasodilatation.

Severe hypotension requiring intervention is

usually the result of a combination of the above factors; for example, vasodilatation caused by the anaesthetic drugs in a hypovolaemic patient.

### Management

Initially, time should not be spent trying to identify the cause. Treatment is symptomatic using the ABC system.

- *Airway* Clear and secure. If hypotension renders the patient unconscious, intubation will be needed to protect the airway.

- *Breathing and ventilation* Increase the inspired oxygen concentration to 100%. Support ventilation if inadequate or absent, using a facemask initially and then via a tracheal tube.

- *Circulation* If not already done, insert a short, wide-bore cannula in the most obvious peripheral vein, often in the antecubital fossa. Raise the legs to encourage venous return. Fluid, either crystalloid or colloid, should be given, using a pressure infuser to speed administration. Stop any external haemorrhage with direct pressure. Seek urgent surgical assistance if any internal haemorrhage. If a bradycardia is present (heart rate <60/min), then consider atropine 0.5–1 mg IV.

At this point, treatment should be directed towards specific causes that may be suggested by the findings on examination or by the patient's past medical history.

### Additional measures

- *Vasopressors:* for example ephedrine to counteract vasodilatation.
- *Inotropes:* for example dopamine or dobutamine to increase myocardial contractility.
- *Antiarrhythmics.*
- *A change in position or relief of a tension pneumothorax:* to allow venous return.
- *Needle pericardiocentesis:* in the very rare circumstances of cardiac tamponade.
- *Monitoring of CVP or pulmonary artery pressure:* to guide therapy in complex cases.

## Malignant hyperpyrexia (hyperthermia) (MH)

This is a rare inherited disorder of skeletal muscle metabolism. The release of abnormally high concentrations of calcium from the sarcoplasmic reticulum causes increased muscle activity and metabolism. Excess heat production causes a rise in core temperature of at least 2°C/h.

Triggered by exposure to certain anaesthetic agents:

- all the inhalational anaesthetic agents, of which halothane is the most potent;
- suxamethonium.

Associated with certain operations:

- squint surgery;
- hernia repair;
- corrective orthopaedic surgery;
- cleft palate repair.

Incidence of between 1:10000 and 1:40000 anaesthetized patients.

### Presentation

- A progressive rise in body temperature (which may go unnoticed unless the patient's temperature is being monitored).
- An unexplained tachycardia.
- An increased end-tidal CO<sub>2</sub>.
- Tachypnoea in spontaneously breathing patients.
- Muscle rigidity, despite the use of relaxants.
- Failure to relax after suxamethonium, especially persistent masseter spasm.
- Cardiac arrhythmias.
- A falling oxygen saturation and cyanosis.

Analysis of an arterial blood sample will demonstrate:

- a profound metabolic acidosis (low pH and bicarbonate);
- a low PaO<sub>2</sub> despite a high inspired oxygen concentration;
- a high PaCO<sub>2</sub>;
- hyperkalaemia;
- a coagulopathy (disseminated intravascular coagulation (DIC)).

### Immediate management

- GET HELP.
- Stop all anaesthetic agents.
- Hyperventilate with 100% oxygen.
- Change the anaesthesia machine and circuits.
- Terminate surgery as soon as practical.
- Monitor core temperature.
- Give dantrolene 1 mg/kg IV (up to 10 mg/kg may be needed, average dose 2.5–4 mg/kg).
- Start active cooling:
  - cold 0.9% saline IV;
  - expose the patient completely;
  - surface cooling—ice where vessels run close to skin, for example over axillary and femoral arteries, or by using wet sponging and fanning to encourage cooling by evaporation;
  - consider gastric or peritoneal lavage with cold saline.
- Treat acidosis with 8.4% sodium bicarbonate in 50 mmol (50 mL) IV titrated to acid–base results.
- Treat hyperkalaemia.

Transfer the patient to the ICU as soon as possible to:

- monitor temperature; may be labile for up to 48 hours;
- continue dantrolene to alleviate muscle rigidity;
- monitor urine output for myoglobin, and treating to prevent renal failure;
- treat DIC if it develops.

### Dantrolene

The specific treatment for MH. It inhibits calcium release, inhibiting excitation–contraction and preventing further muscle activity. Dantrolene is orange in colour and supplied in vials containing 20 mg (plus 3 g mannitol); it requires 60 mL water for reconstitution and is very slow to dissolve.

### Investigation of the family

Following an episode, the patient and his or her family should be referred to an MH unit for investigation of their susceptibility to MH.

## Anaesthesia for malignant hyperpyrexia-susceptible patients

- Employ a regional technique using plain bupivacaine.
- General anaesthesia:
  - use a designated vapour-free machine and new circuits and hoses;
  - propofol, thiopentone, opioids, atracurium, vecuronium, pancuronium are thought to be safe;
  - employ a total IV technique, using an infusion of propofol and remifentanyl, with oxygen-enriched air for ventilation;
  - consider pretreatment with dantrolene (orally or IV) in those who have survived a previous episode;
  - ensure that appropriate monitoring and cooling are available;
  - continue to monitor temperature and ECG postoperatively.

## Cardiac arrest

### Adult basic life support (BLS)

BLS is performed to limit hypoxic damage of the vital organs and maximize the chances of advanced life support restoring a spontaneous circulation. A sequence of actions is performed in which the airway, breathing and circulation are supported without the use of any equipment other than a simple protective shield interposed between the mouths of the rescuer and patient (e.g. Laerdal pocket mask). This is increasingly referred to as 'Layperson BLS'. The reader should consult the current Resuscitation Council (UK) guidelines, for details of the latest algorithm putting together the techniques below (see Further reading).

### Techniques used in BLS

#### Patient evaluation

This is achieved by placing one hand on the pa-

tient's forehead and shaking his or her shoulders gently with the other hand, whilst at the same time asking loudly 'Are you all right?'

The head is held stable during the assessment to guard against the possibility of aggravating an injury to the cervical spine.

Always assume the victim may be deaf; therefore ensure that he or she can see your lips move when assessing responsiveness.

#### Airway control

In most unconscious victims the airway will become obstructed at the level of the hypopharynx, as the reduced tone in muscles of the tongue, jaw and neck allows the tongue to fall against the posterior pharyngeal wall (Fig. 4.1). Correction, using the following techniques, may allow recovery without the need for further intervention.

- *Head tilt plus chin lift* (Fig. 4.2) The rescuer's hand nearest the head is placed on the forehead, gently extending the head backwards. The chin is then lifted using the index and middle fingers of the rescuer's other hand. If the mouth closes, the lower lip should be retracted downwards by the thumb.
- *Jaw thrust* (Fig. 4.3) This is used if the above technique fails to create an airway, or there is a suspicion that the cervical spine may have been injured. The patient's jaw is 'thrust' upwards (forwards) by the rescuer applying pressure behind the angles of the mandible.

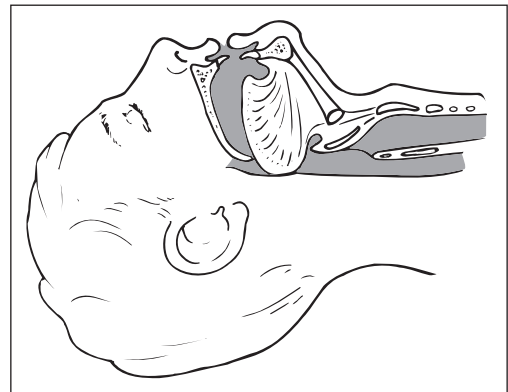

**Figure 4.1** Sagittal section of the airway, showing how the tongue contributes to obstruction.



Figure 4.2 Head tilt, chin lift.



Figure 4.4 Look, listen and feel for evidence of breathing. The hand on the chest may also detect chest movement during breathing.



Figure 4.3 Jaw thrust. Note the application of pressure behind the angles of the mandible. The tips of the thumbs can be used to open the mouth.

- *Finger sweep* The mouth must be opened and inspected, and any obvious material contributing to the obstruction removed by placing a finger in the mouth and gently sweeping from side to back, ‘hooking’ out loose material. At the same time, broken, loose or partial dentures should be removed, but well-fitting ones may be left in place (see later).

### Breathing

Checking for evidence of breathing. Maintain an airway using one of the above techniques, then (Fig. 4.4):

- *Look*: down the line of the chest to see if it is rising and falling.
- *Listen*: at the mouth and nose for breath sound, gurgling or snoring sounds.
- *Feel*: for expired air at the victim’s mouth and nose with the side of one’s cheek.

If there is no evidence of spontaneous ventilation, expired-air ventilation will be required.

### Expired-air ventilation (rescue breathing or mouth-to-mouth ventilation)

- There must be a clear path, with no leaks, between the rescuer’s lungs and the victim’s lungs.
- Keep the victim’s airway patent by performing a head tilt, while using the index finger and thumb

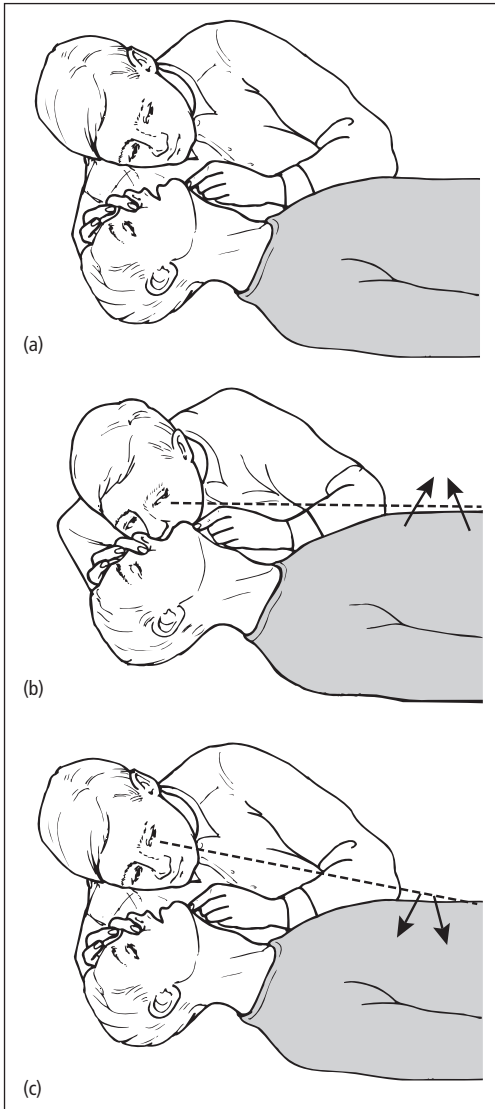

**Figure 4.5** (a–c) Expired air (mouth-to-mouth) ventilation.

of the same hand to pinch the nose to prevent leaks.

- The fingers of the lower hand are then used to perform a chin lift, and if necessary open the victim's mouth (Fig. 4.5a).
- The rescuer takes a deep breath in and makes a seal with their lips around the victim's mouth.

Well-fitting dentures are often usefully left *in situ* as they help maintain the contour of the mouth and make it easier to create a good seal.

- The rescuer then breathes out into the victim's mouth for 1.5–2s.
- At the same time look down the victim's chest: each breath should be sufficient to make the chest rise clearly (Fig. 4.5b).
- Maintaining the head tilt/chin lift, the rescuer now moves away from the mouth to allow passive exhalation for 2–4s, watching to ensure the chest falls (Fig. 4.5c).

Each complete cycle of expired-air ventilation should take 5–6s, thereby allowing 10–12 breaths/min.

#### **Mouth-to-nose ventilation**

This technique is used where mouth-to-mouth ventilation is unsuccessful, for example if an obstruction in the mouth cannot be relieved, or when the rescuer is a child.

- The airway is maintained with a head tilt, but the mouth is closed with the fingers of the lower hand.
- The seal is made by the rescuer's lips around the base of the victim's nose.
- Inspiration is as above, checking to ensure that the chest rises.
- The victim's mouth is opened to assist with expiration, the rescuer watching to ensure that the chest falls.

#### **Common causes of inadequate ventilation**

- *Obstruction*: failing to maintain head tilt, chin lift.
- *Leaks*: inadequate seal around the mouth or failure to occlude the patient's nose.
- *Exhaling too hard*: trying to overcome an obstructed airway, resulting in gastric distension.
- *Foreign body*: unrecognized in the patient's airway.

#### **Circulation**

Check for evidence of a circulation:

- Look, listen and feel for normal breathing, coughing or movement by the victim.
- If you are trained, check for the presence of a pulse:





Figure 4.6 (a,b) External cardiac compression.

- Central arteries are more reliable than peripheral ones as a pulse will be palpable even with a very low cardiac output.
- The carotid artery is usually the most accessible and acceptable.
- Take no more than 10s to make the check.
- If there is no evidence of a spontaneous circulation, then chest compressions will be required.

### Chest compressions

This technique only results in a maximum cardiac output 30% of normal, and in order to achieve this the position of the hands is critical:

- The rescuer positions him/herself on one side of the victim.
- The victim's chest is exposed and the xiphisternum identified.
- The index and middle fingers of the rescuer's lower hand are placed on the xiphisternum and the heel of the other hand is placed adjacent to them on the sternum (Fig. 4.6a).
- The fingers are then removed and the heel of the

second hand placed on the back of the hand on the sternum. The fingers may then be interlocked.

- The sternum is depressed vertically 4–5 cm and then released rapidly.
- This is repeated at a rate of approximately 100/min, compression and relaxation each taking the same length of time.

To optimize compression and reduce rescuer fatigue chest compressions are best performed with the rescuer leaning well forward over the patient, arms straight and hands, elbows and shoulders extended in a straight line. This allows use of the rescuer's upper body weight to achieve compression, rather than the arm muscles, which will rapidly tire and reduce efficiency (Fig. 4.6b).

### Common errors

#### *Wrong hand position:*

- too high: the heart is not compressed;
- too low: the stomach is compressed and risk of aspiration increased;
- too laterally: injures underlying organs, for example liver, spleen, bowel.

#### *Overenthusiastic effort:*

- causes cardiac damage;
- fractures ribs which may damage underlying organs, particularly lungs and liver.

#### *Inadequate effort:*

- the rescuer is not high enough above the patient to use his/her body weight;
- fatigue during prolonged resuscitation or because of poor technique.

#### *Failure to release between compressions:*

- prevents venous return and filling of the heart.
- When a collapsed person is not breathing and has no spontaneous circulation, they will require both rescue breathing and chest compressions; this is often referred to as cardiopulmonary resuscitation (CPR). A ratio of 15 chest compressions to 2 breaths should be used, irrespective of the number of persons present. If two or more laypersons are present, they should take turns to provide single-person CPR, to prevent fatigue and maintain quality. If two or more healthcare professionals are present, then one person should perform chest compressions while another provides rescue breathing. The



same ratio of 15:2 must still be used. It is important to remember that whenever two or more people are present, irrespective of their background, one person must initially summon help, even if this results in one rescuer having to start CPR alone.

When there is only a single rescuer, the situation is more difficult. Having discovered a collapsed person, if the victim is an adult, assume the primary problem is cardiac. BLS is a 'holding procedure' and advanced skills will be required for the best chance of survival. The first action should be to telephone for help, even if it means leaving the victim; on returning, BLS can then be commenced. However, if there is evidence that the primary problem is trauma, drowning, or drug or alcohol induced, or that the victim is a child or infant, then it is appropriate to perform resuscitation for about 1 min before going for help.

### The recovery position

When the victim is breathing and has a spontaneous circulation, if safe to do so he or she should be placed in the recovery position to minimize the risks of airway obstruction and aspiration of gastric contents.

- Place the victim supine, with legs extended, and ensure airway is open (Fig. 4.7a).
- Kneeling against the victim's chest, the victim's closest arm is abducted to lie at 90° so that the palm lies facing upwards.
- The victim's far arm is then brought to lie across his or her chest, so that the back of the hand lies against the cheek (Fig. 4.7b).
- The far leg is then flexed at the hip and knee, keeping the foot on the ground.
- The far shoulder is grasped.
- The victim is then rolled. The shoulder is pulled towards the rescuer whilst at the same time the flexed leg is rotated over the lower leg using a combination of pulling on the thigh and gentle downward pressure (Fig. 4.7c).

The upper leg is adjusted so that the hip and knee are flexed and the hand under the cheek is adjusted to help maintain the head tilt (Fig. 4.7d).

### Healthcare Professional BLS

Clearly, in a healthcare environment, there is almost always help available and access to resuscitation equipment, usually oxygen, a bag-valve-mask apparatus and a monitor/defibrillator or automated external defibrillator (AED). First-responder healthcare professionals with appropriate training should use these devices to supplement BLS, in particular to reduce the time to defibrillation in those patients in a shockable rhythm. This is increasingly referred to as 'Healthcare Professional BLS' and an outline plan is given below. However, if there is any delay in obtaining resuscitation equipment, or trained personnel are not available, BLS must be started immediately.

On discovering a collapsed patient in a clinical area:

- Shout for help.
- Assess the patient's responsiveness, 'Are you right?'
- Confirm cardiac arrest:
  - Look, listen, feel for breathing for up to 10s.
  - Check for presence of a carotid pulse for up to 10s.
- If two persons are present, both should leave the patient:
  - No. 1 calls the cardiac arrest team.
  - No. 2 collects resuscitation equipment and monitor/defibrillator or AED.
- If more than two persons present, in addition to above:
  - No. 3 starts BLS while equipment is collected, 15 compressions to 2 ventilations.
  - Ventilate with airway equipment plus oxygen as soon as available (e.g. bag-valve-mask).
  - Attach monitor/defibrillator or AED as soon as possible.
  - Defibrillate if appropriate; do not delay for ventilations or chest compressions.
  - Perform two-person CPR if appropriate.
  - Hand over to the cardiac arrest team leader when the team arrives.

### Advanced life support (ALS)

The aim of ALS is to identify and reverse the underlying cause of the cardiac arrest using a



(a)



(b)



(c)



(d)

**Figure 4.7** (a–d) The recovery position.

defibrillator, airway devices, oxygen, intravenous cannulation and drugs, correcting reversible causes. The most important first step is to identify the cardiac arrest rhythm, which can belong to one of two groups:

- *Shockable*: ventricular fibrillation (VF), pulseless ventricular tachycardia (VT).
- *Non-shockable*: asystole and pulseless electrical activity (PEA).

Apart from attempting to defibrillate patients in

shockable rhythms, much of the remainder of the management is common to all rhythms. ALS management is summarized in the Universal Treatment Algorithm (Fig. 4.8). Only the key features of ALS not covered elsewhere are included here. The interested reader should refer to the Resuscitation Council (UK) for further details and is encouraged to undertake the Resuscitation Council (UK) ALS course.

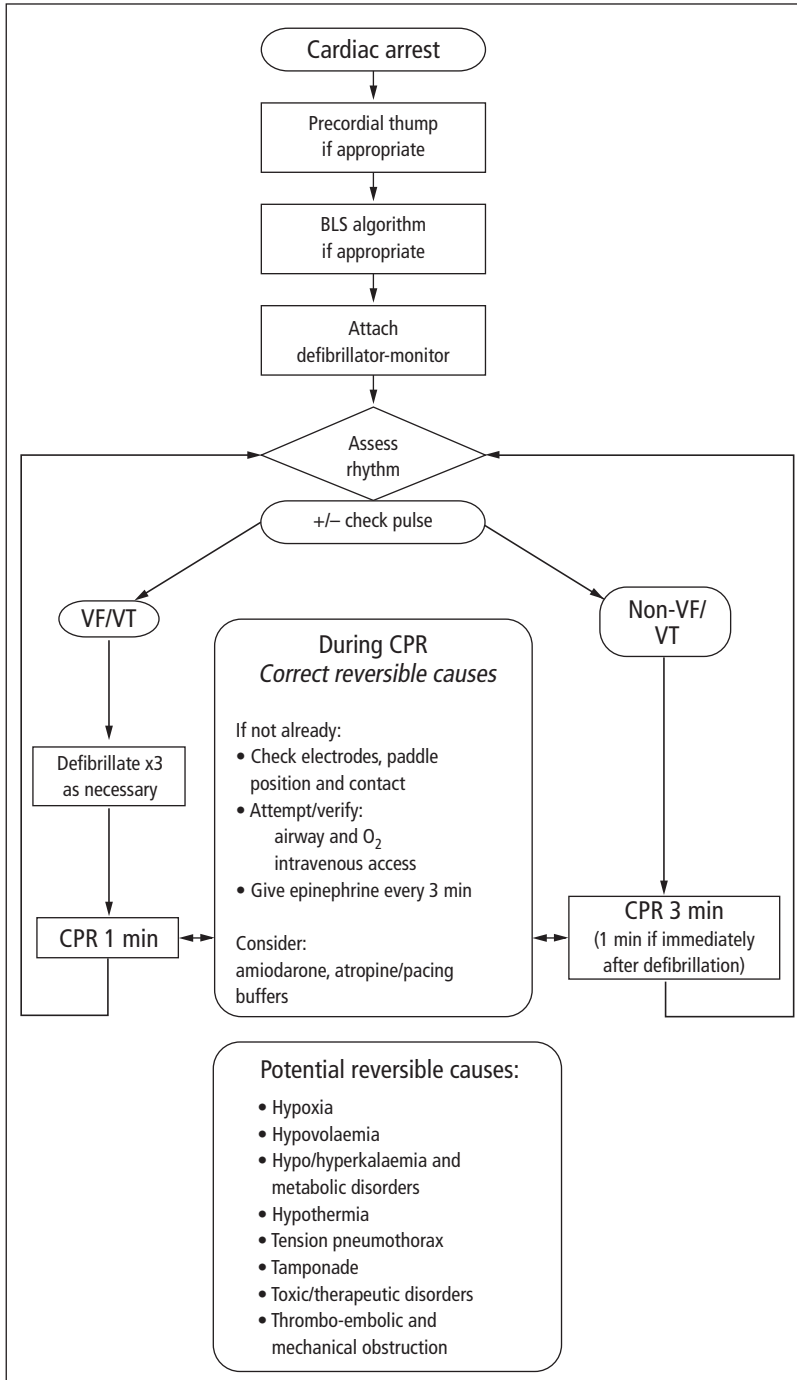

**Figure 4.8** The Universal Algorithm. Courtesy of the Resuscitation Council (UK).

## Ventricular fibrillation

The onset of VF may be preceded by a period of VT. The most effective treatment of *both conditions* is identical—electrical defibrillation (a direct current, DC, shock). The time to delivery of the first shock is critical in determining the outcome, and therefore once the diagnosis has been made, defibrillation is the first manoeuvre to be carried out in ALS. The only exception to this is when it is preceded by a precordial thump. This manoeuvre should only be used if the cardiac arrest was witnessed and/or monitored. A sharp blow is delivered to the patient's sternum with a closed fist. This delivers a small amount of mechanical energy to the myocardium and, if done early enough after the onset of VF, may cause the rhythm to revert to one capable of restoring the circulation.

### Defibrillation

Defibrillation (and cardioversion) depolarizes a critical mass of the myocardium, allowing the natural pacemaker of the heart to take over and restore a normal coordinated contraction. Defibrillators have a power source, either mains or battery, which charges a capacitor to a predetermined level. This energy is discharged through specially designed electrodes or 'paddles', usually 13–14 cm in diameter, placed on the patient's chest wall (see below). Success depends on the current flow through the myocardium and therefore to reduce the resistance between paddles and the chest wall, 'gel' pads are used. This is often referred to as 'manual defibrillation'. Increasingly, 'hands free' systems consisting of two large, self-adhesive electrodes are being used, particularly with AEDs. These allow both ECG monitoring and defibrillation without operator contact with the patient.

The paddles or self-adhesive electrodes are placed anterolateral: one to the right of the sternum, just below the clavicle; and the other over the apex, below and to the left of the nipple. Although the paddles are marked positive and negative, each can be placed in either position (Fig. 4.9). An alternative is to place them anteroposterior to the heart.



**Figure 4.9** Paddle position for external cardiac defibrillation.

### Safety

The discharge of a defibrillator delivers enough current to cause as well as to treat VF. A manual defibrillator must only be charged when the paddles are on the patient's chest and must not be moved between defibrillator and patient whilst charged. The user must ensure that nobody is in contact with the patient or trolley, directly or indirectly (via spilt electrolyte solution), when the defibrillator is discharged. Care must be taken to ensure that the paddles are not touching when on the chest, or connected by misplaced gel pads, as this will cause arcing on discharge, insufficient current delivery and the patient to be burned. Any nitrate patches should be removed from the patient's chest along with any high-flow oxygen to eliminate the risk of fire. Finally, a clear verbal warning, usually a shout of 'stand back', and a visual check of the area are mandatory before discharging the defibrillator.

If further shocks are required, the paddles should remain on the patient's chest while the defibrillator

is recharged. If the defibrillator has been charged in error while the paddles are on the patient, most devices will allow the charge to be 'dumped' safely by changing the energy level setting.

### Synchronized defibrillation

Defibrillation can be attempted at any point on the VF waveform (an unsynchronized shock). However, when the rhythm is pulseless VT, the shock is best delivered co-ordinated with the 'r' wave, that is, synchronized. This may also be referred to as cardioversion. If the shock is delivered on the 't' wave when the heart is refractory, then VF may be precipitated. Some defibrillators automatically default to synchronized mode when switched on, and unless cancelled this may delay delivery of a shock if the patient is in VF.

### Technique of safe defibrillation

- Turn on the power switch (ensure the synchronization switch is set to 'OFF').
- Put gel pads on patient's chest.
- Place paddles firmly onto gel pads.
- Select correct energy level.
- Check oxygen has been removed.
- Warn team members that you are charging the defibrillator.
- Charge the defibrillator.
- Shout 'stand back' and make a visual check of the area.
- Perform a final check of patient's ECG rhythm.
- Deliver shock by pressing both buttons on the paddles simultaneously.
- Check patient's rhythm.

### Epinephrine (adrenaline)

This is a naturally occurring catecholamine, administered during CPR for its profound  $\alpha$ -agonist (vasoconstrictor) properties. This leads to an increase in the peripheral vascular resistance that tends to divert blood flow to the vital organs (heart, brain). It is the first drug used in cardiac arrest of any aetiology. The adult dose is 1 mg intravenously, that is, 1 mL of 1:1000 or 10 mL of 1:10000, administered during ALS every 3 mins. If

IV access cannot be obtained, larger doses (2–3 mg) can be administered via a tracheal tube diluted to 10 mL with sterile water.

### Amiodarone

The main indication for this drug in cardiac arrest is during shock-refractory VF or pulseless VT, when it should be considered as early as before the delivery of the fourth shock. The adult dose in cardiac arrest is 300 mg, diluted to 20 mL and given preferably via a central line, or alternatively a peripheral line.

### Asystole

This represents electrical standstill of the heart with no contractile activity and is seen on the ECG as a gently undulating baseline. It is essential to rule out the possibility of VF having been misdiagnosed before the diagnosis of asystole is made, consequently:

- check equipment function;
- ensure that the ECG leads are connected;
- check the gain setting;
- check the lead setting, lead I or II.

If there is any doubt about the diagnosis, treatment should begin as for VF. The risks of not treating VF are greater than that of three unnecessary shocks. A precordial thump can be used under the same criteria as for VF. Occasionally, if monitoring the patient's rhythm via the paddles, 'spurious' asystole may be seen after the delivery of a shock (more likely when successive sequences of shocks have been delivered via the same pads). It is essential that the rhythm is confirmed rapidly using ECG electrodes. In general, the outcome from asystole is poor unless there are 'p' waves present that may respond to cardiac pacing.

### Atropine

An anticholinergic acting at muscarinic receptors, causing block of the vagus nerve at both the sinoatrial (SA) and atrioventricular (AV) nodes, causing an increase in heart rate. In cardiac arrest due to asystole or PEA where the heart rate is less than

**Table 4.1** Causes of pulseless electrical activity

- |   |
|---|
| <ul style="list-style-type: none"><li>• Hypoxia</li><li>• Hypovolaemia</li><li>• Hypo/hyperkalaemia and metabolic disorders</li><li>• Hypothermia</li><li>• Tension pneumothorax</li><li>• Tamponade (cardiac)</li><li>• Toxic/therapeutic disorders</li><li>• Thrombo-embolic and mechanical obstruction</li></ul> |
|---|

60 beats/min, the adult dose is 3 mg IV. A dose of 6 mg can be given via a tracheal tube.

### Pulseless electrical activity (PEA)

This is the term used to describe the situation when there are recognizable complexes on the ECG compatible with a cardiac output but the patient is pulseless. It is usually a result of conditions that mechanically restrict cardiac filling or outflow, or biochemically disrupt cardiac contractility. Common causes are listed in Table 4.1. The patient's best chance of survival is rapid identification and treatment of the underlying cause.

### Open chest cardiac compression

The output generated by direct compression of the heart is two to three times greater than closed chest compression and coronary and cerebral perfusion pressures are significantly higher. The procedure is performed via a left thoracotomy through the fourth or fifth intercostal space. It is of most use following penetrating trauma, but unlikely to benefit those in which cardiac arrest follows blunt trauma. It can also be considered in those patients in whom closed chest compression is less effective, namely severe emphysema, a rigid chest wall, severe valvular heart disease or recent sternotomy. There is no evidence to support its use as a routine procedure.

### Paediatric basic life support

The general principles are the same as for adult BLS, but specific techniques are required to take into account the altered anatomy and physiology

of children. Furthermore, if the optimum support is to be given, the techniques must be adjusted according to the size of the child. 'Infant' is used to mean those less than 1 year old and 'small children' less than 8 years old.

The evaluation of the victim is as for adults, accepting that infants and very small children who cannot yet talk, and older children who are very scared, are unlikely to reply meaningfully, but they may make some sound or open their eyes to the rescuer's voice.

### Airway control

If the child is not breathing it may be because the airway has been blocked by the tongue falling back to obstruct the pharynx. Correction of this problem may result in recovery without further intervention.

- *Head tilt plus chin lift* A hand is placed on the forehead, and the head is gently tilted back as for an adult. In an infant, the tilt should be just sufficient to place the head in a neutral position. The fingers of the other hand should then be placed under the chin, lifting it upwards. Care should be taken not to injure the soft tissue by gripping too hard. It may be necessary to use the thumb of the same hand to part the lips slightly.

- *Jaw thrust* This is achieved by placing two or three fingers under the angle of the mandible bilaterally, and lifting the jaw upwards. This technique may be easier if the rescuer's elbows are resting on the same surface as the child is lying on. A small degree of head tilt may also be applied.

The finger sweep technique often recommended for adults should not be used in children. The child's soft palate is easily damaged, causing bleeding, and foreign bodies may become impacted in the child's cone-shaped airway and be even more difficult to remove.

### Breathing

Having created an airway using one of the above techniques, the adequacy of ventilation should then be assessed rapidly in the same manner as for adults, by looking, listening and feeling for up

**Table 4.2** General guidance for expired-air ventilation

- The chest should be seen to rise and fall
- Inflation pressures may be relatively high as the airways are smaller
- Slow breaths at the lowest pressure reduce gastric distension

to 10s; if absent, expired-air ventilation will be required.

### The technique of expired-air ventilation

The airway is kept open using the techniques described above. If the mouth of the child alone is used, then the nose should be pinched closed using the thumb and index fingers of the hand, that is, maintaining the head tilt. In infants and small children, mouth-to-mouth and nose ventilation should be used. Each breath should provide sufficient volume to make the child's chest rise.

Since children vary in size, only general guidance can be given regarding the volume and pressure of inflation (Table 4.2).

If the chest does not rise then the airway is not clear:

- readjust the head tilt/chin lift position;
- try a jaw thrust;
- if both fail to provide a clear airway, suspect that a foreign body is causing obstruction.

### Circulation

Because of the difficulties in identifying the presence of a pulse, lay persons should look for signs of a circulation (normal breathing, coughing or movement) in response to ventilation. Healthcare professionals should check for a pulse; in children the carotid artery can be palpated, but in infants the neck is generally short and fat, and it may be difficult to identify; alternatives are the brachial artery on the medial aspect of the upper arm or the femoral artery. Assessment must take no more than 10s. If a pulse cannot be detected or there are no signs of a circulation, or if in an infant the heart rate is less than 60 beats/min, chest compressions will be required.

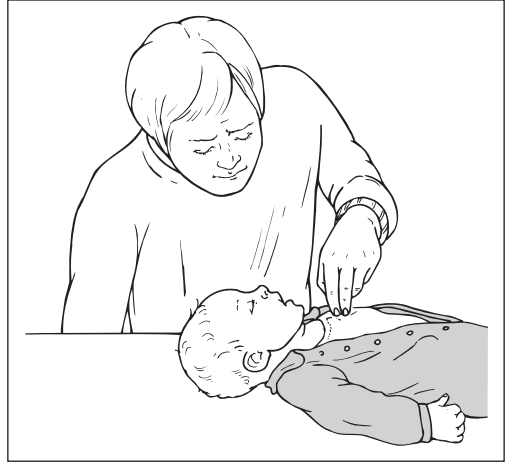
**Figure 4.10** Infant cardiac compression.

### The technique of external cardiac compression in children

Children vary in size, and the technique used must reflect this. In children over 8 years of age, the method used in adults can be applied with appropriate modifications for their size.

#### Infants

The infant heart is lower compared to external landmarks; the area of compression is found by imagining a line running between the nipples and compressing over the sternum one finger's breadth below this line. Two fingers are used to compress the chest to a depth of approximately 1.5–2.5 cm (Fig. 4.10).

An alternative in infants is the hand-encircling technique. The infant is held with both the rescuer's hands encircling the chest. The thumbs are placed over the correct part of the sternum (see above) and compression carried out.

#### Small children

The area of compression is one finger's breadth above the xiphisternum. The heel of one hand is used to compress the sternum to a depth of approximately 2.5–3.5 cm (Fig. 4.11).

*Larger children*

The area of compression is two fingers' breadth above the xiphisternum. The heels of both hands are used to compress the sternum to a depth of approximately 3–4 cm, depending on the size of the child.

Infants and children have a requirement for higher rates of ventilation and compression than adults. The aim should be to compress the sternum

at a rate of at least 100 times per minute. One ventilation should be delivered for every five compressions. Clearly, time spent readjusting the airway or re-establishing the correct position for compressions will seriously decrease the total number of compressions given per minute. This can be a very real problem for the solo rescuer and there is no easy solution. The CPR manoeuvres recommended for infants and children are summarized in Table 4.3.



Figure 4.11 Cardiac compression in a small child.

**Further reading**

Adnet PJ, Gronert GA. Malignant hyperthermia: advances in diagnostics and management. *Current Opinion in Anaesthesiology* 1999; **12**: 353–8.

Marik PE. Aspiration pneumonitis and aspiration pneumonia. *New England Journal of Medicine* 2001; **344**: 665–7.

Mendelson CL. The aspiration of stomach contents into the lungs during obstetric anesthesia. *American Journal of Obstetrics and Gynecology* 1946; **52**: 191–205.

Table 4.3 Summary of CPR manoeuvres in children

	Infant	Small child	Larger child
<i>Airway</i>	Neutral	Sniffing	Sniffing
Head tilt position			
<i>Breathing</i>	5	5	5
Initial slow breaths			
<i>Circulation</i>			
Pulse check	Brachial or femoral	Carotid	Carotid
Landmark	1 finger's breadth below nipple line	1 finger's breadth above xiphisternum	2 fingers' breadth above xiphisternum
Technique	2 fingers or encircling	1 hand	2 hands
Depth	1.5–2.5 cm	2.5–3.5 cm	3–4 cm
<i>CPR</i>			
Ratio	1:5	1:5	1:5
Cycles per minute	20	20	20



## Useful websites

<http://www.aagbi.org/pdf/Anaphylaxis.pdf>

[The Association of Anaesthetists of Great Britain & Ireland. Anaphylactic reactions associated with anaesthesia. Revised 2003.]

<http://www.resus.org.uk/pages/reaction.htm>

[Resuscitation Council UK. The Emergency Medical Treatment of Anaphylactic Reactions for First Medical Responders and for Community Nurses. Revised January 2002.]

<http://www.mhra.gov.uk/>

[Medicines and Healthcare products Regulatory Agency (UK) ensures that medicines, healthcare products and medical equipment meet appropriate standards of safety, quality, performance and effectiveness, and are used safely. Report adverse events to this agency in the UK.]

<http://www.asahq.org/publicationsAndServices/Difficult%20Airway.pdf>

[American Society of Anesthesiologists. Practice Guidelines for Management of the Difficult Airway. Revised October 2002.]

<http://www.brit-thoracic.org.uk/sign/>

[The British Thoracic Society (BTS) & Scottish Intercollegiate Guidelines Network (SIGN). British Guidelines on the Management of Asthma. February 2003.]

<http://www.leeds.ac.uk/medicine/LeedsMH.html>

[The Leeds malignant hyperthermia unit. Leeds is the national testing centre in the UK.]

<http://www.resus.org.uk/>

[The Resuscitation Council UK. This site contains the current UK guidelines for cardiopulmonary resuscitation.]

## Chapter 5

# Recognition and management of the critically ill patient

### The organization of critical care

Critically ill patients have a high morbidity and mortality. Although prompt recognition and early appropriate management of such patients helps both to minimize further deterioration and maximize the chances of recovery, it is equally important to identify and monitor closely those patients who are at risk of becoming critically ill. The Department of Health (UK) has recently identified standards for the provision and organization of hospital care required by critically ill patients and those at risk of developing critical illness. This proposes a shift in emphasis away from defining the needs of such patients in terms of hospital geography (ICU, HDU, etc.) and towards a classification system that describes escalating levels of care for individual patients, independent of their location within the hospital (Table 5.1). Although this does not obviate the requirement for ICUs and HDUs within most acute hospitals in the UK, it does envisage less direct focus on these areas, towards a more generalized, hospital-wide approach.

One of the key benefits that it is hoped will be achieved by this reorganization of care of critically ill patients is a reduction in referral to ICU and HDU by earlier recognition of warning signs that often presage the development of critical illness and cardiac arrest, thereby prompting earlier initiation of resuscitation and treatment—the so-called ‘intensive care without walls’ philosophy.

The necessary prerequisites for the successful implementation of this integrated approach to the organization of provision of care for critically ill patients are summarized in Table 5.2 and described in more detail below.

‘Critical care is a process, not a location’

### Training and education of ward-based medical and nursing staff

Recognition of patients at risk of becoming critically ill is a key point and often the limiting step in initiating appropriate management. Even when this is achieved, there is no substitute for experience when it comes to the management of critical illness, and the importance of referring such patients to senior colleagues at an early stage cannot be emphasized enough. All too often, misinterpretation of the clinical picture may lead either to a lack of action or to treatment being commenced which is inappropriate. A common example is the elderly postoperative patient who is breathless, hypotensive, oliguric and has crackles on auscultation of the chest. Acute heart failure is diagnosed and a large dose of an intravenous diuretic is given. The correct diagnosis is often pneumonia, sepsis and pre-renal failure, secondary to hypovolaemia and hypotension. Although the intravenous diuretic may initially result in a slight increase

**Table 5.1** Levels of care for critically ill patients

<p><b>Level 0</b></p> <ul style="list-style-type: none"> <li>• Patients whose needs can be met through normal ward care</li> </ul> <p><b>Level 1</b></p> <ul style="list-style-type: none"> <li>• Patients at risk of their condition deteriorating</li> <li>• Patients recently relocated from higher levels of care whose needs can be met with additional advice and support from the critical care team</li> </ul> <p><b>Level 2 (HDU)</b></p> <ul style="list-style-type: none"> <li>• Patients requiring more detailed monitoring, including support for a single organ system failure</li> <li>• Certain postoperative patients (e.g. after major surgery in high-risk patients)</li> <li>• Patients stepping down from intensive care</li> </ul> <p><b>Level 3 (ICU)</b></p> <ul style="list-style-type: none"> <li>• Patients requiring advanced respiratory support (tracheal intubation and mechanical ventilation)</li> <li>• Patients with MOFS</li> </ul>
---

Adapted from *Comprehensive critical care: a review of adult critical care services*. Department of Health, 2000. Reproduced with permission of the Controller of HMSO.

in urine output, ultimately it will exacerbate the dehydration and pre-renal failure, and may even precipitate acute cardiovascular collapse. Clinical experience is essential to correctly identify the problem and institute appropriate management, which in this case might include transfer of the patient to a high dependency area, oxygen, chest physiotherapy, a fluid challenge (perhaps guided by invasive CVP and arterial pressure monitoring), antibiotics and intravenous inotrope or vasopressor therapy.

In an attempt to overcome the deficiencies in training and education, a diverse range of courses is now available which aim to 'short-circuit' the knowledge and experience gap, including:

- *Acute Life-threatening Event Recognition and Treatment (ALERT)* Focuses on the recognition and management of patients in the early stages of developing critical illness.
- *Care of the Critically Ill Surgical Patient (CCrISP)* Focuses on the management of critically ill surgical patients.

**Table 5.2** Key features of an integrated approach to the provision and organization of care of critically ill patients

<ul style="list-style-type: none"> <li>• Earlier recognition of the deteriorating condition of susceptible patients</li> <li>• Earlier initiation of appropriate treatment/resuscitation</li> <li>• Earlier referral of patients to the critical care team</li> <li>• Extension of the resources of the ICU/HDU beyond their geographical limits</li> </ul> <p>These aims may be facilitated by the introduction of:</p> <ul style="list-style-type: none"> <li>• Improved training and education of clinical ward staff <ul style="list-style-type: none"> <li>• Doctors</li> <li>• Nurses</li> <li>• Healthcare assistants</li> </ul> </li> <li>• Use of clinical early warning scoring systems</li> <li>• Provision of an outreach team</li> </ul>
---

- *Advanced Life Support (ALS)* Focuses on the prevention and management of cardiorespiratory arrest.
- *Advanced Trauma Life Support (ATLS)* Focuses on the management of major life-threatening acute trauma.
- *Advanced Paediatric Life Support (APLS)* Focuses on recognition and management of the sick child. Attendance on courses such as these is highly recommended.

It is essential that all healthcare professionals recognize their limitations and know when to call for senior help, particularly when initial management has not led to a timely improvement in the condition of the patient. This assistance is often one's immediate clinical superior (e.g. specialist registrar or consultant) but may also include a medical emergency team (MET), an outreach team (see below) or a doctor/nurse from the ICU. However, as stated previously, these judgements are often quite complex. Accordingly, formal clinical scoring systems have been introduced in many hospitals to facilitate the process of assessing illness severity and response to treatment.

### Clinical scoring systems

- Several schemes have been described including:
- The Medical Emergency Team Calling Criteria.

**Table 5.3** The Modified Early Warning Scoring System

Score	3	2	1	0	1	2	3
HR		<40	40–50	51–100	101–110	111–129	≥130
BP	>45% ↓	30% ↓	15% ↓	Normal*	15% ↑	30% ↑	>45% ↑
RR		≤8		9–14	15–20	21–29	≥30
Temp		<35.0°C		35.0–38.4°C		≥38.5°C	
CNS**				A	V	P	U
Urine	NIL	<0.5 mL/kg/h	<1 mL/kg/h		>1.5 mL/kg/h		

HR: heart rate; BP: blood pressure; RR: respiratory rate; CNS: central nervous system.

\* Normal for patient. \*\* Assessment of conscious level; A: alert; V: responsive to verbal stimulus; P: responsive to painful stimulus; U: unresponsive.

Adapted from Stenhouse C, Coates S *et al.* Prospective evaluation of a modified Early Warning Score to aid earlier detection of patients developing critical illness on a surgical ward. *British Journal of Anaesthesia* 2000; **84**: 663P.

- The Patient At Risk Team (PART) Protocol.
- The Critical Care Liaison Service Protocol.
- The Early Warning Scoring System (EWSS).
- The Modified Early Warning Scoring System (MEWSS).

All of these are based on recording observations relating to the physiological and clinical status of the patient and the allocation of ‘points’ according to the presence and severity of any derangement from a reference range. The variables used include heart rate, arterial blood pressure, respiratory rate, body temperature, conscious level and urine output. The points derived from each variable are totalled, and advice on further clinical management is sought either on the basis of a trigger threshold being reached or because of a continued adverse trend in a patient’s score. Another subjective category is sometimes added to include any patient about whom there are serious concerns, independent of the objective scoring assessment. The importance of this latter point cannot be overemphasized, particularly when the concern is voiced by an experienced nurse who ‘doesn’t like the look’ of a particular patient. An example of one of these scoring systems is shown in Table 5.3.

The main advantages of such scoring systems are:

- their simplicity, with the need for only the basic monitoring equipment, normally present on acute hospital wards;
- their reproducibility between different observers;

- that staff require a minimum of training;
- their applicability to trainee doctors, nurses (both qualified and student) and other health professionals.

With these systems, patients at risk of developing critical illness are highlighted at an earlier stage than perhaps they otherwise would be, and appropriate treatment commenced. The other advantage is that referral arrangements by nurses and inexperienced doctors for more senior help and advice can be formalized into the protocol. Thus the ward nurse may be *required* to contact the house officer for assistance if the trigger threshold is reached. The house officer is then *required* to contact the senior house officer or registrar if immediate management does not result in an objective, timely improvement in the patient’s condition based on an improving score. This leads ultimately to direct clinical input from either a senior doctor (consultant) or outreach team from critical care if the patient is still not improving.

The use of such scoring systems cannot and must not substitute entirely for appropriate training and education of clinicians and there are several unresolved issues relating to their use. As their introduction into clinical practice has been relatively recent, there is as yet insufficient data available as to which physiological parameters are most important, and the weighting of the variables to achieve the overall score has not been validated. A doctor with experience in treating critically ill patients will not need to formally score his or her patients

**Table 5.4** Aims of outreach

- Early identification of patients with actual or potential critical illness
- Appropriate early intervention, which may prevent deterioration and avert the need for admission to HDU or ICU
- Liaison with the HDU and ICU
- Facilitate early admission to HDU and ICU when necessary
- Identification of patients for whom HDU or ICU care is deemed inappropriate
- Appropriate early designation of patients as 'not for attempted resuscitation' in the event of cardiorespiratory arrest
- To assist ward nurses in the management of patients with actual or potential critical illness
- Education and training of trainee doctors and medical students
- Promote continuity of care following step-down of patients to the ward from HDU and ICU

before deciding on the correct management. Nevertheless, it seems intuitive that scoring systems will be useful in helping less-experienced personnel identify patients at risk and in assessing the effects of their clinical intervention.

### Outreach teams

Outreach teams have been established in many hospitals in accordance with the 'intensive care without walls' philosophy as one facet of the critical care service. The aims of outreach are summarized in Table 5.4. Although one of the primary aims is to avoid admission to a critical care area, the following are also implicit:

- Outreach is not a substitute for the adequate provision and resourcing of HDU and ICU beds.
- The effective use of outreach may, paradoxically, increase demand for HDU and ICU beds by identifying more patients who might benefit from them.
- Outreach is not a substitute for adequate staffing of the general ward.

Membership of the outreach team should be multidisciplinary, although its precise makeup will vary from hospital to hospital. The team leader should be experienced in managing critically ill

patients and ideally be either an intensivist doctor (consultant or experienced specialist registrar (SpR)) or a senior intensive-care nurse practitioner. Other members of the team should include trainee doctors from acute medical and surgical specialties. The team should have easy access to other specialized personnel such as physiotherapists, pharmacists and dieticians. The proper resourcing of an effective outreach team is problematic in many hospitals, and *ad hoc* arrangements may then operate whereby patients giving rise to concern are referred to the ICU, and a 'team' consisting of an ICU trainee and/or nurse is dispatched to assess the situation and act accordingly. Clearly this is a less satisfactory approach and leads to a more fragmented level of care.

### Definition and causes of critical illness

#### Multiple organ failure syndrome

Critical illness may be defined as the failure of one or more organ systems, the most immediately life-threatening being failure of the respiratory and cardiovascular systems. Failure of other systems (e.g. renal, gastrointestinal, hepatic, central nervous system, haematological, immunological, metabolic, etc.) have their own intrinsic morbidity and mortality, as well as increasing that associated with primary cardiorespiratory failure. Critical illness due initially to a primary failure of one organ system may rapidly escalate to fulminant *multiple organ failure syndrome* (MOFS), particularly when resuscitative management is delayed, inadequate or inappropriate. Mortality correlates with the number of organ system failures and their duration:

- Patients with two or more organ system failures have a mortality of approximately 50% on the first day, rising to 66% by the fourth day.
- Patients with three or more organ system failures have a mortality of approximately 80% on the first day, rising to 95% or more by the fourth day.

A common aetiological factor in the development of MOFS in critically ill patients is ischaemia of the

gastrointestinal tract due to poor splanchnic perfusion and oxygenation in unresuscitated, shocked, hypoxic patients. The ischaemia produces damage to the mucosal integrity of the gut, a breach of its normal barrier function and *translocation* of bacteria into the circulation (septicaemia).

The causes of organ dysfunction may be classified as either primary or secondary:

- *Primary organ dysfunction* A result of direct tissue injury; for example, pneumonia in acute respiratory failure or myocardial infarction in acute cardiovascular failure (cardiogenic shock and/or acute heart failure).
- *Secondary organ dysfunction* Results from indirect tissue injury and is often the major contributor to MOFS. For example, diverticular perforation of the colon may initially cause peritonitis and septicaemia. However, the resulting release of inflammatory and toxic mediators from bacteria and host tissues may go on to trigger an escalating cascade of inflammatory mediators throughout the body, causing widespread tissue damage and organ dysfunction (systemic inflammatory response syndrome, SIRS). Secondary organ dysfunction may also develop from hospital-acquired (nosocomial) infections. Critically ill patients are at greatly increased risk of these because their immune cellular defence mechanisms are impaired by the effects of SIRS and also because natural host defence barriers are breached by invasive monitoring lines, urinary catheters, tracheal tubes, etc.

## SIRS

Any cause of systemic sepsis or major trauma may activate inflammatory mediators giving rise to this condition. Within the lungs there are non-cardiogenic alveolar and interstitial oedema, ventilation–perfusion imbalance and respiratory failure (acute respiratory distress syndrome, ARDS). Elsewhere SIRS causes profound circulatory vasodilatation, hypotension, impaired control of regional perfusion, capillary leak and systemic oedema. The final outcome of this derangement is impaired oxygen delivery and consumption at a cellular

level, leading inevitably to damage, dysfunction and ultimately cell death.

## Initial assessment and management of critically ill patients

Cardiorespiratory arrest has a high overall mortality, even when it occurs in hospital. Patients who arrest secondary to severe myocardial ischaemia or infarction have a relatively better outcome as the presenting rhythm is more likely to be ventricular fibrillation or pulseless ventricular tachycardia. Both are amenable to treatment by electrical defibrillation, particularly when a patient is in a monitored environment such as the coronary care unit (CCU), due to rapid recognition and treatment. Unfortunately, the largest group of hospital patients who have a cardiac arrest do so as the final step in a sequence of progressive deterioration of their presenting illness. The arrest rhythm is more likely to be either asystole or pulseless electrical activity (when the ECG displays complexes that would normally be associated with a cardiac output). Only a very small minority of these patients are successfully resuscitated and discharged home. Prevention of cardiac arrest in this situation is therefore the only approach likely to be successful.

Studies have shown that in this latter group of patients cardiac arrest is often predictable, with most patients exhibiting signs of clinical deterioration over the preceding 12–24 h. Features are typical of those listed above in clinical scoring systems, and include:

- respiratory distress and tachypnoea (respiratory rate >30/min);
- tachycardia (heart rate (HR) >120/min);
- a fall in cardiac output manifest as hypotension, confusion, drowsiness and metabolic acidosis.

If these warning signs are heeded and appropriate resuscitative measures commenced, cardiac arrest may be prevented and lives saved. Alternatively, if it is decided (by a senior clinician) in advance of the event that cardiac arrest is inevitable and that resuscitation is unlikely to benefit the patient, a DNAR (do not attempt resuscitation) order may be made. It should be noted that a DNAR order does

not preclude appropriate resuscitative measures up to the point of actual cardiac arrest.

### Action on receiving a call to a sick patient

When requested to see a patient who is giving cause for concern, it is helpful to have asked a few pertinent questions of the referrer concerning the patient's recent history, so that you are already thinking about potential diagnoses and treatment as you make your way there. For example:

- How old is the patient?
- When was the patient admitted to hospital?
- What did the patient come into hospital with?
- Is the patient conscious, and if so what is he or she complaining of?
- How quickly has the patient deteriorated?
- What are the patient's pulse rate, blood pressure, respiratory rate, temperature, skin colour?
- Does the patient have a DNAR order?

Do not attempt to acquire a comprehensive medical and surgical history since birth in a patient whose airway, breathing or circulation may be threatened, or in whom cardiorespiratory arrest is imminent!

The effective management of these patients has two key elements:

- A systematic approach must be used that deals with the greatest potential threat first.
- Call early for senior help if the situation appears beyond your capabilities, or if the patient continues to deteriorate despite what you consider to be appropriate management.

### Initial approach

In assessing any critically ill patient, it is essential to follow the ABC system, that is Airway, Breathing, Circulation. The principles of ABC management are discussed in the chapter on cardiorespiratory arrest and the application of this system in relation to the patient who has not yet progressed to cardiac arrest is given below.

On approaching the patient for the first time, much useful information may be gleaned by simply asking: 'Are you alright?' The reply: 'I don't feel

very well, doctor' tells you at the very least that the patient has control of his or her airway, is breathing, and has sufficient cerebral perfusion to process the question and formulate an appropriate answer. Failure to respond appropriately to the question should immediately suggest the possibility of an acute life-threatening physiological disturbance and the possibility of cardiorespiratory arrest.

### Airway—assessment and management

Acute upper airway obstruction may be either complete or partial. If left untreated the patient may die within minutes. Assuming the patient is attempting to breath:

- Look and listen for evidence of obstruction:
  - partial obstruction results in noisy breathing (gurgling, snoring, crowing);
  - complete obstruction is silent;
  - movements of the chest are usually exaggerated and a see-saw pattern is often observed, with the chest being drawn in on inspiration as the abdomen rises; the opposite movements occur during expiration;
  - accessory muscles may be used, for example sternomastoids.

Common causes of airway obstruction are listed in Table 5.5.

On the general medical or surgical ward, impaired consciousness is the most common cause of airway obstruction. It can usually be relieved using basic airway-opening manoeuvres such as the head tilt plus chin lift or jaw thrust (see page 99). Insertion of simple airway adjuncts (Guedel oral airway

**Table 5.5** Causes of upper airway obstruction

- |   |
|---|
| <ul style="list-style-type: none"> <li>• Impaired conscious level—reduced muscle tone allows the tongue to fall back and occlude the airway</li> <li>• Blood, vomit or other secretions</li> <li>• Trauma</li> <li>• Laryngeal oedema due to anaphylaxis or thermal injury</li> <li>• Inhaled foreign body (e.g. food bolus)</li> <li>• Tumour</li> <li>• Infection (e.g. retropharyngeal abscess)</li> </ul> |
|---|

or nasopharyngeal airway) may also be required (see page 18). Airway obstruction due to vomit, blood, food or secretions in the mouth and pharynx may be apparent on inspection and dealt with by careful suction using a rigid, wide-bore sucker.

Even if these simple steps relieve the airway obstruction, it is vital to call for experienced help at this stage, often from an anaesthetist, who may decide that tracheal intubation and transfer to the ICU is necessary. Airway obstruction secondary to pathology in and around the upper airway itself, such as a laryngeal tumour or trauma to the head and neck, mandates a call for immediate expert assistance.

### Breathing assessment and management

Breathing is initially assessed using the look, listen and feel approach (see page 100). Assuming the airway has been cleared and the patient is breathing:

- Count the respiratory rate:
  - Rapid breathing (>30 breaths/min) is an early sign of clinical deterioration that may progress to cardiac arrest.
  - Abnormally slow breathing (rate <8/min) may indicate terminal exhaustion of the patient or brain stem depression due to ischaemia, hypoxia or drugs (e.g. opioids).
- Look for the presence of cyanosis (peripheral or central).
- Examine the chest, palpating, percussing and auscultating for primary and secondary respiratory problems.
- Pulse oximetry and arterial blood gas analysis provide useful additional information.

Do not forget:

- Severe respiratory failure may be masked by administration of a high concentration of inspired oxygen to the patient. A normal  $P_{aO_2}$  (12–14 kPa) breathing 100%  $O_2$  is NOT normal!
- When the oxygen saturation of arterial blood is 90% the  $P_{aO_2}$  is only 8 kPa.
- A hypoxaemic patient will usually hyperventilate, resulting in a low  $P_{aCO_2}$ .
- A high  $P_{aCO_2}$  in the presence of hypoxaemia is an ominous sign: it usually indicates exhaustion of the patient.

There are numerous causes of respiratory failure. They may be classified as to whether respiratory failure from lung disease is the primary problem or secondary to other problems (Table 5.6). Both primary and secondary causes may coexist in the same patient.

The treatment for hypoxaemia is administration of oxygen in high concentration, ideally to achieve a normal  $P_{aO_2}$  (12–14 kPa) or peripheral oxygen saturation (=95%). At the very least, minimum respective targets of 8 kPa and 90% should be aimed for. This is most easily achieved by using a face-mask with an attached reservoir bag connected to oxygen at a flow rate of 15 L/min (see Fig. 3.2). Ensure the reservoir is filled with oxygen before placing it on the patient's face. This apparatus will provide an inspired oxygen concentration of approximately 85%. Oxygen therapy per se does not treat the cause of hypoxaemia and respiratory failure; the next step is to ascertain the cause and treat appropriately.

### The patient with chronic obstructive pulmonary disease (COPD)

The spectre of the patient with severe chronic respiratory disease, chronic hypoxia and a hypoxic drive to breathing is a frequent cause of concern and confusion for the inexperienced. The worry is that administration of a high concentration of oxygen will remove the respiratory drive of such patients and produce hypoventilation with increasing hypercapnia, progressing to unresponsiveness and respiratory arrest. However, these patients represent a minority. There are two key points to remember:

- Patients will die as a consequence of withholding oxygen in high concentration because of an unwarranted concern about hypoxic drive.
- Patients do not die of hypercapnia—they die of hypoxia.

Unless the patient's history strongly suggests *severe* chronic respiratory disease, give a high concentration of oxygen.

Oxygen should be administered at a lower concentration (e.g. 28–40%) to patients in whom a hypoxic drive is strongly suspected and the response



**Table 5.6** Causes of respiratory failure on the ICU

Primary lung dysfunction	Secondary causes
<ul style="list-style-type: none"> <li>• Pneumonia</li> <li>• Acute asthma</li> <li>• Acute exacerbation of COPD</li> <li>• Emphysema</li> <li>• Pulmonary fibrosis</li> <li>• Pneumothorax/haemothorax</li> <li>• Pulmonary contusion</li> </ul>	<ul style="list-style-type: none"> <li>• Exhaustion</li> <li>• ARDS</li> <li>• Acute heart failure</li> <li>• Pulmonary embolism</li> <li>• Airway obstruction</li> <li>• Neuromuscular problems               <ul style="list-style-type: none"> <li>• Myopathies</li> <li>• Neuropathies</li> <li>• Guillain–Barré syndrome</li> </ul> </li> <li>• Myasthenia gravis</li> <li>• CNS depression               <ul style="list-style-type: none"> <li>• Drugs</li> <li>• Head injury</li> <li>• Meningitis/encephalitis</li> <li>• Cerebral haemorrhage</li> <li>• Cerebral tumour</li> <li>• Cerebral hypoxia</li> </ul> </li> <li>• Diaphragmatic splinting               <ul style="list-style-type: none"> <li>• Morbidly obese patients</li> <li>• Abdominal pain</li> <li>• Abdominal distension</li> </ul> </li> </ul>

carefully observed, both clinically and by repeating arterial blood gas analysis at frequent intervals (e.g. every 30 mins). The aim should still be to achieve the minimum targets stated above, although it is acknowledged that in a small group of patients with severe chronic respiratory disease, even lower target levels for  $P_{aO_2}$  may be acceptable. However, these patients require the early involvement of an expert to make what are complex judgements of the risks/benefits of intervention.

In patients who fail to improve with simple oxygen therapy, call for expert help early. They may require:

- continuous positive airway pressure (CPAP);
- non-invasive positive pressure ventilation (NIPPV);
- invasive ventilation.
- *CPAP* A breathing system is attached to a tightly fitting facemask to ensure that a positive pressure is maintained throughout the respiratory cycle during the patient's spontaneous respiratory efforts (Fig. 5.1). The apparatus is designed to maintain a

flow greater than the patient's peak inspiratory flow rate to minimize the work of breathing. The positive airway pressure improves oxygenation by increasing functional residual capacity (FRC, the resting volume of the lungs at the end of a normal expiration), re-expanding collapsed areas of the lungs (recruitment) and reducing the tendency of airways to collapse during expiration. Nasal CPAP may also be administered.

- *NIPPV* A mechanical ventilator is connected to a close-fitting facemask to avoid leaks and allow positive pressure assistance of the patient's own respiratory efforts. A nasal mask can also be used and CPAP may be applied. The patient is not sedated as this would inhibit spontaneous respiratory effort. Such patients may be managed on the medical HDU or a specific respiratory care unit.

- *Invasive ventilation* The patient is anaesthetized, intubated and then sedated to tolerate the tracheal tube. Full mechanical ventilation is provided, independent of the patient's own efforts. Admission to the ICU is necessary.



**Figure 5.1** Demonstration of a CPAP system. (A) High flow of oxygen to patient; (B) tight-fitting facemask; (C) expiratory valve to maintain a positive pressure throughout the respiratory cycle.

Although a full discussion of the respective merits of these two approaches to ventilation is beyond the scope of this book, there is increasing evidence that the morbidity and mortality of patients with an acute exacerbation of COPD is reduced when non-invasive ventilation is used prior to consideration of tracheal intubation. Acute ventilatory failure due to other causes, particularly in the context of a critically ill patient with multiple organ system failure, usually necessitates ICU admission and invasive ventilation.

### Circulation—assessment and management

Circulation is once again assessed using the look, listen and feel approach. Assuming the patient has a pulse, observe for signs of an adequate circulation:

- rate, volume and rhythm of the pulse (it may only be possible to detect a large central pulse over the carotid, brachial or femoral arteries);
- respiratory rate, conscious level;
- peripheral skin temperature, colour and capillary refill time (apply firm pressure to the patient's finger or toe for 5 s and release: capillaries should refill within 2 s);
- measure the blood pressure;
- measure urine output.

Do not forget:

- A thready, weak, rapid pulse with peripheral pallor and cool skin is suggestive of circulatory shock associated with a low cardiac output.
- A bounding, easily felt rapid pulse with a warm periphery may be due to septic shock. Cardiac output is often normal or even elevated despite a low blood pressure.

Automated non-invasive blood pressure devices are less reliable if the peripheral pulse is weak or irregular. Obtain a systolic reading by manual use of a sphygmomanometer, noting the point at which the brachial pulse is just palpable. An arterial line provides reliable, continuous blood pressure data. However, appropriate skill is required to insert one, and operate the specialized monitoring equipment, and nurses must be experienced in managing such patients. Accordingly, it will usually be necessary to transfer such patients to a high dependency area.

Heart rate and blood pressure must be placed in the context of what is normal for that individual patient. An elderly patient with poor myocardial reserve may be *in extremis* with a heart rate of 60/min and a blood pressure of 90/50 mmHg, although the same values may be well tolerated or even normal for a fit young adult. A relative bradycardia developing after a tachycardia must never be assumed to indicate an improvement in the

**Table 5.7** Causes of systemic hypotension

<p><b>Hypovolaemia</b></p> <ul style="list-style-type: none"> <li>• Dehydration/inadequate fluid intake</li> <li>• Haemorrhage</li> <li>• Severe vomiting/diarrhoea</li> <li>• Burns</li> <li>• Abnormal fluid losses into the gut</li> <li>• High output fistula of the small bowel</li> </ul> <p><b>Cardiogenic causes</b></p> <ul style="list-style-type: none"> <li>• Acute myocardial ischaemia/infarction</li> <li>• Severe valvular heart disease</li> <li>• Cardiomyopathy</li> <li>• Acute myocarditis</li> <li>• Constrictive pericarditis</li> </ul> <p><b>Sepsis</b></p> <ul style="list-style-type: none"> <li>• Any cause of systemic sepsis</li> </ul> <p><b>Neurogenic</b></p> <ul style="list-style-type: none"> <li>• High spinal cord injury</li> </ul> <p><b>Anaphylaxis</b></p>
--

condition of the patient as it may herald an impending cardiac arrest—the patient's *overall* condition and progress must be considered.

The causes of systemic hypotension are summarized in Table 5.7.

It may be possible, from the history and clinical examination, to arrive at a reasonably certain working diagnosis and treat accordingly. For example:

- A patient on the CCU with acute myocardial infarction and severe hypotension probably has cardiogenic shock.
- A hypotensive patient found on a surgical ward on the day after major abdominal surgery with abdominal distension and surgical drains full of blood is probably hypovolaemic.
- A patient with pneumonia, a high pyrexia and elevated white cell count who is hypotensive with a rapid, bounding pulse is probably septic.

As a general rule, nearly all patients with clinical signs of an inadequate circulation such as tachycardia and hypotension respond well to a fluid challenge:

- If not already done, establish intravenous access.
- Give a rapid bolus of 500 mL over approximately 15 mins.

- Observe the patient for signs of improvement—decreased pulse and respiratory rate, improved level of consciousness, increased blood pressure, etc.
- Repeat the fluid challenge, as indicated by the patient's response.

The choice of what type of fluid to use at this stage (crystalloid or colloid) is probably less important than the fact that fluid (any fluid) is being given. However, dextrose-containing solutions are not used for initial resuscitation as they rapidly distribute throughout the entire intracellular and extracellular fluid compartments of the body, with little remaining in the circulation. Where there is evidence of significant blood loss or ongoing haemorrhage, give blood or arrange urgent cross-match.

The aim of this initial treatment is to buy time by stabilizing the condition of the patient in order to make a definitive diagnosis and arrange for more expert management. Patients who are unresponsive to fluid resuscitation alone may have ongoing fluid losses (e.g. bleeding or extravasation of circulating fluid through leaky capillaries in sepsis syndrome) that require addressing, or complementary treatment with inotropes, vasopressors and invasive haemodynamic monitoring (e.g. CVP and pulmonary artery flotation catheter (PAFC); see page 125). These patients should be referred to the appropriate expert.

Patients with severe hypotension due to poor left ventricular performance after acute myocardial infarction (cardiogenic shock) may not tolerate a rapid, large fluid bolus because the filling pressure of the left ventricle is already increased and its muscle fibres are overstretched. If the clinical diagnosis is fairly certain:

- If not already done, establish intravenous access.
- Give fluid in slower, smaller aliquots (250 mL).
- Monitor the response very closely, preferably with the aid of invasive haemodynamic monitoring (e.g. arterial line, CVP and PAFC).

These patients often need:

- reduction of the high preload to the left ventricle using diuretics and intravenous nitrates (e.g. glyceryl trinitrate, GTN);
- reduction of afterload using intravenous arterial vasodilators;

- inotropic support to assist in supporting the failing myocardium.

Dobutamine, a synthetic catecholamine, is most commonly used. Its actions are predominantly via  $\beta$ -adrenoceptors, increasing myocardial contractility and causing arteriolar vasodilatation in skeletal muscle reducing afterload via  $\beta_2$ -adrenoceptors.

Such patients should be considered as being at very high risk of cardiac arrest from which the prognosis is likely to be poor. They must be managed in a high dependency area (e.g. CCU) by experienced clinicians.

A standard 12 lead ECG should also be performed in any patient with warning cardiorespiratory signs, and will provide valuable information of significant myocardial ischaemia or infarction. A rapid irregular pulse is likely to be due to atrial fibrillation. This may need additional treatment with either anti-arrhythmic drugs (e.g. digoxin, amiodarone) or synchronized electrical cardioversion using a defibrillator (see page 106). Patients causing serious concern should be continuously monitored by ECG, pulse oximeter and invasive arterial monitoring.

Acute heart rhythm disturbances and their immediate management are summarized in Table 5.8.

## Cardiac arrhythmias

Common tachycardias and sinus bradycardia and their causes have been covered on pages 77–78.

**Table 5.8** Acute heart rhythm disturbances and their immediate management

<p><b>Sinus tachycardia</b></p> <p>Usually an appropriate cardiovascular response to maintain cardiac output and blood pressure—treat the cause, not the tachycardia itself:</p> <ul style="list-style-type: none"> <li>• Hypovolaemia</li> <li>• Myocardial ischaemia/infarction</li> <li>• Sepsis</li> <li>• Severe pain</li> <li>• Anxiety</li> <li>• Thyrotoxicosis</li> </ul> <p><b>Supraventricular tachycardia</b></p> <ul style="list-style-type: none"> <li>• In critically ill patients usually atrial fibrillation, particularly the elderly</li> <li>• Often indicates inadequate intravascular volume</li> <li>• Treat using synchronized electrical cardioversion or drugs depending on the degree of urgency (see page 77)</li> </ul>	<p><b>Sinus bradycardia</b></p> <p>Identify and treat the underlying cause:</p> <ul style="list-style-type: none"> <li>• Impending cardiac arrest</li> <li>• Hypoxia</li> <li>• Drug toxicity</li> <li>• Hypothermia</li> <li>• May be normal in young fit adults</li> <li>• Raised intracranial pressure</li> <li>• Heart block                             <ul style="list-style-type: none"> <li>• May pre-exist or be associated with acute myocardial ischaemia/infarction</li> <li>• Second- and third-degree heart block may quickly progress to ventricular standstill (cardiac arrest)</li> <li>• Needs insertion of a temporary transvenous pacing wire</li> </ul> </li> </ul> <p><b>Ventricular tachycardia</b></p> <ul style="list-style-type: none"> <li>• Usually associated with acute myocardial ischaemia/infarction</li> <li>• Relatively uncommon presentation in critical illness due to other causes</li> <li>• Potentially compatible with a pulse but may also rapidly deteriorate into a cardiac arrest</li> <li>• Requires immediate treatment, usually by defibrillation unless 'well tolerated' by the patient, when drugs (e.g. amiodarone) may be tried initially</li> </ul> <p><b>Ventricular fibrillation, asystole and pulseless electrical activity</b></p> <p>See pages 105–108</p>
--	---



**Figure 5.2** Typical view of an ICU patient to show the large amount of equipment required. Ventilator and monitors are on the patient's right, syringe pumps delivering drugs are on the left.

## The intensive care unit

### An overview

The intensive care unit (ICU) is a designated area within a hospital where specialized treatment of critically ill patients takes place (Level 3 care, Fig. 5.2). In order to achieve this, there is a concentration of resources, including:

- a wide range of complex monitoring equipment;
- mechanical ventilators;
- facilities for organ support;
- the use of potent drugs, which are often given by continuous intravenous infusion;
- a high nurse to patient ratio, typically 1:1;
- a medical resident who is continuously available exclusively for the ICU.

The service is genuinely consultant-led; that is, consultants (predominantly anaesthetists in the UK) are closely involved with all day-to-day management of critically ill patients, and with supervising, directing and training nurses and doctors. The out-of-hours commitment of such consultants is onerous as they are normally present on the ICU to directly supervise the initial management of all newly referred critically ill patients, admissions to the ICU and inter-hospital ICU transfers.

Complementing, or in lieu of the ICU, there may be a high dependency unit (HDU) where the level of care is intermediate between that found on the ICU and the general ward (Level 2 care). Patients on the HDU are not normally mechanically ventilated. Patients suffering from acute myocardial infarction are generally admitted to specialized coronary care units (CCUs), while neurosurgical and head-injured patients may be admitted to a specialized area of the neurosurgical ward for short periods of mechanical ventilation.

The demand for intensive care is increasing steadily as a result of advances in clinical management, and also because of the ever-increasing expectations from society that almost no patient, regardless of age or co-morbidity, should be denied admission to the ICU. Currently the UK has relatively fewer general or specialist intensive care beds, 2.6% of all acute hospital beds, compared with 4.1% in Denmark and approximately 8% in the United States. This under-provision, coupled with average ICU bed occupancy rates (80–90%) that tend to be much higher than the ideal (60–70%), means that there are relatively frequent occasions when no local ICU bed can be found for a critically ill patient. Hospitals now have formalized arrangements for transferring patients to other ICUs in such circumstances. It has been suggested that in order to maximize clinical and

financial efficiency, much larger regional ICUs should be established although little progress has been made in this regard.

The challenge for those involved in the care of critically ill patients is to aim precious resources at those patients likely to survive, by providing artificial support of one or more failing physiological systems until natural recuperation and/or therapeutically assisted recovery can take place. Patients may be admitted to the ICU electively following major surgery, or as medical or surgical emergencies. In an attempt to differentiate potential survivors from non-survivors, a number of scoring systems have been developed which take into account various aspects of the patient's acute physiological upset, age and any chronic health problems (e.g. APACHE II—Acute Physiology and Chronic Health Evaluation). However, none of these scoring systems is sufficiently accurate to be used as the sole basis for deciding whether or not to treat an *individual* patient. Ultimately, there is no substitute for the clinical judgement of an experienced intensivist (consultant).

### Monitoring on the intensive care unit

Physiological monitoring is an essential aid in the diagnosis and management of critically ill patients, in evaluating their response to treatment and alerting staff to the onset of a sudden deterioration in the patient's condition. There is a spectrum of monitoring. At its most basic level it comprises clinical observation and examination (which, although 'low technology', remains of vital importance), extending to complex, invasive methods for the measurement of haemodynamic, oxygen transport and other variables (Fig. 5.3).

### Electrocardiogram (ECG)

All patients should have a continuously displayed ECG for the detection of acute arrhythmias, and to a lesser extent (except on the CCU), acute ischaemia. In critically ill patients on the general ICU, supraventricular tachycardias predominate, especially sinus tachycardia and atrial fibrillation.

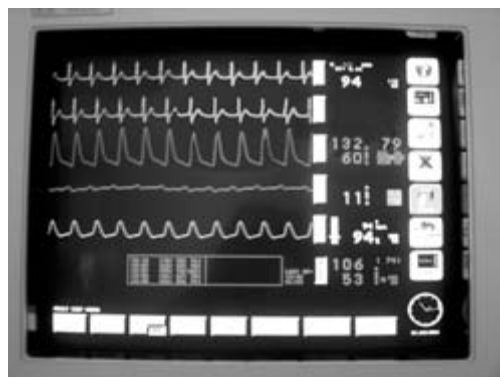

Figure 5.3 ICU monitor displaying ECG, invasive blood pressure and waveform, CVP and waveform, SpO<sub>2</sub>.

### Arterial blood pressure

In health, systemic arterial blood pressure is closely regulated to maintain an adequate pressure to ensure tissue perfusion. In critically ill patients, mean arterial pressure (MAP) should normally be maintained above a minimum value of 70 mmHg. However, it may be appropriate to aim for a higher value in elderly patients (as blood pressure tends to increase with age) and in patients with known hypertension. It is very helpful to know what is 'normal' for an individual patient and such information may be available in the patient's case notes.

MAP is dependent on cardiac output and systemic vascular resistance (SVR) according to the formula:  $MAP = CO \times SVR$ . Measurement of arterial blood pressure is thus a relatively crude indicator of cardiac performance and circulatory flow, as it may be normal or elevated in the presence of a low cardiac output and poor tissue perfusion. Interpretation of the blood pressure must be taken in the context of other clinical measurements such as the state of the peripheral circulation, urine output and trends in acid–base balance. In critically ill patients it is often more useful to measure the cardiac output itself (see below).

Arterial blood pressure is usually monitored invasively on the ICU as it is more accurate, and continuous, and the presence of an indwelling arterial cannula allows blood sampling without the need

**Table 5.9** Advantages and disadvantages of direct arterial blood pressure measurement**Advantages**

- Accuracy
- Continuous measurement gives immediate warning of important changes in blood pressure
- Shape of arterial waveform gives information relating to myocardial contractility and other haemodynamic variables
- Facility for frequent arterial blood sampling

**Disadvantages**

- Complex to perform
- Potentially inaccurate if apparatus is not set up correctly
- Haematoma at puncture site
- Infection at puncture site/bacteraemia/septicaemia
- Disconnection haemorrhage
- Embolization
- Arterial thrombosis

for repeated puncturing of veins or arteries. The advantages and disadvantages of direct measurement are shown in Table 5.9. A cannula is inserted percutaneously into a suitable artery, usually the radial artery of the non-dominant hand (common alternatives being the femoral and dorsalis pedis arteries, less commonly the brachial and axillary arteries). The arterial blood pressure is transmitted via a saline-filled catheter to a pressure transducer that converts the mechanical signal to a very small electrical signal, proportional to the pressure. This signal is amplified and displayed on a monitor as both a waveform and pressure readings: systolic, diastolic and mean. Exposing the transducer to atmosphere and ensuring that the monitor reads zero pressure ensures accuracy of the system. To prevent the system becoming blocked, it is flushed constantly with heparinized saline at approximately 3 mL/h from a pressurized source to prevent backflow. Central venous and pulmonary artery pressures are measured using the same system.

Recently, devices have become available that analyse the shape of the arterial waveform (pulse contour analysis) and derive stroke volume, and, by knowing heart rate, allow cardiac output to be determined. The arterial line is modified to incorporate an electrode sensitive to lithium. A

**Table 5.10** Uses of central vein catheterization

- Measurement of central venous pressure
- Infusion of:
  - irritant solutions, e.g. KCl
  - vasoconstrictor agents, e.g. noradrenaline, dopamine
  - parenteral nutrition
- Insertion of temporary cardiac pacing wire
- Insertion of pulmonary artery flotation catheter
- Venous access:
  - for haemodialysis, haemofiltration, plasmapheresis, etc.
  - in the absence of peripheral veins
  - during cardiac arrest

measured dose of lithium is injected intravenously and cardiac output is calculated from the resultant lithium dilution curve. This value is used to calibrate the pulse contour analysis and is normally performed only 2–3 times per day. The clear advantage of this system is that continuous cardiac output monitoring of critically ill patients is possible without requiring an invasive technique other than the arterial line itself, which is already routinely inserted into nearly all patients on the ICU.

### Central venous pressure (CVP)

This is an index of the patient's circulating volume (or more correctly right ventricular preload). It is useful for directing fluid therapy in cases of dehydration, hypovolaemia due to haemorrhage and sepsis syndrome, and in the diagnosis and management of heart failure. The routes commonly used to measure CVP are discussed on page 58. A central venous cannula may also be used for a variety of other purposes in the ICU, as shown in Table 5.10.

The main limitation in monitoring CVP is that therapy is directed towards optimizing the filling pressures on the right side of the heart. While the filling pressures of the right and left sides are normally closely related, this relationship may not always be reliable in critically ill patients, particularly those with pre-existing cardiac or



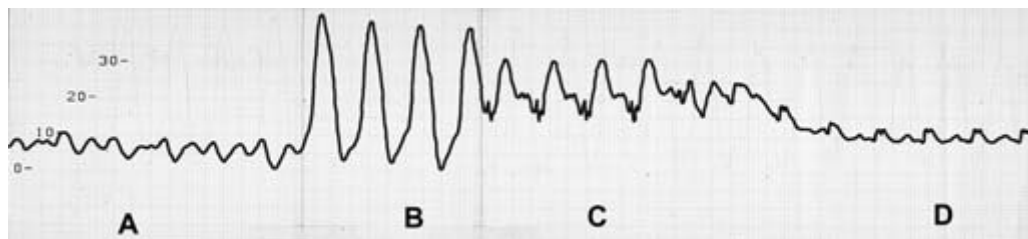

**Figure 5.4** Pressure trace on insertion of PA catheter; (A) in right atrium, (B) in right ventricle, (C) in pulmonary artery, (D) in pulmonary artery with balloon inflated ('wedged').

respiratory disease. In this situation it is of greater therapeutic value to monitor and optimize conditions for the left ventricle.

### Pulmonary artery pressures

Pressures in the pulmonary artery are monitored using a PAFC. This is a multi-lumen catheter with an inflatable balloon and a temperature thermistor at its distal end.

A PAFC is inserted percutaneously via either the internal jugular or subclavian vein in the same manner as inserting a CVP line. Once the catheter is in a central vein, as indicated by the pressure waveform, the balloon is inflated. The flow of blood through the heart carries the balloon forward so that it can be advanced through the right atrium and ventricle until the tip lies in a main branch of the pulmonary artery (Fig. 5.4). In this position, an indirect assessment of the filling pressure in the left ventricle can be made. The pressure obtained is commonly referred to as the wedge pressure because the balloon is advanced until it 'wedges' in the pulmonary artery. The wedge pressure is usually closely related to the left ventricular end-diastolic pressure (LVEDP). This is a more accurate indication of the preload to the left ventricle than the CVP. The wedge pressure is influenced by many of the factors affecting CVP and trends are more useful than absolute values. Complications associated with PAFC insertion are listed in Table 5.11.

In addition to invasive pressure data, the catheter can also be used to measure cardiac output and allow mixed venous blood to be sampled. Re-

**Table 5.11** Complications of pulmonary artery catheterization

- All of the complications associated with central venous catheterization
- Ventricular dysrhythmias
- Pulmonary infarction
- Pulmonary artery rupture
- Knot formation
- Balloon rupture
- Subacute bacterial endocarditis
- Pericardial tamponade
- Damage to tricuspid or pulmonary valve

cently, PAFCs have become available that incorporate two fiberoptic channels and measure mixed venous oxygen saturation continuously. One channel transmits near infrared light that is reflected by the passing red cells; a second fiberoptic channel conducts the reflected light to a photodetector that determines the oxygen saturation of the haemoglobin.

### Pulse oximetry

The pulse oximeter provides a simple, non-invasive, continuous assessment of the oxygenation of the peripheral tissues ( $SpO_2$ ). It therefore gives a simultaneous indication of the degree of oxygenation of the blood by the respiratory system and the ability of the cardiovascular system to deliver it to the tissues. By providing continuous monitoring it can be used to give an early warning of deterioration in a patient's condition. The principles of operation are described on page 50.



## Transoesophageal echocardiography

Transoesophageal echocardiography (TOE) can provide sophisticated information relating to ventricular size and performance, valvular function and cardiac output. The technique is relatively non-invasive, the sensor being positioned via the oesophagus to lie behind the heart, similar to the technique for inserting a gastroscope. Monitoring is continuous, and acute changes in cardiac output can be detected. The use of TOE on the ICU is increasing and many intensivists now prefer TOE to insertion of a PAFC. The main limitation to more widespread adoption of TOE is the expense of the apparatus.

## Renal function

In critically ill patients, acute renal failure is a common problem. Although there are many causes of renal failure (Table 5.12), in the critically ill it usually results from failure to maintain an

adequate renal perfusion pressure (pre-renal failure) due, for example, to hypovolaemia. The kidneys attempt to maintain blood pressure and circulating volume by producing a minimal volume and maximal concentration of urine. However, once urine production falls below approximately 500 mL/day, the kidneys are unable to excrete all the waste products of metabolism, with the result that uraemia, metabolic acidosis and hyperkalaemia develop.

If the reduction in renal perfusion and oxygenation is severe enough, not only does urine production stop but the kidneys also become ischaemic. Severe widespread necrosis may then ensue, mainly affecting the tubules (acute tubular necrosis, ATN), culminating in oliguria or anuria. Once ATN has developed, even restoration of a satisfactory blood pressure and circulating volume will not lead to immediate restoration of urine production. However, if the patient is appropriately resuscitated, there is a good chance that renal function will eventually recover as the patient recovers, although there is often a delay of 2–3 weeks before urine production restarts. When it does, it is typically high output, low concentration in nature, when particular attention needs to be paid to fluid and electrolyte balance.

Although pre-renal factors are commonly implicated in acute renal failure affecting critically ill patients, some patients may already have pre-existing intrinsic chronic renal failure due to other causes. The two may also be present together (acute on chronic renal failure). The distinction between pre-renal and intrinsic renal failure may be aided by biochemical investigations (Table 5.13).

All patients on the ICU should have their plasma urea, creatinine and electrolytes (Na, K, Ca, Mg, phosphate, etc.) measured at least once daily, and urine output monitored hourly. Estimation of glomerular filtration rate (GFR) from the creatinine clearance ( $CL_{CR}$ ) is a more precise index of renal function and is easily derived from a sample of urine taken overnight:

$$GFR \approx CR_{CL} = \frac{\text{rate of urinary output} \times \text{urine [Cr]}}{\text{plasma [Cr]}}$$

**Table 5.12** Aetiology of acute renal failure

### Pre-renal

- Dehydration, e.g. vomiting, diarrhoea
- Haemorrhage
- Cardiogenic shock
- 'Third space losses', e.g. trauma, major surgery, bowel obstruction, etc.

### Renal

- Acute tubular necrosis (usually secondary to severe pre-renal failure)
- Sepsis
- Severe obstructive jaundice
- Blood transfusion reaction
- Myoglobinaemia
- Peritonitis

### 'Medical' causes

- Acute pyelonephritis
- Acute glomerulonephritis
- Acute pancreatitis
- Nephrotic syndrome
- Bowel obstruction
- Vasculitis
- Burns
- Renal vein thrombosis

**Table 5.13** Differentiation of pre-renal from intrinsic renal failure

Index	Pre-renal	Intrinsic renal
Urine concentration	High	Dilute
	Specific gravity $\geq 1020$	Specific gravity 1010
	Osmolarity $>550$ mosmol/L	Osmolarity $<350$ mosmol/L
Urine (Na)	$<20$ mmol/L	$>40$ mmol/L
Urine/plasma osmolar ratio	$\geq 2:1$	1.1:1
Urine/plasma urea	$\geq 20:1$	$<10:1$
Urine/plasma creatinine	$\geq 40:1$	$<10:1$

### Neurological assessment

Neurological assessment of patients on the ICU is often difficult because of the use of sedatives and neuromuscular blocking drugs. Ideally, muscle relaxants should be avoided unless absolutely necessary for the safe management of the patient. A minimal level of sedation should be employed, titrated for each individual and compatible with a comfortable, settled patient who is nonetheless easily rousable. Formalized scoring systems such as The Glasgow Coma Scale (GCS) and Ramsay sedation scale (see Table 5.16) can be used, provided that allowances are made for the effects of drugs and the presence of a tracheal tube. Patients who have undergone major intracranial surgery or sustained a severe head injury may have their intracranial pressure (ICP) monitored. A variety of devices are available that are placed, via a small (burr) hole in the skull, into the brain parenchyma, lateral ventricle, subarachnoid or extradural space. The aim is to keep the ICP below 20 mmHg whilst maintaining cerebral perfusion pressure (MAP-ICP) above approximately 70 mmHg.

### Hepatic function

Hepatic dysfunction may be primary, or more commonly in the context of critically ill patients, secondary to another disease process (Table 5.14). Liver function is monitored by serum bilirubin (conjugated/unconjugated), albumin, transaminases (AST, ALT, GGT), alkaline phosphatase, prothrombin time (PT) and activated partial thromboplastin time (APTT). The PT is probably

**Table 5.14** Causes of hepatic dysfunction

<p><b>Primary</b></p> <ul style="list-style-type: none"> <li>• Viral hepatitis, A, B, C, cytomegalovirus, Epstein–Barr virus, etc.</li> <li>• Alcoholic liver disease</li> <li>• Drug-induced hepatitis: halothane, sodium valproate, isoniazid, paracetamol overdosage</li> <li>• Autoimmune hepatitis/cirrhosis</li> <li>• Acute fatty liver of pregnancy</li> <li>• Inborn error of metabolism, e.g. Wilson’s disease</li> </ul> <p><b>Secondary</b></p> <ul style="list-style-type: none"> <li>• Sepsis syndrome</li> <li>• Hypoxia</li> <li>• Hypotension</li> <li>• Cardiac failure</li> <li>• Cholestasis</li> <li>• Cholangitis</li> </ul>
--

the most sensitive indicator of hepatic reserve and prognosis in fulminant liver failure.

### Miscellaneous

Routine haematology (haemoglobin concentration, white cell count, platelet count) should be assessed daily. Trace elements (e.g. Cu, Zn, Se) may need monitoring in patients who are resident on the ICU for more than a week, particularly during parenteral nutrition. Serum lactate levels are measured on some ICUs as a more specific indicator of metabolic acidosis associated with tissue hypoxia.

## Mechanical ventilation on the intensive care unit

One of the commonest interventions on the ICU is mechanical ventilation of critically ill patients who have developed respiratory failure, or when respiratory failure is thought to be imminent in an exhausted patient. Hypoxaemia ( $PaO_2 \leq 8$  kPa) with or without accompanying hypercapnia ( $Paco_2 \geq 6.6$  kPa) is usually present despite high-flow oxygen therapy. The aim of mechanical ventilation is to optimize oxygenation of the patient and to allow a period of respite by relieving the patient of the work of breathing. The causes of respiratory failure are diverse (Table 5.6). A common presentation in patients admitted to the ICU is the acute respiratory distress syndrome (ARDS). Following a variety of insults, pulmonary capillaries become hyperpermeable, with leakage of fluid and the development of non-cardiogenic pulmonary oedema. This results in areas of ventilation/perfusion mismatch, severe hypoxaemia, tachypnoea and, eventually, physical exhaustion as the patient tries to compensate.

During mechanical ventilation, the physiological negative pressure phase of spontaneous inspiration is replaced by a positive pressure phase in which respiratory gas is driven into the lungs by the ventilator. As a result, the distribution of gas flow through the lungs, and the shape of the chest wall and the pattern and extent of diaphragmatic movement is altered. This tends to lead to a small increase in ventilation/perfusion mismatching. However, the net result of mechanical ventilation in patients with respiratory failure is usually beneficial in improving arterial  $PaO_2$  and  $Paco_2$  values. The reasons for this include:

- reliable administration of up to 100%  $O_2$ ;
- reduced oxygen consumption by a sedated, ventilated patient;
- ventilation with larger tidal volumes than can be achieved by the dyspnoeic patient breathing spontaneously;
- application of positive end expiratory pressure (PEEP).

The latter two measures increase the functional residual capacity (FRC) of the lungs above a critical

level (the closing volume). In turn, this reduces the extent of collapse of small airways, thus improving ventilation/perfusion matching.

Positive pressure ventilation may also relieve a failing left ventricle and alleviate cardiogenic pulmonary oedema by reducing venous return to the heart as the intrathoracic pressure rises during inspiration. The abnormally high left ventricular preload accompanying left ventricular failure is reduced and the overstretched muscle fibres are able to return to a more optimal size for efficient contraction. Mechanical ventilation may also reduce left ventricular afterload as it produces a positive pressure gradient between the thoracic and abdominal aorta during inspiration. Although the gradient is relatively small, the reduction in work required of the left ventricle may be significant.

Critically ill patients requiring ventilation often have a reduction in lung compliance and an increase in resistance to respiratory gas flow. Consequently, ICU ventilators are principally electronically controlled and programmed to ensure that the desired tidal volume is delivered (Fig. 5.5). They allow the intensivist a great deal of control over the pattern of inspiratory gas flow and adjustment of the time taken for inspiration and expiration, usually expressed as the inspiratory to expiratory (I:E) ratio. Furthermore, a variety of modes are available which allow patients' own inadequate respiratory efforts to be assisted, such as pressure support ventilation and synchronized intermittent mandatory ventilation (SIMV).

## Intubation and tracheostomy

The majority of patients on the ICU are ventilated through a cuffed tracheal tube inserted via the mouth or, much less commonly, via the nasal route. The cuff should have a large volume to minimize the pressure exerted on the tracheal mucosa. An orotracheal tube is very uncomfortable; patients usually require sedation and analgesia to tolerate its presence and it is associated with difficult oral hygiene, infection and ulceration. These factors become a much more significant problem during the period of recovery when attempts are being made to wean the patient off



**Figure 5.5** ICU ventilator. Soft keys allow control of ventilator settings with display of volumes and pressures generated.



**Figure 5.6** Percutaneous tracheostomy kit showing needle for initial puncture, Seldinger wire and tapered dilator.

ventilatory support, as it now becomes necessary to reduce the level of sedation and analgesia to facilitate this process. Furthermore, it is well known that the prolonged presence of an orotracheal tube is associated with a higher incidence of long-term complications, particularly tracheal stenosis. Accordingly, if the period of tracheal intubation extends beyond approximately 7–10 days, it is usual to perform a tracheostomy. Until recently, this necessitated a formal surgical procedure in the operating theatre, usually by an ENT surgeon.

However, most tracheostomies are now performed using a percutaneous technique on the ICU by the intensivists using purpose-designed kits. In the most popular method, a tapered dilator is passed along a guidewire through a small incision, until the track is large enough to accommodate the tracheostomy tube (Fig. 5.6). Percutaneous tracheostomy is simple and quick to perform (usually less than half an hour), and is associated with a very low incidence of complications. Consequently, it is increasingly performed relatively soon after the patient's admission to the ICU, particularly when it is anticipated that weaning of the patient may be delayed or difficult.

### Sedation and analgesia

Critically ill patients admitted to the ICU require varying degrees of sedation and analgesia. These are not synonymous terms and require different drugs and techniques. Many critically ill patients are confused and disorientated by their illness and are likely to become agitated by their environment. For patients with insight, the realization of the seriousness of their condition and the contemplation of their own mortality can be frightening, and the psychological trauma engendered may hinder recovery. An appropriate level of sedation

**Table 5.15** Problems associated with deep sedation with paralysis

- Immunosuppression
- Increased incidence of infection
- Prolonged recovery times
- Loss of contact with reality, with an adverse effect on psychological well-being
- Increased incidence of ICU neuropathy (weakness and wasting of skeletal muscle)

**Table 5.16** Ramsay sedation scale

Level	Conscious level
1	Restless and agitated
2	Co-operative, calm, orientated
3	Asleep, responds to verbal command
4	Asleep, responds briskly to glabellar tap
5	Asleep, responds sluggishly to glabellar tap
6	No response

produces calm, co-operative patients who are thus easier to nurse and treat. Similarly, patients admitted to the ICU following major surgery or trauma will suffer if good analgesia is not provided. Many of the invasive procedures that are undertaken on patients are also painful and, as mentioned above, even the presence of the tracheal tube itself can be distressingly uncomfortable. As recently as 10–20 years ago, it was common practice to deeply sedate and paralyse all patients so that they were completely unaware of their surroundings. It is now realized that such deep sedation is not only unnecessary, but may also be harmful (Table 5.15).

The ideal level of sedation is one in which the patient is calm, awake and orientated during appropriate periods of the day. The Ramsay sedation scale (Table 5.16) is used on many ICUs, a score of 2–4 being considered satisfactory depending on the clinical situation, time of day, etc.

The most commonly used sedative drugs are midazolam and propofol. Opioids such as morphine, fentanyl, alfentanil and remifentanil are used when analgesia is required. Regional anaesthetic techniques are also used, particularly continuous epidural analgesia using a combination of a low

**Table 5.17** Indication for total parenteral nutrition and associated complications**Indications**

- Ileus following major bowel surgery
- Acute pancreatitis
- Inflammatory bowel disease
- Short bowel syndromes
- Malabsorption syndromes
- Multiple organ failure
- Postoesophagectomy
- Severe catabolic states, e.g. extensive burns, sepsis, trauma

**Complications**

- Central line sepsis
- Acute gastric erosion
- Hyperglycaemia
- Specific mineral or vitamin deficiencies
- Less satisfactory nutrition of the luminal mucosa of the gut

concentration of local anaesthetic and opioid (see page 86). This technique is suitable for pain relief following surgery or trauma to the thorax, abdomen, pelvis and lower limbs. It is often easier to wean patients off mechanical ventilation more quickly in the presence of epidural analgesia as they are more able to take deep breaths and cough forcefully, uninhibited by pain or the respiratory depressant effects of systemic opioids.

**Nutrition**

Maintenance of adequate nutrition is an essential element of the care of critically ill patients. Where possible, patients should be fed enterally and there is no reason why feeding cannot be commenced on day one in many patients. *If the gut is working, use it!* Enteral feeding is simpler to administer, less expensive, more physiological and associated with fewer complications than total parenteral nutrition (TPN). The presence of food within the gut also stimulates blood flow and facilitates earlier recovery of normal gastrointestinal function. Indications for TPN and associated complications are listed in Table 5.17.

**Table 5.18** Risk factors for nosocomial infection on the ICU

- Extremes of age
- Pre-existing medical conditions
- Poor nutritional status
- Immunosuppressive effect of illness, drugs
- ICU is a breeding site for antibiotic-resistant strains of bacteria
- Breach of body surface defences:
  - Tracheal intubation
  - Urinary catheter
  - IV and arterial lines
- Raised intragastric pH due to H<sub>2</sub>-antagonists

Critically ill patients are at risk of developing acute erosion and ulceration of the gastric mucosa, particularly those who are unable to tolerate enteral feeding when the action of gastric acid is unopposed. The most appropriate method of ulcer prophylaxis is provision of enteral nutrition at the earliest opportunity. Inhibition of gastric acid production itself (e.g. with ranitidine or omeprazole) provides prophylaxis against acute gastric ulceration when enteral feeding is not possible. However, abolishing the acid environment of the stomach also risks causing bacterial overgrowth that may lead to the development of so-called ventilator-associated pneumonia.

### Infection control

Hospital-acquired (nosocomial) infections are common on the ICU and are associated with increased morbidity and mortality. They are increasingly due to multiply antibiotic-resistant organisms such as methicillin-resistant *Staphylococcus aureus* (MRSA). Critically ill patients on the ICU have a number of risk factors for developing infection (Table 5.18). Common infections involve the lower respiratory tract in ventilated patients, septicaemia associated with IV and arterial lines, and surgical wound infections. Prevention of nosocomial infection should be a priority (Table 5.19). The single most important aspect of prevention is the practice of good hygiene standards.

**Table 5.19** Prevention of nosocomial infection on the ICU

#### Good basic hygiene standards

- Scrupulous washing of hands immediately before and after contact with patient; wearing of gloves and aprons
- Regular disinfection of ventilator tubing or use of disposable equipment
- Use of bacterial/viral filters between patient and ventilator
- Insertion of IV lines, catheters under full asepsis
- Regular toileting of patient, particularly surgical wounds and sites of insertion of IV lines, catheters
- Routine changing of IV and arterial lines after a defined period (not proven to be effective)

#### Optimize nutritional status of patient

**Avoid overuse of 'prophylactic' broad-spectrum antibiotics**

### Common conditions treated on the intensive care unit

#### Respiratory failure

The causes of respiratory failure and the principles of mechanical ventilation have already been discussed. The most important therapy is oxygen—a life-saving 'drug'. It must be administered in sufficient concentration to raise the  $P_{aO_2}$  to an acceptable level, usually = 10.5 kPa (80 mmHg). All severely hypoxic patients should be given as close to 100% oxygen as possible, by facemask initially. Unfortunately, as described earlier, many patients are denied high-flow oxygen therapy, due to unwarranted concern that their respiration is dependent on a hypoxic drive. Only a minority of patients with *severe* chronic obstructive airways disease (classically described as blue bloaters) are dependent on a hypoxic ventilatory drive and these patients should have their oxygen therapy carefully titrated. It is not that unusual to find patients without any previous history of chronic obstructive airways disease receiving 28% oxygen because of such fears, and the authors have even seen young, fit patients admitted with acute severe asthma being denied 100% oxygen. It is important

to remember that it is the partial pressure of oxygen in arterial blood ( $P_{aO_2}$ ) that is responsible for respiratory drive, *not* the inspired oxygen concentration. If there are serious concerns regarding a severely hypoxic patient with chronic respiratory disease and a suspected hypoxic ventilatory drive, immediate referral to an expert is advised.

Although pulmonary oxygen toxicity may occur when oxygen is administered in a concentration >40% for a prolonged period, it is both illogical and dangerous to withhold higher concentrations in hypoxic patients with severe respiratory failure. In any case, oxygen toxicity is more closely correlated with  $P_{aO_2}$  than inspired oxygen concentration.

The majority of patients admitted to the ICU require mechanical ventilation. Many of these have ARDS and require the use of high inflation pressures to provide an adequate tidal volume. In ARDS, the lungs become very stiff (decreased compliance) due to alveolar and interstitial oedema, acute inflammatory infiltrates, atelectasis and pulmonary fibrosis. Although it is obvious that these patients would die without mechanical ventilation, in recent years it has become increasingly apparent that mechanical ventilation itself may further injure the lung in critically ill patients. This lung damage is caused by high inflation pressures (barotrauma), over-distension of more compliant areas of the lung (volutrauma) and trauma due to repeated 'snapping' open and closed of collapsed alveoli during inspiration and expiration (atelectrauma). There is now good evidence that limiting inflation pressures by accepting lower tidal volumes (e.g. 6 mL/kg rather than 10–12 mL/kg) may reduce ICU length of stay and mortality. Application of a high PEEP pressure (approximately 15 cmH<sub>2</sub>O) also helps to minimize the extent of alveolar collapse and atelectrauma. This 'protective ventilatory strategy' is therefore becoming more widespread in the UK, using a combination of a specialized mode of ventilation called pressure-controlled ventilation (PCV), a reversed I:E ratio and high PEEP. One of the consequences of protective ventilation is an increased  $P_{aCO_2}$  and respiratory acidosis—permissive hypercapnia. However, this is tolerated by most critically ill patients.

Appropriate antibiotics should be given in the presence of a chest infection. It is essential to obtain a specimen of sputum for microbiological examination and antibiotic-sensitivity testing, ideally from the *lower* respiratory tract. Bronchodilators may be useful in patients with bronchospasm associated with asthma or chronic obstructive airways disease, chest infection, pulmonary aspiration or ARDS. Bronchodilators are commonly administered as a nebulized mist directly to the respiratory tract (e.g. salbutamol, ipratropium). They may also be given by IV infusion (salbutamol, adrenaline, aminophylline), although there is a greater risk of arrhythmias. Effective physiotherapy is an essential part of respiratory care for all patients on the ICU. Techniques used by physiotherapists in helping to expectorate secretions from the lungs include the positioning of patients to facilitate postural drainage of secretions and percussion of the chest to help loosen secretions. Suctioning of the trachea and upper airways is important as nearly all critically ill patients, whether sedated and paralysed or not, are incapable of coughing effectively because of generalized muscle weakness.

Two other techniques practised on many ICUs in severe respiratory failure and ARDS are:

#### **Pulmonary arterial vasodilator therapy (inhaled nitric oxide (NO) gas or nebulized prostacyclin)**

The rationale for vasodilator therapy is that the inhaled drug is delivered only to well-ventilated alveoli where it is a potent pulmonary arterial vasodilator. Pulmonary arterioles associated with poorly ventilated alveoli remain unaffected. It may be anticipated that this will lead to an improvement in the ventilation to perfusion ratio and in practice the initial response of the patient is often a significant improvement in oxygenation. However, the results of clinical trials have been disappointing and there is as yet insufficient data available to demonstrate a beneficial effect on actual mortality from ARDS.



## Prone ventilation of patients

The potential benefits of this technique are derived from the fact that prolonged adoption of the supine posture leads to collapse of dependent (posterior) areas of the lung, increasing ventilation–perfusion mismatch. Reversing the posture facilitates re-expansion of the dependent lung. Prone ventilation has become common practice on many intensive care units after the publication of several relatively small studies that showed beneficial results. However, a recent much larger study failed to demonstrate any effect on mortality and the place of routine prone ventilation of patients with ARDS is now questionable. Turning patients prone is potentially hazardous and may result in accidental extubation of the patient, the pulling out of CVP and arterial lines, and pressure damage affecting the eyes and face. However, when undertaken by teams of doctors and nurses experienced in the procedure, the risk of complications is low.

## Cardiovascular failure

The principles of treatment of cardiovascular failure are to optimize:

- conditions for the left ventricle in order to achieve an appropriate preload, stroke volume, cardiac output and hence oxygen delivery to the tissues;
- the state of the circulatory system so that the cardiac output is distributed to vital organs at sufficient pressure for capillary beds to be well perfused. In clinical practice, these principles are followed by:
  - *Correcting hypovolaemia with fluid challenges* Increasing left ventricular preload so that it is functioning at the peak of the Frank–Starling curve. This first step is the single most important prerequisite for optimal cardiovascular performance.
  - *Treating arrhythmias adversely affecting cardiac performance* The most common on the ICU is atrial fibrillation and this sometimes resolves spontaneously when the patient is adequately fluid resus-

citated. Intravenous amiodarone is the most effective drug used to treat atrial fibrillation in critically ill patients, and acts either by reducing the ventricular response rate or by pharmacological cardioversion back into sinus rhythm.

- *Improving myocardial contractility* An inotropic agent (e.g. dobutamine) may be required to increase cardiac output to a satisfactory level. Cardiac output may be monitored using a PAFC, oesophageal Doppler ultrasound probe or arterial pulse wave contour analysis.

In severe sepsis syndrome, MAP is often inadequate in spite of a normal or even elevated cardiac output. In this situation a vasopressor (a drug that vasoconstricts systemic arterioles) is necessary, for example noradrenaline.

Vasodilators are only occasionally useful on the ICU to ‘offload’ a failing left ventricle. The majority of patients who benefit from these drugs have usually suffered a myocardial infarction. They are not usually mechanically ventilated and are admitted to the CCU rather than the ICU.

The use of inotropes and vasopressors require invasive monitoring of the cardiovascular system to direct therapy.

## What targets should be aimed for with respect to MAP and cardiac output in critically ill patients with multiple organ failure?

Useful clinical variables include the state of the peripheral circulation (cold and shut down or warm and well perfused), trends in acid–base balance and urine output (although urine output is of little use in the context of acute renal failure). Lactic acid is produced by anaerobic metabolism and trends in serum lactate concentration can provide useful information on whether or not oxygen delivery to the tissues and oxygen consumption by the tissues is adequate.

It is usually appropriate to aim for a MAP of at least 70 mmHg. However, elderly patients and patients with pre-existing hypertension may require a significantly higher arterial pressure. On the other hand, younger patients may tolerate a lower



pressure. Defining a satisfactory cardiac output in critical illness is more problematic. It is known that oxygen requirements are elevated during critical illness. Thus, values of cardiac output within the 'normal range' may be inadequate. Until relatively recently, it was quite commonplace to attempt to drive the cardiac output to the maximum attainable using a combination of fluid loading and inotropic support. However, most intensivists now adopt a more conservative approach, following evidence that driving the cardiovascular system towards 'supranormal goals' did not improve mortality and could even increase it. Accordingly, when cardiac output is measured, values at the upper end of normal or moderately above it are accepted as satisfactory, taken in the overall context of a stable or improving clinical situation.

### Acute renal failure

Critically ill patients who have acute renal failure as a component of their multiple organ failure have significantly different requirements in terms of renal support from patients with isolated acute or chronic renal failure. An inherently unstable cardiovascular system, the need for continued infusion of large volumes of fluid to combat the extravasation of circulating volume through leaky capillaries and the use of potent inotropic and vasopressor drugs mean that these patients are often unable to tolerate the rapid fluid and ionic shifts associated with intermittent haemodialysis techniques, which may precipitate cardiovascular collapse. Peritoneal dialysis is also of limited value in the ICU as it does not have the capacity to maintain homeostasis in hypermetabolic patients or remove fluid rapidly enough when required. In addition, it is often not possible in patients after abdominal surgery and those with abdominal sepsis. Therefore, continuous haemofiltration (a process analogous to the filtration that occurs naturally in the glomeruli of the kidneys) is generally used as the preferred method of renal support on the ICU. An extracorporeal circulation is set up, containing a filter with an artificial semi-permeable membrane. Previously, flow through the filter was driven by the patient's own arterial

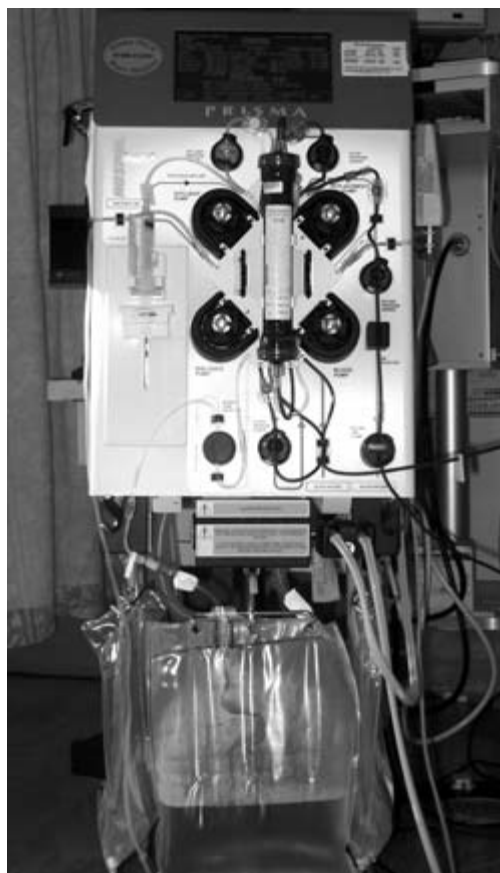

**Figure 5.7** CVVH equipment. The vertical, central structure is the filter/dialysis membrane. There are four pumps: bottom right pumps blood in from a central vein into the filter; bottom left pumps fresh dialysate fluid into the filter; top left pumps out effluent from the filter (consisting of dialysate fluid plus ultrafiltrate); and top right pump delivers replacement fluid to the patient to maintain fluid balance.

pressure (continuous arteriovenous haemofiltration, CAVH). It is now more usual to employ venovenous haemofiltration (CVVH) driven by a mechanical roller pump (Fig. 5.7). In addition, modern equipment permits the use of combination therapy in which both haemofiltration and dialysis occur simultaneously (CVVHD). The maximum creatinine clearance obtained is much less than that during haemodialysis. Consequently, CVVH must be run continuously in contrast to the short (several hours) intermittent (2–3 times per

**Table 5.20** The systemic inflammatory response syndrome

Defined as the presence of two or more of the following:

- Temperature  $>38^{\circ}\text{C}$  or  $<36^{\circ}\text{C}$
- Heart rate  $>90$  beats/min
- Tachypnoea  $>20$  breaths/min or  $\text{Paco}_2 <32$  mmHg
- White blood cell count  $>12 \times 10^9/\text{L}$ , or  $<4 \times 10^9/\text{L}$ , or  $>10\%$  immature forms

week) episodes of standard haemodialysis. However, as alluded to above, this disadvantage is also an advantage in that it promotes haemodynamic stability.

### Sepsis syndrome and SIRS

These two terms are often used interchangeably. Although there is considerable overlap between them, they describe subtly different clinical conditions.

- *Sepsis syndrome* A condition in which the host is overwhelmed by an infecting organism, classically a Gram-negative bacterium, producing endotoxin and/or exotoxins. Endotoxin is a lipopolysaccharide component of the cell membrane of Gram-negative organisms, whereas exotoxins are bacterial products that may be released into the circulation.

- *SIRS* The clinical manifestations of the hypermetabolic state seen after any major insult to the body, and defined in Table 5.20. The insult may be infection in which case SIRS and sepsis syndrome describe the same pathophysiology. However, infection is not the only trigger for SIRS and other causes include major trauma, burns and acute pancreatitis.

The clinical features of sepsis syndrome and SIRS are similar, with hypermetabolism, circulatory shock due to systemic vasodilatation and extravasation of fluid (via leaky capillaries). In the lungs, these manifestations present as ARDS. Elsewhere, oxygen delivery to cells is compromised by shunting of blood away from capillary beds through arteriovenous channels that open in response to the inflammatory response. Oxygen consumption by cells may also be reduced as a consequence of intracellular dysfunction of the mitochondria. The

result of all these derangements is lactic acidosis due to oxygen supply–demand imbalance, the development of an oxygen debt and an increase in anaerobic metabolism.

Like any other inflammatory response, SIRS is a physiological mechanism for defence of the body after a major insult, facilitating eradication of infection and tissue repair. The problem is that the host response becomes amplified and uncontrolled, contributing to further tissue damage and dysfunction.

The principles of treating sepsis syndrome and SIRS are the provision of support for failing organ systems (optimization of oxygenation of arterial blood, mechanical ventilation, fluid resuscitation, inotropic and vasopressor drugs, haemofiltration, clotting factors, etc.), and targeting any infecting organism with appropriate antibiotic therapy. This may require repeated blood cultures and analysis of specimens of sputum, urine, and wound and catheter sites to identify the organism responsible. If a collection of pus within the thorax, abdomen, pelvis or elsewhere is a clinical possibility, it must be sought aggressively using ultrasound scanning, computerized tomography (CT) scan or laparotomy. Such patients do *not* recover if surgical drainage is not undertaken.

There have been attempts to target the abnormal inflammatory cascade caused by the circulating inflammatory mediators. Earlier studies examining the efficacy of monoclonal antibodies to one of the principle cytokines, tumour necrosis factor (TNF) were disappointing and failed to demonstrate any clinical advantage. However, it is possible that advances in this area may be made as further research elucidates more detailed information concerning the pathophysiology of sepsis syndrome and SIRS. More recently, evidence has emerged of the efficacy of activated protein C (APC), a natural circulating anticoagulant. APC levels are decreased in severe sepsis due to both excessive consumption and reduced activation, and the size of the decrease correlates with mortality. Consequently, microthrombi develop throughout the circulation in sepsis syndrome and this is one of the main causes of end-organ dysfunction. The process is inhibited by APC. In a recent large double-blind, placebo-

controlled study, administration of APC to patients with multiple organ failure associated with sepsis syndrome resulted in a decrease in mortality from 30.8 to 24.7%. APC is currently being evaluated in the UK. Tight control of blood sugar during critical illness also improves survival. When intensive insulin therapy is used to maintain blood sugar between 4.4 and 6.1 mmol/L, ICU mortality is reduced (4.6 versus 8%) when compared with standard therapy.

## Further reading

The Acute Respiratory Distress Syndrome

Network. Ventilation with lower tidal volumes as compared with traditional tidal volumes for acute lung injury and the acute respiratory distress syndrome. *New England Journal of Medicine* 2000; **342**: 1301–8.

Bernard GR, Vincent JL, Laterre PF *et al.*, and the Recombinant human protein C Worldwide Evaluation in Severe Sepsis (PROWESS) study group. Efficacy and safety of recombinant human activated protein C for severe sepsis. *New England Journal of Medicine* 2001; **344**: 699–709.

Boldt J. Clinical Review: hemodynamic monitoring in the intensive care unit. *Critical Care* 2002; **6**: 52–9.

Galley HF. *Critical care focus 1: renal failure*, 1st edn. London: BMJ Books, 1999.

Galley HF. *Critical care focus 2: respiratory failure*, 1st edn. London: BMJ Books, 1999.

Galley HF. *Critical care focus 5: antibiotic resistance and infection control*, 1st edn. London: BMJ Books, 2001.

Gattinoni L, Tognoni G, Pesenti A *et al.* Effect of prone positioning on the survival of patients with acute respiratory failure. *New England Journal of Medicine* 2001; **345**: 568–73.

Hodgetts TJ, Kenward G, Vlackonikolis I *et al.* Incidence, location and reasons for avoidable in-hospital cardiac arrest in a district general hospital. *Resuscitation* 2002; **54**: 115–23.

Lightowler JV, Wedzicha JA, Elliott MW. Non-invasive positive pressure ventilation to treat respiratory failure resulting from exacerbations

of chronic obstructive pulmonary disease: Cochrane systematic review and meta-analysis. *British Medical Journal* 2003; **326**: 185.

McQuillan P, Pilkington S, Allan A *et al.*

Confidential inquiry into quality of care before admission to intensive care. *British Medical Journal* 1998; **316**: 1853–8.

Meduri GU, Headley AS, Golden E *et al.* Effect of prolonged methylprednisolone therapy in unresolving acute respiratory distress syndrome. *Journal of the American Medical Association* 1998; **280**: 159–65.

NHS Estates. *Facilities for critical care*. Health Building Note 57. London: The Stationary Office, 2003.

Nolan J, Baskett P, Gabbott D *et al.* *Advanced life support provider course manual*, 4th edn. London: Resuscitation Council (UK), 2000.

Oh TE. *Intensive care manual*, 5th edn. London: Butterworths, 2003.

Rivers E, Nguyen B, Havstad S *et al.* Early Goal-Directed Therapy Collaborative Group. Early goal-directed therapy in the treatment of severe sepsis and septic shock. *New England Journal of Medicine* 2001; **345**: 1368–77.

Smith GB, Osgood VM, Crane S. ALERT: a multiprofessional training course in the care of the acutely ill adult patient. *Resuscitation* 2002; **52**: 281–6.

Van den Berghe G, Wouters P, Weekers F *et al.* Intensive insulin therapy in the critically ill patients. *New England Journal of Medicine* 2001; **345**: 1359–67.

## Useful websites

<http://www.doh.gov.uk/compcritcare/index.htm> [Department of health (UK). Comprehensive Critical Care. Review of adult critical care services. June 2000.]

<http://www.ics.ac.uk/> [The Intensive Care Society (ICS). The publication section contains current UK national guidance on all aspects of critical care.]

[http://www.sccm.org/professional\\_resources/guidelines/table\\_of\\_contents/index.asp](http://www.sccm.org/professional_resources/guidelines/table_of_contents/index.asp) [This site contains current publications from

the Society of Critical Care medicine (SCCM) and reflects North American practice.]

<http://www.cmmtutorials.com/>

[Excellent, up-to-date interactive critical care tutorials.]

[http://www.americanheart.org/](http://www.americanheart.org/presenter.jhtml?identifier=9181)

[presenter.jhtml?identifier=9181](http://www.americanheart.org/presenter.jhtml?identifier=9181)

[The American Heart Association scientific-statements section has numerous up-to-date guidelines.]

[http://www.modern.nhs.uk/criticalcare/5021/](http://www.modern.nhs.uk/criticalcare/5021/7117/78001-DoH-CareOutreach.pdf)

[7117/78001-DoH-CareOutreach.pdf](http://www.modern.nhs.uk/criticalcare/5021/7117/78001-DoH-CareOutreach.pdf)

[NHS Modernisation Agency. Critical Care Outreach 2003. This report contains guidance on current best practice in this area.]

<http://www.brit-thoracic.org.uk/pdf/NIV.pdf>

[Guidelines on non-invasive ventilation in acute respiratory failure. British Thoracic Society Standards of Care Committee. *Thorax* 2002; 57: 192–211.]

<http://www.pacep.org/>

[Pulmonary artery catheter resource with haemodynamic monitoring tutorials. Free to use once registered.]

[http://www.sfar.org/s/article.php?id\\_article=60](http://www.sfar.org/s/article.php?id_article=60)

[This site has information on all the various scoring systems used in critically ill patients, including on-line calculators.]

<http://www.dicm.co.uk/papers.htm>

[This is a personal website aimed at those taking the Diploma in Intensive Care Medicine Exam. It claims to list the top 100 critical care references and succeeds in most areas.]

<http://www.ardsnet.org/>

[The ARDS clinical network site. This contains updates on ARDS studies performed by the network.]

## Chapter 6

# Anaesthetists and chronic pain

Anaesthesia is concerned with reducing sensation during surgery; it does not in itself cure patients but enables important treatment to take place without the experience of pain. This is achieved by the careful application of clinical physiology, pharmacology and therapeutics. With this expertise in pain and symptom control, some anaesthetists have specialized in the management of pain as a problem in its own right, leading to the establishment of modern pain relief clinics where they work with a team of nurses, physiotherapists and psychologists.

### The definition of pain

The International Association for the Study of Pain defines pain as:

‘An unpleasant sensory and emotional *experience* associated with actual or potential tissue damage or described in terms of such damage’.

Many interactions within the central nervous system, previous experiences and present emotional state will all determine the reactions to tissue injury.

The following are examples of this:

- *Effect of changed environment* A hospital admission where painful treatment is expected may result in an apparently minor stimulation, such as venepuncture, which may otherwise be tolerated, initiating an overwhelming state of distress.

- *Distraction* A kick on the shin during a game of football is likely to provoke very different pain behaviour when possession is maintained with a clear shot at goal compared to losing the tackle and with it the chance of victory!

- *Meaning of pain* In the previous example, the football injury and the sensations that go with it will have a positive meaning. A display of pain behaviour may bring about a reward, particularly for being brought down in the penalty area. Similar sensations in a cancer patient with a bone metastasis in the tibia may provoke anxiety, and fear of pain as yet another problem to be endured—certainly a negative meaning.

- *Significance of pain* The symptoms of headache, photophobia and vomiting in a medical student would normally result in presentation at the local casualty department with a self-made diagnosis of meningitis. Exactly the same symptoms would be ignored in the knowledge that he (or she) had drunk 10 pints of lager the night before! Thus pain behaviour is conditioned by knowledge and understanding.

- *Memory and culture of pain* Pain may leave a memory that will discourage repeating an action. Alternatively a response may be learned from observing the behaviour and attitudes of others. This can have both beneficial and detrimental effects. Cultural differences are important when treating patients of different nationality and race. Age is

important: children may not have the means to understand pain, or otherwise they express both pain and distress by crying. The elderly may be too ashamed to admit to needing help with pain.

## Acute versus chronic pain

### Acute pain

When injury has taken place, pain normally limits activity and promotes healing. The pain from a blister on the heel when wearing new shoes is a warning in an attempt to prevent more severe damage to the skin. A healing wound is guarded, preventing stress on newly formed connective tissues and the risk of wound breakdown. The region of the body surrounding the injury, even the whole limb, may also undergo change, becoming sensitive to even minor stimulation. The changes comprise:

- *hyperaesthesia*: increased appreciation of any stimulus;
- *hyperalgesia*: more intense appreciation of a painful stimulus;
- *allodynia*: sensation of pain in response to a normally non-painful stimulus.

They are mediated partly by locally released substances in the tissues (inflammation), but also by changes in the spinal cord processing of neuronal information. Hyperaesthesia, hyperalgesia and allodynia usually resolve as injuries heal. These protective and incapacitating functions are an acute response to trauma, surgery or acute illness.

### Chronic pain

This suggests persistence of the pain for a long time. There are several useful subdivisions:

- *Pain from continuing tissue damage* Rheumatoid arthritis pain is an example. Pain usually restricts movement and is useful in preventing further damage to the joint. In contrast, neuropathic joints that have lost sensation, for example in diabetes, degenerate rapidly.
- *Chronic benign pain (pain despite tissue healing)* The hyperaesthesia and allodynia of acute injury

may not resolve with healing of the tissues; in other words the protective mechanisms have not extinguished themselves. This may lead to confusion for both doctors and patients, with repeated attempts at surgical intervention which only exacerbate the problem (e.g. postsurgical back pain does not usually respond to further operations). Chronic benign pain can also occur without injury if hyperaesthesia and allodynia occur for reasons other than injury; a similar pain state will result as when injury is responsible.

- *Cancer pain (pain associated with a malignant tumour)* This is usually included as a chronic pain but it is best thought of as a combination of several acute pains from destructive effects of the tumour. Once established, even with treatment, pain is usually a feature of remaining life.

We live in a society with high expectations of medical intervention for injury and illness. Severe pain normally elicits sympathy and naturally we strive to relieve it whenever possible. Once severe pain is established, however, the resistance to further pain is reduced—the physiological pain threshold is lowered and normally innocuous stimuli may not be tolerated. Symptoms from mild degenerative conditions may be amplified. Prolonged illness or distress results in emotional changes, particularly depression of mood. The questioning of the severity of pain exacerbates depression in patients with chronic pain.

*To summarize:*

- Acute pain: the normal body responds to noxious stimuli with the experience of pain.
- Chronic pain: the sensitized nervous system responds more readily to both noxious and innocuous stimuli.

The remainder of this chapter considers the understanding, mechanisms and management of the pain problems seen in pain relief clinics.

## Mechanisms of pain generation

The following account separates pain mechanisms into distinct entities, but it must be remembered that in reality most pain results from activation of several mechanisms, such that the final experience is complex.

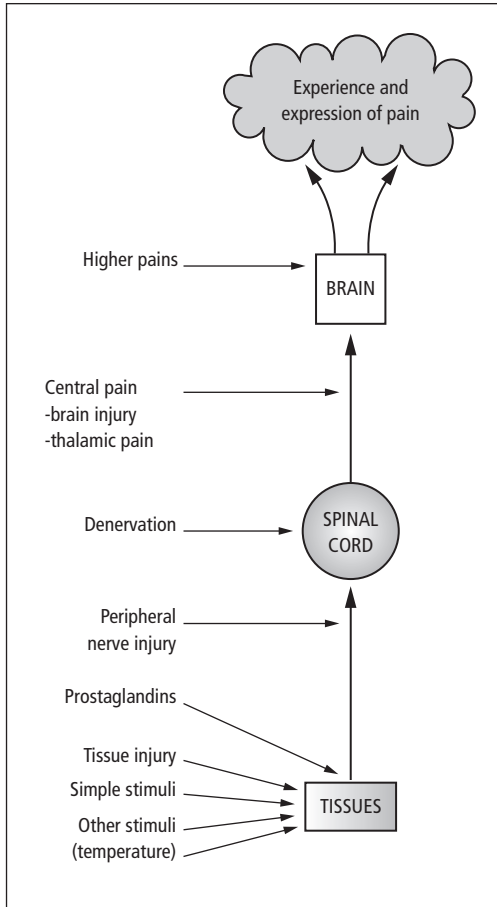

**Figure 6.1** Mechanisms of pain generation.

Pain may be generated in a number of ways (Fig. 6.1):

- *Simple stimulation* Normal activity causing stimulation of tissues can lead to pain; for example the sensation of pressure when maintaining an uncomfortable posture is relieved on shifting position. It is often subconscious and protects us from damage when attention may be focused elsewhere.
- *Tissue injury* This results in structural elements being damaged and an inflammatory response occurs. Many chemicals are released, including:
  - histamine;
  - bradykinin;

- 5-hydroxytryptamine (5-HT);
- hydrogen and potassium ions.
- *Prostaglandins* These sensitize nerve endings to react more intensely to further stimulation; for example a fingernail when hit with a hammer, although perhaps not showing signs of damage, is very sensitive to further touch and movement.
- *Other stimuli* Impulses from pain and temperature receptors are carried in similar small nerve fibres and the threshold for stimulation may be reduced at low temperatures. For example, arthritis patients commonly complain of increased pain during cold weather. It is not necessary for there to be tissue damage to elicit pain from the periphery; pathways may be stimulated by unusual stimuli: eating ice-cream too quickly often provokes an intense headache but is not usually perceived as a threat to bodily integrity!
- *Peripheral nerve damage* Damage to the nerves supplying an area of the body may result in pain. Peripheral nerves are not normally sensitive to mechanical stimuli, but attempts at regeneration within a damaged nerve may result in a neuroma that can be exquisitely tender. The pain will be referred to the area served by the nerve, although obviously there is no damage to the painful area.
- *Denervation* Pain may occur even when sensory receptors are absent, for example after amputation. Sensation can be attributed to an area of the body that does not exist because the brain still has a representation of the absent part (e.g. the painful 'phantom limb').
- *Central pain* Damage of the thalamic pathways which carry nociceptive information can lead to the experience of pain. As with many chronic pains, the problem is within the central nervous system and it rarely responds to conventional analgesia.
- *Higher pains* We have probably all suffered grief, perhaps the death of a loved relative or failure in an important examination. We describe this as painful and although the pain cannot be localized to a particular body part, it is nevertheless very real. This pain exists with no physical input to the body. The pain of a broken heart is no less real than the pain of a broken leg.



We all have the facility to experience excruciating pain from any part of the body and are prevented from this only by the normal functioning of our nervous system. Both noxious stimulation and disorders of transmission or perception have identical results—the experience of pain.

### The variability of pain

It can be seen that pain experience and expression can be triggered and conditioned by many factors other than peripheral noxious stimulation. The body is subjected to millions of stimuli each day; most are of no significance or threat and need to be filtered from entering consciousness or producing a response. The fact that responses to stimulation can vary in intensity according to factors both within and outside the body led Melzack and Wall to propose the Gate Control Theory of Pain (Fig. 6.2). It notes that:

- Sensory information from the periphery is carried to the spinal cord in large-diameter (pressure, touch and vibration) or small-diameter (pain and temperature) nerve fibres.
- An injury usually produces a brief, sharp ‘first pain’ via the large fibres that is well localized to the injury and produces withdrawal. A dull, aching ‘second pain’ transmitted by the smaller fibres follows after a fraction of a second and this is more prolonged.

- Both of these nerve types synapse onto central transmission neurones in the dorsal horn of the spinal cord (the substantia gelatinosa).
- Transmission is modified by inhibitory interneurons which are switched on by large-fibre input and off by small-fibre input.

This explains the effect of stimulation-induced analgesia: large-fibre input activating the inhibitory neurones reduces the input from smaller fibres. We are all familiar with this effect: when we suffer a minor injury, our instinct is to ‘rub it better’. This action stimulates large fibres with touch and vibration and thereby reduces the transmission of nociceptive information from the small fibres activated in the injury.

The Gate Control Theory is only one example of how the nervous system can modify in response to electrical and chemical activity in nerves. The brain also contributes by exerting ‘central control’ via the descending pathways of the spinal cord, thereby helping to explain how mood and behaviour affect processing within the spinal cord. The whole state is referred to as one of neuroplasticity that occurs in a changing matrix of electrical and neurotransmitter activity, rather than a simple fixed electrical circuit.

### Clinical assessment of chronic pain

The correct management of the patient with chronic pain is based upon the basic principles of

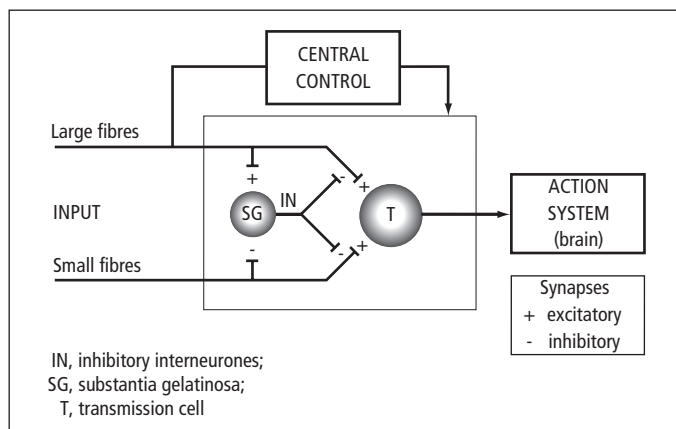

Figure 6.2 The gate theory of pain.



taking a full history and performing a physical examination prior to ordering investigations and initiating treatment. Chronic pain is a specific condition that must be recognized and treated, rather than a diagnosis of exclusion because nothing else will account for the pain. Patients' symptoms may previously have been dismissed—listening and understanding are as important as any prescription.

## History

- *Site* This may be obvious and related to a previous injury. Diffuse or non-dermatomal patterns of pain distribution are related to central sensitization and do not imply that the symptoms are not genuine. Pain may be felt in structures with common innervation (e.g. heart with left arm, leg with low back). Pain diagrams are helpful (Fig. 6.3).
- *Character* Some conditions are associated with pain of a particular nature. Lists of words have been

used to help patients choose a suitable description (e.g. the McGill pain questionnaire). Trigeminal neuralgia may be described as shooting, fibromyalgia as exhausting, burning and nauseating.

- *The pain history* Past treatment and investigations are often long and complex, and involve different hospitals and specialists. A complete history will include:

- the time-course of the pain;
- accentuating or relieving factors;
- the pattern of activity and relation to pain;
- the effect on sleep;
- previous and current treatment, including:
  - medications;
  - type and effects of physiotherapy;
  - aids and appliances;
  - alternative therapies tried;
- the effect on employment;
- financial support:
  - invalidity benefits;
  - pensions;
  - Disability Living Allowance, etc.;

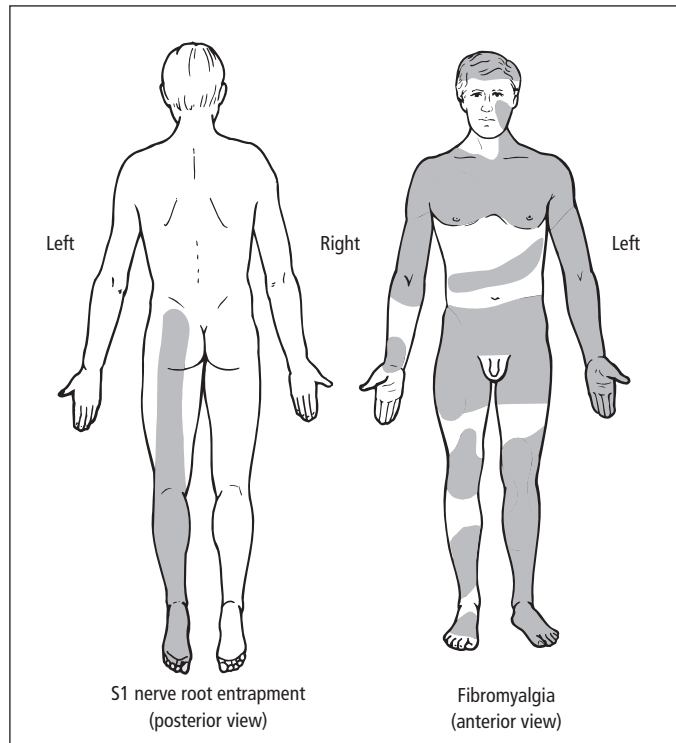

**Figure 6.3** Pain drawings showing the typical pain distribution resulting from an S1 nerve root compression (post view) compared with the pain experience of a patient with fibromyalgia (anterior view).

- social and family losses because of pain;
- concerns about the future;
- uncertainties about diagnosis and treatment;
- past medical history, including episodes of vague or unexplained illnesses;
- family history, which may reveal clues as to coping mechanisms and attitude to chronic illness within the family.

### Psychological assessment

An assessment of mood is important and frequently reveals evidence of depression. This may be related to the pain itself, but is also associated with frustration or anger at many previous attempts at treatment or the failure of treatment, lack of a clear diagnosis or disease, and loss of social and financial status. These are all common with chronic pain. The assistance of a psychologist is invaluable to explore emotional issues associated with, or caused by, the pain. Wherever possible, patients should be seen with a partner in order to assess independently the degree of physical and emotional disturbance at home and with the family. Depression is a normal human response to an uncertain future full of pain.

### Physical examination

It is unusual for patients to present with ‘put on’ symptoms of pain. Malingering is very rare. Often symptoms and the reaction to examination are exaggerated, but this is not surprising considering that most patients with years of suffering are likely to be distressed and anxious. Exaggeration may be to convince rather than to deceive. Most patients experience worse pain after even limited clinical examination.

Pain *may* be associated with the following structures:

- bones: deformity, tenderness;
- joints: swelling, tenderness, limitation of movement;
- nerves: function, swelling or tenderness over the course of a peripheral nerve;
- muscles: power and tone, localized or generalized tenderness;

- skin: signs of sympathetic dysfunction:
  - temperature change;
  - loss of hair growth;
  - vascular changes and discoloration;
  - disorders of sensation.

In addition, loss of confidence in movements, guarding and abnormal posture are noted as possible contributions to maintaining chronic pain.

Some patients have no physical signs despite severe symptoms—again this does not imply that the pain is not genuine.

### Measurement of pain

It is impossible to measure an experience directly so we rely on written or verbal self-report, as well as facial expression, body language and behaviour to assess pain. Surrogate measures such as the number of breakthrough analgesia tablets taken may be useful as a measure of pain or of the effectiveness of treatment. Psychological measures of coping, distress and depression are all valuable tools in exploring the pain; however, they should be interpreted carefully in conjunction with a clinical psychologist.

### Investigations

Patients with chronic pain have usually had many investigations and may be frustrated that nothing has been found. They may not understand that pain cannot be seen on their scans and X-rays. Care must be taken to explain that the absence of positive findings does not mean that the pain is in any way ‘imaginary’, ‘all in the mind’ or ‘psychological’. One danger of sensitive tests, such as MRI, is that abnormalities that are coincidental to the pain may be revealed—careful feedback of information is always required. Figure 6.4 demonstrates that disease does not always cause pain.

Some well-meaning explanations may increase anxiety. Using terms such as ‘crumbling spine’ or ‘degenerative changes’ in chronic low back pain may invoke fear for the future and a life of increasing disability, whereas in fact both back pain and the preferable term ‘age-related change’ are common and are not well correlated.

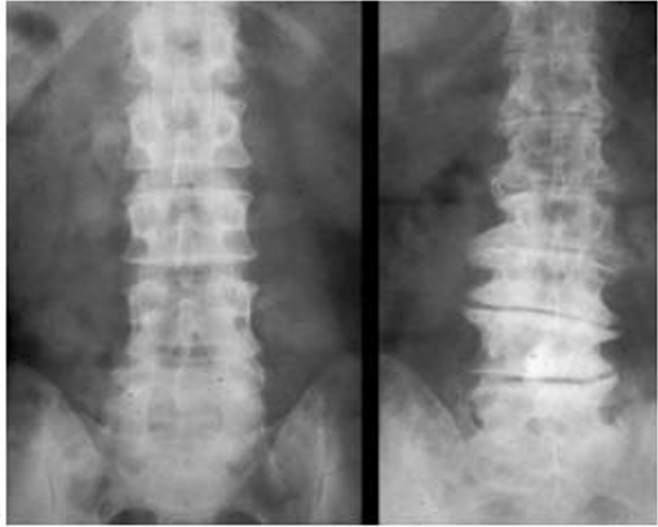

**Figure 6.4** X-rays of lumbar spine. The patient on the left had been confined to bed for 2 years with back pain; the patient on the right had never had a day's back pain in her life.

## Treatment of chronic pain

There are very few effective 'cures' for chronic pain problems. Intervention is only appropriate if there is a realistic chance of success—an honest opinion is appreciated. For some conditions associated with ongoing tissue damage, such as rheumatoid arthritis, it is possible to suppress the inflammation and the associated pain. This may not be completely successful, so the treatment of pain may have to proceed alongside treatment of the condition.

## Pharmacological treatments

### Opioids

Morphine is commonly used in the management of acute pain and has a major role in control of chronic pain. In the latter, it is frequently taken orally; the dose might start at 10 mg every 4 h, but eventually range up to 2000 mg per 24 h in some patients. Large daily doses are conveniently given as a long-acting sustained-release preparation once or twice a day depending on the formulation. Additional breakthrough doses of morphine solution or immediate release tablets, usually 10% of the total daily dose, are made available for extra or in-

cident pain, and the amount of this that is taken can be used as a guide for increasing the long-acting preparation.

Respiratory depression (often a feared complication) is not seen, even with very high doses, provided that doses are increased in a stepwise fashion—for example by 30% increments according to effect. Sedation may be a problem for some patients but with careful titration it can be minimized. Increased doses of opioids can produce sedation and calming effects at the end of life that may be very useful. Alternative potent opioids are:

- *diamorphine (heroin)*: used for subcutaneous infusions as it is more soluble than morphine and can be dissolved in a smaller volume for administration using a compact pump.

- *fentanyl*: absorbed from a patch applied to the skin and changed every 3 days. Useful because it avoids the oral route and popular with patients because it avoids needles. May have reduced side-effects compared with morphine.

- *methadone*: inexpensive and has a long plasma half-life; may be given as a once daily dose orally.

- *oxycodone and hydromorphone*: alternative opioids to morphine, usually given orally, with fewer side-effects in some patients.

Less potent opioids such as dextropropoxyphene (combined with paracetamol in coproxamol),

tramadol, codeine or dihydrocodeine are commonly prescribed for chronic pain. They have the same effects and side-effects as morphine but the maximum analgesic effect is limited.

There is no doubt that the proper (generous) use of opioids in cancer pain has revolutionized remaining life for cancer patients. Debate continues, however, about the use of opioids in chronic benign pain (such as low back pain). Modest doses of opioids continued on a regular prescription with careful monitoring of dose and effect appear to be safe and very helpful for some patients, especially if other physical and psychological treatments are made available.

### **Non-steroidal anti-inflammatory drugs**

NSAIDs are often used alone or in combination with opioids, particularly where there is inflammatory or bone pain. Their mechanism of action and side-effects are discussed on page 40. A wide range of both non-specific and COX-2 inhibitors are available; the latter are preferable for long-term use in vulnerable groups, for example the elderly and those on steroids.

### **Tricyclic antidepressants**

The mechanism of action is thought to be due to the potentiation of serotonin and noradrenaline in the CNS. Amitriptyline is the most commonly used drug, and has been used extensively to treat neuropathic pain. The sedative effect may be useful for sleep disturbance where this is a problem. The antidepressant effect may be an additional benefit. Newer antidepressants with fewer anticholinergic side-effects are not as useful for chronic pain.

### **Anticonvulsants**

Carbamazepine, phenytoin and, more recently, gabapentin have been shown to be useful for pain associated with nerve damage and are now also often tried for other pain syndromes where there may be sensitization of the central nervous system. Trigeminal neuralgia, denervation of the upper limb following avulsion of the brachial plexus and

postherpetic neuralgia (PHN) are all examples of pain syndromes that may respond to anticonvulsants.

### **Steroids**

These are often injected into joints or tendon sheaths for arthritis or inflammatory pain, but are not generally indicated for chronic benign pain because of the risk of osteoporosis and gastric ulceration. Injections of steroid into the epidural space may be tried when nerve roots are thought to be compressed or inflamed: the benefit may be due to a reduction in nerve root oedema. There may be a useful reduction in swelling and compression from solid tumours associated with improved appetite and well-being in cancer patients.

### **Capsaicin**

Applied topically as a cream, this extract of the chilli pepper can depress C-fibre nerve function. It has been found useful in cutaneous pain problems such as scar pain and postherpetic neuralgia. It produces a burning sensation, so may be used with a topical local anaesthetic.

## **Non-pharmacological interventions**

(Fig. 6.5)

### **Nerve blocks**

These may be performed on any nerves thought to be part of the pain pathway and may help in the understanding of the contribution of peripheral input to the overall pain. Sometimes simple nerve blocks with local anaesthetic give prolonged relief, perhaps by reducing central sensitization. Attempts to make blocks permanent with neurolytic agents (alcohol or phenol) often result in worse pain, as central neurones lose peripheral inhibitory input and become spontaneously active or respond to previously non-painful stimuli from other pathways (allodynia). Indwelling epidural or intrathecal catheters delivering local anaesthetic or opioid can provide sustained analgesia, for

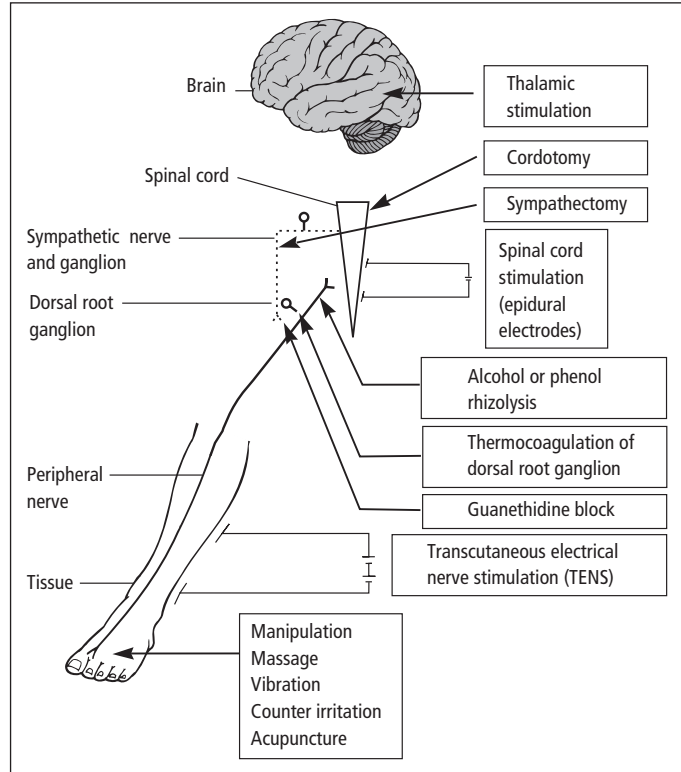

**Figure 6.5** Non-pharmacological methods of providing analgesia.

example in severe and otherwise uncontrollable cancer pain.

Damaged peripheral nerves are very sensitive to noradrenaline, so reducing sympathetic activity may be helpful. Guanethidine intravenous regional block or cervical or lumbar sympathetic chain blocks with local anaesthetic may help. The latter can be performed with phenol and is a useful treatment for the pain and ischaemia of peripheral vascular disease.

The spinothalamic tracts carry nociceptive information from the contralateral side of the body, and may be interrupted at the level of the cervical spine by a cordotomy (cutting the cord) performed surgically at open operation or percutaneously with a radio-frequency heated lesion-generating needle. Fortunately this is rarely necessary because the other techniques are usually effective.

### Stimulation

Stimulation of the nervous system appears to be an effective method of decreasing some pains. Massage may be temporarily helpful, but electrical stimulation using electrodes on the skin (transcutaneous electrical nerve stimulation (TENS)), or in the epidural space (spinal cord stimulation) may enable continued benefit. Acupuncture involves identifying and needling specific points on the body surface according to patterns determined by traditional Chinese medical practice. The stimulation is thought to reinforce intrinsic or natural analgesia.

### Manipulation

The aim is to restore movement and function. Osteopathy and chiropractic techniques are com-

monly sought by patients for chronic musculoskeletal pain, usually following unsuccessful conventional treatment. The Alexander Technique or yoga offer self help for motivated patients.

## Physiotherapy

Physical structure and function, which often become abnormal as a result of chronic pain, can be assessed by physiotherapists. Confidence needs to be rebuilt and patients encouraged to exercise despite pain in order to restore activities.

A strong painful body is better than a weak painful body.

## Psychology

It is unusual for patients to present with chronic pain without distress or depression. This is often as a result of the frustration of limited activity and many failed attempts at treatment. Psychologists are essential in helping to overcome these problems. Common obstacles to coping with chronic benign pain are:

- fear of not being believed: patients often have nothing to show for their pain;
- fear of deterioration and dependency;
- failure to accept that the pain is permanent;
- anger directed at the cause of the pain, for example a road traffic accident causing whiplash injury to the cervical spine;
- guilt at not being able to fulfil perceived role: letting others down because of the pain;
- side-effects of unhelpful medical treatments, for example sedative effects of benzodiazepines.

Careful assessment and treatment using cognitive-behavioural methods need to be more widely available.

## Pain management programmes

Many patients with chronic benign pain can be helped by a team of medical, physiotherapy and psychology therapists working together to address many of the above physical and psychological issues. The aim is to develop understanding and provide useful coping strategies such as pacing and

relaxation, with the object of helping the patient to return to useful function with less impact from the persistent pain.

## Specific chronic pain problems

### Neuropathic pain (postoperative pain)

Although usually acute and self-limiting, postoperative pain may progress to chronic pain. Peripheral nerve damage is one cause; for example post-thoracotomy intercostal nerve damage or ilio-inguinal nerve damage from inguinal hernia repair. Both are surprisingly frequent, persistent and troublesome, requiring a wide range of treatments.

### Postherpetic neuralgia (PHN)

PHN is a common consequence of infection with the herpes zoster virus, with damage to the sensory nerve cells in the dorsal root ganglion. The painful crusted lesions on the skin (on the dermatome corresponding to the infected nerve) heal after several weeks but the site often has persistent abnormal sensation, with light touch producing pain (allodynia). Antiviral agents, applied topically or systemically during the initial infection, may limit nerve damage and subsequent neuralgia, and early sympathetic blocks may be of benefit, for example stellate ganglion or lumbar sympathetic blocks.

### Phantom limb pain

Normal sensory input from the periphery is necessary for the proper regulation of nerves in the CNS—loss after amputation may still result in activity of the central nerves that originally represented the amputated part. Phantom sensation is very common and may include pain. It is one of the most challenging conditions to treat and there are many potential treatments available.

### Neuroma

Regeneration of damaged peripheral nerves may result in tender neuromata that are very painful

spontaneously or with pressure. They are a particular problem if compressed by a prosthesis and may then have to be surgically resected or repositioned.

### **Complex regional pain syndrome (previously known as reflex sympathetic dystrophy)**

Sometimes the neuronal processes of acute pain (see page 140) do not extinguish themselves after an injury and when tissues have apparently healed. This results in continued sensitivity and pain. The condition may progress, with signs of severe tissue inflammation and later atrophy. The pathophysiology is not fully understood but it can be a severe and very disabling problem. Early mobilization appears to be important in preventing progression and analgesia is provided to encourage this. Specific treatment may involve sympathectomy.

### **Trigeminal neuralgia**

Many cases are thought to be caused by vascular compression of the trigeminal nerve as it emerges from the pons in the posterior fossa—in fit patients, surgical decompression may be considered. In others, anticonvulsant medication or injection of the trigeminal ganglion with phenol or glycerol is usually effective.

### **Arthritis**

In this debilitating condition, pain is a frequent symptom of joint inflammation and destruction. Most patients are managed by general practitioners or by rheumatologists. Patients with severe arthritis have visible deformity and disability, which leads to their suffering and pain being understood by others and it is often well tolerated. NSAIDs and opioids are usually effective when used in addition to specific therapy for the disease.

### **Back pain**

More than half the population will suffer back pain at some time in their lives. With advancing age,

spinal degenerative changes are common, but these changes do not correlate well with back pain symptoms. Unfortunately, treatment is not available for most degenerative changes—there is little evidence that replacing worn discs or fusing spinal segments has long-term beneficial effects. Most important is early exclusion of specific causes of back pain. These are:

- prolapsed intervertebral disc with spinal cord or nerve root compression;
- tumour of bone, meninges or nerves;
- infection of the spine.

New episodes of back pain should be properly investigated and the patient reassured if appropriate. Early mobilization and activity are important to prevent dysfunction and guarding of movements of the back. Even 2 days of bed rest may be harmful. Most patients are given advice to rest until the pain subsides, and investigation is undertaken only after a long delay. This leads to unnecessary suffering and dissatisfaction with the medical profession. Treatment involves acknowledging the pain, education, gradual return to activity under strict supervision and the introduction of coping skills for pain.

### **Fibromyalgia**

A generalized disorder of pain sensation probably related to abnormal central neuronal activity. It involves widespread tenderness accompanied by sleep disturbance, fatigue and, not surprisingly, depression. Most common in women in their middle years and associated with other pain problems such as migraine and irritable bowel syndrome. Patients benefit most from explanation and reassurance. Amitriptyline may help restore more normal sleep.

### **Cancer pain**

Cancers involving destruction of tissue are painful. Two-thirds of patients with cancer as a terminal illness have significant pain. Modern chemotherapy, radiotherapy and surgery can reduce the growth of tumour, but pain may persist even despite technically successful therapy. Pain may be feared more

than death itself. Symptoms can become overwhelming—a mixture of pain, fear, depression, panic and denial—the so-called ‘total pain syndrome’.

Unfortunately morphine is not easily available for clinical use in many developing countries. Even in Western countries, use is inadequate due to fear of side-effects. Large doses of morphine may be required (compared to those used to treat acute pain), but when correctly used it is safe and effective for most cancer pain.

It is always possible to do something for cancer pain, and it may be reassuring for patients to know that there are alternative treatments should their symptoms progress.

## The chronic pain syndrome

The precise cause and mechanism of many pain syndromes remains unknown. Many chronic pain-clinic patients have the following characteristics:

- a long history;
- many consultations;
- multiple negative investigations;
- a high incidence of functional disturbance, for example headache, irritable bowel syndrome;
- few standard physical findings;
- distress;
- depression.

Medicolegal proceedings are common but only rarely result in deliberate exaggeration of symptoms. The medical examination of these patients requires experience and understanding of the context in which the pain is being experienced. Even experienced clinicians have been known to accuse these patients of malingering.

Patients may have coped well with the pain for a long period of time—it is usually a series of events as a consequence of the pain that precipitates referral. Measures aimed at dealing with the pain may be useless if, for example, the patient has become depressed, is dependent on medication, has lost his or her employment and self-respect, and has been accused of malingering. Treatment is

aimed at coping with pain, which in turn depends on:

- understanding that chronic pain is harmless (but painful);
- stopping looking for a cure;
- accepting some limitations;
- knowing that nothing is being hidden;
- a willingness to change (that effort is required).

## Preventing chronic pain

It may be possible to prevent chronic benign pain by more aggressive treatment of acute pain. Identification of risk factors, early education and discussion may help to prevent the loss of function and frustration that often lead to chronic pain.

## Useful websites

<http://www.jr2.ox.ac.uk/bandolier/booth/painpag/>

[The Oxford Pain website. An excellent site for the latest evidence-based reviews in pain.]

<http://www.theacpa.org/resources/ACPAdrugssupplement2003.pdf>

[The American Chronic Pain Association guide on drugs used in chronic pain. Although primarily aimed at patients, it is full of useful information and links to other sites.]

<http://www.nysora.com/>

[This is the best website for information about regional anaesthesia techniques.]

<http://www.painsociety.org/>

[The UK Pain Society website gives guidance on UK practice.]

<http://www.iasp-pain.org/index.html>

[The International Association for Study of Pain (IASP), giving guidance on international practice.]

[http://www.ninds.nih.gov/health\\_and\\_medical/disorders/chronic\\_pain.htm](http://www.ninds.nih.gov/health_and_medical/disorders/chronic_pain.htm)

[The National Institute of Neurological Disorders and Stroke chronic pain homepage.]



# Index

Page numbers in *italics* refer to figures and those in **bold** to tables; note that figures and tables are only indicated when they are separated from their text references.

- ABC of resuscitation
  - adult basic life support 99–102
  - critically ill patients 117–22
  - paediatric basic life support 108–10
  - perioperative emergencies 90
- abdominal surgery, upper 81
- activated protein C (APC) 136–7
- acupuncture 147
- Acute Life-threatening Event
  - Recognition and Treatment (ALERT) 113
- acute renal failure 127, 135–6
- acute respiratory distress syndrome (ARDS) 129, 133
  - prone ventilation 134
  - pulmonary arterial vasodilator therapy 133
- acute tubular necrosis (ATN) 127
- Addison's disease 9
- adrenaline *see* epinephrine
- advanced life support (ALS) 103–8, 113
- advanced paediatric life support (APLS) 113
- advanced trauma life support (ATLS) 113
- air, medical 41
- air embolus 57
- airway adjuncts, simple 18, 117–18
- airway assessment
  - critical illness 117
  - preoperative 6, 7, 8
- airway management 17–27
  - acute severe allergic reactions 91
  - basic life support 99–100
  - basic techniques 17–18
  - critical illness 117–18
  - emergency techniques 27
  - local anaesthetic toxicity 63
  - paediatric basic life support 108
  - problems 18–19
  - recovery room equipment 71
  - see also* laryngeal mask airway; tracheal intubation
- airway obstruction 94–5
  - anaesthetized patient 95
  - basic life support 99–100, 108
  - causes **117**
  - conscious patient 94
  - critical illness 117–18
  - postoperative 72
  - unconscious patient 94, 95, 117–18
- airway pressure, monitoring 53
- albumin solution **59**
- alcohol consumption 5
- aldosterone 80
- Alexander technique 148
- alfentanil **38**
- allergic reactions, acute severe 90–1
- allergies, history 5
- allodynia 140
- alpha-agonists 68
- alveolar hypoventilation 72–3
- alveolar ventilation
  - inhalational anaesthesia 32
  - monitoring 51
- American Heart Association 3
- American Society of Anesthesiologists (ASA)
  - difficult airway guidelines 111
  - physical status scale 10
- amethocaine, topical 62
- aminophylline 91, 95
- amiodarone 78, 107, 134
- amitriptyline 146
- amnesia 15
- anaesthesia 15–70
  - airway management 17–27
    - defined 62
    - induction 27
    - maintenance 29–33
    - measurement and monitoring 47–54
    - premedication 15–17
    - previous history 4–5
    - risk 9–12
    - safe delivery 40–7
    - stages 29
    - useful websites 69–70
- anaesthetic assessment *see* preoperative assessment
- anaesthetic breathing systems *see* breathing systems, anaesthetic
- anaesthetic drugs 27–40
  - allergic reactions 90, 91
  - inducing hypotension 97
- anaesthetic gases *see* inhalational anaesthetics
- anaesthetic machine 42–3
  - checking 43
  - oxygen failure alarm 42, 53
- analgesia
  - chronic pain 145–8
  - defined 62
  - ICU patients 130–1
  - non-pharmacological methods 146–8
  - patient-controlled (PCA) 84–5
  - postoperative *see* postoperative analgesia
- analgesic drugs
  - for anaesthesia 37–40
  - chronic pain 145–6
  - postoperative 82–3
  - premedication 16
  - sites of action 83
- anaphylactic reaction 90, 91
- anaphylactoid reaction 90, 91
- antacids 15–16
- antecubital fossa
  - central venous cannulation via 58
  - veins 54–5
- antibiotics
  - allergic reactions 90
  - ICU patients 133
  - preoperative 17
- anticholinergic agents 16, 79
- anticholinesterases 35
- anticoagulant therapy 9, 17
- anticonvulsants 146
- antidiuretic hormone (ADH) 80
- anti-emetic drugs 78–9
  - preoperative 15, **16**
  - spinal anaesthesia 69

## Index

- antihistamines 78, 91  
anxiety 81  
anxiolysis 15  
aortic stenosis 8  
ARDS *see* acute respiratory distress syndrome  
arrhythmias  
    critically ill patients 122, 124, 134  
    induced by tracheal intubation 25  
    management 77–8  
    postoperative 77–8  
    preoperative assessment 3, 6, 9  
    suxamethonium-induced 34  
arterial line, indwelling 52, 124–5  
arthritis 149  
aspiration of gastric contents  
    91–3  
    management 92  
    prevention 26, 92–3  
    risk factors 17, 91–2  
    before tracheal intubation 25  
assessment, preoperative *see* preoperative assessment  
Association of Anaesthetists of Great Britain (AAGBI) 69, 111  
    checklist for anaesthetic machines 43  
    monitoring recommendations 49, 53–4  
asthma  
    acute severe 95–6, 111  
    allergic drug reactions 90  
    NSAIDs and 40  
    preoperative assessment 4, 9  
asystole 104, 107  
atelectasis, postoperative 73  
atenolol 16  
atracurium **36**  
atrial fibrillation 77–8, 122, 134  
atropine  
    bradycardias 68, 78, 97  
    cardiac arrest 107  
    nausea and vomiting 68, 79  
    neuromuscular blockade reversal 35  
    preoperative 16  
back pain, chronic low 144, 145, 149  
basic life support (BLS) 99–103  
    airway control 99–100  
    breathing 100–1  
    circulation 101–2  
    common errors 102–3  
    healthcare professional 103  
    layperson 99  
    paediatric 108–10  
    patient evaluation 99  
basilic vein 54, 55, 58  
benzodiazepines 15  
beta-agonists 68, 95  
beta blockers 15, 16, 77  
Bier's block 65  
bleeding diatheses 9  
blood  
    components 60  
    predeposition 60  
    whole 60  
blood loss  
    monitoring during anaesthesia 53  
    volume replacement 61, 80  
    *see also* fluid losses  
blood pressure  
    critically ill patients 120–1, 124–5  
    invasive or direct monitoring 52, 120, 124–5  
    monitoring during anaesthesia 50, 52  
    *see also* hypertension; hypotension  
blood products 60  
blood transfusion 60, 80  
bougie, gum elastic 26  
brachial artery 54–5  
brachial plexus block 65  
bradycardia **122**  
    complicating spinal anaesthesia 68  
    postoperative 77, 78  
    profound 97  
breathing  
    assessment 100, 118  
    basic life support 100–1  
    critically ill patient 118–20  
    local anaesthetic toxicity 63  
    noisy 72, 117  
    paediatric basic life support 108–9  
    recovery room equipment 71  
    rescue 100–1  
breathing systems, anaesthetic  
    43–4  
    circle system 43–4, 45  
    components 43, 44  
    disconnection indicators 51, 53  
    monitoring correct functioning 53  
breathlessness 95  
bronchiectasis 9  
bronchodilators 133  
bronchoscopy, fiberoptic 26  
bronchospasm 90, 92  
bupivacaine **62**, 64  
    epidural anaesthesia 66, 87  
    hyperbaric 67  
Calder test 6  
cancer pain 140, 146, 149–50  
cannulae, peripheral intravenous  
    55  
    fluid flow 58–9  
    internal diameter 58, 59  
    length 58  
    over needle 55  
    shearing 57  
capnography  
    during anaesthesia 51, 53  
    to confirm tracheal tube position 25  
    website 70  
capsaicin, topical 146  
carbamazepine 146  
carbon dioxide (CO<sub>2</sub>)  
    absorber 43, 44, 45  
    arterial partial pressure (PaCO<sub>2</sub>) 46, 51, 118  
    cylinders **41**  
    end-tidal 25, 51  
carboxyhaemoglobin 51  
cardiac arrest 99–110, 116  
    advanced life support 103–8  
    basic life support 99–103  
    Universal Algorithm 105  
    useful websites 111  
    warning signs 116–17  
cardiac compressions  
    external 102  
    paediatric patients 109–10  
    open chest 108  
cardiac output  
    end-tidal CO<sub>2</sub> measurement 51  
    ICU monitoring 125, 126, 134  
    inhalational anaesthesia 32  
    low fixed, regional anaesthesia and 69  
    reduced 97, 120  
    targets in ICU patients 134–5  
cardiogenic shock 121–2  
cardiopulmonary resuscitation (CPR) 99–110  
    infants and children 108–10  
    useful websites 111  
    *see also* advanced life support; basic life support  
cardiorespiratory arrest 116  
cardiovascular disease  
    medical referral 9  
    preoperative assessment 3, 6  
cardiovascular failure 134  
cardioversion 78, 106, 107

- Care of the Critically Ill Surgical Patient (CCrISP) 113
- carotid artery pulse 102, 109
- catheters
- central venous 58
  - over needle 58
  - terminology 55
  - through needle 58
- cell savers 60
- central nervous system (CNS) disease 69
- central neural blockade 64
- complications 68
  - see also* epidural
    - anaesthesia/analgesia;
    - spinal anaesthesia/analgesia
- central pain 141
- central venous cannulation 57–8
- complications **58**
  - equipment 58
  - routes 58
  - uses **125**
- central venous pressure (CVP) factors affecting **53**
- ICU monitoring 125–6
  - monitoring during anaesthesia 52–3
  - postoperative monitoring 76–7, 80
- cephalic vein 54
- cerebral haemorrhage 72
- cerebral ischaemia 72
- cervical spine X-ray 8
- chest compressions, external
- adult 102
  - infants, children 109–10
- chest drain 96
- chest X-ray
- acute severe asthma 95
  - after central venous cannulation 58
  - preoperative 7–8
- children
- basic life support 108, 109–10
  - see also* paediatric patients
- chiropractic techniques 147–8
- chlorpheniramine 91
- chronic obstructive pulmonary disease (COPD)
- critical care 118–20, 132–3
  - preoperative assessment 4, 9
- chronic pain 139–50
- benign 140
  - clinical assessment 142–4
  - history 143–4
  - investigations 144, 145
  - physical examination 144
  - postoperative pain intensity and 81
  - prevention 150
  - psychological assessment 144
  - specific problems 148–50
  - treatment 145–8
  - vs* acute pain 140
- chronic pain syndrome 150
- circle system 43–4, 45
- circulation
- acute severe allergic reactions 91
  - assessment 101–2, 120
  - basic life support 101–2
  - critically ill patient 120–2
  - local anaesthetic toxicity 63
  - paediatric basic life support 109–10
  - recovery room equipment 71
  - severe hypotension 97
- clinic, preoperative assessment 2
- clotting tests **8**, 61
- coagulopathy, regional anaesthesia 69
- co-codamol 83
- codeine 83, 146
- colloids 59–60
- complex regional pain syndrome 149
- complications, postoperative 72–9
- conduction defects 3
- Confidential Enquiry into Perioperative Deaths (CEPOD) 9–10, 12
- congenital heart disease 9
- consent 12–13
- defined 12
  - information required 13
  - obtaining 13
  - unconscious patient 12
  - useful websites 14
  - written evidence 13
- continuous arteriovenous haemofiltration (CAVH) 135
- continuous positive airways pressure (CPAP) 119, 120
- continuous venovenous haemofiltration (CVVH) 135
- controlled drugs 39–40
- convulsions, local anaesthetic toxicity 63
- cooling measures 98
- COPD *see* chronic obstructive pulmonary disease
- coproxamol 145–6
- cordotomy 147
- coronary care unit (CCU) 116, 122, 123
- corticosteroids *see* steroids
- creatinine clearance (CL<sub>CR</sub>) 127
- cricoid pressure 26
- cricothyroidotomy
- needle 27, 28, 94
  - surgical 27, 29
- critical care 112–38
- integrated approach 112, **113**
  - levels **113**
  - organization 112
  - outreach teams 115
  - training and education 112–13
  - useful websites 137–8
  - see also* intensive care unit
- critical illness
- clinical scoring systems 113–15
  - definition and causes 115–16
  - initial assessment and management 116–22
- cryoprecipitate 60
- crystalloids 59
- cultural differences, pain response 139–40
- Cushing's disease 9
- cyanosis 72, 95, 118
- cyclizine **16**, 78
- cyclo-oxygenase (COX) inhibitors 40
- cyclo-oxygenase type 2 (COX-2) inhibitors 40, **85**
- cylinders, medical gas 41
- dantrolene 98, 99
- day case surgery 2
- dead space, ventilation 72
- defibrillation 106–7
- safety 106
  - synchronized 107
  - technique 107
- defibrillators, automated external (AEDs) 106
- denervation pain 141
- depression 144, 148
- desflurane **31**, **32**
- dexamethasone 79
- dextropropoxyphene 145–6
- diabetes 4, 9
- dialysis, ICU patients 135
- diamorphine
- chronic pain 140
  - epidural anaesthesia 87
  - see also* morphine
- diaphragmatic splinting 73
- diazepam 15, 63
- dihydrocodeine 146
- distraction 139

## Index

- diuretics 76–7  
dobutamine 9, 122, 134  
domperidone 79  
do not attempt resuscitation (DNAR) orders 116–17  
dopamine antagonists 78–9  
dorsal metacarpal veins 54  
drug abuse 5, 39  
drug history 5  
drugs  
  acute severe reactions 90–1  
  anaesthetic *see* anaesthetic drugs  
  controlled 39–40
- ECG *see* electrocardiogram  
echocardiography 8–9  
  stress 9  
  transoesophageal (TOE) 127  
education, critical care 112–13  
elective surgery 12  
  failed intubation 93  
  preoperative starvation 17  
electrical stimulation, chronic pain 147  
electrocardiogram (ECG)  
  during anaesthesia 49–50  
  cardiac arrest 106, 107  
  critically ill patients 122, 124  
  preoperative 7, **8**  
emergencies, perioperative 90–111  
emergency surgery 12  
  failed intubation 93  
EMLA (eutectic mixture of local anaesthetics) 17, 62  
emphysema 4  
endocrine disorders 9  
endotoxin 136  
enflurane **31, 32**  
enteral feeding 131, 132  
Entonox 32, **41, 88**  
epidural abscess 88  
epidural anaesthesia/analgesia 64, 65–7  
  chronic pain 146–7  
  complications 77, 87–8  
  contraindications 69  
  ICU patients 131  
  postoperative 86–8  
epidural blood patch 68  
epilepsy 4  
epinephrine (adrenaline)  
  allergic reactions 91  
  cardiopulmonary resuscitation 107  
  local anaesthesia 62–3  
etomidate **30, 33**
- eutectic mixture of local anaesthetics (EMLA) 17, 62  
evaporation, intraoperative fluid loss 61  
examination, physical  
  chronic pain 144  
  preoperative 5–6  
exercise tolerance 4  
expiratory valve 43  
expired-air ventilation 100–1  
  paediatric patients 109  
extravasation, fluid or drugs 57  
eye injuries, penetrating 34
- facemasks 18  
  oxygen delivery 74–5  
  problems 19  
  technique of holding 17, 18  
family *see* relatives  
family history 5  
fasting, preoperative 17  
fentanyl **38, 82**  
  chronic pain 145  
  epidural anaesthesia 67, 87  
fibrinogen levels 61  
fibromyalgia 149  
finger sweep technique 100, 108  
flowmeters, anaesthetic machine 42
- fluid  
  flow through cannulae 58–9  
  intraoperative requirements 61  
  intravenous 59–60  
  viscosity 58  
fluid administration 54–61  
  critical illness 121–2  
  intraoperative 60–1  
  postoperative 76, 77, 79–80  
  maintenance requirements 79  
  major surgery 79–80  
fluid challenge 52, 76, 121, 134  
fluid losses  
  accrued perioperative 60–1  
  intraoperative causes 61  
  postoperative 76, 80  
  third space 61, 80  
  *see also* blood loss  
fogging 25  
forced expiratory volume in 1s (FEV<sub>1</sub>) 8  
forceps, Magill's 22, 24  
forearm, veins 54, 55  
foreign bodies, inhaled 95, 101, 108  
fresh frozen plasma (FFP) 60  
frusemide 76–7  
full blood count (FBC) **8**
- functional residual capacity (FRC) 73, 129
- gabapentin 146  
gases  
  anaesthetic *see* inhalational anaesthetics  
  anaesthetic breathing systems 43–4  
  anaesthetic machine 42–3  
  delivery to operating theatre 40–2  
gastric emptying, delayed 17  
gastric ulcers, critically ill patients 132  
gastrointestinal tract  
  fluid losses 61  
  ischaemia 116  
gastro-oesophageal reflux 4, 17  
gate control theory of pain 142  
Gelofusine **59**  
general anaesthesia, drugs used 27–40  
Glasgow Coma Scale (GCS) 128  
glomerular filtration rate (GFR) 127  
gloves 56  
glucose, blood (BS)  
  control in critical illness 137  
  intraoperative 53  
  preoperative testing 7, **8**  
glucose solutions **59, 61**  
glyceryl trinitrate (GTN), transdermal 17  
glycopyrrolate 16, 35  
Goldman Cardiac Risk Index 10, **11**  
guanethidine intravenous regional block 147  
Guedel (oropharyngeal) airway 18, 19  
gum elastic bougie 26
- Haemacel **59**  
haematological disorders 9  
haematological tests 7, **8**  
haematoma  
  after peripheral vein cannulation 57  
  vertebral canal 87–8  
haemodilution, preoperative 60  
haemofiltration, continuous 135–6  
haemoglobin concentration 61  
haemoglobinopathies 9  
haemolytic anaemias 9  
haemorrhage 76, 97  
  *see also* blood loss  
haemothorax 73

- halothane **31, 32**  
 hepatitis 33  
 malignant hyperpyrexia 98  
 previous exposure 5  
 hand, veins of dorsum 54  
 Hartmann's solution **59, 61**  
 headache, postdural puncture 68  
 head injury 123, 128  
 head position, oral tracheal  
 intubation 24  
 head tilt plus chin lift 99, 100  
 paediatric patients 108  
 heart block **122**  
 heartburn 4  
 heart failure  
 monitoring during anaesthesia  
 52–3  
 preoperative assessment 3, 6, 9  
*see also* left ventricular failure  
 heart rate  
 critically ill patient 120–1  
 monitoring during anaesthesia  
 50  
*see also* bradycardia; tachycardia  
 hepatic function, ICU patients  
 128  
 hepatitis, halothane 33  
 hepatitis B 60  
 heroin *see* diamorphine  
 hiatus hernia 17  
 high airflow oxygen enrichment  
 (HAFOE) 75  
 high dependency unit (HDU)  
 112, **113**, 123  
 histamine release 34, **36**, 90, 97  
 history taking  
 chronic pain 143–4  
 preoperative 3–5  
 HIV infection 60  
 hormone replacement therapy  
 (HRT) 5  
 hospital-acquired infections 116,  
 132  
 Hudson mask 75  
 with reservoir 75  
 hydrocortisone 91, 95  
 hydromorphone 145  
 5-hydroxytryptamine 3(5-HT<sub>3</sub>)  
 antagonists 78  
 hygiene standards, ICU **132**  
 hyoscine 16, 79  
 hyperaesthesia 140  
 hyperalgesia 140  
 hyperbaric solutions 67  
 hypercapnia  
 permissive 133  
 postoperative 72  
 hyperpyrexia, malignant *see*  
 malignant hyperpyrexia
- hypertension  
 intubation induced 25  
 postoperative 78  
 preoperative assessment 2, 3, 6,  
 9  
 hyperthyroidism 9  
 hypopituitarism 9  
 hypotension  
 causes in critically ill **121**  
 complicating epidural analgesia  
 87  
 complicating spinal anaesthesia  
 68  
 postoperative 75–8  
 severe 96–7  
 hypothermia, postoperative 72  
 hypothyroidism 9  
 hypoventilation, alveolar 72–3  
 hypovolaemia 76, 97  
 critically ill patients 121, 134  
 epidural or spinal anaesthesia  
 69  
 management 76  
 hypoxia/hypoxaemia  
 acute severe asthma 95  
 COPD 118–20  
 critical illness 118  
 diffusion 33, 74  
 management 74  
 mechanical ventilation 129  
 postoperative 72–4  
 tension pneumothorax 96  
 tracheal intubation-related 25  
 hypoxic ventilatory drive 118–19,  
 132–3
- ibuprofen **85**  
 ICU *see* intensive care unit  
 indigestion 4  
 induction of anaesthesia  
 inhalational 27  
 intravenous 27, **30**  
 infants, basic life support 108,  
 109, **110**  
 infection control, ICU 132  
 infections  
 complicating epidural analgesia  
 88  
 hospital-acquired 116, 132  
 transfusion risks 60  
 infiltration analgesia 64–5  
 information, patient 13  
 inhalational anaesthetics  
 anaesthetic machine 42–3  
 induction of anaesthesia 27  
 inspired concentration 32, 44,  
 51  
 maintenance of anaesthesia  
 29–33
- malignant hyperpyrexia 98  
 minimizing theatre pollution  
 46–7  
 minimum alveolar  
 concentration (MAC)  
 29–32, **32**  
 scavenging systems 46–7  
 solubility 32  
*see also specific agents*  
 inotropes 97, 122, 134  
 inspiratory to expiratory (I:E)  
 ratio 129  
 insulin therapy 137  
 Intensive Care Society (ICS) 137  
 intensive care unit (ICU) 112,  
**113**, 123–37  
 common conditions treated  
 132–7  
 infection control 132  
 intubation and tracheostomy  
 129–30  
 mechanical ventilation 129  
 monitoring 124–8  
 nutrition 131–2  
 outreach teams 115  
 sedation and analgesia 130–1  
 under-provision 123–4  
*see also* critical care  
 ‘intensive care without walls’ 112,  
 115  
 intermittent positive pressure  
 ventilation (IPPV) 45  
 internal jugular vein, cannulation  
 58  
 International Association for  
 Study of Pain (IASP) 139,  
 150  
 intracranial pressure (ICP)  
 monitoring 128  
 raised, regional anaesthesia 69  
 intrathecal anaesthesia *see* spinal  
 anaesthesia/analgesia  
 intravenous anaesthesia, total  
 (TIVA) 33–4  
 intravenous cannulation 54–61  
 central *see* central venous  
 cannulation  
 complications 57  
 equipment 55  
 failure 57  
 relevant anatomy 54–5  
 technique 55–7  
 intravenous fluids 59–60  
 administration *see* fluid  
 administration  
 intravenous induction of  
 anaesthesia 27, **30**  
 intravenous regional anaesthesia  
 (IVRA) 65

## Index

- intubating laryngeal mask airway (ILM) 20, 21, 24–5, 26
- investigations, preoperative 7–9  
additional 7–9  
baseline (ASA 1) 7, **8**
- ipratropium bromide 95, 133
- ischaemic heart disease  
postoperative complications 76, 77–8  
preoperative assessment 3, 9
- isoflurane **31, 32**
- jaundice 4
- jaw thrust 17, 99, 100  
paediatric patients 108
- ketamine **30, 33**
- ketorolac 40, **85**
- lactate, serum 128, 134
- laryngeal mask airway (LMA)  
19–21, 26, 70  
insertion technique 20–1, 22  
intubating (ILM) 20, 21, 24–5, 26  
relative contraindications 20  
types available 20, 21
- laryngeal spasm 26
- laryngoscope 22
- laryngoscopy 24, 26
- latex allergy 90, 91
- left ventricular failure  
ICU management 129, 134  
postoperative 76–7  
*see also* heart failure
- left ventricular function,  
preoperative assessment  
8–9
- legs, numbness and weakness  
87
- leukaemias 9
- levo bupivacaine **62**
- lignocaine **62, 64**
- liver function tests 7, 128
- LMA *see* laryngeal mask airway
- local anaesthesia 61–7  
monitoring during 67  
peripheral venous cannulation  
56  
role 63–4  
techniques 64–5
- local anaesthetic drugs 62  
calculation of doses 63  
epidural anaesthesia 66, 87  
inadvertent overdose 63  
known allergy 69  
techniques using 64–7  
toxicity 63
- lorazepam 15
- loss of resistance technique 65–6
- lung disease, pre-existing 4
- Magill's forceps 22, 24
- magnesium sulphate 95
- maintenance of anaesthesia  
29–33
- major surgery  
postoperative fluid therapy  
79–80  
risk of major cardiac  
complication **11**
- malignant hyperpyrexia  
(hyperthermia) (MH) 5, 34,  
98–9, 111  
anaesthesia for susceptible  
patients 99  
management 98  
monitoring during anaesthesia  
51, 52
- Mallampati criteria 6, 7
- manipulation 147–8
- Mapleson breathing systems 43
- masks *see* facemasks
- MC mask 75
- mean arterial pressure (MAP)  
124–5, 134  
targets in ICU patients 134–5
- median cubital vein 54–5
- median nerve 55
- median vein of forearm 54, 55
- medical problems, coexisting  
history taking 3–4  
preoperative assessment 2  
preoperative referral 9
- medical staff, critical care training  
112–13
- Medicines and Healthcare  
products Regulatory Agency  
70, 111
- memory, pain 139
- metaraminol 68
- methadone 145
- methaemoglobin 51
- methicillin-resistant  
*Staphylococcus aureus*  
(MRSA) 132
- methylprednisolone 91
- metoclopramide 16, 78–9
- midazolam **30**
- minimum alveolar concentration  
(MAC) 29–32, **32**
- minor surgery  
postoperative fluid therapy  
79  
risk of major cardiac  
complication **11**
- Misuse of Drugs Act 1971 39
- mivacurium **36**
- Modified Early Warning Scoring  
System (MEWSS) **114**
- monitoring  
during general anaesthesia  
47–54  
additional 49, 52–3  
blood loss 53  
breathing systems 53–4  
essential 49–51  
immediately available 49,  
52  
integrated systems 50, 51  
oxygen supply 53  
potential hazards 49  
intensive care unit 124–8  
during local and regional  
anaesthesia 67  
perioperative emergencies 91  
recovery room 71
- morphine **38**  
cancer pain 150  
chronic pain 145  
patient-controlled analgesia  
(PCA) 85  
postoperative analgesia 82  
routes of administration **84**
- mortality, perioperative 10  
risk indicators 10–12
- mouth-to-mouth ventilation  
100–1, 109
- mouth-to-nose ventilation 101,  
109
- multiple organ failure syndrome  
(MOFS) 115–16  
MAP and cardiac output targets  
134–5
- muscle relaxants *see*  
neuromuscular blocking  
drugs
- muscle rigidity 98
- musculoskeletal disorders 6
- myocardial contractility  
reduced 76–7, 97  
therapy to improve 134
- myocardial infarction (MI)  
acute 77, 121–2, 123  
perioperative risk 10–12  
previous history 3
- nalbuphine 37
- naloxone 39, 82
- nasal cannulae 74–5
- nasopharyngeal airway 18, 20
- National Institute for Clinical  
Excellence (NICE) 7, **8**,  
69
- nausea  
complicating spinal anaesthesia  
68

- drugs used to treat *see*  
   anti-emetic drugs  
   postoperative 15, 78  
 neostigmine 35  
 nerve blocks 146–7  
   peripheral 85, 146  
 nerve stimulation, peripheral  
   35–7  
 neurological assessment  
   ICU patients 128  
   preoperative 6  
 neuroma 148–9  
 neuromuscular blockade  
   assessment 35–7  
   residual postoperative 73  
   reversal 35  
 neuromuscular blocking drugs  
   34–7  
   depolarizing 34  
   non-depolarizing 34–5, **36**  
 neuromuscular disorders 4  
 neuropathic pain 148  
 neurosurgical patients 123  
 New York Heart Association  
   (NYHA) functional  
   classification 3, 4  
 nitric oxide (NO), inhaled 133  
 nitrous oxide 29, 32–3  
   anaesthetic machine 42  
   diffusion hypoxia 33, 74  
   and oxygen *see* Entonox  
   in pneumothorax 96  
   supply to operating theatre  
   41  
   systemic effects 32–3  
 non-invasive positive pressure  
   ventilation (NIPPV) 119  
 non-steroidal anti-inflammatory  
   drugs (NSAIDs) 40, 83–4,  
   **85**  
   chronic pain 146  
   COX-2 specific 40, **85**  
 nosocomial infections 116,  
   132  
 nurses  
   critical care training 112–13  
   preoperative assessment 2  
 nutrition, ICU patients 131–2  
  
 obesity 17  
 oesophageal detector 25  
 oesophageal intubation,  
   inadvertent 25  
 older patients  
   epidural anaesthesia 87  
   postoperative analgesia 81  
 oliguria, postoperative 76  
 omeprazole 16  
 ondansetron **16**, 78  
  
 operating theatre  
   delivery of gases 40–2  
   minimizing pollution 46–7  
 operations  
   classification 12  
   previous history 4–5  
 opioid analgesics 37–40  
   antagonists 39  
   central and peripheral actions  
   **38**  
   chronic pain 145–6  
   complications **38**, 72, 82  
   epidural anaesthesia 66–7, 87  
   ICU patients 131  
   less potent 83  
   overdose 82  
   partial agonists and mixed  
   agonists/antagonists 37–9  
   postoperative analgesia 82–3,  
   **84**  
   premedication 16  
   pure agonists **38**  
   regular preoperative users 88  
   regulation 39  
   spinal anaesthesia 67, 88  
   supply and custody 39–40  
 opioid receptors 37  
 oral contraceptive pill (OCP) 5  
 oral fluid intake, postoperative 79  
 oropharyngeal (Guedel) airway  
   18, 19  
 osteopathy 147–8  
 outreach teams, critical care 115  
 oxycodone 82, 145  
 oxygen  
   alveolar concentration 74  
   anaesthetic machine 42  
   arterial partial pressure (PaO<sub>2</sub>)  
   118  
   delivery devices 74–5  
   inspired concentration 43–4, 46  
   anaesthetic machine controls  
   42  
   continuous monitoring 53  
   COPD 118–19  
   critical illness 118  
   delivery devices 74–5  
   postoperative hypoxaemia  
   72, 73–4  
   reduced 74  
   respiratory failure 132–3  
   masks 74–5  
   nasal cannulae 74–5  
   supply to operating theatre 41  
   toxicity 133  
 oxygen saturation  
   after tracheal intubation 25  
   mixed venous, monitoring  
   126  
  
 peripheral arterial (SpO<sub>2</sub>) 50,  
   126  
 oxygen therapy  
   COPD 118–19  
   critical illness 118  
   perioperative emergencies 92,  
   93, 95  
   postoperative hypoxaemia 74  
   respiratory failure 132–3  
 oxyhaemoglobin dissociation  
   curve, hypocapnia and  
   46  
  
 paediatric patients  
   basic life support 108–10  
   monitoring of blood loss 53  
   tracheal intubation 23  
 pain  
   acute 140  
   assessment 81–2  
   cancer 140, 146, 149–50  
   chronic *see* chronic pain  
   continuing tissue damage 140  
   definition 139  
   experience 142  
   factors affecting 81, 139–40  
   gate control theory 142  
   management programmes 148  
   measurement 144  
   mechanisms of generation  
   140–1  
   postoperative *see* postoperative  
   pain  
   useful websites 70, 89, 150  
   variability 142  
 pancuronium **36**  
 paracetamol 40, 83–4, **85**  
 parecoxib 40, **85**  
 parenteral nutrition, total (TPN)  
   131  
 patient-controlled analgesia (PCA)  
   84–5  
 peak expiratory flow (PEF) 95  
 pericardiocentesis, needle 97  
 peripheral nerve blocks 85, 146  
 peripheral nerve damage 141  
 peripheral nerve stimulation 35–7  
 peripheral perfusion, assessment  
   76, 120  
 peripheral resistance, reduced 97  
 peripheral vascular disease 3, 6  
 pethidine **38**  
 phantom limb pain 148  
 phenothiazine derivatives 79  
 phenytoin 146  
 physiotherapy 133, 148  
 piped medical gas and vacuum  
   system (PMGV) 40–2  
 platelet concentrates 60, 61



## Index

- platelet count 61  
pneumonia  
  ICU patients 132, 133  
  ventilator-associated 132  
pneumothorax 73  
tension 96  
positioning, patient  
  cardiac output and 97  
  epidural anaesthesia 66  
  postanaesthesia 72  
  recovery position 103, 104  
  spinal anaesthesia 67  
  tracheal intubation 24  
positive end expiratory pressure (PEEP) 129, 133  
positive pressure ventilation 44–5, 46, 129  
postanaesthesia care 71–89  
postdural puncture headache 68  
postherpetic neuralgia (PHN) 148  
postoperative analgesia 80–8  
  combination techniques 88  
  difficult problems 88  
  drugs used 82–3  
  techniques 84–8  
postoperative complications 72–9  
postoperative nausea and vomiting (PONV) 15, 78  
postoperative pain 80–8, 148  
  adverse consequences 73, 81  
  difficult problems 88  
  management 81–8  
potassium, postoperative replacement 80  
precordial thump 106, 107  
prednisolone 95  
pregnancy 5, 17  
premedication 15–17  
preoperative assessment 1–9  
  airway 6, 7, 8  
  clinic 2  
  examination 5–6  
  history 3–5  
  investigations 7–9  
  screening 1–2  
  urgent and emergency surgery 12  
  useful websites 13–14  
preoxygenation, tracheal intubation 23  
pressure, fluid flow rate and 59  
pressure-controlled ventilation (PCV) 133  
primary organ dysfunction 116  
prochlorperazine 79  
prone ventilation 134  
propofol **30**, 33  
Proseal laryngeal mask airway 20, 21  
prostacyclin, nebulized 133  
prostaglandins 40, 141  
prostate surgery 77  
protective ventilatory strategy 133  
prothrombin time (PT) 128  
pruritus, opioid-induced 87  
pseudocholinesterase 34  
  deficiency 34  
psychological assessment, chronic pain 144  
psychological therapy, chronic pain 148  
pulmonary arterial vasodilator therapy 133  
pulmonary artery flotation catheter (PAFC) 126  
pulmonary artery pressures 126  
pulmonary diffusion defects 74  
pulmonary function tests 8  
pulmonary oedema 74  
pulse 101–2, 120  
pulse contour analysis 125  
pulseless electrical activity (PEA) 104, 107  
pulse oximetry 50–1, 126  
Ramsay sedation scale 128, **131**  
ranitidine 16, 91  
rebreathing, indication 51  
record, anaesthetic 54  
recovery area 71  
  discharge from 71, **72**  
  recovery position 103, 104  
red cell concentrate 60, 61  
red cells in optimal additive solution 60  
reflex activity, tracheal intubation-induced 25–6  
reflex sympathetic dystrophy 149  
reflux, gastro-oesophageal 4, 17  
regional anaesthesia 61–9  
  awake vs after induction 68–9  
  ICU patients 131  
  monitoring during 67  
  postoperative analgesia 85–8  
  role 63–4  
  techniques 64–7  
relatives  
  malignant hyperpyrexia 98  
  unconscious patient and consent 12  
remifentanil **38**  
renal disease 9  
renal failure  
  acute 127, 135–6  
  chronic 4, 9  
  morphine therapy 82  
  pre-renal vs intrinsic 127, **128**  
renal function  
  ICU patients 127  
  preoperative testing **8**  
renal replacement therapy 9  
renin–angiotensin system 80  
rescue breathing 100–1  
reservoir bag 43  
respiratory depression 72, 82, 87  
respiratory disease  
  local or regional anaesthesia 64  
  medical referral 9  
  preoperative assessment 4, 6  
respiratory distress 95, 96  
respiratory failure 6, 118, 132–4  
  causes 118, **119**  
  mechanical ventilation 129  
  prone ventilation 134  
  pulmonary arterial vasodilator therapy 133  
respiratory rate 118  
respiratory tract infections 4  
resuscitation  
  ABC principles *see* ABC of resuscitation  
  cardiopulmonary *see* cardiopulmonary resuscitation  
  critically ill patients 117–22  
  do not attempt (DNAR) orders 116–17  
  opioid-induced respiratory depression 82  
  severe hypotension 97  
  *see also* advanced life support; basic life support  
Resuscitation Council (UK) 111  
  arrhythmia guidelines 77, 89  
  cardiopulmonary resuscitation guidelines 99  
  Universal Algorithm 105  
rheumatoid arthritis  
  pain 140, 145  
  preoperative assessment 4, 6, 8  
risk (anaesthesia and surgery)  
  9–12  
  indicators 10–12  
  major 9–10  
  minor 9  
  by type of surgery 11–12  
rocuronium **36**  
rofecoxib **85**  
ropivacaine **62**  
rotameters 42  
Royal College of Anaesthetists 70  
SAG-M solution 60  
salbutamol 91, 95, 133  
saline (sodium chloride) solutions **59**, 61



- scavenging systems 46–7
- scheduled surgery 12
- scoring systems, critical care 113–15, 124
- screening, preoperative 1–2
- secondary organ dysfunction 116
- sedation
  - complicating epidural analgesia 87
  - harmful effects of deep **131**
  - ICU patients 128, 130–1
  - preoperative 15
- Seldinger technique 55, 58
- Sellick's manoeuvre 26
- sepsis 97, 121
- sepsis syndrome 134, 136–7
- septic shock 77, 120
- sevoflurane 27, **31, 32**
- shock, circulatory 121–2
- sickle-cell screen (Sickledex) 8
- sinus bradycardia 78, **122**
- sinus tachycardia 77, **122**
- smoking 5
- social history 5
- sodium chloride solutions **59**, 61
- sodium citrate 16, 92
- Specific Activity Scale 3, 4
- spinal anaesthesia/analgesia 64, 67
  - chronic pain 146–7
  - complications 67–8, 77
  - contraindications 69
  - postoperative 88
- spinal cord injury 97
- spinal cord stimulation 147
- spinal surgery, previous 69
- stages of anaesthesia 29
- starch solution **59**
- starvation, preoperative 17
- steroids
  - acute severe asthma 95
  - allergic reactions 91
  - anti-emetic use 79
  - chronic pain 146
  - preoperative 17
- stethoscope 22
- stress response 80
- stridor 94
- subclavian vein, cannulation 58
- suctioning, airway 22, 133
- sugar, blood *see* glucose, blood
- supraventricular tachycardia 77–8, **122**
- surgery
  - classification 12
  - previous history 4–5
  - risk 9–12
  - stress response 80
- suxamethonium 34
  - adverse effects 34, 98
  - apnoea 34
- sympathetic activity, intubation-associated 16
- sympathetic blockade 147
- systemic inflammatory response syndrome (SIRS) 116, 136–7
- tachycardia **122**
  - extreme 97
  - perioperative emergencies 94, 95
  - postoperative 76, 77–8
- tachypnoea 95, 98, 118
- target controlled infusion (TCI) 33
- temazepam 15
- temperature, monitoring during anaesthesia 52
- thiopentone **30**
- third space fluid losses 61, 80
- thoracic surgery 81
- thrombophlebitis 57
- thyromental distance 6, 8
- tidal volume 46, 133
- tissue injury 140, 141
- topical anaesthesia 64
- total intravenous anaesthesia (TIVA) 33–4
- total parenteral nutrition (TPN) 131
- tracheal intubation 21–7
  - in airway obstruction 95
  - complications 25–6
  - cricoid pressure 26
  - difficult 26
    - preoperative prediction 6, 7, 8
  - equipment 22
  - failed 25, 26–7, 93–4
  - ICU patients 129–30
  - indications 21
  - nasal 24
  - technique of oral 23–4
- tracheal tubes 23
  - confirming position 25
  - cuffed 23
  - sizes 22
  - types 23
- tracheostomy 129–30
- training, critical care 112–13
- train-of-four (TOF) stimulation 35
- tramadol 37–9, 83, 145–6
- transcutaneous electrical nerve stimulation (TENS) 147
- transoesophageal echocardiography (TOE) 127
- trauma
  - chest compression causing 102
  - intraoperative fluid loss 61
  - stress response 80
  - during tracheal intubation 25
- tricyclic antidepressants 146
- trigeminal neuralgia 143, 149
- tryptase, plasma 91
- Tuohy needle 65, 66, 68
- unconscious patient
  - acute airway obstruction 94, 95, 117–18
  - basic life support 99–100
  - consent issues 12
- upper limb, anatomy of veins 54–5
- urea and electrolytes 7, **8**
- urgent surgery 12
- urine output
  - ICU monitoring 127
  - monitoring during anaesthesia 52
  - reduced postoperative 76, 80
- urine retention 87
- vacuum, medical 41–2
- vacuum-insulated evaporator (VIE) 41
- valvular heart disease 6, 9
- vaporizers 29, 42–3
- vapour concentration analyser 51
- vasodilatation 77, 97
- vasodilator therapy 134
  - pulmonary arterial 133
- vasopressors 68, 97
- vecuronium **36**
- veins, upper limb 54–5
- venepuncture *see* intravenous cannulation
- venous return, decreased 97
- ventilation
  - alveolar *see* alveolar ventilation
  - expired-air 100–1, 109
  - failed 25, 26–7, 93–4
  - impaired 6, 73
  - mechanical 44–6
    - COPD 119–20
    - ICU patients 129
    - respiratory failure 133
    - ventilation/perfusion mismatch 73
    - weaning 129–30
  - monitoring adequacy 51, 53
  - mouth-to-nose 101
  - positive pressure 44–5, 46, 129

## Index

- ventilation (*cont.*)
  - prone 134
  - protective strategy 133
  - recovery room equipment 71
  - see-saw 72, 94, 117
- ventilation/perfusion (*V/Q*)
  - mismatch 46, 73–4, 129
- ventilators
  - anaesthetic 44–6
  - bag-in-bottle 46, 48
  - gravity-powered 46, 47
  - ICU 129, **130**
  - modern electronic 46, 49
- ventricular fibrillation (VF) 104,  
105–7
  - see also* defibrillation
- ventricular tachycardia (VT) 104,  
**122**
  - management 105–6, 107
- Venturi mask 75
- viscosity, fluid 58
- vomiting
  - complicating spinal anaesthesia 68
  - drugs used to treat *see*
    - anti-emetic drugs
      - induced by tracheal intubation 25–6
      - postoperative 15, 78
- weaning, ventilatory support 129–30
- Wilson score 6
- X-rays
  - chest 7, **8**, 58, 96
  - cervical spine 8
- yoga 148







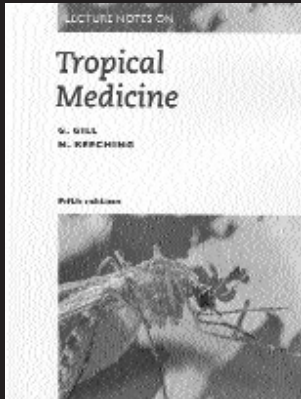

# Lecture Notes on Tropical Medicine

## Fifth Edition

Geoff Gill and Nick Beeching  
February 2004. 368 pages 86 illustrations  
ISBN 063206496X Paperback £16.95

\*Emphasis on the clinical aspects of problem solving and management in the tropics

\*Emphasises a problem-based clinical approach using clinical presentations

\*An increased global approach to medicine in the tropics not just tropical and exotic diseases

\*New chapter on non-communicable diseases, such as epilepsy, diabetes and heart disease, which are becoming more widespread in the tropics

\*New chapter on refugee health that covers humanitarian disasters, control of epidemics and health assessment of asylum seekers

\*Over 25 expert contributors

Lecture Notes on Tropical Medicine is a core text with an emphasis on the practical aspects of problem-solving in the tropics. It is a very practical companion for the increasing number of medical students and junior doctors who have the opportunity to practice medicine in the tropics.

This new, revised edition includes a more global and syndromic approach to tropical medicine. In addition to covering the serious and relevant tropical diseases, the book also covers conditions and diseases that are becoming more widespread in the tropics such as epilepsy, diabetes and AIDS.

Carefully selected colour plates and an increased number of illustrations, effectively portray clinical conditions. This edition includes a separate section on HIV and reflects the impact that AIDS has had on the tropics.

### ORDER FORM

To place an order for this book, simply complete and return this order form to:  
**Marston Book Services, PO Box 269, Marston, Oxon OX14 4YN, UK**  
Tel: +44 (0)1235 465500 Fax: +44 (0)1235 465556 E-mail: [direct.orders@marston.co.uk](mailto:direct.orders@marston.co.uk)  
Web: [www.blackwellmedicine.com](http://www.blackwellmedicine.com)

Please send me \_\_\_\_\_ copies of **Lecture Notes on Tropical Medicine** (ISBN 063206496X) at **£16.95** each

I enclose a **cheque** for £ \_\_\_\_\_ made payable to **Marston Book Services Ltd.**

**UK £3.00** (+£1.00 per additional item) **Europe £4.00** (+£1.50 per additional item) **Rest of World £5.50** (+£2.00 per additional item)

Please charge my **credit card** £ \_\_\_\_\_ **Access / Amex / Visa / Mastercard / Switch**

Card number

Expiry date: \_\_\_\_\_ / \_\_\_\_\_ Issue number (Switch only): \_\_\_\_\_

Signature: \_\_\_\_\_ Date: \_\_\_\_\_

Name: \_\_\_\_\_

Address: \_\_\_\_\_

Postcode: \_\_\_\_\_ Country: \_\_\_\_\_ T telephone: \_\_\_\_\_

If you would like to receive similar information from us on related books and journals please tick here



**Blackwell  
Publishing**

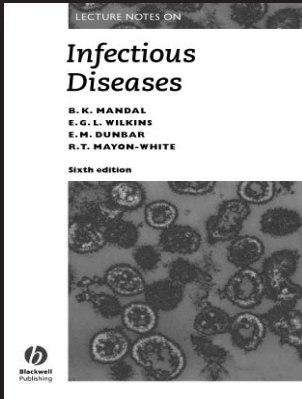

Integrates the basic science with clinical practice

Core introductory text for the student and the practitioner

Major update throughout and new chapter on infections in special groups e.g. travellers and drug users

Includes information on the new control measures and emerging infections, especially those with bioterrorism potential

Information is provided on global occurrence where relevant

Update information on SARS

# Lecture Notes on Infectious Diseases

## Sixth Edition

**BK Mandal, EGL Wilkins, EM Dunbar and Richard Mayon-White**  
December 2003. 280 pages 16 illustrations  
ISBN 1405108207 Paperback £16.95

This core text provides an excellent concise introduction to infectious diseases. The book integrates basic science with clinical practice, with disease-orientated descriptions and clinical presentations on a system-by-system basis. It is therefore ideal for both the student and the practitioner.

For this new sixth edition the text has been brought fully up to date throughout. The highly structured and improved text is designed to facilitate easy access to information, making the book an ideal resource for clinical attachments and revision. There is a new chapter that covers infections in special groups, as well as coverage of sepsis and septic shock. The Introductory chapter also takes into account new control measures, emerging infections, and infections linked with bioterrorism. Information on global occurrence is added to the epidemiology sections where relevant and web site information has been included to provide up-to-date resources on fast moving topics such as AIDS, and travel-related infections such as SARS.

The result is a text that is a compact yet comprehensive guide to infectious diseases. It will appeal to medical students, junior doctors, general practitioners, and allied health professionals who want a concise introduction to the subject or an ideal revision companion.

### ORDER FORM

To place an order for this book, simply complete and return this order form to:

**Marston Book Services, PO Box 269, Marston, Oxon OX14 4YN, UK**  
Tel: +44 (0)1235 465500 Fax: +44 (0)1235 465556 E-mail: [direct.orders@marston.co.uk](mailto:direct.orders@marston.co.uk)  
Web: [www.blackwellmedicine.com](http://www.blackwellmedicine.com)

Please send me \_\_\_\_\_ copies of **Lecture Notes on Infectious Diseases**  
(ISBN 1405108207) **£16.95** each

I enclose a cheque for £\_\_\_\_\_ made payable to **Marston Book Services Ltd.**

**UK £3.00** (+£1.00 per additional item) **Europe £4.00** (+£1.50 per additional item) **Rest of World £5.50** (+£2.00 per additional item)

Please charge my credit card £\_\_\_\_\_ Access / Amex / Visa / Mastercard / Switch

Card number

Expiry date: \_\_\_\_\_ / \_\_\_\_\_ Issue number (Switch only): \_\_\_\_\_

Signature: \_\_\_\_\_ Date: \_\_\_\_\_

Name: \_\_\_\_\_

Address: \_\_\_\_\_

Postcode: \_\_\_\_\_ Country: \_\_\_\_\_ T telephone: \_\_\_\_\_

If you would like to receive similar information from us on related books and journals please tick here



**Blackwell  
Publishing**

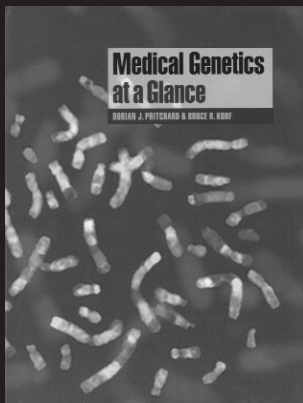

# Medical Genetics at a Glance

**First Edition**

**Dorian Pritchard and Bruce R Korf**  
**December 2002. 120 pages 48 illustrations**  
**ISBN 0632063726 Paperback £15.95**

Medical Genetics at a Glance is a concise, well-illustrated and accessible genetics textbook. It follows the now familiar, easy-to-use, double page spread format of the at a Glance series. Each double page presents clear, memorable diagrams that illustrate essential information with accompanying text that covers key topics and issues in more detail.

Structured into three distinct sections, Medical Genetics at a Glance, takes the student through developmental biology, medical genetics and the clinical application of genetics. The first section focuses on basic biological concepts such as cell and chromosome structure, molecular biology and the cell cycle, as well as human embryonic development and sexual maturation. The second section applies these principles to medicine through the essential 'laws' of inheritance, the chromosome anomalies, multifactorial inheritance, normal polymorphism and gene frequency, then moving on to gene mapping, mutagenesis, cancer and immunogenetics. The final section addresses the clinical application of the above principles in pedigree drawing and molecular diagnostic procedures based on the human gene map, PCR and Southern techniques, risk assessment, genetic counselling, gene therapy and much more.

Medical Genetics At A Glance is an ideal resource that fits the budget and reading time of medical students and those seeking a quick yet thorough, introduction to this fast moving field. It can be used as primary or supplementary reading in a lecture-based course and is perfect for exam preparation.

\* Concise introduction and revision text

\* Covers the core principles of cell biology & genetics

\* Three section structure covering developmental biology, medical genetics and clinical application of genetics

\* Considers the essential practical and philosophical aspects of medical genetics

\* Presents clinical material in context

\* Contains useful glossary of terms

## ORDER FORM

To place an order for this book, simply complete and return this order form to:

**Marston Book Services, PO Box 269, Marston, Oxon OX14 4YN, UK**

**Tel:** +44 (0)1235 465500 **Fax:** +44 (0)1235 465556 **E-mail:** [direct.orders@marston.co.uk](mailto:direct.orders@marston.co.uk)

**Web:** [www.blackwellmedicine.com](http://www.blackwellmedicine.com)

Please send me \_\_\_\_\_ copies of **Medical Genetics at a Glance**  
(ISBN 0632063726) at **£15.95** each

I enclose a **cheque** for £ \_\_\_\_\_ made payable to **Marston Book Services Ltd.**

**UK £3.00** (+£1.00 per additional item) **Europe £4.00** (+£1.50per additional item) **Rest of World £5.50** (+£2.00per additional item)

Please charge my **credit card** £ \_\_\_\_\_ **Access / Amex / Visa / Mastercard / Switch**

**Card number**

**Expiry date:** \_\_\_\_\_ / \_\_\_\_\_

**Issue number (Switch only):** \_\_\_\_\_

**Signature:** \_\_\_\_\_ **Date:** \_\_\_\_\_

**Name:** \_\_\_\_\_

**Address:** \_\_\_\_\_

**Postcode:** \_\_\_\_\_ **Country:** \_\_\_\_\_ **T** **telephone:** \_\_\_\_\_

If you would like to receive similar information from us on related books and journals please tick here



**Blackwell  
Publishing**