

G NEIL MARTIN

HUMAN NEUROPSYCHOLOGY

SECOND EDITION



PEARSON
Prentice
Hall

Additional
student support at
www.pearsoned.co.uk/martin

Human Neuropsychology

Second edition

G. Neil Martin
Middlesex University



Harlow, England • London • New York • Boston • San Francisco • Toronto • Sydney • Singapore • Hong Kong
Tokyo • Seoul • Taipei • New Delhi • Cape Town • Madrid • Mexico City • Amsterdam • Munich • Paris • Milan

Pearson Education Limited

Edinburgh Gate
Harlow
Essex CM20 2JE
England

and Associated Companies throughout the world

Visit us on the World Wide Web at:
www.pearsoned.co.uk

First published 1998 by Prentice Hall Europe
Second edition published 2006

© Prentice Hall Europe 1998
© Pearson Education Limited 2006

The right of G. Neil Martin to be identified as author of this work has been asserted by him in accordance with the Copyright, Designs and Patents Act 1988.

All rights reserved. No part of this publication may be reproduced, stored in a retrieval system, or transmitted in any form or by any means, electronic, mechanical, photocopying, recording or otherwise, without either the prior written permission of the publisher or a licence permitting restricted copying in the United Kingdom issued by the Copyright Licensing Agency Ltd, 90 Tottenham Court Road, London W1T 4LP.

ISBN-13: 978-0-131-97452-4
ISBN-10: 0-131-97452-1

British Library Cataloguing-in-Publication Data

A catalogue record for this book is available from the British Library

Library of Congress Cataloging-in-Publication Data

Martin, G. Neil.

Human neuropsychology / G. Neil Martin.-- 2nd ed.
p. ; cm.

Includes bibliographical references and index.

ISBN-13: 978-0-13-197452-4

ISBN-10: 0-13-197452-1 (pbk.)

1. Neuropsychology. I. Title.

[DNLM: 1. Neuropsychology. 2. Brain Diseases--physiopathology. WL 103.5 M381h 2006]

QP360.M3515 2006

612.8--dc22

2005053754

10 9 8 7 6 5 4 3 2 1
11 10 09 08 07 06

Typeset in 10/12pt Times New Roman
Printed by Ashford Colour Press Ltd., Gosport

The publisher's policy is to use paper manufactured from sustainable forests.

Brief contents

1	Neuropsychology: its aims, history and methods	1
2	The brain I: basic neurophysiology	55
3	The brain II: basic neuroanatomy	75
4	Hemispheric localization and lateralization of function	123
5	The frontal lobes: cognition, social behaviour and personality	163
6	Disorders of perception	211
7	Movement disorders	253
8	The neuropsychology of language and language disorders	273
9	Memory	321
10	Emotion – normal aspects	345
11	The dementias	365
12	Disorders of thought and mood	393
13	Development and recovery of function	423
14	Neuropsychological assessment	453

Contents

Figures	xv
Plates	xx
Tables	xxi
Boxes	xxii
Preface to the second edition	xxv
Preface to the first edition	xxvii
Acknowledgements	xxix
Guided tour	xxxii

1 Neuropsychology: its aims, history and methods 1

Neuropsychology: some history and definitions	1
The head and the heart	2
Human neuropsychology: development of the discipline	3
The fourth to the fourteenth century: the importance of the ventricles	5
Discoveries in the brain	6
Neuropsychology's bumpy ride: phrenology	7
Discoveries of the nineteenth century: Broca and speech production	8
Discoveries of the nineteenth century: Wernicke and speech comprehension	9
One dog, two scientists and a German dressing table: the beginning of modern neuropsychology	9
Mapping brain function: Brodmann and others	10
From the nineteenth to the twenty-first century	10
The tools of human neuropsychology: measuring brain function and structure	12
The single-case study: in-depth exploration of brain injury and disrupted function	12
Connectionism/neural networks/computational modelling	20
Electroencephalography (EEG)	21
Event-related potentials (ERPs)	24
Magnetoencephalography (MEG)	29
Computerized tomography (CT)	30
Positron Emission Tomography (PET)	32
Single Photon Emission Computerized Tomography (SPECT)	33
Magnetic Resonance Imaging (MRI)	35
Functional Magnetic Resonance Imaging (fMRI)	37
Biochemical techniques	39
Brain electrical stimulation	41
Modern brain stimulation: trans-cranial magnetic stimulation	42
Lateralization techniques	45
Summary	51
Recommended further reading	52

2 The brain I: basic neurophysiology 55

The nervous system and its two major divisions	55
Cells in the nervous system	56
The neuron	57
The axon and myelination	60
Different types of neuron	61
Glial cells	63
Astrocytes (astroglia)	63
Oligodendrocytes (oligodendroglia)	64
Microglial cells	64
Schwann cells	64
How neurons communicate I: the action potential	65
The membrane potential	65
Depolarization and hyperpolarization	66
How is the nerve impulse transmitted?	67
How neurons communicate II: neurotransmission	68
The synapse	68
What is a neurotransmitter?	70
Types of neurotransmitter	70
Acetylcholine	70
Monoamines (biogenic amines)	71
Glutamate	71
γ -aminobutyric acid	71
Glycine	71
How is neurotransmission stopped?	72
Neurogeographical location of neurotransmitters	72
The simplest of systems?	72
Summary	73
Recommended further reading	73

3 The brain II: basic neuroanatomy 75

Introduction: coming to terms with terms	76
Positional terms	76
Development of the central nervous system	80
Spinal cord	81
Spinal nerves	82
Brainstem	83
Medulla oblongata	83
Pons	84
Mesencephalon	84
Diencephalon	84
Cerebellum	85
Cerebral cortex	85
Fissures and sulci	86
Lobes of the brain	86
Basal ganglia	90
Limbic system	91

Organization of the cerebral cortex	92
The six layers of the cortex	92
Columns of the cortex	93
Connections between brain regions	93
Cranial nerves	94
Covering the brain	95
Ventricular system	96
Arteries of the brain	97
Malfunctions of the brain	99
Closed-head injury	99
Cerebral oedema	99
Infarction	99
Ischaemia	99
Thrombosis	99
Cerebrovascular accident/stroke	99
Haemorrhage (subarachnoid)	100
Tumour (intracranial)	100
Anoxia	101
Encephalopathy	101
Encephalitis	101
Hydrocephalus	101
Headache	101
Sensory and motor systems	102
Visual system	102
Auditory system	111
Somatosensory system	114
Gustatory system	114
Olfactory system	117
Motor system	118
Summary	120
Recommended further reading	121

4 Hemispheric localization and lateralization of function 123

Introduction	124
Laterality in non-humans	125
Laterality in humans	126
Physical asymmetry	126
Neuroanatomical asymmetry	127
Functional hemispheric asymmetry: some preliminary observations	128
Language	129
Visuospatial ability	131
Imagery	133
Attention	134
Perception of music	136
Mathematical ability	137
Individual differences	138
Sex and spatial ability	138
Sex and language	140

Handedness	141
Handedness, language and neuroimaging	143
The right-shift theory	143
Interhemispheric communication: callosal syndromes	145
What is a callosal syndrome?	145
Commissurotomy: a brief history	145
Corpus callosum	146
Characteristics of split-brain patients	148
Somatosensory effects	148
Visual effects	149
Other symptoms	150
Compensatory actions	150
Interhemispheric transfer: callosal channels?	150
Models of interhemispheric transfer	151
Levy and Trevarthen's metacontrol	151
Banich's model of interhemispheric processing	152
Cook's model of corpus callosum function	152
Why does hemispheric lateralization exist?	154
Motor theory of language development	155
Crowding	155
Global versus local processing	156
Geschwind and Galaburda's model	156
Stimulus – or processing – dependence?	157
Summary	160
Recommended further reading	161

5 The frontal lobes: cognition, social behaviour and personality 163

Frontal lobes: a brief review	163
Frontal lobes: an anatomical sketch	165
Early studies of frontal lobe function	166
Tests used to measure frontal lobe (dys)function	167
The symptoms: an introduction	171
Motor (precentral) symptoms	172
Sensory/perceptual symptoms	172
Cognitive (prefrontal) symptoms	175
Do the frontal lobes mediate intelligence?	187
Decision making	188
A note about the vagus nerve	189
Reasoning	190
Understanding what others do: theory of mind and the frontal lobe	191
Recent evidence for frontal cortex involvement	192
Social behaviour and personality	194
Theories of frontal lobe function	201
Luria's theory: the classical view	201
Norman and Shallice's supervisory attentional system	202
Rolls's theory of orbito-frontal function: stimulus–reward	203

Damasio's somatic marker hypothesis	203
Summary	207
Recommended further reading	208

6 Disorders of perception 211

Introduction	211
Blindsight	212
Agnosia	214
Visual agnosia	215
Apperceptive visual agnosia	216
Farah's classification of apperceptive visual agnosia	218
Associative visual agnosia	218
Optic aphasia	219
Colour agnosia	220
Theories of visual agnosia	220
Apperceptive agnosia	221
Associative agnosia	221
Category-specific visual agnosia	222
Prosopagnosia	225
Locus of damage	227
Covert recognition in prosopagnosia	230
Amygdala and face processing	230
Models of face processing	231
Landmark agnosia	233
Auditory agnosia	234
Pure word deafness	234
Auditory sound agnosia	234
Receptive amusia	234
Somatosensory agnosia	235
Unilateral spatial neglect	235
Tests of spatial neglect	236
Factors influencing spatial neglect	239
Reducing spatial neglect	244
Location of lesions in spatial neglect	244
Explanations for spatial neglect	245
Summary	249
Recommended further reading	249

7 Movement disorders 253

Some disorders of the human motor system	253
Parkinsonism and Parkinson's disease	254
Clinical features	254
Neuropathology	255
Neurotransmission	255
Treatment	256
Aetiology	258

Huntington's disease	259
Clinical features	259
Neuropathology	260
Treatment	260
Aetiology	260
Sydenham's chorea	260
Dyskinesia	261
Gilles de la Tourette syndrome	261
Wilson's disease	262
Motor neuron damage	262
Myoclonus	262
Ataxia	263
Apraxia	263
Tests of apraxia	264
Types of apraxia	264
Cerebral basis of apraxia	266
Theories of apraxia	267
Hemiplegia	268
Summary	271
Recommended further reading	271

8 The neuropsychology of language and language disorders 273

The neuropsychology of language: an introduction	274
The neuropsychology of speech production and comprehension: brain activation in healthy individuals	275
Universal language areas	276
The neuropsychology of speech production and comprehension: language disorders	279
Aphasia	279
Sensory (Wernicke's) aphasia	282
Production (Broca's) aphasia	283
Conduction aphasia	284
Deep dysphasia	285
Transcortical sensory aphasia	285
Transcortical motor aphasia	285
Global aphasia	286
Recovery from aphasia	286
Challenges to the traditional model of aphasia	291
Specific language functions	292
Spoken word recognition	292
Spoken word production	292
Grammatical representation of words	293
Production of sentences	294
The neuropsychology of normal reading	295
Translating from print to sound	296
Deriving meaning	296
Pathways to reading	297
Discourse	300

The neuropsychology of reading: dyslexia	301
Acquired dyslexia	301
Developmental dyslexia	305
Neuroimaging and dyslexia	307
Dyslexia and functional disconnection	309
Anterior language regions, disconnection and compensation	309
Developmental dyslexia and neurophysiology	310
Electrophysiological evidence of anterior and posterior abnormalities	311
A model of reading, and some neuropsychological evidence	314
Dysgraphia/agraphia	316
Phonological dysgraphia	316
Orthographic (surface) dysgraphia	317
Deep dysgraphia	317
Summary	317
Recommended further reading	318

9 Memory 321

Memory defined	321
Before memory: learning	323
Where are long-term memories formed?	324
Chemical modulation of LTP	325
Amnesia	326
Diencephalon	326
Encoding and retrieval in episodic and semantic memory	333
Working memory	337
The neurochemical basis of working memory	340
Spatial navigation and memory	340
Are memory processes lateralized?	342
Summary	343
Recommended further reading	343

10 Emotion – normal aspects 345

What is an emotion?	345
Subcortical structures and emotion	347
Hippocampal system	347
The amygdala and the conditioning of fear	348
The amygdala and fear in humans	350
Frontal lobes: happiness, sadness and inappropriate behaviour	354
Hemispheric asymmetry and the recognition and expression of emotion	355
Emotional perception	355
Emotional experience	356
Emotional experience: anger and disgust	358
Hemispheric lateralization and emotion: neuroimaging data	359
Models of human emotional expression: neuropsychology perspectives	359
Summary	363
Recommended further reading	363

11 The dementias 365

Dementia	365
Dementia of the Alzheimer type	367
Clinical features	367
Neuropathological features	371
Neurochemical features	372
Aetiology of Alzheimer's disease	373
Genetic factors	373
Transmissible agents	374
Nasal infection	375
Treatment of Alzheimer's disease	375
Vascular dementia	376
Pick Complex	377
Fronto-temporal lobe dementia	378
Lewy body dementia	378
Parkinson's disease and Huntington's disease	379
Subcortical dementia	379
Alcoholic dementia	380
Korsakoff's psychosis	380
Clinical features	380
Neuropathological features	381
Dementia associated with infection	381
Viral dementia	381
Post-infectious encephalomyelitis	382
Human immunodeficiency virus type I encephalopathy	382
Creutzfeldt–Jakob disease	382
The neuropsychology of ageing	382
The process of ageing	383
Memory	383
Processing speed and the frontal lobes	385
Summary	390
Recommended further reading	390

12 Disorders of thought and mood 393

Introduction	393
Schizophrenia	394
Subtypes of schizophrenia	395
Cognitive deficits	396
Genetics and schizophrenia	396
Abnormalities in brain structure	396
Abnormalities in brain activation	397
Neurotransmitter abnormalities	398
Epilepsy	398
Generalized epilepsy	399
Partial (focal) epilepsies	399
Cognitive impairment in epilepsy	400
Disorders of mood	400

Depression: a description	401
Anxiety: a description	407
Summary	419
Recommended further reading	420

13 Development and recovery of function 423

Development and recovery of function: an introduction	423
Neural characteristics of development	424
Structural development: MRI evidence	428
Effect of environment on brain development	429
Development of functional asymmetry	430
Neuroimaging and development of function	431
Recovery of function	432
Recovery from aphasia	432
Variables affecting recovery from aphasia	432
Sparing of function: some mechanisms	436
Some problems with recovery	438
Measures of recovery	439
Explanations for recovery	439
Neuropsychological rehabilitation	442
Rehabilitation of language function	443
Rehabilitation of memory	444
Using compensatory strategies in amnesia	445
Summary	449
Recommended further reading	450

14 Neuropsychological assessment 453

What is neuropsychological assessment?	453
Before neuropsychology: the neurological examination	454
Principles of neuropsychological assessment	456
Fixed battery versus flexible testing	456
The neuropsychological battery	458
Wechsler Adult Intelligence Scales (WAIS; WAIS-R; WAIS-III)	458
Other 'non-neuropsychological' test batteries	460
Halstead–Reitan Battery	460
Luria–Nebraska Neuropsychological Battery	461
Other 'neuropsychological' test batteries	461
Individual tests	462
Brief cognitive tests	462
Estimates of premorbid intelligence	462
Reasoning and concept formation	465
Memory – the WMS	465
Other tests of memory	466
Attention and vigilance	469
Language function	469
Visuospatial ability	470

Apraxia	473
Practical issues in neuropsychological assessment	473
Education	475
Choice of test	475
Neuropsychological assessment in children	476
Assessor–patient interaction	478
Patient compliance	479
Malingering	479
Faults in conducting and reporting the results of neuropsychological assessment	479
Computer-based assessment	480
Summary	483
Recommended further reading	484

Appendix Resources for neuropsychology students 485

Sources of information	485
Journals	485
Neuropsychology websites and software	489
Societies	491

References 493

Index 553

Supporting resources

Visit www.pearsoned.co.uk/martin to find valuable online resources

Companion Website for students

- Multiple choice questions to help you test your learning
- Essay questions to consolidate your understanding

For instructors

- PowerPoint slides that can be downloaded and used as OHTs

Also: The Companion Website provides the following features:

- Search tool to help locate specific items of content
- E-mail results and profile tools to send results of quizzes to instructors
- Online help and support to assist with website usage and troubleshooting

For more information please contact your local Pearson Education sales representative or visit www.pearsoned.co.uk/martin

Figures

1.1	An extract from the Edwin Smith Surgical Papyrus	4
1.2	One system of ventricular organization (by Albertus Magnus in <i>Philosophia naturalis</i>)	5
1.3	The withdrawal reflex as conceived by Descartes	6
1.4	A photograph of Tan's brain, with the egg-shaped cavity exposed	8
1.5	Brodmann's cytoarchitectonic maps (a) shows a lateral view; (b) shows a cross-section through the brain	11
1.6	A reproduction of the figure rendered by Weiskrantz to plot the pathway of the foil through NA's brain	15
1.7	A selection of electrode sites from the 10–20 International Electrode Placement System	22
1.8	A typical experimental setting for recording of EEG	22
1.9	The conversion of the raw EEG from three electrodes (F3, C3 and P3) into the four classical EEG frequencies, from slowest to fastest (delta, theta, alpha, beta)	23
1.10	Differences in the amplitude and latency of the N400 when people listened to sentences where the last word made the statement into a joke	26
1.11	Example of the N100 (the negative peak) and P200 (the positive peak) elicited by an auditory stimulus. The two waves represent EPs recorded while participants listened to a tone during exposure to two different odours	26
1.12	Two examples of EPs elicited by auditory stimuli. The waves on the left represent potentials evoked by a series of same-tone stimuli (e.g. a low tone); the waves on the right represent potentials evoked by a series of two different tones (e.g. a high and a low tone). In the latter condition, the P300 is evoked by the 'different-sounding' tone	27
1.13	A comparison between the ERPs from patients with Alzheimer's disease and those from control subjects. A markedly reduced P300 is seen for the demented patients at each electrode site	28
1.14	The number of neuropsychological studies using PET and fMRI published from 1988 to 1998	32
1.15	(a) Sagittal view of an MRI scan of a living human brain; (b) MRI scans taken from a patient with damage to Wernicke's area following cerebrovascular accident	35
1.16	A motor homunculus	41
1.17	A typical rTMS procedure	42
1.18	The pathway of auditory signals during dichotic listening	45
1.19	A typical testing session involving the tachistoscopic presentation of stimuli. As the subject fixates on a central spot, an image can be flashed to that spot or to its left or right	46
1.20	The crossover seen in the visual pathway	47
1.21	The naming times for the solution and for unrelated target words in the solved and unsolved problem conditions	48
1.22	The author's MRI scan	51
2.1	The neuron and its processes	58
2.2	Examples of axonal synapses	60

2.3	(a) An oligodendrocyte; (b) a Schwann cell	61
2.4	Types of neuron and interneuron	62
2.5	Types of cell: (a) unipolar cell; (b) bipolar cell; (c) pseudo-unipolar cell; (d), (e) and (f) three types of multipolar cell	62
2.6	An astrocyte	64
2.7	The flow of potassium across a cell membrane	67
2.8	The effects of excitation and inhibition on a neuron: (a) excitation; (b) inhibition; (c) excitation and inhibition	68
2.9	Example of communication between cells and other parts of the body	69
3.1	Positional terms illustrated diagrammatically	77
3.2	Coronal section of a human brain	78
3.3	Coronal section seen via an MRI scan	79
3.4	Horizontal section of a human brain	79
3.5	Horizontal section seen via an MRI scan	80
3.6	Principal divisions of the central nervous system	81
3.7	The spinal cord and vertebrae	82
3.8	(a) Dorsal view of a human brain; (b) schematic of a human brain	87
3.9	(a) Lateral view of a human brain; (b) schematic of a human brain	88
3.10	The area of the parietal lobe activated in Fogassi <i>et al.</i> 's (2005) experiment	89
3.11	The basal ganglia. The arrows show the pathways of the dopaminergic neurotransmitter system	90
3.12	The limbic system: (a) general location of structures; (b) structures in detail	91
3.13	Cortical areas and association areas of the brain	94
3.14	The cranial nerves	95
3.15	The ventricles of the brain	96
3.16	Arteries of the brain	97
3.17	(a) Lateral distribution of the middle cerebral artery; (b) medial distribution of the anterior and posterior cerebral arteries	98
3.18	Monocular and binocular zones of the visual fields	103
3.19	Pathway from the visual field to the brain	104
3.20	Parvocellular and magnocellular visual fields	105
3.21	The two visual routes (dorsal and ventral) in the primary visual cortex	108
3.22	(a) The number of correct responses and (b) the reaction times made by Humphreys and Riddoch's (2001) patient MP; (c) the area lesioned in MP and the other patients in the same study	110
3.23	The auditory system	113
3.24	(a) The dorsal column–medial lemniscal system of the somatosensory system; (b) the somatosensory cortex	115
3.25	(a) The gustatory system, from tongue to brain; (b) the primary and secondary taste areas in the cortex	116
3.26	The olfactory system	117
3.27	Motor tract pathways	119
3.28	Cortical motor areas	120
4.1	Asymmetry of the face revealed by constructing composite faces in which the face is made up of the same two sides	126
4.2	The areas of the brain involved in language tasks, according to recent neuroimaging data	130
4.3	A typical rotation task. Which of the four alternatives represents the cubes on top?	131

4.4	Another rotation task. The task is to decide whether each set of cubes is the same or different	132
4.5	The areas of the brain involved in imagery tasks, according to recent neuroimaging data	134
4.6	The areas of the brain involved in attention, according to recent neuroimaging data	136
4.7	Two visuospatial tasks on which sex differences are found. In (a), the task is to indicate whether the shape on the card is the same as the stimulus; in (b), the task is to indicate which glove the target glove represents	139
4.8	The divisions of the corpus callosum	147
4.9	Location of the corpus callosum in the brain	147
4.10	The longevity of left- and right-handed cricketers	159
5.1	Geography of the frontal lobes	164
5.2	A card-sorting task similar to the Wisconsin Card Sorting Task. The symbols on the cards can vary by type, number or colour.	168
5.3	(a) The original Tower of Hanoi task. The participant's task is to recreate the arrangement of the discs in the model (top) from the starting position (bottom) in as few moves as possible moving only one disc at a time. A larger disc cannot be placed on a smaller one, and discs cannot be placed outside the posts (e.g. on the table). (b) The Tower of London task. The arrangement on the left is the starting point. The other three positions must be reached from this starting point. The second arrangement can be achieved in a minimum of two moves, the third in a minimum of four and the last one in a minimum of five	169
5.4	(a) The plan of St Andrew's Hospital, Northampton, used in Knight <i>et al.</i> 's (2002) study. The numbers and letters refer to specific locations; (b) the participants' instruction sheet from the same study	170
5.5	The MRI scan of Goldstein <i>et al.</i> 's patient. Note the large lesion in the left frontal cortex (MRI scans are read as mirror images – left is right, and right is left)	179
5.6	The different conditions (bound and separate) in Prabhakaran <i>et al.</i> 's (2000) study	182
5.7	(a) The vocabulary knowledge of JB during the retrograde (left) and anterograde (right) periods; (b) JB's cued autobiographical memory in the same period	183
5.8	Areas of activation in successful recognition memory using fMRI	185
5.9	Phineas Gage's skull	195
5.10	The area of damage to NM's frontal cortex	199
6.1	An example of one of HJA's elaborate drawings and line drawings of simple objects. HJS is unable to name either	217
6.2	Areas of brain activation observed during the viewing of tools (darker areas) and animals (lighter areas), using fMRI	223
6.3	The locations of (a) the parahippocampal place area and (b) the fusiform gyrus or human face area	228
6.4	Areas of activation seen in the experts and non-experts when viewing <i>Lepidoptera</i> and familiar faces	229
6.5	Bruce and Young's model of face processing	231
6.6	A meta-model of face recognition proposed by Schweinberger and Burton (2003)	232
6.7	A spatial neglect patient's performance on the line bisection task	237
6.8	A spatial neglect patient's performance on a line cancellation task	237
6.9	An example of a neglect patient's drawing	238
6.10	The well-known asymmetrical clock face drawn by neglect patients	238

6.11	Maps of the familiar piazzas used in mental imagery tests. The circle containing an arrow indicates the subject's vantage point: the task is to describe what is in front of that point. The black squares indicate those places recalled from mental imagery by neglect patients. They show typical left neglect	240
6.12	(a) Clock drawing performance in spatial neglect patients, with eyes open (i) and eyes closed (ii); (b) drawings of trousers, a truck and a flag, with eyes open (top) and eyes closed (bottom); (c) drawings of a ladder, a pair of glasses and a butterfly, with eyes open (top) and eyes closed (bottom); (d) drawing of a saucepan and a spider, with eyes open (top) and eyes closed (bottom). In these examples, eyes open is associated with greater neglect of the left side of the image	241
6.13	(a) Drawings of a person, butterfly and clock from memory by NT showing absence of neglect; (b) examples of NT's writing, showing neglect	243
6.14	(a) Federico Fellini's MRI scan; (b) and (c) examples of his spatial neglect test performance	248
7.1	An illustration of the possible command apparatus of the parietal lobe	267
7.2	Motor change scores in PD patients who have received foetal grafts in recent studies: (a) changes in motor behaviour across time in six studies of transplantation; (b) changes in blood flow to the supplementary motor area and dorso-lateral prefrontal cortex across time following transplantation	270
8.1	The regions of the brain activated in English and Italian speakers by reading. The differential activation is thought to reflect different reading strategies	278
8.2	The regions of the brain implicated in language processing	280
8.3	The areas of the brain implicated in aphasic symptoms	280
8.4	Some examples of John Hale's writing following his stroke and, inset, his wife Sheila	289
8.5	Some of the brain areas implicated in the process of reading	295
8.6	Some of the brain areas showing activation during the production and comprehension of stories	300
8.7	The performance of dyslexic and control groups on the spatial dot task	306
8.8	The absence of asymmetrical activation in a dyslexic group during motion perception	307
8.9	(a) ERPs from dyslexic readers undertaking a phonological task; (b) ERPs from reading-age-matched controls during performance of the same task	312
9.1	The lifespan of learning consolidation	324
9.2	PET scans of patients with Wernicke–Korsakoff's syndrome	327
9.3	AV's copy of a figure (bottom left) and reproduction of the figure from memory after a delay of 3 and 15 minutes (right-hand side)	330
9.4	JL's MRI scans	332
9.5	The areas of the brain involved in (a) semantic memory retrieval, (b) episodic memory retrieval and (c) episodic memory encoding, according to recent neuroimaging data	334
9.6	The areas of the brain involved in working memory, according to recent neuroimaging data	337
9.7	(a) A model of working memory; (b) the proposed brain pathways involved in phonological working memory	339

10.1	The Papez circuit	349
10.2	The amygdala pathways involved in fear conditioning	350
10.3	Patient SM-046's drawings of various emotional states. Note that she was unable to draw the fear expression	351
10.4	The stimuli used in Morris <i>et al.</i> 's (2002) study and the brain activation observed	353
10.5	The relationship between baseline left- and right-sided EEG activation, and positive and negative affect scores	361
11.1	IM's MRI scans	371
11.2	The presence of the apolipoprotein e4 allele in normal, healthy individuals and in patients with Alzheimer's disease	374
11.3	A model for the aetiology of Alzheimer's disease	375
11.4	(a) Verbal recall performance across four age groups after delays of 20 minutes and 24 hours; (b) recognition memory performance across four age groups after delays of 20 minutes and 24 hours	384
11.5	The dedifferentiation scores of young and old participants in Park <i>et al.</i> 's (2004) study. The higher the bar, the greater the dedifferentiation	386
11.6	Memory test scores for three age groups	388
11.7	Vocabulary scores for three age groups	389
12.1	Models of anxiety and the role of brain regions implicated in anxiety: (a) general; (b) PTSD; (c) specific phobia; (d) social phobia; and (e) panic disorder	408
12.2	The behavioural inhibition system	416
12.3	(a) The septohippocampal system (schematic); (b) a diagrammatic representation of the SHS system	416
12.4	The role of brain regions in the defence system, according to Gray and McNaughton's (2000) model	419
13.1	The development of the human brain	425
13.2	Comparison of (a) the size and (b) the weight of the human brain during development	426
13.3	The burgeoning of connections between neurons and their processes from birth to six years	427
13.4	Axial and coronal views of BL's MRI scans	434
13.5	An example of a timetable kept by Julia C	447
14.1	(a) The Rey Complex Figure; (b) the Taylor Complex Figure and Modified Taylor Figure variants	468
14.2	An example of the Rey figure (a) copied, (b) drawn from memory after three minutes and (c) drawn from memory after 40 minutes	468
14.3	An example from the Raven's Progressive Matrices	471
14.4	The line orientation test: which numbers match the lines above?	472
14.5	The dot localization task: which numbers represent the positions of the dots?	472

- 1.1 Brodmann's cytoarchitectonic map and its functional counterpart
- 1.2 The results of an MEG study showing the areas of the brain controlling fine movement of the hand
- 1.3 CT scan showing brain haemorrhage
- 1.4 (a) Common areas of activation in controls and dyslexic participants who read aloud real words and pseudowords; (b) areas of activation that are greater in controls; (c) areas of activation that are greater in dyslexic participants
- 1.5 PET scans showing activation during seeing, hearing, reading Braille and thinking
- 1.6 (a) Scans showing the regions of brain damage in SW; (b) areas of fMRI activation in SW in a semantic decision task
- 1.7 Coloured MRI scan superimposed on a human head
- 1.8 (a) The stimuli used in Gorno-Tempini and Price's experiment and (b) the areas of activation seen during face and building perception
- 1.9 Areas of stimulation in Nixon *et al.*'s rTMS study of phonological processing
- 3.1 An MRI scan of a brain that has suffered a stroke
- 4.1 PET study of odour imagery. The first scan shows odour imagery minus odour detection; the second shows odour perception minus baseline
- 5.1 Differences in brain activation during verbal and spatial working memory. Scans show those regions showing greater activation during verbal than spatial working memory and during spatial than verbal working memory
- 5.2 The trajectory of the tamping iron through Phineas Gage's head, as recreated by Damasio *et al.* (1994)
- 5.3 Scans showing correlations between extroversion and brain activation during the recognition of happy and fearful facial expressions
- 6.1 A figure showing the eye movement of a hemineglect patient during a visual search task. The figure shows the typical left-sided neglect
- 6.2 The colour neglect seen in a drawing by Blanke *et al.*'s (2003) patient
- 7.1 The brain regions and neurotransmitter systems implicated in Parkinson's disease
- 7.2 Stereotaxic surgery performed to alleviate the symptoms of Parkinson's disease
- 9.1 The route across London that Maguire *et al.*'s (1997) taxi drivers were asked to recall (blue line). The scans show the areas activated by this recall of the route
- 10.1 Amygdala activation in men and women observed in Canli *et al.*'s (2002) study as participants recalled and indicated arousal to emotionally hued pictures
- 11.1 A computer-enhanced photograph of a slice through the brain of a patient with Alzheimer's disease
- 11.2 MRI scan of an individual with Alzheimer's disease
- 11.3 Post-mortem sections of a human brain. The section on the left comes from the brain of an individual with Alzheimer's disease
- 11.4 A neurofibrillary tangle
- 11.5 A senile plaque
- 12.1 Areas of decreased activation in the prefrontal cortex in individuals with mood disorders
- 13.1 Scans showing features of brain development from 5 to 20 years old

Tables

1.1	The number of empirical papers covering specific topics published in <i>Cognitive Neuropsychology</i> between 1998 and 2001	3
3.1	Some terms and prefixes frequently used to describe neuroanatomical direction and position	77
3.2	The six layers of the cortex and the types of cell contained in them	92
4.1	Summary of neuroanatomical asymmetries in the human brain	127
4.2	The Annett Handedness Questionnaire	141
5.1	Summary of some strengths and weaknesses of selected tests of executive dysfunction	171
5.2	Some reflections of frontal lobe patients after their injury	198
6.1	The principal agnosias and their neural basis	215
7.1	Some psychopharmacological treatments for parkinsonism	256
7.2	Some of the tests used to detect apraxic symptoms	264
8.1	(a) Types of aphasia, their primary symptoms and the possible site of the associated brain lesion	281
	(b) Symptomatology of aphasia	281
8.2	The dyslexias	301
8.3	Some of the reading errors made by GR	304
8.4	Some grammatical errors made by patients with cerebellar damage	313
8.5	Types of agraphia, their primary symptoms and the brain regions associated with them	317
12.1	Some of the drugs used to treat depression	405
12.2	Some of the drugs used to treat anxiety	414
14.1	Some common neuropsychological tests and their uses	457
14.2	Examples of the type of item seen on the Mini Mental State Examination	463
14.3	Some computerized tests used in neuropsychological assessment	481

Chapter 1	Neuropsychology: its aims, history and methods	
	Case two of the Edwin Smith Surgical Papyrus	4
	Applying the single-case study approach: the man with the shattered world – the case of Lieut. Zasetzky	13
	Applying the single-case study approach: patient NA and the perils of a miniature foil	14
	Discussion point: what is the point of the single-case study?	17
	Single-case studies	19
	Computational modelling	21
	Applying EEG: chocolate on the brain	23
	EEG	24
	Applying ERP: what's the joke?	25
	Event-related potentials	28
	Applying MEG: sentence comprehension in poor readers	29
	MEG	30
	CT	31
	PET	33
	Combining techniques: cognitive neuropsychology and neuroimaging	34
	MRI	36
	Applying fMRI: where does the brain recognize faces?	37
	fMRI	37
	Discussion point: are neuroimaging studies reliable and valid?	38
	Biochemical techniques	40
	Applying TMS: disrupting the memory for sound	44
	TMS	44
	Applying lateralization techniques: problem solving and the right hemisphere	47
	Lateralization techniques	49
	Discussion point: what is it like to undergo a brain scan?	49
Chapter 2	The brain I: basic neurophysiology	
	Discussion point: can neurons regenerate?	57
Chapter 3	The brain II: basic neuroanatomy	
	Detection by action: the case of MP	109
Chapter 4	Hemispheric localization and lateralization of function	
	Discussion point: can the hemispheres of a split-brain patient still transfer information?	153
	Discussion point: do left-handers die sooner than right-handers?	158

Chapter 5	The frontal lobes: cognition, social behaviour and personality	
	Disorganization in everyday life: the case of EVR	175
	The role of the frontal lobes in encoding: the case of JB	182
	Discussion point: the role of neurochemistry in frontal lobe dysfunction	191
	Are the frontal lobes necessary for theory of mind? The case of GT	193
	Discussion point: where are the neural correlates of personality?	197
	Living with frontal lobe damage, 18 years on: the case of NM	199
	Discussion point: are psychopathy and frontal lobe damage related?	204
Chapter 6	Disorders of perception	
	Deaf hearing: the case of SB	212
	Integrative agnosia: the case of HJA	217
	Prosopagnosia: the case of Adam and others	226
	Discussion point: where does the intact brain 'see' faces?	227
	Developmental neglect dyslexia: the case of NT	243
	Discussion point: how does brain injury affect artists?	246
Chapter 7	Movement disorders	
	Discussion point: can nicotine treat Parkinson's disease?	257
	Discussion point: can neural transplants abolish the symptoms of Parkinson's disease?	268
Chapter 8	The neuropsychology of language and language disorders	
	The man who lost his language: the phenomenology of aphasia	286
	Does aphasia occur in sign language? the case of Charles	290
	Discussion point: does reading Braille activate the same brain regions as normal reading?	298
	Deep dyslexia: the case of GR	303
	Discussion point: do deficits in the cerebellum cause dyslexia?	313
	Discussion point: which brain regions are necessary for reading? Two case studies of acquired dyslexia with neuroimaging	315
Chapter 9	Memory	
	Impaired recall and preserved recognition: the case of ROB	328
	Developmental aphasia: the case of AV	329
	The temporal lobes: the case of HM	330
	Long-term amnesia: the case of JL	332
	The man who forgot the last ten years: the case of PO	335
	The specific impairment of phonological STM: the cases of PV and JB	338
Chapter 10	Emotion – normal aspects	
	Discussion point: the neuropsychology of humour	357

Chapter 11	The dementias	
	The problem of <i>Jackson's Dilemma</i> – dementia and the novelist: the case of IM	369
	Preserved piano-playing in Alzheimer's disease: the case of MD	376
	Discussion point: are the neuropsychological effects of ageing different to those of dementia?	387
Chapter 12	Disorders of thought and mood	
	Discussion point: can Gray's model help to explain human anxiety?	415
Chapter 13	Development and recovery of function	
	Reorganizing language following brain injury: the case of AA	440
	Recovery from aphasia and hemispheric compensation: the cases of HJ, RJ and MJ	441
	Consequences of hemispherectomy: the case of Jamie	444
	Overcoming daily memory problems: the cases of JC and Julia C	446
	Discussion point: can a language-deprived child develop normal language after puberty? The case of Genie	448
Chapter 14	Neuropsychological assessment	
	Discussion point: is neuropsychological assessment culture-free?	474
	Assessing neuropsychological performance in children: the case of Peter	477
	Discussion point: how to identify a patient malingering on a neuropsychological test	481

Preface to the second edition

In the giddy days of 1996 and 1997, when the bulk of the first edition of *Human Neuropsychology* was written, Bill Clinton was coming to the end of his presidency of the United States, to be replaced by a governor from Texas, the UK was still to have its first Labour government in seventeen years, there was no Twin Towers massacre, the Princess of Wales was still alive, and Harry Potter was turning from a glint to a magical image in J.K. Rowling's eye. Momentous events. It is tempting to speculate whether similarly momentous shifts have affected the field of neuropsychology. It is psychology's oldest discipline, so perhaps great change would not be expected. But there have been a few – not in the league of those above, clearly, but a few nonetheless. The most obvious shifts have occurred in the field of neuroimaging.

In Cabeza and Nyberg's (2002) excellent article in *Journal of Cognitive Neuroscience*, they report an almost 150 percent increase in published neuroimaging studies from 1995 to 1998. In 1997, PET was neuroimaging flavour of the month; with the development of fMRI in the early 1990s, the king had been usurped by its more useful prince. In the early 1990s, there was a mini-spat between those who questioned the aims of cognitive neuropsychology. Fast forward to 2004, and *Cognitive Neuropsychology* devotes an entire issue to the same. *O tempora o mores*. Models have been updated (e.g., Gray's septo-hippocampal model of anxiety) and challenged and extended (the anterior asymmetry and emotion model). Scientists think that they have discovered, if not the Holy Grail of neuroscience, then a swatch of its linen in the regeneration of hippocampal neurons.

It is also tempting to assess what we know now that we did not know then: advances in our understanding of the brain regions responsible for face processing, smell and taste, impaired reading, memory encoding and retrieval, and emotional expression are some of the candidate areas. Neuropsychological assessment is a shifting, organic subdiscipline constantly evolving new ways of measuring new constructs (e.g. prospective memory). WAIS-R has been replaced by WAIS-III, which, in turn, will be replaced by WAIS-IV.

Is human neuropsychology healthy? The data suggest that it is (see Martin 2000), although it is just as fractionated as it was: those who study single cases and those who engage in neuroimaging or other technology-based approaches to studying healthy brain activity continue to lead separate lives, although the admirable attempts by those such as Cathy Price to reconcile the two approaches are promising. More facetiously, if the discipline was on an academic life support machine, then you would probably not be reading this now.

The second edition was written in the spring of 2005. There have been some large changes to the first edition. The immediately apparent changes are the physical shape and organization of the book, the inclusion of colour plates, plus the inclusion of two new chapters – memory, and disorders of thought and mood – to rectify the small space given over to these topics previously. Various other chapters have been retitled to reflect a change of emphasis, and the chapters on callosal syndromes and localization of function in the first edition are now one congenial chapter. All chapters have been updated, most substantially. Although not intended to be seen as such, there was a perceived view in some quarters that the first edition of the text was overly biological. In this edition, Chapters 2 and 3 have been pruned and more theoretical material introduced elsewhere (in, for example, the language chapter). This edition also includes special boxed-off case

study features in which an important or novel case study is described and used to illustrate or explore an aspect of human behaviour. There are over thirty of these in the new edition. The ‘discussion points’ in the first edition are also included and extended, and the further reading sections have been subsectioned and amplified. However, the emphasis, as ever, is on what the human brain does and why and how.

I’m always delighted to hear from readers. Drop me a line. My email address is n.martin@mdx.ac.uk

As with the first edition, this second edition has benefited from the advice or practical assistance of a number of friends and colleagues. I would like to thank them here. In alphabetical order, they are Vicki Anderson (University of Melbourne, Australia), Jane Barnett (Middlesex University, UK), Brian Brunswick, Turhan Canli (University of Stanford, USA), Sylvie Chokron (CNRS, France), Julia Cogan, Seana Coulson (University of California at San Diego, USA), John Crawford (University of Aberdeen, UK), Sergio Della Sala (University of Edinburgh, UK), Paul de Mornay Davies (Middlesex University, UK), Jelena Djordjevic (Montreal Neurological Institute, Canada), Nigel Foreman (Middlesex University, UK), Peter Garrard (Institute of Cognitive Neuroscience, UCL, UK), Sheila Hale, Nitin Gogtay (Child Psychiatry Branch, NIMH, USA), Glyn Humphreys (University of Birmingham, UK), Caroline Knight (St Andrew’s Hospital, Northampton, UK), Judy McSorley (Middlesex University, UK), Martijn Meeter (Vrije Universiteit Amsterdam, the Netherlands), Philip Nixon (University of Oxford, UK), Tom Nugent (Child Psychiatry Branch, NIMH, UK), Michael Oddy (Brain Injury Rehabilitation Trust, UK), Doug Potter (University of Keele, UK), Cathy Price (University College London, UK), Scott Rauch (University of Harvard, USA), Gill Rhodes (University of Western Australia, Australia), Nicola Starkey (University of Central Lancashire, UK), Diana Vanlancker-Sidtis (New York University, USA), John D. Williams (University of Coventry, UK) and Rodger L. Wood (University of Swansea, UK).

There are some people I would like to thank especially: Dr Nicky Brunswick, my friend, colleague and co-author at Middlesex, who co-wrote Chapter 8 on the neuropsychology of language; Morten Fuglevand, an editor no author should be without, and the reason this edition looks so much better than the first; Karen McLaren, production editor *par excellence*; Sarah Wild; and Emma Travis (who has since gone on to magnificently glamorous things). Thanks, too, to Nikki.

Finally, and importantly, thanks to you for buying or recommending this book.

*Dr G. Neil Martin
London 2005*

Preface to the first edition

The United States Congress has declared the 1990s to be the Decade of the Brain. New advances and theoretical perspectives in neuroscience research are making this field a popular one both with scientists and with the public imagination. No other machine is so precious and yet so poorly understood as the brain. Like most problems in science, the answers that studies of the human brain yield provoke only further, more interesting questions. A decade of attention will not be sufficient to understand even the simplest of the human brain's processes, but it is a beginning.

The study of human neuropsychology, part of the grand edifice that is modern neuroscience, has blossomed in the past two decades. Much of this expansion in research and interest has been driven by newer and better neuromedical techniques of investigation. Twenty years ago, for example, it would have been impossible to perform a brain scan such as that undertaken during PET imaging while a subject completed a psychological task. Such methods did not exist in workable form. In terms of human brain anatomy, our scientific predecessors relied on very crude *post mortem* dissection and staining measures to determine changes in brain structure and their relation to function. Twenty-five years ago, computerized axial tomography (CT) scans – the brain's own X-ray images – afforded an improved method for observing the human brain's living structure. Today, we have a much superior method in magnetic resonance imaging (MRI), which does a similar job, only better. In future, we look forward to functional magnetic resonance imaging, which can be used to investigate brain function and not merely structure. These brain-imaging techniques, together with measures of the brain's electrical activity such as the electroencephalogram (EEG), arm the neuroscientist with a formidable battery of methods and techniques that can be used to study the neuropsychology of the living human brain.

The meat and drink of neuropsychology, however, have traditionally been the study of those individuals with brain injury. Famous case histories in neuropsychology are a colourful, fortuitous catalogue of the woefully and astonishingly brain-damaged. Who would have imagined that a diseased brain or a brain that had been penetrated by a fencing foil or damaged because of surgery to alleviate epilepsy could have provided science with insights, if that is the correct word, into the relationship between the human brain and its function? Yet these case studies did, and in the following chapters you will learn more about these individuals and others like them. Of course, they are often unique. It is not every person who, like Phineas Gage, has most of his frontal lobes demolished by having an iron rod propelled through his head. But these case studies frequently provide the fillip for theory, further research and new conceptions in neuropsychological science. Such accidents, should they occur often enough, provide more than simply a terrible anecdote: they help to shape the way in which we think that the human brain works.

Human Neuropsychology aims to provide an up-to-date introduction to the issues and problems arising in modern neuropsychology. Knowledge concerning the neuroanatomy and neurophysiology of the human brain, the neuropsychology of the senses, motor disorders, sensory disorders, functional asymmetry, social behaviour, cognition, normal and abnormal emotion, degenerative diseases, development and recovery of function and neuropsychological assessment is drawn from a vast pool of data, including studies of healthy and clinical samples. The thirteen chapters of this book could form the basis of a semesterized course. The first three chapters provide an introduction to the subject, reviewing the history of

neuropsychology and its methods and providing a brief background to the neurophysiology and neuroanatomy of the brain. Readers unfamiliar with the brain, its structure and its workings should familiarize themselves with these chapters before reading the others, as the later chapters assume a rudimentary knowledge of these topics. Readers who are already familiar with these topics might like either to forgo these chapters or to read them for revision.

Most of the topics covered in the book will be included in any traditional neuropsychology course, and some other topics are included that often do not make it onto these courses but are meaningful in a neuropsychological context nonetheless. A resurgence of interest in cognitive neuropsychology has occurred in the past twenty years, and this is reflected in the content of some of these chapters.

The appendix provides a list of resources which you will find useful in your search for further information about human neuropsychology. Important journals in the discipline which you should try to consult regularly are listed, as are software programs which teach you about the neurochemistry, neurophysiology or neuroanatomy of the brain and its functions. Perhaps the most explosive information resource in recent years has been the Internet, the global electronic information network. The appendix lists the addresses and brief content summaries of the best of the websites which provide information about neuropsychology. Like many Internet innovations, there is no guarantee that when you read this book these sites will still be in operation, but those listed have been operating for some time and look as if they will be in the future.

All knowledge is informed by its past and shaped by its context, and this book is no exception. I am indebted to the following individuals who have either commented on draft chapters or offered their assistance and expertise in many other welcome and charitable ways. In alphabetical order, they are Alan A. Beaton (University College of Swansea, UK), Vicki Bruce (University of Stirling, UK), Alan Glass (University of Birmingham, UK), Mark Coulson (Middlesex University, UK), Antonio Damasio (University of Iowa, USA), Hanna Damasio (University of Iowa, USA), Romy and George Dunbar (University of Warwick, UK), Uta Frith (MRC Cognitive Development Unit, UK), Laura A. Goldstein (Institute of Psychiatry, UK), Jeffrey A. Gray (Institute of Psychiatry, UK), Monika Harvey (University of Bristol, UK), Peter W. Halligan (University of Oxford, UK), Graham Hole (University of Sussex, UK), Doreen Kimura (University of Western Ontario, Canada), Joseph LeDoux (New York University, USA), Judy McSorley (Middlesex University, UK), Denis Parker (Glasgow Caledonian University, UK), Anne-Marie Parr (Institute of Psychiatry, UK), Luigi Pizzamiglio (University of Rome, Italy), John Polich (Scripps Research Institute, USA) and Bernard Schiff (University of Toronto, Canada).

An especial thank you is reserved for Nicky Brunswick (Wellcome Department of Cognitive Neurology, London), who not only wrote Chapter 9 on the neuropsychology of language and language disorders but provided invaluable material assistance and immeasurable help during the book's gestation. It is in no small part that this book was made possible by her.

I would also like to acknowledge the influence of and to thank those teachers who, whether they knew it or not, encouraged the production and intellectual shape of this book: Colin D. Gray, Maureen Lewis and Denis Parker. Finally, I would like to thank both Rupert Knight and Christina Wipf Perry, my editors at Prentice Hall, for their help and encouragement.

It is customary to end a personal acknowledgement section with the admission that any errors and flaws left in the book are the author's own. This custom is honoured here. I hope, however, that the influence of the above individuals will have made the author's shortcomings less obvious.

*G. Neil Martin
London 1997*

Acknowledgements

We are grateful to the following for permission to reproduce copyright material:

Figure 1.1 from *The Edwin Smith Surgical Papyrus*, Vol. 2, Plates XVII and XVIII, University of Chicago Press (Breasted, J. H. 1930), Courtesy of the Oriental Institute of the University of Chicago; Figures 1.2 and 1.4 from *Behavioral Neurology and Neuropsychology*, © The McGraw-Hill Companies, Inc., New York (Feinberg, T. E. and Farah, M. J. (eds) 1997); Figure 1.3 from Stock Montage; Figure 1.6 from *Classic Cases in Neuropsychology II*, Psychology Press, Taylor and Francis Group (Code, C., Wallesch, C. W., Joannette, Y. and Lecours, A. R. (eds) 2003); Figure 1.8 A.J. Photo/Hop American/Science Photo Library; Figure 1.10 reprinted from *Neuropsychologia*, Vol. 43, Coulson, S. and Williams, R. F., Hemispheric asymmetries and joke comprehension, pp. 128-141, © 2005, with permission from Elsevier; Figures 1.12 and 1.13 John Polich, Ph.D., Cognitive Electrophysiology Laboratory, The Scripps Research Institute; Figures 1.14, 4.2, 4.5, 4.6, 9.5 and 9.6 from *Imaging cognition II: and empirical review of 275 PET and fMRI studies*, *Journal of Cognitive Neuroscience*, Vol. 12, 1, MIT Press Journals (Cabeza, R. and Nyberg, L. 2000), by permission of Professors Cabeza and Nyberg and MIT Press Journals, © 2000 by the Massachusetts Institute of Technology; Figures 1.16, 3.7, 3.11, 3.14, 3.15, 3.23, 3.26, 3.27 and 7.1 from *Foundations of Physiological Psychology*, 3rd edition, Allyn and Bacon, © 1995 by Pearson Education (Carlson, N. R. 1995); Figure 1.17 University of Durham/Simon Fraser/Science Photo Library; Figure 1.21 from *Getting the right idea: semantic activation in the right hemisphere may help solve insight problems*, *Psychological Science*, Vol. 9, 6, Blackwell Publishing (Bowden, E. M. and Beeman, M. J. 1998); Figures 2.1–2.9, 3.1, 3.6, 3.12, 3.13, 3.18, 3.19, 3.20, 3.24, 3.28 and 10.1 from Kandel, E.R., Schwartz, J.H. and Jessell, T.M., *Essentials of Neural Science and Behaviour*, © 1995, McGraw-Hill/Appleton & Large, reproduced with permission of The McGraw-Hill Companies; Figures 3.2, 3.4, 3.8 and 3.9: 'Figures 1, 2, 12, 27', from *Structure of the Human Brain: A photographic Atlas 3/E* by S.J. DeArmond, M.M. Fusco and M.M. Dewey, copyright © 1974, 1976, 1989 by Oxford University Press, Inc. Used by permission of Oxford University Press, Inc.; Figure 3.10 from Parietal lobe: from action organization to intention understanding, *Science*, Vol. 308, AAAS (Fogassi, L., Ferrari, P.F., Gesierich, B., Rozzi, S., Chersi, F. and Rizzolatti, G. 2005); Figure 3.17 from Barr, M.L. and Kiernan, J.A., *The Human Nervous System*, fifth edition, Lippincott, Williams & Wilkins (1988); Figures 3.21, 3.25a, 5.2 from *Biopsychology*, 3rd edition, Allyn and Bacon (Pinel, John P.J. 1997); Figure 3.22 from *Detection by action: neuropsychological evidence for action-defined templates in search*, *Nature Neuroscience*, Vol. 4, 1, Nature Publishing Group (Humphreys, G. W. and Riddoch, M. J. 2001), by permission of the publisher and Professor Humphreys; Figures 4.3 and 4.4 from *Mental rotation of three-dimensional objects*, *Science*, Vol. 171, AAAS (Shepard, R.N. and Metzler, D. 1971); Figure 4.7 from Doreen Kimura, *Sex and Cognition*, MIT Press, (1999) by permission of the publisher and Doreen Kimura; Figure 4.10 from *Evidence for longevity differences between left handed and right handed men: an archival study of cricketers*, *Journal of Epidemiology and Community Health*, Vol. 47, 3, BMJ Publishing Group (Aggleton, J.P., Kentridge, R.W. and Neave, N.J. 1993); Figure 5.1 from *A Handbook of Neuropsychological Assessment*, Crawford, J.R., Parker, D.M. and McKinlay, W.W., 1992, Psychology Press, Taylor and Francis Group; Figure 5.3a from Bishop, D. V. M., Aamodt-Leeper, G., Creswell, C., McGurk, R. and Skuse, D. H. (2001), *Individual differences in cognitive planning on the Tower of Hanoi task: neuropsychological maturity or measurement error?* *Journal of Child Psychology and Psychiatry*, Vol. 42 (4), Blackwell Publishing Ltd; Figure 5.4 from *Development of a simplified version of the multiple errands test for use in hospital settings* *Neuropsychological Rehabilitation* Vol. 12 (3), (Knight, C., Alderman, N. and Burgess, P.W. 2002), by kind permission of Psychology Press. www.psychologypress.co.uk/journals.asp, 2005, and also with the permission of Caroline Knight; Figure 5.5 from *Unilateral frontal lobectomy can produce strategy application disorder*, *Journal of Neurology, Neurosurgery and Psychiatry*, Vol. 56, BMJ Publishing Group (Goldstein, L. H., Bernard, S., Fenwick, P.B.C., Burgess P.W. and McNeil, J. 1993); Figure 5.6 from *Integration of diverse information in working memory within the frontal lobe*, *Nature Neuroscience*, Vol. 3 (1), pp. 85–90, Nature Publishing Group (Prabhakaran, V., Narayanan, K., Zhao, Z. and Gabrieli, J.D.E. 2000); Figure 5.7 from *Encoding and the frontal lobes: a dissociation between retrograde and anterograde memories*, *Cortex*, Vol. 39 (4/5), pp. 791–812, Figures 1 and 3 (Ward, J. 2003); Figure 5.8 from *Regional brain activations predicting subsequent memory success: an event-related fMRI study of the influence of encoding tasks*, *Cortex*, Vol. 39 (4/5), pp. 1009–1026, Figure 2 (Fletcher, P.C., Stephenson, C.M.E., Carpenter, T.A., Donovan, T. and Bullmore, E.T. 2003); Figure 5.9 from *The return of Phineas Gage: clues about the brain from the skull of a famous patient*, *Science*, Vol. 264, pp. 1102–1105, AAAS (Damasio, H., Grabowski, T., Frank, R., Galaburda, A.M. and Damasio, A.R. 1994) with permission of the publisher and Hannah Damasio; Figure 5.10 from *Relationships between measured cognitive ability and reported psychosocial activity after bilateral frontal lobe injury: an 18-year follow-up*,

Neuropsychological Rehabilitation, Vol. 14 (3), (Wood, R. and Rutterford, N.A. 2004) by kind permission of Psychology Press. www.psychologypress.co.uk/journals.asp, 2005, and also with the permission of Professor Wood; Figure 6.1 from *To See or Not to See: A Case Study of Visual Object Processing*, Humphreys, G.W. and Riddoch, M.J., 1987, Psychology Press (Taylor and Francis Group), and also with the permission of Professor Halligan; Figure 6.2 reprinted from *Current Opinion in Neurobiology* Vol. 11, Martin, A. and Chao, L.L., Semantic memory and the brain: structure and processes, pp. 194–201, Copyright © 2001, with permission from Elsevier; Figure 6.4 from Is the fusiform face area specialized for faces, individuation, or expert individuation? *Journal of Cognitive Neuroscience*, Vol. 16 (2), MIT Press Journals (Rhodes, G., Byatt, G., Michie, P.T. and Puce, A.) © 2004 The Massachusetts Institute of Technology; Figure 6.5 from Understanding face recognition, *British Journal of Psychology*, Vol. 77 (Bruce, V. and Young, A. 1986). Reproduced with permission from the British Journal of Psychology © The British Psychological Society; Figure 6.6 from Covert recognition and the neural system for face processing, *Cortex*, Vol. 39 (1), pp. 9–30, Figure 1 (Schweinberger, S.R. and Burton, A.M. 2003); Figures 6.7, 6.8, 6.9, 6.10 from Current issues in spatial neglect: an editorial introduction, *Neuropsychological Rehabilitation*, Vol. 4, (Halligan, P. and Marshall, J. 1994) by kind permission of Psychology Press. www.psychologypress.co.uk/journals.asp, 2005; Figure 6.11 reprinted by permission from Macmillan Publishers Ltd: *Nature*, Vol. 364, Unilateral neglect restricted to visual imagery, (Guariglia, C., Padovani A., Pantano, P. and Pizzamiglio, L.), Copyright © 1993; Figure 6.12 from The role of vision in spatial representation, *Cortex*, Vol. 40 (2), pp. 281–90, Figures 1, 3, 5 and 6 (Chokron, S., Colliot, P. and Bartolomeo, P. 2004); Figure 6.13 from Developmental neglect dyslexia in a Hebrew-reading child, *Cortex*, Vol. 40 (2), pp. 301–13, Figures 4b and 6 (Friedmann, N. and Nachman-Katz, I. 2004); Figure 6.14 from Preserved insight in an artist with extrapersonal spatial neglect, *Cortex*, Vol. 34 (2), pp. 163–89, Figures 1, 2 and 3 (Cantagallo, A. and Della Sala, S. 1998); Figure 7.2 reprinted from *Trends in Neurosciences*, Vol. 28 (2), Winkler, C., Kirik, D. and Björklund, A., Cell transplantation in Parkinson's disease: how can we make it work? pp. 86–92, Figure 1, Copyright © 2005 with permission from Elsevier; Figure 8.1 from Sound and meaning: how native language affects reading strategies, *Nature Neuroscience*, Vol. 3 (1), Nature Publishing Group (Fiez, J. 2000), and also with the permission of Dr J. Fiez; Figure 8.4 from *The Man Who Lost His Language*, Hale, S., 2003, by kind permission of Sheila Hale; Figure 8.6 reprinted from *Neuropsychologia*, Vol. 42 (10), Mar, R.A. The neuropsychology of narrative: story comprehension, story production and their interrelation, pp. 1414–34, Figure 1, Copyright © 2004, with permission from Elsevier; Figure 9.1 from Consolidation of long-term memory: evidence and alternatives, *Psychological Bulletin*, Vol. 130 (6), pp. 843–857, Figure 1, APA, (Meeter, M. and Murre, J.M.J. 2004) with kind permission of Dr M. Meeter, Faculteit der Psychologie en Pedagogiek, Amsterdam, American Psychological Association, reprinted with permission; Figure 9.2 from FDG-PET findings in the Wernicke-Korsakoff Syndrome, *Cortex*, Vol. 39 (4/5), pp. 1027–45, Figure 2 (Reed, L. J., Lasserson, D., Marsden, P., Stanhope, N., Stevens, T., Bello, F., Kingsley, D., Colchester, A. and Kopelman, M. D. 2003); Figure 9.3 from A case of amnesia at an early age, *Cortex*, Vol. 39 (4/5), pp. 605–25, Figure 6 (Brizzolaro, D., Casalini, C., Montanaro, D. and Posteraro, F. 2003); Figure 9.4 from Long-term amnesia: a review and detailed illustrative case study, *Cortex*, Vol. 39 (4/5), pp. 567–603, Figure 1 (Mayes, A.R., Isaac, C.L., Holdstock, J.S., Cariga, P., Gummer, A. and Roberts, N. 2003); Figure 10.2 from LeDoux, J., In search of an emotional system in the brain: leaping from fear to emotion and consciousness, *The Cognitive Neurosciences*, The MIT Press (Gazzaniga, M.S. (ed.) 1995); Figure 10.3 from Fear and the human amygdala, *Journal of Neuroscience*, Vol. 15, Society of Neuroscience (Adolphs, R., Tranel, D., Damasio, H. and Damasio, A.R.). Copyright © 1995 by the Society for Neuroscience; Figure 10.4 reprinted from *NeuroImage*, Vol. 17, Morris, J.S., deBonis, M., and Dolan, R.J., Human amygdala responses to fearful eyes, pp. 214–222, Copyright © 2002, with permission from Elsevier; Figure 10.5 from Affective neuroscience and psychophysiology: toward a synthesis, *Psychophysiology*, Vol. 40, pp. 655–655, Figure 1, Blackwell Publishing (Davidson, R.J. 2003); Figure 11.1 from Figure 1, The effects of very early Alzheimer's disease on the characteristics of writing by a renowned author, *Brain*, 128, pp. 250–60 by Garrard, P. Maloney, L.M., Hodges, J.R. and Patterson, K., copyright © 2005 by Oxford University Press. Used by permission of Oxford University Press; Figure 11.2 reprinted from *Trends in Neuroscience*, Vol. 27 (10), Teter, B. and Finch, C.E., Caliban's heritage and the genetics of neuronal aging, pp. 627–632, Figure 1, Copyright © 2004, with permission from Elsevier; Figure 11.4 from Acquisition, recall, and forgetting of verbal information in long-term memory by young, middle-aged, and elderly individuals, *Cortex*, Vol. 39 (4/5), pp. 1063–1091, Figs 7 and 9 (Davis, H. P., Small, S. A., Stern, Y., Mayeux, R., Feldstein, S. N. and Keller, F. R. 2003); Figure 11.5 from Aging reduces neural specialization in ventral visual cortex, *Proceedings of the National Academy of Sciences of the United States of America*, Vol. 101 (35), pp. 13091–95, Figure 4, (Park, D.C., Polk, T.A., Park, R., Minear, M., Savage, A. and Smith, M.R.) Copyright © 2004 National Academy of Sciences, USA; Figures 11.6 and 11.7 from Does it all go together when it goes? The nineteenth Bartlett memorial lecture, *Quarterly Journal of Experimental Psychology*, Vol. 46A, (Rabbitt, P. 1993) by kind permission of the Experimental Psychology Society, www.psychologypress.co.uk/journals.asp, 2005, <http://www.eps.ac.uk/journals.html>, 2005; Figure 12.1 from Neural circuitry of anxiety: evidence from structural and functional neuroimaging studies, *Psychopharmacology Bulletin*, Vol. 37 (4), Figs 1-5, Medworks Media, (Cannistraro, P.A. and Rauch, S.L. 2003); Figure 12.2, by kind permission of Professor McNaughton, (original 1.1): From Gray and McNaughton (2000) adapted from Gray (1982) with the permission of the late Jeffrey Gray; Figure 12.3a

from *The Neuropsychology of Anxiety: An enquiry into the functions of the septo-hippocampal system*, 1st edition, Oxford University Press (Gray, J.A. 1982) by kind permission of Mrs V. Gray; Figure 12.4: Figure 1.8 (p. 30) from *The Neuropsychology of Anxiety* 2nd edition by Gray, J.A. and McNaughton N. (2003), by permission of the Oxford University Press; Figure 13.1 from The development of the brain, *Scientific American*, Vol. 241, p. 116 (Cowan, W.M. 1979), illustration by Tom Prentiss, by kind permission of Nelson H. Prentiss; Figure 13.2b from Changes in brain weights during the span of human life: relation of brain weight to body heights and body weights, *Annals of Neurology*, Vol. 4, John Wiley & Sons (Dekaban, A.S. and Sadowsky, D. 1978). Copyright © 1978 Dekaban and Sadowsky. Reprinted with the permission of John Wiley & Sons, Inc.; Figure 13.3 Reprinted by the permission of the publisher from *The Postnatal Development of the Human Cerebral Cortex*, Vols. 1–VIII by Jess Leroy Conel, Cambridge, Mass.: Harvard University Press, Copyright © 1939, 1975 by the President and Fellows of Harvard College; Figure 13.4 reprinted from *Brain and Language*, Vol. 91, Vanlancker-Siddis, D., When only the right hemisphere is left: studies in language and communication, pp. 199–211, Figure 1, Copyright © 2004, with permission from Elsevier; Figure 13.5 from Coping with severe memory impairment, *Neuropsychological Rehabilitation*, Vol. 14 (5), (Oddy, M. and Cogan, J. 2004) by kind permission of Psychology Press. www.psychologypress.co.uk/journals.asp, 2005, and also with the permission of Michael Oddy; Figure 14.2 with permission from Dr Anita Hubley; Figure 14.3 reprinted from *Intelligence* Vol. 33 (1), Blair, C., Gamson, D., Thorne, S. and Baker, D., Rising mean IQ: cognitive demand of mathematics education for young children, population exposure to formal schooling, and the neurobiology of the prefrontal cortex, pp. 93–106, Figure 2, Copyright © 2005, with permission from Elsevier; Photo of Iris Murdoch on p. 370 © Bassouls Sophie/Corbis Sygma.

Plate 1.1 from <http://spot.colorado.edu/~dubin/talks/brodman/brodman.html>, by kind permission of Professor Mark Dubin, University of Colorado; Plate 1.2 Hank Morgan/Science Photo Library; Plate 1.3 BSIP, Cavallini James/Science Photo Library; Plate 1.4 reproduced by kind permission of Dr Nicky Brunswick; Plate 1.5 Wellcome Dept. of cognitive Neurology/Science Photo Library; Plate 1.6 (a) and (b) from Delineating necessary and sufficient neural systems with functional imaging studies of neuropsychological patients, *Journal of Cognitive Neuroscience*, Vol. 11, MIT Press Journals (Price, C.J., Mummery, C.J., Moore, C.J., Frackowiak, R.S.J. and Friston, K.J.) © 1999 The Massachusetts Institute of Technology; Plate 1.7 Geoff Tompkinson/Science Photo Library; Plate 1.8 from Identification of famous faces and buildings: a functional neuroimaging study of semantically unique items, *Brain*, Vol. 124, pp. 2087–97, Oxford University Press (Gorno-Tempini, M.L. and Price, C.J. 2001), by permission of Oxford University Press; Plate 1.9 from The inferior frontal gyrus and phonological processing: an investigation using rTMS, *Journal of Cognitive Neuroscience*, Vol. 16 (2), MIT Press Journals (Nixon, P., Lazarova, J., Hodinott-Hill, I., Gough, P. and Passingham, R.) © 2004 The Massachusetts Institute of Technology; Plate 3.1 Simon Fraser/Royal Victoria Infirmary, Newcastle upon Tyne/Science Photo Library ; Plate 4.1 from *NeuroImage*, Vol. 24, Djordjevic, J., Zatorre, R.J., Petrides, M., Boyle, J.A. and Jones-Gotman, M., Functional neuroimaging of odor imagery, pp. 791– 801, Figure 7, Copyright © 2005, with permission from Elsevier; Plate 5.1 from Evidence for quantitative domain dominance for verbal and spatial working memory in frontal and parietal cortex, *Cortex*, Vol. 39, pp. 897–911, Figure 3 (Walter, H., Bretschneider, V., Grön, G., Zurowski, B., Wunderlich, A.P., Tomczak, R. and Spitzer, M. 2003); Plate 5.2 from The return of Phineas Gage: clues about the brain from a famous patient, *Science*, Vol. 264, pp. 1102–5, AAAS, (Damasio, H., Grabowski, T., Frank, R., Galaburda, A.M. and Damasio, A.R. 1994) with permission of the publisher and Hanna Damasio, Department of Neurology and Image Analysis, University of Iowa College of Medicine; Plate 5.3 from Amygdala response to happy faces as a function of extraversion, *Science*, Vol. 296, p. 2191, AAAS, (Canli, T., Sivers, H., Whitfield, S.L., Gotlib, I.H. and Gabrieli, J.D.E. 2002); Plate 6.1 from Impaired spatial working memory: one component of the visual neglect syndrome? *Cortex*, Vol. 40, pp. 667–676, Figure 4 (Malhotra, P., Mannan, S., Driver, J. and Husain, M. 2004); Plate 6.2 reprinted from *The Lancet*, Vol. 361, Blanke, O., Ortigue, S. and Landis, T., Colour neglect in an artist, p. 264, Copyright © 2003, with permission from Elsevier; Plate 7.1 John Bavosi/science Photo Library; Plate 7.2 BSIP, Astier/Science Photo Library; Plate 9.1 from Recalling routes around London: activation of the right hippocampus in taxi drivers, *Journal of Neuroscience*, Vol 17, p. 7103, Society for Neuroscience (Maguire, E.A., Frackowiak, R.S.J. and Frith, C.D.) Copyright © 1997 by the Society for Neuroscience; Plate 10.1 from Sex differences in the neural basis of emotional memories, *Proceedings of the National Academy of Sciences of the United States of America*, Vol. 99 (16), pp. 10789–94, Figure 2, (Canli, T., Desmond, J.E., Zhao, Z. and Gabrieli, J.D. E.). Copyright © 2002 National Academy of Sciences, USA; Plate 11.1 Alfred Pasiaka/Science Photo Library; Plate 11.2 Zephyr/Science Photo Library; Plate 11.3 Simon Fraser/MRC Unit, Newcastle General Hospital/Science Photo Library; Plate 12.1 reprinted from *Current Opinion in Neurobiology*, Vol. 11, Drevets, W.C. Neuroimaging and neuropathological studies of depressions: implications for the cognitive-emotional features of mood disorders, pp. 240–9, Copyright © 2001, with permission from Elsevier; Plate 13.1 from Dynamic mapping of human cortical development during childhood through early adulthood, *Proceedings of the National Academy of Sciences of the United States of America*, Vol. 101 (21), pp. 8174–8179, Figure 3, (Gogtay, N. et al.). Copyright © 2004 National Academy of Sciences, USA.

In some instances we have been unable to trace the owners of copyright material, and we would appreciate any information that would enable us to do so.

Guided tour

2

The brain I: basic neurophysiology

The nervous system and its two major divisions
Cells in the nervous system
The neuron
The axon and myelination
Different types of neuron
Glial cells
Astrocytes (astroglia)
Oligodendrocytes (oligodendroglia)
Microglial cells
Schwann cells
How neurons communicate I: the action potential
The membrane potential
Depolarisation and hyperpolarisation
How is the nerve impulse transmitted?
How neurons communicate II: neurotransmission
The synapse
What is a neurotransmitter?
Types of neurotransmitter
Acetylcholine
Monoamines (biogenic amines)
GABA
Gamma-aminobutyric acid
Glycine
How is neurotransmission stopped?
Neurogeographical location of neurotransmitters
The simplest of systems?
Summary
Recommended further reading

The nervous system and its major divisions

The greyish, soft, 1400 g jelly-like lamp encased by the skull, together with the 1-cm-thick cord extending from the back of it, provides the fundamental basis for adult human behaviour. The brain is part of the nervous system (NS), the body's mass of interconnecting and interacting nervous tissue. The NS comprises two major parts: the central nervous system (CNS) and the peripheral nervous system (PNS). The CNS consists of neurons

55

A **Contents list** is included at the start of each chapter. This provides an instant reference to the main themes and issues that are about to be explored.

Development and recovery of function 449

her in the adult ability category. She could tell the difference between singular and plural words and positive and negative sentences and could understand some prepositions. Her speech was limited to one- or two-word sentences, however, eventually becoming very descriptive and concrete (big rectangular pillow, very, very, very dark-green box). The 'explosion' of language normally expected after such dramatic improvements never materialised.

What does the story of Genie tell us about the critical period of language? It tells us a certain amount but deprives us of much. It became clear that Genie could develop new but basic language skills. She made a dramatic recovery from the time of her discovery to the time when the scientists had to abandon their studies. Yet her language never fully recovered, remaining stochastically descriptive, almost at the level one would expect primates to achieve with intensive language training. However, her study showed the remarkable, devastating effects of language and auditory deprivation on the development of language ability.

Latest accounts indicate that Genie is still alive and living in a home for retarded adults after her mother had been awarded custody of her. Despite an injunction preventing her from disallowing access to Genie for scientific study, Genie's mother has consistently violated the injunction. Many of the scientists who studied her in the 1970s do not know where she lives and do not know how well she is doing today. Of all the case histories in psychology and in this book, that of Genie is probably one of the most tragic, remarkable and yet informative.

Summary

The human brain undergoes considerable development from birth onwards. At birth, the brain weighs approximately 350 g. By the time it reaches adulthood, it will have quadrupled in weight. The reason for the increase is an expansion of neuron size and connective processes. We are born with all the neurons we will ever have. Characteristics of brain growth include cell migration, the growth of axons, the formation of dendrites and synapses, and myelination. A degree of neural pruning occurs in the first few years of life. Excess connections (especially dendritic) become redundant, as do many synapses. MRI evidence indicates that the brain develops asymmetrically, with right hemisphere grey matter being greater than the left and boys showing larger brains than girls. This difference in size continues through to adulthood. Environmental stimulation is important for the efficient development of the nervous system. Deprivation of visual cues early in life, for example, can have detrimental consequences for the development of the visual system. It has been suggested that there is a critical or sensitive period in development during which functions become lateralised. This sensitive period has been described as developing from birth to puberty or, more likely, from birth to the age of 6 or 6, based on studies showing that if either hemisphere is lesioned before this age, recovery of function is relatively efficient. If the left hemisphere is damaged after that age, the long-term consequences for language function are not good, with severe aphasia occurring. There appear to be two stages in the process of recovery: the immediate reorganization of the nervous system after injury and the subsequent development of new connections and compensatory mechanisms. Recovery from aphasia is reasonably good if the patient is young, left-handed, does not exhibit severe aphasia, and the lesion is not extensive and does not involve many important language-related structures. The age of the patient, the

A **Summary** is included at the end of each chapter to aid revision by supplying a concise synopsis of the main chapter topics.

xxxii

332 Human Neuropsychology

Long-term amnesia: the case of J.L.

Long-term amnesia describes a condition whereby information is normally acquired and retrieved but forgetting is abnormally fast, especially when delays of days or weeks separate encoding and retrieval (Kapur 1993). Delays of 30 s do not impair recall. This contrasts with organic amnesia, where recall and recognition of material can be disrupted by a delay of even a few seconds (Squire and Zola-Morgan 1991).

The abnormal forgetting curve in long-term amnesia suggests that there is some form of impairment in long-term, but possibly not short-term, consolidation of memory. Quick consolidation of episodic and semantic memory appears to rely on the hippocampus and medial temporal lobe, whereas long-term consolidation, a slower process, depends on more widespread neocortical sites, because rehearsal and repetition of material is required (Alvarez and Squire 1994; Nadel and Moscovitch 1997). J.L. suffers from epilepsy – at one point suffering twenty to thirty seizures each month – and shows symptoms of long-term amnesia (Mayes et al. 2003). J.L.'s brain damage is quite diffuse (see Figure 9.4). Following a closed head injury that led to the epilepsy, there were lesions to the superior, middle and inferior temporal gyri, the right amygdala and 75 percent of the right medial/lateral orbito-frontal cortex. When tested, J.L. showed preserved recall and recognition memory 30 minutes after encoding but was significantly impaired at three weeks. J.L. was especially poor at performing visual recognition tasks such as face recognition and presented with mild retrograde amnesia. Not unusual of patients with amygdala damage, J.L. could not recognize fear

Figure 9.4 J.L.'s MRI scan from Mayes et al. (2003)

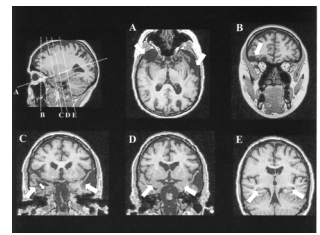

Special interest boxes throughout the text focus on a particular topic to provide a more detailed explanation and provoke further discussion.

450 Human Neuropsychology

site of the lesion, the type of language function observed and the severity of the aphasia all influence the rate and degree of recovery from aphasia. An important point to remember is that many studies may not be comparable owing to differences in these measures. The sparing of function that appears to accompany early brain damage is an example of the Kennard principle: function may be spared if the lesion is made early in life but may be impaired otherwise. The invariance hypothesis suggests that there is left hemisphere specialization of language at birth and that the right hemisphere takes over this function if the left is damaged. The maturation hypothesis argues that both hemispheres are involved in verbal and non-verbal functions from birth, but that the left hemisphere becomes specialized. The parallel-development hypothesis states that the left hemisphere is dominant for verbal functions and the right hemisphere is dominant for non-verbal functions from birth. The evidence would tend to favour the maturation hypothesis. Theories of recovery argue that (1) damage to one part of the brain can affect the functions of other parts of the brain and to one part might inhibit the activity of another part (arrested theories), (2) undamaged regions not specialized for the functions compensate for the impaired function (anatomical reorganization theories), or (3) recovery relies on the adoption of different behavioural strategies to restore function (functional adaptation theories). Rehabilitation refers to the process whereby treatment or therapy encourages the patient to achieve functioning as near to normal as possible. Different rehabilitation techniques are available for language and memory disorders.

Recommended further reading

Development

- Carey, B.J., Tomblin, N., Lison, C. and Davison, S. (2005). Imaging the developing brain: what have we learned about cognitive development? *Trends in Cognitive Sciences*, 9, 3, 164-8.
- Gioldi, J.N., Blumenthal, J., Jeffrey, N.D., Castellanos, F.X., Liu, H., Zijdenbos, A., Paus, T., Evans, A.C. and Rapoport, J.L. (1999) Brain development during childhood and adolescence: a longitudinal MRI study. *Nature Neuroscience*, 2, 10, 861-3.
- Johnson, M.H. (1997). *Developmental Cognitive Neuroscience*. Oxford: Basil Blackwell.
- Johnson, M.H. and Mankata, Y. (2005). Processes of change in brain and cognitive development. *Trends in Cognitive Sciences*, 9, 3, 152-8.
- Johnson, M.H., Mankata, Y. and Gilmore, R.O. (2002). *Brain Development and Cognition: A Reader*. Oxford: Basil Blackwell.
- Leonard, C.M., Lombardino, L.L., Menardo, L.R., Broad, S.R., Bente, J.I. and Agee, O.F. (1996). Cerebral asymmetry and cognitive development in children. *Psychological Science*, 7, 2, 89-95.
- Maree, D., Lewis, T.L. and Moudouli, C.J. (2005). Missing insights: cognitive for visual cognitive development. *Trends in Cognitive Sciences*, 9, 3, 144-151.
- Nelson, C.A. (1999) Neural plasticity and human development. *Current Directions in Psychological Science*, 8, 2, 42-5.
- Rymer, R. (1993). *Genie: Escape from a Silent Childhood*. London: Michael Joseph.
- Special issue of *Developmental Neuropsychology* on 'The biological and social determinants of child development', 2001, 24, 2 and 3.
- Saxe, R., Carey, S. and Kanwisher, N. (2004). Understanding other minds: linking developmental psychology and functional neuroimaging. *Annual Review of Psychology*, 55, 87-124.
- Sowell, E.R., Thompson, P.M., Holmes, C.J., Bath, R., Jernigan, T.L. and Toga, A.T. (1999). Localizing age-related changes in brain structure between childhood and adolescence using statistical parametric mapping. *NeuroImage*, 9, 587-97.

Each chapter is supported by **Recommended further reading**, directing the reader to further information sources.

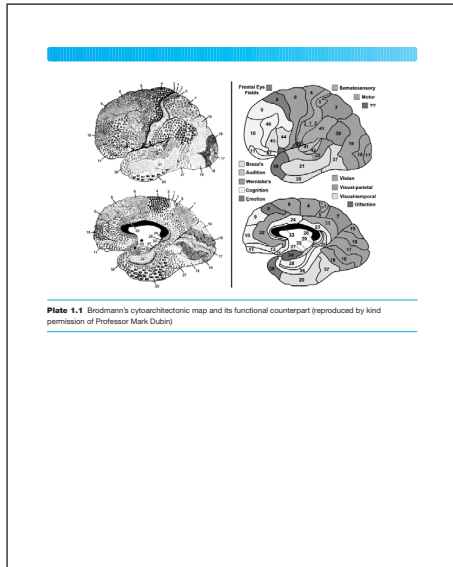

Coloured figures and a full colour plate section in the middle of the book illustrate key topics and processes visually to reinforce learning.

Appendix: resources for neuropsychology students

Sources of information
Journals
Neuropsychology websites and software
Societies

Sources of Information

A number of important resources are available to students of neuropsychology to help you get to grips with the subject. The best and obvious source is reading material, particularly refereed journals that carry interesting empirical research or literature reviews in human neuropsychology. Another source of information is the World Wide Web and computer software. The former is the most advanced resource available to any student. While a lot of what you find on the Internet is quirky or, frankly, rubbish, there are sites that you can visit that offer excellent written and visual resources to any student interested in neuropsychology.

This chapter is designed to provide you with a non-exhaustive list of the types of resource available in human neuropsychology that can help you, as a student, to gain a better understanding of the subject.

Journals

Visit any journal section in any university library and it will seem as if there is a journal covering almost every academic topic imaginable. Publishers have become keen to publish new and more specialized journals, which has resulted in an increase in the number of potential outlets for publishing results and disseminating information. General journals continue to flourish and for good reason: these tend to be the journals that most researchers would like to publish their findings in. Examples include *Nature*, *Neuroscience and Science*. General neuropsychology journals include *Brain*, *Journal of Neuroscience and Neurophysiology*. *Neuropsychologia*, for example, includes papers on topics ranging from olfactory lateralization in chicks to frontal lobe dysfunction and impaired face recognition. Journals such as *Laterality* and *Visual Neuroscience*, on the other hand, limit their coverage to those two aspects of neuropsychology. Often, these specialized journals become leaders in their field.

485

An Appendix at the end of the book provides a comprehensive list of further information sources to aid additional research.



The book's accompanying website at www.pearsoned.co.uk/martin includes multiple choice questions and essay questions for students and PowerPoint slides for lecturers.

Men ought to know that from the brain, and from the brain only, arise our pleasures, joy, laughter and jests, as well as our sorrows, pains, griefs and tears. Through it, in particular, we think, see and hear, and distinguish the ugly from the beautiful, the bad from the good, the pleasant from the unpleasant.

Hippocrates, *The Sacred Disease*, XVII

1

Neuropsychology: its aims, history and methods

Neuropsychology: some history and definitions

The head and the heart

Human neuropsychology: development of the discipline

The fourth to the fourteenth century: the importance of the ventricles

Discoveries in the brain

Neuropsychology's bumpy ride: phrenology

Discoveries of the nineteenth century: Broca and speech production

Discoveries of the nineteenth century: Wernicke and speech comprehension

One dog, two scientists and a German dressing table: the beginning of modern neuropsychology

Mapping brain function: Brodmann and others

From the nineteenth to the twenty-first century

The tools of human neuropsychology: measuring brain function and structure

The single-case study: in-depth exploration of brain injury and disrupted function

Connectionism/neural networks/computational modelling

Electroencephalography (EEG)

Event-related potentials (ERPs)

Magnetoencephalography (MEG)

Computerized tomography (CT)

Positron Emission Tomography (PET)

Single Photon Emission Computerized Tomography (SPECT)

Combining techniques: cognitive neuropsychology and neuroimaging

Magnetic Resonance Imaging (MRI)

Functional Magnetic Resonance Imaging (fMRI)

Biochemical techniques

Brain electrical stimulation

Modern brain stimulation: trans-cranial magnetic stimulation

Lateralization techniques

Summary

Recommended further reading

Neuropsychology: some history and definitions

The key philosophical theme of modern neural science is that all behaviour is a reflection of brain function.

KANDEL 1991

The head and the heart

It is often surprising to discover, in these sophisticated neuropsychological times when the brain's activity can be monitored and captured in coloured, three-dimensional splendour, that this organ was once considered less important than others for maintaining and initiating thought and behaviour. Some ancient philosophers and physicians had very different views of the role of the brain.

Early theories of 'localization of function' focused on the heart as the organ responsible for mediating behaviour. Aristotle (384–322 BC), for example, argued that organs located near the brain were connected to the heart via 'vascular channels' and that the brain existed in order to balance the heart's function, specifically to 'make the heat and the boiling in the heart well blent and tempered'. This viewpoint is called the cardiocentric view: the position that the nerves originated in the heart and that thought and sensation both resided there. Vital spirits were generated by the left chamber of the heart and transferred to the brain, where, via what Aristotle called the *rete mirabile* (a vascular network surrounding a stalk-like brain structure called the pineal gland), they were converted into animal spirits. These animal spirits could then be dispatched to other parts of the body and generate action or sensation.

The notion was challenged by two of the greatest of the Greek physicians, Hippocrates (c. 430–350 BC) and Galen of Pergamum (c. AD 131–201). They argued that the brain was responsible for the behaviour and functions ascribed to the heart. This assumption, the cephalocentric view, was espoused in many of Hippocrates' writings. 'I hold that the brain is the most powerful organ of the human body', he wrote in *The Sacred Disease*, 'eyes, ears, tongue, hands and feet act in accordance with the discernment of the brain'. Earlier observers such as Alcmaeon of Croton (c. 500 BC) had also ascribed functional and behavioural significance to the brain.

While this flash of astonishing and prescient insight might seem to us to be obvious, Hippocrates and his supporters' beliefs were the minority position. Indeed, it was not until the nineteenth century that experimental localization studies confirmed the importance of the brain, and specifically the outer layers of the brain – the neocortex – to human behaviour. Even mediaeval studies had placed greater emphasis on the brain's ventricles, the cavities within the brain, and not its actual inner and outer structure. However, the once minority view is the starting point for modern neuropsychology – the hypothesis that the brain is responsible for the initiation, execution and maintenance of function.

The aim of human neuropsychology is to establish relationships between psychological functions such as motor movement, sensation, cognition, perception, mood and mental illness, and brain activity and structure (Martin 2003). This is sometimes referred to as functional localization. A similar term is functional lateralization, which refers to the proposition that a function may reside in one or either side (or hemisphere) of the brain. The terms functional asymmetry, hemispheric asymmetry and functional lateralization are virtually synonymous.

Neuropsychology has some distinct subareas. One of the more prominent is cognitive neuropsychology, which 'represents a convergence of cognitive psychology and neuropsychology' (Ellis and Young 1996) and, according to McCarthy and Warrington (1990), is a 'hybrid term applied to the analysis of those handicaps in human cognitive function which result from brain injury. Cognitive neuropsychology draws both on neurology and cognitive psychology for insights into the cerebral organisation of cognitive skills and abilities'.

In fact, much of the knowledge regarding impaired cognition and brain function and activity derives from clinical studies of patients with damage to the central nervous

Table 1.1 The number of empirical papers covering specific topics published in *Cognitive Neuropsychology* between 1998 and 2001

Topic	Number of papers
Object recognition and perception	8
Faces	4
Spatial cognition	5
Attention	7
Lexical architecture	1
Reading	16
Writing and spelling	5
Spoken word production	10
Sentence comprehension	2
Memory	4
Semantics	13
Mathematics	2
Music	1
Action	7

system – the brain and spinal cord. Usually single-case studies, these examples illustrate vividly the effects of brain damage on behaviour and function. When considering the neurophysiological basis of language, for example, this type of information is important because animal ablation studies would not be able to give us much information about the neuropsychology of human language. Table 1.1 provides an indication of the topics most commonly studied by cognitive neuropsychologists, based on peer-reviewed empirical articles published in one of the leading neuropsychology journals over a four-year period (Harley 2004). Although clearly not exhaustive, it is a useful reflection of what neuropsychologists consider interesting and relevant subjects.

Together with studies of healthy individuals assessed using modern localizing techniques such as brain imaging, clinical observations help to piece together a coherent picture of brain function. Each type of investigation is potentially complementary.

Human neuropsychology: development of the discipline

Any good science benefits from an understanding of its origins, and human neuropsychology is no exception. One of the earliest documents describing the effects of brain damage on function dates from the seventeenth century BC, although it is probably a copy of an ancient composite manuscript dating from around 3000–2500 BC, supplemented by commentaries (Breasted 1930). This ancient manuscript, called the Edwin Smith Surgical Papyrus after the Egyptologist who discovered it in Luxor, Egypt, in 1862, describes forty-eight observations of brain and spinal injury and its treatment. It is an extraordinary document in that it contains the first description of various parts of the brain, including the cranial sutures, the meninges, the brain's external surface and cerebrospinal fluid (Wilkins 1992); is probably the first scientific document to use the word 'brain'. A copy of the papyrus can be seen in Figure 1.1.

Figure 1.1

An extract from the Edwin Smith Surgical Papyrus (courtesy of the Oriental Institute of the University of Chicago)

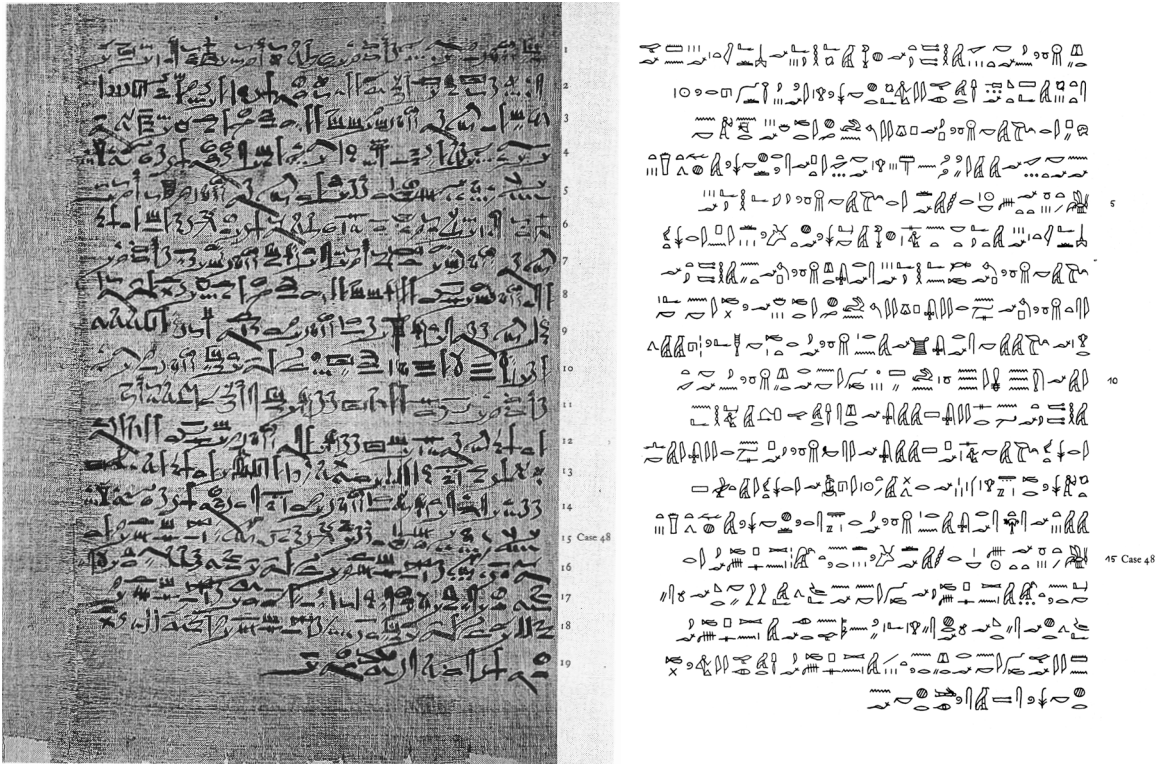

It also contains the first reported case of disorders such as quadriplegia, urinary incontinence, priapism and seminal emission following vertebral dislocation. Most cases are presented in the same format, with title, examination, diagnosis and treatment described. For example, the description in the box below is case two of the papyrus and describes a wound to the head.

Case two of the Edwin Smith Surgical Papyrus

Title: Instructions concerning a [gaping] wound [in his head], penetrating to the bone.

Examination: If thou examinest a man having a [gaping] wound [in] his [head], penetrating to the bone, thou shouldst lay thy hand upon it (and) [thou shouldst] pal[pate hi]js [wound]. If thou findest his skull [uninjured, not hav]ing a perforation in it . . .

Diagnosis: Thou shouldst say regarding [him]: 'One hav[ing a gaping wou]nd in his head. An ailment which I will treat'.

Treatment: [Thou] shouldst bind [fresh meat upon it the first day; thou shouldst apply for him two strips of linen, and treat afterward with grease, honey (and) lin]t every day until he recovers.

Gloss: As for 'two strips of linen,' [it means] two bands [of linen which one applies upon the two lips of the gaping wound in order to cause that one join] to the other.

(from Breasted 1930)

The fourth to the fourteenth century: the importance of the ventricles

Early cephalocentric theories of function, dating back to at least AD 4, had argued that the types of behaviour mediated by the brain were based on activity of the ventricles and the fluid in them. Until around the fourteenth century it could be argued pretty strongly that functional localization in the brain was essentially ventricular localization. In the fourth century AD, the Church fathers had suggested that the anterior ventricles were responsible for perception, the middle ventricles for reason and the posterior ventricles for memory. The gifted anatomist and artist Andreas Vesalius (1514–64) described the principal method of brain dissection, which involved (primarily) exposing the ventricles for observation. However, he did not note any difference between the ventricular volume of humans and that of animals, suggesting that the site responsible for function might be more ‘cerebral’ than ventricular in nature. Figure 1.2 illustrates one representation of ventricular organization.

The quest for the localization of function continued in many guises during the seventeenth and eighteenth centuries. A large part of seventeenth-century endeavours, characterized by the vitality of the Renaissance, revolved around the localization of the seat of the soul or ‘the mind’, although theorists continued to implicate the ventricles. René Descartes (1596–1650), for example, suggested that the pineal gland, a small

Figure 1.2

One system of ventricular organization (from *Behavioral Neurology and Neuropsychology*, T. E. Feinberg and M. J. Farah, 1997, © The McGraw-Hill Companies, Inc.)



brainstem structure, was the ‘seat’ of the soul. Or, rather, it was seen as the place where sensory information would converge and go on to the soul. Separate sense impressions came together here, argued Descartes, ‘before they reach the soul’. Descartes’s localization of the mind/soul, if the most widely known, was not the only attempt to ascribe the localization of mental properties to brain structures. Other candidates for the source of the mind/soul included the corpus striatum, white matter and the corpus callosum, structures described in Chapter 3. Descartes also posited that the interaction between the fluid in ventricles and brain tissue explained intelligent behaviour. The now familiar reflex action described by Descartes and printed in a myriad textbooks (including this one; see Figure 1.3), argued that the stimulation of nerves caused a release of animal spirits in the ventricles, which, in turn, stimulated efferent neurons and muscles and created action. This loop was controlled by the soul, which exerted its effects via the pineal gland (a structure identified because its location in the brain was central and it was surrounded by cerebro-spinal fluid, the liquid that fills the brain’s chambers and crevices).

Discoveries in the brain

The eighteenth and nineteenth centuries saw separate anatomical and neurophysiological discoveries that turned the ventricular hypotheses on their chambered heads. One discovery was that the brain was composed of cells (neurons) that had various functional parts called the cell body, dendrites and axon. Camillo Golgi had discovered a means of tracing the structure of these cells by a form of ‘staining’ involving silver impregnation. These types of stain are called Golgi stains. Under a microscope, such staining showed clearly the structure of the tissues of the brain. This staining technique was used by another brain pioneer, Santiago Ramón y Cajal, who discovered that the brain comprised a network of communicating neurons. Cajal’s enormously influential work led to the formulation of the

Figure 1.3

The withdrawal reflex as conceived by Descartes (from Stock Montage Inc.)



neuron doctrine – the belief that the nervous system is made up of communicating cells or neurons. In recognition of this work, Golgi and Ramón y Cajal jointly won the Nobel Prize for medicine and physiology in 1906.

Another important event, Luigi Galvani's discovery that nerve cells produced electricity, led to Emil DuBois-Reymond and Hermann von Helmholtz's discovery that nerve cells communicated with each other using electrical signals. This was followed by discoveries in psychopharmacology, specifically, the discovery that the surface of neurons – their receptor sites – was responsive to various chemicals called neurotransmitters. The most important of these are described in Chapter 2.

In the seventeenth century, Albrecht van Haller proposed that the nerves that mediated action were also those responsible for sensation. Discoveries were also being made further down the brain, in the spinal cord. Independently, Sir Charles Bell and François Magendie found that roots in one part of the cord undertook sensory functions, whereas roots in another part undertook motor functions (this became known as the Bell–Magendie law).

Neuropsychology's bumpy ride: phrenology

The most seriously proposed, although ultimately ridiculed and disregarded, theory of localization in the nineteenth century was that the brain comprised a number of separate organs, each of which controlled a separate innate faculty and each of which created indentations in the skull. There were said to be twenty-seven of these faculties, including memory of things and facts, sense of spatial relations, vanity, God and religion, and love of offspring. Development of these organs led to prominences or 'bumps' in the individual's skull. A bump on the skull indicated a well-developed underlying cortical gyrus (a raised part of brain tissue) and therefore a greater faculty for a particular behaviour. Conversely, a skull depression was a sign of an undeveloped gyrus and, therefore, a lack of function.

This notion was known as phrenology or anatomical personology and was devised by the Viennese physician and anatomist Franz Joseph Gall (1758–1828) and his co-worker, Johann Caspar Spurzheim (it was Spurzheim who actually coined the term). At the age of 9, Gall had noted that some of his schoolmates who excelled at memory tasks had prominent eyes (*'les yeux a fleur de tête'* or 'cow's eyes') and proposed that this was attributable to overdevelopment of the adjacent regions in the brain. These regions were thought to be involved in language and verbal memory. This hypothesis was developed *in extremis* with phrenology. The theory was based on the analysis of hundreds of skulls, animal and human. In one novel and ingenious theoretical pirouette, they observed that in carnivorous animals there was a bump in the skull above the ear. This was thought to represent disposition to cruelty or murder and, in a test of this hypothesis, Gall and Spurzheim discovered that sadists and famous criminals (as well as the busts and paintings of famous murderers) also exhibited this physical characteristic.

This pseudoscientific theory of localization was easily challenged, however, and equally easily dismissed (as exemplified by the skull of an imbecile, described as belonging to a genius). However, the legacy of phrenology lies in its stark, if misguided, willingness to localize specific functions in specific areas of the brain, an endeavour that is now the aim of modern neuropsychology. Furthermore, although more famously known as the co-progenitor of phrenology, Gall made several other important contributions to neuropsychology. He established the distinction between grey and white matter in the brain, for example, and suggested that damage to the front part of the brain on the left side could lead to an inability to produce or comprehend speech (a condition called aphasia).

However, it is for the ill-fated phrenology that Gall will probably be best remembered.

One of phrenology's fiercest critics was Marie-Jean-Pierre Flourens, a French neurologist who argued that no functional localization occurred in the cerebrum. In a series of experiments to determine the effects of removal of certain parts of the brain on function, he found that it was not the site of the removal that was important but the quantity of tissue removed. In other words, he argued that cerebral matter was equipotential: any part of the brain could perform another's function. This was also known as the aggregate field view of the brain. He noted this especially in birds and animals where recovery was possible following ablation (removal of parts of the brain). The notion of equipotentiality was a strong and popular one at the time. However, it was not long before findings from clinical neurology cast some doubt on the theory's validity.

Discoveries of the nineteenth century: Broca and speech production

In 1861, at the Société d'Anthropologie in Paris, a meeting was held to debate the relative merits and demerits of equipotentiality versus localization. The supporter of localization, Ernest Auburtin, reported a patient who, when a spatula was applied to the anterior part of the brain, lost all speech but not consciousness. While an intriguing finding, it was the report by the Society's founder and secretary, a French surgeon called Pierre Paul Broca (1824–80), that created the meeting's most dramatic and historic contribution. Broca saw a patient called Leborgne, who was epileptic, suffered right hemiplegia – paralysis of one side of the body – and had not spoken for twenty years. Apart from the word 'Tan' (which became his soubriquet) and a few obscenities, he uttered no other words. Broca invited Auburtin to examine Leborgne. Six days later, the patient died, and what was revealed at *post mortem* has had more impact on neuropsychology than probably any other report.

Presenting Leborgne's brain at the society the next day and the findings of his examination four months later, Broca identified damage to the second and third left frontal convolution: an egg-shaped cavity filled with fluid had occupied the brain's left side, as

Figure 1.4

A photograph of Tan's brain, with the egg-shaped cavity exposed (from *Behavioral Neurology and Neuropsychology*, T. E. Feinberg and M. J. Farah, 1997, © The McGraw-Hill Companies, Inc.)

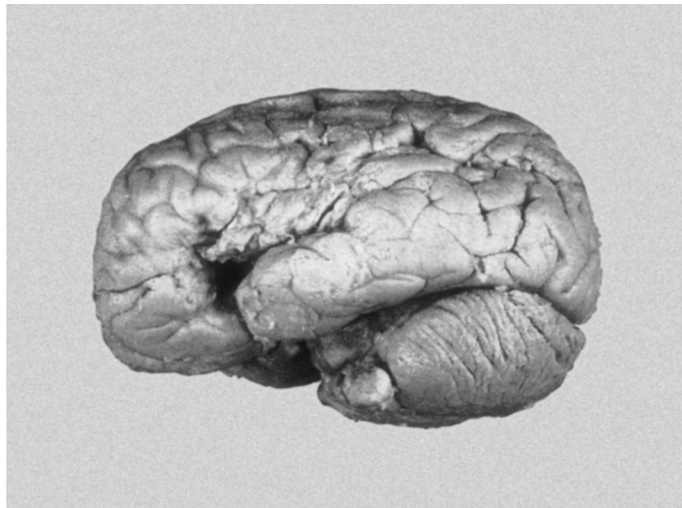

Figure 1.4 shows. Leborgne's speech production deficit became known as Broca's aphasia, and its localization in one hemisphere of the brain indicated that the brain did not behave as equipotentially as some had argued. The region responsible for speech production became known as Broca's area.

Broca later reported the case of an 84-year-old labourer with a similar brain injury and similar speech production problems; this was followed by reports of eight other cases in 1863. History works in unusual ways, however, and it is fair to say that Broca's observations were not original, although striking and enormously informative and influential. In fact, Hippocrates had associated brain damage with aphasia and noted that damage to one side of the brain (unilateral damage) resulted in paralysis of the opposite side of the body. More contemporaneously, Jean Baptiste Bouillard (1796–1881) had already reported a series of cases showing speech loss following frontal lobe lesions. He also distinguished between speech and non-speech movements and argued that since writing, drawing and painting are performed by the right hand, then the left hemisphere controls these functions (a precursor to cerebral dominance). Similarly, Marc Dax, in the 1830s, had demonstrated an association between left hemisphere injury and right hemiplegia and aphasia. He had studied over forty patients and had handwritten a paper in 1836 based on these patients' symptoms. He never published the work.

Discoveries of the nineteenth century: Wernicke and speech comprehension

The other singularly important discovery of the period was made by the German neurologist Carl Wernicke (1848–1904). He had also reported an aphasic deficit, but this time patients were unable to comprehend speech (a condition described as sensory aphasia but now known as Wernicke's aphasia, among other terms). This type of aphasia was associated with left hemisphere damage in a location below that of Broca's area (specifically, the first temporal gyrus). Patients would choose inappropriate words to use in conversation, were poor at naming objects and were impaired at writing. Importantly, Wernicke argued that not only were specific regions responsible for specific functions but that connections between regions were also responsible for function. He argued that while Broca's area was the region of the brain responsible for the motor representation of speech, Wernicke's area (as the region is now known) was the region responsible for storing 'sound images': the phonological representation of speech.

Wernicke also described other types of aphasia: global aphasia was an all-encompassing deficit in speech production and comprehension arising from damage to the anterior and posterior parts of the frontal lobe; conduction aphasia, he reasoned, would result when the connection between Broca's and Wernicke's areas was severed. The symptoms of the disconnection would comprise preserved comprehension with impaired speech output. Chapter 8 describes these disorders in more detail.

One dog, two scientists, and a German dressing table: the beginnings of modern neuropsychology

Much of the clinical evidence in the 15th century strongly suggested that localization of some functions, especially language-related functions, was probable. The year 1870 saw perhaps the clearest evidence of cerebral localization of function and presaged the dawning

of the modern science of cerebral localization and neuropsychology. Gustav Theodore Fritsch and Eduard Hitzig, two young German physicians, discovered that not only was the neocortex excitable by electrical stimulation but that it was selectively excitable (Fritsch and Hitzig 1870). Using Frau Hitzig's dressing table on which to operate (there was no suitable laboratory available), they found that selective stimulation of restricted portions of the anterior part of the brain in dogs elicited movement of particular body parts. It was another four years before a living human's brain was electrically stimulated.

However, Friedrich Goltz argued that if these areas were important, then their removal would abolish the behaviour that they mediate. In fact, when Fritsch and Hitzig decorticated their dogs, i.e. removed the outer part of the brain, the cortex, functions were not abolished but reduced. This suggested to John Hughlings-Jackson, a British neurologist, that the nervous system consisted of a series of layers organized in a functional hierarchy, with higher-level layers (the cerebral cortex) controlling more complex aspects of behaviour and lower structures (spinal cord, medulla and pons) allowing lower-level function. Hughlings-Jackson's work in the field of focal epilepsy (seizures occurring in one part of the body) also localized sensory and motor functions to particular brain regions.

Mapping brain function: Brodmann and others

With this accumulating evidence, moves to map functions of the brain became widespread. A number of these maps sought to provide a taxonomy of the brain and included projection maps that trace sensory/motor axons to the brain from their respective systems and functional maps that are constructed from information provided from the observation of the effect of brain electrical stimulation on behaviour, recording the brain's electrical activity during some form of behaviour and associating damage to the brain with subsequent behavioural impairment. One well-known functional map is based on Wilder Penfield's studies of brain electrical stimulation during surgery (see below) and outlines the motor and somatosensory regions of the brain. One of the more widely used maps is Korbinian Brodmann's cytoarchitectonic map (Brodmann 1909), seen in Figure 1.5 and Plate 1.1.

Cytoarchitectonic maps are complicated atlases constructed according to the types of cell and the density of cells that exist in specific regions of the brain. Brodmann's map assigns numbers to various areas of the brain that are distinguished by their cellular arrangement, and there is often a high correlation between Brodmann's areas and their underlying function. Area 44, for example, corresponds to Broca's area. There are regions responsible for vision and motor function that have specific, distinguishable cellular arrangements. Brodmann's map is widely used as a guide to the brain's regions (and is the one referred to in this book), and a region is usually prefaced by BA (e.g. BA 44, meaning Brodmann's area 44). Other maps developed at the turn of the twentieth century highlighted different cytoarchitectures. Oskar and Cecile Vogt's (1903) map, for example, proposed over 200 discrete regions; Brodmann's proposed fifty-two.

From the nineteenth to the twenty-first century

Towards the tail-end of the nineteenth century, neuropsychology had found its modern beginning. Scientists such as Ribot (who donated a famous law to neuropsychology, as you will see in Chapter 13) reported a distinction between amnesia (memory loss) for events occurring before injury and events occurring after (retrograde and anterograde amnesia). He

Figure 1.5

Brodmann's cytoarchitectonic maps. (a) shows a lateral view; (b) shows a cross-section through the brain (based on Brodmann 1909)

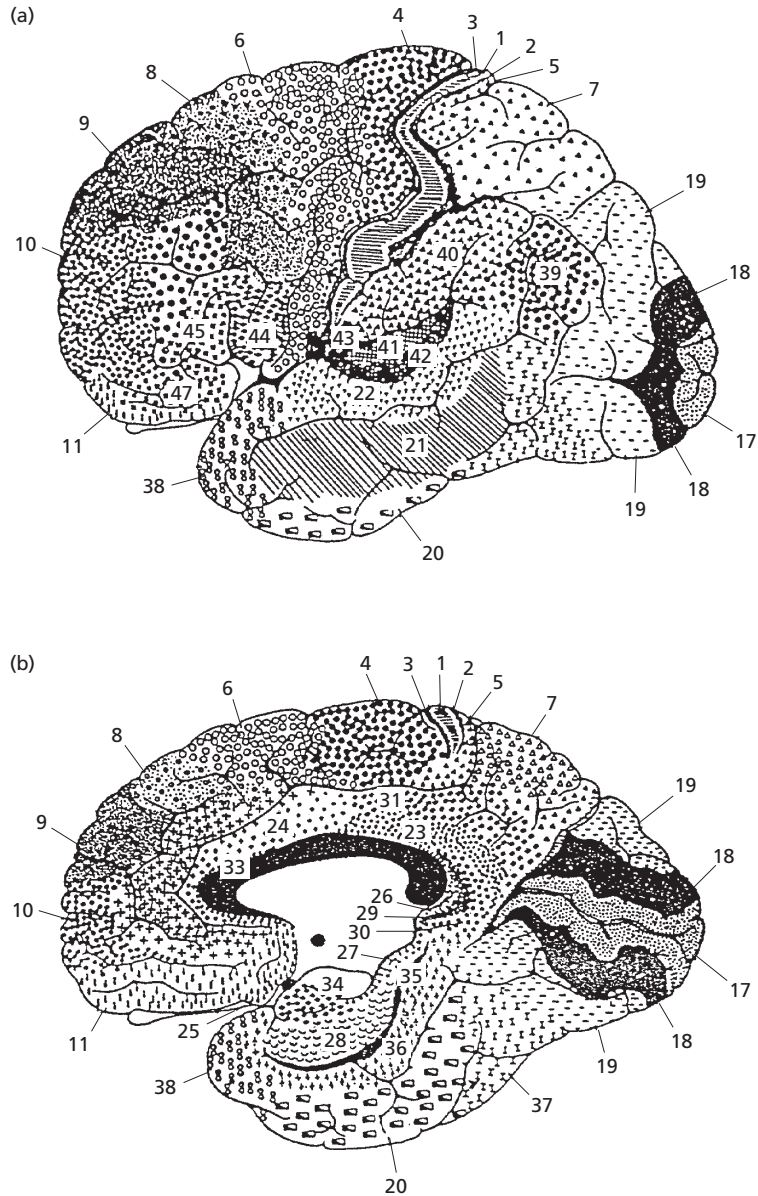

was one of the first scientists to show that people could still learn new material despite being amnesic. In 1881, Hermann Munk discovered that ablating (destroying) the occipital lobes (the regions at the back of the brain) impaired dogs' ability to recognize objects but would leave their ability to navigate the environment intact. The human analogue was later reported by Lissauer, who is credited with making the distinction between two types of visual object recognition deficit (apperceptive and associative agnosia, as you will see in Chapter 6).

However, the twentieth century brought new discoveries and techniques that rapidly advanced the science of neuropsychology. The development of the electroencephalogram

(originally recorded in the nineteenth century) and, more recently, neuroimaging techniques has provided scientists with an enviable battery of tools to study brain function and to test models of function derived from single-case studies of brain injury, which, even until the 1950s and 1960s, were the meat and drink of neuropsychology. The 1960s and 1970s, however, saw a shift towards studying groups of individuals with brain injuries and comparing their responses qualitatively against those of other patient groups and controls.

The tools of human neuropsychology: measuring brain function and structure

A large number of disciplines can, and does, contribute to the understanding of human brain function at many levels, from the molecular and biochemical level to the more gross neuronal level exemplified by the recording of the brain's electrical activity. The techniques used to examine brain/behaviour relationships reflect the multidisciplinary approach to brain function. Psychologists, psychiatrists, radiologists, pharmacologists, physiologists, biochemists and other scientists employ their own different but frequently overlapping techniques in the pursuit of this understanding.

Some of the commonest techniques used by neuropsychologists are tests of cognitive ability. These are tests that are thought to tap various cognitive functions, such as verbal ability, visuospatial awareness and memory and that might also be sensitive to brain injury. Thus, if an individual performs poorly on a test that is normally performed poorly by individuals with damage to a particular brain region and the participant performs within the same range as those with the brain injury, then the neuropsychologist might recommend some form of neurological or radiological examination (such as CT/MRI scan – see the section below) to determine whether any trauma or lesion has occurred. Often, however, the procedure works the other way around. An individual may have sustained some form of brain injury via a trauma such as accident or disease, but the neuropsychologist wishes to know whether this injury has produced deficits in cognitive ability. This form of testing, called neuropsychological assessment, is revisited in Chapter 14.

Techniques used in neuropsychological investigations are often employed on the basis of the type of topic examined, the theoretical framework guiding the method and an expectation of what one wishes to find. For example, there are techniques such as autoradiography, the Wada test or, more obviously, the split-brain operation that one would not use with normal, healthy controls for ethical, practical and theoretical reasons. However, methods such as modern brain imaging or the measurement of brain electrical activity can be used with both control and patient groups. Each approach has advantages and disadvantages.

The single-case study: in-depth exploration of brain injury and disrupted function

Given its entrenched role in the history of neuropsychology and the number of single cases that have influenced our thinking about human psychology, the single-case study approach is, perhaps surprisingly, also the discipline's most controversial. Brain lesions or

brain damage provide an invaluable, if unfortunate, source of information regarding the relationship between brain and behaviour. Although not strictly a tool – neuroscientists do not deliberately go about damaging their patients' brains for the purposes of research – lesioning or surgery does provide information concerning human brain function that is unique and that may complement non-invasive imaging techniques used with participants who are free of brain damage. In fact, as you read the many papers and books available on neuropsychology, you will find that much of the information about brain function is derived from studies of brain-damaged individuals, often in the form of case studies.

Single-case studies investigate the behaviour of one individual intensively over a long period of time. For example, patient HJA was a businessman who had suffered a stroke and had consequently sustained damage to specific regions of his brain. Following his injury, HJA's behaviour was perceptually unusual. Although his ability to tell lines of different length apart and to tell whether lines were in the same or different positions was good, he had difficulty in recognizing objects: he would spend up to six hours making painstaking drawings but would be unable to name what he had drawn (Humphreys and Riddoch 1987a, b). This is a form of agnosia, a specific deficit in the ability to perceive objects. Single-case studies of patients like HJA in this way allow the exploration of the behavioural consequences of unusual events or actions that the patient has suffered and the drawing of inferences about the principles that may underlie cognitive function, such as visual object perception. Another example of how the single-case study approach has been applied can be seen in the two boxes below.

Applying the single-case study approach: the man with the shattered world – the case of Lieut. Zasetzky

Together with those of 'Tan', HM and Phineas Gage (case studies described throughout this book), the account of one young Russian soldier's brain damage bequeathed to neuropsychology one of its most memorable case studies. Zasetzky ('Z') was a third-year mechanics student when he joined the army at the outbreak of the Soviet–German war. During one conflagration in Smolensk, an explosion damaged his left parietal lobe. The consequences of the injury were dramatic.

His cognition seemed fractionated or, in the word of the Russian neurologist A.R. Luria, who studied Z and wrote an account of the soldier's injury, 'shattered'. According to Luria, 'the bullet fragment that entered his brain had so devastated his world that he no longer had any sense of space, could not judge relationships between things, and perceived the world as broken into thousands of separate parts'.

Z's deficits were wide-ranging and involved language, semantic knowledge, reading, memory and visuospatial function (a judicious selection of quotes from Luria's book illustrating the deficits are presented in Kaczmarek *et al.*'s 2002 review of Z). Z painstakingly kept a daily diary over many years in which he would recount his difficulties. He would take a day to write only half a page and would search for each and every word he used. He started his diary before the war and continued it for twenty-five years. In this time, he managed to write 3,000 pages. To put this output into context, the book you are reading now comprises over 550 printed pages and was written in less than six months.

In addition to the word-finding difficulties he presented when writing, Z also showed language anomalies when speaking and in making judgements about the semantic content of sentences. When asked when he had been wounded, he replied: 'Well, you

see ... it's, it's ... a long time already ... must be two, three ... what's the word?' When asked to understand words representing relations between objects, he was flummoxed: 'I also had troubles with expressions like: "is an elephant bigger than a fly?" ... Naturally, I know what an elephant and a fly are, which is large and which is small. But I just didn't understand the words smaller and bigger in these expressions'.

His general knowledge was also impaired: he did not understand how wood was manufactured or what it was made of; he did not know how plants grew. His reading and writing problems were even more pronounced. When reading a newspaper, Z recognized a picture of Lenin but reported that 'still, I couldn't read any of the print, not even the largest type in the word Pravda'. His reading was laborious, and he would read a word letter by letter. He had forgotten how to use a pencil: 'I'd thrust it back and forth but I just couldn't begin to write'.

His main problem appeared to be amnesia: he would forget what he ate for breakfast and dinner and could not visualize scenes and objects. This was compounded by serious visuospatial impairment: 'I've had some trouble sometimes sitting down in a chair or on a couch. I first look to see where the chair is, but when I try to sit down I suddenly make a grab for the chair since I'm afraid I'll land on the floor'.

Luria identified Z's deficits as anomic aphasia (hence, the word-finding difficulties), impairments in understanding logical and/or grammatical relations, an unspecified form of dyslexia, and visuospatial impairment. These deficits are consistent with injury to regions in the middle and back of the brain called the left parietal lobe and parieto-occipital-temporal cortices.

Luria was a pioneer in many ways, not least in his enormous contribution to understanding brain injury and in generating models to explain its consequences. He also pioneered a way of presenting neuropsychological data to a lay readership. Nowadays, popular science accounts of the brain and its dysfunctions abound. Luria was one of the first brain scientists to make a deliberate attempt to publish a book on a complex, if human and fascinating, topic that would also be popular with non-scientists.

Applying the single-case study approach: patient NA and the perils of a miniature foil

This is a description of what happened one afternoon to a young man (called NA in the literature), in his own words:

I was working at my desk ... My room-mate had come in (and) he had taken one of my small fencing foils off the wall and I guess he was making like Cyrano de Bergerac behind me ... I just felt a tap on the back ... I swung around ... at the same time he was making the lunge. I took it right up the left nostril, it went up and punctured the cribiform area of my brain.

PARKIN 1997

In his review of NA's neuropsychological history, Parkin (2003) notes that NA is not alone in the type of injury he suffered (technically called a 'low-velocity intra-nasal penetrating injury'). Suicide by chopsticks had been reported – this is where chopsticks are placed

inside the nostrils and forcibly rammed into the skull and brain (Yamamoto *et al.* 1985), as had cases of a boy with a brush stuck up his nose (Rawlinson *et al.* 1988) and a man who, after an altercation in a snooker hall, left with a snooker cue lodged in his left nostril (Dusoir *et al.* 1990). However, NA's contribution to neuropsychology has been longer-lasting because of what it reveals about the process of memory.

NA's case was reported by Teuber *et al.* (1968) eight years after the event and sheds some very interesting light on the limitations of single-case studies and on the interpretation of neuroanatomical findings. People can be inconsistent or incorrect in what they recount, and NA is no exception: the foil, for example, had entered his right nostril, not his left. Teuber *et al.*'s report describes a duel as having taken place, another statement at odds with NA's recollection.

NA presented with a memory impairment called anterograde amnesia – an inability to remember information learned after the injury. He was also unable to gaze upwards (a condition called Parinaud's syndrome) and presented with out-of-body experiences (called autoscopy): on one occasion, he asked his mother why she was talking to the man in the bed instead of him. He was the man in the bed.

Although NA's initial learning was normal, he would forget within 40 minutes what he had learned. His verbal short-term memory was worse than his spatial memory (memory for locations, for example), but his recollection of events prior to the injury was normal. Detailed testing showed that his memory for events between the ages of 10 and 20 was intact but that memory for events two years prior to the accident was

Figure 1.6

A reproduction of the figure rendered by Weiskrantz to the pathway of the foil through NA's brain (from Parkin 2003)

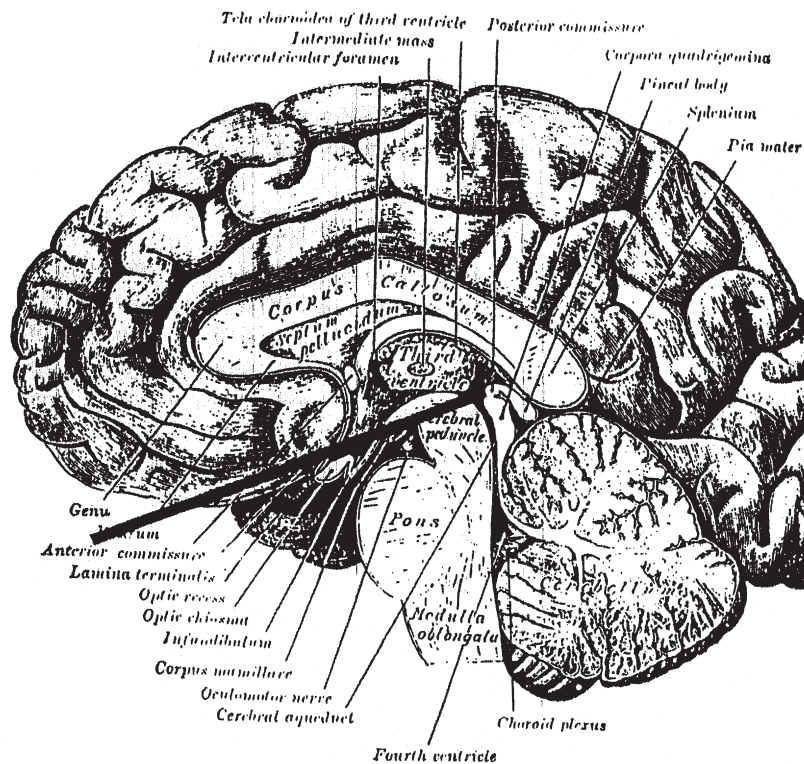

impaired (Squire and Slater 1978; Zola-Morgan *et al.* 1983). Unlike another famous memory-impaired patient, HM, NA's damage was not to the temporal cortex but to more midline structures. Based on data from what we would now consider quite crude neuroradiological methods, Squire and Moore (1979) localized the damage to the orbito-frontal cortex (in the front of the brain), the corpus callosum (the band of fibres that connects the two sides of the brain), the left ventricle, the neostriatum and the left thalamus (two structures located deep inside the brain). His damage became thus described as dorso-medial. However, Weiskrantz (1985) argued that it would not have been possible to damage the dorso-medial areas without damaging other areas too. If this was the pathway of the foil, it would have to have risen through the front of the brain, into the corpus callosum and progressed down towards the thalamus. Weiskrantz suggested that the foil should also have damaged a collection of small structures called the mamillary bodies. His prediction of the trajectory of the foil can be seen in Figure 1.6.

In fact, Zola-Morgan and Squire (1985) had attempted to simulate the foil's trajectory in a male cadaver. Two attempts passed through the orbito-frontal cortex and ended in the corpus callosum; a third ended in the anterior thalamus. None affected the mamillary bodies.

An MRI scan of NA's brain in 1989 showed, as Squire had initially reported, damage to the left thalamus, part of the dorso-medial nucleus and other subcortical pathways (Squire *et al.* 1989) but his mamillary bodies were missing. There was no damage to the cortex. The scan showed what Weiskrantz (1985) had predicted; it did not support the trajectory proposed by Squire and Moore (1979).

Commenting on this case study, Parkin (2003) issues a valuable caveat. 'The basic lesson,' he writes, 'appears to be that neuropsychologists interested in the relationship between brain structure and function are at the mercy of the neuropsychological methods they use' (p. 106).

The study also shows why a keen and critical mind is essential when reading about, and interpreting, the behavioural and neuroanatomical consequences of brain injury.

The forms of brain damage seen by clinicians can be caused by accidental head injury (such as NA's), disease, infection, virus or psychosurgery. Psychosurgery might involve the removal or lesioning of a particular part of the cortex to alleviate certain behavioural symptoms. To treat the symptoms of intractable epilepsy, for example, the structures connecting the two hemispheres of the brain may be severed almost completely, thus preventing the passage of the epileptic seizure from one hemisphere to another (this is called a commissurotomy). However, the severance of these connections appears to result in a lack of communication between the two hemispheres, giving rise to certain peculiarities and irregularities in a patient's behaviour after surgery. A common consequence of commissurotomy is that information processed by one hemisphere cannot be processed by the other. The surgical procedure is popularly known as 'split-brain' surgery and is described in Chapter 4.

Lesioning the human brain produces several functional consequences. It can produce a loss of function (normally, the larger the lesion, the greater the loss of function), a release of function (a new behaviour appears or an old behaviour increases) or functional disorganization (not being able to produce behaviour that requires sequential movement, for example). However, it is important when interpreting brain lesion studies to take into account three important points. First, it is advisable to have a description of the patient's

behaviour before the trauma or to administer a test that can determine this. What is required here is a pre-morbid (meaning, before the damage) index of the patient's cognitive function. This is important, because the test norms may not apply to the individual. For example, imagine a highly intelligent individual whose pre-morbid IQ was 150 but this decreases to 110 after a head injury. Given that the population average is 100, this person is still performing effectively in comparison with the norm, but his own function has markedly declined.

Second, meticulous identification and description of the locus of the damage is important. As human participants' brain damage is often accidental or the result of factors beyond the researcher's control, several brain areas may be damaged in unison. Localizing a behaviour to a given region or structure may therefore be difficult, as other structures may be involved. Furthermore, the serendipitous nature of this research suggests that only a few individuals will present the form of brain damage being studied. Many neuropsychological studies are based on single cases. This leads to the third important point and explains some of the controversy that surrounds the issue. This is taken up in the discussion point.

Discussion point: what is the point of the single-case study?

In a review of the pros and cons (but mainly pros) of what they call the single participant research design (SPRD), Morgan and Morgan (2001) argue that SPRD can provide a richer source of data than the normal hypothesis-testing strategy approach adopted in psychology (where you derive a hypothesis based on a theory and test it in groups of individuals).

Morgan and Morgan acknowledge that the SPRD approach is not widely regarded and list a number of reasons for this: (1) there are perceived problems in interpreting single participants' data; and (2) the data collection format is not one that most psychologists have been trained to use. However, the authors argue that the design has advantages over typical group designs. One is that by continuously studying a participant over an extended period, we can be sure that the sample of behaviour that is measured is representative of the participant's typical behaviour. This also allows for easy replication, although there are clearly some studies employing an independent variable that cannot be properly replicated – a learning intervention, for example, cannot easily be unlearned. The SPRD approach may also allow you to see natural variability in the participant's behaviour – marked changes in behaviour that are not attributable to experimental manipulation.

However, critics of the approach argue that SPRD has little external validity – the obvious conclusion that the behaviour of one individual cannot be generalized to others. It is perceived as being anecdotal and therefore of little scientific merit.

It is true that interpretation of the findings from studies involving single cases must be done circumspectly. Because findings are presented from a very small number of individuals, it is worth bearing in mind that the changes in behaviour observed may not be common to all individuals who present with the same form of brain damage. What may be needed is the assessment of several investigations involving single cases and the extraction of the common features that they share. An alternative consideration is to conduct a group study, where individuals with known damage to certain brain regions are tested as an homogeneous group. However, this may be difficult given the variation in the locus of damage.

McCarthy (2001) has argued that 'case-based research has possibly been at its most successful in analyzing the fractionation of cognitive skills rather than localizing neural substrates'. The view crystallizes two views of neuropsychology that are often trenchantly held: one argues that studies of brain injury do no more than constrain theories of cognition. That is, they help us to understand how memory works or how we comprehend speech or read because patients present with highly unusual symptoms that show what happens when a normally functioning system is impaired. Whether these studies tell us where such functions occur is irrelevant. The opposing camp argues that such studies are vitally important in allowing us to localize cognitive ability and that by understanding the neural substrates of behaviour we are in a better position to explain how we remember, think, make decisions, feel happy and so on.

However, Kosslyn and Van Kleeck (1990) have argued bluntly that there exists 'no simple or direct relation between the nature of the behavioural dysfunction and the nature of the underlying (normal) complaint' (p. 392). In short, they suggest, you cannot interpret a superficial physical feature of the brain (the injury) as having any causal relationship with the impaired function the patient presents. Why? One important reason is that the site of injury may not be directly necessary for the disrupted function. It is possible, and likely, that an adjacent brain region connected to the damaged area is the more important region, but because the connections between the damaged region and the intact region have been severed the intact region cannot function normally.

It has also been argued that dissociations in function do not suggest that two separate mechanisms underlie the dissociated functions. A dissociation arises if patient X is impaired on task 1 but performs normally on task 2 (Ellis and Young 1996). However, if patient X is impaired on task 1 but can complete task 2, whereas patient Y performs normally on task 1 but poorly on task 2, this is called a double dissociation. Some neuropsychologists have argued that such dissociations are very rarely operationally defined, i.e. described in detail (Crawford *et al.* 2003). This procedural problem is augmented by the problem of interpretation. For example, it could be argued that a dissociation does not show genuinely different mechanisms or functional subsystems but simply a difference in how two tasks are processed. Differences in performance, for example, might be due to task difficulty rather than a specific impairment in a circumscribed function.

In a further sop to the integrity of the single-case study approach, Kosslyn and Intrilligator (1992) provide several criticisms of what they call strong cognitive neuropsychology. Weak cognitive neuropsychology uses data from brain injury to constrain theories of cognition. Understanding how a system normally functions can be assisted by observing how it fails, this type suggests. So far so good. However, the strong type has the goal of inferring the structure of normal cognition from studies of brain injury. This is the type that Kosslyn and Intrilligator have a problem with. Their criticism rests on the argument that the brain is a non-linear and dynamic system, not a collection of isolated parts. This criticism is identical to that which argues that the area contributing to the disrupted function may not be that which is damaged but the region that has had its connections to the damaged area severed.

They also take issue with the fractionation hypothesis – the idea that brain damage results in selective impairment of a specific function. They argue that brain injury very rarely affects only two discrete brain areas, and therefore it is impossible to ascribe function to the area damaged. To support their argument, they cite a finding from Caramazza and Hillis (1991) (Caramazza is a strong proponent of strong cognitive

neuropsychology). In this study, one patient could not write verbs but could utter them; a second could utter verbs but not write them. Both could read and write nouns. In short, a typical classic double dissociation, suggesting that there are two separate regions in the brain for mediating verb and noun processing and different regions mediating the writing and the speaking of verbs. Or are there?

Could the difference be due not to the way in which verbs and nouns are processed – writing and speaking – but to the way in which responses using those verbs are measured? What if response times are measured instead of error rates? It is possible that the patients took an abnormally long time to write nouns, but because only accuracy was measured, this vulnerability was not reported. If the patient had taken longer over the verbs, perhaps the performance would be comparable with that produced by the nouns. The important point, Kosslyn and Intrilligator suggest, is that the study did not take into account task difficulty. Consequently, the deficit reported is not a representational one but one reflecting different (inappropriate) processing strategies.

The debate may seem an arcane one, and it is true that it generated much more excitement and disagreement in the 1980s and early 1990s than it does today, although a recent special issue of *Cognitive Neuropsychology* (see recommended further reading) featured articles raging for and against the views summarized here.

Single-case studies

Advantages

- Valuable because human brain lesions cannot be performed experimentally
- Brain damage may highlight role of damaged region in function
- Allows in-depth study over long periods of time
- Can be used to constrain theories of cognition in a way not possible in experimental studies of healthy individuals

Disadvantages

- Invasive
- Subject to individual differences
- Locus of damage can be variable and may not always be described accurately
- Previous level of functioning may be unknown
- Other damaged brain regions may be producing deficits
- There may be confounding factors such as medication use

Connectionism/neural networks/computational modelling

An approach to understanding brain injury and behaviour that gained momentum in the 1980s and 1990s but has stabilized in recent years is connectionism or computational modelling, which attempts to simulate or model connections between units of neurons using computer algorithms. By modifying the activity of a neuronal network – such as creating an artificial, computer-generated lesion – modellers hope to predict the consequences of the damage.

The approach derives from Rumelhart, McClelland and the Parallel Distributed Processing Group's (1986) notion that cognition occurs through parallel distributed processing. That is, our ability to process information does not occur serially, one stage at a time, but in parallel. This improves the speed and efficiency of our information processing. In brain terms, multilayered networks of neurons allow parallel processing of information. It is assumed that the type of event prompted by information processing – understanding the word 'table', for example – is reflected by a pattern of activation in this system rather than by a single discrete point of activation.

When such an artificial system is stimulated, the whole network is activated; however, repeated activation will lead to the connections between parts of the network being strengthened. These parts are called units (rather than neurons). Some networks are specialized for categorizing or sorting input (feed-forward networks), others for storing information (recurrent networks). An example of a function modelled by the former would be grapheme–phoneme correspondence conversion during reading (translating written language into sounds); an example of the latter would be the storage of memory.

Computational modelling has been used to simulate aphasic patients' language problems, speech errors and speech production (Dell 2004; Dell and Sullivan 2004). It has also been applied to deep dyslexia (Plaut and Shallice 1993), surface dyslexia (Plaut *et al.* 1996), face recognition (Burton *et al.* 1990), fear conditioning (Armony *et al.* 1997), word recognition (Mayall and Humphreys 1996), switching cognitive strategies (O'Reilly *et al.* 2002), and memory consolidation and amnesia (Meeter and Murre 2004).

Observers have noted that it is important that models such as these take into account the location and extent of a lesion (Lambon Ralph 2004). It might be argued, for example, that it is impossible for all neurons in the brain to be activated by a stimulus, so the brain will use the most local connections. McCloskey (2004) has also noted that computational models are just that: models of theories, not theories themselves, and are therefore limited in what they do. For example, they cannot take into account all of a theory's assumptions. McCloskey cites the example of models' simulations of lexical processing: these can simulate only a minute fraction of the lexicon.

Other critics are harsher. Pinker, for example, has criticized the way in which models learn information, regarding the process as woefully ignorant (Pinker 1997; Pinker and Mehler 1988). He points out that models frequently require several thousand learning trials, unlike the human brain. This is one of the most serious limitations of computer modelling and simulation: the very nature of their existence – simulation – means that they are far removed from how the actual brain is thought to function.

Computational modelling

Advantages

- A non-invasive method of simulating brain function
- Does not require any 'physical' participants
- Allows the 'lesioning' of a 'neural' system

Disadvantages

- Process is artificial and behaviour simulated not reflective of the way in which people behave
- Rudimentary

Electroencephalography (EEG)

In 1875, Richard Caton, a British physiologist at the University of Liverpool, found that it was possible to record changes in electrical potentials arising from the brain's 'feeble currents' from the scalps of living monkeys, cats and rabbits. Over fifty years later, Hans Berger, a German psychiatrist, reported what is thought to be the first recording of brain electrical activity in humans (Berger 1929). This brain potential became known as the Berger or alpha wave. Over ten years after this discovery, which was not entirely accepted by the scientific community, Adrian and Mathews (1934) reported a study in which they were able to record electrical activity from the olfactory bulbs of hedgehogs. The currents they were recording were electroencephalograms (EEGs), sometimes known colloquially as brainwaves.

The EEG technique is now a part of the clinician's modern battery and, used selectively, can provide useful clinical information as well as information of use to research scientists. The technique is usually non-invasive to humans: the organism is not 'invaded' by any piece of mechanical equipment, because electrical activity of the brain is recorded by electrodes placed on the scalp. Electrodes may be either placed on the scalp individually according to an agreed placement system called the International Electrode Placement System, or fitted to an electrode cap, which the subject wears on the head like a swimming cap (see Figures 1.7 and 1.8).

In animals, it is possible to implant microelectrodes in specific neurons or around a neuron or groups of neurons and monitor the electrical activity from within (intracellularly) or outside (extracellularly) these neurons as the animal behaves. For ethical reasons, this procedure is not normally used in humans (although a version of the technique where the charge is reversed and neurons are excited is used in therapeutic contexts for the treatment of motor disorders such as Parkinson's disease). With human participants, macroelectrodes, which measure activity from millions of neurons, are placed on the scalp. The number of electrodes used is determined by the researcher's hypothesis-testing strategy and can range from two or three to over 130.

The EEG technique is widely used in healthy and clinical groups to indicate the brain's level of electrical activity while it is processing a particular task or responding to a particular stimulus. The EEG signal is generated by the post-synaptic dendrites of millions of brain cells called pyramidal cells. The signal itself is very small (not more than 100

Figure 1.7

A selection of electrode sites from the 10–20 International Electrode Placement System

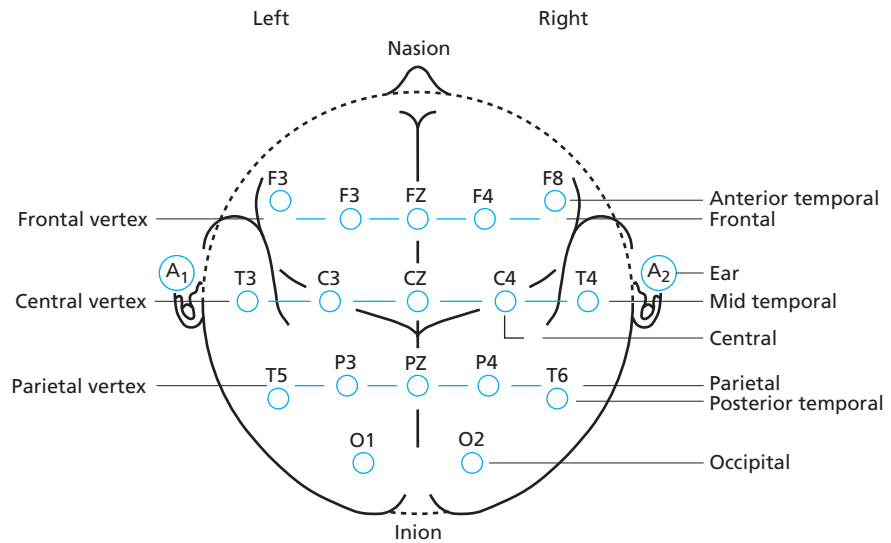

Figure 1.8

A typical experimental setting for recording of EEG (A. J. Photo/Hop American/ Science Photo Library)



microvolts, μV) and therefore must be amplified many times before it is fed through to a line polygraph (or monitor, if the system is sophisticated enough) and seen as the EEG wave. The signal is the difference in potentials between two electrodes, where one electrode is a reference, i.e. it is placed at a site where little electrical activity is thought to occur (the earlobe, or an electrically inactive part of the body). There continues to be debate over which parts of the body are the best sites for non-active electrodes.

Figure 1.9

The conversion of the raw EEG from three electrodes (F3, C3 and P3) into the four classical EEG frequencies: from slowest to fastest (delta, theta, alpha and beta)

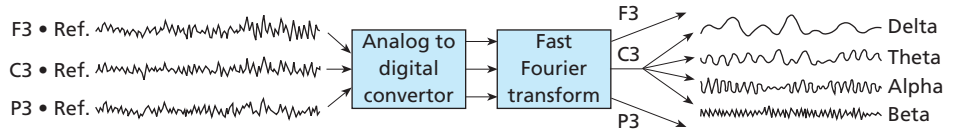

The EEG is divided into four classical wavebands, which describe how often a wave appears each second (its frequency, in hertz, Hz). From largest to smallest, these are delta (1–4 Hz, i.e. the wave appears 1–4 times a second), theta (5–7 Hz), alpha (8–12 Hz) and beta (13–22 Hz), as seen in Figure 1.9. Alpha is thought to be the human adult’s resting EEG, normally seen under quiet, unstressful conditions (Niedermeyer 1987). When there is a shift in frequency due to some cognitive activity or external stimulation, the neurons are thought to be desynchronized. This is sometimes called alpha desynchronization, because alpha activity is replaced by the much faster beta activity.

The EEG is a measure of gross brain activity and function (activity from millions of cells is recorded by one electrode), although it does provide useful information about fluctuations in brain electrical activity and their relationship with function. In an experimental setting, a ‘baseline’ EEG is recorded by having the participant sitting comfortably with eyes closed for two or more minutes or having them fix on a spot ahead of them in the distance. This can then be used to compare with changes that might occur when the participant is performing a particular task, such as mental rotation or mental arithmetic. It is difficult to localize a function using this technique, however, since the generating source may be at some distance from the recording electrode. Often, there are other sources of evidence that guide the site of the electrodes chosen for recording. There is also the additional problem of ‘smearing’, i.e. the attenuation or impedance of the signal from the generating site to the recording site by the matter lying between these two areas.

An example of how EEG has been used to study one example of behaviour – smelling – is described in the box.

Applying EEG: chocolate on the brain

No-one quite knows what EEG frequencies mean or represent, but psychologists have drawn conclusions about possible functions based on correlations between the appearance of certain frequencies and specific behaviour. In an experiment using the real and synthetic odours of food as stimuli, Martin (1998) found that the odour of chocolate was consistently associated with a reduction in theta activity when compared with other food odours, including coffee, lemon, baked beans, rotting pork, cumin and almond. Theta appears to increase during states of concentration and hard mental work. Experiments have shown that when people are given a series of words to learn, theta is greatest when recall is accurate (Klimesch *et al.* 1997). Theta may also be related to attention such that greater attention to a stimulus is associated with greater increases in theta activity. Chocolate was rated as one of the more relaxing and pleasant of the odours, and perhaps its effect is to ‘relax’ the brain. If the theta hypothesis is correct, the relaxed state induced by smelling chocolate results in reduced concentration, which produces the reduction in theta activity.

EEG

Advantages

- Non-invasive
- Excellent temporal resolution
- Relatively easy and cheap to operate
- Can be used with healthy and clinical human participants
- Can be used to record brain electrical activity in real time
- Can be used to measure the brain's response to a number of psychological variables

Disadvantages

- Ability to localize function is weak – generating source may be at some distance from the recording source
- Activity is recorded from millions of groups of neurons
- Signal may be attenuated and smeared
- Brain activity may fluctuate unpredictably and 'chaotically'
- Susceptible to movement artifact
- Unclear what EEG changes signify

Event-related potentials (ERPs)

Event-related potentials (ERPs) are large, slow brainwaves that appear as a result of sensory or cognitive stimulation. They are also called evoked potentials (EPs) or averaged evoked potential waves (AEPs). The ERP recording technique, like the EEG, is an electrophysiological one. That is, it is a measure of the brain's electrical activity. Under normal recording conditions, the EEG can be very 'messy' and 'busy': there is a lot of background noise. The ERP is useful in that it allows this background noise to be diminished through the repeated presentation of stimuli. This enhances what is called the signal-to-noise ratio (Picton *et al.* 2000).

For example, in a typical auditory evoked potential experiment, a series of stimuli (usually, a tone) are presented to the participant as EEG activity is being recorded from electrodes placed on the scalp. The brain's response to each stimulus is thus summed and averaged. Normally, a tone would not in itself have much effect in altering the EEG; however, repeated presentation of a stimulus makes the effect on the EEG very clear. What appears above the noise is a large, clear, slow wave. These waves are given names such as N100, P200, N200 and P300, depending on polarity and time of onset, i.e. the direction of their peaks (N = a negative peak, usually meaning downward-pointing; P = a positive peak, upward-pointing) and their time of appearance (in milliseconds, ms) following stimulus presentation. The polarity refers to the wave's amplitude; the time of onset refers to latency.

In addition to these 'standard' types of EP wave, there are others such as the N400. This was the first ERP to be linked with language processing and is elicited when participants read sentences in which the last word is semantically surprising or inappropriate,

although linguistically legal (Kutas and Hillyard 1980). The amplitude of the N400 is associated with processing difficulty such that the more difficult the task, the greater the amplitude of the N400 (Kutas and Van Petten 1994). The N400 declines when congruous sentences are presented – the last word is predictable – but not when incongruous ones are presented (Van Petten and Kutas, 1990).

Some researchers have suggested that the N400 reflects a difficulty in integrating words into a sentence (Kutas *et al.* 2000): the greater the difficulty, the larger the N400. The box below shows how the ERP technique has been used to investigate the likelihood of this in a study of the comprehension of a specific type of sentence – jokes.

Applying ERP: what's the joke?

The N400 wave of the ERP, as the section on ERPs shows, is associated with the processing of meaningful linguistic stimuli, especially sentences. The process of understanding these stimuli should be reflected in a higher-amplitude N400 wave if stimuli are challenging or difficult, and this is what the literature reports.

Curiously, this wave can appear in surprising contexts. One study found that the processing of the key word in a joke was associated with a larger N400 than was the same sentence with this key word replaced by a more predictable one (Coulson and Kutas 2001). There is some evidence that joke comprehension relies on the right more than the left hemisphere. This finding has emerged from studies of brain injury (e.g. Bihrlé *et al.* 1986; Shammi and Stuss 1999), as well as one neuroimaging study of healthy participants (Goel and Dolan 2001). Would the N400 therefore appear differently in the left and right hemispheres?

To answer this question, Coulson and Williams (2005) recorded ERPs while sixteen right-handed English speakers read a sentence where the last word was an unexpected (i.e. 'punchline') word leading to a joke, or an expected word. For example, in the joke condition, the sentence would read:

A man who has lost ninety percent of his brain is called a widower.

In the non-joke condition:

A man who has lost ninety percent of his brain is called a zombie.

Sentences were presented to either the left visual field (projecting to the right hemisphere) or the right visual field (projecting to the left hemisphere).

The study found that the amplitude of the N400 was significantly higher in the left hemisphere when participants read the joke than the non-joke. When the sentences were presented to the left visual field (the right hemisphere), amplitudes were about equal, as Figure 1.10 shows.

The result suggests that the right hemisphere is fairly adept at reading both types of sentence, possibly because it is especially adept at comprehending the semantic factors involved in jokes. However, the left hemisphere seemed to find the joke's punchline word difficult to integrate into the sentence, hence the greater effort expended (and the larger N400). Coulson (2000) has referred to the process involved in

understanding the format of the joke used in this ERP study as ‘frame-shifting’, because the sentence leads the participant to think in a certain way but this way of thinking has to change radically with the revelation of the last word. Perhaps this is a function of the right hemisphere.

Figure 1.10

Differences in the amplitude and latency of the N400 when people listened to sentences where the last word made the statement into a joke (from Coulson and Williams 2005)

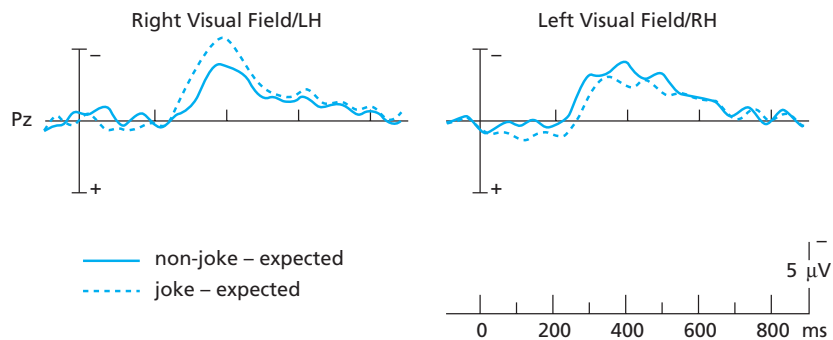

Early ERPs such as the N100 and P200 are thought to represent stimulus processing, the brain’s initial response to sensory stimulation. These types of sensory stimulus are thought to elicit exogenous ERPs: evoked potentials (EPs) that do not rely on ‘cognitive’ processing but that are the result of either the sensation or the perception of a sensory stimulus. An example of the types of change in electrical potentials is seen in Figure 1.11. The later waves, specifically the P300, are thought to reflect more endogenous components of processing such as decision making, context updating, cognitive processing or response to stimulus uncertainty. Because of this assumed function of the P300, researchers have paid considerable attention to it.

Figure 1.11

Example of the N100 (the negative peak) and P200 (the positive peak) elicited by an auditory stimulus. The two waves represent EPs recorded while participants listened to a tone during exposure to two different odours

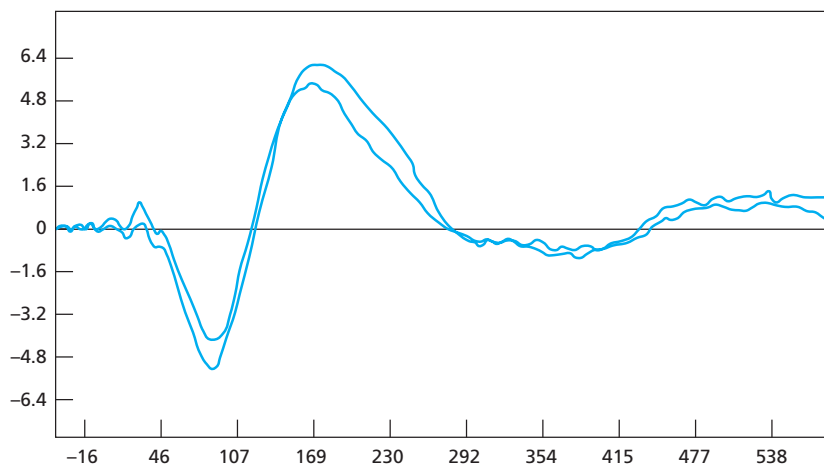

While many demand characteristics regulating the appearance of the P300 are known, the neural mechanisms underlying it are still something of a mystery. The P300 was originally reported by Sam Sutton and his colleagues in 1965 (Sutton *et al.* 1965). They found that if participants were required to keep track of the number of stimuli in a series presented to them and the occasional stimulus did not appear, a late-going positive wave (the P300) was elicited. In fact, the P300 is usually elicited when unusual, infrequent or unexpected stimuli appear in a series of frequent or expected stimuli (see Donchin and Coles (1988) and Polich and Kok (1995) for good reviews of the P300). One of the most common ERP tasks that elicits the P300 is called the ‘auditory oddball’. Here, participants count the number of low tones in a series of high and low tones where there are always fewer low tones (rare stimuli) than high (frequent stimuli). Presentation of the same type of tone does not produce the P300; the appearance of a different type of tone does. This can be seen in Figure 1.12. Because of this change in brain activity to rare stimuli, it has been argued that the P300 reflects either the organism’s decision-making process, i.e. deciding whether the tone is different, or context updating, i.e. familiarization with new elements in the environment to accommodate the appearance of an unexpected stimulus in that environment.

The ERP technique has been used to study a number of cognitive processes, including memory, language and attention. It has also been used to evaluate the cognitive deterioration found in neuropsychiatric disorders (such as schizophrenia, anxiety and depression) and degenerative disorders (Alzheimer’s disease, alcoholism, Korsakoff’s disease, multi-infarct dementia, auto-immune deficiency syndrome). If the P300 is a good index of successful processing, the argument goes, it may provide a useful indication of the onset of the types of cognitive deficit seen in these disorders (Polich and Kok 1995). An example of the type of clinical evoked potential is seen in Figure 1.13.

Figure 1.12

Two examples of EPs elicited by auditory stimuli. The waves on the left represent potentials evoked by a series of same-tone stimuli (e.g. a low tone); the waves on the right represent potentials evoked by a series of two different tones (e.g. a high and a low tone). In the latter condition, the P300 is evoked by the ‘different-sounding’ tone (from John Polich, Cognitive Electrophysiology Laboratory, The Scripps Research Institute)

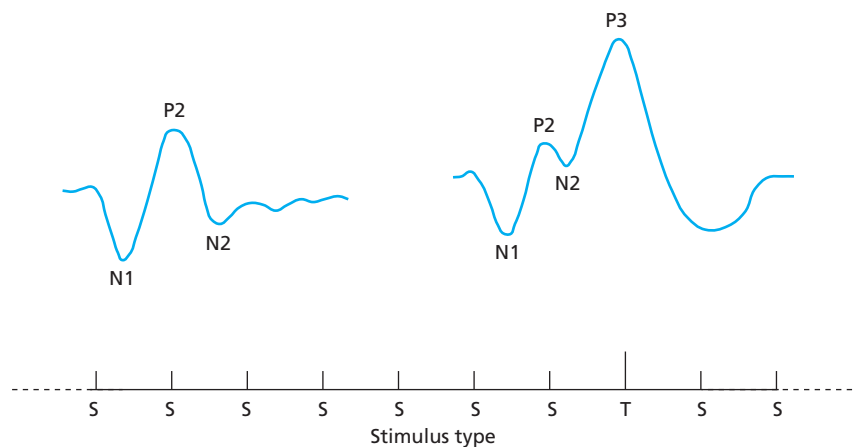
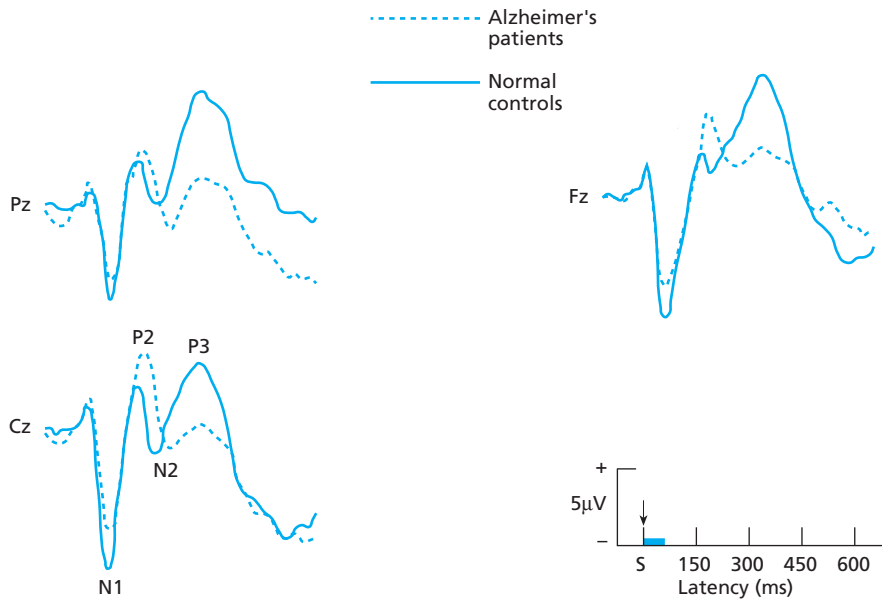

Figure 1.13

A comparison between the ERPs from patients with Alzheimer's disease and those from control subjects. A markedly reduced P300 is seen for the demented patients at each electrode site (from John Polich, Cognitive Electrophysiology Laboratory, The Scripps Research Institute)



Event-related potentials

Advantages

- Can be used in healthy and clinical participants
- Useful index of sensory function
- Possible measure of cognitive decline and normal cognitive function
- Non-invasive
- High temporal resolution (one millisecond)
- Relatively easy to use and measure

Disadvantages

- Significance of some waves unknown
- Mechanism underlying ERP poorly understood
- Spatial resolution relatively poor

Magnetoencephalography (MEG)

A more recently developed electrophysiological technique is magnetoencephalography. Neurons generate magnetic as well as electrical currents, and these magnetic fields can be measured from the surface of the head via a machine called a superconducting quantum interference device (SQUID), which is immersed in liquid helium. The machine detects the activity of magnetic fields from a large number of neurons, because the magnetic fields generated by single neurons are very weak. The subsequent recording is called the magnetoencephalograph or MEG. Unlike the EEG, MEG can be used to localize sources of activity fairly well, and these sources can be plotted on a three-dimensional image of the participant's head. MEG has been used to study various functions, from language to olfaction. Plate 1.2 illustrates the output of MEG. An example of the way in which it has been recently used is described in the box.

Applying MEG: sentence comprehension in poor readers

One of the most widely studied functions in MEG is language. There are two reasons for this: language is the most widely studied neuropsychological function and MEG lends itself well to testing hypotheses about the spatial and temporal aspects of language processing. It can also shed some light on how aspects of brain activation vary with a person's increasing and decreasing language proficiency. People with an inability to read well, for example, have difficulty with specific aspects of language, especially phonological aspects (its sound). Dyslexic individuals will have difficulty distinguishing between the syllables /ba/ and /da/, indicating that their phonological processing is impaired (phonological processing is discussed in more detail in Chapter 8).

Dyslexic readers also experience problems with understanding the meaning of sentences. Normal readers who hear a sentence where the last word is unexpected (but linguistically legal) show an N400. Dyslexic readers, on the other hand, show a delay in the onset of the N400; it is also smaller when the last, unexpected word in the sentence begins with the letters of an expected word.

Helenius *et al.* (2002) asked ten dyslexic and nine good readers to listen to sentences where the last word was either inappropriate or appropriate. Half of the inappropriate words began with two or three phonemes (the smallest units of sound) shared with the expected, appropriate word. For example, 'the gambler had a streak of bad luggage' was presented when 'the gambler had a streak of bad luck' would be more expected. MEG recorded brain activation as participants listened to the sentences.

Two patterns were found in the temporal lobe, one reflecting immediate sensory perception of sound and another that was more semantically related. The first appeared 100 ms after the onset of the sentence and was abnormally large in the left hemisphere of dyslexic participants. Sentences with unexpected endings activated the superior temporal cortex (near the part responsible for processing sound – it may take around 10–15 ms for sound input to reach here). The N400 response was delayed in the dyslexic sample when the unexpected last word of the sentence began with a similar sound to the expected word. The results suggest that a person's initial access to words is based on the words' acoustic or phonological features (hence, the activation in the temporal cortex).

MEG

Advantages

- Non-invasive
- Superior to EEG in terms of localization
- Signals not distorted by conduction between skull and sensor
- Spatial resolution quite good (better than ERP)

Disadvantages

- Participant cannot move during recording
- Very expensive and requires magnetically shielded room
- Spatial resolution, i.e. the clear delineation of brain regions activated, is poor

Computerized tomography (CT)

The first modern scientific method of imaging the brain was developed in the early 1960s and 1970s by Allan M. Cormack, a South African physicist, and Godfrey Hounsfield, a British engineer who worked independently on developing the technique (Cormack 1963; Hounsfield 1973). This technique, known as X-ray computerized tomography (X-ray CT), utilized the fact that different tissues absorb differing amounts of X-ray energy. If X-rays are passed through organs and tissues at various angles, the amount of radiation not absorbed by these tissues will allow the reconstruction of the structure of these organs and tissues. Computerized tomography measures the amount of radiation not absorbed by the brain when X-rays are passed through the brain. A three-dimensional representation of the brain is produced as a result of the X-ray beam being rotated through 180 degrees at 160 equally spaced positions. This became a useful technique to neurologists, who could for the first time use such an image to detect structural anomalies in the living tissue of patients with brain trauma and lesions. Furthermore, an advantage was that the technique was relatively non-invasive and caused little discomfort to the patient. An example can be seen in Plate 1.3.

A technique that owes much to the development of CT is tissue radiography. This method is used almost exclusively in animals and measures the distribution of radioactivity in a radioactively injected organ. After an injected animal is killed, *post mortem* slices of the organ (e.g. the brain) are examined by placing them on film sensitive to radioactive materials. The developed film indicates the parts of the organ that were more or less radioactive. For example, a form of radioactively labelled glucose will give information about brain metabolism, because neurons derive energy from glucose. The principal problem with this technique for human participants is the obvious need for *in vivo* measurement of function.

The basis for the development of human autoradiography was the idea that if the structure of an organ could be delineated by passing an X-ray through it, then it may be possible to trace the appearance of a radioactively labelled material, called a radioisotope, by measuring the degree of radioactivity emitted by a particular living tissue. The

CT

Advantages

- Provides structural image of the brain *in vivo*
- Can be used in healthy and clinical participants
- Indicates areas of brain abnormality
- Relatively non-invasive

Disadvantages

- Indifferent spatial resolution
- Provides measure of structure, not ongoing activity
- Expensive and requires highly trained specialist staff (like all neuroimaging methods)

radioisotopes that became used were those emitting positrons. The combination of a positron and an electron would result in the annihilation of both, producing the emission of two gamma rays that travel in different directions. It was thought possible to detect these rays and locate their origin. This gave rise to positron emission tomography (PET).

Positron Emission Tomography (PET)

Posner and Raichle (1994) observed that: ‘A remarkable thing happened in the mid-1980s. For the first time we could actually look at pictures of the human brain while people thought. The pictures were of areas of increased blood flow caused by enhanced neural activity during mental effort’. What began in earnest in the 1980s has now enveloped much of neuroscience research. As Figure 1.14 shows, the number of neuroimaging studies (PET/fMRI) has multiplied twenty-fold since the 1980s.

In his article ‘If neuroimaging is the answer, what is the question?’ Kosslyn (1999) illustrated this ferocious acceleration of publication with a personal anecdote: ‘Attending a poster session at a recent meeting, I was reminded of the old adage, “to the man who has only a hammer, the whole world looks like a nail”. In this case, however, instead of a hammer, we had a magnetic resonance imaging machine and instead of nails we had a study’ (p. 1283).

Carpentry aside, neuroimaging studies that employ PET and fMRI (see later) have provided some interesting data about the role of brain regions – as indexed by changes in processes surrounding neurons – in a myriad of behaviours from simple listening to words, to having a conversation, perceiving fear or achieving an erection.

The first reported study of increased regional cerebral blood flow during cognition was made in 1928 (Fulton 1928). This noted increased blood flow over an arteriovenous malformation in the occipital lobe during reading. Positron Emission Tomography (PET), one of the newer brain imaging techniques, can provide a measure of brain function via the measurement of brain oxygen consumption, blood flow and glucose metabolism. Of these three measures, blood flow appears to be the most reliable (Raichle 1994).

Figure 1.14

The number of neuropsychological studies using PET and fMRI published from 1988 to 1998 (from Cabeza and Nyberg 2000. © 2000 by the Massachusetts Institute of Technology)

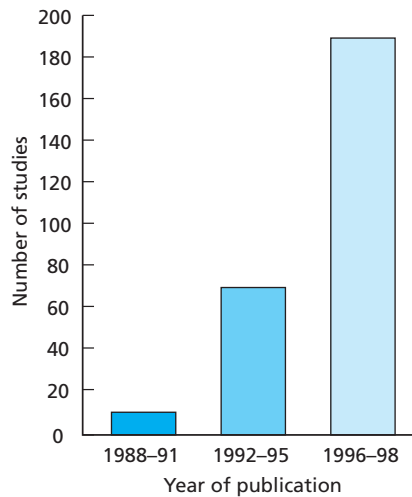

To measure glucose metabolism, radioactive glucose (usually 2-deoxyglucose, or 2DG) is injected into the participant and is taken up by metabolically active cells. The radioactive particles of the 2DG emit positrons, which are detected by a scanner designed to detect their emission. When positrons are emitted and collide with electrons, they form gamma rays, which exit the head and are detected. Those areas high in metabolic activity will produce more gamma rays, because they take up more glucose. The degree of gamma radiation is transformed into a three-dimensional colour-coded representation indicating regions that are high or low in metabolic activity or where there is increased blood flow.

Blood flow can be measured by injecting radioactively labelled water (hydrogen and oxygen-15). When the water decays, positrons are emitted. It takes about a minute for the water to reach the brain; once there it can provide an image of blood flow, based on the principle that when neurons become active, blood flow to them increases. It is a relatively safe method: with oxygen-15 having a half-life of two minutes, it takes about ten minutes for almost all of the substance to decay and become non-radioactive (Raichle 1994), thus reducing the chances of exposure to radiation.

Each trial is referred to as a scan and can take between 40 and 70 seconds to complete. To obtain a final image, PET investigations average responses across many participants or conditions. The rationale is similar to that for ERP recording: averaging reduces background noise and highlights areas of genuine activity. PET can therefore show changes in blood flow or metabolism within a task but not within trials within a task. On average, 6–10 scans are made per participant. PET also uses the method of subtraction to highlight those areas especially active during the performance of a particular task. In subtraction, blood flow or radioactive counts obtained during the resting stage are subtracted from counts obtained during functional activation, i.e. the experimental condition(s) when the participant is performing a task. The resulting image should then give an accurate representation of the specific regions activated by the task. This is called activation; if the experimental condition produces metabolism/blood flow that is lower than baseline, this is called deactivation. Subtraction does not identify every region that is active during a task – only those that differ from baseline. It is more than possible

that regions active during baseline are also experimentally active during task performance (Sergent 1994).

Furthermore, deactivation does not necessarily mean that the area ‘deactivated’ does not participate in a task. The assumption that the areas involved in a behaviour are the most active is actually false. In tasks with a motor or cognitive component, for example, practice usually results in a decrease in activation in those brain regions that were active during early trials, despite the person becoming better at the task (Mazziotta *et al.* 1991). Similarly, novel stimuli may generate activation, which then attenuates as the stimuli become more familiar (Vandenberghe *et al.* 1995). Individuals proficient in one language also produce less activation in language-related areas than they do in another language that they speak and understand less proficiently.

In a language task, the control or resting state may be subtracted from a condition in which the participant reads or listens to nouns (Petersen *et al.* 1988). The reading/listening condition may then be subtracted from a condition in which participants may recite nouns. This illustrates those regions responsible for speech production. Finally, the recitation condition may be subtracted from a condition in which the participant utters a verb associated with the noun. This highlights those regions responsible for processing the semantic associations between words. This technique has been used to investigate a number of language tasks as well as memory, visual perception and recognition tasks. Examples of images using this technique can be found in Plates 1.4 and 1.5.

PET provides quite a clear picture of areas of activation in living brains. It can highlight areas clearly to between 6 and 15 mm, providing adequate spatial resolution. However, whatever PET gains in spatial resolution, it loses in temporal resolution (activity is captured 40–60 seconds after the event) and in multiple averaging of participants. This last limitation is important given the inter-individual variability in cortical anatomy and the claimed ability of PET to be able to focus on activity in small areas of the cortex.

Single Photon Emission Computerized Tomography (SPECT)

Single photon emission computerized tomography (SPECT) works according to a similar principle to that seen in PET. Radioactively labelled radiopharmaceuticals – biochemicals that emit radiation – are injected into the bloodstream, and a scanner with sensitive sensors picks up the emission of gamma rays produced by the radioactively labelled blood. The scanner attached to the sensors then reviews the distribution of the radioactivity and reconstructs it in the form of a scan. The radioactive tracer currently used is ^{99m}Tc-hexamethylpropyleneamine oxime (HMPAO). It is called *single* photon emission computerized tomography because it captures activity at one given point in time, as if ‘locking in’ brain activity and relating it to a specific event.

PET

Advantages

- Can be used with most clinical and healthy subjects
- High spatial resolution
- Measure of neuronal activity (indexed by blood flow/metabolism) *in vivo*
- Gives three-dimensional representation of regional activity
- Can be used to measure brain activity during task performance

Disadvantages

- Invasive
- Poor temporal resolution (blood flow is slower than neural transmission)
- Cannot be used in children or premenopausal women (because of the injection of radioactive substances)
- Tasks must take longer than a minute
- Averaging does not take into account cortico-anatomical variation
- Expensive

Combining techniques: cognitive neuropsychology and neuroimaging

One of the aims of neuropsychology is to determine which systems are necessary for a behaviour and which are sufficient: which are absolutely needed and which will allow us to behave in a specific way. Neuroimaging studies have highlighted a number of brain regions that are activated during particular tasks, and studies of individuals with brain damage have shown how damage can disrupt quite specific functions. Combining the two techniques often allows researchers to see how data converge. For example, if the recognition of familiar faces involves one specific region of the brain, then damage to this region should impair face recognition. Complementarily, this region should be disproportionately active in healthy individuals undergoing a PET or fMRI scan or less active in the brain-injured patient.

Adapting this logic, Price *et al.* (1999) combined both approaches to study the way in which we judge the similarity in meaning of two words. In a variant of a standard task, neuroimaging researchers had found that if people were presented with the phrases 'palm tree' and 'deciduous tree' and asked which is closer in meaning to 'pyramid', activation was found in the inferior frontal cortex and in the extrasylvian temporal cortex (Vandenberghe *et al.* 1996a, b). However, what the finding cannot explain is which regions are necessary for the task and which are not.

Price *et al.* (1999) therefore tested a patient with a left cerebral artery infarct, which resulted in damage to the left frontal, temporal and parietal cortex. Despite the brain injury, patient SW could perform a similarities task. Why? One reason might be that the tissue surrounding the areas damaged had assumed this function. Another might be that the equivalent regions in the right hemisphere had compensated for the impaired areas. A final reason might simply be that none of the regions is actually necessary to perform the similarities task.

In an elegant experiment, Price *et al.* asked SW to perform the task during neuroimaging. He showed no activation in the left or right frontal cortex when he completed the task. However, his left extrasylvian temporal cortex did become activated, as Plate 1.6 shows.

This region and the frontal cortex are therefore sufficient to perform the task in healthy individuals, but the frontal cortex is not necessary. The study highlights an important point: that neuroimaging can be used to differentiate between brain regions that are sufficient and those that are necessary for function.

Magnetic Resonance Imaging (MRI)

Magnetic resonance imaging (MRI) is based on changes in the magnetic properties of atoms and was developed to observe the activity of atomic nuclei. It is an example of another technique developed independently by two people, Felix Bloch and Edward M. Purcell. It won them the Nobel Prize in 1952. Originally called nuclear magnetic resonance imaging (NMRI), the term 'nuclear', with its connotations of radiation, was later dropped in favour of the less emotive magnetic resonance imaging (Maier 1995).

MRI can detect protons (hydrogen nuclei), which respond like compass needles in the presence of a magnetic field. Each nucleus is a spinning, charged particle that generates a magnetic field (this is called a magnetic dipole movement). During scanning, a magnetic field is passed through the participant's head while the participant is lying inside a scanner (a narrow tube in which the entire body must fit). This scanner has a large magnet, which ensures that protons are in the upright position. When a radio frequency is passed through the head, the nuclei become excitable. As they begin to reorient to their own magnetic field, they produce reverberations or precesses (wobbles). These reverberations are then detected by the scanner. The reverberation produces an energy signal, which is measured by the scanner as the protons return to their original state. This produces excellent anatomical images, as seen in Figures 1.15(a) and (b) and Plate 1.7.

Figure 1.15

(a) Sagittal view of an MRI scan of a living human brain; (b) MRI scans taken from a patient with damage to Wernicke's area following cerebrovascular accident

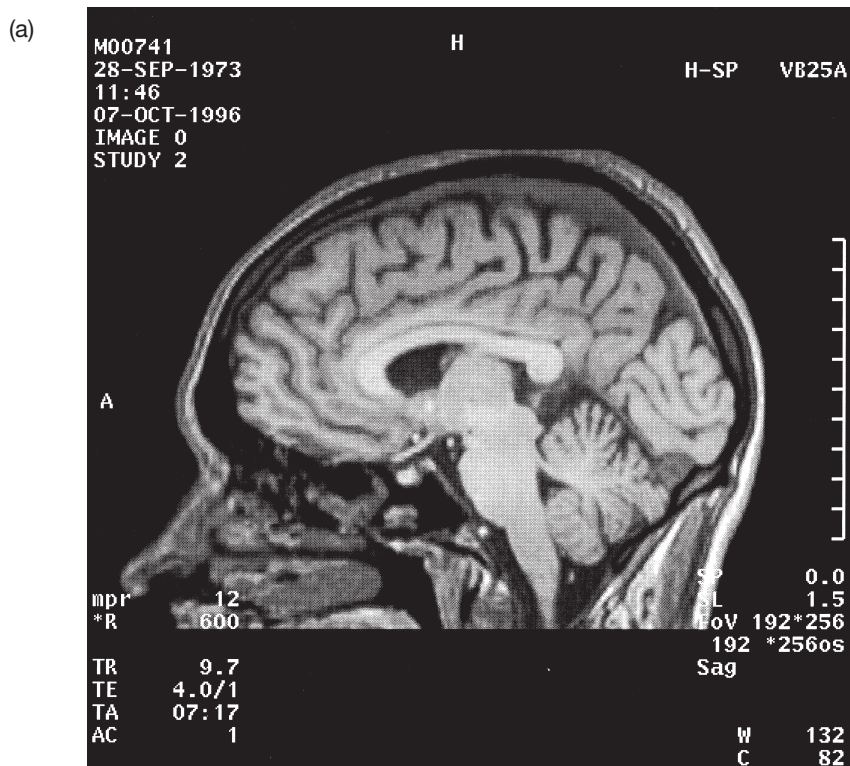
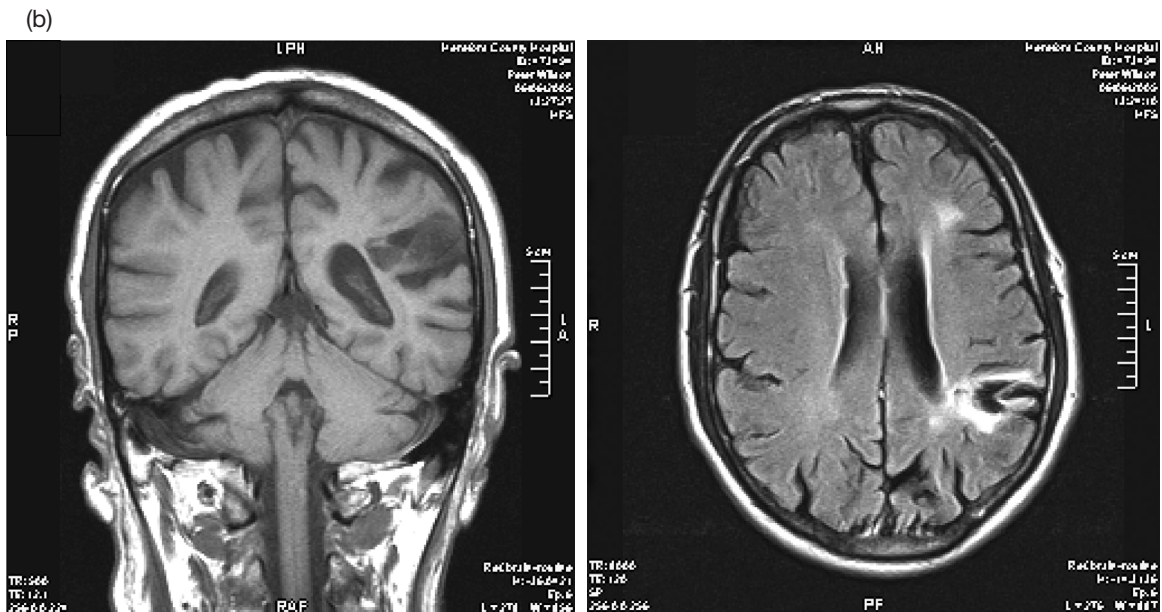

Figure 1.15 *continued*

MRI

Advantages

- Non-invasive and non-toxic
- Allows structural imaging
- Provides the best spatial resolution of current imaging techniques (1–2 mm)
- No known biological risk

Disadvantages

- Procedure difficult if participant is claustrophobic
- Magnet precludes introduction of ferromagnetic materials into testing environment
- Equipment producing radio frequencies must be shielded
- Obtaining good images from areas near to large cavities is difficult
- Transient scanner effects can produce one bad image out of ten or twenty
- As with PET, ensuring similar head placement for each participant is difficult
- Noisy procedure

Functional Magnetic Resonance Imaging (fMRI)

Until a short time ago, only structural images were possible with MRI, limiting its usefulness as a method for observing ongoing cognitive processing. Since the 1990s, it has become possible to use the technique to detect signals that PET cannot detect (Cohen and Bookheimer 1994). When neurons are active, increased oxygen reaches those active neurons. Yet these neurons exhibit anaerobic metabolism in that although increased blood flow accompanies increased neuronal activity (as PET can measure), the cells do not consume more oxygen. In fact, they use no more than if they were at rest. Thus, when increased blood flow occurs in the absence of oxygen consumption, the oxygen concentration of nearby blood vessels increases. It is this increase in oxygen concentration in blood flow that fMRI can detect. The relationship between oxygen, blood flow and MRI lies in the fact that the concentration of oxygen in blood can affect the magnetic properties of haemoglobin (Pauling 1935). MRI is able to detect these magnetic changes (Ogawa *et al.* 1990) and functionally induced changes (hence functional MRI).

Functional MRI has been used to study a variety of behaviour, from language difficulties in developmental dyslexia to face recognition, to personality and the recognition of emotions to being in love.

Applying fMRI: where does the brain recognize faces?

One current hypothesis in neuropsychology argues that specific brain regions are responsible for the recognition of faces, because the recognition of faces requires or involves a different mechanism to that involved in object recognition. Some patients with brain damage can tell the sex of a face but not identify it (even when it is very well known), a disorder called prosopagnosia. A large number of studies has shown that in normal viewers with no brain damage, one specific region of the brain is consistently activated during face perception (but not during general or visual object perception). This is called the fusiform face area (FFA) and is found in the temporal cortex.

To see whether the recognition of familiar faces utilizes different neural mechanisms to those involved in the recognition of familiar buildings, Gorno-Tempini and Price (2001) asked participants to view these two types of visual stimulus. In their fMRI study, they found that famous faces activated the FFA, as predicted, but that famous buildings activated different areas but ones known to be selectively active during the perception of buildings and that are dysfunctional or damaged in people who have difficulty in perceiving streets, landscapes and monuments (a disorder called landmark agnosia). Plate 1.8 shows the stimuli and their effect on brain activation.

fMRI

Advantages

- Measures direct changes in brain tissue from normal and clinical participants
- Non-invasive and non-toxic
- Allows functional imaging

- Provides the best spatial resolution of current imaging techniques (1–2 mm)
- No known biological risk
- More widely available and cheaper than PET

Disadvantages

- Decreases in venous oxygen content are not observed by fMRI
- Procedure difficult if participant is claustrophobic
- Poor temporal resolution (four images per second is current norm)
- Magnet precludes introduction of ferromagnetic materials into testing environment
- Equipment producing radio frequencies must be shielded
- Some brain areas may be more efficient at regulating blood supply than others
- Obtaining good images from areas near to large cavities is difficult
- Is susceptible to movement artifact
- Transient scanner effects can produce one bad image out of ten or twenty
- Ensuring similar head placement for each participant is difficult

Discussion point: are neuroimaging studies reliable and valid?

Since 1988, the number of published PET and fMRI studies has increased 30-fold, from ten to around 200 or so by 1998 (it has probably accelerated since then). Two obvious reasons explain the explosion: (1) the establishment of neuroimaging equipment in academic centres, together with an increasing collaboration between hospitals and universities; and (2) a recognition that these techniques are powerful tools for allowing scientists to observe apparent brain function and neuroanatomy.

The sizeable number of neuroimaging studies now published allows us to evaluate the degree of agreement and variability between centres. In a review of the neuroimaging studies available at the time, Gold *et al.* (1997) found some variability between research groups, as one might expect, but consistency was more likely when multiple scans were averaged than when single scans were taken, probably because the greater sampling led to a reduction in the signal-to-noise ratio. Experiments presenting visual stimuli were found to produce the most consistent activations, and the effect sizes for studies of vision were larger than those for cognition, probably reflecting the reduced degree of inter-subject variability/subjectivity in sensory processing. Curiously, Gold *et al.* found that the smaller the sample, the larger the effect size (although both factors are theoretically unrelated to each other). They suggest that this reflects the more careful selection of the participants in these studies.

A recent review concluded that the reliability and validity of PET and fMRI were good, but there continued to be some variability between centres – the most important differences existed at the methodological and statistical level, with groups adopting different approaches depending on their needs (Billingsley-Marshall *et al.* 2004). The lack of uniformity – in terms of statistical and methodological protocol – makes comparisons

between groups' findings problematic, because 'like' are not compared with 'like'. In general, however, PET showed good concordance between 'language maps' and areas of brain damage, i.e. PET studies of language processes showed activation in those areas that, when damaged, produced impairments in those processes; they supported the findings from cognitive neuropsychology. However, spatial and temporal resolution were poor. Neuroimaging studies also showed that regions other than the region of interest were activated during task performance, suggesting that while brain injury shows which areas of the brain are necessary for function, neuroimaging does not.

As the studies in this book show, there is sometimes great variation in the areas activated by tasks in neuroimaging experiments – the brain always seems to produce more activity than it efficiently needs to. However, there is also some consistency in the regions activated by specific tasks. For example, the part of the brain responsible for processing the sounds of words (its phonology) has been consistently localized in a region of the temporal cortex (see Cabeza and Nyberg (2000) for a review). Retrieval of autobiographical information from memory appears to be closely associated with activity in the left frontal lobe, whereas encoding (learning) material is associated with right frontal activity.

Two studies have shown how findings produced by different research centres and equipment can converge. A Japanese study of verb generation using two different PET scanners found that both scanners showed the same or similar activation during the task (Tatsumi *et al.* 1999) and that this activation was found in areas similar to those active during verb generation in English speakers. A comparison of eight European and four non-European PET centres found that a simple language task – silently generating verbs to a series of auditorily presented nouns – generated activity in the same regions (parts of the left temporal lobe, parts of the frontal cortex and other cortical regions) in over 90 percent of the centres but generated less consistent activation in other brain areas, such as other regions of the cortex and structures beneath the cortex (Poline *et al.* 1996).

There is a more basic question to which neuroimaging studies can give only an equivocal answer. Do these techniques measure the activity of neurons? Although described as neuroimaging techniques – and researchers talk of increases in brain activation or neural involvement – PET and fMRI do not measure the activity of actual neurons. Instead, they measure events surrounding neurons, such as the blood flow around them or the oxygen that is delivered to them. Strictly speaking, therefore, the techniques are indirect measures of blood flow to, and oxygen consumption by, brain cells. Many assumptions about how the brain works are based on these fairly indirect measures of brain function.

Biochemical techniques

Sometimes a clearer picture of the neurophysiology of brain function can be provided by psychopharmacological techniques. Often these involve the administration of drugs to alleviate the symptoms of particular disorders. Therefore, alterations in symptoms brought about by the administration of the drug might allow scientists to examine the role of the drug and its induced neural changes in the appearance of a particular disorder. These disorders may be characterized by cognitive or behavioural irregularities or deficits such as chronic depression, mania, paranoia and thought disturbance (schizophrenia), motor disturbance (Parkinson's disease, Huntington's disease), memory disturbances

(Korsakoff's psychosis) and deteriorating intellectual performance (dementia). A number of the theories of localization of depressive illness, for example, has focused narrowly on a few neurotransmitters and their systems because these appear to be the ones primarily involved. These are discussed in Chapter 12.

Another biochemical technique used for quite different purposes is the Wada test, pioneered by Wada and Rasmussen in the 1950s and 1960s. This involves injecting sodium amytal into the carotid artery, briefly anaesthetizing the ipsilateral hemisphere, i.e. the one adjacent to the artery (Wada and Rasmussen 1960). The technique utilizes the fact that humans have their language localized in one hemisphere. Its purpose is to localize the language areas of the patient's brain before he or she undergoes surgery. Localizing the function will, therefore, inform the surgeon of which areas to avoid during surgery.

At the beginning of the procedure, the patient begins counting from 1 to 20 with their arms raised, palms down and fingers spread. An injection of 100 g of amobarbitol sodium follows (this takes about four to five seconds). The patient is then asked to follow a command (such as identifying his or her midline 'touch your nose'). Thirty to forty-five seconds after the injection, a memory test may also be administered. This takes the form of a series of eight objects presented to the patient and identified. The patient's recognition memory, i.e. the ability to recognize a series of target objects/names from a series of target and distractor objects/names, is tested after the language tasks.

During the anaesthesia, which lasts between four and ten minutes, the contralateral arm and leg become flaccid, and there is little contralateral somatosensory response. Injection into the speech hemisphere results in an almost complete arrest of speech, lasting minutes; injection into the non-dominant hemisphere also produces speech impairments, but these are brief. The language tasks used in this technique include expressive language and counting (e.g. the counting task described above; the recitation of the days of the week backwards and forwards); comprehension (e.g. the midline task above and other exercises such as following the command 'stick out your tongue'); naming (e.g. patients name drawings of a jacket or watch, or parts of them); repetition and reading. Performance on all of these tests is rated according to severity of dysfunction. In surgical patients, this is the best technique for demonstrating localization of language function.

Biochemical techniques

Advantages

- Provides the best method of hemispheric localization of speech

Disadvantages

- Invasive
- Cannot be used in healthy, non-clinical participants
- Cannot provide information at the molecular and regional level

Brain electrical stimulation

The technique of passing an electrical current across the brain using an electrode and observing its effects was most strikingly described by the American surgeon Wilder Penfield and his colleagues in the 1930s. Penfield found that stimulating certain parts of the brains of patients undergoing surgery for epilepsy produced stereotypical behaviour such as reports of sensations (tingling or tickling) or uttering groans or cries (Penfield and Jasper 1954). Stimulation was applied to determine the regions responsible for speech, so that these could be avoided. Penfield also reported that a patient whose brain was stimulated would recall a melody or a song from the distant past. However, the remarkable recall of memories and melodies occurred in only a small number of participants (about 8 percent).

The experiments usefully described the regions producing motor movements (Penfield and Rasmussen 1950) and associated stimulation of the primary motor cortex (specifically a part called the precentral gyrus) with the movement of various parts of the body. When the results of stimulation are transposed onto a homunculus (a figure showing the parts of the body with the size of the parts drawn in proportion to the number of receptors that each part has), the figure is characterized by large hands and a large face (see Figure 1.16). This is entirely due to the fact that these parts of the body perform the finest and most complex movements and therefore have the largest number of receptors.

While the technique is used principally to guide surgery rather than to provide neuropsychological data, it continues to provide information on functions such as language. Duffau *et al.* (2005), for example, electrically stimulated regions of the cortex in seventeen

Figure 1.16

A motor homunculus (from Carlson, Neil, R. *Foundations of Physiological Psychology*, 3rd edition. Published by Allyn and Bacon, Boston, MA. Copyright © 1995 by Pearson Education. Reprinted by permission of the publisher)

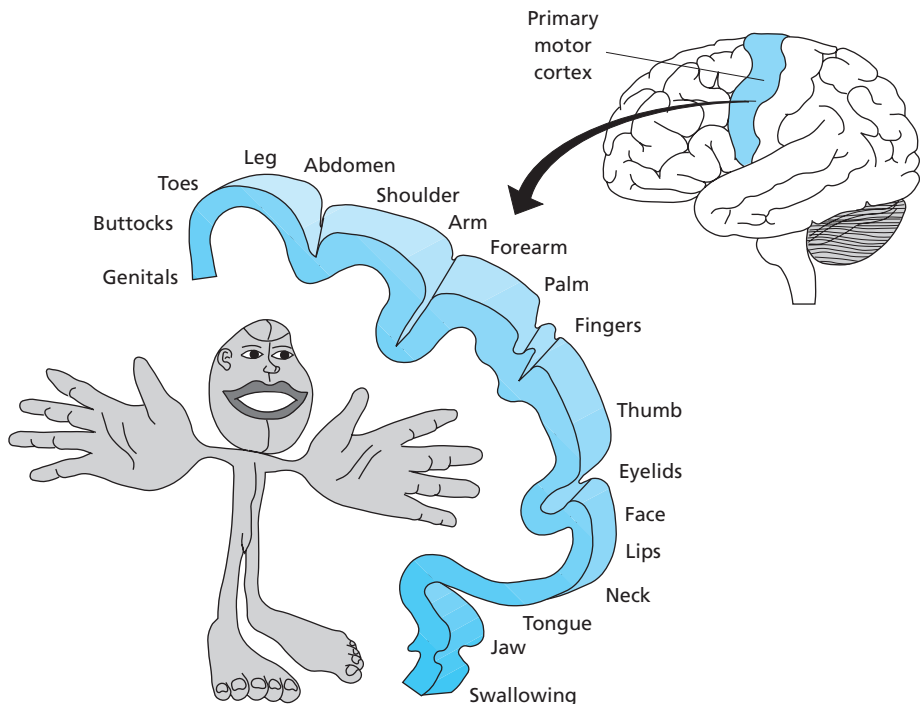

patients undergoing surgery for removal of a glioma and found that stimulation in the cortex and the subcortex produced transient paraphasia – speech errors that involve the incorrect use of sounds, syllables or words. Duffau *et al.* mapped these regions onto the brain areas identified by MRI after surgery and revealed a network of brain regions involved in semantic processing specifically located in the subcortex.

Modern brain stimulation: trans-cranial magnetic stimulation

Despite having its origins in the nineteenth century, a relatively new non-invasive technique for studying localization is trans-cranial magnetic stimulation (TMS), which involves modulating cortical activity by passing alternating magnetic fields across the scalp (Burt *et al.* 2002). The consequence of exposure to these fields is that electrical currents are induced in the cortex, and the excitability of the cortex is subsequently increased or decreased. These effects can last a few seconds or minutes to a few weeks. The technique's benefits to neuropsychology are that it can produce transient impairment or improvements in cognition non-invasively. Figure 1.17 shows a TMS machine.

Before describing its application in neuropsychology, it is useful to understand a little about the physics underlying TMS. It works by using two electromagnetic principles: Ampere's law and Faraday's law. The former states that a magnetic field will be generated

Figure 1.17

A typical rTMS procedure (University of Durham/Simon Fraser/Science Photo Library)



by an alternating current; the latter states that an electric current can be generated by alternating magnetic fields. The two principles are practised sequentially in TMS.

In practice, a metal coil is placed on a participant's scalp. The alternating electrical current in the coil produces an alternating magnetic field at right angles to the current generated in the coil. This alternating magnetic field then passes through to the cortex and creates an electrical current in the part of the brain (around 1 to 2 cm worth) beneath the coil. The technique is apparently safe – the most likely danger, if a danger exists, is of a seizure being generated during repeated stimulation. According to Burt *et al.* (2002), no seizure has been reported in the literature since 1996. Sometimes, headaches can follow as can slight periods of mania; scalp facial muscles might twitch.

In TMS, the magnetic fields – or 'pulses' – can be presented either singly, in pairs a few seconds apart or in quick succession over a period of minutes. These are called single-pulse TMS, paired-pulse TMS and rTMS, respectively. Testing sessions normally last between 20 minutes and an hour. If the stimulation is high frequency, an increase in blood flow is observed; if stimulation is low, excitability is reduced (Chen *et al.* 1997). Blood flow and cortical excitability are thought to be correlates in this sense, although the change in blood flow may occur away from the region that is cortically excited.

TMS has been used to study a range of behaviour of psychological interest (Jahanshahi and Rothwell 2000), but the impact of the technique (the rTMS variant) has perhaps been greatest in psychiatry, where in some studies the technique has been shown to have an antidepressant effect. The first study using TMS in a psychiatric sample found such effects, although modest, in two depressed patients (Hoflich *et al.* 1993). Catafau *et al.* (2001) reported that blood flow to the prefrontal cortex was increased in depressed individuals following rTMS, although the effect has not been replicated. Kimbrell *et al.* (1999) suggest that the inconsistency may stem from the type of TMS employed and the effects they have: high-frequency rTMS may increase the efficiency of synapses, but low-frequency stimulation may have the opposite effect. According to a meta-analysis of the therapeutic effects of TMS on depression, Burt *et al.* (2002) found that there was a 24–37 percent reduction in depressive symptoms or depression scores. They suggest that TMS may have an additive and additional effect (five to ten sessions were administered over one to two weeks), providing short-term antidepressant relief while the antidepressant drugs are beginning to work.

The technique has shown some positive effects in mania (Grisaru *et al.* 1998), limited effectiveness in obsessive–compulsive disorder (Alonso *et al.* 2001) and promising effects in Post-Traumatic Stress Disorder (Grisaru *et al.* 1998b). In schizophrenia, treatment has been shown to reduce auditory hallucinations in twelve patients (Hoffman *et al.* 1999, 2000).

In healthy individuals, the effect of TMS on mood is variable: one study found a decrease in happiness following left prefrontal cortex stimulation and increased sadness during right frontal stimulation (George *et al.* 1996), with another showing increases in sadness (and decreases in happiness) following left prefrontal stimulation (Pascual-Leone *et al.* 1996). However, other studies (e.g. Grisaru *et al.* 2001) have found no effect of TMS (especially slow TMS) on mood.

The effect of TMS in normal, healthy individuals is analogous to the effect of a lesion – the transient stimulation produces a transient disruption of function (although, obviously, with no damage, permanent or otherwise). Neuropsychology has exploited this analogy in a number of ways, and several studies have shown how specific functions, especially language, thought to be mediated by specific regions have been disrupted following TMS. The application of the technique has been guided by neuroimaging studies showing task-specific activation in specific areas or single-case studies showing

function-specific impairments. Unlike neuroimaging, where activation is correlated with behaviour and may not be necessary to produce it, TMS directly stimulates brain regions, and the consequences can be observed. The technique has been found to disrupt verbal working memory (Mottaghy *et al.* 2002), verb generation (Shapiro *et al.* 2001) and speech (Stewart *et al.* 2001). Other studies have reported improvements in picture naming following TMS stimulation of Wernicke's area (Topper *et al.* 1998).

Applying TMS: disrupting the memory for sound

A recent study investigated whether stimulation of the frontal operculum in the frontal cortex disrupted the recall of the sound of a visually presented word (Nixon *et al.* 2004). In neuroimaging studies, a region called the inferior frontal gyrus, which forms the back of the frontal operculum, has been implicated in phonological processing (making decisions about the different sounds in words) and subvocal rehearsal of speech. Nixon *et al.* used rTMS to study participants during the performance of a delayed phonological matching task.

In this task, the participant is asked to read a visually presented word silently and remember it during a delay period. After the delay, two phonologically legal non-words (not real words, but easily pronounceable) are presented, and the participant has to indicate which sounds more like the remembered word. TMS was delivered during either the delay phase or the decision phase.

When delivered during active remembering, rTMS impaired accuracy at the decision task. When delivered at the point at which a decision was being made (comparing the word with the non-word), there was no disruption of performance. A comparison task, in which the stimuli were non-verbal, produced no disruption during either phase, suggesting that these areas are especially implicated in verbal phonological memory. Stimulation to an anterior site (the pars triangularis) did not produce any disruption either, as Plate 1.9 shows.

TMS

Advantages

- Good for localizing low-level behaviour such as sensation or motor movement
- Can be used to elicit improvement or impairment in function
- Non-invasive
- Relatively safe

Disadvantages

- Cannot provide consistent information about higher function (e.g. memory)
- Crude measure of localization – precision of regional stimulation is questionable

Lateralization techniques

Although fundamentally concerned with localization of function, neuropsychology is also interested in whether the different cerebral hemispheres perform different functions. Single-case studies, EEG and neuroimaging techniques can provide such information, but other neuropsychological tests examine laterality more explicitly. The most commonly used techniques are dichotic listening, visual hemifield studies and lateral eye movement.

Dichotic listening refers to the presentation of different auditory verbal stimuli (e.g. a word, an uttered digit or a nonsense syllable) simultaneously to the two ears via headphones, as illustrated in Figure 1.18. When the participant indicates which word he or she heard, there is usually a right ear advantage (REA) – the participant identifies the word presented to the right ear more accurately.

Doreen Kimura, in a well-known study, presented two groups of patients with two different spoken digits in pairs to both ears and asked them to indicate what they heard. Patients with left temporal lobe damage performed more poorly than patients with right temporal lobe injury (Kimura 1961), suggesting that verbal auditory material could not be understood by the damaged left (language-based) hemisphere. However, auditory information is received by both hemispheres (the auditory cortex is found in the temporal lobes). To account for this, Kimura argued that during dichotic listening, the ipsilateral auditory pathways (from the left ear to the left hemisphere and from the right ear to the right hemisphere) were suppressed by the contralateral pathway (the left ear to the right hemisphere and the right ear to the left hemisphere). So, the superiority of the right ear could have been due to information not getting to the right hemisphere because the left hemisphere suppressed the signal or because the information that was transferred inter-hemispherically was lost on its way from the ipsilateral to the contralateral hemisphere. Interestingly, although there appears to be a consistent REA for verbal stimuli (see, for example, Dane and Bayirli 1998), there appears to be a left ear superiority for the processing of musical chords and melodies, at least in non-musicians (Gordon 1980).

Visual field (VF) studies, or visual hemifield studies, usually involve the projection of a visual stimulus to one half of the participant's visual field extremely quickly while the participant focuses on a central fixation spot (usually a cross on a white board). The machine presenting the stimulus, a tachistoscope, is capable of presenting images, words, shapes, objects, etc. at millisecond speed (see Figure 1.19). The majority of VF studies

Figure 1.18

The pathway of auditory signals during dichotic listening

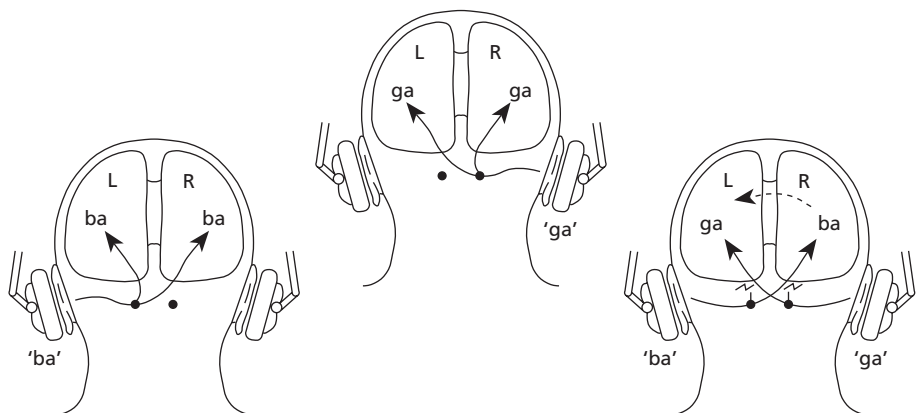
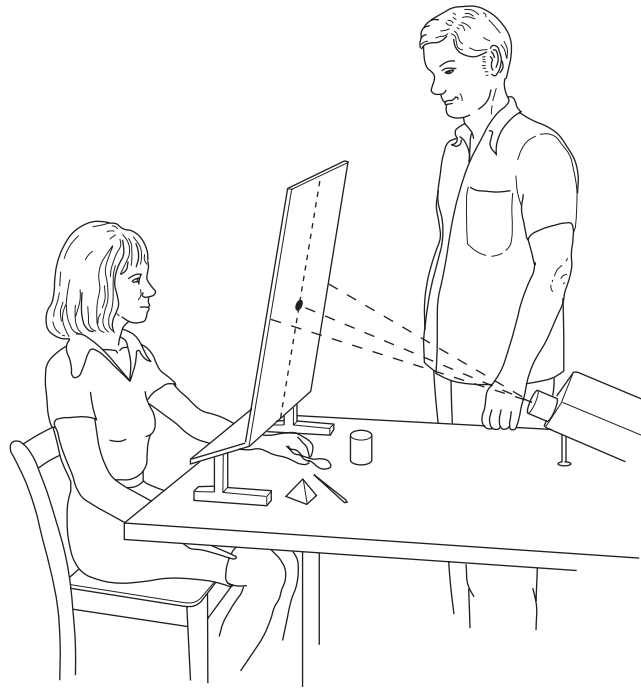

Figure 1.19

A typical testing session involving the tachistoscopic presentation of stimuli. As the subject fixates on a central spot, an image can be flashed to that spot or to its left or right



nowadays uses computerized versions of a tachistoscope. The technique is useful because it exploits the fact that the visual system is crossed – that is, at a point along its pathway (the optic chiasm), information is transferred from the left retina to the right hemisphere and from the right retina to the left hemisphere, as Figure 1.20 shows.

Using this technique, researchers have found that words flashed to the right visual field (RVF) and processed by the left hemisphere are better identified than words presented to the left visual field (LVF) and processed by the right hemisphere (Bryden 1965). Right hemisphere (LVF) advantage has been found for naming pictorial stimuli and for identification requiring visuospatial skill (Kimura 1969). This technique has been (and continues to be) widely used to examine the performance of split-brain patients and is used effectively with normal, healthy participants (Resnick *et al.* 1994), although an RVF advantage at one testing session can evaporate at the next testing session. An example of how this technique has been used can be seen in the box below.

Figure 1.20 The crossover seen in the visual pathway

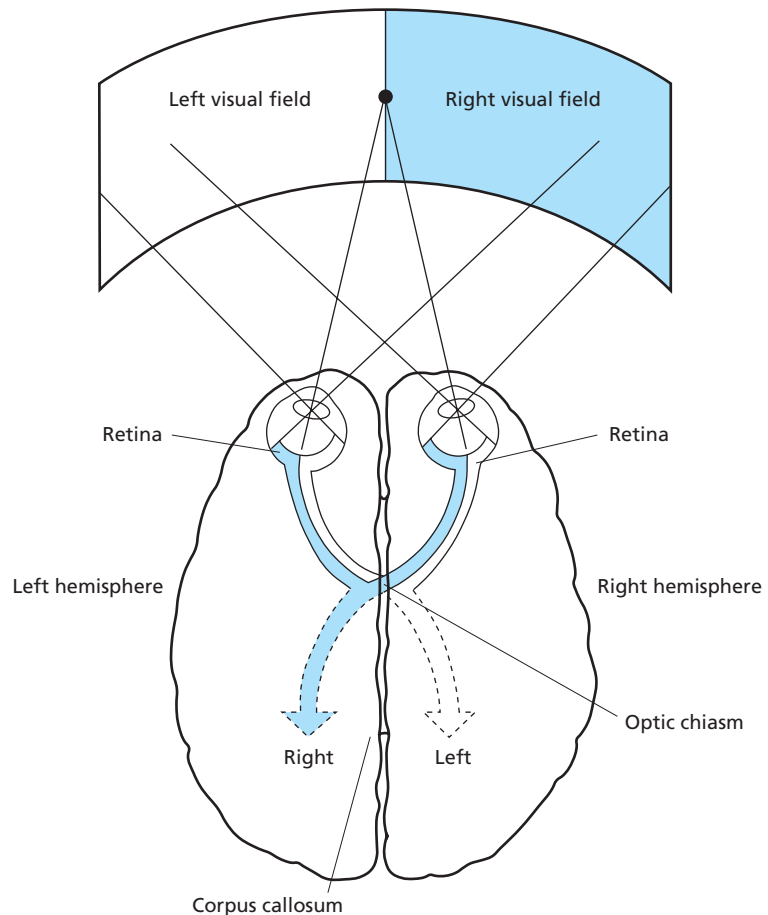

Applying lateralization techniques: problem solving and the right hemisphere

One general theory of localization of function suggests that the right hemisphere is more 'creative' or 'insightful' than the left. That is, it can complete creativity tasks more proficiently than can the left. Such generalizations need to be treated with a pinch of salt – even the word 'creativity' generates a great deal of definitional debate – but experiments that are designed to test general hypotheses in a controlled and specific way can help to modify such generalist views. A visual field study of insight attempted to do this by having participants undertake a series of problem-solving exercises, such as generating a word that would be associated with three others (Bowden and Beeman 1998). For example, if presented with the words 'pie', 'luck' and 'belly', the participant should respond with 'pot'.

After the words had been presented sequentially on a computer monitor, the participant was given 15 seconds to solve the puzzle. A single word was then presented to

the left or right visual field – this word would be either the solution word or an unrelated word. The length of time taken to read the word was measured.

As expected from the literature, words were read more quickly when presented in the right visual field. However, in participants who had solved the problems, the solution words presented to the right hemisphere were read more quickly than those presented to the left, as Figure 1.21 shows. In a second experiment, a right hemisphere advantage was also found for recognizing words for unsolved problems.

The results suggest that the right hemisphere can be involved in problem solving in two ways: it may activate solution-relevant information or recognize a solution. However, the findings do not demonstrate that the right hemisphere can solve these problems exclusively, simply that individuals respond faster when a solution is presented to the right hemisphere.

Figure 1.21

The naming times for the solution and for unrelated target words in the solved and unsolved problem conditions. LH = left hemisphere; RH = right hemisphere (from Bowden and Beeman 1998)

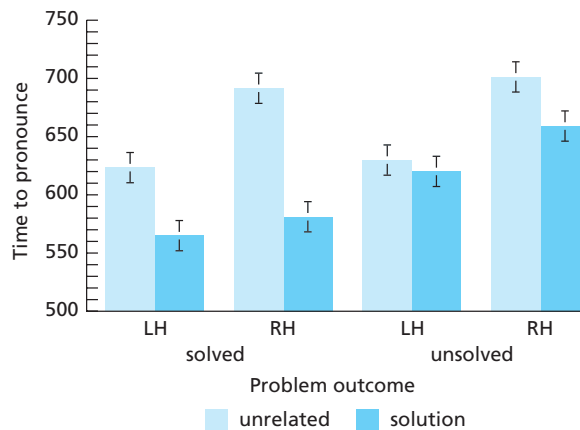

There is also evidence that participants may not be able to maintain fixation accurately and consistently when instructed to do so. Jordan *et al.* (1998) found that when participants were instructed to fixate centrally, there was great variability in their ability to do this, i.e. participants did not fixate centrally (most fixated to the right of the central fixation spot). However, if this was monitored via eye tracking, participants could be guided to fixate appropriately. This finding could have important implications for studies in which the procedure is so sensitive that there can be no deviation from the fixation point. Jordan *et al.* suggest that whereas the magnitude of the RVF advantage was comparable in the conditions where central fixation was ensured and where it was variable, they also found that shifting the fixation location could significantly affect participants' behaviour – performance with RVF stimuli was more greatly affected than performance with LVF stimuli.

A review of the reliability and validity of laterality measures drew mixed conclusions (Voyer 1998). The reliability of the techniques was quite good (the correlation was 0.68), and validity varied from significant to low. However, the reliability was greater when stimuli were presented auditorily and when tasks used verbal stimuli.

Lateralization techniques

Advantages

- Non-invasive
- Can be used in any participant with intact auditory and visual system
- Inexpensive and easy to set up
- Reliability is fair

Disadvantages

- Indirect measure of lateralization
- Subjects' performance can be variable (ear and visual field advantage can change from one testing session to another)
- Validity is variable

Discussion point: what is it like to undergo a brain scan?

The Wellcome Department of Imaging Neuroscience in Queen Square, London, houses one of the most active neuroimaging facilities in the world. It undertakes several projects involving cognition and emotion and how the brain behaves while it experiences these psychological phenomena. Among these projects are brain imaging studies of depression, memory, motor behaviour, dyslexia, and visual and spatial perception. However, one of its strongest research areas is the study of the neuroanatomy of language: word recognition, reception, comprehension and production.

I had been asked by a colleague to participate in a PET and MRI experiment on word and symbol recognition. On arrival, I was taken to the basement of the building that houses the scanners. I was struck by the spotlessness of the place: cleaners seem to be constantly on duty.

A short length of bright white corridor brought us to the radiographers' room and, opposite that, the MRI and PET laboratories. I am told to remove all metal objects from my body (the MRI scanner is a magnet) and complete a form requesting information about my health. The radiographer leads me into a small, bare room with no defining features apart from an MRI scanner, which has a narrow, bed-like structure emerging from a hole in the middle of the scanner. This is large enough to accommodate a prostrate human body. I am asked to lie on the bed and to wear a set of earplugs, because the scanning is noisy but not uncomfortably loud (it is about 9 dB). I am given a panic button, which I can press at any time when I am inside the scanner to attract attention. I am told to keep my head absolutely still (it is placed between two padded clamps), because any head movement can contaminate the spatial resolution of the image of my brain. The bed, remotely controlled by the radiographer, is moved inside the scanner.

My head gradually makes its way from the brightness of the room into the relative darkness of the cylindrical interior of the scanner. Even if I had wanted to move, there

is not much room to do so. An intercom keeps me in contact with the radiographer at all times. Then the scanning starts. Each scan sounds like an extremely loud but muffled buzz. The first stage of scanning ensures that my head is positioned at the right angle and that my image can be obtained clearly by the radiographer. Then, for what seemed like twenty minutes but was actually about ten, the machine scans my brain.

The scanning over, the bed slides out of the scanner and I can move again. There is no disorientation, but I feel a little woozy, not surprisingly given that I had been prostrate for ten minutes with plugs in my ears. I am taken from the MRI room to the PET laboratory. Before participating, I am told to visit the lavatory, because the experiment is about two hours long (twelve scans of six minutes each) and I will be lying still on my back for this time. There would be no opportunity for bladder relief during the experiment.

The PET laboratory comprises two rooms: a small control room where the participant is monitored, the presentation of stimuli is controlled and images are collected, and another much larger room that houses the PET scanner. This scanner is a little like the MRI scanner in that it also has a cylindrical hole, but it is easier to walk around because it is not designed to accommodate the whole body. Before lying on the bed extending from the scanner, marks are placed on my face, which act as the scanner's reference points. These are checked between scans. A plastic helmet with Velcro straps is placed on my head, which helps to keep it in place while the imaging occurs. Lying down on the bed, my left arm is exposed and a canula is placed inside my vein by a clinician. It is a little like giving blood. The canula is then attached to a tube, which automatically injects a radioactive isotope into my bloodstream at prescribed intervals. Any kink in the tube results in the automatic ringing of an alarm, warning the experimenter that the flow has been obstructed. The level of radioactivity is relatively low and harmless, the equivalent of taking a barium meal. Nonetheless, you are allowed to be PET scanned only once in twelve months for reasons of health and safety, and premenopausal women are never PET scanned, because of possible complications with childbirth.

Unlike the MRI procedure, the whole body does not enter the scanner during PET scanning. Instead, the top part of the head enters the hollow middle of the scanner. This allows the participant to observe any experimental stimuli presented. In this case, an overhead computer monitor was placed in my line of vision in order to present stimuli to which I would respond using a keypad kept to my right. A blanket covered my body to prevent me getting cold (the cool environment is necessary for the computers to work efficiently). My task is to indicate whether real words, pseudowords (legally spelled but nonsense words), and false fonts (a type of print) contained letters that rose above the midline of the word (called ascenders). For example, no letter in the word 'car' rises above the midline, but the 't' in 'cat' does. The aim of the experiment is to discover whether normal and dyslexic readers use different parts of their cerebral machinery in making these decisions.

The experimenter informs me that the experiment will begin in about two minutes, dims the lights and leaves the room. Two minutes later, I have to indicate using one of two buttons next to my right hand whether a word has a letter above the midline in a series of about twelve presented words. Because PET relies on averaging activity across trials, there were a number of trials (hence the two hours lying still). After each trial, the experimenter checks that my head is in the correct position.

Reclining for two hours makes you relaxed (especially if you are tested at 8.30 in the morning), and after the experiment I experienced no discomfort. I removed the helmet and was led out of the scanning room to observe my MRI scans, which can be

printed like a Word document. An example of one of these appears in Figure 1.22. I am assured that this is normal.

Figure 1.22 The author's MRI scan

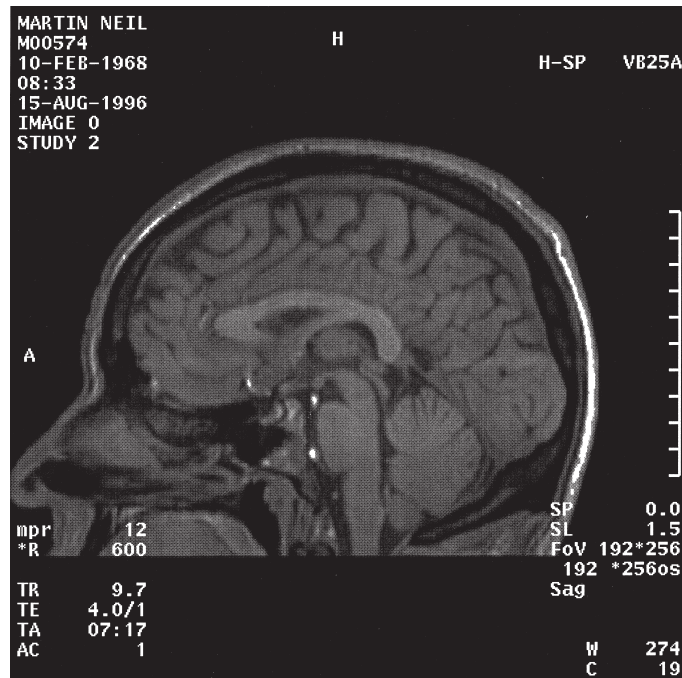

Summary

The aim of human neuropsychology is to understand the relationship between the brain's activity and structure and its function; it has a long history dating back to the ancient Greeks. The discipline's historical landmarks include Golgi's method of staining brain tissue, which allowed the observation of tissue's structure; Cajal's discovery that the nervous system was made up of neurons; Helmholtz's discovery that neurons communicate with each other via electrical signals; Gall's notion that skull protuberances resulted from underlying active cortical regions; Broca's and Wernicke's *post mortem* studies of the lateralization of language production and comprehension; and Fritsch and Hitzig's studies of localization of motor function in dogs. Current methods of studying brain structure and function include EEG (electroencephalography), ERP (event-related potential), CT (Computerized Tomography), MEG (magnetoencephalography), PET (Positron Emission Tomography), MRI (Magnetic Resonance Imaging), fMRI (functional Magnetic Resonance Imaging), computational modelling, trans-cranial magnetic stimulation (TMS), dichotic listening and visual field procedures. However, much of the information derived about brain function comes from the study of brain-damaged individuals or individuals who have undergone brain surgery (single-case studies).

Recommended further reading

General neuropsychology

- Finger, S. (2000). *Minds Behind the Brain*. Oxford: Oxford University Press.
- Kandel, E.R. and Squire, L.R. (2000). Neuroscience: breaking down scientific barriers to the study of brain and mind. *Science*, 290, 1113–20.
- Kinsbourne, M. (1998). Unity and diversity in the human brain: evidence from injury. *Daedalus*, 127, 2, 233–56.
- Kosslyn, S.M., Cacioppo, J.T., Davidson, R.J., Hugdahl, K., Lovallo, W.R., Spiegel, D. and Rose, R. (2002). Bridging psychology and biology. *American Psychologist*, 57, 5, 341–51.
- Krull, K.R. and Adams, R.L. (1997). Problems in neuropsychological research methodology. In M.E. Maurish and J.A. Moses (eds), *Clinical Neuropsychology*. New Jersey: Lawrence Erlbaum.
- McCarthy, R.A. (2001). Is the mind a cauliflower or an onion? British insights into cognitive organization from the study of abnormal function. *British Journal of Psychology*, 92, 171–92.
- Squire, L.R. (2001). *The History of Neuroscience in Autobiography*. Oxford: Academic Press.
- Stringer, A., Cooley, E. and Christensen, A.-L. (2002). *Pathways to Prominence in Neuropsychology*. Hove, UK: Psychology Press.

Single-case studies

- Caramazza, A. (1992). Is cognitive neuropsychology possible? *Journal of Cognitive Neuroscience*, 4, 1, 80–95.
- Code, C., Wallesch, C.-W., Joannette, Y. and Lecours, A.R. (1996). *Classic Cases in Neuropsychology*. Hove, UK: Psychology Press.
- Code, C., Wallesch, C.-W., Joannette, Y. and Lecours, A.R. (2002). *Classic Cases in Neuropsychology*, Vol. 2. Hove, UK: Psychology Press.
- Kosslyn, S.M. and Intrilligator, J.M. (1992). Is cognitive neuropsychology plausible? The perils of sitting on a one-legged stool. *Journal of Cognitive Neuroscience*, 4, 1, 96–106.
- McCloskey, M. (1997). Theory and evidence in cognitive neuropsychology: a ‘radical’ response to Robertson, Knight, Rafal and Shimamura (1993). *Journal of Experimental Psychology: Learning, Memory and Cognition*, 19, 3, 718–34.
- Price, C.J., Mummery, C.J., Moore, C.J., Frackowiak, R.S.J. and Friston, K.J. (1999). Delineating necessary and sufficient neural systems with functional imaging studies of neuropsychological patients. *Journal of Cognitive Neuroscience*, 11, 4, 371–82.
- Robertson, L.C., Knight, R.T., Rafal, R. and Shimamura, A.P. (1993). Cognitive neuropsychology is more than single-case studies. *Journal of Experimental Psychology: Learning, Memory and Cognition*, 19, 3, 710–17.
- Semenza, C. (1996). Methodological issues. In J.G. Beaumont, P.M. Kenealy and M.J.C. Rogers (eds), *The Blackwell Dictionary of Neuropsychology*. Oxford: Basil Blackwell.
- Shallice, T. (1988). *From Neuropsychology to Mental Structure*. Cambridge: Cambridge University Press.
- Sokol, S., McCloskey, M., Cohen, N.J. and Aliminosa, D. (1991). Cognitive representations and processes in arithmetic: inferences from the performance of brain-damaged subjects. *Journal of Experimental Psychology: Learning, Memory and Cognition*, 17, 3, 355–76.
- Special issue of *Cognitive Neuropsychology* (2004), vol. 21, issue 1.

Psychophysiology

- Andreassi, J.L. (2001). *Psychophysiology: Human Behaviour and Physiological Response* (4th edition). Hove, UK: Lawrence Erlbaum.
- Picton, T.W., Bentin, S., Berg, P., Donchin, E., Hillyard, S.A., Johnson, R., Miller, G.A., Ritter, W., Ruchkin, D.S., Rugg, M.D. and Taylor, M.J. (2000). Guidelines for using human event-related potentials to study cognition: recording standards and publication criteria. *Psychophysiology*, 37, 127–52.
- Polich, J. and Kok, A. (1995). Cognitive and biological determinants of P300: an integrative overview. *Biological Psychology*, 41, 103–46.
- Taylor, M.J. and Baldweg, T. (2002). Application of EEG, ERP and intracranial recordings to the investigation of cognitive functions in children. *Developmental Science*, 5, 3, 318–34.
- Zani, A. and Proverbio, A.M. (2002). *The Cognitive Electrophysiology of Mind and Brain*. Oxford: Academic Press.

Neuroimaging techniques

- Beaulieu, A. (2002). A space for measuring mind and brain: interdisciplinarity and digital tools in the development of brain mapping and functional imaging, 1980–1990. *Brain and Cognition*, 49, 13–33.
- Cabeza, R. and Nyberg, L. (1997). Imaging cognition: an empirical review of PET studies with normal subjects. *Journal of Cognitive Neuroscience*, 9, 1, 1–26.
- Cabeza, R. and Nyberg, L. (2000). Imaging cognition II: an empirical review of 275 PET and fMRI studies. *Journal of Cognitive Neuroscience*, 12, 1, 1–47.
- Huettel, S.A., Song, A.W. and McCarthy, G. (2004). *Functional Magnetic Resonance Imaging*. Oxford: Open University Press.
- Raichle, M.E. (1994). Images of the mind: studies with modern imaging techniques. *Annual Review of Psychology*, 45, 333–56.
- Senda, M., Kimura, Y. and Herscovitch, P. (2002). *Brain Imaging Using PET*. Oxford: Academic Press.
- Shallice, T. (2003). Functional imaging and neuropsychology findings: how can they be linked? *Neuroimage*, 20, S146–S154.
- Silbersweig, D. and Stern, E. (2001). *Functional Neuroimaging and Neuropsychology*. Hove, UK: Psychology Press.
- Toga, A.W. and Mazziotta, J.C. (2002). *Brain Mapping: The Methods*. Oxford: Academic Press.

Neural networks/connectionism

- Cohen, G., Johnstone, R.A. and Plunkett, K. (2002). *Exploring Cognition: Damaged Brains and Neural Networks*. Hove, UK: Psychology Press.

TMS

- Jahanshahi, M. and Rothwell, J. (2000). Transcranial magnetic stimulation studies of cognition: an emerging field. *Experimental Brain Research*, 13, 1–9.

2

The brain I: basic neurophysiology

- The nervous system and its two major divisions
- Cells in the nervous system
- The neuron
- The axon and myelination
- Different types of neuron
- Glial cells
 - Astrocytes (astroglia)
 - Oligodendrocytes (oligodendroglia)
 - Microglial cells
 - Schwann cells
- How neurons communicate I: the action potential
 - The membrane potential
 - Depolarization and hyperpolarization
 - How is the nerve impulse transmitted?
- How neurons communicate II: neurotransmission
 - The synapse
- What is a neurotransmitter?
- Types of neurotransmitter
 - Acetylcholine
 - Monoamines (biogenic amines)
 - Glutamate
 - γ -aminobutyric acid
 - Glycine
- How is neurotransmission stopped?
- Neurogeographical location of neurotransmitters
- The simplest of systems?
- Summary
- Recommended further reading

The nervous system and its major divisions

The greyish, soft, 1400 g jelly-like lump encased by the skull, together with the 1-cm-thick cord extending from the back of it, provides the fundamental basis for adult human behaviour. The brain is part of the nervous system (NS), the body's mass of interconnecting and interacting nervous tissue. The NS comprises two major parts: the central nervous system (CNS) and the peripheral nervous system (PNS). The CNS consists of nervous

tissue encased by the skull and the vertebral column, namely the brain and the spinal cord. The PNS consists of nervous tissue outside these bones: the cranial nerves, the spinal nerves and some sensory organ nerves. It contains two other distinct systems: the somatic nervous system, which receives sensory information from the muscles and skin and sends messages to skeletal muscles; and the autonomic nervous system (ANS), which innervates the body's glands and organs. The ANS has two branches: the sympathetic branch, which is responsible for arousal of the body via increased heart rate, release of adrenaline and suppression of the digestive system; and the parasympathetic branch, which has the opposite role of decreasing heart rate and facilitating the activity of the digestive system. Thus, one is energy-consuming, the other energy-conserving.

There is considerable interaction between the CNS and PNS. The PNS nerves can detect stimuli from outside the body and relay messages about these stimuli to the brain. Alternatively, the brain itself may send messages to the PNS. The cranial and spinal nerves of the PNS are considered in more detail in Chapter 3, as are the basic anatomy and structure of the brain. This chapter deals with the composition of the CNS and how the building blocks of the CNS behave and interact to allow behaviour to take place.

Cells in the nervous system

The CNS and PNS are made up of different types of cell. These cells are principally of two types: nerve cells, known as neurons, and supporting cells, known as glial cells. It has been estimated that between 100 billion and 1000 billion (1 000 000 000 000) neurons exist in the NS, although the exact number can never be known. Although this estimate is staggering enough, if you consider that neurons also communicate with other neurons, which in turn communicate with other neurons, you can quickly see how challenging it is to understand and study the functions of the brain. It is estimated that neurons make 13 trillion (13 000 000 000 000) connections with each other. The complexity of communication is further compounded by the ways in which neurons communicate. This is returned to later in the chapter.

Glial cells are so called because, as their name suggests, they are thought to be the glue that keeps neurons together. Although this description is not strictly accurate (glial cells do not actually stick neurons together), they are closely attached to neurons and serve the purpose of attending to the needs of these neurons. Whereas neurons perform the functions of the CNS, glial cells give essential practical and physical support to those functioning neurons. They can repair neuronal damage, can shape the neuron and can control how the neuron develops. There are more glial cells than neurons in the CNS. If you imagine the neurons as the kings and queens of the NS, then glial cells are the valets and ladies-in-waiting.

Neurons communicate with each other via electrical signals. This electrical signal or discharge is called a nerve impulse and allows neurons to communicate with each other along great distances. The impulses are fast (in the order of milliseconds) and can be sent between neurons of the CNS and the PNS or from neurons in the CNS and PNS to other neurons in the NS.

The neuron

We are born with all the neurons that we will get in life – hundreds of billions. It has been estimated that we lose 100 000 of these a day from birth. Unlike other cells in the body, neurons cannot regenerate when they die. In fact, the quest to find a way of regenerating neurons has been described as the ‘Holy Grail’ of neurobiology, and the discussion point below picks up the debate. From birth onwards, therefore, we encounter a massive loss of neurons. Based on the above estimate, for example, we would lose about 36.5 million neurons in one year. This does not necessarily mean that we will be worse off, having to struggle with a few billion neurons. In fact, the neuronal loss is necessary because redundant neurons are shed and connections between the existing efficient neurons are increased.

Discussion point: can neurons regenerate?

It was once a commonly held view that when neurons died, they died and were not replaced. When your skin is cut, it can heal within days; when your bones break, the fractured parts can fuse over time. When parts of the brain break, they are thought to be broken for good. Discovering the regeneration of neurons was regarded as the Holy Grail of neurobiology. However, research by Gerd Kempermann and his colleagues (Kempermann *et al.* 1997; Kempermann and Gage 1999) suggests that the Grail may be unearthed.

Skin and bone can heal because of ‘stem’ cells, whose job it is to regenerate cells. The brain was thought to be unable to repair itself because these stem cells were absent in the brain. What Kempermann and his team found was that one part of the mouse brain did appear to create new neurons – the hippocampus, a structure important for the formation of new memories. Because this research is still very new, however, little is known about these ‘new’ cells. How many cells are produced? Is the hippocampus the only area to produce them? Do they work like other neurons? Do they work at all? Are they created to replace other cells or to exist alongside them? What promotes their manufacture? Are they produced in humans to the same degree?

All these questions are exciting ones to answer, especially since the answers may one day lead to an advanced neuronal repair kit for some of our most serious neurological disorders, such as Alzheimer’s disease.

The neuron has a number of identifiable characteristics and physical features that are made visible by staining techniques. These techniques involve special dyes that highlight specific parts of the neuron. Some techniques highlight some parts of the neuron, while other techniques highlight other parts. The various parts sometimes appear as dark or coloured stains, contrasting with the light staining around them. The basic structure of the neuron can be seen in Figure 2.1.

A layer of lipids, called a membrane, covers the cell. This membrane exists to separate one neuron from another and contains substances that can (1) detect material outside the cell and (2) permit the exit of material from the cell. These substances actively transport material in and out of the cell. More importantly, the membrane has certain properties that enable it to carry nerve impulses, the electrical charge that enables neurons to communicate with each other.

Figure 2.1

The neuron and its processes (from Kandel, E.R. *et al.*, *Essentials of Neural Science and Behaviour*, © 1995, McGraw-Hill/Appleton & Large, reproduced with permission of The McGraw-Hill Companies)

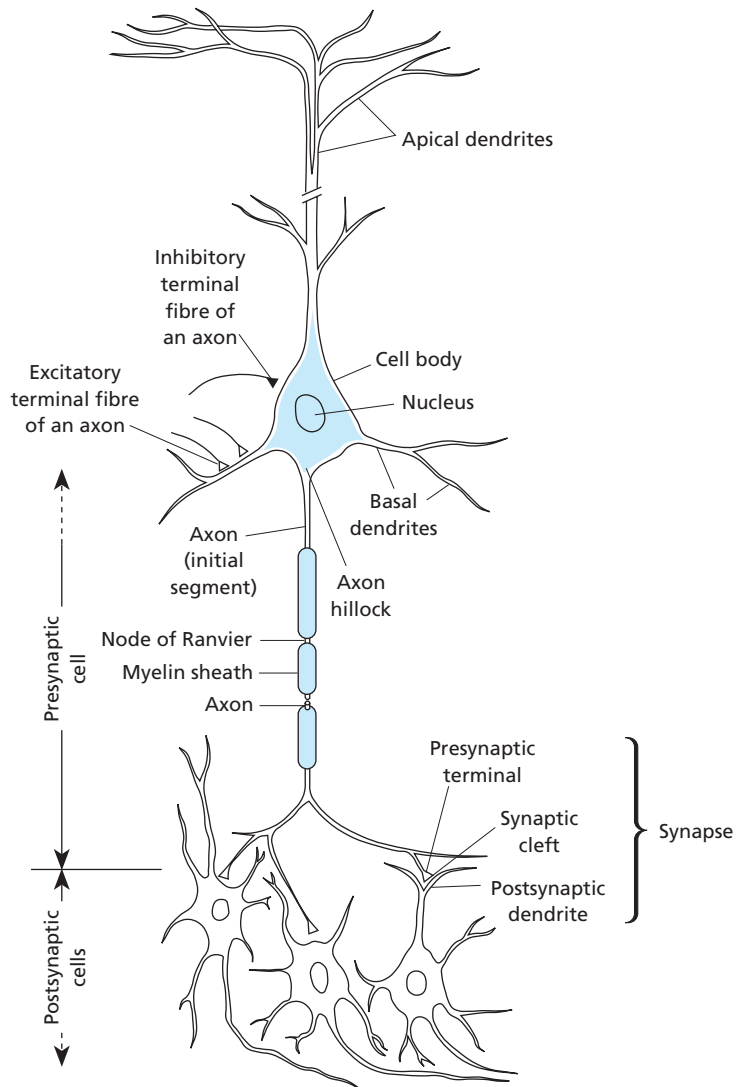

The centre of the neuron is called the cell body (or soma or perikaryon). Inside the cell body is a nucleus, and inside the nucleus is a nucleolus. The nucleus is large and makes the neuron clearly distinguishable from other NS cells. The neuron is surrounded by extracellular fluid, so called because it exists outside the cell (this is also known as interstitial fluid). Fluid inside the cell is called intracellular fluid. Several processes extend from the cell body that receive or send electrical signals. These are called dendrites and axons. There are usually several dendrites extending from the cell body, but only one axon. The dendrites might branch out to form a mass of dendritic processes. This is advantageous, because the role of the dendrites is to receive signals from other neurons. The dendrites might also have on them small spikes or spines, which increase their surface area and therefore allow more information to be received. It is the axon that is responsible for carrying the nerve impulse to other neurons. Axons can be either short or very long (the longest is just over 1 m). The advantage of having axons of differing lengths is that it permits them to communicate with neurons that are very far from or very near to the axon.

The axon leaves the cell body at a point called the axon hillock or initial segment. At the end of the axon there is a slight, knob-like enlargement called a terminal. This also has several other sobriquets, including bouton termineau (terminal button) and synaptic knob. The terminal is normally found close to the neuron receiving the axon's message. The point of contact between the terminal button and the other neuron is called the synapse. This is where information is sent from one neuron to another. In the PNS, terminal buttons may form synapses with muscle cells.

Communication at the synapse is made possible by the release of chemical substances known as neurotransmitters. These are stored in the synaptic vesicles of the terminal button. Although there are many neurotransmitters, they are fairly hard to identify. They are released by the nerve impulse, which prompts the neurotransmitter to leave the terminal button and enter the space between the button and the receiving neuron. This space is called the synaptic cleft and is approximately 20 nm wide (about 0.00002 mm). Because neurotransmitters are released by the terminal button and the proteins necessary for transmitting these chemicals are stored there, the membrane of the neuron facing the cleft (the terminal button) is thicker than that of the receiving neuron. This thicker membrane is called the presynaptic membrane because it is situated before the cleft (hence, presynaptic). The surface of the cell contacted is called the postsynaptic membrane. Similarly, those neurons situated before the cleft are called presynaptic neurons, whereas those receiving the neurotransmitter are called postsynaptic neurons. Synapses can occur almost anywhere on the neuron. For example, there can be synapses on the cell body (axosomatic synapses), the dendrites (axodendritic synapses) and on the axon itself (axoaxonic synapses), as seen in Figure 2.2.

There are hundreds, possibly thousands, of synapses on each neuron. The number is so large that the Nobel Prize-winning neurobiologist Gerald Edleman has estimated that it would take 32 million years to count the number of synapses in the CNS.

Figure 2.2

Examples of axonal synapses (from Kandel, E.R. *et al.*, *Essentials of Neural Science and Behaviour*, © 1995, McGraw-Hill/Appleton & Large, reproduced with permission of The McGraw-Hill Companies)

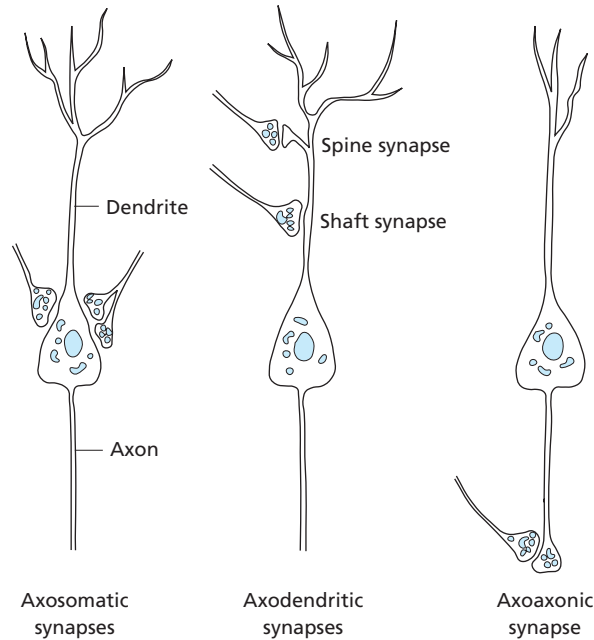

The axon and myelination

The axon is one of the most important processes extending from the cell body. It is covered by a membrane called the axonal membrane (or axolemma). Almost all axons in the CNS are surrounded by a myelin sheath. This sheath is made up of a number of layers (lamellae) of lipids (fats) and proteins called myelin, which insulates the axon from its surroundings and from other neurons. The sheath contains about 80 percent lipid and 20 percent protein. This insulation is advantageous because it helps the rapid conduction of nerve impulses. It does this by reducing the loss of the flow of current from the axon to the surrounding fluid. Axons covered in myelin are called myelinated axons; those not covered are called unmyelinated axons. The thicker the sheath the more rapid the speed of signal conduction. In some diseases, axons can become demyelinated (e.g. in multiple sclerosis). As a result, impulse conduction is either slowed down considerably or is stopped completely. If the disease progresses, the axon itself (as well as its myelin sheath) may degenerate.

The myelin sheath is cylindrical in shape, gives off a whitish appearance (because of the fat content) and is produced by a specific type of glial cell. At intervals, however, the axonal membrane is unmyelinated, exposing it to the surrounding fluid. These unmyelinated points of the axon are called the nodes of Ranvier and separate the segments of myelinated axon (the nodes are about 1–2 mm in length; the myelinated segment is about 1 mm). These nodes assist in the speed of conduction by making the nerve impulse jump from one node to the next.

Figure 2.3

(a) An oligodendrocyte; (b) a Schwann cell (from Kandel, E.R. *et al.*, *Essentials of Neural Science and Behaviour*, © 1995, McGraw-Hill/Appleton & Large, reproduced with permission of The McGraw-Hill Companies)

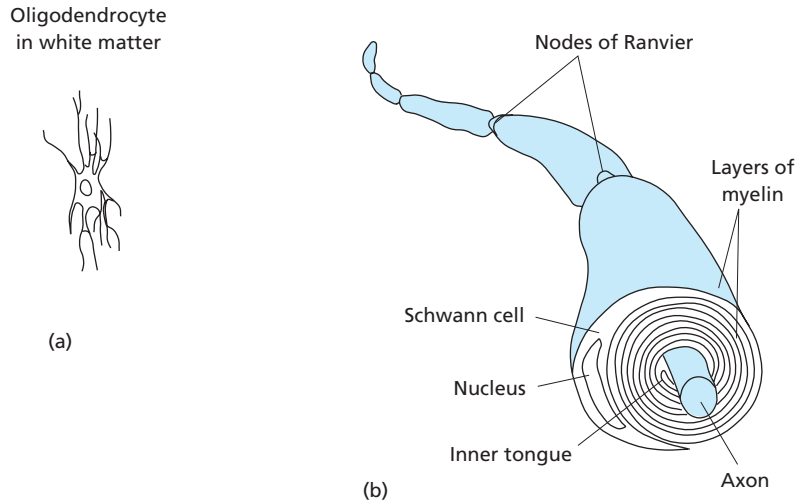

In the CNS, myelin is made from a type of glial cell called oligodendrocytes (or oligodendroglia). In the PNS, the myelin is produced by Schwann cells. Both of these cells are illustrated in Figure 2.3. Myelination is an important process in the NS, since it is closely related to functional maturation. It begins before birth and continues until the age of 2, possibly ending during adolescence or young adulthood.

Different types of neuron

There are different types of neuron in the CNS, which can be distinguished either by the length of their processes or by the number of processes extending from them. Some of these are illustrated in Figure 2.4. For example, projection neurons send impulses via long axons to other neurons across long distances (these are also known as Golgi type 1 cells). The axons of projection neurons may also 'project' axon collaterals as they make their way to their target site. Collaterals – processes extending from the axon – might therefore terminate earlier and in different places from the parent axon.

A second type of neuron is called an interneuron (also called a Golgi type 2 cell). Interneurons have short processes that occur close to the cell body. One could argue that every neuron is an interneuron, because every neuron sends signals to and receives signals from many other neurons and can therefore mediate the activity of other neurons. However, the term 'interneuron' is reserved for those neurons that communicate with only one group of neurons. Neurons are also described according to the number of axons and dendrites they send out, as seen in Figure 2.5.

The cell bodies of CNS neurons are often seen to congregate in groups. When this happens, the cell bodies form nuclei (or, when occurring in the PNS, ganglia). Groups of axons might leave these nuclei in close, near-parallel formation. When groups of axons extend from cell bodies in this fashion, they form a tract (in the PNS, they form a nerve). The axonal tracts are sometimes accompanied by smaller, parallel collections of axons,

Figure 2.4

Types of neuron and interneuron (from Kandel, E.R. *et al.*, *Essentials of Neural Science and Behaviour*, © 1995, McGraw-Hill/Appleton & Large, reproduced with permission of The McGraw-Hill Companies)

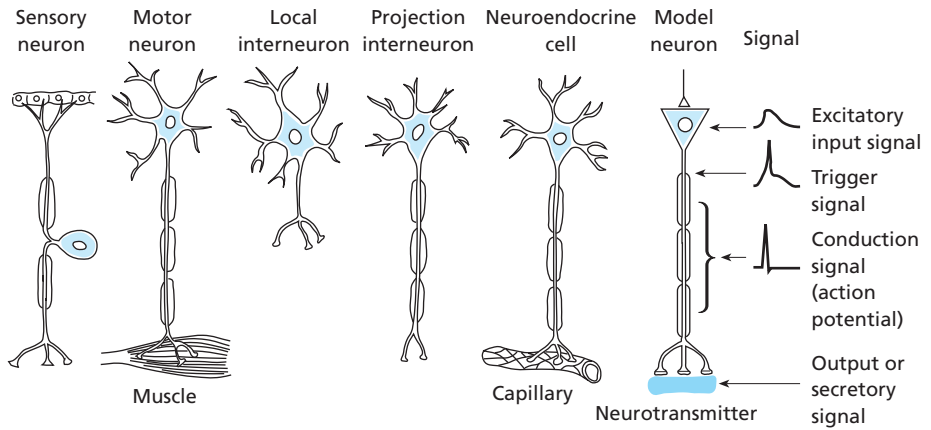
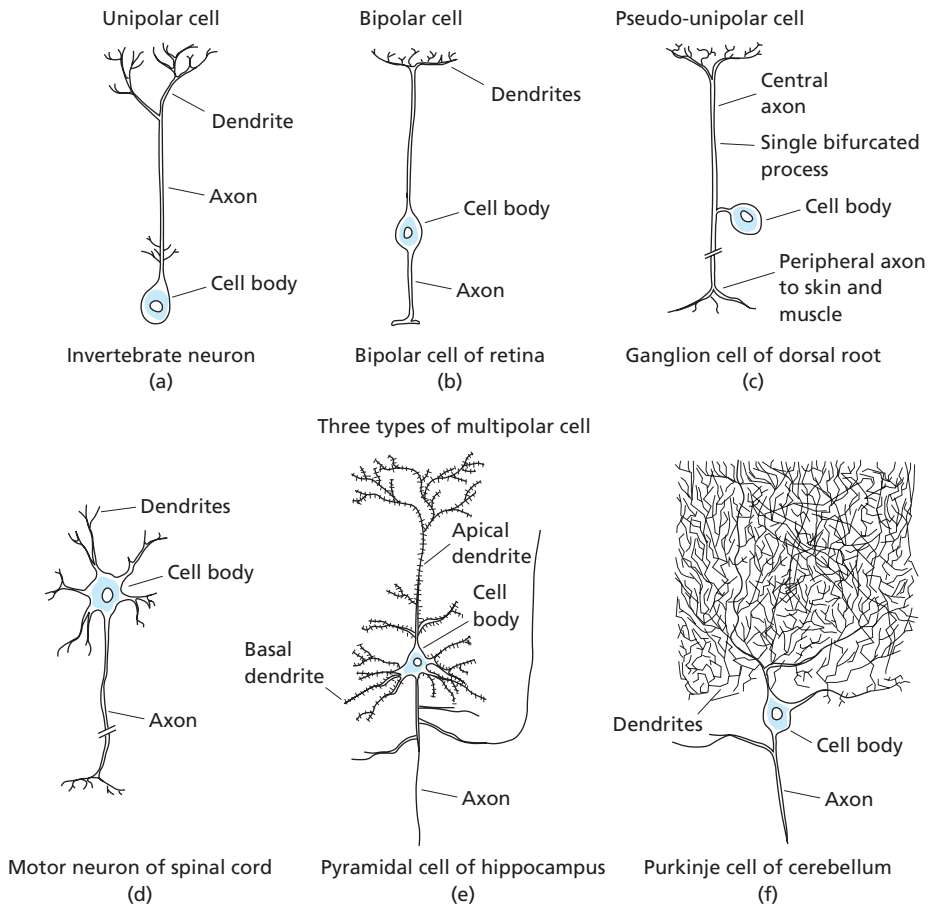

Figure 2.5

Types of cell: (a) unipolar cell; (b) bipolar cell; (c) pseudo-unipolar cell; (d), (e) and (f) three types of multipolar cell (from Kandel, E.R. *et al.*, *Essentials of Neural Science and Behaviour*, © 1995, McGraw-Hill/Appleton & Large, reproduced with permission of The McGraw-Hill Companies)



which often branch off before the tracts terminate. These smaller bundles terminate on other neurons. However, it is the tract that provides the greatest route for the nerve impulse. These tracts, because of their myelinated axons, give off a whitish colour. Tissue that contains large numbers of myelinated axons is therefore called white matter; tissue that contains primarily cell bodies and dendrites (as well as some axons) is called grey matter (because it looks grey). Despite the complexity of the system (consider again the number of connections and interconnections possible), there is organization in this complexity, as we see below.

Glial cells

Although they do not strictly glue parts of the nervous system together, glial or supporting cells do help to bind neurons and their processes together. Although around 90 percent of the cells in the brain are glial cells, these have until recently been thought to perform quite mundane functions such as serving the needs of neurons. However, it now appears that glial cells may determine the number of synapses generated in the brain (Ullian *et al.* 2001).

The finding followed another extraordinary finding: that synapses of neurons grown with astrocytes – a type of glial cell – were ten times more active than those grown without. The mere proximity of glial cells to neurons made the neurons more responsive. Neurons exposed to glial cells can form seven times as many synapses as those that are not exposed.

There are three main types of glial cell (there are others), all of which serve a distinct function and have a distinct structure.

Astrocytes (astroglia)

Astrocytes are the most common type of glial cell in fact of any type of brain cell. They are so-called because of their star shape, and their function is to provide physical support for cells, as seen in Figure 2.6. They are also responsible for phagocytosis, the process whereby dead cells are engulfed and digested. Because neurons die or are killed, it would be disadvantageous to have waste material and debris of this kind floating around the CNS, and astrocytes ensure that this debris is vacuumed. Astrocytes also produce scar tissue when the CNS is damaged or injured. They perform all support functions by wrapping the arms of their stars around various processes.

Astrocytes can exchange substances with neurons, remove or break down the neurotransmitters released into the synaptic gap, thereby preventing too much neurotransmitter building up in the extracellular fluid, and regulate the concentration of potassium ions in the extracellular fluid. As explained in the section on neurotransmission below, the excitability of neurons depends on the concentration of potassium. If a neuron is ‘over-activated’, too much potassium can be left in the extracellular fluid. Astrocytes help in removing this excess substance.

Figure 2.6

An astrocyte (from Kandel, E.R. *et al.*, *Essentials of Neural Science and Behaviour*, © 1995, McGraw-Hill/Appleton & Large, reproduced with permission of The McGraw-Hill Companies)

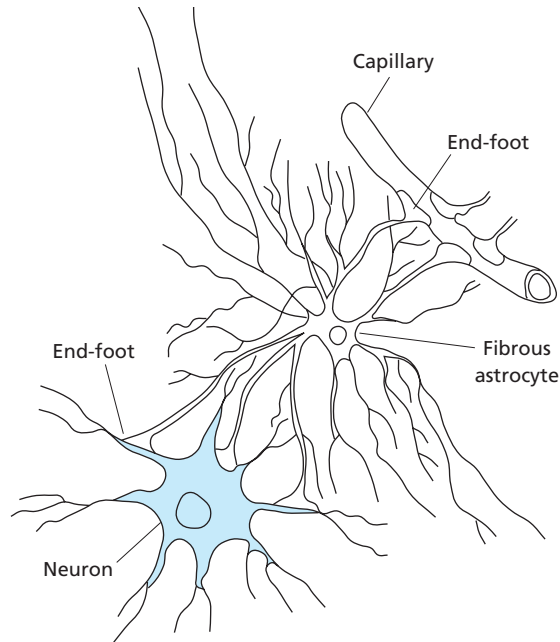

Oligodendrocytes (oligodendroglia)

Oligodendroglia are another type of glial cell that supports the CNS. Their principal function is the production of myelin. Sometimes oligodendroglia are found very near the cell body. When this occurs, they are called satellite cells.

Microglial cells

Between 5 and 20 percent of glial cells are microglia, so called because they are small; they are evenly distributed throughout the CNS. Microglia have phagocytic properties and are thought to be activated in response to some insult to the brain such as inflammation, tumour or infection. They are sometimes called 'scavenger cells'. For example, they are thought to destroy invading organisms, remove dangerous material and promote tissue repair by secreting growth factor (Kreutzberg 1996). Their small size makes them difficult to identify; they appear to have no clear-cut structural features. In fact, according to some authors, they may even be a variety of oligodendrocyte (Brodal 1992).

Schwann cells

As we have seen from the section on myelination, the PNS has its own type of supporting cell, the Schwann cell, to help to support and insulate that system's processes. Schwann cells also give physical guidance to sprouting or damaged PNS axons. For example, when axons die, Schwann cells help in digesting the dead material and in arranging themselves cylindrically around the axon to guide its regrowth (unlike neurons, axons can regrow).

There are Schwann cells that myelinate and others that do not. The non-myelinating Schwann cells are called terminal Schwann cells. There is some evidence to suggest that these cells maintain and repair neurons at neuromuscular synapses by sensing changes at the synapse and responding to them (Son *et al.* 1996).

How neurons communicate I: the action potential

Neurons communicate with each other by sending electrical impulses called action potentials. Potential refers to source of electrical activity – the neuron's method of communication is thus electrical. This communication depends on the neuron's excitability – its capacity to react to a stimulus with an electrical discharge (or current or impulse – all of these words refer to the same thing).

The action potential is produced by charged particles called ions that pass through the cell membrane. The extracellular and intracellular fluid both contain ions. These ions are either positively charged (cations) or negatively charged (anions). The familiar phrase 'opposites attract' has its origin in electrolyte chemistry, because while similarly charged ions repel, differently charged ions attract. The force produced by this repulsion and attraction is called electrostatic pressure. There are many different ions unevenly distributed inside and outside the cell membrane (intracellularly and extracellularly). It is this distribution that gives the membrane its electrical potential and is therefore called the membrane potential. The membrane has an electrical charge, because there are positive and negative ions both inside and outside the cell membrane.

The membrane is selectively permeable to ions. That is, it allows only certain ions in. Perhaps the most significant ions are Na (sodium), K^+ (potassium), Ca^{2+} (calcium) and Cl^- (chloride). Potassium, sodium and chloride ions are found in extracellular and intracellular fluid, although there is more potassium in intracellular fluid and more sodium and chloride in extracellular fluid. Chloride is the more prominent extracellular anion. The type of channel opening that is governed by neurotransmitters is called transmitter- or ligand-gated. Some channels are regulated by the magnitude of the membrane potential. These channels are called voltage-gated, and it is these that are responsible for producing the action potential. The permeability of the membrane, i.e. its ability to allow potassium to enter or exit, is dependent not only on how many channels there are, how they are distributed and how much they open but also on the concentration gradient of the ion. The steeper this is, the greater the flow of ions.

The membrane potential

If the inside of the membrane is negative relative to the outside, positive ions will be attracted inside. As a result, negative ions will be forced out because, as you will recall, similarly charged ions repel. The degree of attraction or repulsion is determined by the membrane potential. For most neurons, the charge across this membrane is about 60–70 millivolts (mV) when it receives no stimulation. This charge is called the resting potential. Because there are more negative ions inside the cell, this resting potential has been arbitrarily defined as negative, i.e. as –60/70 mV.

The potential is produced by the membrane's selective permeability to ions and the different concentrations of ions inside and outside the cell. The unequal distribution of ions

is maintained by 'pumps' in the cell membrane. Potassium, for example, flows through the membrane quite easily when the cell is at rest, whereas sodium passes through with difficulty. Thus the expulsion of potassium results in the inside of the cell losing positive ions, producing a negative charge on the inside. Potassium does not leave the inside of the cell endlessly, because at a certain point the membrane will force potassium to flow back into the cell. At 70 mV, the strengths of the outward and inward flows of potassium are similar. This represents potassium's equilibrium potential. The resting potential is slightly lower than potassium's equilibrium potential because the membrane is also permeable (but only slightly) to positively charged sodium ions. Thus, as potassium ions flow out, a small number of sodium ions enter the membrane, making the internal negative charge slightly less negative. The mechanism regulating the influx and efflux of sodium and potassium is the sodium–potassium pump. This forces out sodium ions in exchange for potassium ions, usually in the ratio of 3:2, that is for every three sodium ions expelled, two potassium ions are pushed in.

Depolarization and hyperpolarization

When sodium channels are opened, the cell becomes more permeable to sodium, and the resting potential becomes more like the equilibrium potential for sodium (55 mV). The increased permeability and influx of sodium constitute what is called depolarization: the positive ions make the membrane potential less negative. If this continues and positive ions continue to flow into the cell, the intracellular charge reverses from negative to positive. Eventually, the resting potential is reached but is first overshoot. When this happens, the membrane is described as hyperpolarized and the process is called hyperpolarization. The time taken from depolarization to hyperpolarization is approximately 2–3 milliseconds (ms). This is the action potential: the depolarization and hyperpolarization of the cell membrane produced by an increase in the cell's permeability to sodium ions. To allow an action potential to occur, the membrane must reach the threshold of excitation. That is, it must be excited to a certain degree before an action potential is fired. The number of action potentials can reach 100 per second. Although this process might seem to require a large exchange of ions, the actual quantity of ions flowing in and out of the cell is small (one for every 3000 ions in the case of potassium, for example; see Figure 2.7).

The strength of an action potential is the same regardless of the strength of the stimulation. So, although a weak and a strong stimulus can both trigger an action potential, the strength of the action potential is the same. However, there are factors that influence the generation of the action potential. These are the frequency and the pattern of the stimulation. Sometimes one stimulus is not enough to precipitate an action potential: several bouts of stimulation are needed.

One ion so far unmentioned is calcium. Although this appears not to be as important as sodium and potassium in causing the action potential, calcium plays an important role in the extracellular regulation of the excitability of the cell membrane. The membrane does contain voltage-gated calcium channels. Calcium enters the cell during the action potential (actually, through sodium as well as calcium channels). Perhaps its most important role is intracellular. Its presence in the terminal buttons of axons is necessary for the release of neurotransmitters.

In the period following the action potential there is a period of relative calm before another action potential is fired. This resting state is called the cell's refractory period.

Figure 2.7

The flow of potassium across a cell membrane (from Kandel, E.R. *et al.*, *Essentials of Neural Science and Behaviour*, © 1995, McGraw-Hill/Appleton & Large, reproduced with permission of The McGraw-Hill Companies)

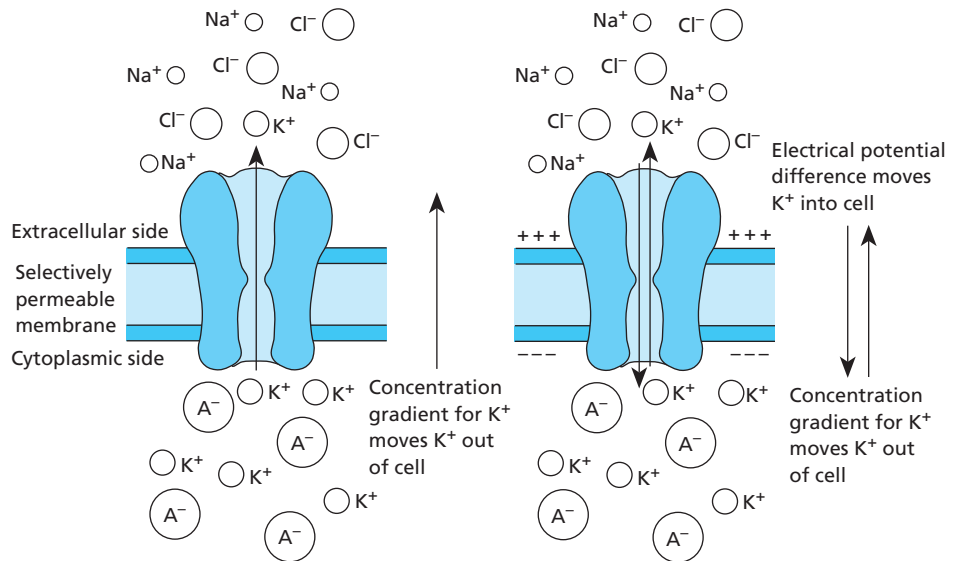

This state has been classed into two phases: the absolute refractory period, where a cell is incapable of producing another action potential regardless of the strength or frequency of stimulation; and the relative refractory period, where stronger than normal depolarization is necessary.

How is the nerve impulse transmitted?

Although the axon can send an electrical current, it does so in a way quite unlike copper wire. It can lose particles and has high internal resistance: any normal electrical signal would soon fizzle out and die in such circumstances. The reason why the action potential does not die is that it is repropagated (or recharged) as it makes its way along the axon.

The course of the action potential is different depending on whether the axon is myelinated or unmyelinated. In unmyelinated axons, the impulse leaves the axon hillock, where depolarization occurs and where the action potential is triggered, and goes through repolarization. In myelinated axons, the impulse still continues for a short distance but is regenerated at the nodes of Ranvier, the unmyelinated parts of myelinated axons, which are directly exposed to the extracellular fluid. The passage of the impulse from the axon hillock to the first node is electrotonic (passive). This node becomes depolarized, and another action potential occurs. The potential occurs because voltage-gated sodium channels are opened here. The electrical message is thus passed along the axon by being regenerated at each node. Whereas the passage of the action potential in unmyelinated axons is smooth, the course of the action potential in myelinated axons is slightly more jumpy because it is repropagated at each node. At each node, therefore, there is a slight delay before the impulse moves on, because the membrane has to open channels and allow the flow of ions in and out.

How neurons communicate II: neurotransmission

The synapse

To recap: when an action potential is sent down the axon, depolarization occurs at the terminal button. This is not the end of the communication process. When depolarization occurs at the terminal button, calcium channels open, allowing this ion to enter the cell. The increased permeability to calcium and its presence in the cell is responsible for the secretion of a neurotransmitter from the vesicles. The neurotransmitter is released into the synaptic gap by a process called exocytosis. This means that the transmitter-containing vesicle moves up to the cell membrane of the presynaptic terminal button, pushes up against it and fuses with it. When this occurs, the vesicle releases the neurotransmitter, which moves into the extracellular fluid of the synaptic gap, where it binds to the postsynaptic, or receiving, terminal button of another neuron. A further stage of communication is then reached. Sometimes the neurotransmitter is released in small packets called quanta.

The neurotransmitter can alter the membrane potential and alter its permeability. Because of these effects, the neurotransmitter produces a synaptic potential that is slower than the action potential. If this potential is a depolarizing one, then the postsynaptic neuron may fire an action potential. When this happens, the effect of the neurotransmitter is excitatory: it excites a cell into producing an action potential and results from sodium and calcium ions going in and potassium ions being pushed out. This type of potential is called an excitatory postsynaptic potential (EPSP; see Figure 2.8).

The amount of neurotransmitter released may be dependent on the amount of calcium entering the presynaptic neuron following depolarization. So an increase in the amount of calcium entering the neuron becomes associated with larger amounts of neurotransmitter being released. Conversely, small amounts of calcium entering the neuron will be associated with little or perhaps no release of neurotransmitter. However, sometimes this relationship is not obvious: increased synaptic transmission may not follow increased inflow of calcium. What is more, decreased calcium is also found to accompany increases in neurotransmitter release. When this occurs, the release of neurotransmitter is said to be calcium-independent (Piccolino and Pignatelli 1996). The mechanism for this is unknown.

Figure 2.8

The effects of excitation and inhibition on a neuron: (a) excitation; (b) inhibition; (c) excitation and inhibition (from Kandel, E.R. *et al.*, *Essentials of Neural Science and Behaviour*, © 1995, McGraw-Hill/Appleton & Large, reproduced with permission of The McGraw-Hill Companies)

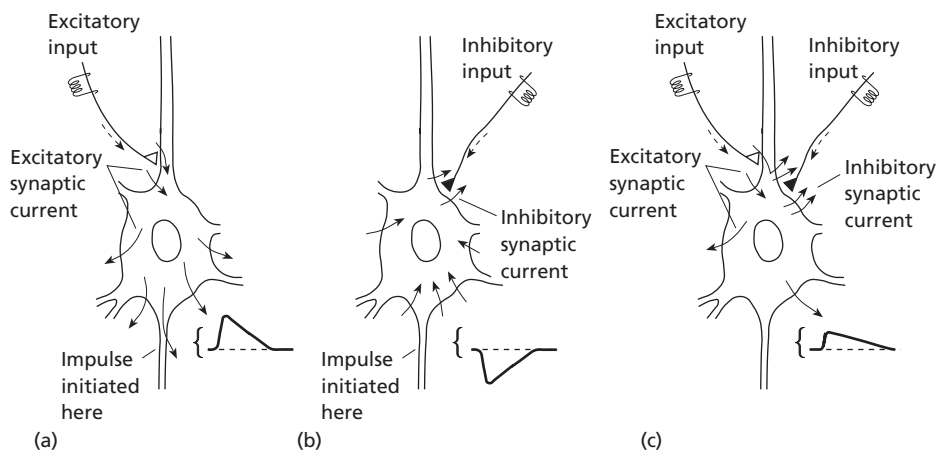

It takes more than one EPSP to produce an action potential in the receiving cell. Normally, repeated stimulation (many EPSPs) are needed before this can happen. There is a certain threshold value that these potentials must reach before the depolarization triggers an action potential. The process of repeated stimulation that produces an action potential is called summation because the effect of one EPSP is added to the next, which is added to the next and so on until the threshold for depolarization is reached. This form of frequent repeated stimulation is called temporal summation. The apparatus employed for producing an action potential is illustrated by Figure 2.9.

The opposite effect might happen at the postsynaptic button and the membrane could become hyperpolarized. This actually prevents the firing of an action potential by the postsynaptic button. When this occurs, the neurotransmitter's effect is called inhibitory and the potential produced by these transmitters is called the inhibitory postsynaptic potential (IPSP). Here, potassium ions leave the membrane and negative chloride ions might be pumped in, making the inside of the cell negatively charged. The point of inhibition is that it prevents the neuron becoming overstimulated, as overstimulation could result in cell damage or death. Epileptic seizures result from an uncontrolled firing of impulses, which is why many drugs to combat epilepsy help the inhibition of impulses. Because of the two different effects that neurotransmitters have, they are referred to as either excitatory or inhibitory neurotransmitters.

Figure 2.9

Example of communication between cells and other parts of the body (from Kandel, E.R. *et al.*, *Essentials of Neural Science and Behaviour*, © 1995, McGraw-Hill/Appleton & Large, reproduced with permission of The McGraw-Hill Companies)

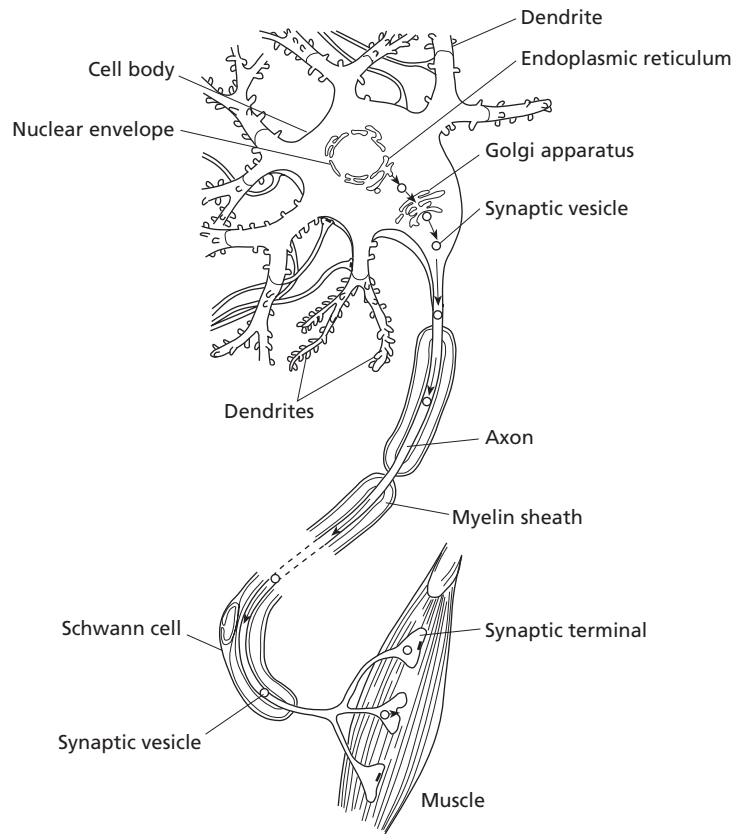

What is a neurotransmitter?

So far we have described the effects of chemicals released by presynaptic buttons at the synapse on the activity of postsynaptic neurons. These chemicals send a signal to the postsynaptic button and can be inhibitory or excitatory. These are the properties of the neurotransmitter. Most of the more prominent neurotransmitters are protein-based. Neurotransmitters can be made up of small or large protein molecules. All small-molecule neurotransmitters except acetylcholine are amino acids or a type of amino acid called an amine. Larger molecules are made up of peptides (proteins that are made up of a small number of amino acids). Because of this they are called neuropeptides; their function is not as clear as that of the small-molecule transmitters. There are probably about 30–40 identifiable neuropeptides in the CNS.

The function of all neurotransmitters is not clear, because the type of effect they produce depends on the type of receptor they bind to or communicate with. Neurotransmitters are made in the cell body and stored in the vesicles, as we saw in the section above. Usually, a terminal button contains one neurotransmitter and one or more neuropeptide. This complicates any understanding of the specific effects of each type of transmitter, because the transmitters are released together.

Neurotransmitters are synthesized in the terminal button by enzymes travelling from the cell body. Neuropeptides, on the other hand, are synthesized in the cell body and travel down to the terminal button. The travelling nature of the peptides means that they are more prone than neurotransmitters to blockage. Blocked axons can prevent a neuropeptide from moving smoothly to the cell body; this problem does not arise for neurotransmitters.

Some of the known major neurotransmitters and the functions they appear to perform are described below.

Types of neurotransmitter

Acetylcholine

Acetylcholine is a small-molecule neurotransmitter that is synthesized by binding choline to acetyl coenzyme A. The binding is produced by the enzyme choline acetyltransferase (ChAT). Neurons that contain acetylcholine or ChAT are called cholinergic neurons. These are found mostly in the motor system, especially in brainstem and spinal cord motor neurons that innervate muscles of the skeleton. The chemical binds to acetylcholine receptors. This eventually produces an action potential that results in muscle contraction. Acetylcholine receptors are also known as nicotinic receptors because nicotine seems to produce the same effects on muscles as acetylcholine does. The receptors can be blocked, which sometimes results in motor impairment. Curare is one acetylcholine blocker; another is atropine.

Monoamines (biogenic amines)

The monoamines are also small-molecule neurotransmitters and include noradrenaline (also known as norepinephrine), adrenaline (also known as epinephrine), dopamine, serotonin (also known as 5-HT or 5-hydroxytryptamine) and histamine. The first three are collectively known as the catecholamines and are synthesized from tyrosine, an amino acid. The last two are also synthesized from amino acids, in this case tryptophan and histidine, respectively. The catecholamines appear to be involved in most of the important behaviour, such as movement, mood and cognition.

The effects that these neurotransmitters have on postsynaptic neurons is complex. For example, each neurotransmitter has different types of receptor. For dopamine, there are so-called D1 and D2 receptors, which are different in function and distribution. Noradrenaline and adrenaline have alpha and beta receptors, which sometimes produce completely different effects. Serotonin has several types of receptor. All of this receptor divergence means that a monoamine can both inhibit and excite depending on the type of receptor it contacts.

Glutamate

Glutamate is an excitatory amino acid and is served by three receptor types. The first two, known as kainate (K) and quisqualate (Q) receptors, are responsible for fast depolarization, the third is not. Glutamate-containing presynaptic neurons may control the release of the neurotransmitter from specific release sites (Sanchez-Prieto *et al.* 1996). They may do this via presynaptic autoreceptors, which give feedback about the action of previously released neurotransmitter.

γ -aminobutyric acid

γ -aminobutyric acid (or GABA) is the most common of the inhibitory amino acid CNS neurotransmitters. This transmitter produces hyperpolarization by opening either chloride channels or potassium channels. GABA has two types of receptor: GABA_A and GABA_B. The A receptor is responsible for inhibition presynaptically and mediates the membrane permeability of chloride; the B receptor mediates potassium permeability. Drugs such as benzodiazepines and barbiturates (so-called anti-anxiety drugs) bind to these receptor sites and enhance the effects of GABA, either by increasing the frequency of opening of chloride channels or by prolonging this opening when it occurs. More information about the effects of these drugs can be found in Chapter 12.

Glycine

Glycine is another inhibiting neurotransmitter found in the brainstem and interneurons of the spinal cord. Its primary function appears to be the inhibition of motor neurons: for example, the glycine-receptor blocker, strychnine, causes muscle spasms.

How is neurotransmission stopped?

It is inadvisable for neurotransmission to continue ceaselessly for many of the reasons given for preventing perpetual excitatory or inhibitory stimulation. In fact, neurotransmission does have a set time and stops depending on the type of neurotransmitter and receptor it contacts. Furthermore, the surplus neurotransmitter in the extracellular fluid that does not bind to the postsynaptic membrane is cleaned away by reuptake mechanisms. That is, the neurotransmitter is taken back into the presynaptic button and either stored and reused or broken down. Some neurotransmitters, such as acetylcholine, also have enzymes in the synaptic gap that can break them down. However, some chemicals such as cocaine and amphetamine, prevent reuptake, thus potentiating the excitatory effect of the neurotransmitter.

Neurogeographical location of neurotransmitters

Certain neurotransmitters are found in groups of neurons (nuclei). These nuclei are distinct from each other in that some contain, for example, dopamine, while others contain adrenaline. Noradrenaline is most common in nuclei found in a part of the brainstem called the reticular formation (see Chapter 3). These nuclei form a distinct neuronal group called the nucleus locus coeruleus. However, dopamine is found mainly in large nuclei in the mesencephalon and substantia nigra (see Chapter 3). Serotonin is found predominantly in the raphe nuclei in the brainstem, whereas acetylcholine is found in the brainstem and parts of the forebrain, specifically in the nucleus basalis of Meynert. In later chapters, especially those on emotion, dementia and motor system disorders and memory, we see how drugs act on the NS to produce changes in these 'neurotransmitter systems'.

The simplest of systems?

Until now we have considered the neuron and its effects on other neurons as if one neuron communicates only with other single neurons. In the NS this never happens: groups of neurons exert effects on other groups of neurons. The simplest pathway – an axon from one neuron sending an action potential to only one other neuron – does not exist in the CNS. Usually, neurons contact many other neurons, because their axons have collaterals that communicate with other neurons before the end of the axon reaches its destination. Thus there is a divergence of neuronal connections. Conversely, there could be a convergence of connections with several neurons contacting one neuron. This neuron could be the end target for the other neurons. There is also a strong presence of parallel pathways: two neurons send an action potential in parallel to another neuron. There are also intricate feedback loops. For example, a neuron could fire an action potential received by a neuron, which in turn sends a message back to the sender. This return message can tell the neuron whether its effect was weak or strong. Sometimes a group of neurons do not send the same message. However, provided that enough do, the probability of having the

desired effect on the postsynaptic neuron is increased. Because of these connections and interconnections, you will not be surprised to hear that the NS is never inactive in a living being with a nervous system.

Summary

All behaviour depends on the normal, active functioning of the nervous system (NS). The NS comprises two major systems: the central nervous system (CNS) and the peripheral nervous system (PNS). The CNS represents the brain and the spinal cord; the PNS represents nervous tissue that lies outside the skull and vertebral column. Nervous tissue is made up of neurons (nerve cells) and supporting or glial cells (glia). There are slightly more glia than neurons. Axons are the processes that send electrical messages to other neurons. Neurons communicate via electrical signals or impulses called action potentials. These potentials are produced by the activity of electrically charged particles called ions. The most important ions are sodium, potassium, calcium and chloride. Neurotransmitters are released from the terminal into the space between the sending (presynaptic) and receiving (postsynaptic) neurons. This space is called the synaptic gap. Neurotransmitters can excite or inhibit postsynaptic neurons. The most well known and best described are acetylcholine (important for muscle movement), the monoamines noradrenaline (norepinephrine), adrenaline (epinephrine), dopamine, serotonin (5-hydroxytryptamine or 5-HT) and histamine, glutamate, γ -aminobutyric acid and glycine.

Recommended further reading

General neurotransmission and neurophysiology

- Brodal, P. (1998). *The Central Nervous System: Structure and Function* (2nd edition). New York: Oxford University Press.
- Kandel, E.R., Schwartz, J.H. and Jessell, T.M. (1995). *Essentials of Neural Science and Behaviour*. New Jersey: Prentice Hall International.

Neurons and synapses

- Atwood, H.L. and Lnenicka, G.A. (1986). Structure and function in synapses: emerging correlations. *Trends in Neurosciences*, 9, 248–50.
- Levitan, I.B. and Kaczmarek, L.K. (1991). *The Neuron*. Oxford: Oxford University Press.
- Shepard, G.M. (1998). *The Synaptic Organisation of the Brain*. Oxford: Oxford University Press.

Neurotransmitters and neurotransmission

- Bellen, H. (1999). *Neurotransmitter Release*. Oxford: Oxford University Press.
- Katz, P. (1999). *Beyond Neurotransmission*. Oxford: Oxford University Press.
- Kelly, R.B. (1993). Storage and release of neurotransmitters. *Cell 72/Neuron10*, 43–53.
- Valenstein, E.S. (2002). The discovery of chemical neurotransmitters. *Brain and Cognition*, 49, 73–95.

3

The brain II: basic neuroanatomy

- Introduction: coming to terms with terms
- Positional terms
- Development of the central nervous system
- Spinal cord
- Spinal nerves
- Brainstem
 - Medulla oblongata
 - Pons
 - Mesencephalon
 - Diencephalon
- Cerebellum
- Cerebral cortex
 - Fissures and sulci
 - Lobes of the brain
 - Basal ganglia
 - Limbic system
- Organization of the cerebral cortex
 - The six layers of the cortex
 - Columns of the cortex
 - Connections between brain regions
- Cranial nerves
- Covering the brain
- Ventricular system
- Arteries of the brain
- Malfunctions of the brain
 - Closed-head injury
 - Cerebral oedema
 - Infarction
 - Ischaemia
 - Thrombosis
 - Cerebrovascular accident/stroke
 - Haemorrhage (subarachnoid)
 - Tumour (intracranial)
 - Anoxia
 - Encephalopathy
 - Encephalitis
 - Hydrocephalus
 - Headache
- Sensory and motor systems
 - Visual system
 - Auditory system

Somatosensory system

Gustatory system

Olfactory system

Motor system

Summary

Recommended further reading

Introduction: coming to terms with terms

Opening any textbook on neuroanatomy can seem like encountering a new language. Strange, alien, polysyllabic terminology tends to mingle with convoluted and equally alien language. In fact, reading neuroanatomy is actually like reading many languages, since many of the terms used to describe function or structure have Greek, French or Latin roots or may be a combination of these and other languages. Polyglotism is not essential for understanding neuroanatomy, but it is an advantage. This is what appears most daunting to a student of neuropsychology: coming to terms with terms.

Aside from the terms in different languages, the student of neuropsychology will also encounter more than one term referring to the same function or structure. So, for example, area 17, the striate cortex and the primary visual cortex all refer to the same area (the part at the back of the brain where visual information from the retina is processed). Area 44 is also known as Broca's area, the anterior language area or the frontal operculum. The effect of damage to this part of the brain is an inability to produce speech. This is known as Broca's aphasia. It is also known as motor aphasia, non-fluent aphasia, production aphasia or expressive aphasia. Damage to Wernicke's area (or the posterior language area) produces an inability to comprehend language. This is called Wernicke's aphasia, sensory aphasia or receptive aphasia. Throughout this book, alternative names are often given for structures when these structures are first encountered in the text but, for clarity's sake, only one term is used thereafter.

Positional terms

There are terms used in neuropsychology that describe the position of parts of the nervous system. A list of these appears in Table 3.1, and the most widely used are defined here.

The direction of structures is described according to a neuraxis, an imaginary line that can be drawn from the spinal cord to the brain. Its parts are referred to as rostral, caudal, dorsal or ventral, as seen in Figure 3.1. Rostral literally means towards the beak and normally refers to the anterior or front end of the region. Caudal (literally, towards the tail) refers to a region posterior to or towards the back end of other regions. The top of the head or back is referred to as the dorsal surface; the front end of the body (the part facing the ground) is referred to as the ventral surface. Two other descriptive terms, lateral and medial, are also used. Lateral means towards the side; medial means towards the midline. Frequently, these terms are joined together to form other terms. Thus, structures might be described as dorso-medial or ventro-lateral.

Table 3.1 Some terms and prefixes frequently used to describe neuroanatomical direction and position

Term	Definition
dys-	partial loss of
a-	total loss of
distal	far from
proximal	near to
afferent	moving towards
efferent	moving away from
unilateral	on one side
bilateral	on both sides
coronal	vertical slice dividing into front and back halves
sagittal	vertical slice dividing into left and right halves
transverse	horizontal section parallel to ground
medial	towards the midline
caudal	towards the tail end
rostral	towards the front
anterior	towards the front
dorsal	top or back of
ventral	front end or ground-facing surface of
lateral	towards the side
ipsilateral	on the same side
contralateral	on the opposite side

Figure 3.1

Positional terms illustrated diagrammatically (from Kandel, E.R. *et al.*, *Essentials of Neural Science and Behaviour*, © 1995, McGraw-Hill/Appleton & Large, reproduced with permission of The McGraw-Hill Companies)

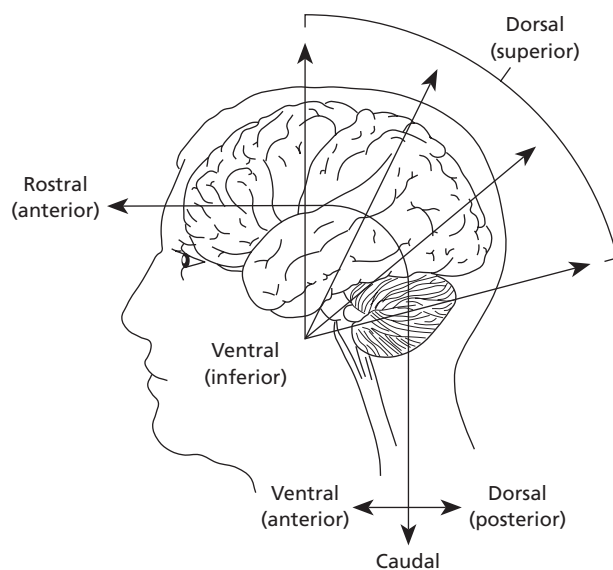

Processes or structures may also be prefixed with pre-, meaning before, and post-, meaning after, as in presynaptic and postsynaptic neuron. Processes such as axons may be afferent, meaning that they arrive at a particular region, or efferent, meaning that they are sent from a particular region. A useful mnemonic for learning the differences between these two is to think of afferents as arriving and efferents as exiting.

The prefix inter- refers to a process that lies between two other processes; the prefix intra- refers to a process that occurs within another process. Thus, interhemispheric refers to interactions between the two cerebral hemispheres, whereas intrahemispheric refers to interactions within one cerebral hemisphere. A process may also be described as ipsilateral, meaning on the same side, or contralateral, meaning on the opposite side. Thus anaesthetizing the left hemisphere will produce paralysis of the contralateral limb (the right arm).

When sections or views of the brain or spinal cord are considered, special terms are used to describe the ways in which the brain has been 'sliced'. This slicing is literal when the brain is studied *post mortem*, metaphorical when the living brain is studied via imaging methods. A coronal section is made as if one is slicing salami from front to back end, as seen in Figures 3.2 and 3.3. A horizontal section is one that is made parallel to the ground. Thus, if you imagine looking down onto the top of the brain, slices would be made as if taking the top off an egg, as seen in Figures 3.4 and 3.5. Finally, a sagittal section refers to slicing that is perpendicular to the ground. Again, imagine looking down onto the top of the brain but this time making slices from left to right.

Figure 3.2Coronal section of a human brain (from DeArmond *et al.* 1989)

Figure 3.3

Coronal section seen via an MRI scan

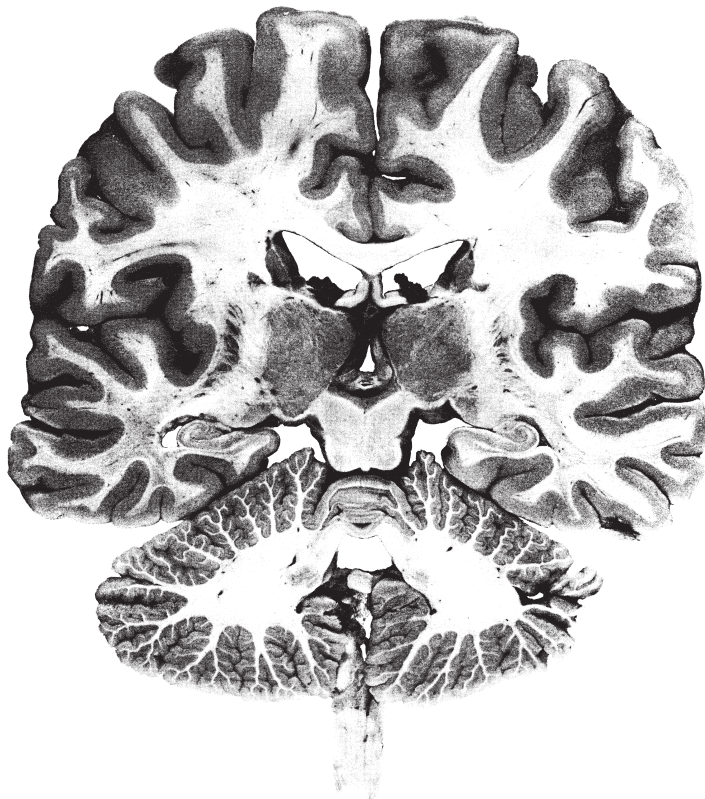
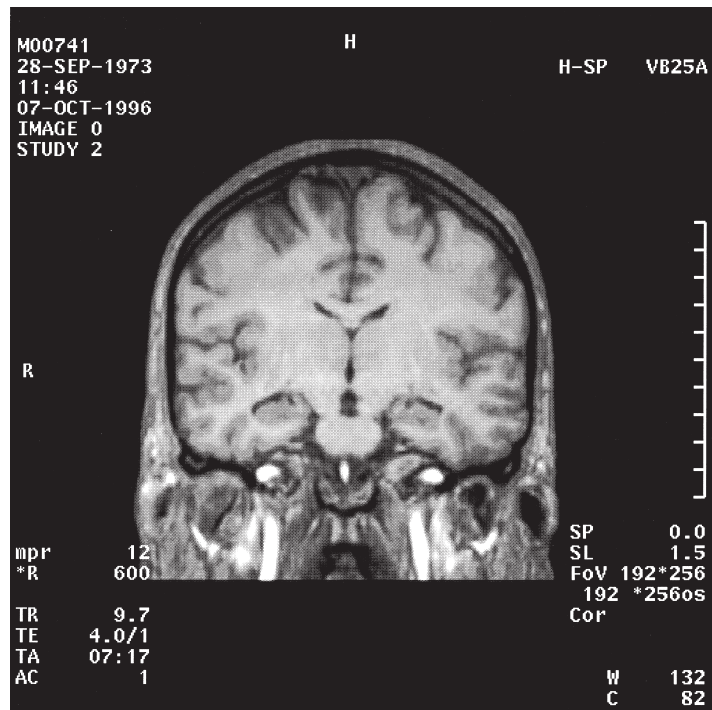
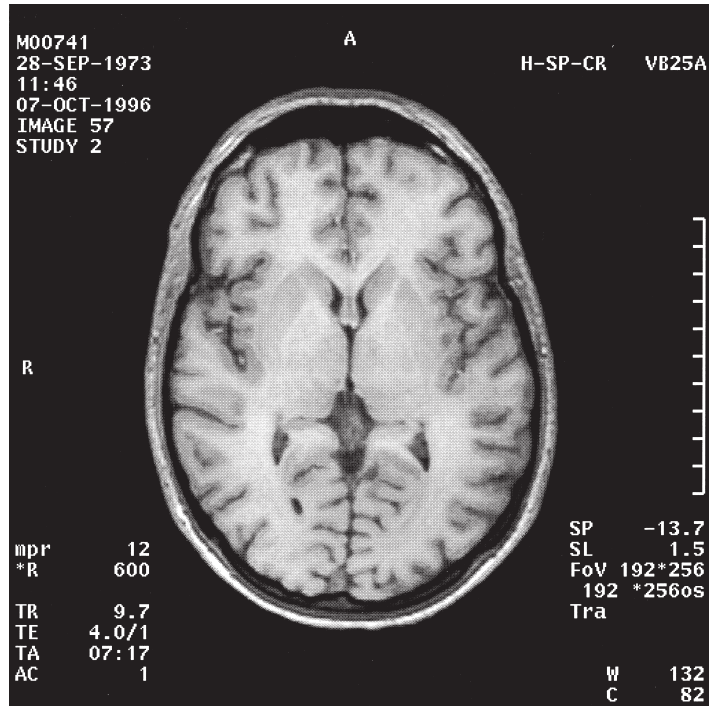

Figure 3.4

Horizontal section of a human brain (from DeArmond *et al.* 1989)

Figure 3.5

Horizontal section seen via an MRI scan



Development of the central nervous system

A human embryo begins life as a hollow tube called a neural tube. As the embryo develops, the tube elongates and folds and its tissue thickens. The wall of the tube is made up of cells that will later become the glial cells and the neurons of the nervous system. At this stage, these cells are called neuroepithelial cells: the prospective glial cells are called spongioblasts, and the prospective neurons are called neuroblasts. The inside of the tube is hollow, forming a canal that contains cerebrospinal fluid (CSF), a clear, watery liquid that serves a number of functions in the CNS and is described more fully later. The head of the embryo develops into the brain; the remainder straightens and becomes the spinal cord.

The canal develops four protuberances, which later develop into the brain's four ventricles – chambers deep inside the brain – which contain CSF. The spinal cord end of the canal becomes one, long, fluid-filled canal that connects the four ventricles of the brain. The ventricles help to divide the brain into various general regions called the forebrain, midbrain and hindbrain. The rostral ventricles are called the lateral and third ventricles. The region surrounding the lateral ventricles is called the endbrain or telencephalon and represents the most recently developed and most sophisticated part of the CNS, the cerebral cortex. The area surrounding the third ventricle becomes the diencephalon, or interbrain. These general and further subdivisions are seen in Figure 3.6.

Figure 3.6

Principal divisions of the central nervous system (from Kandel, E.R. *et al.*, *Essentials of Neural Science and Behaviour*, © 1995, McGraw-Hill/Appleton & Large, reproduced with permission of The McGraw-Hill Companies)

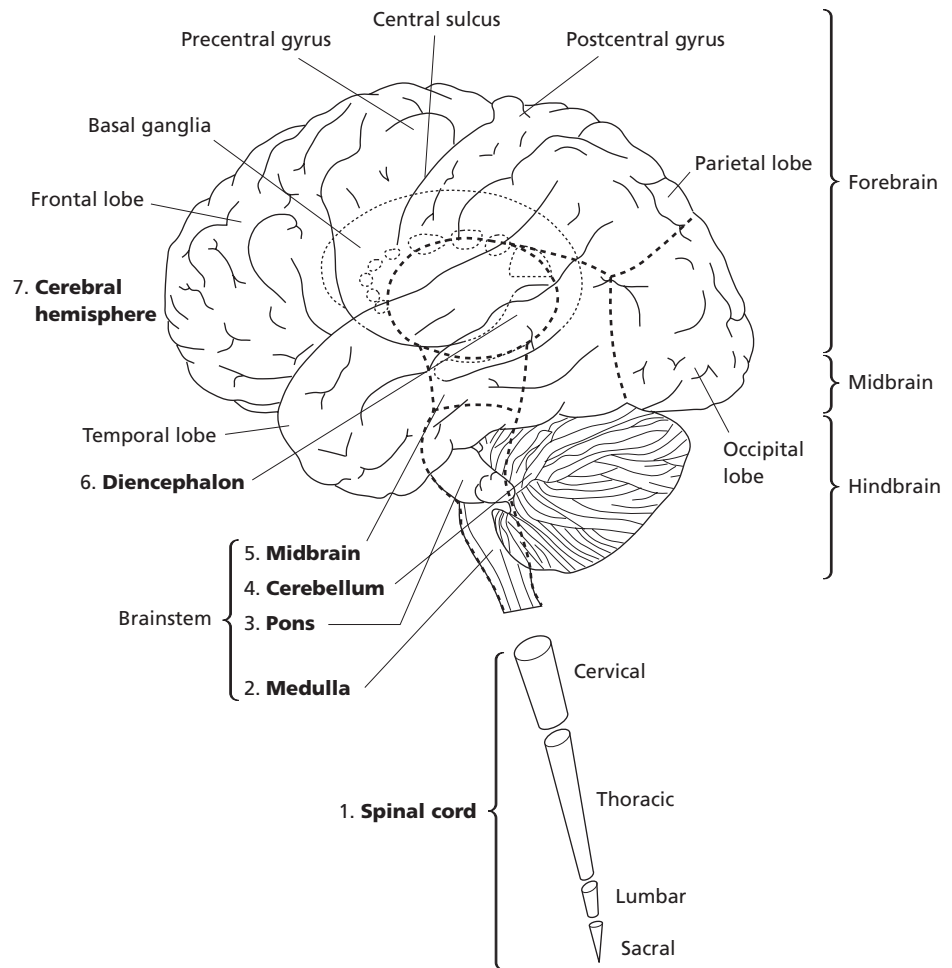

Spinal cord

The spinal cord is about the size of your little finger in diameter, measures about 40–45 cm and is cylindrical. It gives off a whitish colour because the outer part is made of axons. It is encased in a column of bone, called the vertebral column, a snake-like structure that is longer than the spinal cord and helps to protect the cord. The bone is made up of twenty-four vertebrae, which are described according to the region that they protect. Thus, starting from the top of the cord, there are seven cervical vertebrae, twelve thoracic and five lumbar vertebrae, as seen in Figure 3.7.

These vertebrae protect the parts of the cord at the neck, chest and lower back areas, respectively. At certain points, the vertebrae are not separate but fused. These are the sacral and coccygeal vertebrae, which are found towards the column's caudal end. The spinal cord runs along the inside of the column through a space called the spinal foramen

Figure 3.7

The spinal cord and vertebrae (from Carlson, Neil, R. *Foundations of Physiological Psychology*, 3rd edition. Published by Allyn and Bacon, Boston, MA. Copyright © 1995 by Pearson Education. Reprinted by permission of the publisher)

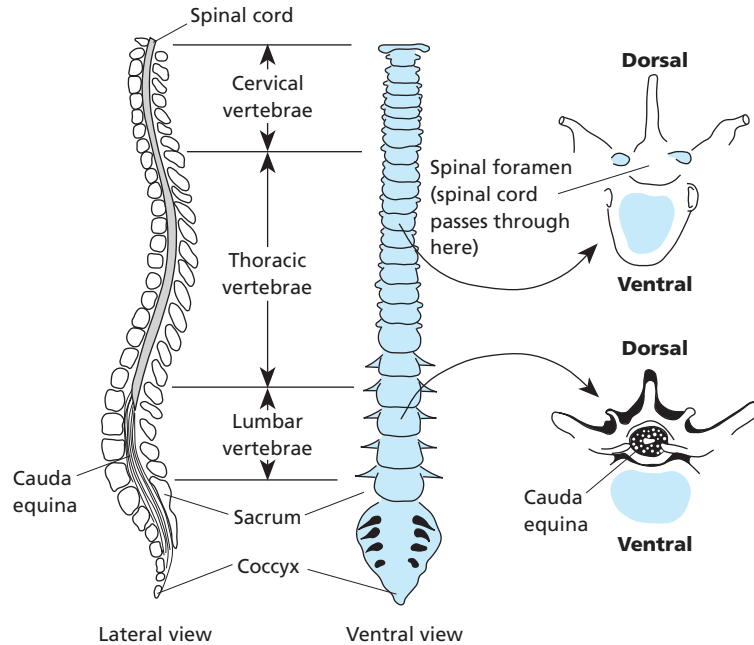

(plural, foramina), which is found in each vertebra. As mentioned above, there is more column than there is cord. The reason for this is that the spinal cord ends in a collection of spinal roots called the cauda equina (literally, 'horse's tail' and so called because these roots look like a horse's tail). The cauda begins at the second lumbar vertebra and ends at the coccyx. Thus, vertebrae also extend to part of the cauda, thereby protecting them too.

In relation to the body, the spinal column is found on the dorsal surface and at the mid-line of the back and extends to the second lumbar vertebra. The spinal cord extends to the bottom or inferior end of the brain, the brainstem, at a wedge-shaped structure called the medullary conus. In fact, the cord is thicker at its brainstem or cervical end but is unequally thick along its course. Its other thicker aspect is in the lumbar region. The cord also exhibits narrow indentations, called sulci, where the spinal nerves reach the cord.

Spinal nerves

The spinal nerves make up part of the PNS, a system that helps to mediate communication between the CNS and other parts of the body. Given the importance of the spinal cord for motor and sensory behaviour, such connections are vital. Peripheral nerves enter and exit the spinal cord in small bundles of axons called rootlets. These eventually unite to form a thicker process called a root. Thus, dorsal (posterior) and ventral (anterior) roots enter and exit the spinal cord. The dorsal root is special in that it has a swelling called a spinal ganglion, which contains the cell bodies for sensory axons entering the cord. Together, the dorsal and ventral roots make up the spinal nerve. There are

thirty-one pairs of spinal nerves, one on each side of the cord, and all but the first cervical pair leave the cord via spaces between vertebrae. There are twelve pairs of thoracic spinal nerves, five pairs of lumbar spinal nerves, eight pairs of cervical spinal nerves, five pairs of sacral and one pair of coccygeal. The two types of root convey different types of information. The ventral root contains efferent motor fibres; the dorsal root contains afferent (sensory) fibres.

The grey matter extends along the length of the cord and contains a very small and narrow central canal, which ends before the cauda equina but extends upwards into the brain's ventricular system. The grey matter also contains neurons, which send axons to the higher levels of the CNS. These are found in the dorsal horn side, or again, more strictly, in the area where dorsal and ventral horns meet, and they inform the brain of the spinal cord's activities. For example, sensory receptors (from the skin, for instance) send information to the spinal cord via sensory afferent fibres. These enter the dorsal roots and branch out to form synapses with the grey matter's terminal buttons. Sensory neurons found in the spinal ganglion send dendrites to sense organs and an axon to the spinal cord.

Finally, the grey matter contains neurons that communicate with other neurons either within a segment or above and below a segment of the spinal cord. These are called spinal interneurons and are important because they form synapses with motor neurons, which can mediate the motor response to sensory stimuli. There are also different types of spinal axon called propriospinal fibres. These belong to the axon of one neuron, which sends collaterals to other spinal segments.

Brainstem

The brainstem is actually a continuation of the spinal cord. It is made up of fairly distinct regions including, from bottom to top, the medulla oblongata, the pons, the mesencephalon and diencephalon, as seen in Figure 3.6.

The brainstem is characterized by its ventricles, the fourth and third of which are found in the pons and diencephalon, respectively. The brainstem is also characterized by nuclei that belong to twelve pairs of cranial nerves. All of these nerves apart from the first, the olfactory nerve, arise in the brainstem, and all twelve pairs are numbered according to where they emerge on the surface of the brainstem. The cranial nerves are described more fully later in the chapter.

In the core of the brainstem, there is a mass of neurons called the reticular formation, an interesting collection of fibres that is thought to be responsible for mediating quite different types of behaviour. Thus some parts of it are involved in sleep, others in respiration. Its activity has also been thought to provide a biological basis of the personality dimensions extroversion and neuroticism.

Medulla oblongata

The next major part of the brainstem is the medulla oblongata. The ventral median fissure, an indentation of the spinal cord, continues to the medulla oblongata, where it forms a longitudinal fissure. There are collections of processes called pyramids (because of their shape) on each side of the fissure. These are made up of axons belonging to the pyramidal

tract, an important bundle of fibres (in fact, one million of them) that sends signals from the cortex to the spinal cord. At the bottom of the medulla, the axons cross over, forming a pyramidal decussation. The medulla also contains fibres from the dorsal column nuclei, which form the medial lemniscus. This receives sensory information from the skin and muscle surrounding the joints.

Pons

The medulla oblongata extends into the pons (meaning bridge), a structure that contains a large cell group called the pontine nuclei. These send projections to the cerebellum, connecting it to form the middle cerebellar peduncle. The pons is an important structure because several of the cranial nerves exit here.

Mesencephalon

The mesencephalon is the next clear region up from the pons and is quite short. On each side of the midline of the midbrain are the cerebral peduncles (*crus cerebri*). It contains four small, rounded bumps called colliculi. There are two pairs, inferior colliculi and superior colliculi, involved in the relay of auditory and visual information, respectively. As with other brainstem structures, the mesencephalon also contains cranial nerves. Near the colliculi is an aqueduct that joins the third and fourth cerebral ventricles. Surrounding this aqueduct is a region of grey matter called the periaqueductal grey substance, an important region for the sensation of pain. Finally, the mesencephalon contains the substantia nigra ('black substance'), an important area next to the *crus cerebri* that is involved in the regulation of movement and is often referred to as part of the basal ganglia (see below).

Diencephalon

The next region up from the mesencephalon is the diencephalon, which comprises two principal structures called the thalamus and hypothalamus. The thalamus is a structure that resides on each side of the third ventricle and has a flattened, egg-shaped appearance. It plays a vital role as a relay station for almost all information coming from the lower brainstem and CNS on its way to the cortex. To its side is a thick covering of white matter called the internal capsule, which has fibres connecting the cerebral cortex to the rest of the CNS. This extends into another structure, the corpus callosum, which is a thick band of fibres that connects the two cerebral hemispheres.

A Y-shaped band of white matter, called the internal medullary lamina, divides the thalamus into different regions of nuclei. Among the thalamic nuclei that can be observed are the medial thalamic nuclei, the lateral thalamic nucleus and the anterior thalamic nucleus, all of which are described by their position. These nuclei can themselves be subdivided into smaller nuclei. One large set of nuclei in the posterior part, called the pulvinar, partly covers two other nuclei: the lateral geniculate body and the medial geniculate body. The first of these bodies acts as a relay station for visual information, the second as a relay station for auditory information. The importance of the diencephalon to vision does not end here. The optic nerves themselves, which deliver information from each retina, course under the diencephalon and meet, forming a chiasm. Here, there is a

partial crossing over of fibres so that some axons cross to the contralateral hemisphere. Fibres leaving this chiasm form an optic tract. The remainder of the visual pathway is described in the section on sensory and motor systems below.

Beneath and anterior to the thalamus lies the hypothalamus. This is another important structure and is responsible for mediating autonomic nervous system function and behaviour such as aggression, feeding and sexual activity. Protruding posteriorly from the hypothalamus are the mammillary bodies. The fornix, a thick arching collection of fibres, extends from the cerebral cortex and ends in the hypothalamus. Both the mammillary bodies and the fornix are thought to play a special role in memory and learning. The motor efferent fibres sent to the thalamus by the mammillary bodies form the mamillothalamic tract.

Finally, one other structure in the diencephalon is the pituitary gland, which is important for the secretion of hormones.

Cerebellum

The cerebellum (literally, little brain) extends from the pons and is responsible for the execution of movement and maintaining balance of posture. The cerebellum is located beneath the cortex and posterior to the brainstem. Its name, 'little brain', nicely describes the structure, because it does look like a small brain attached to the back of the brainstem. It has its own covering or cortex of grey matter called the cerebellar cortex, beneath which lies white matter. The white matter itself contains the cerebellar nuclei; most of the cerebellum's efferent fibres originate here. The white matter has a distinctive appearance, like a mature, leafy tree. Because of this, it is called the arbor vitae (literally, tree of life).

Like the cerebral cortex, the surface of the cerebellum has a convoluted appearance, i.e. it has a number of folds, called folia because they are like narrow folded sheets. It also displays various grooves on its surface, which divide the structure into lobes. In the middle of the cerebellum is a narrow region called the vermis.

There are stalks connecting the brain stem to the cerebellum, called the inferior, middle and superior peduncles. Two of these bring information from various parts of the CNS, and one sends fibres to the CNS. The two peduncles receiving afferents are the inferior (or restiform body) and middle (brachium pontis) peduncles. The former receives input from the spinal cord; the latter receives fibres from the cerebral cortex. The superior peduncle (or brachium conjunctum) sends efferents to the CNS. The fourth ventricle forms part of the cerebellum.

Cerebral cortex

The largest and outer part of the brain is called the cerebral cortex and fills most of the skull. A view of the brain from above shows that it has a curved and relatively smooth surface, in contrast to the underneath of the brain – the brainstem – which has an extremely uneven surface. The name 'cortex' means bark, an appropriate name given the position of the tissue but one that does not describe its texture very well (this is soft and jelly-like).

The most obvious physical characteristic of the cortex (or neocortex) is its convoluted appearance. It looks wrinkly. The reason for this is that the cortex actually comprises several compressed sheets. Imagine trying to fit a sheet of A4 paper into a 4 × 4-inch wooden box without altering the shape of the paper. It would be impossible. However, if you crumpled the paper, it would fit. The cortex has developed in similarly crumpled fashion in order to meet the constraints imposed by the skull. An advantage of this crumpling is that it increases the surface area of the brain that can be fitted inside the skull.

Fissures and sulci

The convolutions, or grooves, on the cortex are called fissures or sulci (singular, sulcus). They can be seen in Figures 3.8 and 3.9. Fissures describe very deep grooves; sulci describe more superficial ones. The surfaces of the cortex lying between these grooves are called gyri. Each hemisphere contains one large fissure called the lateral, or Sylvian, fissure. This, as its name suggests, extends laterally and medially down each hemisphere. At the end of these fissures, there are gyri that form the region called the insula.

Although there is tremendous individual variation in the appearance and length of fissures and sulci, some are well described and are common. For example, one groove in the middle of the brain extending inferiorly is called the central sulcus or Rolandic fissure. In front of this is the precentral gyrus. Together these two gyri form the cortical area responsible for motor movement. Damage to these gyri can result in paralysis in the contralateral side of the body. The gyrus appearing after the central sulcus is called the postcentral gyrus and is the region responsible for receiving sensory information from the skin and muscles. This is also called the somatosensory cortex or SI.

Lobes of the brain

The fissures and sulci appear to divide the brain into geographically distinct regions. These regions are called lobes and there are four of them: frontal, temporal, parietal and occipital, as seen in Figure 3.9. However, there is no real underlying logic to the description of these lobes because it is not based on the lobe's actual functional characteristics although it is true that one lobe may be more responsible for a certain function than another. For example, the occipital lobes contain the primary visual cortex; the superior temporal gyrus of the temporal lobe contains the primary auditory cortex, which receives impulses from the ear, or more specifically, the cochlea. These areas are thus described as the auditory cortex, the visual cortex, the motor cortex, and so on. In addition to these cortices, there are areas known as association cortex areas, which lie outside the primary motor or sensory area but which have reciprocal connections with these regions.

The lobes of the cortex are in fact named after the skull bone that they underlie. Some lobes' names are very recent in origin. The part of the cortex called the occipital lobe also contains a white stripe running parallel to the cortex. Because of this, the occipital lobe is also called the striate area or cortex. The principal functions of the occipital lobe are considered later in this chapter. The frontal lobes occupy a chapter of their own (Chapter 5).

Temporal lobe function

The temporal lobes are the brain regions primarily responsible for audition (hearing), language comprehension, memory and learning and, possibly, olfactory perception, detection and identification. These lobes are particularly important for hearing, because they contain

Figure 3.8

(a) Dorsal view of a human brain; (b) schematic of a human brain (from DeArmond *et al.* 1989)

(a)

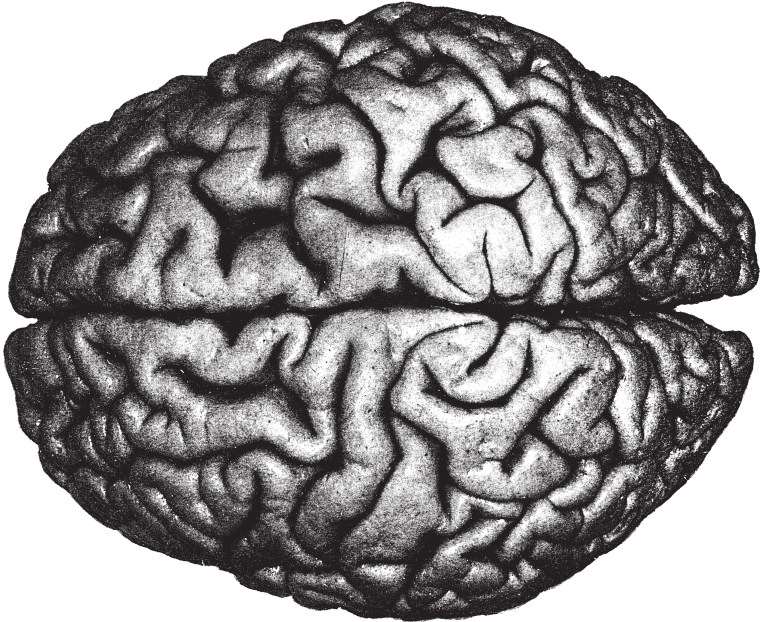

(b)

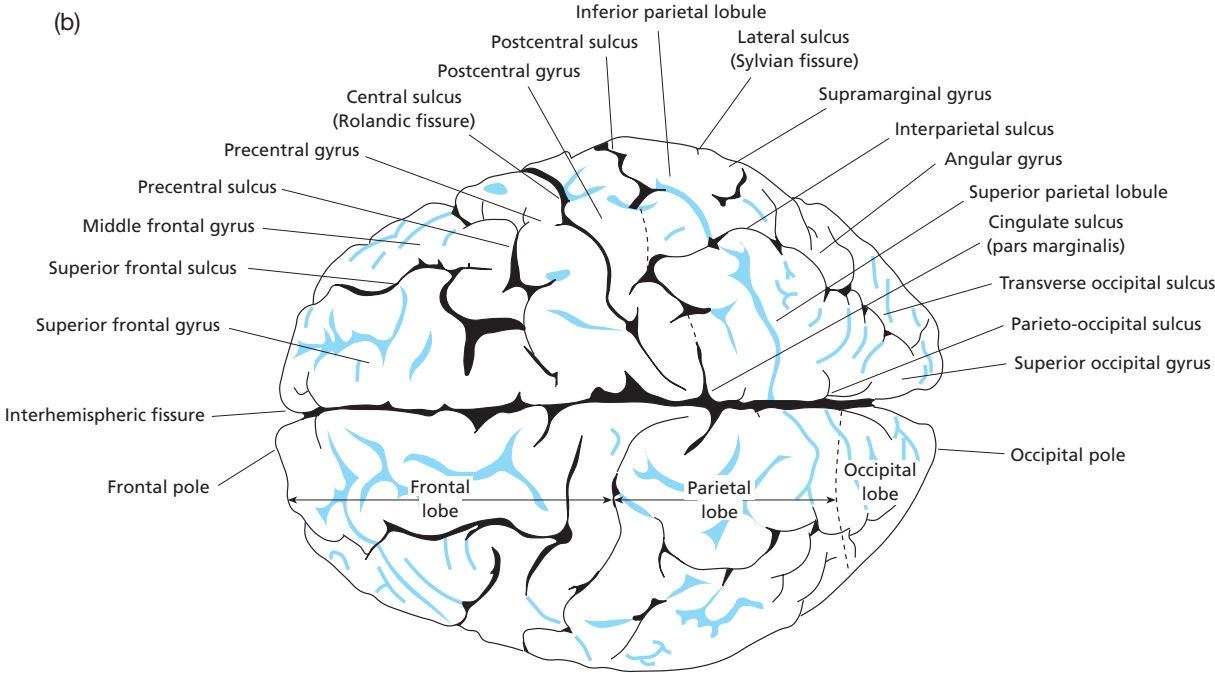
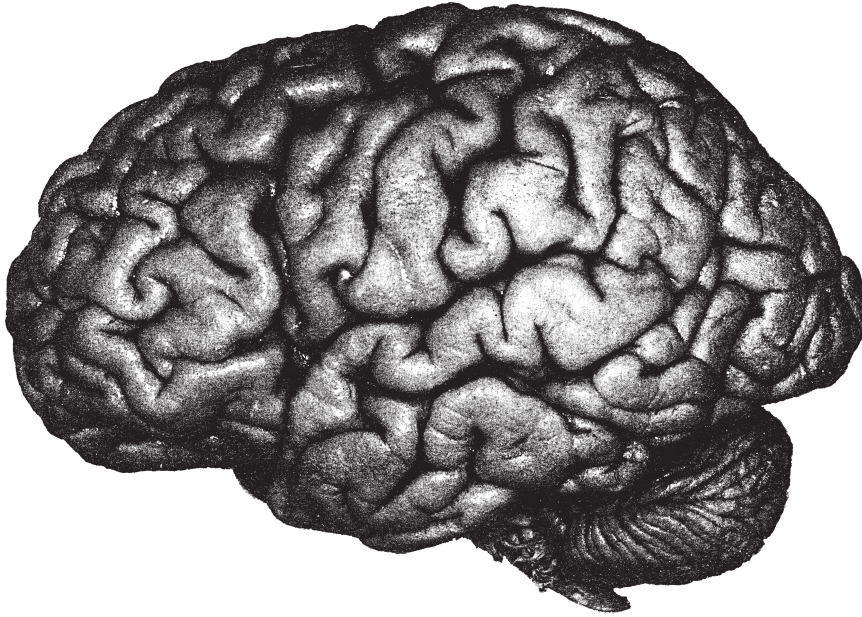

Figure 3.9

(a) Lateral view of a human brain; (b) schematic of a human brain (from DeArmond *et al.* 1989)

(a)



(b)

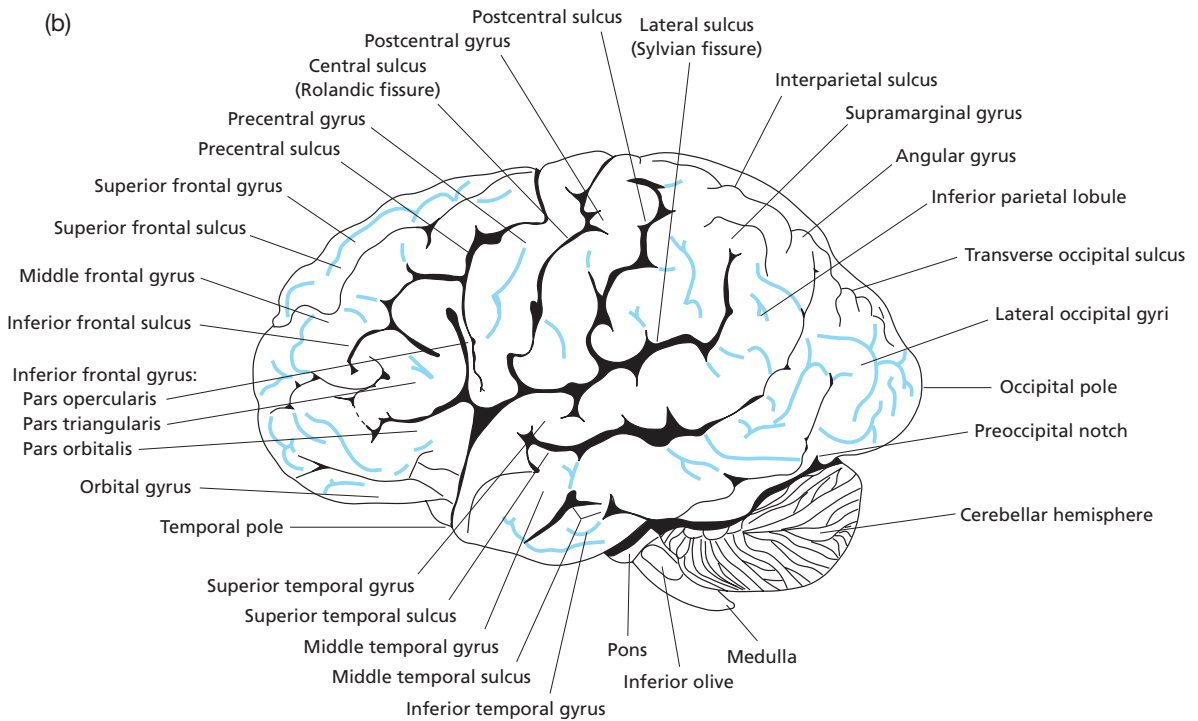

both the primary auditory cortex and the auditory association areas. Bilateral damage to area 41 (Heschl's gyrus) might lead to cortical deafness. Unilateral lesions to this area result in less severe auditory consequences, such as a reduction in the threshold for auditory sensation. Damage to other regions of the auditory cortex can lead to musical deficits such as tone deafness or poor pitch/melody perception (musical agnosia) or an inability to comprehend non-verbal sounds (sound agnosia). Language comprehension is most affected by unilateral lesions to area 22 or Wernicke's area (see Chapter 8), and memory and learning deficits can also result from temporal lobe damage, as you will see in Chapter 9. Inevitably, when memory and learning impairments arise from temporal damage, personality is changed as a result. Finally, damage to the right temporal (and orbitofrontal cortex) has been associated with deficits in odour recognition memory (Jones-Gotman and Zatorre 1993).

Parietal lobe function

The parietal lobes contain the primary and association cortices for somatosensation. Damage to the parietal cortex has been found to produce deficits in behaviour such as tactile (haptic) perception and touch discrimination. At the behavioural level, the parietal cortex is also important for mediating attentional processes such as directing an organism towards information that is relevant. In monkeys, the specific region responsible is area 7 (the inferior parietal lobe or IPL; see Figure 3.10); in humans, there is a homologous region in the superior parietal lobe. Neurons in the IPL selectively fire when a monkey performs a motor act, but this activation differs according to the context in which an identical motor act occurs. For example, the same motor act may be involved in eating or placing, but it activates the IPL differently depending on the context (Fogassi *et al.* 2005). Neurons here also fire during the observation of a motor act and before the beginning of subsequent acts that define the precise action.

Together with attention and motor movement, activation in this region is also reported during auditory and haptic attention, motion processing, stereo vision, spatial and non-spatial working memory, mental imagery, and arithmetical calculation (Culham and Kanwisher 2001). As the parietal lobe also contains the motor cortex, damage to the motor area can result in impairments in gross limb movement. Finally, parietal cortex damage is often associated with deficits in spatial representation such as spatial neglect, where the patient is unable to 'see' objects in one half of the visual field, a phenomenon discussed in Chapter 6, or sensorimotor coordination problems, as seen in constructional apraxia, the inability to copy a drawing in the absence of a neurological motor impairment (discussed in Chapter 7).

Figure 3.10

The area of the parietal lobe activated in Fogassi *et al.*'s (2005) experiment (Reprinted with permission from, Parietal lobe: from action organization to intention understanding, *Science*, 308, 662–7, Figure 1a, Fogassi *et al.* © 2005 AAAS)

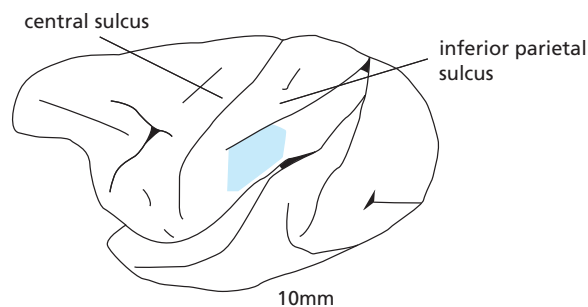

Because of the wide range of relatively task-non-specific, process-general functions implicating activation of the parietal lobe, one notion of its role sees it as an association cortex – an area where various functions converge. Alternatively, it may be a region that is simply a general cortical mediation centre. These observations have been based on data from neuroimaging studies, although, as Culham and Kanwisher (2001) concede, the lobes may be more functionally specialized than crude imaging methods suggest. Given that most tasks in neuroimaging studies involve attention, orientation, motor plan generation and eye movement directing, controlling for these factors would be critical before ascribing any specific function to this region.

Basal ganglia

Inside the cortex there are a number of small structures that are integral to the functioning of the human brain and behaviour. One such collection is called the basal ganglia, which are involved in certain aspects of movement, as illustrated by Figure 3.11. The basal ganglia receive connections from parts of the cortex and send axons to the motor cortex. They have two main parts. The smaller is found anterior to the thalamus, has a long, curved tail and is called the caudate nucleus. The caudate has a large part (called the caput) and a tail (the cauda) that points upwards then backwards into the temporal lobe. The larger part of the basal ganglia, found laterally to the internal capsule, is called the lentiform nucleus. The lateral and external part of this is called the putamen. The medial and internal part is called the globus pallidus.

Figure 3.11

The basal ganglia. The arrows show the pathways of the dopaminergic neurotransmitter system (from Carlson, Neil, R. *Foundations of Physiological Psychology*, 3rd edition. Published by Allyn and Bacon, Boston, MA. Copyright © 1995 by Pearson Education. Reprinted by permission of the publisher)

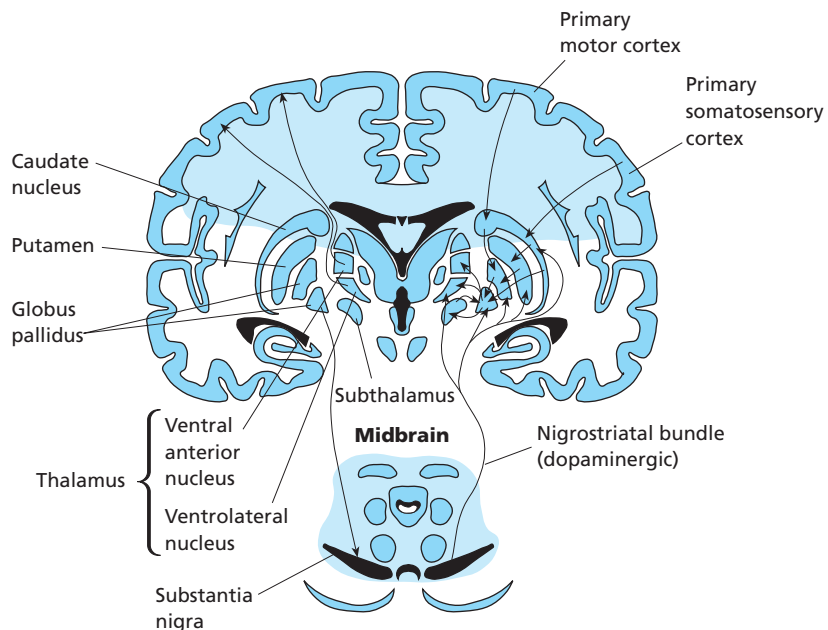

Limbic system

Another collection of structures important for behaviour represents part of the limbic system, a name given by the neuroanatomist Paul Maclean to a collection of subcortical structures that includes the hippocampus, the septal nuclei, the amygdala, the cingulate gyrus, the mammillary bodies and the hypothalamus (see Figure 3.12).

The limbic system is probably the oldest part of the brain and contains many of the structures involved in the most primitive behaviour such as feeding, copulating and aggressing. Originally, this part of the brain was called the rhinencephalon ('smell brain') because it was thought to be heavily involved in the regulation of the olfactory system. Broca had earlier coined the term 'limbic lobe' to describe these structures before Maclean dignified them with the status of a system (there is still argument over whether these structures actually do constitute a system). Whatever the merits and demerits of the description, the 'limbic system' is a useful shorthand description of connecting and interconnecting subcortical brain areas.

Figure 3.12

The limbic system: (a) general location of structures; (b) structures in detail (from Kandel, E.R. *et al.*, *Essentials of Neural Science and Behaviour*, © 1995, McGraw-Hill/Appleton & Large, reproduced with permission of The McGraw-Hill Companies)

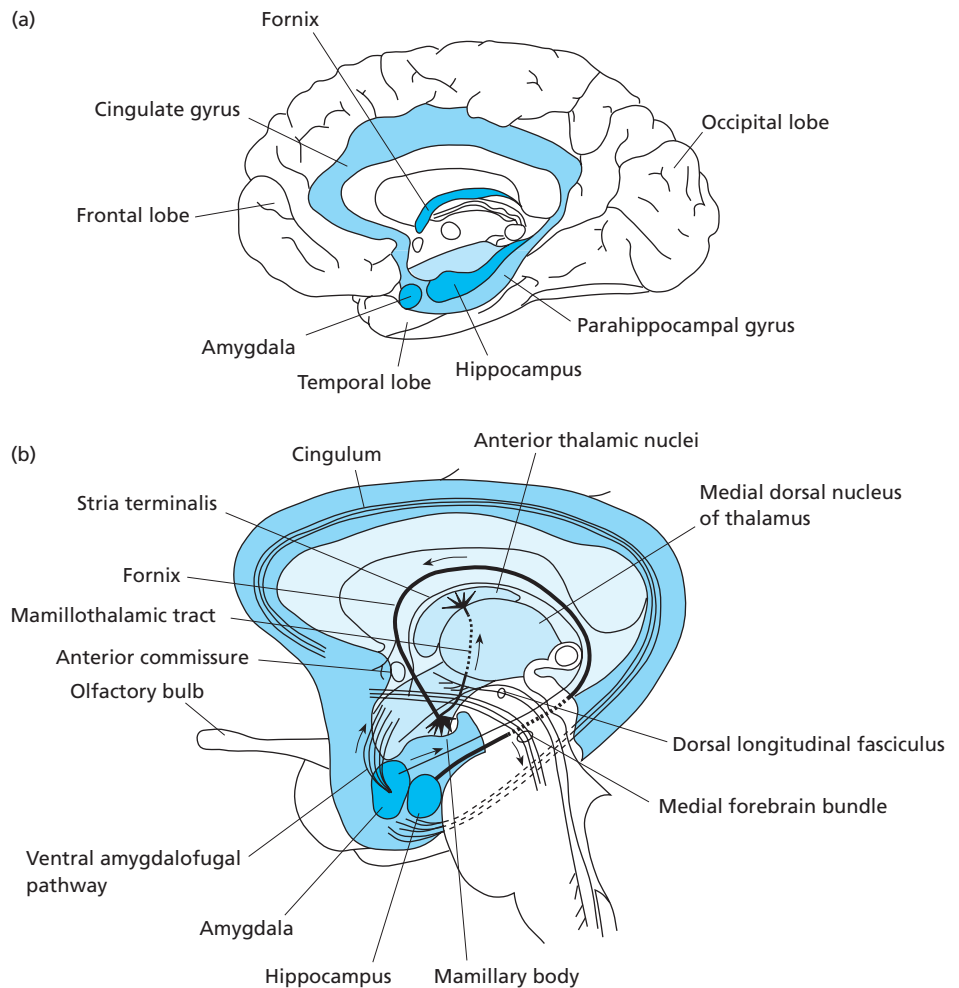

The hypothalamus, for example, has direct connections with most of the other parts of the limbic system. This structure in particular appears to be involved in the regulation of eating and drinking via connections with the amygdala. It also appears to be involved in regulating reproduction and body temperature. The amygdala, found in the temporal lobe anterior to the hippocampus and the horn of the third ventricle, has been thought to play a role in a range of behaviour, including face recognition, emotion and aggression. In laboratory animals whose amygdala has been destroyed, normal aggressiveness is abolished. The limbic system's role in emotion is discussed more fully in Chapter 10. As we will see below, the limbic system receives connections from other parts of the brain and receives information from all the sensory systems via the parahippocampal gyrus.

Finally, there is an area between the globus pallidus and brain surface called the substantia innominata. This contains two important sets of nuclei: the basal nucleus of Meynert (nucleus basalis of Meynert) and the nucleus of the diagonal band of Broca. The former has cholinergic axons projecting to the amygdala and cortex, the latter to the hippocampus and septum. Lesions of the nucleus basalis result in a dramatic reduction in acetylcholine, and impairment of these nuclei has been associated with memory deficits.

Organization of the cerebral cortex

The six layers of the cortex

As well as being convoluted, the cortex is also made up of six parallel layers or laminae, which are found perpendicular to the surface. The division of the cortex into six layers is made on the basis of cytoarchitecture: the number, size and density of cell bodies in the cortex. Neurons are not arranged randomly across the whole cortex.

About two-thirds of the neurons are pyramidal cells, so called because their cell bodies are shaped like pyramids. These tend to have a long axon and dendrite. The remainder of the neurons are non-pyramidal. In fact, there are other specific non-pyramidal cells, which are given names that reflect their appearance. Thus multipolar cells are called stellate cells. Chandelier and basket cells are named after their arrangement and appearance. The cortical layers contain neurons that either receive or send out axons; their main features are described in Table 3.2.

Table 3.2 The six layers of the cortex and the types of cell contained in them

Layer	Cell type
Layer 1: molecular layer	Contains few neurons; comprises axons and atypical dendrites from cell bodies in deeper layers.
Layer 2: external granular layer	Contains a large number of small, rounded cell bodies, densely packed.
Layer 3: external pyramidal layer	Contains pyramidal cells.
Layer 4: internal granular layer	Contains small, densely packed cell bodies. Well developed in sensory areas; further laminated in the striate cortex, where it is subdivided into layers 4a, 4b and 4c.
Layer 5: internal pyramidal layer	Contains large pyramidal cells (larger than those in layer 3).
Layer 6: multiform layer	Contains a large number of spindle-shaped cells.

Columns of the cortex

The cortex is also arranged in another way: it manifests distinct columns within these cortical layers. Each of these columns has a function that is not normally shared with immediately neighbouring columns. The existence of the columnar arrangement in the cortex was demonstrated by early electrophysiological studies in which electrodes were placed perpendicularly into the cortex. The neurons – regardless of the depth of the cortex reached – had the same receptive field. However, when the electrode was placed obliquely into the cortex, different receptive fields were recorded at each level. However, the columnar arrangement is not quite so simple. In a series of classic experiments, summarized by Hubel and Wiesel (1979), it was found that the visual cortex is arranged in bands rather than columns. Thus a column might reach a layer or two above or below, but it would not reach all.

Connections between brain regions

Quite specific connections are made between certain brain regions. Perhaps the most important are connections between the thalamus and the cortex (thalamocortical connections), between one region of the cortex and another (corticocortical connections) and between large areas of cortex and another (commissures). Corticocortical connections are usually reciprocal, i.e. the sending area receives fibres from the region that it sends to.

Thalamocortical connections

As we saw earlier, the thalamus is made up of several different nuclei, which supply different parts of the cortex with afferents. As we also saw earlier, the thalamic nuclei provide a relay station for those impulses sent from sensory receptors to the cortex. So, for example, the ventral nucleus of the thalamus receives impulses from the somatosensory receptors and projects to the somatosensory cortex. The lateral geniculate body acts as a relay station for the pathway from the retina to the striate or visual cortex. The medial geniculate body serves a similar function for audition (projecting to the auditory cortex). Other nuclei mediate pathways between the cerebellum and the basal ganglia, and the motor or premotor cortex. The anterior thalamic nucleus receives axons from the mammillary bodies and projects to the cingulate gyrus, whereas the mediodorsal thalamic nucleus receives axons from the amygdala and projects to the frontal lobes. The posterior part of the thalamus projects to the posterior parietal cortex. These connections are usually reciprocal, providing ‘feedback loops’.

Association areas

Many of the connections made within the cortex are made via association cortices, seen in Figure 3.13. These cortices do not receive inputs from sensory or motor receptors directly but do receive projections from the primary sensory and motor cortices. The role of the association cortices appears to be to integrate information and to send back information to other parts of the cortex.

For example, the association area found in areas 5 and 7 of the parietal cortex (the posterior cortex) integrates somatosensory and visual information and sends projections to the premotor and motor area. For this reason, damage to the parietal association cortex can produce disturbances in voluntary movement, the inability to grasp or manipulate objects in the absence of paralysis (the patient might, for example, pour water from a jug

Figure 3.13

Cortical areas and association areas of the brain (from Kandel, E.R. *et al.*, *Essentials of Neural Science and Behaviour*, © 1995, McGraw-Hill/Appleton & Large, reproduced with permission of The McGraw-Hill Companies)

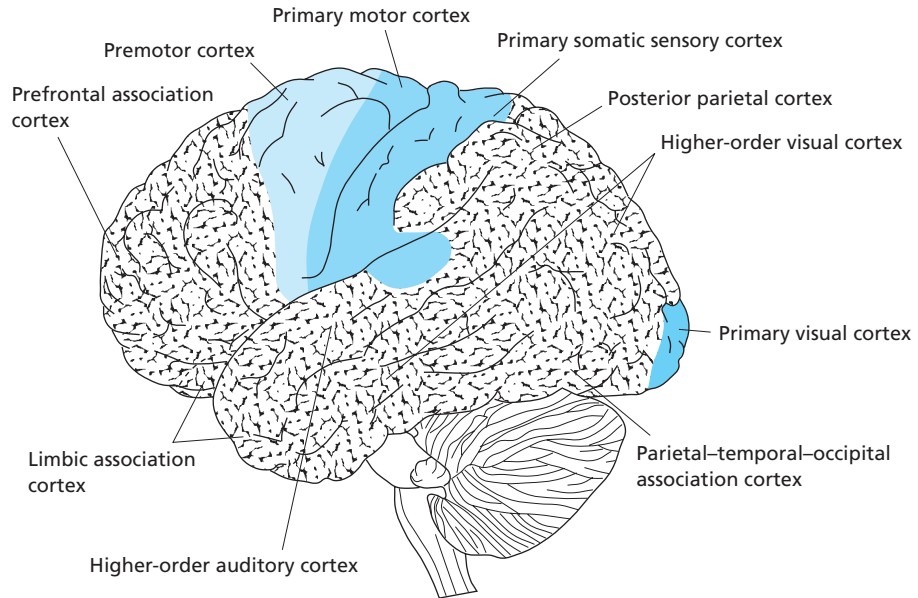

outside the glass rather than into it), a deficit in drawing and copying ability, an inability to use tools correctly and, when damage is to the right hemisphere, neglect of the side of the body contralateral to the lesion (see Chapter 6).

The association area of the frontal lobes is the prefrontal cortex and is found at the anterior end of the frontal lobe. This is a rather important association area because it receives connections from all sensory modalities and also has connections with areas responsible for mediating emotion. For this reason, the frontal lobes have been described as the brain's 'orchestra leader', a role that is described more fully in Chapter 5.

Finally, the temporal association area comprises the superior temporal gyrus (which connects with the primary temporal cortex) and the inferior temporal cortex (which has connections with the extrastriate visual area). The types of deficit that follow temporal association cortex damage include memory loss (amnesia, but only if damage is bilateral), visual agnosia (the inability to recognize objects) and the inability to interpret complex visual stimuli. The basis for these deficits is returned to in Chapters 6 and 9.

Cranial nerves

Earlier, we noted that the peripheral nervous system contains major nerves that are necessary for the execution of essential behaviour such as seeing, hearing, smelling, swallowing and salivating. These nerves convey information from the senses to the brain, which in turn integrates and tries to make sense of this information. They are also necessary for certain head and trunk movements. These are the twelve cranial nerves and they originate or terminate in the brainstem. Their location and projections can be seen in Figure 3.14, where they are numbered in the order encountered in the brain, anterior to posterior.

Figure 3.14

The cranial nerves (from Carlson, Neil, R. *Foundations of Physiological Psychology*, 3rd edition. Published by Allyn and Bacon, Boston, MA. Copyright © 1995 by Pearson Education. Reprinted by permission of the publisher)

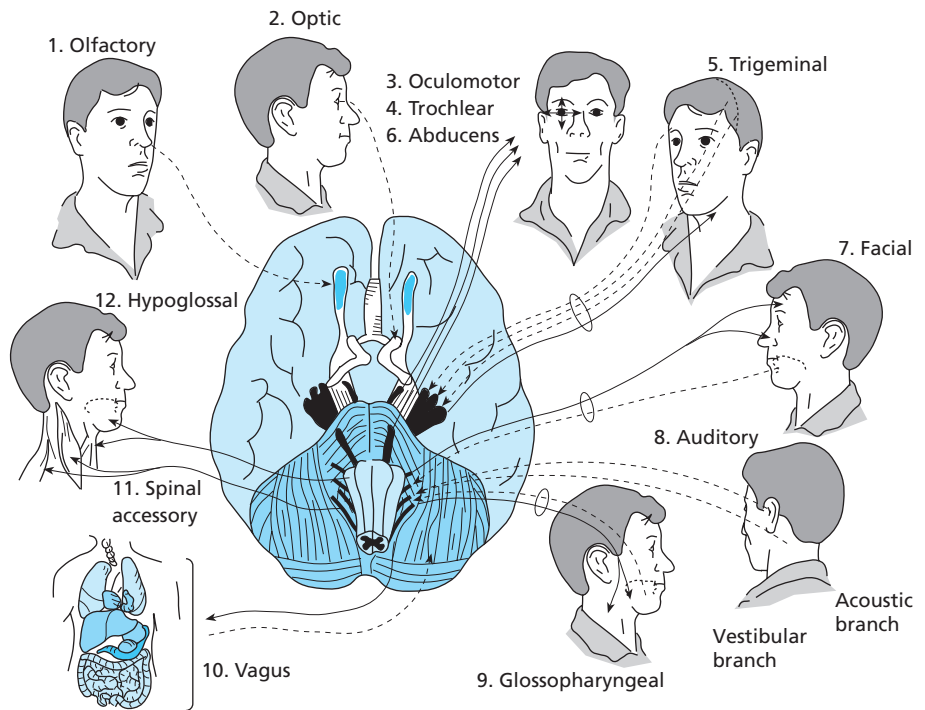

Covering the brain

In addition to hair, scalp and skull, the brain has other layers of protection that directly surround it. These are membranes, called meninges, and there are three of them (these layers also cover the spinal cord). The immediate covering is called the pia mater. This covers the brain very closely and covers all sulci and fissures.

The second covering is the arachnoid mater. Unlike the pia mater, this covers over the sulci. The space between this layer and the pia mater is called the subarachnoid space, which is found all over the CNS. It is filled mostly with cerebrospinal fluid but also contains thin threads of tissue that connect the two layers. Sometimes, a blood vessel in the brain might rupture, causing subarachnoid haemorrhage, where the blood mixes with the cerebrospinal fluid. The subarachnoid space is not equal across the cortex: some spaces are larger than others. These spaces are called cisterns, and the largest of them is found below the cerebellum.

Finally, the third and outer layer of the brain is called the dura mater ('hard matter'). There is not much space between the arachnoid and the dura mater, but what there is called the subdural space. The third layer is tough and covers the inside of the skull. It has indentations that limit the movement of the brain. This layer covers all of the CNS,

including the cauda equina. When it reaches the cauda, it forms a sac called the dural sac. This region is where a clinician might perform a lumbar puncture in order to obtain a sample of CSF (the contents of the CSF can give many clues about possible brain dysfunction). The spinal cord would not be damaged, because spinal nerve roots are the only fibres in this region.

Ventricular system

The cerebrospinal fluid (CSF) is found in the brain's cavities or ventricles, as illustrated by Figure 3.15. The canal of the spinal cord extends up to the brainstem, where it forms the fourth ventricle. The cerebellar peduncles joining the cerebellum to the brainstem form a tent-like shape, which is filled with CSF. The next ventricle is the third ventricle, which comprises a narrow space between the two thalami. The first and third ventricles, called lateral ventricles, are found in the parietal lobes, just above the thalamus, and extend horns into each of the other lobes. The anterior horn (the largest) extends frontally, the posterior horn extends occipitally, and the inferior horn extends temporally.

Cerebrospinal fluid is made by small vascular tufts called choroid plexuses, which are attached to the walls of the ventricles by a thin stalk. CSF has the same sodium and potassium concentration as blood but contains only two-thirds of blood's glucose content. It contains neurotransmitters, neuropeptides and hormones. The fact that it contains neurotransmitters suggests that obtaining a sample of the CSF will give us a measure of neurotransmitters' and other substances' levels in extracellular fluid.

About 0.5 litres of CSF is produced each day, but only about 150 ml is found in the ventricles and subarachnoid space. There is an effective drainage system that removes the excess fluid. The CSF also helps to protect the brain from extreme pressure (such as a blow to the head) because it makes the brain lighter (by about 1300 g). The brain is made buoyant by this fluid; when a blow is received to the head, this fluid has to be pushed aside before the brain hits the skull.

Figure 3.15

The ventricles of the brain (from Carlson, Neil, R. *Foundations of Physiological Psychology*, 3rd edition. Published by Allyn and Bacon, Boston, MA. Copyright © 1995 by Pearson Education. Reprinted by permission of the publisher)

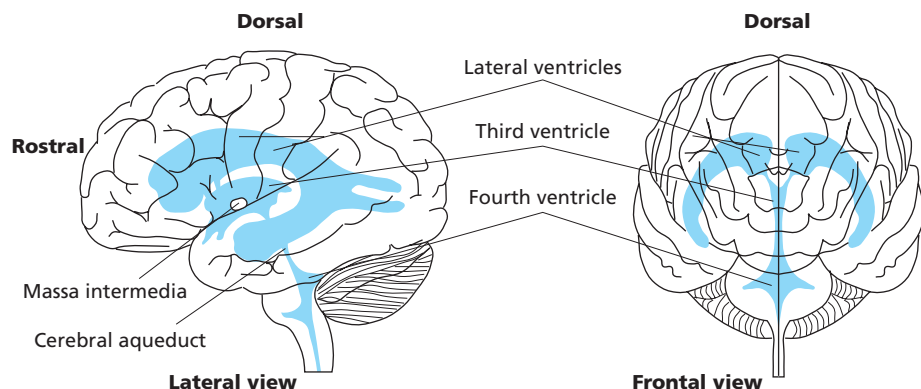

Arteries of the brain

The blood supply to the brain is provided by the internal carotid artery, which supplies the cortex, and the vertebral artery, which supplies the brainstem and cerebellum. The arteries supplying the brain are seen in Figures 3.16 and 3.17. The carotid artery enters the cavity of the skull and divides into three other arteries: the ophthalmic artery, the anterior cerebral artery and the middle cerebral artery (the largest). Branches extend from these arteries and supply most of the cortex, especially the motor and somatosensory cortical areas. The anterior cerebral artery supplies motor and sensory neurons responsible for the legs; the middle cerebral artery supplies the basal ganglia and internal capsule.

The vertebral arteries are found in the back of the head. These join at the pons to form the basilar artery, which sends off branches to the medulla oblongata, the pons, the mesencephalon and the cerebellum. The basilar artery bifurcates at the top of the pons to form the posterior cerebral arteries. These supply the visual cortex and inferior temporal lobe with blood. The middle cerebral arteries and the posterior cerebral arteries are connected on the left and right side by another artery, called the posterior communicating artery. There is also a communicating artery between the anterior cerebral arteries. These three communicating arteries form a circle of arteries called the circle of Willis.

Figure 3.16 Arteries of the brain (from Brodal 1992)

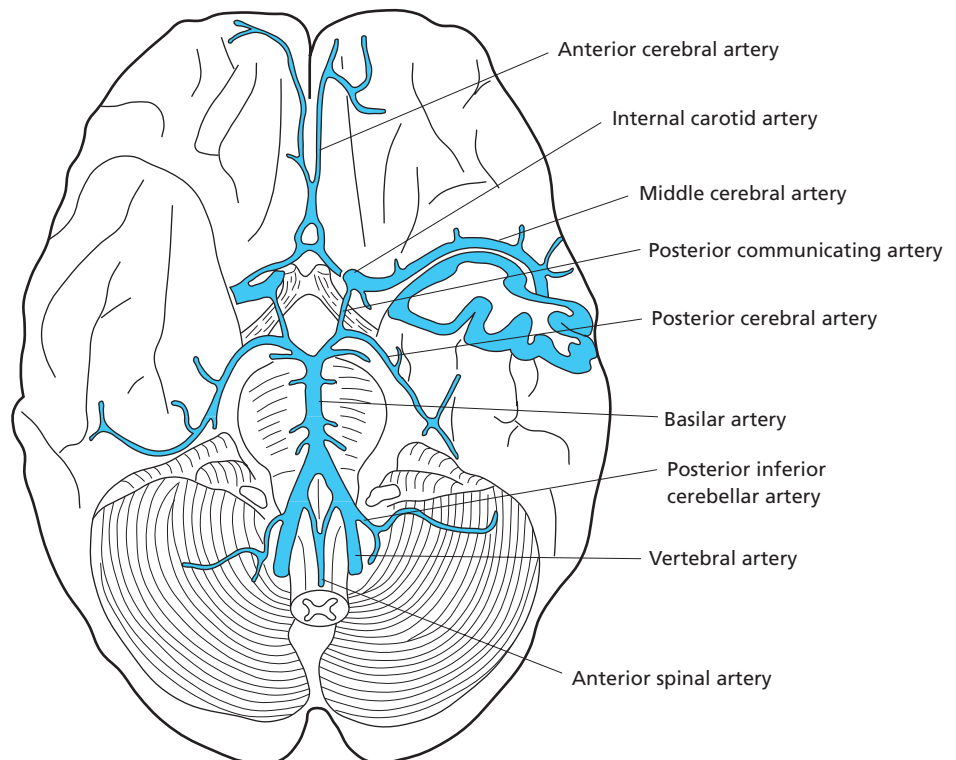
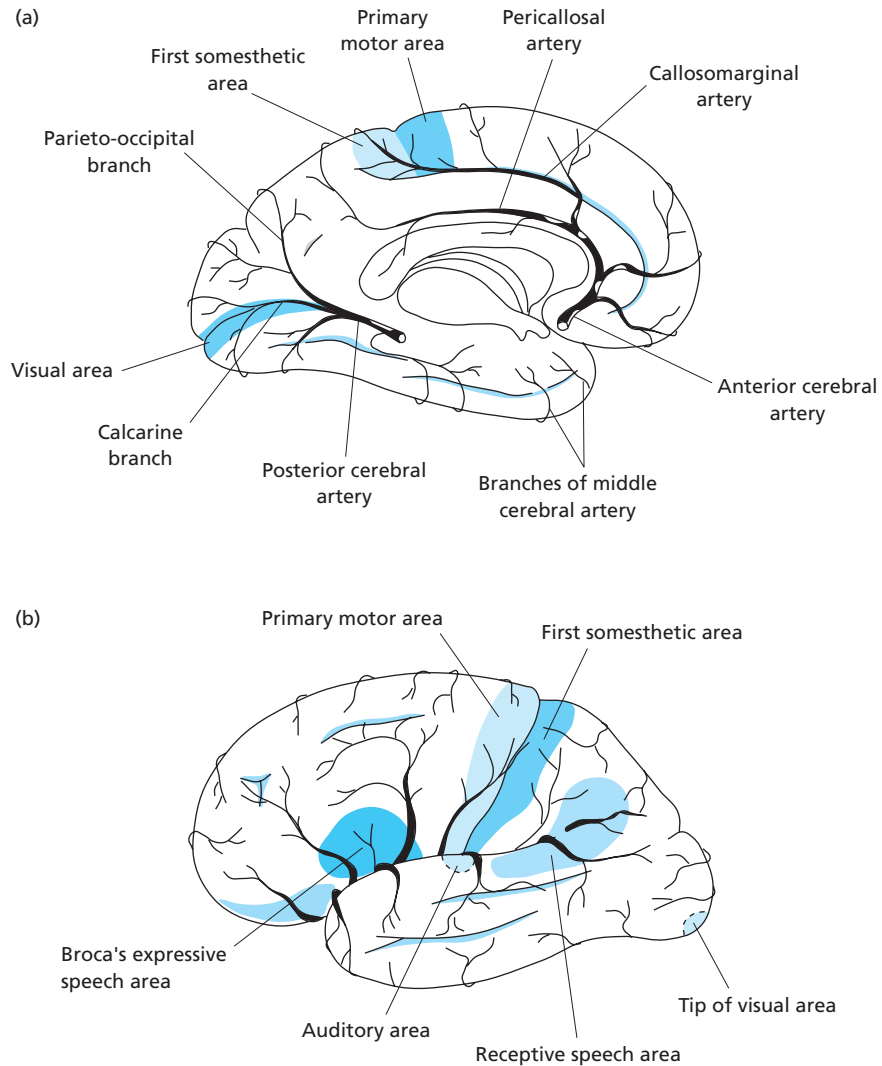

Figure 3.17

(a) Lateral distribution of the middle cerebral artery; (b) medial distribution of the anterior and posterior cerebral arteries (from Barr, M.L. and Kiernan, J.A., *The Human Nervous System*, fifth edition, © Lippincott, Williams & Wilkins (1988))



The spinal cord is served by an anterior spinal artery, which runs along the cord's midline, and posterior spinal arteries, which run along its side. The spinal arteries begin as branches of the vertebral arteries.

The brain also manifests deep and superficial veins, which empty into folds in the dura mater called venous sinuses. Veins from the subarachnoid space to the venous sinuses are called bridging veins. These are important because, if torn, the damage will result in bleeding between the dura mater and arachnoid mater in the subdural space. This is called a subdural haematoma. Unlike bleeding in the subarachnoid space, which flows along all the space, bleeding in the subdural space is fairly localized and does not spread. It may be possible, therefore, to predict which functions are likely to be disrupted based on the localization of the haematoma.

Malfunctions of the brain

One of the commonest sources of information in human neuropsychology comes in the form of damage or injury to the brain. The effects of tumour (or its removal), stroke, haemorrhage and other trauma indicate the extent to which the malfunctions of the brain can help to highlight how the organ normally functions. Some of the commonest forms of brain malfunction and their mechanisms are described below.

Closed-head injury

Closed-head injury describes an insult to the head that does not penetrate the skull or any of the meninges. This type of injury has primary consequences, such as bleeding or swelling of the brain or damage to the brain's surface following impact with the skull; it also has secondary effects, such as cell death. This type of injury contrasts with penetrating head injury, which, as its name suggests, involves penetration of the skull and/or meninges.

Cerebral oedema

An oedema (or edema) is a swelling of part of the brain and its surrounding tissue. There are three types: vasogenic, cytotoxic and interstitial.

Infarction

An infarction is any area of dead tissue resulting from a loss of blood supply.

Ischaemia

Ischaemia describes the loss of blood flow to the brain due to a narrowing or blockage of an artery. Complete blockage can result in an infarction as well as a confused mental state, memory decline and intellectual deficits. If there are episodic attacks of ischaemia, the disorder is called a transient ischaemic attack.

Thrombosis

Thrombosis describes the blockage of a blood vessel caused by coagulated blood. There may be an itinerant form of thrombosis that travels down narrow arteries, thereby plugging them. This blockage is called an embolism and can cause stroke. Embolisms need not always be coagulated blood: they can also be pockets of air, fatty tissue or hardened tissue.

Cerebrovascular accident/stroke

A cerebrovascular accident describes a sudden loss of blood supply to the brain. The commonest form of this is stroke, the effects of which depend on which artery is involved. For example, the middle cerebral artery, which supplies about 70 percent of the cortex with

blood, supplies many important areas, including Broca's area, Wernicke's area, the pre- and postcentral gyri, and the temporal and parietal lobes. Thus deficits might involve weakness, sensory loss and paralysis of the face and arm contralateral to the side of the artery involved. Recovery from stroke may depend on several factors, including the age of the individual, the site of the damage and a previous history of cerebrovascular accident.

There are two main types of stroke. Ischaemic strokes result from a reduction in blood supply, causing a lack of oxygen and glucose. They are usually caused by atherosclerosis, i.e. a blockage caused by deposits of cholesterol or other materials attached to the artery wall. Haemorrhagic strokes result from bleeding into brain tissue (intracerebral haemorrhage) or its surface (subdural haemorrhage). These result from three possible problems:

1. *A ruptured aneurysm*. An aneurysm is the ballooning of an artery wall, usually the walls of the circle of Willis in its anterior half. If an aneurysm ruptures, it can cause bleeding that is life-threatening. Alternatively, it may not rupture but could displace part of the cortex near to it or may contain stagnant blood.
2. *Arteriovenous malformation (angioma)*. This is a collection of abnormal blood vessels that produces abnormal blood supply. It is most commonly found in the middle cerebral artery.
3. *Hypertension*. This describes an increase in blood pressure due to the constriction of small blood vessels.

An MRI scan of a person who has suffered a CVA can be seen in Plate 3.1.

Haemorrhage (subarachnoid)

A subarachnoid haemorrhage describes the bleeding into the subarachnoid space and usually results from a ruptured aneurysm. Less commonly, it is caused by an arteriovenous malformation. Symptoms of this type of haemorrhage include explosive headaches followed by an almost immediate loss of consciousness. When loss of consciousness does not occur, the headache may be accompanied by nausea, vomiting, neck stiffness or fever. Around 40 percent of the aneurysms giving rise to haemorrhage are formed in the internal carotid artery, 35 percent in the anterior cerebral artery, 20 percent in the middle cerebral artery and 5 percent in the posterior or vertebral–basilar artery. Sometimes, there may be a danger that a haemorrhage will recur. The most likely period in which this would happen would be one to two weeks after the initial haemorrhage.

Tumour (intracranial)

A tumour is a space-occupying lesion of the brain and surrounding tissue. It comes in many forms, and its effects depend on factors such as speed of growth, the degree of pressure it causes and the cortex it displaces. Slower-growing tumours may go unnoticed for some time, and it is these that are less likely to have a dramatically harmful effect on intellectual ability and behaviour. Tumours can be invasive, where they invade the neural tissue, or non-invasive, where they invade supporting tissue, meninges or blood vessels. The pressure they exert can cause regions to be displaced, causing compression of some areas. Symptoms of pressure inside the skull include headache, sickness and disturbed consciousness. There are several types of tumour; the names of the following indicate where the lesion occurs: astrocytoma, glioma, haematoma, meningioma, angioma/hemangioblastoma (tumour of the blood vessels) and adenoma (tumour of the pituitary gland). Surgery is the most common and most effective form of treatment.

Anoxia

Anoxia refers to the loss of oxygen in the blood supplying the brain. A partial loss in this supply is called hypoxia. There can be many causes of anoxia, including suffocation (mechanical, or gaseous such as from carbon monoxide fumes), strangulation, partial drowning and exposure to high altitudes. The brain, being extremely sensitive to lack of oxygen, can malfunction severely with prolonged oxygen loss. This can produce cell death in all layers of the cortex and in the cerebellum.

Encephalopathy

Encephalopathy describes inflammation of the central nervous system caused by reaction to chemical, toxic or physical agents. It sometimes affects boxers – the pyramidal, extrapyramidal and cerebellar malfunctions and the dementia make individuals look ‘punch drunk’. In the severest cases, it results in coma and death.

Encephalitis

Encephalitis is inflammation of the brain and results from the cells of immune tissues, fluid and protein moving out of the blood vessels. At the turn of the century, it used to be called ‘brain fever’, and there is still controversy over the use of the term when applied to specific conditions. Inflammation due to bacterial infection around a brain abscess is called cerebritis. An inflamed spinal cord is called encephalomyelitis. Inflammation involving the grey matter of the brain is called polioencephalitis. Viruses can sometimes cause inflammation of the brain and often result in patient fatigue. However, myalgic encephalomyelitis (ME), also disparagingly known as ‘yuppie flu’, does not involve brain inflammation.

Hydrocephalus

Hydrocephalus describes the increase in the volume of the cerebral ventricles owing to overproduction of cerebrospinal fluid or blockage of the absorption of fluid by the ventricles. The dilation (enlargement) of the ventricles is called ventriculomegaly. The increase in volume causes pressure on the walls of the ventricles, especially the periventricular region. Adult and childhood conditions have different causes.

Headache

This commonplace symptom, usually taking the form of a dull throbbing pain in the head, can be an indicator of a more serious underlying condition if it persists. Headaches of abrupt onset can indicate subdural bleeding, especially if a stiff neck and vomiting accompany them.

If a headache is continuous, it may indicate a tumour. The pain is described as ‘bursting’ and may help to localize the tumour, because there are pain receptors in the blood vessels and dura. The ‘cluster headache’ is normally caused by migraine and involves recurrent attacks. It is also known as migrainous neuralgia and tends to be unilateral.

Sensory and motor systems

Many of the most unusual and peculiar functional phenomena seen by neuropsychologists are observed following impairment of the sensory, perceptual or motor systems (see Chapters 6 and 7). An understanding of these deficits requires a fairly sound knowledge of each type of system: sensory and motor. In what follows, the central and peripheral motor systems, together with the visual, auditory, somatosensory, olfactory and gustatory systems are described.

Visual system

The sense that we rely on and prize the most is vision. In evolutionary terms, this sense has become our dominant means of perceiving the world, a status that has probably evolved from our ancestors' ability to raise themselves from the ground and walk on their hindlegs. The reliance on the sense of vision is thought to be one reason why the sense of smell is no longer as important to human beings as it used to be thousands of years ago. Vision is indeed a powerful usurper. Given its importance, it is not surprising that studies of the neuropsychology of the senses have been dominated by vision research. This section reviews what we currently understand of the neurophysiology and neuroanatomy of the visual system and describes some of the consequences of damage to this system.

The eye and beyond

The initial structure for sensing the visual environment is the eye. The eye contains the retina, which itself contains certain cells important for the relay of visual information. These cells are called ganglion cells, made up of W, X and Y cells. These cells are categorized by size, the areas they project to and the function they serve. W cells have small cell bodies and comprise about 10 percent of retinal cells; X cells have medium-sized cell bodies and comprise 80 percent of retinal cells, and Y cells have large cell bodies and comprise the final 10 percent of cells. Y cells appear to respond to large, moving objects in the visual environment and appear to be involved in the analysis of crude forms and in directing attention to moving objects. X cells, in contrast, respond better to small targets and appear to be involved in the analysis of detailed, high-resolution and colour images. This arrangement illustrates one principle of visual system functioning: that it is involved in the parallel processing of stimuli; one type of cell responds to moving images, another responds to colour, another responds to size and so on, simultaneously.

The cells of the retina have a specific property called a receptive field, which is an area in which stimulation causes excitation or inhibition. Different parts of the eye have cells with different sizes of receptive field. For example, the receptive fields are larger in the peripheral parts of the retina than in the fovea. The fields also have two types of cell. The on-centre cells have a central excitatory area and an inhibitory surround, whereas the off-centre cells have an excitatory surround and an inhibitory centre. These cells are important because they can detect and appreciate contrasts in the visual environment.

All retinal cells project to the optic disc at the back of the eye, where they become myelinated and join other axons to form the optic nerve. Eventually, the optic nerve of each eye converges at a point called the optic chiasm.

When we see, we see from two visual fields: the right and the left. Visual fields are the areas in which the external world is viewed by the eye without the head moving. The right

visual field contains light that is sensed predominantly by the right eye; conversely, the light in the left visual field is sensed primarily by the left eye. Light that goes directly to both eyes (from the middle of the visual fields) occupies the binocular zone; light reaching only one eye occupies the monocular zone. A term used with regard to visual fields is 'hemiretina'. The part of the retina that is medial to the fovea is called the nasal hemiretina; the hemiretina lateral to the fovea is called the temporal hemiretina, as seen in Figure 3.18. Each half of the hemiretina is divided into dorsal and ventral parts.

The superior half of the visual field projects to the inferior half of the retina; similarly, the inferior half of the visual field projects to the superior half of the retina. This arrangement is dealt with by the brain to enable us to see normally. Light that occupies the binocular zones goes to both retinas: light falls on the temporal hemiretina of the left eye and the nasal hemiretina of the right eye. Only the fibres from the nasal hemiretina of each retina cross at the optic chiasm; the fibres from the temporal hemiretina do not. Fibres that exit the optic tract project to the lateral geniculate nucleus of the thalamus, an important relay station in the visual system. From here, axons are sent to the visual cortex.

Figure 3.18

Monocular and binocular zones of the visual fields (from Kandel, E.R. *et al.*, *Essentials of Neural Science and Behaviour*, © 1995, McGraw-Hill/Appleton & Large, reproduced with permission of The McGraw-Hill Companies)

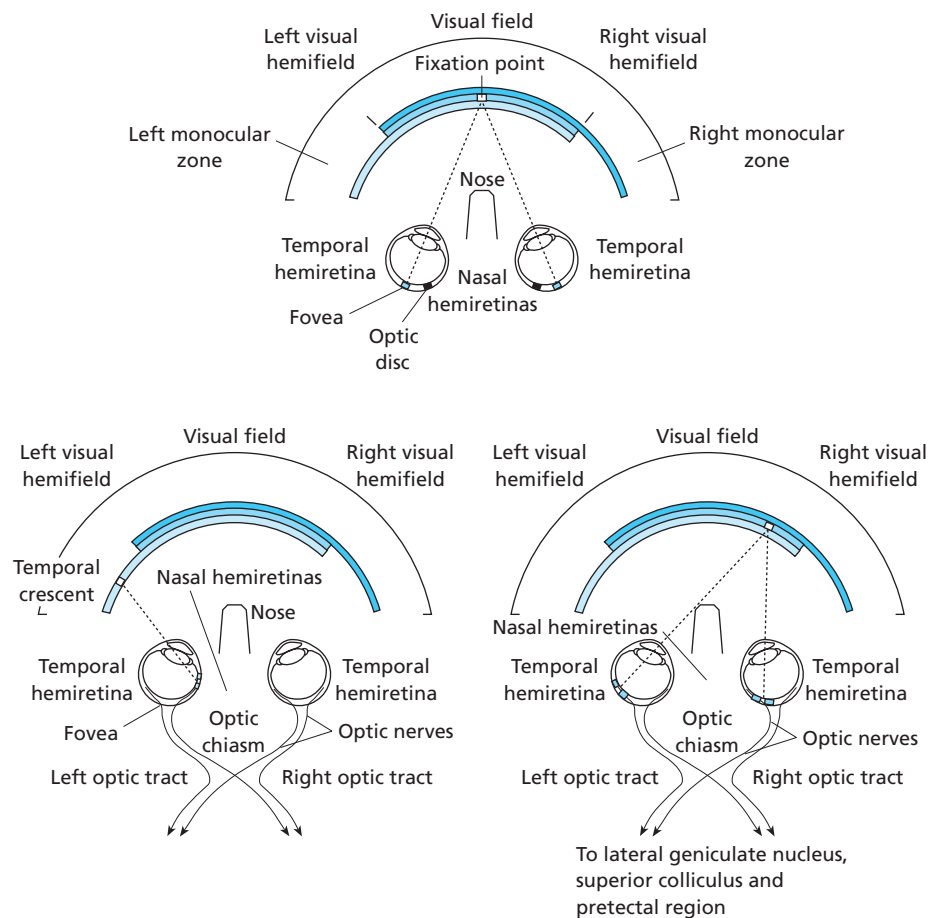

Light that occupies monocular zones projects to the nasal hemiretina on the same side as the light (the nose prevents light from reaching the other eye). The monocular area of the visual field is called the temporal crescent. Light from this region cannot be sensed binocularly.

Lateral geniculate nucleus

The lateral geniculate nucleus (LGN) is found in the posterior thalamus and is important for a number of reasons, not least because the optic tract fibres terminate here and because different axons terminate in specific areas of the LGN. Greater input is provided from central than from peripheral lines of vision from the retina. In the primate, the LGN has six layers of neurons separated by axons and dendrites. Each layer receives information from one eye only: the contralateral nasal hemiretina projects to layers 6, 4 and 1; the ipsilateral temporal hemiretina projects to layers 5, 3 and 2 (see Figure 3.19).

Layers 1 and 2 (the most ventral layers) are called magnocellular layers because they contain large cells. Layers 3 to 6 (the most dorsal layers) are called parvocellular layers. Y cells project to the magnocellular layer; X cells to the parvocellular layer. Because of this

Figure 3.19

Pathway from the visual field to the brain (from Kandel, E.R. *et al.*, *Essentials of Neural Science and Behaviour*, © 1995, McGraw-Hill/Appleton & Large, reproduced with permission of The McGraw-Hill Companies)

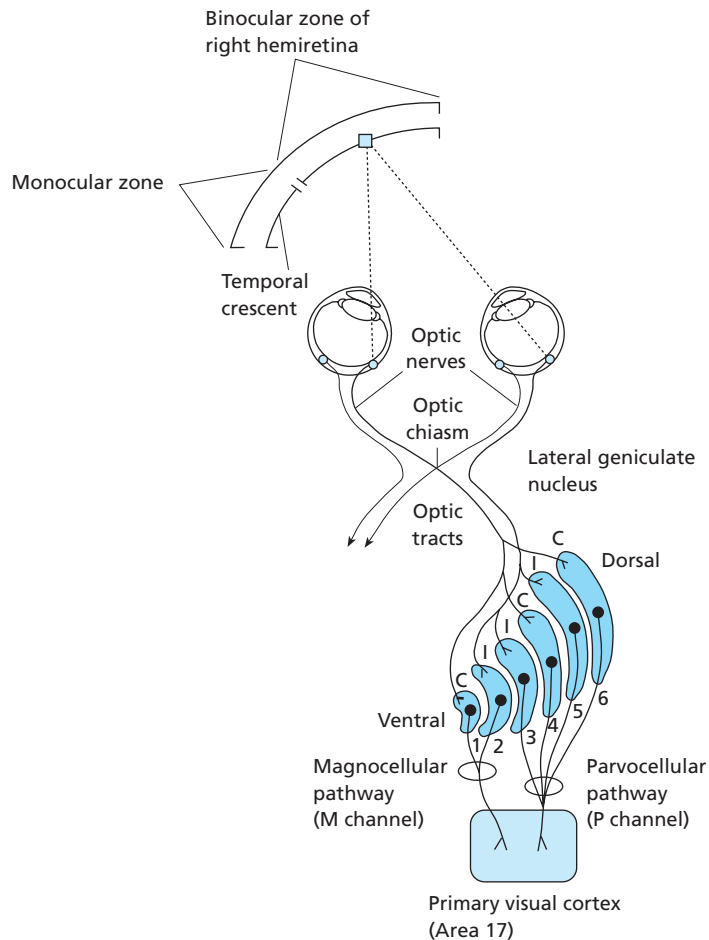
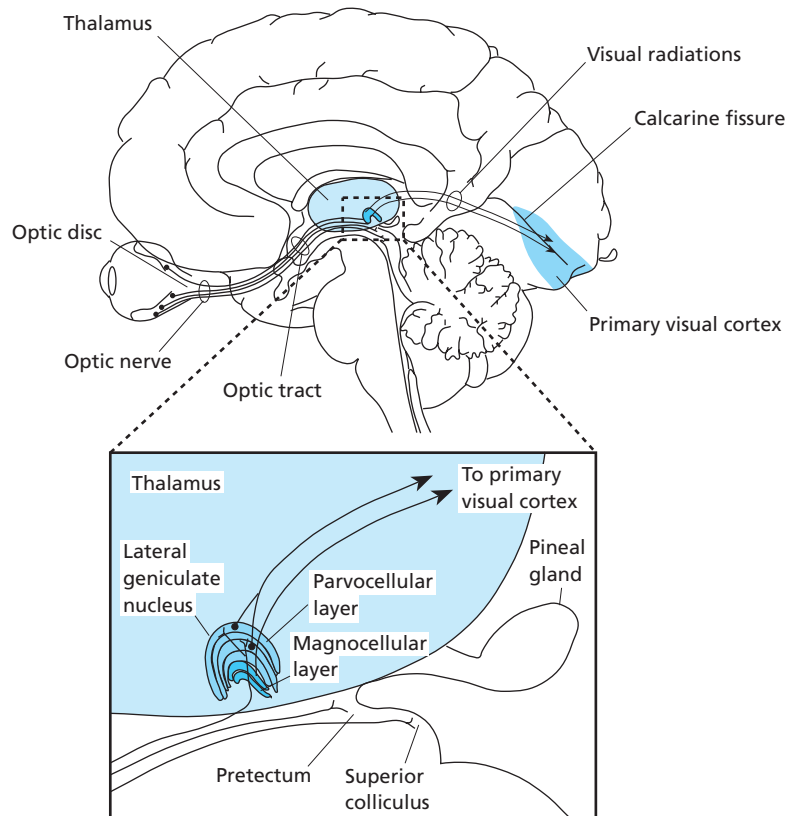

Figure 3.20

Parvocellular and magnocellular visual fields (from Kandel, E.R. *et al.*, *Essentials of Neural Science and Behaviour*, © 1995, McGraw-Hill/Appleton & Large, reproduced with permission of The McGraw-Hill Companies)



projection pattern, the pathways are called X-parvocellular and Y-magnocellular. These pathways are illustrated in Figure 3.20.

All the cells project to the visual cortex. However, retinal cells also project to the superior colliculus, a structure that is important for the control of eye movement. The types of ganglion cell found in these structures differ. X cells project only to the LGN; Y cells project to those layers of the LGN not receiving X axons and to the superior colliculus; W cells project primarily to the superior colliculus.

Superior colliculus and pretectum

Like the LGN, the superior colliculus has several layers and receives visual input from the retina. Its superficial layers receive visual input; its deepest layers receive somatic, sensory and auditory input. However, the primary function of the superior colliculus appears to be orienting the head and eyes towards a visual stimulus and the control of rapid eye movements (called saccades). The guidance of the head is done in association with the frontal eye fields of the frontal cortex, which receives information from the visual cortex via X cells. The superior colliculus, via the Y cells, is also concerned with movement, visual attention and identifying broad visual outlines. There are also tectopontine axons (superior colliculus axons synapsing in the pontine nuclei), which help to relay visual information to the cerebellum.

The pretectum mediates pupillary light reflexes. Light that is picked up by retinal cells stimulates axons that project from the optic nerve to the pretectum, which lies rostral to the superior colliculus. The pupillary reflex is an important one, because its absence indicates substantial midbrain damage. The reflex usually takes the form of a direct and consensual response. The former describes the constriction of the pupil following light shone directly onto the eye; the latter describes constriction occurring in the other eye at the same time (although it is not directly stimulated).

Damage to the visual pathway

Certain deficits in vision can occur with lesions to the visual pathway. For example, if the optic nerve is lesioned, vision functions only in the intact eye (monocular blindness). Damage to the optic nerve can also result in blindness in the temporal crescent on the lesioned side. Damage to the fibres crossing the optic chiasm results in a bilateral hemianopia: a loss of vision in the temporal parts of both visual fields. A complete homonymous hemianopia can result from a lesion to one optic tract. When this occurs, there is complete loss of vision in the contralateral visual field. Quadrantic anopia occurs when there is partial loss of vision in one visual field. Sometimes, individuals develop 'blind spots' (scotomas), which result from isolated lesions of the primary visual cortex. Individuals are aware of what they see and are capable of responding to stimuli, because involuntary eye movements are made that cover these blind spots (this is called nystagmus). When the eyes move about, the scotoma also moves about. More information in the visual fields thus reaches the brain. However, if the patient stays still and an object is placed directly in front of the scotoma, that object cannot be seen.

Cortical blindness refers to loss of vision following damage to the primary visual cortex. It results in the inability to distinguish forms and patterns while remaining responsive to light and dark. It has been argued that visual discrimination takes place at the thalamic level, while the cortex is necessary for the conscious experience of visual stimuli (Hecaen and Albert 1978). In fact, total blindness requires some destruction of the thalamus and the visual cortex and its afferent pathways (Teuber 1975). In denial of blindness (visual anosagnosia or Anton's syndrome), patients do not acknowledge that they are blind and behave as if sighted. Corticothalamic connections are thought to be disrupted here, as are sensory feedback loops.

Primary visual cortex

The primary visual cortex (PVC) is located in the occipital lobe and is also referred to as the striate cortex. It corresponds to Brodmann's area 17. It was given the name striate because it contains a distinctive stripe of white matter called the stria of Genari. The appearance of matter is the result of termination of myelinated axons from the LGN in layer IV. The PVC receives axons, called the optic radiation, from the LGN and is about 3 mm thick. It is layered, with alternating layers performing different functions. Axons from the LGN terminate in layer IV. In a series of innovative experiments, Hubel and Wiesel (1979) discovered that layer IV was made up of three separate layers (IVa, b and c; IVc can be further subdivided into IVc and IVc). Layer IVc receives input from one or other eye from different layers of the LGN; the output from layer IVc goes to the larger layers above and below it. Layer IVc neurons also send axons to layers II and III, which in turn connect to layer V. Layer V itself projects to layer VI. Each layer projects to different parts of the cortex. For example, axons from layers II and III project to the medial temporal lobe of area 18 (the area of higher visual function); layer V projects to the superior colliculus. Layer VI projects back to the LGN, thus providing the visual system with a feedback loop.

The PVC receives information only from the contralateral hemifield. Information can also be sent to the higher visual function areas, or extrastriate cortex (area 18), which can send information to the medial temporal cortex (area 19), inferotemporal cortex (areas 20 and 21) and posterior parietal cortex (area 7). In a series of pioneering studies involving primates, Zeki (1993) has argued that area 17 sends four separate projections to area 18. These four parallel systems represent colour, motion and form (which has two systems). One X pathway projects from the PVC (V1) to area V2, then V3 and V3a, V4 and the inferotemporal cortex. This system is involved in the perception of form and colour. Y cells project from the PVC to V2 and V3 and then to V5 and the posterior parietal cortex. This may be involved in the perception of movement.

The massive complexity of this arrangement has to accommodate visual responses from the lowest level (e.g. the retina's response to brightness) to the highest level (e.g. abstracting information and ascribing meaning to the visual images perceived as well as being able to act on what is seen). Lesions to V4 result in achromatopsia (colour blindness), in which the world is perceived in shades of grey. Damage to V5 results in akinetopsia: the patient cannot see or understand the world in motion. Curiously, when objects are still, they can be seen clearly; when they are moved, they appear to disappear. This occurs even when motion is actually illusory.

One theory of visual system function argues that two distinct cortical pathways are responsible for the processing and analysis of different types of visual information. The 'dorsal' stream is involved in the analysis of spatial relations; the 'ventral' stream is involved in the recognition of objects. Two specific cellular pathways – the parvocellular and magnocellular pathways – run from the retina to the cortex and terminate in different layers, called 4C β and 4C α respectively, of the primary visual cortex (V1). Other layers of V1 project to other dorsal and ventral stream areas. Layers 2 and 3 of V1, for example, provide input to the ventral stream areas, whereas layer 4B sends input to dorsal stream areas. Layer 4B also receives input from the M and P pathways and projects to areas such as V5, a region known to be involved in motion perception. Many other circuits such as this are made within the visual system, but comparatively little is known about how functionally relevant such connections are or how different types of cell contribute to the circuitry.

One study has shown that different types of neuron in area V1 receive different signals from the M and P pathways and forward this information to other specific cortical areas (Yabuta *et al.* 2001). The study measured sources of excitatory input to neurons in layer 4B of V1 in the macaque monkey. In layer 4B, one type of cell (spiny stellate cells) received input from the M pathway via layer 4C α and no strong input from the P pathway through layer 4C β . Another type of cell in layer 4B (called pyramidal cells) received input from both the alpha and beta layers. The results of the study suggest that if two types of cell project to different layers, perhaps each type carries different types of information in the cortical visual system.

Theories of visual system functioning

The dissociable effects of damage to the visual system indicate that certain visual system pathways may be more influential in processing certain types of visual information than others. In 1969, Schneider proposed that visual system functioning was served by two major pathways (Schneider 1969). One, the geniculostriate pathway, was responsible for the organism's ability to identify stimuli and discriminate between patterns. The other, the retinotectal pathway, was responsible for the organism's ability to locate objects in space. Currently, a similar distinction is made in neuropsychology, although the specific proposals of Schneider have been challenged and modified.

However, what appears to be clear is that object location and identification are dissociable. For example, Ungerleider and Mishkin (1982) have proposed that the visual processing involved in the appreciation of an object's qualities is subserved by the inferior temporal cortex, whereas knowledge of spatial location is subserved by the posterior parietal cortex. Furthermore, Ungerleider and Mishkin proposed that these two cortices received independent projections from the striate cortex: the 'ventral stream' projected to the inferotemporal cortex; the 'dorsal stream' projected to the posterior parietal cortex. Lesions to these cortices in experimental animals resulted in object identification and object location difficulties, respectively. The location of the two pathways can be seen in Figure 3.21.

Goodale and Milner (1992) have developed the two visual systems theory of visual function in a slightly different direction. Instead of focusing on the input aspect of visual processing, they have proposed a theory of visuomotor function based on the output requirements of the visual system. That is, they suggest that the important distinction is between 'what' and 'how', not 'what' and 'where'. Implicit in this assumption is the notion that parts of the visual system can be put to different uses – specifically, to allow guided grasping and reaching. Before examining Goodale and Milner's hypothesis more closely, it is important to consider some background to parietal cortex damage and visuospatial movement. For example, lesions to the superior parietal cortex can lead to impairments in visually directed reaching movement. This is called optic ataxia and is characterized by inaccurate movements and an erring of movement in the direction ipsilateral to the side of the lesion (Jeannerod 1986; Perenin and Vighetto 1988). The duration of the movements is longer in these patients, and velocity of movement is reduced. Commonly, it is found that patients cannot guide their hand to a slit in an object and are sometimes impaired at grasping and manipulating objects (Perenin and Vighetto 1988).

Patients with Balint's syndrome (Balint 1909) also show bilateral lesions of the inferior parietal cortex. While rare, the disorder is characterized by three principal symptoms: (1) neglect of the left visual field and parts of the right, with attentional gaze directed 35 or 40 degrees to the right; (2) inattention to other objects when the object in the field of vision has been detected; and (3) difficulty in reading under guidance (Jakobson *et al.* 1991). Apart from these visuospatial impairments, patients do not exhibit cognitive or visual defects.

Figure 3.21

The two visual routes (dorsal and ventral) in the primary visual cortex (from Pinel, John P. J. *Biopsychology*, 3rd edition. Published by Allyn and Bacon, Boston MA. Copyright © 1997 by Pearson Education. Reprinted by permission of the publisher)

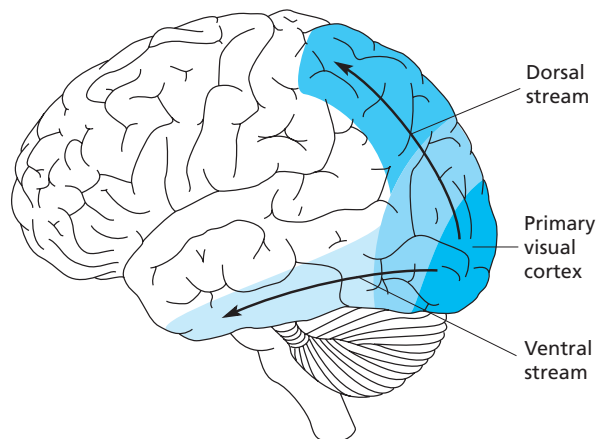

As these disorders suggest, the most common behavioural deficits following parietal lobe lesions are difficulties in visuospatial performance. Patients have difficulty perceiving horizontal and vertical axes and in perceiving length, distance and orientation (Von Cramon and Kerkoff 1993), although they can recognize objects. Jeannerod and colleagues' patient, AT, for example, presented with large bilateral occipitoparietal infarction, which produced not only optic ataxia but also a severe inability to estimate length of lines and the size of drawn figures (Jeannerod *et al.* 1994). AT's ability to reach was fairly normal, but the ability to grasp, especially the ability to grasp small objects, was impaired.

An interesting and associated case was presented by Goodale and his colleagues (Goodale *et al.* 1994). Patient RV also suffered bilateral occipitoparietal damage, but whereas both RV and AT had damage to areas 18 and 19, only AT had damage to areas 7 and 39, the parietal areas. Reaching is also fairly normal in RV and grasping is poor, but unlike AT, the ability to compare shapes is unimpaired. Jeannerod (1997) has interpreted this dissociation following parietal lobe lesions as reflecting a view of brain function in which object-oriented responses are distributed in two cortical visual systems. Dorsal damage results in grasping impairments; ventral damage results in impairments in judging the size of objects.

Based on their and others' data, Goodale and Milner suggested a dual system for the processing of the form of objects in the ventral system (Goodale and Milner 1992; Milner and Goodale 1993), with the dorsal system having a greater role in vision: it mediates visuomotor transformation, which allows goal-directed action. Their patient, DF, had suffered a large bilateral occipital lesion destroying areas 18 and 19 but sparing most of area 17 (Goodale *et al.* 1991). Perception of simple forms was quite poor – she performed at chance levels – and the perception of motion was also poor. However, she was able to guide her hands and fingers quite accurately in the directions of the objects she failed to recognize. When presented with similar or different rectangular blocks, she was unable to discriminate between them, even by indicating their width using her index finger and thumb. When asked to pick up one of the blocks, however, she was able to adjust her fingers accordingly and accurately. A similar dissociation was seen when she had to orient her hand (or describe the orientation of her hand) in the direction of a large slot. When she had to guide her hand through the slot, however, she performed as normal, adjusting her hand to match the orientation of the slot before reaching it.

Goodale and Milner suggest that because other cases of parietal lobe damage show the opposite pattern – patients may recognize objects but are poor at guidance – and because temporal lobe damage is associated with aspects of visuospatial processing, the visual projection system to the parietal cortex represents information about object characteristics and orientation that are related to movement. This represents the dorsal stream. They suggest that disruption to the projections to the inferotemporal cortex may be responsible for the deficits seen in DF. This disruption occurs in the ventral stream.

Detection by action: the case of MP

It is a given – ostensibly, an obvious one – that visual search involves the detection of a target and that this detection involves an awareness of the object's features. For example, if we wish to look for a cheese knife in a drawer full of cutlery, there are some schemata about a cheeseknife that will direct our search (its shape and colour, for example). Often this search is top-down – we have a template of the target to guide us.

Normally, this template is perceptual in nature – we detect by shape, colour, size, and so on. However, a recent case study suggests that we can do this without specifically attending to the perceptual features of objects.

Gibson has argued that some objects can ‘afford’ an action. For example, a fork can do the job of a cheeseknife because it can be held like a cheeseknife and can cut. Humphreys and Riddoch’s (2001) patient, MP, was able to use knowledge about the properties of an object, based on its use, to identify it but was unable to identify by name or perceptual feature.

MP was a left-handed tool-worker who suffered spatial neglect (a perceptual disorder in which patients are unable to attend to one half of the visual field, as Chapter 6 describes in more detail) following right fronto-temporal-parietal damage. When asked by the experimenter to identify objects by their physical or perceptual features (e.g. ‘find a red object’), MP was unable to do so. MP was similarly impaired at identifying objects when given their names (e.g. ‘find the red cup’). However, he noted that he was able to identify objects when he knew what to do with them.

To test this, Humphreys and Riddoch (2001) conducted six experiments in which MP was asked to identify objects under various experimental manipulations. For example, he would be presented with an array of ten objects with their handles pointed towards him and asked to identify one by either perceptual feature, name or function (e.g. ‘find an object you can drink from’). The location of MP’s lesions and examples of the stimuli used in the study can be seen in Figure 3.22.

In the abstract, MP could name colours and objects. He had difficulty in finding the same colours and objects in an explicit visual search task, especially when multiple objects competed for his attention. When cued by action, however, MP was able to do this. This dissociation was supported by two other patients who showed the opposite pattern to MP – they were able to use names to identify objects.

MP’s behaviour, according to Humphreys and Riddoch, suggests that we can use action templates to identify objects as well as perceptual templates, even if action templates mean that the visual search will be slower.

Figure 3.22

(a) The number of correct responses and (b) the reaction times made by Humphreys and Riddoch’s (2001) patient MP; (c) the area lesioned in MP and the other patients in the same study (from Humphreys and Riddoch 2001)

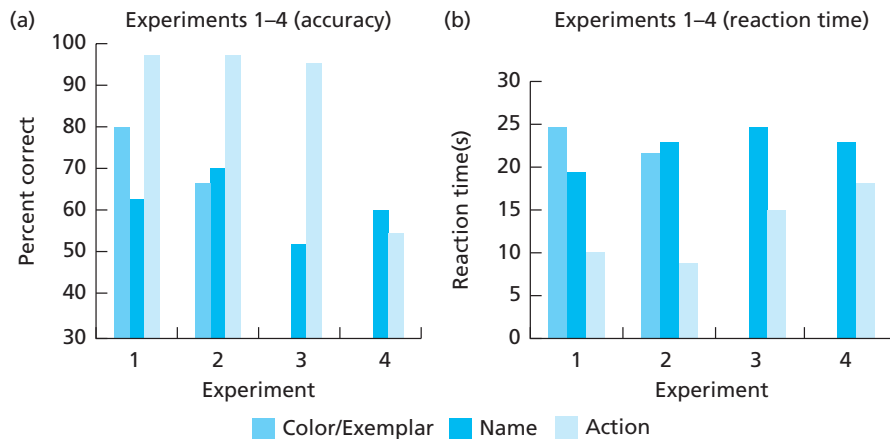
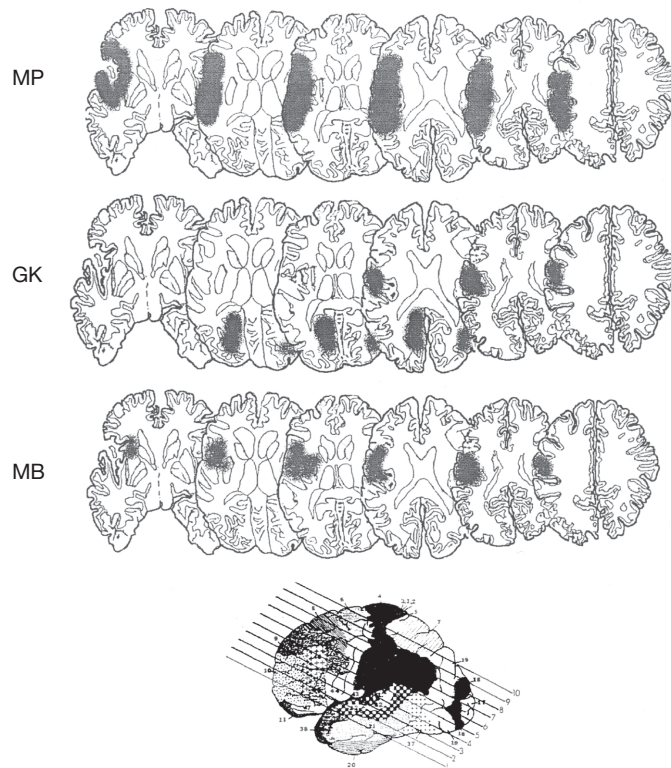

Figure 3.22

continued

Auditory system

Audition, like vision, is served by a number of distinct structures and neural pathways. A person with normal hearing will be able to detect a sound wave that is between 20 and 20 000 Hz although he or she will be most sensitive to sounds that are between 1000 and 4000 Hz. These sound waves travel through the air, reach the ear and stimulate the tympanic membrane (or eardrum). From this point, the impulse is transmitted via three ossicles (or bones) called the malleus, incus and stapes to the cochlea. The cochlea is part of a membranous labyrinth that includes the vestibular apparatus, which is characterized by three semicircular canals.

The part of the cochlea that is membranous is called the cochlear duct, which is about 3 cm long and forms a spiral-shaped structure. The lowest part of this duct is made up of the basilar membrane, on which rests the organ of Corti (see below). The top end is made up of the vestibular membrane. Outside the duct are two parallel canals: the scala tympani, situated below the basilar membrane, and the scala vestibuli, situated above the vestibular membrane. These tympani have windows or openings called fenestra vestibuli and fenestra cochleae, which are closed by different mechanisms. At the end of the scala vestibuli lies the oval window; at the end of the scala tympani lies the fenestra cochleae or round window.

Audition begins properly with sound waves reaching the external ear. This is called the external auditory meatus. Waves also reach the middle ear and tympanic membrane, which is found at the lower end of the auditory meatus. Connecting the eardrum with the oval windows are small bones. The malleus (or hammer) connects to the incus (or anvil), and the incus is connected to the stapes (or stirrup). These bones are important because they are sensitive to sound waves, which make them vibrate and thus transmit an impulse to the fluid in the cochlea. When the stapes are pressed into the oval window, the *scalae vestibuli* are closed and the fluid in them (called *perilymph*) is stimulated by movement from the sound wave that stimulated the stapes. The movement caused by the vibration is then transmitted to the fluid (called *endolymph*) in the auditory canal; the movement then travels on to the basilar membrane, which transmits an impulse to the fluid in the *scala tympani*. The movement of the basilar membrane stimulates receptors in the cochlea, which have sensory hairs called *stereocilia*. The inner and outer hair cells are separated by large supporting cells called *pillar cells*. Together these form the *tunnel of Corti*, which is part of the *organ of Corti*, the region where receptors are organized. One of the most interesting features of the basilar membrane is that different frequencies are required to stimulate it at different points along its length. The highest pitches are sensed by hair cells near the oval window (the bottom of the basilar membrane); the lowest pitches are sensed at the anterior part of the cochlea.

From the cochlea, the sound impulse is sent via part of the eighth cranial nerve called the *cochlear nerve*. These efferents reach a collection of structures called the *superior olivary complex* in the medulla. The superior olive itself is located in the pons (at the bottom end) in the *trapezoid body*. The *cochlear nuclei* form a pathway that reaches the *inferior colliculi*. This ascending pathway is called the *lateral lemniscus*. Other nuclei reach the *olivary complex*, which then project to the *inferior colliculi*. From the *inferior colliculi*, fibres are sent to the *medial geniculate body* of the *thalamus*. The efferents from this part of the *thalamus* thus finally terminate in specific areas of the *auditory cortex*, or *AI*. Like the visual system, there is some crossing of the pathways in the auditory system. Unlike the visual system, however, there are also a considerable number of *uncrossed fibres*. This means that *unilateral damage* to the auditory pathway may not result in obvious hearing impairment, because there are *uncrossed fibres* that still allow the transmission of auditory information. However, damage to the *cochlear nerve* does result in *deafness* in the ear *ipsilateral* to the lesion. The pathway of the auditory system is seen in Figure 3.23.

The core projection of the ascending pathway terminates in the *auditory cortex* and is so called because it reaches the core area of the cortex responsible for audition. The *belt projection* makes its way from the *peripheral inferior colliculi* to the areas surrounding *AI*, which are also responsive to other types of stimulus. The *belt projection* is so called because the projected fibres surround the *auditory cortex* like a belt. The auditory system also features *descending connections* from *AI* to the *thalamus* and *inferior colliculi*. The auditory pathways contain many *inhibitory interneurons*. Given the amount of auditory information that this system receives, this inhibition is perhaps not surprising and is certainly essential for allowing only the most relevant or *salient* information to be processed. Imagine how difficult it would otherwise be to attend to a single conversation in a crowded room of several noisy, chattering individuals and the importance of this inhibition becomes clear. However, the system not only allows *selective attention* to auditory information but also mediates *startle reflexes* (sudden, involuntary behavioural responses prompted by unexpected or loud auditory stimuli), which occur via the *reticular formation's* links with the *association auditory pathways*.

Figure 3.23

The auditory system (from Carlson, Neil, R. *Foundations of Physiological Psychology*, 3rd edition. Published by Allyn and Bacon, Boston, MA. Copyright © 1995 by Pearson Education. Reprinted by permission of the publisher)

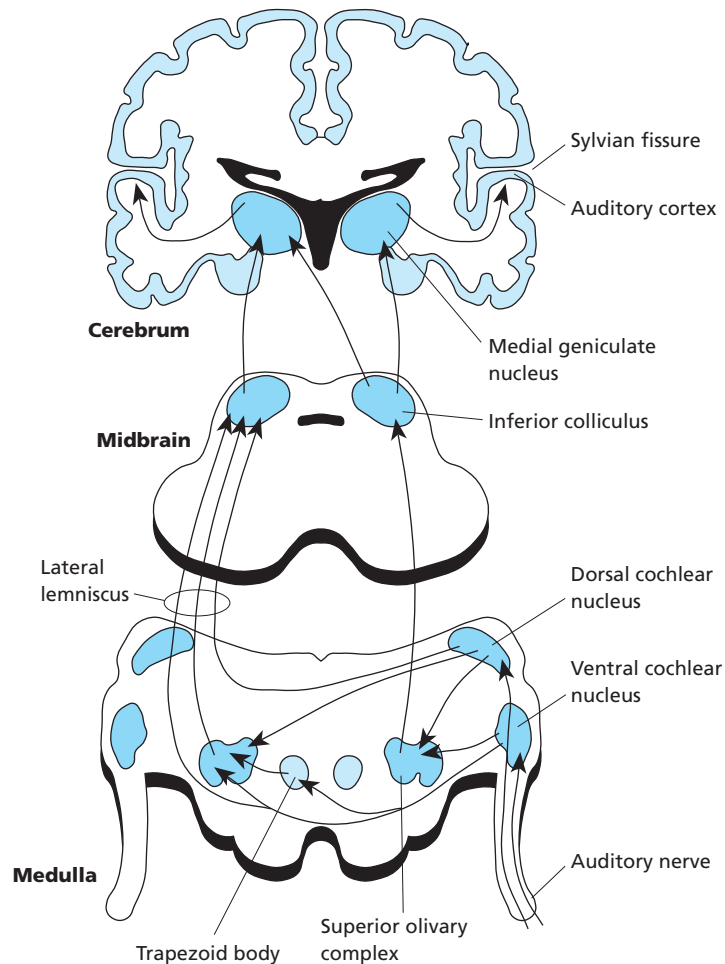

One of the key features of the visual system is that it is organized hierarchically at the neural level. That is, sensory input is broken down and then put together to form complex stimuli in various regions of the brain. This means that different regions of neurons are responsible for processing different types of visual stimulus. A similar phenomenon has also been demonstrated for the auditory sense – tones, non-speech stimuli, meaningless speech sounds and other types of auditory stimulus have been found to generate specific areas of the cortex, as well as areas they seem to have in common.

Wessinger *et al.* (2001) presented pure tones and complex auditory stimuli to twelve healthy right-handed men and women and used functional magnetic resonance imaging (fMRI) to monitor changes in brain activation. Pure tones were found to activate a core area – areas that surround Heschl's gyrus – but more complex stimuli activated areas outside this core (the pure tones did not). The authors propose that this hierarchical system of sound analysis participates in the early processing of many sounds, including those for speech.

A more conceptually complex study was undertaken by Lewis *et al.* (2004). They sought to discover whether the cortex responded to different categories of noise and to

determine the neural pathway responsible for environmental sound recognition (the ‘what’ of hearing). They used fMRI to record activation while healthy participants listened to the sounds made by tools, animals, liquids and dropped objects, plus other unrecognizable sounds. The recognizable sounds activated areas in the left hemisphere associated with semantic processing, as well as bilateral activation in the posterior middle temporal gyri. Lewis *et al.* suggest that this later region is a multi-modal processing area, i.e. one that may serve a similar function in more than one sense, because other studies of vision have reported activation in similar regions when people process complex movement and recognize tools and objects. This ‘action representation’ area may assist in identifying familiar environmental sounds, because it can assimilate knowledge about objects and their motion (such as the falling of a cup or the flapping of a bird’s wing).

Somatosensory system

The system that allows us to sense touch, to feel pain, to experience changes in temperature and to ascertain the position of limbs and other parts of the body (proprioception) is the somatosensory system, and all of these phenomena are described by the term ‘somatosensation’. In addition to sensing all the somatosensory input described above, this system also allows us to detect differences in pressure placed on the skin, the usual receptor site of the somatosensory system.

Tactile sensation for most somatosensory functions, except proprioception of the lower extremities and basic forms of tactile stimulation, is undertaken by the dorsal column–medial lemniscal system. Pain and crude tactile sensation, on the other hand, are mediated by the antero-lateral system. Receptors in the skin and subcutaneous tissue send afferents to the spinal cord via the dorsal roots. An axon branch ascends into the dorsal column and synapses in the medulla. Those axons of sensory cells in the dorsal column nuclei then project in the opposite direction. At the midline of the medulla, they cross and pass through the brainstem contralaterally, making synapses with cells in the ventral posterior lateral nucleus of the thalamus, as seen in Figure 3.24. From here, thalamic projections are sent to the cerebral cortex. This pathway is called the thalamocortical projection or radiation and runs through the internal capsule, terminating in the primary somatic sensory cortex (SI) or somatosensory cortex, which is found in the precentral gyrus of the parietal lobe. Thalamic fibres also project to nearby cortex called the secondary somatic sensory cortex (SII). SI and SII are distinct in that SI receives primarily contralateral input, whereas SII receives bilateral input.

Gustatory system

The gustatory system is one of the two most important sense organs for the perception of food flavour. Its receptors allow us to distinguish between at least four classes of taste: sourness, bitterness, sweetness and saltiness. There may also be a fifth taste called umami, which represents a savoury taste similar to monosodium glutamate. The external receptors for taste are the taste buds, which contain epithelial cells that are specialized taste receptors. Each taste bud contains 50–100 cells, and they are found principally on the tongue, although some are also found in the pharynx and palate. The taste buds are innervated by three cranial nerves – the seventh, ninth and tenth – each of which innervates a different collection of taste buds.

Figure 3.24

(a) The dorsal column–medial lemniscal system of the somatosensory system; (b) the somatosensory cortex (from Kandel, E.R. *et al.*, *Essentials of Neural Science and Behaviour*, © 1995, McGraw-Hill/Appleton & Large, reproduced with permission of The McGraw-Hill Companies)

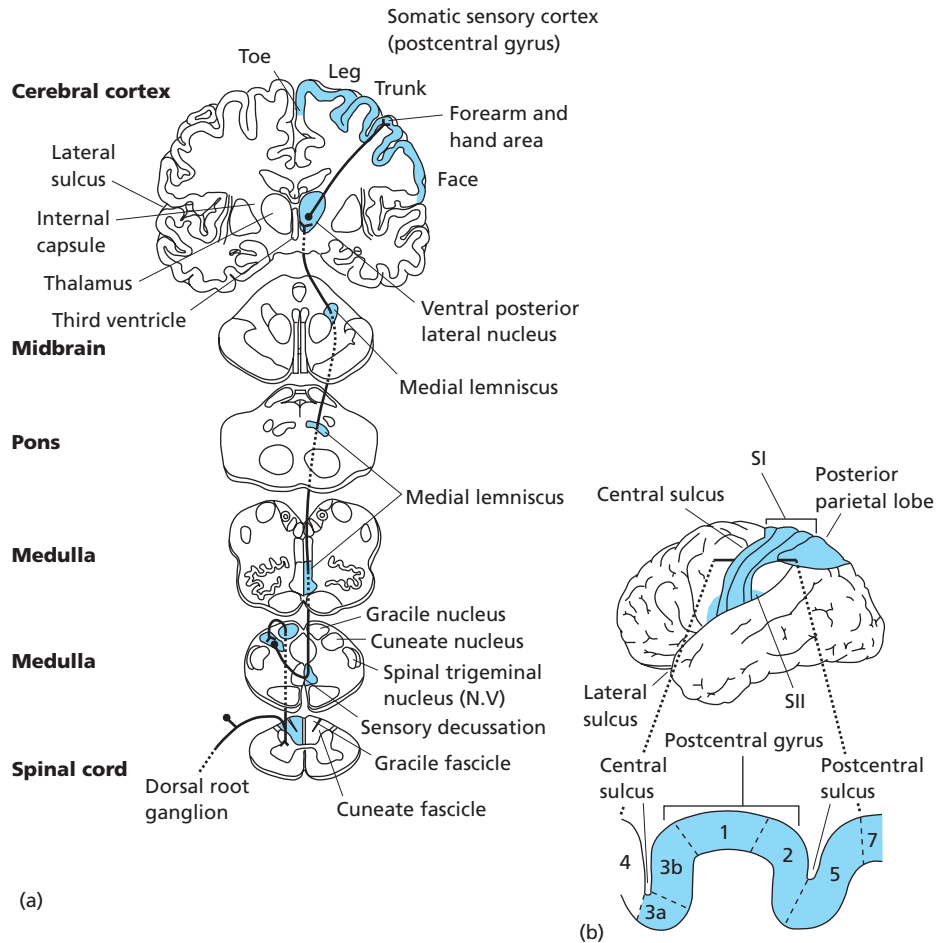

Second-order neurons are then projected to the parvocellular division of the ventroposteromedial thalamic nucleus, or the taste thalamus. Fibres from the taste thalamus project to the cortex, specifically the rostral frontal operculum and insula. These cortices comprise the primary taste cortex (Rolls 1989).

There may also be a secondary taste cortex in the caudolateral orbito-frontal cortex, which lies anterior to the primary taste cortex, as seen in Figure 3.25 (Rolls *et al.* 1989; Rolls and Baylis 1994). In a novel series of experiments, Rolls and Baylis found evidence to suggest that the orbitofrontal cortex acts as a form of convergence zone for chemosensation, because olfactory stimulation produces responses in its medial part, visual stimulation activates an area between the secondary taste cortex and the medial orbitofrontal cortex, and, as we have already seen, gustatory inputs stimulate the secondary taste cortex. This point is taken up in the chapter on the frontal lobes (Chapter 5).

The part of the brain described as the primary taste (gustatory) area is found near the front of the brain in regions called the insula or frontal operculum and further back in part

Figure 3.25

(a) The gustatory system, from tongue to brain (from Pinel, John P. J. *Biopsychology*, 3rd edition. Published by Allyn and Bacon, Boston MA. Copyright © 1997 by Pearson Education. Reprinted by permission of the publisher); (b) the primary and secondary taste areas in the cortex

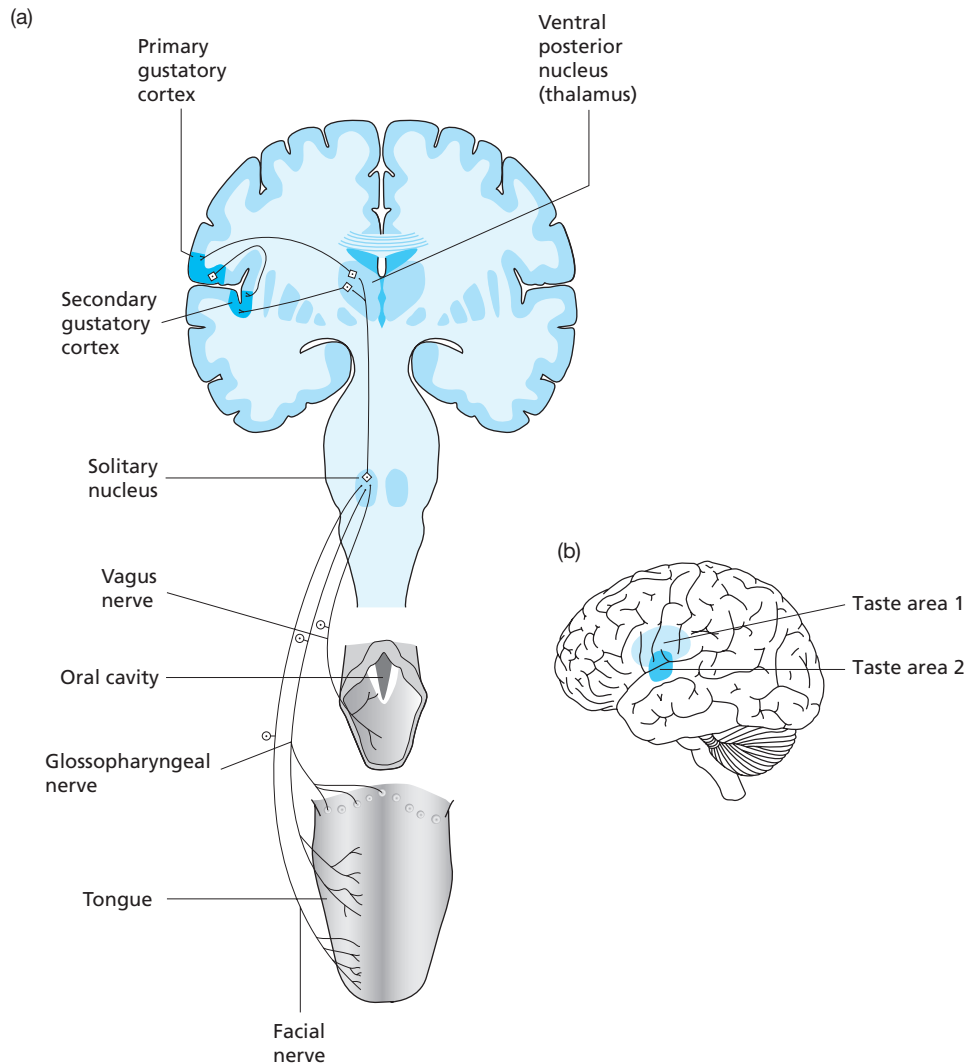

of the parietal cortex; the location of the secondary taste cortex is not as well documented but may be in the orbito-frontal cortex, where flavour is thought to be processed.

Other brain structures, such as the amygdala, contain cells that are responsive to taste, and these cells may be responsible for determining the hedonic quality of taste – whether the food is palatable. The amygdala forms part of an area that Small *et al.* (1997a) describe as the antero-medial temporal lobe (AMTL). In patients who have had this removed or damaged, there has been a reported increased sensitivity to bitter tastes and elevated ability to recognize, but not detect, citric acid. Small *et al.* (2001a) propose that this region plays an important role in perceiving the intensity of tastes, especially aversive taste. Patients with right AMTL lesions rate a bitter taste as significantly more intense than do healthy partici-

pants. One reason for the increase in intensity may be that the damage to the AMTL disinhibited cells in the cortex that are sensitive to taste concentration or palatability.

Olfactory system

Like the gustatory system, the olfactory system is important, if not more important, for the perception of food flavour. Unlike the sense of taste, the number of classes of stimulus that the olfactory system can perceive is apparently limitless. We can perceive thousands of different odours, but only very few tastes. This is why when individuals have a cold or the 'flu they fail to identify the foods they eat, claiming that the food has lost its taste. What they actually mean is that they cannot perceive the food's smell.

Initial perception in the olfactory system occurs at the back of the nasal cavities in a region called the olfactory neuroepithelium. This contains specialized receptors and three types of cell: olfactory sensory neurons, supporting cells and basal cells. Unlike the neurons in other parts of the central nervous system, the cells of the olfactory system are the only ones that can regenerate. The olfactory neuron extends a dendrite whose cilia extend into a layer of mucus; an axon from each receptor is sent to a structure called the olfactory bulb. There are two of these located beneath the frontal lobes in humans and non-human primates (Buck *et al.* 1994). The olfactory bulbs are made up of six layers of different types of neuron. One layer is the superficial olfactory nerve layer, which terminates in regions called glomeruli. The projection pathway of the olfactory bulbs is ipsilateral and fairly extensive, reaching the primary olfactory cortex (principally the piriform cortex), parts of the amygdaloid nucleus and the lateral part of the entorhinal cortex. All of these regions have reciprocal connections with the olfactory bulb (Kratskin 1995; see Figure 3.26).

Figure 3.26

The olfactory system (from Carlson, Neil, R. *Foundations of Physiological Psychology*, 3rd edition. Published by Allyn and Bacon, Boston, MA. Copyright © 1995 by Pearson Education. Reprinted by permission of the publisher)

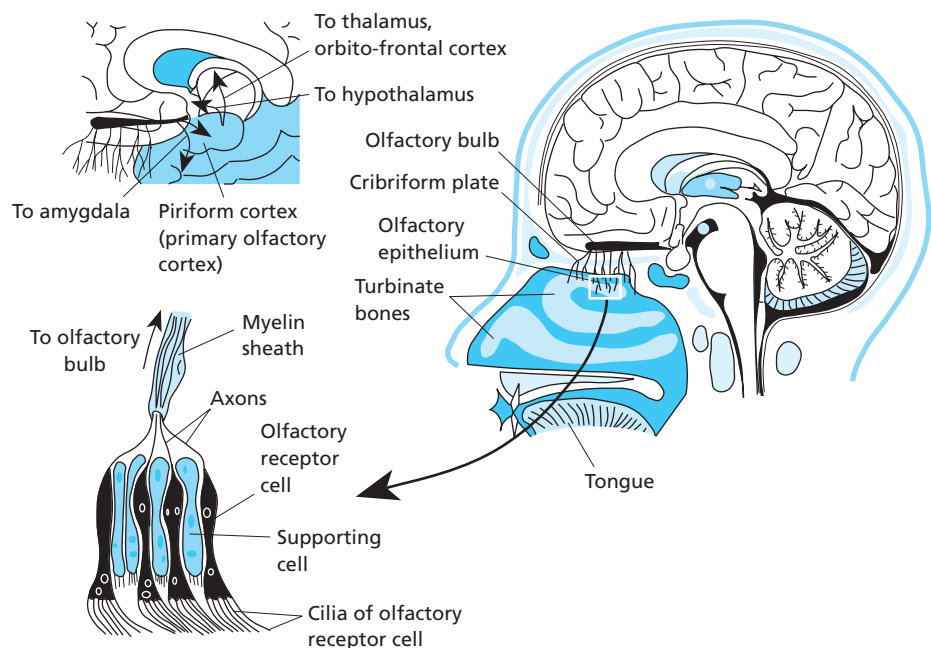

Some research has suggested that women are, on average, better at identifying, recognizing and detecting odours than are men (Doty *et al.* 1985). This sex difference may have important implications for any study of the neural basis of olfactory perception. If individual differences exist at the behavioural level (detecting, recognizing, identifying), then the brains of men and women may respond differently when they both smell the same odours. When men and women smelled pleasant, neutral and unpleasant odours (eugenol, ethyl alcohol and hydrogen sulphide), activation was greater in women, especially in the frontal and perisylvian regions (Yousem *et al.* 1999). Activation was greater in both left and right frontal hemispheres in women. Anderson *et al.* (2003) have further observed that whereas the amygdala responded to odours as they increased in intensity, the orbito-frontal cortex was activated when participants made judgements about the odours' pleasantness.

Motor system

The motor system is represented by those cells in the CNS that control the skeletal muscles. The general motor system is subserved by two distinct motor systems, one involving the peripheral motor neurons and another involving central motor neurons. Both of these systems are responsible for mediating the responses from muscles to motor centres, such as initiating movement. Other important structures play a part in these systems, such as the basal ganglia and the cerebellum, which are involved in execution and maintenance of motor behaviour rather than its initiation. The types of behaviour governed by the motor system can be crudely described as automatic and voluntary. Basic reflexive motor movements, such as withdrawing your hand from fire, are automatic, relying on spinal cord response. Precision grips are voluntary and require control at the cortical level. However, walking is neither fully one nor the other, being controlled by the brainstem or the cortex's control of the brainstem.

Peripheral motor system

Peripheral motor neurons send axons to skeletal muscles. Lower motor neurons are found in the ventral horn of the spinal cord and are of two types: alpha and gamma motor neurons. The axons of these neurons leave the spinal cord and innervate muscle at the trunk and extremities. When axons are damaged, muscle paralysis can result. As we saw in the section on cranial nerves, several of these nerves also innervate various muscles in the body.

Central motor system

The central motor system contains upper motor neurons important for voluntary movement and are found in the brainstem and cortex. The system is roughly divided into neurons of the pyramidal tract (also called the corticospinal tract) and the rest (the extrapyramidal system). The pyramidal tract is important for the execution of precise voluntary movement. Most fibres cross over to the opposite side of the body at the point of the medulla; the pyramidal tract is the only pathway making its way directly from the cortex to the spinal cord. Most motor neurons in this system are found in the fifth cortical layer, which contains pyramidal cells, but many, and the thickest, are found in the precentral gyrus (the primary motor area or MI). Electrically stimulating MI, as we saw in Chapter 1, produces muscle contraction.

Other motor tracts

Other tracts also pass impulses from higher cortical areas to the motor neurons in the spinal cord, as seen in Figure 3.27.

Figure 3.27

Motor tract pathways (from Carlson, Neil, R. *Foundations of Physiological Psychology*, 3rd edition. Published by Allyn and Bacon, Boston, MA. Copyright © 1995 by Pearson Education. Reprinted by permission of the publisher)

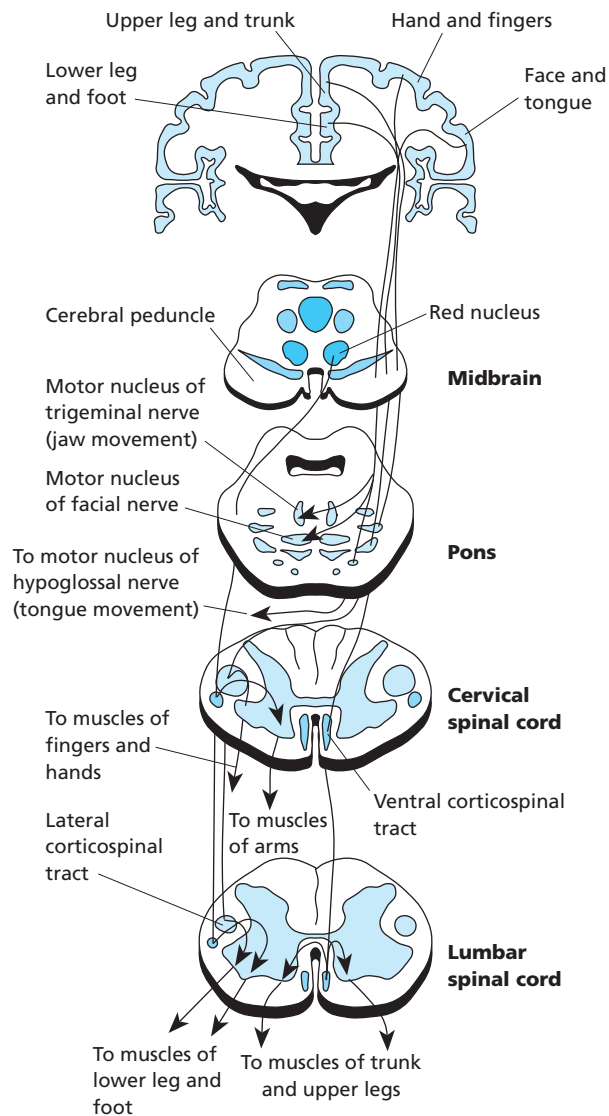

The cortex and movement

The higher brain areas responsible for the maintenance of voluntary movement are the primary motor cortex (PMC, also known as MI), the premotor area (A6) and the supplementary motor area (SMA), seen in Figure 3.28. The PMC is the more likely of the three to respond when electrically stimulated, and lesions to this area cause paralysis (damage to any part of the motor system, from motor cortex to motor neuron, can cause paralysis or partial paralysis). Areas 5 and 7 and the prefrontal cortex are also important cortical areas for movement.

The PMC receives afferent axons from a variety of areas, including areas 1, 2, 3, 5 and 6 and the ventro-lateral nucleus of the thalamus. As we saw in Chapter 1, a large part of

Figure 3.28

Cortical motor areas (from Kandel, E.R. *et al.*, *Essentials of Neural Science and Behaviour*, © 1995, McGraw-Hill/Appleton & Large, reproduced with permission of The McGraw-Hill Companies)

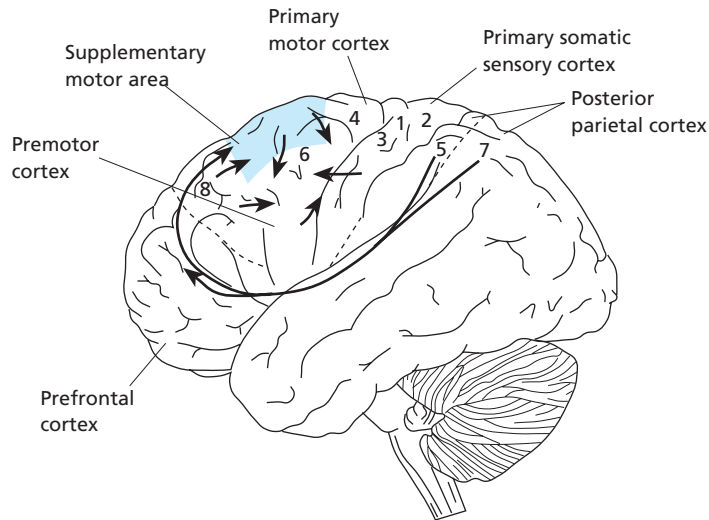

the PMC is devoted to hand movement (especially the finger and thumb), probably owing to the cortical requirements necessary to make precision movements. Stimulation of the PMC elicits movement in other muscles as well, such as the abdominal and back muscles. Unilateral or bilateral stimulation results in movement of these muscles. However, unilateral stimulation of the ‘hand area’ of the cortex produces movement in the contralateral hand, because pyramidal tract fibres are crossed.

The SMA appears to subserve a different type of motor behaviour. Whereas movement of the hand will activate the PMC, sequences of movement will activate the SMA. The ability to imagine also activates this part of the motor cortex, and it appears to be involved in motor planning and organization. Conversely, the premotor area is important for the control of visually guided movement such as coordinating hand movement when reaching for an object. The posterior parietal cortex also appears to play a role in movement in that its destruction will produce an inability to execute complex voluntary movements (apraxia). Apraxia and other movement disorders such as hemiparesis, Huntington’s chorea, Parkinsonism, Wilson’s disease, dyskinesia and upper and lower motor neuron disease are reviewed in Chapter 7.

Summary

The central nervous system begins as a hollow cylinder called a neural tube. This develops into the foundations of the CNS, neurons and glial cells. The brainstem comprises the medulla oblongata, the pons, the mesencephalon and the diencephalon. Most of the cranial nerves of the brain arise here. The mesencephalon contains the inferior and superior colliculi (two of each), which are involved in the relay of auditory and visual information, respectively. The diencephalon contains the thalamus and hypothalamus. The thalamus plays a vital role as a relay station for projections coming from various parts of the brain. The hypothalamus, lying anterior to and beneath the thalamus, is important for

a number of autonomic nervous system functions. The cerebellum extends from the pons and controls the execution of movement and maintenance of balance and posture. The cerebral cortex is the largest part of the CNS and is made up of six layers of convoluted and grooved neurons and axons. The grooves are called fissures or sulci. At the general level, the cortex is divided into four lobes: frontal, parietal, temporal and occipital. The temporal lobes are involved in audition, memory and (on the left) speech production; the occipital lobe is specialized for visual functions, the parietal lobe for spatial relations and somatosensation, and the frontal cortex with planning, strategy formation and (on the left) language production. There are many connections between brain regions: from the thalamus to the cortex and cortex to thalamus (thalamocortical connections) and from the cortex to other parts of the cortex (corticocortical connections). Many connections are made via association cortices. These regions do not receive direct motor or sensory inputs but do receive inputs from the primary sensory and motor cortices.

Recommended further reading

General neuroanatomy

Brodal, P. (1998). *The Central Nervous System: Structure and Function* (2nd edition). New York: Oxford University Press.

England, M.A. and Wakely, J. (1991). *A Colour Atlas of the Brain and Spinal Cord*. Aylesbury: Wolfe Publishing.

Nervous system development

Brown, M., Keynes, R. and Lumsden, A. (2001). *The Developing Brain*. Oxford: Oxford University Press.

The lobes of the brain and sensory/motor function

Cabeza, R. and Nyberg, L. (2000). Imaging cognition II: an empirical review of 275 PET and fMRI studies. *Journal of Cognitive Neuroscience*, 12, 1, 1–47.

Culham, J.C. and Kanwisher, N.G. (2001). Neuroimaging of cognitive functions in human parietal cortex. *Current Opinion in Neurobiology*, 11, 157–63.

De Valois, K.K. (2000). *Seeing*. Oxford: Oxford University Press.

Duncan, J. and Owen, A.M. (2000). Common regions of the human frontal lobe recruited by diverse cognitive demands. *Trends in Neurosciences*, 23, 10, 475–83.

Farah, M.J. (2001). *The Cognitive Neuroscience of Vision*. Oxford: Oxford University Press.

Funahashi, S. (2001). Neuronal mechanisms of executive control by the prefrontal cortex. *Neuroscience Research*, 39, 147–65.

Geary, D.C. and Huffman, K.J. (2002). Brain and cognitive evolution: forms of modularity and functions of mind. *Psychological Bulletin*, 128, 5, 667–98.

Griffiths, T.D., Warren, J.D., Scott, S.K., Nelken, I. and King, A.J. (2004). Critical processing of complex sound: a way forward? *Trends in Neurosciences*, 27, 4, 180–5.

Grill-Spector, K. and Malach, R. (2004). The human visual cortex. *Annual Review of Neuroscience*, 27, 649–768.

Jeannerod, M. (1997). *The Cognitive Neuroscience of Action*. Oxford: Basil Blackwell.

Logothetis, N.K. (1999). Vision: a window on consciousness. *Scientific American*, November, 44–51.

Martin, G.N. (2004). A neuroanatomy of flavour. *Petits Propos Culinaires*, 76, 58–79.

- Milner, A.D. (1998). Streams of consciousness: visual awareness and the brain. *Trends in Cognitive Sciences*, 2, 1, 25–30.
- Moller, A.R. (2000). *Hearing*. Oxford: Academic Press.
- Moller, A.R. (2002). *Sensory Systems*. Oxford: Academic Press.
- Rees, G. (2001). Neuroimaging of visual awareness in patients and normal subjects. *Current Opinion in Neurobiology*, 11, 150–6.
- Swinnen, S.P. and Wenderoth, N. (2004). Two hands, one brain: cognitive neuroscience of bimanual skill. *Trends in Cognitive Sciences*, 8, 1, 18–25.
- Zatorre, R.J., Belin, P. and Penhune, V.B. (2002). Structure and function of auditory cortex: music and speech. *Trends in Cognitive Sciences*, 6, 1, 37–46.
- Zeki, S. (2001). Localization and globalization in conscious vision. *Annual Review of Neuroscience*, 24, 57–86.

4

Hemispheric localization and lateralization of function

- Introduction
- Laterality in non-humans
- Laterality in humans
 - Physical asymmetry
 - Neuroanatomical asymmetry
- Functional hemispheric asymmetry: some preliminary observations
- Language
- Visuospatial ability
- Imagery
- Attention
- Perception of music
- Mathematical ability
- Individual differences
 - Sex and spatial ability
 - Sex and language
 - Handedness
 - Handedness, language and neuroimaging
 - The right-shift theory
- Interhemispheric communication: callosal syndromes
 - What is a callosal syndrome?
- Commissurotomy: A brief history
- Corpus callosum
- Characteristics of split-brain patients
 - Somatosensory effects
 - Visual effects
 - Other symptoms
- Compensatory actions
- Interhemispheric transfer: callosal channels?
- Models of interhemispheric transfer
 - Levy and Trevarthen's metacontrol
 - Banich's model of interhemispheric processing
 - Cook's model of corpus callosum function
- Why does hemispheric lateralization exist?
 - Motor theory of language development
 - Crowding
 - Global versus local processing
 - Geschwind and Galaburda's model
 - Stimulus – or processing – dependence?
- Summary
- Recommended further reading

Introduction

It [the brain] presents a paradox; it is a completely connected nerve net, and yet it is highly differentiated in its parts. How can these two characterizations be reconciled?

KINSBOURNE 1998

The brain has millions of connections between its regions and structures, allowing many neurons and groups of neurons to communicate with other groups of neurons. It is also characterized by neuronal specificity, i.e. the cells of each layer of the cortex tend to be different in cytoarchitecture. The brain also exhibits examples of functional specificity. There is a particular brain system for visual sensation and perception, for auditory sensation and perception, and so on. The system is modular: it is made up of semi-independent, self-contained 'modules' that perform discrete functions (Fodor 1983), although the history of neuropsychology, especially during its phrenological and functionalist period, indicates that the idea is not that recent. It would be unlikely and unwise for the apparatus that allows us to see to be the same as that which allows us to hear, touch, move, smell or taste. They are entirely different functions, often subserved by different and specific types of neuron, but are interconnected. Each sends and receives input to the other in a vastly complicated arrangement.

As you saw in Chapters 2 and 3, basic functions such as sensation, perception and movement has each got its own brain system. Components of these systems can be localized in fairly specific areas, hence the use of the terms 'auditory cortex', 'visual cortex', and so on. These sensory systems highlight localization of function at the basic sensory or motor level. However, localizing complex behaviour such as language, reasoning, visuospatial ability and emotion presents a greater challenge.

To begin with, associations between function and structure or regions of activation are often vaguely defined. For example, it is not helpful or particularly accurate to state that one part of the brain is responsible for language, because language is a complicated process or behaviour that involves a number of components. It has written, aural and spoken forms. It involves phonology and morphology. It may involve production and comprehension. In the same way that one part of our music system cannot fulfil all our musical wishes, 'one part' of the brain is unlikely to be responsible for all aspects of language. However, what is possible is to state that some areas may be responsible for specific elements of language, and this can be demonstrated experimentally. A similar problem besets concepts such as 'spatial ability', which can refer to many different functions: the mental rotation of letters or cubes, deciding which of several alternative shapes or patterns fits a space in a pattern, measuring distance, and map reading. As with language, however, it is possible to state that different regions may be responsible for different elements of visuospatial ability.

The above emphasis on language and spatial ability reflects the localization literature's preoccupation with the functions that neuropsychologists have sought to localize. Furthermore, these two functions, perhaps more than others, may be especially important because they are lateralized, i.e. one hemisphere is dominant for these functions. In Chapter 1, this phenomenon was referred to as asymmetry of function, hemispheric asymmetry and laterality. It is also referred to as hemispheric specialization. To all intents and purposes, all of these terms describe the same phenomenon.

Laterality in non-humans

Laterality refers to the preferential use or superior function of one part of the body and was first observed in humans. It was thought to reflect the human central nervous system's development from a simple, symmetrical system into a complex, finely tuned, specialized one (Corballis 1991). Laterality brought with it a greater flexibility and complexity of function: if some functions could be performed better by one aspect of the side of the body (including the brain), this would free the other side for other tasks; there would be no unnecessary duplication. One important behavioural example of laterality is handedness: the majority of humans express a preference for using the right hand (Gilbert and Wysocki 1992). The right hand also appears to be the 'manipulator' of objects, whereas the left is characterized as the 'holder' (in fact, the word 'dextrous', meaning right-handed, is synonymous with skilfulness). Our degree of laterality may be the functional characteristic that makes us unique and separates us, intellectually, from other mammals and higher primates (Corballis 1991).

However, there is evidence of lateralization of function even in species such as songbirds, domestic chickens, rats, cats, toads and non-human primates (Hiscock and Kinsbourne 1995). Songbirds, for example, have left-hemisphere control of song, although parrots appear to have symmetrical control of vocalization. Memory, learning and imprinting have been found to be severely impaired in chicks with lesions of the left intermediate medial hyperstriatum ventrale (Rose 1992). There appears to be a foot, claw, paw or hand preference in some species, although data are inconsistent and are based on various measures of handedness. Domestic chickens appear to prefer to use their right foot when scratching the ground; some cats preferentially use one paw over another when reaching for food (Warren *et al.* 1967), and similar right-pawedness has been found in toads (Bisazza *et al.* 1996). However, consistent asymmetries at the general population level are difficult to demonstrate.

Some non-human primates do not appear to show a preference in handedness at the general population level either, but they do show individual examples of hand preference. There are problems with the types of task administered to primates, however, in that not even humans would be expected to show strong laterality effects on them (Hiscock and Kinsbourne 1995). Tasks that elicit reliable human asymmetries do elicit some degree of primate laterality. For example, in Old World monkeys, the left hand appears to be the preferred limb for reaching and the right for manipulating objects (Hatta and Koike 1991). Fine motor skill, on the other hand, appears to involve preferential right-hand use (Morris *et al.* 1993).

Laterality in humans

Superficially, we appear to be physically symmetrical. We have two arms, legs, eyes, ears, nostrils, hands, thumbs and nipples. This symmetry is reflected in internal anatomy: we have two lungs and two kidneys, for example. Women have two ovaries; men have two testicles. We have two cerebral hemispheres. Yet this appearance belies some subtle, genuine physical and neuroanatomical asymmetries.

Physical asymmetry

One example of physical asymmetry is the face. A glance at Figure 4.1 quickly illustrates that the left and right sides of the face are not mirror images of each other. In fact, they are quite different. Furthermore, there is some evidence that the face is asymmetrically expressive, with a more intense expression found on the left side (Levy *et al.* 1983). Studies in which individuals have rated the attractiveness of both sides of a woman's face have shown that the right side is significantly more attractive than the left (Zaidel *et al.* 1995), although the evidence for the idea that asymmetrical faces are less attractive than symmetrical ones is mixed. Recent evidence suggests that a symmetrical face is associated with greater health (Zaidel *et al.* 2005), but this notion is even more controversial.

Figure 4.1

Asymmetry of the face revealed by constructing composite faces in which the face is made up of the same two sides (from Martin Skinner)



Neuroanatomical asymmetry

The brain itself, although appearing outwardly symmetrical, exhibits elements of asymmetry. These asymmetries are summarized in Table 4.1.

One of the earliest reports of cerebral asymmetry described two transverse gyri on the right and one on the left in the majority of *post mortem* human brains (Heschl 1878). The left gyrus was subsequently found to be more oblique than the right (Galaburda 1995) and doubled over more on the right (Campain and Minckler 1976; Chi *et al.* 1977), although these findings have been contradicted in a smaller set of brains (Rademacher *et al.* 1993). These gyri, known as Heschl's gyri, represent the primary auditory cortex.

There are several other examples of asymmetry at the neuroanatomical level. The right hemisphere, for example, is thought to be larger and heavier than the left (Heschl 1878; Schwartz *et al.* 1985), although this observation has been challenged (Hadziselimovic and Cus 1966). The left occipital lobe was found to be larger than the right in a study by Cunningham (1892), whereas a larger right than left frontal lobe has been reported (Weinberger *et al.* 1982).

Pfeifer (1936) reported a larger planum temporale, a structure in the Sylvian fissure posterior to the primary auditory cortex, in the left hemisphere than in the right. Pfeifer's finding was subsequently replicated in 65 percent of the 100 cases studied by Geschwind and Levitsky (1968) and in 82 percent of the 100 brains studied by Wada *et al.* (1975). In Geschwind and Levitsky's sample, 11 percent had a larger right planum temporale, whereas 24 percent had symmetrical plana. These results are also reflected in human foetal brain data: these brains show left-sided planum temporale asymmetry (Teszner *et al.* 1972; Witelson and Pallie 1973).

Table 4.1 Summary of neuroanatomical asymmetries in the human brain

Structure/region	Characteristics	Reference
Heschl's gyri	Two in RH; one in LH	Heschl (1878)
	More oblique in LH	Galaburda (1995)
Right hemisphere	Larger/heavier than LH	Heschl (1878); Schwartz <i>et al.</i> (1985)
Left occipital lobe	Larger than right	Cunningham (1892)
Right frontal lobe	Larger than left	Weinberger <i>et al.</i> (1982)
Planum temporale	Larger in LH	Pfeifer (1936); Geschwind and Levitsky (1968); Wada <i>et al.</i> (1975)
Tpt	Larger in LH	Galaburda <i>et al.</i> (1978)
Sylvian fissure	Larger in LH	Eberstaller (1890); Cunningham (1892); Yeni-Komishian and Benson (1976)
Pallidum	Larger in LH	Kooistra and Heilman (1988)
Area 44	Larger in LH	Eberstaller (1890); Galaburda (1980)

RH = right hemisphere; LH = left hemisphere

The planum corresponds to area 22 and has a specific cytoarchitectonic organization called Tpt, which appears to contain features of the auditory association cortex and parietal higher-order association cortex. In other words, the area is functionally the same as Wernicke's area, the region responsible for the comprehension of language. Not surprisingly, Tpt has been found to be up to seven times larger in the left than the right hemisphere (Galaburda *et al.* 1978).

The human brain also has a longer Sylvian (lateral) fissure in the left hemisphere (Yeni-Komishian and Benson 1976), a finding that dates back to Eberstaller (1890) and Cunningham (1892), who, in addition, observed that the left fissure was more nearly horizontal than the right.

The importance of neuroanatomical asymmetries lies in their possible relationship with function. If the planum temporale is larger on the left, specifically in that part of the left hemisphere that we know governs aspects of speech, is this physical asymmetry related to functional asymmetry? However, demonstrating conclusive relationships of this kind may be impossible: the relationship between anatomical asymmetry and functional significance is far from clear (Beaton 1997).

Galaburda (1995) highlights a number of problems associated with studies claiming to demonstrate neuroanatomical asymmetries. These problems include the variability in the description of structures such as the planum temporale, the use of inappropriate methods of localization (such as an MRI scan employing a horizontal plane that is too near to that of the planum temporale), and the fact that the cortex is folded and manifests gyri, fissures and sulci for a reason: to fit inside the skull. It is possible that cortical folding is the result of nothing more grand than the imposition of the skull on the cortex's shape so that asymmetries in folds could reflect functionally meaningless bony asymmetries.

Instead, Galaburda (1995) argues that one possible means of demonstrating clear asymmetries would be to look at neuroanatomy at the morphological level. Area Tpt, for example, has a distinct cytoarchitecture and is positively correlated with planum temporale asymmetry (it may even be responsible for the planum's asymmetry). Furthermore, instead of looking at relative size, perhaps attention should be directed towards the density of neurons in a given area. Galaburda has argued that the generation of asymmetry is attributable to the asymmetric production (and subsequent death) of neurons. Galaburda and others' work has involved mainly non-human data. An extensive exploration of data from other species would obviously be valuable.

Functional hemispheric asymmetry: some preliminary observations

The conventional view of hemispheric function is that the left hemisphere is rational, verbal, linear and analytic, whereas the right hemisphere is emotional, spatial, holistic and intuitive (Bradshaw and Nettleton 1981; Van Lancker 1997). The left and right hemispheres have even been characterized as representing 'Western' and 'Eastern' styles of thinking, respectively (Corballis 1991).

Underlying this dichotomy is the suggestion that the two hemispheres are qualitatively and quantitatively different. This idea was pursued in the early nineteenth century by the English physician Arthur Wigan in his book *The Duality of Mind*. Wigan (1844) had argued that the two hemispheres were independent entities that required efficient coordi-

nation in order to function adequately. This notion of the independence of the hemispheres was given a more vivid spin following reports of split-brain patients, who, because the fibres connecting their cerebral hemispheres had been severed to block the path of epileptic seizure, appeared to have 'two brains'. Information available to one hemisphere did not appear to be available to the other. The behaviour of split-brain patients is discussed more fully in the next chapter.

This dichotomy, although crude, is generally accurate. That is, the left hemisphere does appear to be a more effective processor of language; the right hemisphere does appear to be more involved in aspects of visuospatial ability. However, there are complications and ambiguities that cloud these apparently straightforward dichotomies. For example, the right hemisphere is capable of undertaking rudimentary or compensatory language processing, and the left hemisphere is capable of undertaking some spatial processing. Individual differences such as sex and handedness further complicate the pattern and development of functional hemispheric asymmetry, and these differences are dealt with in a separate section later in the chapter.

Language

Invasive and non-invasive studies have shown left hemisphere dominance for speech and various language processes. Various categories of language task have been studied: written word recognition/reading, spoken word recognition, written and spoken word comprehension and speech production. As Chapter 1 showed, the single-case studies of the nineteenth century were the first to provide some relatively systematic evidence that the left hemisphere was specialized for specific language functions such as speech production. These studies led to what has become known as the Wernicke–Broca–Lichtheim model of language: that auditory representation of words was localized in the posterior temporal regions and that motor representation of words was localized in the frontal region. However, this model was challenged by work published in the 1970s and 1980s. Famously, Caramazza and Zurif (1976) published research based on a group of Broca's aphasia patients, which found that although these patients had generally good comprehension, they showed poor comprehension when understanding depended on having an awareness of the syntactic information in a sentence. For example, they were unable to match a picture to the sentence 'the dog was chased by the cat' when the picture featured a cat chasing a dog. This ground-breaking study, and those that followed, challenged the notion that Broca's aphasia patients had preserved comprehension and presented an even greater challenge to the auditory/motor representational model that emerged from the nineteenth century. This debate is covered in more detail in Chapter 8, which includes challenges to the challenge itself, but it is important to note it here because it is often reported in convenient shorthand that damage to Broca's and Wernicke's areas has well-defined and stereotypical consequences (poor speech production and comprehension, respectively) when the picture is often much less clear, and much more messy, than that.

Specific challenges to models aside, however, regions of the left hemisphere have been found to be more actively recruited during word-processing tasks such as spoken word recognition and spoken word production. These findings have emerged from single-case studies and from neuroimaging studies of healthy individuals. Such studies have measured language ability and performance in very specific ways. For example, studies have investigated the representation of semantic knowledge and have found that the left middle and

inferior temporal lobe is implicated in patients and in healthy individuals (Dronkers *et al.* 1994; Mummery *et al.* 2000). Others have found dissociations between the production and understanding of word class, with some patients being unable to understand or read function words but able to read content words without a problem. Models of reading have been proposed based on such work, and these are considered in Chapter 8. The regions of the brain principally implicated in language processes can be seen in Figure 4.2.

In a pioneering PET study of single-word processing, Petersen and colleagues reported increased activation in the left posterior temporal cortex during passive listening to words (Petersen *et al.* 1988). When subjects had to decide whether pairs of spoken syllables ended in a consonant or not, an increase in blood flow to Broca's area was observed (Zatorre *et al.* 1992a). Similar left-sided increases have been found during word-association tasks, even in left-handers (Markus and Boland 1992).

Early studies have been supported by later investigations, which have examined more specific aspects of linguistic processing. Price and colleagues reported greater activity in the left inferior and middle frontal cortices during a lexical decision task, whereas increases in the left middle and superior temporal regions were found during reading aloud and silently (Price *et al.* 1994). Petersen and co-workers also reported left-sided activity during a word-recognition task (Petersen *et al.* 1990). Specifically, silent viewing of words and pseudo-words activated the left medial extrastriate cortex, but silent viewing of consonant strings did not. They argued that this brain region was associated with visual word recognition and not phonological processing.

Later studies extended research beyond single-word processing to the study of sentence and discourse comprehension. This can involve not simply the understanding of the literal meaning of a sentence – that it makes grammatical sense – but also the understanding of the thematic content of a sentence: does a sentence represent a joke or a view of morality or the cause of offence? The temporal poles and middle and superior frontal regions of the right hemisphere appear to be important here. These are activated during sentence comprehension – the right hemisphere also appears to be activated when a sentence or a story is coherent. In one study, right hemisphere activation was significantly greater when participants read a titled than an untitled story (St George *et al.* 1999).

The right hemisphere might also play a role in the appreciation of irony and metaphors. Bottini and colleagues reported that sentence comprehension was associated

Figure 4.2

The areas of the brain involved in language tasks, according to recent neuroimaging data (adapted from Cabeza and Nyberg 2000. © 2000 by the Massachusetts Institute of Technology)

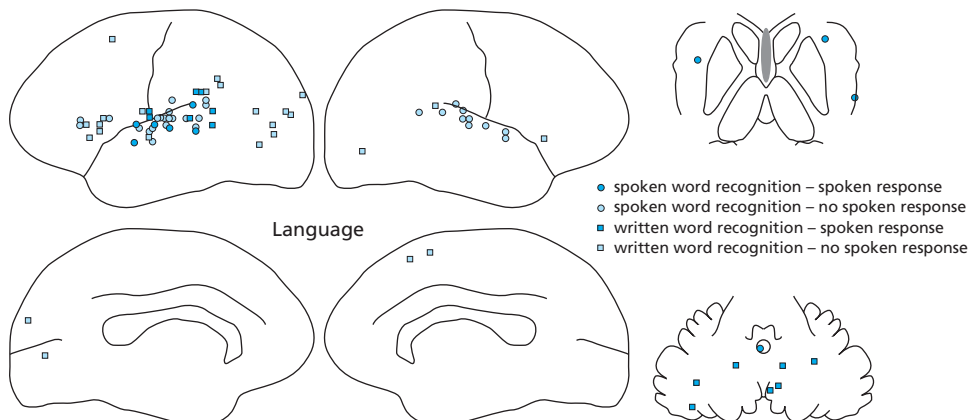

with the typical increased activation in left hemisphere regions such as the prefrontal and basal frontal cortex and the middle and inferior temporal gyri, but metaphor understanding activated various parts of the right hemisphere, including the right prefrontal cortex and the middle temporal gyrus (Bottini *et al.* 1994).

Visuospatial ability

Visuospatial ability appears to be more reliant on the performance of the right than the left hemisphere (De Renzi 1982), although not all visuospatial tasks tap the same visuospatial function. A division has been suggested between tests of mental rotation ability, which do appear to elicit reliable hemispheric asymmetries, and tests involving spatial relations, such as the organization of elements in a stimulus configuration (McGhee 1979). Kosslyn (1987) has also distinguished between spatial tasks that involve assigning spatial relations to a category such as ‘outside of’ or ‘above’ and those that involve making decisions about metric distances between spatial relations. The right hemisphere makes better use of the latter; the left hemisphere makes better use of the former.

One of the more common tasks of visuospatial ability involves spatial transformation such as mental rotation. There are several types of mental rotation task, but the most widely used is that of Shepard (Cooper and Shepard 1973; Shepard and Metzler 1971). This task involves imagining the rotation of a series of stimuli (cubes, letters, digits) so that their position and orientation match the position and orientation of another set of rotated or unrotated target stimuli (Figures 4.3 and 4.4).

Evidence from a number of sources suggests that mental rotation is largely a function of the right hemisphere, although this is not clear-cut (Corballis 1997a). Right posterior brain damage is associated with mental rotation deficit (Butters *et al.* 1970), whereas a left visual field advantage is found for mental rotation in healthy individuals (Ditunno and Mann 1990). While neuroimaging studies have suggested involvement of the back of the brain (the posterior parietal cortex) when rotating images ‘in the mind’, the roles of

Figure 4.3

A typical rotation task. Which of the four alternatives represents the cubes on top? (reprinted with permission from *Mental rotation of three-dimensional objects*, *Science*, 171, pp. 701–3, Figure 1, Shepard, R.N. and Metzler, D. © 1971 AAAS)

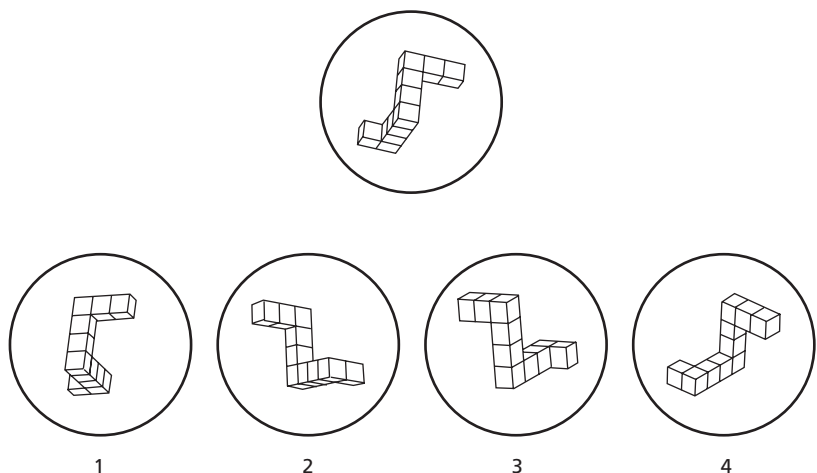
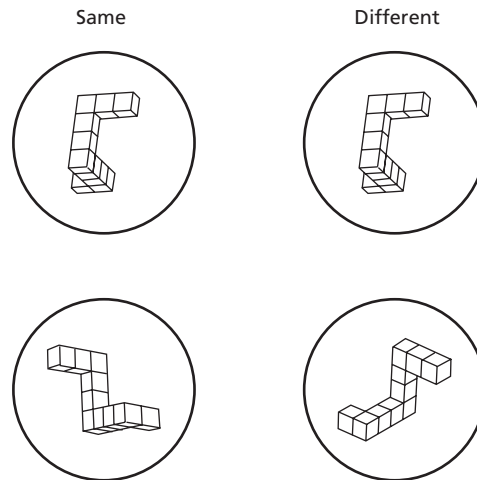

Figure 4.4

Another rotation task. The task is to decide whether each set of cubes is the same or different (reprinted with permission from Mental rotation of three-dimensional objects, *Science*, 171, pp. 701–3, Figure 1, Shepard, R.N. and Metzler, D. © 1971 AAAS)



the left and right parietal cortex in the task are unclear. Harris *et al.* (2000) examined participants' ability to decide whether alphanumeric stimuli at different degrees of orientation were mirror-reversed or not. As expected from this task, individuals took longer to make a decision the more the stimuli were rotated from their normal upright position. When brain activity was analysed, Harris *et al.* found only one area that was active during the task, and this was the right posterior parietal lobe. This parietal cortex, when damaged, results in various perceptual disorders (as described in Chapter 6). Harris *et al.* suggest that the right side, in particular, is responsible for the spatial transformations necessary for mental rotation.

In the event-related potential (ERP) literature, larger ERPs have been reported for the right than for the left hemisphere for the N2 and P3 components during mental rotation (Desrocher *et al.* 1995). Desrocher and colleagues have suggested that the processes involved in mental rotation can be broken up into separate operations, each of which follows a particular time course. Thus, stimulus evaluation occurs in the first 200–300 ms of the task, evaluation of the complexity of the stimuli and the selection of strategy occurs between 300 and 400 ms, actual rotation in the 400–800 ms window, and decision making in the 1000–1200 ms window. The frontal areas are thought to be associated with the first two stages (stimulus evaluation and strategy formation), with centroparietal regions thought to be involved in the final two stages (rotation and decision).

Other visuospatial right hemisphere functions include the perception and recognition of non-verbal visual stimuli such as faces. Visual field studies also show a right hemisphere advantage for face recognition, i.e. it recognizes facial expressions more quickly than does the left hemisphere (Rizolatti *et al.* 1971). This impairment in visuospatial function extends to other stimuli as well as to faces. Individuals with unilateral right hemisphere damage, for example, have greater difficulty than those with left-sided lesions in differentiating ground from figure (Russo and Vignolo 1967) and in localizing points in space (Hannay *et al.* 1976). Visual field studies in neurologically healthy individuals have confirmed the right hemisphere's 'superiority' in localizing dots (Kimura 1969).

Spatial processing is not limited exclusively to the right hemisphere, however. Mehta and Newcombe (1991), for example, have found that left hemisphere lesions were associated with impaired performance on a task in which individuals had to indicate which of ten lines, spaced at equal angles up to 180 degrees, were at the same angle as two lines presented in isolation. These subjects also showed deficits on two shape rotation tasks.

Vogel *et al.* (2003) meta-analysed data collected from spatial ability studies that used medical, psychological or other measures of lateralization. Medical measures included neuroimaging, psychological measures included response times, and other measurements included handedness and hand skill. In general, a right hemisphere advantage was found for spatial skill across all types of measure. However, the medical measures were those most reliably associated with this advantage; studies in which spatial ability was examined by looking at how well each hand performed at a task showed no right hemisphere advantage. There is a large body of neuroimaging data concerning spatial skill, and these are consistent in their findings.

More intriguingly, those people described as having high spatial ability showed no hemisphere preference, but people with poor ability were more likely to show right hemisphere advantage. The reviewers caution that this conclusion is based on very small sample sizes, however. Simple spatial visualization did not produce a right hemisphere advantage, but tests in which orientation or manipulation of images was expected did. Finally, men showed a greater right hemisphere advantage than women, who showed no hemisphere preference.

The review suggests that although spatial skill is typically associated with right hemisphere involvement, the relationship is more complex than this. It is affected by the type of spatial skill task used, the measure of brain activity, the sex of the participant and, possibly, the degree of skill that participants possess.

Imagery

One of the intriguing questions in cognitive and neuropsychology is whether the events we mentally imagine recruit the same brain regions as those recruited in the perception of those events (Kaski 2002). For example, does visual imagery use the same brain areas as those involved in visual perception? Additionally, does the imagining of different types of 'mental' content activate different brain areas, and if so, are they areas that would be normally activated by the actual perception of such content (so that imagining faces activates the same area as that activated by the viewing of actual faces)? There is some evidence that they are.

The mental manipulation of objects – such as rotating objects in the mind in order to reach a target position – is associated with activity in the temporal and parietal cortices (Kosslyn *et al.* 1998). Other studies show considerable overlap between imagination and actual perception of objects. The brain areas activated by mentally imagining faces are different to those activated by imagining places (O'Craven and Kanwisher 2000). The fusiform face area is also significantly more active during the mental imagining of faces than places. Imagining places activates the parahippocampal place area (PPA) to a much greater extent than did the faces.

In another experiment, the brain activation generated by the visual imagery of places and faces and the actual viewing of places and faces was compared (O'Craven and Kanwisher 2000). Similar stimulus-specific regions were activated by imagery and viewing, but the activation was much stronger for the viewing of the images.

Figure 4.5

The areas of the brain involved in imagery tasks, according to recent neuroimaging data (adapted from Cabeza and Nyberg 2000. © 2000 by the Massachusetts Institute of Technology)

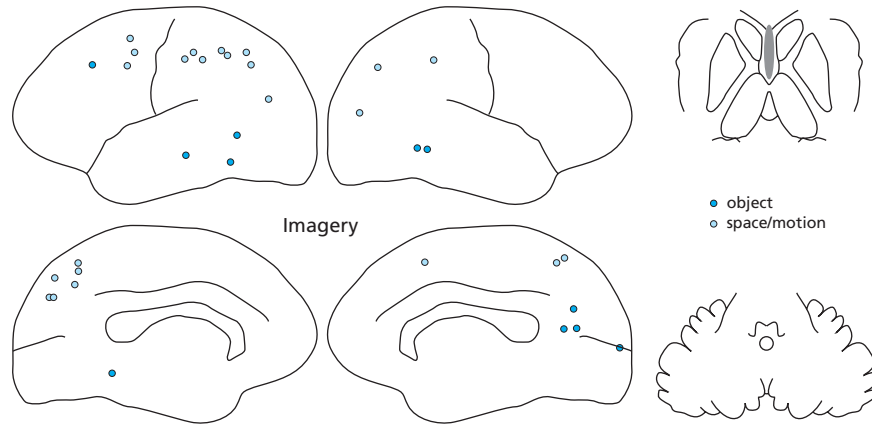

The results are similar to those found by Goebel *et al.* (1998), who reported that the brain region activated during visual motion was also activated by mental imagery of that motion. There is also a great similarity between the areas that respond during the act of writing and those during the mental imagery of the writing (Sugishita *et al.* 1996).

Evidence at the cellular level also suggests an overlap between neurons that respond to perception and the imagination of perception (Kreiman *et al.* 2000a). Kreiman *et al.* found that 88 percent of the neurons whose activity they recorded from the hippocampus, amygdala and parahippocampal gyrus were active during the visual perception of objects such as faces showing emotion, household objects, spatial layouts, animals, drawings, and photographs of famous people, foods and complex patterns, as well as during the mental imagery of these objects. Some neurons responded during imagery but not during visual perception, and *vice versa*. These findings suggest some degree of neuronal generality during two similar behaviours that differ only in terms of execution: the neurons firing during perception may also undertake the task of visually imagining the 'perceived' object. Figure 4.5 shows those areas of the brain that are activated during visual imagery.

These studies suggest that the mechanisms responsible for visual perception of images and those responsible for the mental imagining of the same images may be similar. Similar shared activation is also seen in other sensory modalities, such as olfaction, where the left and right rostral insula were activated during the imagination and perception of rose, pine needle, lemon and strawberry odours (Djordjevic *et al.* 2004), as Plate 4.1 shows. The mechanism of visual perception and imagery may be shared. The results from O'Craven and Kanwisher's study, for example, suggest that the difference in activation between the two types of condition (imagery versus viewing) is one of degree.

Attention

Attention is the process that allows us to direct our cognition towards a particular event, object or place. Psychologists refer to different types, including sustained attention, selective attention and divided attention. Sustained attention refers to our ability to pay

attention to a stimulus over a long period of time. The monitoring of computer screens for information (as is done in air traffic control), is one example.

The process that controls our awareness of particular categories of events in the environment is called selective attention. This process determines which events we become conscious of; we can orient our responses depending on whether attention is controlled automatically, as it would be if we hear a loud bang and turn towards the likely source, or whether attention is guided by instruction, as it would be if we were asked to look out for a red Porsche entering a carpark, or whether attention is manipulated by task demands, as it is when we follow the instructions on road signs as a driver or pedestrian. The mechanism that allows such attention means that we can respond to some stimuli while excluding others (hence 'selective attention').

Divided attention refers to the process whereby attention is split between our execution of two or more tasks. Our finite attentional resources are normally allocated to the most important task. In experiments where individuals have to undertake two tasks simultaneously (this is called dual-task methodology), performance on both tasks diminishes, but experiments in which typists were asked to transcribe text and complete a shadowing task at the same time found the participants were able to do this effectively (Shaffer 1975). Sometimes, two tasks can be performed as well as one can. To explain this, multiple-resource models of attention argue that there are several resource pools that deal with various cognitive and perceptual processes. When two tasks compete for the same resource, this will result in an impairment in task performance, but when tasks compete for different resource pools, then both should be performed successfully. However, a problem with the resource model is operationally defining a resource and the types of task that would use the different 'resources'. There is no general agreement on what the different types of resource are.

The left and right cerebral hemispheres appear to play different roles in attention. Focal attention (which involves attention to local cues) depends on the left hemisphere, whereas global attention (a holistic approach that takes in whole objects or scenes) is dependent on the right hemisphere (Fink *et al.* 1996). This asymmetry of function may explain the symptoms seen in the perceptual disorder spatial neglect, described in Chapter 6, in which brain-injured (usually right-hemisphere-damaged) patients are unable to report or respond to stimuli contralateral to the side of the brain injury.

Sustained attention has been associated with increased activation in the right prefrontal and parietal cortices, based on PET and fMRI findings, but generally there is a network of regions traversing the right fronto-parietal regions that are involved in sustained attention (Coull *et al.* 1996), as Figure 4.6 shows.

Selective attention has been associated with increases in activation in posterior regions, but the region of activation depends on the type of attention that is selectively applied. If one sensory modality is attended to, regions associated with other modalities show suppressed activation (Haxby *et al.* 1994; Ghatan *et al.* 1998). Attending to a stimulus's movement has been associated with activation in the occipito-temporal region (Beauchamp *et al.* 1997), with the prefrontal cortex and the cerebellum possibly modulating attention (Rees *et al.* 1997). Divided attention also recruits the prefrontal cortex, especially the left (Benedict *et al.* 1998; Vandenberghe *et al.* 1997). Posner and Petersen (1990) have characterized the ability to shift attention in three ways: the first component of attention allows the disengagement of attention from its current location (a function of the posterior parietal cortex); the second guides attention from the current location to the new location (a function of the superior colliculus, frontal eye fields and related structures); and the third component allows the re-engagement of attention to the new location (a function of the thalamus).

Figure 4.6

The areas of the brain involved in attention, according to recent neuroimaging data (adapted from Cabeza and Nyberg 2000. © 2000 by the Massachusetts Institute of Technology)

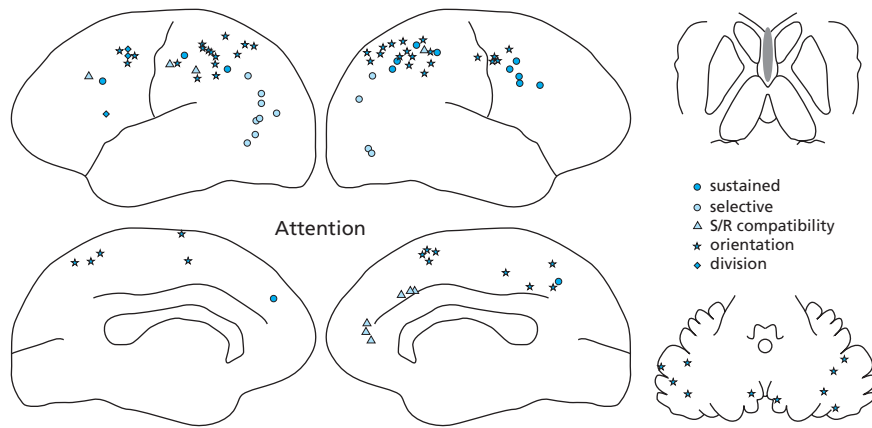

Attention reflects the state of neurons at a given time in a given context. Luck *et al.* (1993) recorded the activity of single neurons in the visual association cortex of monkeys as they were cued to pay attention to the location of stimuli. When a cue indicated that the monkey should watch for a stimulus in a particular location, neurons that received input from the appropriate part of the visual field began firing more rapidly. These neurons seemed to be ‘primed’ for detecting a stimulus in their part of the visual field.

Perception of music

Although the right ear appears to be superior at identifying verbal material, there is evidence to suggest that musical chords and melodies are processed better when presented to the left ear (Kimura 1964; Bartholomeus 1974; Gordon 1980). This has also been reported for harmonies, pitch and timbre.

Trained musicians appear to show left hemisphere superiority in the recognition of melodies, whereas untrained subjects show a right hemisphere advantage (Bever and Chiarello 1974). Similarly, Davidson and Schwartz (1977) found that musicians showed more left hemisphere EEG activation when they whistled than did non-musicians. Both musicians and non-musicians showed left hemisphere activation during the recitation of song lyrics. This evidence lends support to the notion that musicians are inclined to use their more ‘analytic’ hemisphere (the left) than are non-musicians, who performed no such analysis or did not have the ability to do so.

In another study, a larger planum temporale was found in those musicians with perfect pitch than in non-musicians or musicians without perfect pitch (Schlaug *et al.* 1995), suggesting the further involvement of the left hemisphere in certain music-related abilities. This suggestion is supported by a PET study in which left hemisphere activation was greater during tasks involving musical familiarity, pitch and timbre in six musically naive subjects. Further specific activations were found for each task, possibly reflecting the different mental strategies involved in each task (Platel *et al.* 1997).

A recent study examined how brain activation would change following a period of training in musical competence. Stewart *et al.* (2003) used fMRI to measure activation in two groups of volunteers: those with no musical training but who were given fifteen weeks of musical training on a keyboard and a similar group who did not receive training. Scanning occurred prior to the training period and after the training period was over, and all participants were required to read sheet music and indicate whether a visual stimulus could form a musical symbol. The learners, during sight-reading of music, activated the superior parietal cortex bilaterally. This effect was not found in the non-learners. The significance of this region, according to the authors, lies in the proposition that it contains the 'dorsal visual processing stream' (there is more on this in Chapter 8), which is important for coding spatial aspects of visual stimuli. Perhaps the parietal activation observed might reflect the translation of visuospatial stimuli (notes) into meaningful units (sounds).

The implicit task was associated with increased activation in some frontal regions, including the left supramarginal gyrus, an area that the authors consider to be important for 'motor intention' so that 'the visual appearance of musical notes, post-training, may be automatically and unconsciously interpreted as an instruction to act'.

Singing, like any vocal behaviour, utilizes parts of the brain. Perry *et al.* (1999) measured cerebral blood flow as participants sang a single pitch or a single vowel and then compared these conditions with those in which the participants listened to complex tones. Predictably, the vocal condition activated the supplementary motor area and cerebellum, as well as other motor-related regions. The pattern of activation was similar to that observed during speech production. However, greater right-sided activation in the temporal cortex (the primary auditory cortex) was observed when singing than when passively listening. This may be the area responsible for the processing of complex pitches. Singing therefore seems to share many of the cortical activation features of speech but with some opposite functional asymmetries that are singing-relevant.

Mathematical ability

Difficulties in performing mathematical operations fall into various categories. Individuals may exhibit difficulties in reading numbers (alexia) or writing them (agraphia). The terms 'alexia' and 'agraphia' have a more general currency in neuropsychology (the former means reading difficulty, the latter difficulty in writing). Therefore, strictly speaking, the disorders encountered in mathematics should be termed alexia and agraphia for numbers. Other mathematical difficulties include problems in representing numerical information spatially by misreading signs, omitting numbers or having problems with decimal places despite preserved number reading and writing skills (spatial acalulia), and in retrieving arithmetical information from long-term memory despite preserved number reading and writing and spatial representation of numbers (anarithmetria).

Alexia and agraphia for numbers usually occur in the absence of other arithmetical disabilities and are associated with left hemisphere lesions (Hecaen 1962). Spatial acalulia, on the other hand, is associated with posterior right hemisphere damage (Benson and Weir 1972; Spiers 1987), possibly because of the emphasis on visuospatial skills in calculation and arithmetical calculations. In support of this, Hartje (1987) has noted that counters and the manipulation of counters are widely used during children's learning of arithmetical skills. Anarithmetria appears to be a consequence of posterior left hemisphere damage (McCloskey *et al.* 1991), although there appears to be a dissociation

within this disability in that a failure in the retrieval of facts or an inability to carry out arithmetical procedures can be observed. However, the primary deficit seen in anarithmetria appears to be difficulty in arithmetical fact retrieval (Geary 1993). The evidence thus appears to confirm the predominant involvement of the right hemisphere in mathematical tasks, possibly because of the spatial nature of some of the tasks involved in mathematics.

Frontal and parietal cortices have been implicated in the performance of mental arithmetic. Menon *et al.* (2000) observed that the left and right angular gyri – parts of the cortex located in the parietal lobe – were selectively active during mental calculation and other researchers have found activation in the same area (Cowell *et al.* 2000). A recent neuroanatomical study has found that this region is smaller in children with mathematical operations deficits compared with children with normal maths performance (Isaacs *et al.* 2001).

Children of low birth weight are known to develop deficits in cognitive ability later in life. Isaacs *et al.* (*ibid.*) investigated whether there would be a neural correlate of mental arithmetic deficits in adolescent children who had been born at 30 weeks' gestation. The children were given mental arithmetic tests (addition, subtraction, multiplication and division; problem solving, statistics and understanding of graphs) basic reading, spelling and comprehension tests and the full version of the Wechsler Intelligence Scale for Children III (a test of IQ discussed in Chapter 14). One group of children had specific arithmetic deficits; another (control) group had scores within the normal range; a third group had deficient mathematical reasoning skills; a fourth group was able to reason mathematically.

While there was no significant difference in scores between groups for the reading and intelligence tests, there were differences on the mathematics tests. Those children with numerical operations problems performed more poorly than a control group on tests of numerical operations such as division and addition. When the researchers correlated the performance of the group with brain volume, they found that the low birth weight children with good numerical operations ability had greater grey matter in the left parietal lobe than did the low birth weight children. No such difference in regional mass was found between children with deficient mathematical reasoning ability and those with good ability, suggesting that this specific region may be involved in mediating aspects of mental calculation. The results are compatible with a reported single-case study of developmental dyscalculia (the development of mathematical impairment), which showed decreased activation in the left temporo-parietal cortex (Levy *et al.* 1999).

Individual differences

Sex and spatial ability

Sex exerts a significant influence over the degree and type of functional lateralization. Whereas there is some evidence to suggest that verbal ability is less lateralized in right-handed women than right-handed men (McGlone 1980; Hiscock *et al.* 1994), the most stereotypical sex difference emerges on tests of visuospatial ability (McKeever 1991; Van Strien and Bouma 1995). Examples of the types of test eliciting sex differences are seen in Figure 4.7. Kimura (2004) has summarized some of the more consistent differences in cognition between men and women: men, in general, are superior at certain spatial tasks (such as mental rotation), throwing accuracy and mathematical reasoning, whereas

Figure 4.7

Two visuospatial tasks on which sex differences are found. In (a), the task is to indicate whether the shape on the card is the same as the stimulus; in (b), the task is to indicate which glove the target glove represents (from Kimura 1999)

(a)

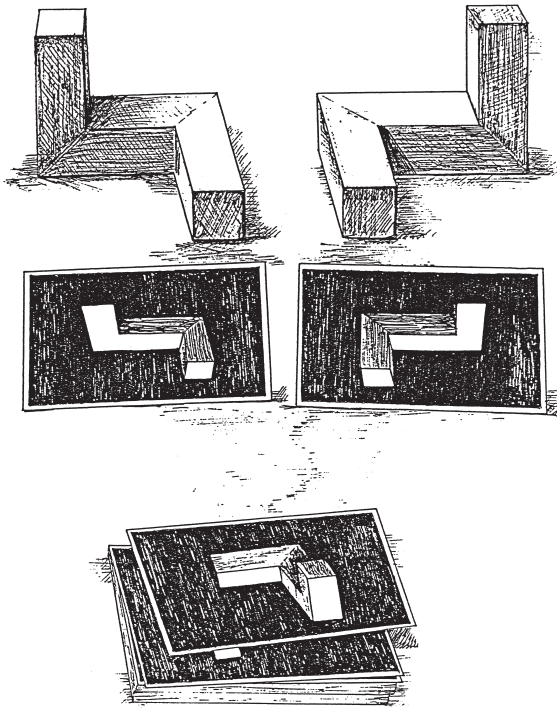

(b)

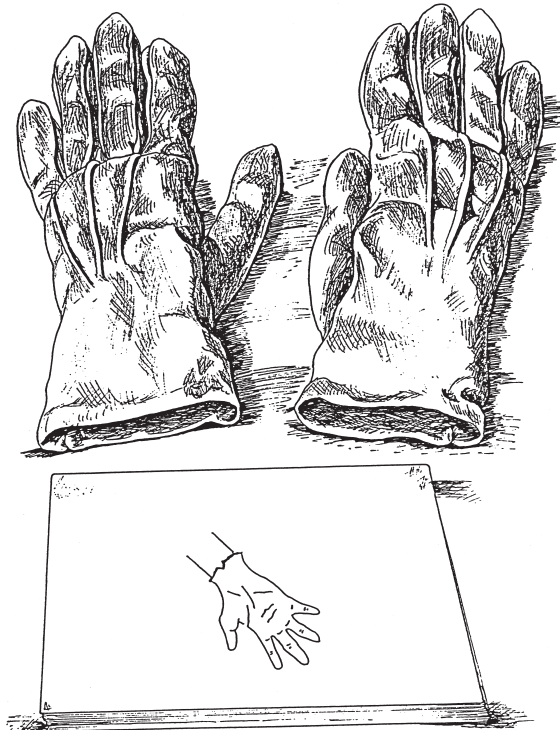

women show superior verbal memory and recall of object location. The male superiority for throwing and mental rotation is one standard deviation higher than that for women.

It has been estimated that 76 percent of right-handed men and 56 percent of right-handed women have right hemisphere dominance for spatial ability, with the clearest sex difference found for mental rotation performance (Linn and Petersen 1985; Deutsch *et al.* 1988). One explanation for this is that men were the hunters, who would range far and wide for their prey and would therefore need to develop a highly tuned set of navigational skills. Women, the child-bearers and rearers, stayed at home and foraged. Some argue that women's ranging was limited to picking plants; men would hunt for game.

According to Ecuver-Dab and Robert (2004), this dichotomy suggests that rather than showing a superior spatial advantage by men over women, it shows how context can affect the way in which each sex expresses its specific spatial skills: spatial cognition in men would be used to navigate the environment for a mate and food, whereas women's spatial cognition developed to deal with immediate or proximal environments because they were more greatly concerned with the survival of their offspring in the home and therefore had no need to develop the navigational spatial skills that men did. In short, men developed and evolved large-scale navigation mechanisms, and women evolved small-scale ones. Ecuver-Dab and Roberts cite evidence from recent studies to support the hypothesis. Women, for example, are more likely than men to use landmarks when giving map directions. Men are more likely to provide more cardinal references – although women are capable of doing this, they simply do not use these references as their primary source of information.

Sex and language

A commonly reported sex difference in language is that men tend to exhibit a greater right visual field (RVF) advantage when responding to words presented to the left and right visual fields. That is, information received by the left hemisphere (via the right visual field) is processed more quickly in men (Boles 1984). However, the RVF advantage seems to be dependent on task instructions to respond quickly and accurately (Cornier and Stubbert 1991). The results receive some support from neuroimaging studies showing greater left hemisphere activation in men when completing language tasks but a more symmetrical pattern of activation found in women (Pugh *et al.* 1996). However, some studies have reported no difference between the sexes or have found left activation in both (Frost *et al.* 1999).

The neuroimaging literature on sex differences in language processing is a mixed one: some studies show that women have language represented more bilaterally than do men, some the opposite, and some find that the typical left asymmetry is common to both sexes. Knaus *et al.* (2004), for example, found greater leftward asymmetry in the planum temporale in women. To determine whether sex differences are genuinely reliable findings or are specific to certain studies and their methods, Sommer *et al.* (2004) meta-analysed fourteen functional imaging studies comprising 377 men and 442 women. They found no evidence for a sex difference in brain activity during language processing.

Discussing reasons for the previously reported sex difference, the authors note that such studies tended to be based on smaller samples than those reporting no difference. Some have suggested that only tasks with a phonological component reveal sex differences (this was not supported by the meta-analysis) or that only tasks using real words rather than non-words do, although the only two studies in the meta-analysis to show a sex difference used non-word stimuli. There was no difference in outcome when productive and receptive tasks were analysed, i.e. whether participants had to read aloud or silently.

Handedness

Handedness refers to the degree to which an individual preferentially uses one hand. On the surface, determining handedness might seem like a simple task, but the classification of handedness is fraught with problems (Peters 1995). The most widely used classification systems require an individual to rate the frequency of use for each hand for a number of activities, such as writing, throwing and catching a ball, threading a needle, and unscrewing a jar (Oldfield 1971; Annett 1970). Table 4.2 shows a sample from the Annett Handedness Questionnaire.

Table 4.2 The Annett Handedness Questionnaire (AHQ)

Name Age Sex

Were you one of twins, triplets at birth or were you single born?

Please indicate which hand you habitually use for each of the following activities by writing R (for right), L (for left) or E (for either).

Which hand do you use:

1. To write a letter legibly?
2. To throw a ball to hit a target?
3. To hold a racket in tennis, squash or badminton?
4. To hold a match whilst striking it?
5. To cut with scissors?
6. To guide a thread through the eye of a needle?
7. At the top of a broom while sweeping?
8. At the top of a shovel when moving sand?
9. To deal playing cards?
10. To hammer a nail into wood?
11. To hold a toothbrush while cleaning your teeth?
12. To unscrew the lid of a jar?

If you use the right hand for all of these actions, are there any one-handed actions for which you use the left hand? Please record them here

.....

Source: Annett 1970.

If individuals use the right or left hand exclusively to perform these tasks, then there may be no problem in classifying them as right- or left-handed. However, if an individual writes with the left hand and throws a ball with the right or writes with the right hand and throws a ball with the left, how should this person be classified? One solution is to classify according to the degree and strength of handedness (strong/weak hand preference). Even this is problematic, however. Peters (1992), for example, argues that, depending on the length of the questionnaire and the classification method used, the percentage of individuals classified as non-right-handers in the same sample can range from 9.4 to 86.7 percent.

Handedness exerts an important influence on hemispheric asymmetry because of the likelihood that left- and right-handers have their language regions organized differently in the brain. Based on Wada test performance and the language performance of those with unilateral brain damage, the majority of right-handers have left hemisphere speech. Most left-handers also have left hemisphere speech, but some also have right hemisphere or bilateral represented language (Goodglass and Quadfasel 1954; Segalowitz and Bryden 1983). According to Rasmussen and Milner (1977), 96 percent of their right-handers and 70 percent of their left-handers showed left hemisphere speech impairment following the injection of sodium amyta; 4 percent of right-handers had right-hemisphere speech. Segalowitz and Bryden (1983) also estimate that the left hemisphere is language-dominant for 95.3 percent of right-handers but for only 61.4 percent of left-handers. This said, however, there appears to be no significant difference between the rate or degree of recovery of language for left- and right-handers with unilateral brain damage.

Left-handers appear to be superior to right-handers on tests of verbal ability as measured by performance on the verbal IQ range of subtests on the Wechsler Adult Intelligence Scale (WAIS) but inferior to right-handers on tests of visuospatial ability as measured by performance on the performance IQ subtest of the WAIS (Levy 1969). Levy explained this in terms of a crowding hypothesis. Left-handers, Levy argued, have superior verbal ability because they have more variable language representation and have a greater neural mass devoted to language, hence their superior performance. However, because the right hemisphere is undertaking part of a function (language) considered to be the prerogative of the left hemisphere, it has less neural mass to devote to its own specialization, visuospatial ability. This is an interesting hypothesis, although the inclusion of a very small sample of undergraduates as participants in this study suggests that caution is necessary in interpreting these results.

Whether left-right-hand differences are really associated with differences in verbal and spatial ability is not exactly clear. An early review by Hardyck and Petrino (1977) concluded that there was no reliable, systematic difference between left- and right-handers for cognitive ability, although Hicks and Beveridge (1978) point out that this might apply only to tests of crystallized intelligence (knowledge tests). When tests tapping fluid intelligence (problem solving, creativity) are used, left-handers perform significantly better.

One particular aspect of handedness that may be detrimental to task performance is familial sinistrality (FS), a family history of left-handedness. In general, left-handers with FS perform more poorly than right-handers and left-handers with no FS on tests of non-verbal ability but not on tests of verbal ability (Bradshaw *et al.* 1981). Left-handers with FS also perform more poorly on mathematics tests than do weak left-handers and strongly left-handed individuals with no FS (Searleman *et al.* 1984). The conclusion from these and other studies is that FS combined with strong left-hand preference has a detrimental effect on visuospatial ability (McKeever 1986, 1991; O'Boyle and Benbow 1990), although this conclusion is not entirely accepted. Van Strien and Bouma (1995), for

example, found that left-handers with a family history of sinistrality were better at tests of numerical reasoning, verbal reasoning and two visuospatial tasks than were left-handers without a history of sinistrality. Two possible explanations for this might be that (1) there is no detrimental effect of familial sinistrality, or (2) different tests designed to measure the same factor produce inconsistent findings. The authors suggest that the latter cannot be ruled out.

Handedness, language and neuroimaging

One of the most well-established findings in the localization of function is left hemisphere-based language processing (such as Broca's area and Wernicke's area). This localization is greater in right-handers. However, this evidence has come from patients or from neuroimaging studies with small samples. Recently, a large sample ($N = 188$) of moderate and strong right-handers was studied in order to determine the strength of localization in this group (Knecht *et al.* 2000). The participants' task was to think of as many words beginning with a given letter: 92.5 percent of the sample showed left hemisphere language, with 7.5 percent showing right hemisphere activation during the language task. There was no difference in lateralization between men and women, and there were no differences in task performance between the sexes.

While the study shows a slightly greater number of individuals with right hemisphere language, there was no scope for measuring the effect of degree of handedness on lateralization: 75 percent were strongly right-handed, and the remainder were moderately right-handed. The percentage of right-handers with right hemisphere speech was similar to that reported in a previous study of language lateralization in patients with epilepsy (Springer *et al.* 1999).

Knecht *et al.* (2000) measured brain activity in 326 left- and right-handed individuals, who were required to name as many words as possible beginning with a given letter. As left-handedness increased, so did increased activity in the right hemisphere during word generation, suggesting that the degree of left-handedness is related to right hemisphere speech.

Why did this handedness difference emerge? There are some psychologists who have argued that human language evolved from gesture. These gestures are 'behavioural fossils' that accompany speech. Michael Corballis, for example, argues that the proposition that language is gestural in origin might explain the relationship between handedness and cerebral asymmetry for language, of which more later (Corballis 1999). Corballis cites evidence showing that right-handers primarily gesture with their right hand (which may not be surprising) but that left-handers (who have primarily left-hemisphere-based speech but show a more diverse pattern of localization with some having speech in both hemispheres, or the right hemisphere), gesture with both hands. The logical consequence of the gestural hypothesis is that it was not language that distinguished *Homo sapiens* from other primates but our ability to vocalize our communication instead of gesturing it.

The right-shift theory

One theory of handedness suggests that the distribution of differences between the skills of both hands is determined by a single gene (Annett 1985). Individuals who possess the rs+ allele have their hand distribution shifted to the right; their left hemisphere becomes

dominant for speech. Individuals with the rs++ gene show an even greater shift to the right hand (these individuals are called homozygotes), whereas those with the rs+- gene show a lesser degree of hand dominance (these individuals are called heterozygotes). Those without the rs+ allele (who express the rs- genotype) will show no overall bias in hand dominance.

This theory is called the right-shift theory because it suggests that a single gene shifts dominance to one hand (this oversimplifies a complex theory but is basically correct). Annett's theory is important because it suggests a relationship between hand skill and language (and even cognitive) ability. For example, Annett's theory predicts that heterozygotes (those with the rs+- allele) will be more advantaged on some skills than others and that homozygotes (those with the rs++ or the rs- - allele) and those with the rs+ gene absent, will be disadvantaged.

Annett and her colleagues (Annett and Manning 1990; Annett 1992) have shown that extreme left- and right-hand dominance in hand skill is associated with poorer reading ability than is intermediate hand skill. Annett (1993) also reported that children with intermediate hand skill were more likely to be selected for elite schools in the UK. Individuals with the least bias to dextrality perform better in terms of arithmetical ability and spatial skill (Annett and Manning 1990; Annett 1992).

However, research from other laboratories has not found unequivocal evidence for Annett's theory. For example, McManus *et al.* (1993) assessed the handedness and intellectual ability of medical students and examined differences between three degrees of right-handedness, from weak to strong preference. They found no evidence of cognitive advantage or disadvantage between weak, intermediate and strong right-handers. Similarly, Resch *et al.* (1997) administered a series of cognitive ability tests to 545 students, whose hand preference they also measured. They found that although those at the left end of the handedness continuum showed the poorest spelling, non-verbal IQ and educational success, there was no difference between this group and an intermediate and right-handed group, whereas Annett's theory might predict that strong right-handers would also exhibit poorer language ability. Palmer and Corballis (1996) have also found no relationship between hand preference and reading ability in 11–13-year-old children. Instead, reading ability was predicted by the *overall* level of hand skill rather than by the skill difference between hands.

Others have criticized Annett's model for other reasons. For example, Provins (1997) argues that handedness is a product of motor learning and environmental pressure. What is genetically determined, Provins argues, is not handedness but the motor capacity that could produce left- and right-hand preference, depending on the environment. Other critics, such as Corballis (1997b), have queried whether a single gene locus for handedness is reasonable: although the data would seem to fit a single-gene model, most genes have several loci.

McManus (1985) has proposed that what is important is not hand *skill*, as Annett's model suggests, but hand *preference*. He proposes that a dextral allele (D) predisposes us towards right-hand preference, while a chance allele (C) produces no directional bias. Individuals with the D allele (DD genotype) will develop a right-hand preference, whereas those with the C allele (CC genotype) are equally likely to show left- or right-hand preference. Both models have attracted interest from researchers investigating the relationship between handedness and cognitive/language ability. Neither has fully explained this relationship, but they provide an explanatory framework in which such relationships could operate.

Interhemispheric communication: callosal syndromes

What is a callosal syndrome?

The cerebral hemispheres are not entirely independent structures. There are direct neural associations between brain regions that allow the brain to engage in the active and effective transfer of information from one region directly to another simultaneously. If these links are broken or obstructed, certain behavioural problems manifest themselves. Wernicke, for example, found that severing the connections between the posterior and anterior speech areas produced a type of speech disorder called conduction aphasia. When this happens, a disconnection is said to have occurred: the severance of neural connections between two brain areas that does not in itself damage those areas. The behavioural symptoms seen following such disconnections are called disconnection syndromes.

The clearest example of brain disconnection is produced by commissurotomy. Here, the commissures connecting various brain structures are severed surgically for medical reasons. The largest of these commissures is the corpus callosum (CC), the mass of fibre connecting the two cerebral hemispheres. When this structure alone is severed, the procedure is called a callosotomy. Sometimes there is a partial split, where only a certain region of the corpus callosum, for example the anterior half, is lesioned. When other commissural fibres such as the anterior commissure, the dorsal and ventral hippocampal commissures and the basal telencephalic commissures are also severed, the process is called commissurotomy.

When these commissures are severed, certain irregularities appear in the way that patients process information. These irregularities make up the callosal syndromes. The term is in the plural because lesions to different parts of the corpus callosum and damage to specific commissures produce different symptoms (these are reviewed later in the chapter). Although it is the most striking cause of a disconnection syndrome, the commissurotomy is not the only means by which transfer of information can be prevented. Diseases (e.g. thrombosis, tumour) can cause a partial disconnection between brain regions owing to lesions to the corpus callosum.

One of the earliest reported cases of a split brain was that reported by Dejerine (1892). This patient had a left occipital infarct and a minor lesion to the posterior part of the corpus callosum. Puzzlingly, he could write but could not read and could name objects and numbers but could not name a single letter. This unusual presentation of behaviour is discussed in the section on symptoms. Another fascinating phenomenon is that of callosal agenesis, the congenital absence of parts or all of the corpus callosum. More fascinating still, these individuals do not show the same behavioural irregularities as commissurotomy patients.

Commissurotomy: a brief history

Early evidence indicated that epileptic seizures made their way from one hemisphere to the other in monkeys via the corpus callosum (Erickson 1940). Later that decade, surgical procedures were undertaken to sever the human commissures in order to relieve the

symptoms of epilepsy. However, the outcome was variable, with some patients showing no improvement. Soon after the mixed effects of the surgery became known, the behavioural significance of the corpus callosum was questioned. In fact, McCulloch (1949) mused that the corpus callosum was there to allow the spread of epileptic seizures, whereas Lashley (1951), perhaps tongue in cheek, proposed that the structure existed to prevent the two hemispheres from sagging.

However, it was the later work of Myers and Sperry and their colleagues in the late 1950s that prompted a re-evaluation of the role of the commissures in behaviour. In their famous experiments with cats, visual information that was presented to one cerebral hemisphere appeared to be unavailable to the other (Myers 1956; Myers and Sperry 1958). For example, cats taught a visual discrimination task with one eye covered were able to perform a discrimination task using either eye. When the corpus callosum and optic chiasm were severed, however, the cat trained with one eye open could perform the task with that eye, but when a patch was placed on the open eye and the occluded eye was opened, the cat was unable to do so. The authors concluded that sectioning the corpus callosum had prevented the transfer of information between the two hemispheres. In the 1960s, a series of human split-brain operations was undertaken at White Memorial Hospital in Los Angeles in order to alleviate the symptoms of epilepsy. The corpus callosum, the anterior commissure and hippocampal commissure were all severed during surgery. The results of these operations provided an unusual insight into the way that the two cerebral hemispheres processed and integrated information because they appeared to indicate that information made available to one cerebral hemisphere could not be accessed by the other, just as was seen in Sperry's cats. A discussion of this phenomenon and the behavioural effects of split-brain surgery can be found later in this chapter.

Corpus callosum

The corpus callosum is the largest nerve fibre tract connecting neocortical areas and contains around 200 million to 800 million fibres. It seems to appear only in placental mammals, becomes evident only in the fourth month of gestation and myelinates slowly. It is conventionally divided into regions called (from front to back) the rostrum, genu, body and splenium, as illustrated by Figures 4.8 and 4.9.

It is common for callosal fibres to connect homologous regions; that is, regions from one hemisphere are connected to similarly situated regions in the other hemisphere, although connections to non-homologous regions are found. The rostrum and genu make up the anterior end and connect the prefrontal areas (Pandya and Selztzer 1986). The areas just posterior to the genu connect the superior frontal area and motor area, respectively. The posterior midbody of the corpus callosum connects the somatosensory areas. More caudal regions connect the temporal–parietal–occipital areas. Sometimes, however, the somatosensory fibres and the auditory fibres may be intermixed. The splenium, the bulbous posterior one-fifth of the callosum, connects the occipital and anterior temporal regions relevant to vision and has tremendous variability in size and shape. These demarcations have been based on work with macaque monkeys (e.g. Rockland and Pandya 1986; Pandya and Selztzer 1986). The picture is slightly different in humans. Axonal diameter, for example, appears to be largest in the middle of the corpus callosum in

Figure 4.8 The divisions of the corpus callosum

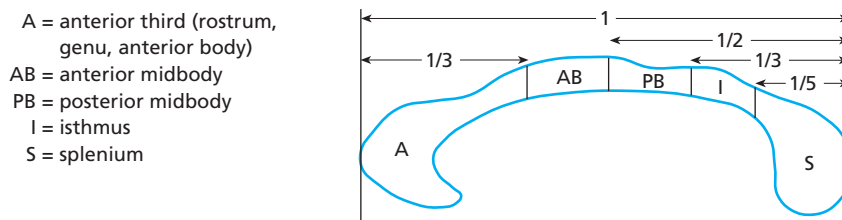
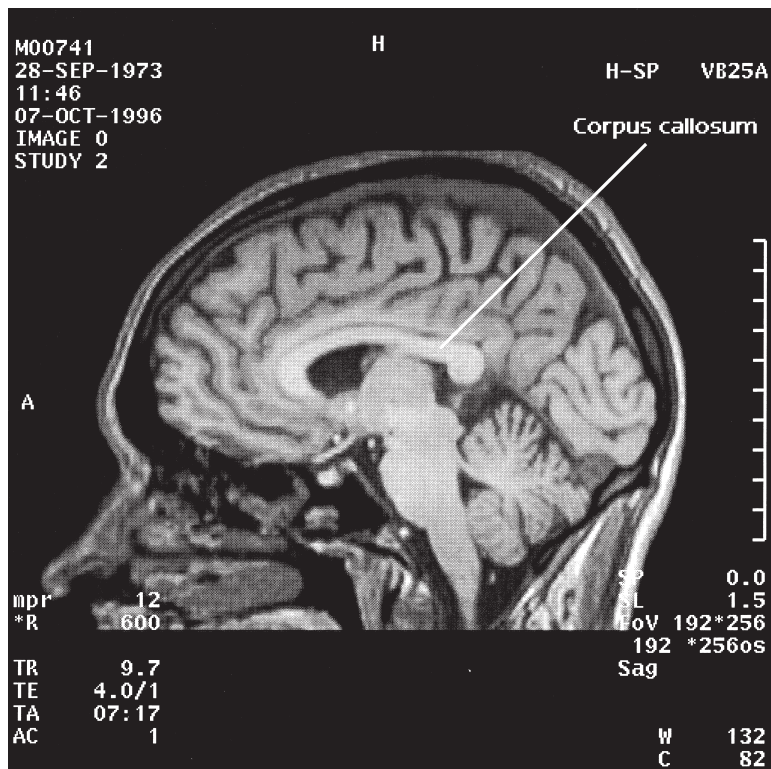

Figure 4.9 Location of the corpus callosum in the brain



macaques (Lamantia and Rakic 1990), whereas in humans, the largest fibres appear more caudally, posterior to the midbody (Aboitiz *et al.* 1992). However, the pathways of these general callosal channels are similar in both species.

It appears that the larger the size of the corpus callosum, the larger the number of fibres contained within it (Machiyama *et al.* 1987), although actual callosal connections may be limited (Kennedy *et al.* 1991). Group differences in the size of the corpus callosum have also been reported. Early studies found significant differences between the size of the corpus callosum in right- and mixed-handers: Witelson (1985), for example, reported that the corpus callosum was 11 percent larger in a group of fifteen mixed-handers than in a group of seventeen right-handers. Other studies have reported contradictory findings. Steinmetz *et al.* (1992), for example, found no interaction between sex and handedness but did find that women had a larger isthmus than men. It should be noted that many early studies, which normally used gross volume or size measures, reported no consistent sex differences. At more specific levels, such as the anterior corpus callosum or splenium, differences did emerge, with men having a larger anterior area than women (Bean 1906; although Witelson's 1985 study found no difference) and women having a significantly wider splenium (Holloway and Lacoste 1986). Given the variety of findings in the individual differences literature, however, the relative importance of the significant differences cannot be properly assessed. Furthermore, because many of the findings are contradictory, there is always the possibility that significant studies are reporting artefacts and not genuine differences.

Characteristics of split-brain patients

Split-brain patients have normal post-surgery intelligence, personality and general behaviour. In the first few days after surgery, however, they appear to have difficulty in following complex multiple commands, although each individual command is understood. Patients are often mute (Bogen 1976) and have difficulty using the left hand or arm in response to a command (the right limb performs fairly normally). The older the subject the more severe these post-operative phenomena (Lasonde *et al.* 1991). After a few months, patients perform at a normal intellectual and social level, but aspects of their behaviour are irregular: patients behave as if each of their hemispheres acts independently of the other when the patient is required to complete tests designed to examine the effectiveness of communication between the two halves of the split brain. In their extensive review of interhemispheric function, Hoptman and Davidson (1994) concluded that 'all the evidence suggests that the corpus callosum plays a significant role in high-level attentional and cognitive functions'. Generally, the patients behave as if some stimuli are inaccessible to one or other hemisphere. The most obvious examples of this are seen in experiments where objects (or names of objects) cannot be named when held by one hand (or seen in a particular hemifield).

Somatosensory effects

One of the clearest examples of the hemispheres' inability to interact effectively occurs when the split-brain patient fails to retrieve with one hand an object handled by another. For example, an unseen object can be held by the right hand and identified; however, an

object handled (or palpated) in the left hand cannot be identified. Yet when the patient is allowed to select the object from an array of objects, the left hand selects the correct object. This is sometimes called unilateral left tactile anomia or hemialexia.

Visual effects

The commissurotomized patient is also unable to read or identify stimuli presented in the left visual field but can identify the same stimuli presented in the right visual field. Sometimes the patient reports 'seeing nothing' or having seen a 'flash of light' (Bogen 1993). This phenomenon is reported after complete callosotomy but can also occur with splenium lesions (Gazzaniga and Freedman 1973; Damasio *et al.* 1980a). In a typical experiment, the patient is required to fixate on a black dot while a picture of an object (a cup, for example) is flashed briefly (100–200 ms) to the right of the dot via a tachistoscope. The patient is asked to name the object and is able to do this. The patient then fixates on the dot again while a picture of a different object (a spoon) is flashed to the left of the dot. The patient is asked to identify the object but is unable to and reports seeing 'nothing'. When allowed to select the object just seen, by touch alone, from a selection of objects, the patient's left hand chooses the spoon. When asked to identify the object, the patient replies 'spoon'.

In a similar experiment, the patient focuses on a fixation spot while a picture of a naked woman is presented to the left of it. She giggles but reports having seen nothing, 'just a flash of light'. These responses were made by a female patient, NG, one of several split-brain patients studied by Sperry and his colleagues (Gazzaniga *et al.* 1962; Sperry 1968; Sperry *et al.* 1969). Although the patient can see and identify stimuli presented in the right visual field (information going to the left hemisphere), material presented to the left visual field also appears to be 'seen' because the patient giggles when the naked woman is presented and correctly identifies the object presented in the left visual field when allowed to select it from a group of objects. Two possible explanations for this phenomenon might be that the patient may not be able to provide the object with a verbal label or that she may not have been consciously aware of the object being presented. This type of anomia is not exclusive to the visual domain and is present even for olfactory stimuli. For example, commissurotomized patients are unable to identify odours presented to the right nostril but can identify those presented to the left nostril, despite having no lesions to the olfactory apparatus (Gordon and Sperry 1969). The pathway from nostril to hemisphere is ipsilateral (unlike many of the other senses'), so an odour presented to the left nostril is processed by the left hemisphere.

When images of arcs are presented to the right hemisphere and the patient's task is to indicate which different sizes of circle would be made up of the arcs, patients perform significantly better than when stimuli are presented to the left hemisphere (Nebes 1972). This indicates that the perception of part/whole relations appears to be better in the right hemisphere of commissurotomized patients. Similarly, Franco and Sperry (1977) found that the right hemisphere was better at matching touched, unseen objects with geometric shapes presented in free vision: a superiority that increased as the shapes became less geometric and more free-form. The split-brain patient also appears to see whole figures or shapes when there are in fact different or fractured shapes. Patient NG was presented with a chimeric face (where each half of the face is made from a different face) and instructed to name the right as Dick and the left as Tom. When the chimera was presented to her and she was asked which face she saw, she indicated Dick. When asked to identify the face by pointing with either hand to a series of faces, she identified Tom (Levy *et al.* 1972).

Other symptoms

The earliest documented symptom of commissurotomy was the inability to follow commands to move with the left limb. This disorder, regardless of the side affected, is called apraxia, as is discussed in more detail in Chapter 7. Commissurotomized patients have difficulty following commands to make a fist or wriggle fingers with the left hand (the right performs these normally), probably because the ipsilateral control of this limb by the left hemisphere is poor or because the right hemisphere is poor at comprehending the instructions. Sometimes in split-brain patients, the hands appear to behave in a contradictory manner – there is intermanual conflict. For example, one patient was observed doing up the buttons on a shirt with one hand and undoing the buttons with the other (Akelaitis 1944/45). A similar phenomenon is illustrated by a patient who selected one necktie with one hand but a different tie with the other.

A related, but different, symptom is *la main étrangère* or alien hand (Brion and Jedynak 1972). Here, the patient believes that one of his or her hands (usually the left) is behaving in an odd, uncooperative or alien way. The patient may even castigate the hand for behaving in a peculiar way. One reason why the alien hand phenomenon occurs, may be that the inhibition of actions organized elsewhere, but that originates in the frontal cortex, is lost (Della Salla *et al.* 1991).

Compensatory actions

In order to try to circumvent the problems brought about by these symptoms, commissurotomized patients sometimes adopt compensatory strategies that help them to perform better. For example, if they are unable to name a handled object such as a comb, they may run their fingers along its teeth, which produces a noise picked up by both hemispheres. Explanations for these types of recovery suggest either that the right hemisphere is gradually acquiring speech or that information may be being conveyed from one hemisphere to another via unsevered commissures. However, Gazzaniga and Hillyard (1971) had an alternative explanation. They argued that patients used whatever cues were available to them in order to identify an object (as in the comb example above). This was called cross-cueing. However, the recovery seen in JW is unlikely to have resulted from cross-cueing and is more likely to be due to some form of transfer of information between the two hemispheres.

Interhemispheric transfer: callosal channels?

Although the commissurotomized patient suffers massive loss of tissue connecting the two halves of his or her brain, not all connections between the hemispheres are lost. There are still connections from other brain structures such as the cerebellum, pons and hypothalamus, i.e. the subcortical connections are still intact. Similarly, the split-brain operation sometimes involves a partial split, where only parts of the corpus callosum are severed or where some of the other, smaller commissures are spared. This situation raises the possibility that some transfer of information may be possible because of the spared

tissue (this is the subject of the discussion point at the end of the chapter). If information is transferred from one hemisphere to another via these commissures, what form of neural organization makes this possible?

It has been argued that what these connections provide is a series of callosal channels, which convey specific types of information from one region in one hemisphere to a homologous site in another. For example, when the head of the splenium is lesioned, unilateral left anomia and apraxia occur, although the transfer of visual information is fairly normal (Risse *et al.* 1989). When the splenium and isthmus are spared, no anomia or apraxia occurs. When the splenium is completely lesioned, the transfer of visual information does not occur (Bentin *et al.* 1984).

Lesions to the genu and anterior half result in very few symptoms, although there may be impairments in areas such as hearing and somatosensation. These structures appear to be relatively unimportant for attention, because patients with anterior corpus callosum and anterior commissure lesions are able to sustain visual monitoring for up to 30 minutes. However, a complete commissurotomy is associated with impairments in visual vigilance after only 10 minutes (Dimond 1976).

Based on these observations, Levy, Trevarthen, Banich and others have proposed that the corpus callosum provides a means whereby information can be transferred either via direct channels or via a hemisphere that assumes the dominant information-processing role.

Models of interhemispheric transfer

The integration of information from two regions is assumed to occur either directly or indirectly. For example, a direct transfer route sends information directly from one region to another. This assumes some form of duplication of information, because the information sent by one region is the same as that received by another. An alternative view would be to argue that information received by two or more regions is then sent to a third area. In this way, the two areas do not directly share information but send it to a common source. This has been called third party convergence (Goldman-Rakic 1988). A further alternative would be to suggest that information is sent from two regions but this time is sent on to several different regions. In this model, non-convergent temporal integration, there is no grand convergence zone where all projections meet – a very similar phenomenon to that seen in the visual system, where there are two distinct, independent neural pathways. There are examples of all of these types of inter- and intra-hemispheric connection in the brain.

Levy and Trevarthen's metacontrol

In an early study of four commissurotomy patients, Levy and Trevarthen (1976) found that the hemisphere that was assumed to be superior for a specific function was not always the hemisphere that undertook that function. More generally, the hemisphere taking control was not always the one with the greater ability. They called the mechanism underlying this 'metacontrol': 'the neural mechanisms that determine which hemisphere will attempt to control cognitive operations'. They distinguished between hemispheric ability (the degree of success that a hemisphere showed in performing a task) and hemispheric dominance (the degree to which one hemisphere takes control). This mechanism,

argued Levy and Trevarthen, might explain how the two cerebral hemispheres behave when the same information is available to both hemispheres and suggests that one hemisphere's mode of control will dominate behaviour.

Joseph Hellige, at the University of California, has made an attempt to establish whether metacontrol may also occur in neurologically intact individuals (Hellige 1991). In a series of experiments, he and his colleagues found that the left hemisphere was the dominant hemisphere for some but not all tasks when information was available to both hemispheres (Hellige *et al.* 1989; Hellige and Michimata 1989). Furthermore, as predicted from Levy and Trevarthen's data, the dominant hemisphere was not always the hemisphere specialized for undertaking the task.

Banich's model of interhemispheric processing

Banich's (1995) model also attempts to explain interhemispheric transfer in terms of metacontrol and proposes that (1) the transfer of information occurs via channels provided by the corpus callosum and subcortical commissures; (2) the hemispheres interact, but only one assumes a dominant role in this interaction; and (3) callosal channels allow for more efficient processing of complex information than would one hemisphere alone. The model suggests that two types of information do not require transfer: emotional information and aspects of spatial attention. The findings, including those of Hellige, suggest that the types of interhemispheric transfer possible are many. For example, in an experiment in which the subject was presented with two numbers either to the left visual field (LVF), the right visual field (RVF) or both and was required to indicate whether either number was less than a previously presented target number, LVF trials showed no significant difference between the speed of responding yes or no (Banich 1995). However, reaction times for the RVF were significantly different ('yes' was faster), a finding repeated when the stimuli were presented bilaterally. On some trials, regardless of whether the two numbers were identical (e.g. target of 12 followed by 17, 17) or not (e.g. target of 12 followed by 17, 14), both were larger than the target number. Banich and her colleagues found that bilateral trials were similar to the LVF trials but dissimilar to the RVF trials. Responses were significantly faster in the RVF for the same digit/same decision trials than the different digit/same decision trials. However, what appears unclear is which factors influence the similarity (or dissimilarity) between interhemispheric processing and single-hemisphere processing.

Cook's model of corpus callosum function

Cook's model of corpus callosum function suggests that the corpus callosum serves to inhibit neural activity topographically (Cook 1984a, b). That is, inhibition in the corpus callosum suppresses the same pattern of neuronal activity in one hemisphere that had originated in the other. However, the structure does not inhibit neural activity in surrounding areas (which may relate to the function performed). Thus neurons in the left hemisphere may respond to a specific word (e.g. 'spoon'), but inhibition by the corpus callosum prevents the right hemisphere from accessing the information. However, the surrounding excitation allows the transfer of semantic information related to that object. Therefore, information such as eating, fork, soup would still be accessed. However, Woodward (1988) suggests that processing in the left hemisphere relies on connections

between strong vertical neuronal columns, whereas the right hemisphere relies on weaker, horizontal connections. The corpus callosum inhibits vertical neurons, thus allowing horizontal connections to be utilized. There is no evidence of this occurring between the hemispheres, although it is feasible that one type of neuronal circuitry may be more greatly utilized in one hemisphere than the other. Both Woodward's and Cook's models propose some form of inhibition, and both suggest that the pattern of activity in one hemisphere is suppressed in the other by the corpus callosum. However, evidence for both is weak.

Discussion point: can the hemispheres of a split-brain patient still transfer information?

The evidence considered in the chapter so far indicates that interhemispheric transfer of information in split-brain patients is, if not absent, then difficult to achieve. However, we have also seen how cortical lesions do not affect the functioning of subcortical connections. These remaining fibres can still allow one hemisphere to communicate with the other. Trevarthen (1987) suggested that the other hemisphere's access to information was implicit, (unconscious), and not explicit, (conscious).

In a series of extensive studies with split-brain patients, Sergent (1987, 1990, 1991) has suggested that even complex information can be transferred interhemispherically in split-brain patients. For example, she found that when two stimuli were presented to both hemifields and the patient was required to decide whether (1) two lines formed a broken or a single line, (2) the angle made by two arrows was greater or less than 90 degrees when combined, (3) the total number of dots presented bilaterally was odd or even, (4) the sum of two digits was less or greater than 10, or (5) a four-letter string (two letters to each hemifield) formed a word, patients were able to make correct decisions (Sergent 1987). When asked to describe the arrows or name the letters presented, however, the patients could not make a correct response. A follow-up study demonstrated similar interhemispheric communication ability (Sergent 1991). In these experiments, patients were required to indicate which of two circles, one presented to each hemifield, was the bigger and to decide which of two oblique lines was closer to a vertical line. In the first task, two out of the three split-brain patients tested gave the correct answer. In the second task, one out of the two patients tested made the correct decision. When the task required both decisions to be made in the same task, none of the patients gave a correct answer.

However, some doubt has been cast on the reliability of Sergent's findings. Corballis and Trudel (1993) found that only one of their two split-brain patients performed above chance level using a larger set of stimuli than Sergent's. Similarly, Seymour *et al.* (1994) have published data suggesting that the corpus callosum is critical for the transfer of sensory and high-level information. For example, they draw attention to the fact that studies in which a successful transfer of information is reported have done so using a small group of split-brain patients, specifically patients LB and NG. These authors also question the completeness of the callosal section in one of these patients (LB). This patient showed evidence of small patches of substance in the splenium during the testing undertaken by Sergent (1987), although a more recent MRI scan indicates complete section. Also, this patient's behaviour is

similar to that of control subjects (Lambert 1991). Because of this, Seymour *et al.* argue, LB is not very representative of split-brain patients. In their study, a series of four experiments were undertaken by three patients (JW, VP and DR). These tasks were similar to those used by Sergent, although not all of Seymour *et al.*'s patients participated in each of the experiments. Two of the patients performed below chance levels on these tasks, indicating that no interhemispheric communication occurred. However, VP, who had some sparing of callosal fibres, showed some evidence of interhemispheric transfer.

Based on this evidence, Seymour *et al.* argue that the pattern of behavioural symptoms that characterizes callosal disconnection will emerge if patients have callosal lesions. Sparing of parts of the callosum will produce evidence of interhemispheric transfer (as seen in VP, the patient who had spared fibres in the rostrum and splenium). Also, JW, VP and DR had spared anterior commissures, which suggests that this channel may not have been effective in allowing the transmission of information. Given that one of the hypotheses regarding callosal genesis patients' accurate performance on disconnection tests argues that performance occurs because of intact anterior commissures, this is particularly relevant. However, it must be noted that all split-brain patients show considerable interindividual differences. Patient DR, for example, had her callosum sectioned seven years prior to testing. Both the other patients had undergone callosotomy thirteen years prior to testing. One patient was male (JW), the others were female (DR, VP). Similarly, some of the procedures in Seymour *et al.*'s study showed irregularities. For example, not all patients undertook the same number of trials, and as mentioned above, some experiments included only one participant. As with all split-brain studies, conclusions have to be drawn circumspectly.

Why does hemispheric lateralization exist?

'Everything,' argues Corballis (1991), 'even a billiard ball, is asymmetrical if examined closely enough or with sensitive enough measuring instruments'. This caveat serves as a sensible reminder that asymmetry may not be functionally significant but simply reflects a physical characteristic.

Most theories of laterality focus on the role of the 'dominant' left hemisphere and its role in language production. From this focus, the development of asymmetry is seen as an evolutionary step up from non-human primates. Luria (1973), for example, suggested that the higher the function, the more asymmetric it becomes. Thus, we are more clearly lateralized because we are higher-thinking human beings. We are higher-thinking because we have language. Asymmetry thus reflects a developmental or adaptive trait. However, the question of whether asymmetry serves some adaptive role is not an easy one to answer. What, for example, is the adaptive point of right or left head turning? Is bisymmetry itself adaptive? For example, bipedal locomotion (walking on two feet) relies on symmetry – we do not walk about with one foot (Corballis 1991). The consequences of asymmetry here would clearly serve no adaptive advantage. If this is the case, however, why do humans also exhibit footedness?

Motor theory of language development

One theory of localization of speech draws on the fact that the hemisphere dominant for language is also the hemisphere that controls the dominant hand. Hemispheric localization of speech is therefore regarded as a consequence of the evolution of motor skills rather than the evolution of a mechanism allowing the manipulation of symbols or the analysis of stimuli. The majority of people are estimated to be dominant with the right hand, and we gesture primarily – and more meaningfully – with this hand. Given that our earliest means of communication was through gestures (and, later, grunting), it is hypothesized that the more sophisticated form of communication (speech) that humans now use evolved from this basic motoric base. This hypothesis led to the ‘motor theory of speech perception’, which argued that in order to perceive speech sounds, the brain acts as a sort of mimic, implicitly sounding or vocalizing the words it hears before it makes sense of them. It is also useful to note that, as the chapter on language will show, sign language is more greatly impaired by left hemisphere than right hemisphere injury.

Corballis (1989) has suggested that the evolution of flexible, dynamic and rapid delivery of speech developed only recently in evolutionary terms (150 000–200 000 years ago), whereas left hemisphere speech may have been present in our hominid ancestors two million years ago. Corballis sees the development of language (and other complex) behaviour as reflecting a process of generativity, which is left hemisphere-based (Corballis 1989, 1991). Generativity refers to the ability to combine aspects of behaviour according to given rules. Combinations could include those of words to make sentences or objects to make tools. However, this theory is complicated somewhat by the lack of systematic or grossly detrimental differences between the cognitive abilities of individuals with left, right or bilateral hemispheric language and speech.

Crowding

On a more general level, it has been suggested that because the cognitive processes used for language and spatial and perceptual functions are entirely different, then these different functions require different hemispheres to undertake them efficiently (Levy 1974, 1990). The idea behind this hypothesis is that a function is better served by one hemisphere that is specialized for that function than by two hemispheres that have to share a function and that therefore engage in unnecessary doubling of function. If a hemisphere specialized for one function is required to undertake a function it does not normally undertake (as it may do when the brain reorganizes itself after brain injury, with the homologous right regions seemingly undertaking the role of the disrupted left regions), the functions ‘crowd’ this hemisphere. This leads to disruption not only in the new function but also in the one that the hemisphere normally undertakes.

More prosaically, Brown and Kosslyn (1993) have suggested that asymmetry may be one of degree: both hemispheres are capable of undertaking any function thought to be the preserve of one hemisphere, but one can undertake the role better. The proposition is supported by data suggesting that the non-specialist hemisphere can undertake some of the functions of the disrupted hemisphere (as Chapter 13 shows), but it does not explain why such lateralization preferentially develops.

Global versus local processing

Another view of hemispheric lateralization suggests that it reflects general types of processing, with one hemisphere specialized for local processing and the other for global processing. For example, in one experiment, brain-injured participants were asked to indicate which of two letters was present in a stimulus array in which the letter was large and was made up of smaller, different letters. So, a large letter M might be made up of several little letter Rs. The participant would be asked to indicate whether the stimulus featured an M, an R or some other letter. Local processing would involve searching for the R, global processing for the M. Patients with damage to the right superior temporal gyrus were impaired at identifying the large letter (global processing), whereas patients with left-based lesions were poorer at identifying the small letter (local processing) (Marshall and Halligan 1995). The finding has been complemented by neuroimaging research also suggesting a right-sided activation when participants have to attend to the global features of a stimulus but left-sided activation when they attend to the local features (Fink *et al.* 1996). At a general level, therefore, there appears to be some merit in the proposition that the right and left hemispheres are specialized for global and local information processing, respectively. At the specific level, however, the pattern is less evident. There is no right hemisphere superiority for whole words over individual letters, for example, so perhaps the local/global distinction is function-dependent.

Furthermore, it seems as if hemispheric superiority for local and global processing may be eliminated by intelligence, specifically highly developed mathematical skill. Singh and O'Boyle (2004) used a hemifield paradigm to compare the ability of college students, adolescents of average ability and mathematically gifted adolescents to make global- or local-processing decisions. For the average ability sample and the college students, there was the expected left hemisphere superiority for local judgements and the expected right hemisphere superiority for global processing. However, the mathematically gifted group showed no such significant differences in asymmetry.

Geschwind and Galaburda's model

The most detailed and complex theory of functional hemispheric asymmetry was proposed by Geschwind and Galaburda (1985). They argued that the development of cerebral lateralization is influenced by levels of foetal testosterone (Geschwind and Behan 1982; Geschwind and Galaburda 1985). These levels influence the anatomical and physiological development of the left hemisphere and, perhaps more controversially, may influence the development of neuropsychological (e.g. dyslexia) and immune (e.g. asthma) disorders.

The theory argues that testosterone levels alter the growth of the left cerebral hemisphere, which in turn produces 'anomalous dominance' (Annett 1985; Geschwind and Galaburda 1987). A testosterone-induced delay in left hemisphere development may produce random dominance; that is, the individual could become left- or right-handed. This delay also brings with it an increase in immune disorders and learning difficulties.

In an extensive re-evaluation of the evidence for and against the Geschwind-Galaburda model, however, Bryden *et al.* (1994) conclude that supportive evidence is either ambiguous or sparse. Studies do show a higher incidence of left-handedness and immune disorders in dyslexics, but there is no significant difference between left-handed and right-handed dyslexics, as would be predicted by the model. On the point of handedness, Bishop (1990) has argued that it is not left-handedness that may be related to increased incidence of developmental language disorder but uncertain or ambiguous handedness. Flannery and Liederman (1995) similarly found no significant relationship

between non-right-handedness and reading disability. This study, together with the mass of studies reviewed by Bryden *et al.*, indicates that the data supporting the model are highly inconsistent and may be accounted for by alternative explanations.

Stimulus – or processing – dependence?

A common theme running throughout some of the theories considered so far is that lateralization might reflect general rather than specific processes or functions: that one hemisphere, for example, might respond better when attending to local features of a stimulus rather than its global features. This approach argues that although there may be modules in each hemisphere that are specialized for specific functions, the hemispheres in general might assist the processing of such functions in different ways. This approach had been slightly discredited in the past – the tired dichotomy of the left hemisphere as ‘analytical’ and the right as ‘holistic’ or ‘emotional’ is as vague as it is generally inaccurate. There continues to be debate over whether hemispheric differences reflect differences in cognitive processing or differences in responding to certain types of stimulus. A recent development has been the proposition that the hemispheres may contribute differently to the processes of response selection, response inhibition and the monitoring of conflicting responses – that is, the control of hemispheric function – regardless of stimulus type.

Stephan *et al.* (2003) presented two different tasks – one lexical, one visuospatial – using the same sets of words (i.e. the same stimuli) to sixteen right-handed men and used fMRI to measure brain activation during task performance. In the lexical task, participants had to ignore the colour of the letters in a four-letter word (where three letters were black and the third or fourth letters were red) and indicate whether the word contained the letter ‘A’. In the visuospatial task, participants were asked to suppress awareness of the language-related properties of the stimulus and judge whether a red letter was to the left or right of the centre of a presented word. All participants also completed a reaction time task – they responded whenever a word appeared on a monitor. If lateralization depends on the nature of the stimuli, no differences should be observed; if it depends on processing, there should be left–right differences. During the lexical task, there was significantly greater left hemisphere activation (Broca’s area, premotor cortex, extrastriate cortex, anterior cingulate cortex and supplementary motor cortex); during the visuospatial task, there was significantly greater anterior and posterior right parietal lobe activation (with no left hemisphere activation). The only common area of activation was in the primary visual cortex.

To try to identify a region that was commonly recruited in both types of task (and not during baseline), the study compared activation in the dorso-lateral prefrontal cortex (DLPFC) and the anterior cingulate cortex (ACC) during the two tasks and baseline. No differences were found in the DLPFC, but bilateral activation was found in the ACC during task performance; but this was greater in the left during the lexical task and the right during the visuospatial task, suggesting that the ACC may play an important role in mediating cognitive control.

If this were correct, however, one would expect patients with damage to this region to show impaired cognitive control. Neuroimaging studies can show only the areas of the brain that may be sufficient for behaviour, not those that are necessary. Fellows and Farah (2005) administered measures of cognitive control (derived from neuroimaging studies) to four patients with dorsal ACC damage and twelve age- and education-matched controls. The patients’ performance on these tasks was intact, suggesting that the role of the ACC in control is not as great as the neuroimaging studies suggest. Instead, its role may be that of encoding information about the likely reward that an individual would receive from a response or in controlling the autonomic responses associated with cognitive effort.

Discussion point: do left-handers die sooner than right-handers?

In 1988, Halpern and Coren published a controversial paper in the science journal *Nature* in which they examined the relationship between death rates and hand preference. Using data from *The Baseball Encyclopaedia*, which detailed the birthday, date of death, and throwing and batting hand of 2271 players, they found a difference of eight months between the mean age of death of strong right- and left-handers. This difference favoured the right-handers: right-handers lived significantly longer than left-handers and, more surprisingly, mortality rates were almost identical for the two groups up until the age of 33. From 33 onwards, the average number of right-handers surviving was higher than the average number of left-handers. An earlier mailshot survey (Porac and Coren 1981) of 5147 respondents indicated that the proportion of left-handed individuals decreased from approximately 15 percent among 20–30-year-olds to 5 percent for those in their fifties and 0 percent for those 80 years or older. A survey of 987 deceased individuals showed that right-handers actually outlived the left-handers by, on average, 8.97 years (Halpern and Coren 1990).

Why is there such a comparatively low number of left-handers in the elderly population? One explanation is that left-handers become less common because they have learned to become right-handed through environmental pressure. This is called the modification hypothesis. A second, more controversial explanation argues that left-handedness becomes less prevalent because left-handers have ‘disappeared’. The most obvious reason for this disappearance, Coren argues, is death. This is called the elimination hypothesis, and it is this that is the source of the controversy.

In a review of handedness and mortality, Coren and Halpern (1991) argued that there is little evidence for the modification hypothesis, but there was considerable empirical support for the elimination hypothesis. Left-handedness may be a marker for increased risk of early mortality or ‘reduced survival fitness’. To account for the greater risk in left-handers, they suggest a number of explanations. One is the right-sided world hypothesis: left-handers continually have to adjust to right-handed tools and environments. Consequently, they are clumsy and cause accidents.

To test this hypothesis, Coren (1989) asked a sample of 1896 university students to indicate their handedness and the number of accidents they had experienced in the past two years while (1) using tools or implements, (2) driving, (3) at home or at work, and (4) participating in some sporting activity. He found that left-handers were at increased risk of accidents in all of these categories: in fact, they were twice as likely to have sustained accident-related injuries than were right-handers. All of this evidence appeared to indicate that left-handedness was potentially life-threatening, or life-shortening. Or did it?

In a reply to Coren and Halpern’s (1991) review, Harris (1993) questioned many of the assumptions underlying Coren’s findings and the quality of the data collected. In Porac and Coren’s (1981) study, for example, approximately 20 000 individuals were included in the initial sample, yet only 5147 individuals’ responses were selected. There were also large differences in the composition of each of the eight age groups: 292 individuals in the 10–20 age group, 3409 in the 20–30 age group, 468 in the 30–40 age group, 278 in the 40–50 age group, 361 in the 50–60 age group, 213 in the 60–70 age group, 89 in the 70–80 age group and 37 in the 80+ age group. The small size of these last two groups indicates that they may not have been representative. Harris

suggests that other studies (e.g. Ellis *et al.* 1988; Lansky *et al.* 1988) whose return rates were substantially higher (82 percent returned their questionnaires in Ellis *et al.*'s sample) are a better reflection of population trends. These studies, although showing the same pattern as the Coren data, did not show such large handedness differences. Furthermore, setting aside questions of hand preference measurement, Harris argues that the baseball player study omitted 563 players who changed hands in batting or who had mixed handedness. Furthermore, two other studies using larger samples of baseball players reported contrary results (Wood 1988; Anderson 1989). The mean difference in the age of death of left- and right-handers in the Wood study was one month. In the Anderson study, there was a right-hand advantage for longevity for players born before 1890 but a left-hand advantage for players born later. Aggleton and colleagues also reported an apparent right-hand advantage for longevity but qualified this finding (Aggleton *et al.* 1993). They analysed the lifespan of 2580 right-handed and 585 left-handed first-class cricketers and found that the right-handers lived an average of 25 months longer, as Figure 4.10 illustrates.

However, this difference appeared to be attributable to the cause of death: the left-handers who died early died either of unusual causes and prematurely or due to warfare. When the deaths resulting from these causes were removed from the analysis, no difference in mortality remained between right- and left-handers (Aggleton *et al.* 1994).

Figure 4.10

The longevity of left- and right-handed cricketers (from Aggleton *et al.* 1993. Reproduced with permission from the BMI Publishing Group)

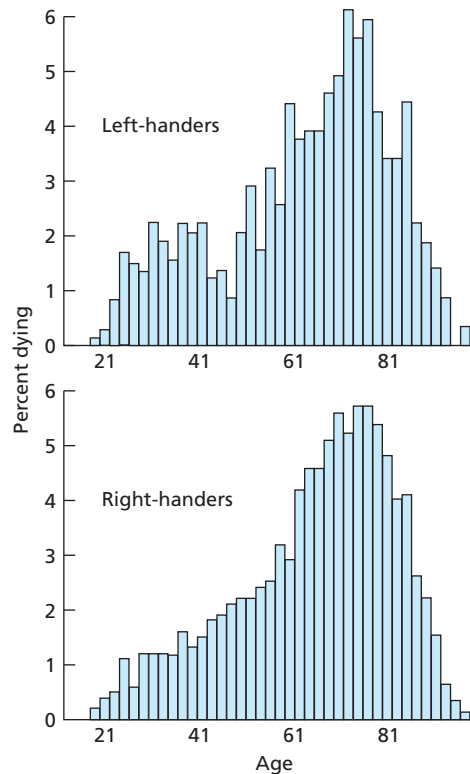

The next-of-kin study has been criticized for the use of *post mortem*, subjective assessment of handedness. The accident-related injury indicated that the only category of accident showing a statistically significant difference between right- and left-handers was driving, and this finding was qualified by an interaction between sex and handedness: left-handed men reported more accidents. Beaton *et al.* (1994) found that the incidence of hand injury reported at an accident and emergency hospital unit was slightly higher for left- than for right-handers. It appears that when injury reports consider ambidexterity (and not simply right- and left-handedness) ambidexters report a greater number of accidents than right- or left-handed individuals (Daniel and Yeo 1991).

The debate continues. Ellis and Engh (2000), in one of the largest studies of its kind, compared the death rates of 5743 individuals in the USA and Canada but, instead of dividing the sample into right- and left-handers, they differentiated handedness into five types: extremely right-handed, generally right-handed, ambidextrous, generally left-handed, extremely left-handed. Based on this differentiation, one category was found to be significantly disadvantaged. Those described as generally left-handed died at a younger age than those in the other four categories.

Based on the available data, there is no absolute answer to the question of why left-handers die sooner than right-handers but there is strong evidence that left-handedness becomes less prevalent in later years of life.

Summary

Hemispheric asymmetry refers to the degree to which one hemisphere may be dominant for a specific function such as language. Terms used interchangeably to describe the same phenomenon include laterality, hemispheric specialization, functional asymmetry and hemispheric dominance. If a function is said to be the responsibility of one hemisphere, that function is said to be lateralized. Human neuroanatomical asymmetries include two gyri (Heschl's gyri) in the right primary auditory cortex and one in the left in the majority of right-handed humans. The right is also doubled-over. The right hemisphere is larger and heavier than the left. The planum temporale, a structure in the Sylvian fissure posterior to the primary auditory cortex, is larger on the left than on the right. This may be involved in language, the most clearly lateralized higher function. Visuospatial ability is associated with right hemisphere dominance. Spatial ability may be more lateralized in the right hemisphere in men than in women. Men consistently outperform women on tests of mental rotation. Handedness also interacts with sex such that left-handed men may perform differently from right-handed men or left- or right-handed women. The callosal syndrome is a term used to describe the behavioural symptoms presented following severance of the corpus callosum. Fibres that connect regions of one hemisphere with regions of another are called commissures. When the corpus callosum, a large commissure connecting the two hemispheres, is severed, the surgery is called a callosotomy. When other commissures as well as the corpus callosum are severed, the procedure is called a commissurotomy. Individuals who have undergone this surgery are commonly described as split-brain patients. These patients have difficulty following simple commands using the left hand, are mute and demonstrate some unusual behaviour under laboratory conditions. This behaviour is somatosensory, visual, apraxic, auditory, attentional and compensatory in nature. Patients are unable to name an object held and palpated by the left hand,

although they can with the right hand. They are unable to read or identify stimuli presented to the left visual field but can do so when stimuli are presented to the right visual field. Transfer of information may occur either directly between one region and another, or indirectly, where two regions project to a common target area, or two areas project to two different areas that project to two other, different areas. Recent studies indicate that commissurotomy patients can perform well on tasks that make bilateral demands on the patients, perhaps owing to spared subcortical commissures. However, studies in which patients with spared subcortical commissures were examined show the typical disconnection syndrome. One theory of hemispheric asymmetry explains the phenomenon in terms of superior evolution: the more sophisticated the task, the greater the hemispheric asymmetry observed. Another suggests that left hemisphere speech is an extension of the left's motor control of the dominant, contralateral hand. Some evidence suggests that the incidence of left-handedness declines in the population in later years. The reasons for this are unknown.

Recommended further reading

Lateralization of function

- Beaton, A.A. (1997). The relation of planum temporale asymmetry and morphology of the corpus callosum to handedness, gender and dyslexia: a review of the evidence. *Brain and Language*, 6, 2, 255–322.
- Bryden, M.P., McManus, I.C. and Bulman-Fleming, M.B. (1994). Evaluating the empirical support for the Geschwind–Behan–Galaburda model of cerebral lateralization. *Brain and Cognition*, 26, 103–67.
- Cortex (2006). Forum on evolutionary and comparative approaches to the study of cerebral lateralization. *Cortex*, 42, 1.
- Cowey, A. (2001). Functional localization of the brain. *The Psychologist*, 14, 5, 250–54.
- Driver, J. and Frackowiak, R.S.J. (2001). *Imaging Selective Attention in the Human Brain*. Oxford: Academic Press.
- Frith, C.D. and Frith, U. (1999). Interacting minds – a biological basis. *Science*, 286, 1692–5.
- Geschwind, N. and Galaburda, A.M. (1985). Cerebral lateralization: biological mechanisms, associations, and pathology. Parts I, II and III. *Archives of Neurology*, 42, 428–59, 521–52, 634–54.
- Halpern, D.F. (1996). Sex, brains, hands and spatial cognition. *Developmental Review*, 16, 261–70.
- Hugdahl, K. (1996). Brain laterality: beyond the basics. *European Psychologist*, 1, 3, 206–20.
- Josse, G. and Tzourio-Mazoyer, N. (2004). Hemispheric specialization for language. *Brain Research Reviews*, 44, 1–12.
- Marshall, J.C. and Fink, G.R. (2003). Cerebral localization, then and now. *Neuroimage*, 20, S2–S7.
- Nichols, M.J. and Newsome, W.T. (1999). The neurobiology of cognition. *Nature supplement*, 402, C35–C38.
- Posner, M.I. (2004). *Cognitive Neuroscience of Attention*. Hove, UK: Psychology Press.
- Provins, K.A. (1997). Handedness and speech: a critical reappraisal of the role of genetic and environmental factors in the cerebral lateralization of function. *Psychological Review*, 104, 3, 554–71.
- Snyder, P.J. and Harris, L.J. (1997). An intracarotid amobarbital procedure: an historical perspective. *Brain and Cognition*, 13, 18–32.
- Springer, S.P. and Deutsch, G. (2000). *Left Brain, Right Brain* (5th edition). New York: W.H. Freeman.

- Van Lancker, D. (1997). Special issue of *Brain and Language* on 'Current studies of right hemisphere function'.
- Vogel, J.J., Bowers, C.A. and Vogel, D.S. (2003). Cerebral lateralization of spatial abilities: a meta-analysis. *Brain and Cognition*, 52, 197–204.
- Voyer, D. (1998). On the reliability and validity of noninvasive laterality measures. *Brain and Cognition*, 36, 209–36.

Callosal syndromes

- Banich, M.T. (1995). Interhemispheric processing: theoretical considerations and empirical approaches. In R.J. Davidson and K. Hugdahl (eds), *Brain Asymmetry*. Cambridge, Mass.: MIT Press.
- Catani, M. and Ffytche, D. H. (2005). The rises and falls of disconnection syndromes. *Brain*, 128, 2224–39.
- Gazzaniga, M.S., Bogen, J.E. and Sperry, R.W. (1962). Some functional effects of sectioning the cerebral commissures in man. *Proceedings of the National Academy of Sciences*, 48, 1765–9.
- Hoptman, M.J. and Davidson, R.J. (1994). How and why do the two cerebral hemispheres interact? *Psychological Bulletin*, 116(2), 195–219.
- Liederman, J. (1995). A reinterpretation of the split-brain syndrome: implications for the function of corticocortical fibres. In R.J. Davidson and K. Hugdahl (eds), *Brain Asymmetry*. Cambridge, Mass.: MIT Press.
- Sergent, J. (1987). A new look at the human split brain. *Brain*, 110, 1375–92.
- Seymour, S.E., Reuter-Lorenz, P.A. and Gazzaniga, M.S. (1994). The disconnection syndrome: basic findings reaffirmed. *Brain*, 117, 105–15.

5

The frontal lobes: cognition, social behaviour and personality

- Frontal lobes: a brief review
- Frontal lobes: an anatomical sketch
- Early studies of frontal lobe function
- Tests used to measure frontal lobe (dys)function
- The symptoms: an introduction
 - Motor (precentral) symptoms
 - Sensory/perceptual symptoms
 - Cognitive (prefrontal) symptoms
- Do the frontal lobes mediate intelligence?
- Decision making
 - A note about the vagus nerve
- Reasoning
- Understanding what others do: theory of mind and the frontal lobe
 - Recent evidence for frontal cortex involvement
- Social behaviour and personality
- Theories of frontal lobe function
 - Luria's theory: the classical view
 - Norman and Shallice's supervisory attentional system
 - Rolls's theory of orbito-frontal function: stimulus-reward
 - Damasio's somatic marker hypothesis
- Summary
- Recommended further reading

Frontal lobes: a brief review

No two human brains are exactly alike in structure, yet all normal, healthy human brains share the same gross characteristics. The central sulcus, the lateral sulcus and other major sulci divide the hemispheres into occipital, parietal, temporal and frontal lobes. The conventional demarcation of the brain into four lobes is not based on actual functional or structural characteristics but on the brain's gross appearance, conveniently divided by the sulci, and the area of skull overlying them. Neurogeographically, the frontal lobes occupy the region found above the lateral sulcus and in front of the central sulcus, the parietal lobes occupy the region anterior to the central sulcus and inferior to the lateral fissure, the occipital lobes occupy the area at the back of the brain bordered by the parietal and temporal lobe, and the temporal lobes themselves occupy the area below the lateral sulcus, as Figure 5.1 shows.

Figure 5.1

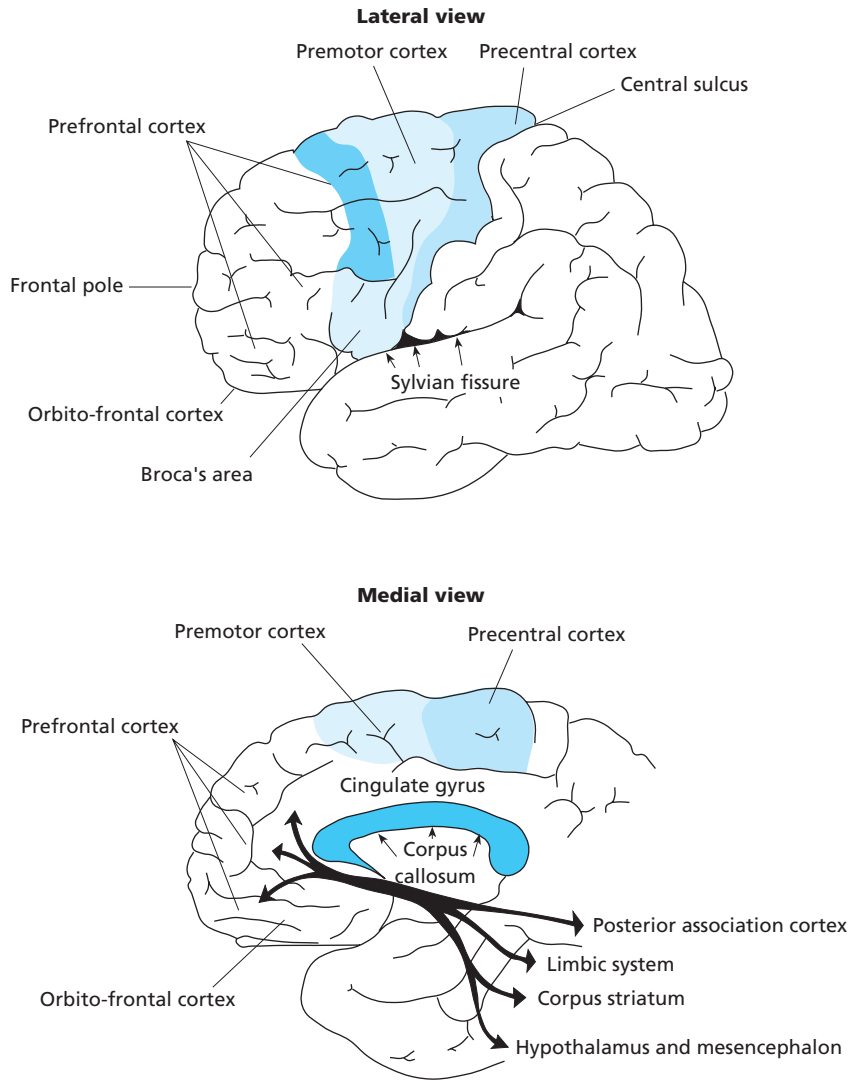
Geography of the frontal lobes (from Crawford *et al.* 1992)

Despite the arbitrary nomenclature, each lobe does appear to be responsible for some discrete aspects of behaviour. The occipital lobe contains area 17 (the primary visual cortex) and the association visual cortex. The temporal cortex contains the primary auditory cortex and association cortex. The parietal cortex contains the motor cortex (area 4) and areas concerning aspects of somatosensation, such as touch and temperature. The frontal lobes are psychologically more complex, however, in that they are the structures that (1) mediate the ability to engage in abstract thought, (2) allow planning and the organization of behaviour logically and temporally, and (3) inhibit inappropriate social and emotional responses, in addition to other functions. Some of the functions they are thought to mediate specifically are:

- working memory
- encoding and retrieval of information

- attention
- creativity
- dementia (fronto-temporal dementia; Pick's Complex, described in Chapter 11)
- intelligence
- reasoning
- emotional expression
- depressive illness
- Huntington's disease
- apraxia
- language (speech)
- theory of mind
- motor movement and preparation
- planning
- executive functions.

In summary, the frontal lobes have been regarded as the cortical locus of 'higher learning' and sometimes, rather mysteriously, as the structures that define the self (Goldstein 1936; Halstead 1947). The specific portion of the frontal lobes responsible for maintaining this cognitive behaviour is known as the prefrontal cortex. According to Luria (1973), the prefrontal cortex is essential for planning, making goals, and regulating and verifying behaviour – processes collectively known as executive functions:

- Divided attention
- Sustained attention
- Processing speed
- Initiation
- Sequencing
- Set-shifting
- Cognitive flexibility
- Planning

Frontal lobes: an anatomical sketch

The frontal lobes are the most recently developed of the four lobes and comprise about one-third of the cerebral cortex (Goldman-Rakic 1987). Brodmann (1909) identified thirteen anatomically distinct areas in this region, and several areas are anatomically and functionally distinguishable within it. They comprise the premotor area, including (area 6 and part of area 8), the prefrontal area (areas 9, 10, 45, 46) and the precentral area (areas 9, 10, 11, 12, 13, 24, 32), which contains the motor cortex. The frontal cortex includes the premotor region, which contains the supplementary motor area or MII, the frontal eye field (area 8), which controls aspects of eye movement, and Broca's area, which controls the production of voluntary speech. The anterior part of the frontal lobes is the prefrontal

region; this is thought to be involved in the maintenance and execution of abstract thought, reasoning and inhibition of responses. This is often subdivided into two regions: the orbito-frontal cortex (sometimes used synonymously with ventro-medial cortex), which corresponds to BA 11 and 47, and the dorso-lateral region, which corresponds to BA 45 and 46, and the posterior part of BA 9. The latter is thought to be the region specifically responsible for cognitive and executive functioning, working memory, conceptual reasoning and attention, whereas the former is thought to be the region involved in stimulus acquisition, association of stimuli with reward, behavioural self-regulation and complex decision making.

The complexity of the frontal lobes is such that they seem to impinge on the whole repertoire of behaviour – from motor movement and movement planning to social behaviour and personality. They are the brain's 'orchestra leader', directing the activity of other sensory, motor and cognitive systems and coordinating inputs to and outputs from all the major association sensory areas of the cortex as well as areas of the limbic system. This involvement of the frontal lobes in many aspects of behaviour is reflected in the region's massive connections with other brain areas. According to Luria (1973), 'the functional organization of the frontal lobes is one of the most complex problems in modern science'. The primary somatosensory cortex (SI), for example, sends projections to the primary motor area (MI), the supplementary motor area, certain gustatory regions near the frontal lobe and the somatosensory association cortex (SAI). In turn, SAI is connected to area 6 in the premotor cortex. Other association cortices such as SAII send projections to various parts of area 6 and the prefrontal cortex, whereas SAIII has connections to the dorsal and ventral prefrontal cortex and areas 23 and 24 (the cingulate gyrus).

Other sensory systems, especially the visual and auditory systems, do not connect directly with the frontal lobes but do so via association cortices or convergence zones where inputs from different sensory systems arrive. Further connections are found within the limbic system. These connections are reciprocal, in that the frontal lobes may project to these subcortical (and cortical) areas as well as receiving projections from them. Connections are not made in a general fashion, with all divisions of the frontal lobes connecting with these structures, but are made selectively. Thus the orbito-frontal region projects to the temporal pole and related structures more than it does to other regions.

Early studies of frontal lobe function

The first comprehensive – for its time – report of behaviour change following frontal lobe damage appeared 150 years ago (Harlow 1848, 1868). However, this account of a now famous case study, Phineas Gage (see later), did very little to stimulate immediate scientific interest in the frontal lobes as psychologically significant brain regions. Much later studies demonstrated that damage to the frontal cortex was associated with impaired cognitive and intellectual functioning. Rylander (1939), for example, reported that 21 out of 32 frontal lobe patients scored more poorly on tests of intellectual ability than did healthy controls. This impairment was not damage-general either. Patients with temporal, parietal and occipital lobe resection showed no difficulty with 'abstract thinking, the power of combination, and acts involving judgement' (Rylander 1943). Further

support for the role of the frontal lobes in intelligence came later with studies showing poorer ability to sort items according to a given rule in these patients than in non-frontal patients (Halstead 1940).

However, these early studies did not go unchallenged. Hebb (1939, 1941, 1945), for example, argued that there was no real significant difference between frontal and posterior damage patients on tests of intellectual ability (IQ tests). Although he did not argue that the frontal lobes had no part to play in intellectual behaviour, Hebb concluded that there was little evidence to suggest that these areas were more involved than others. One reason for the inconsistency may have been the small sample sizes and the likelihood that the intelligence tests used were not particularly sensitive measures. Current evidence from neuroimaging suggests that these regions are important for decision making and reasoning, and this evidence is reviewed in a later section.

Tests used to measure frontal lobe (dys)function

The problem of measurement is a recurrent one in frontal lobe and neuropsychological research. Tests of frontal lobe function normally, but not always, measure the ability of the patient (1) to sequence events logically and temporally, (2) to reason abstractly, and (3) to behave spontaneously. The most commonly used test in frontal cortex injury is verbal fluency, usually measured by the Controlled Oral Word Association test from the Multilingual Aphasia Examination (Benton and Hamsher 1978). This test requires the patient to name as many items as possible beginning with a given letter. Frontal lobe patients perform poorly, naming significantly fewer words than do controls and patients with brain lesions other than frontal.

The earliest tests of abstract reasoning were sorting tests involving cards printed with different designs (Goldstein and Scheerer 1941). In one of these tests, two packs of 64 cards featured designs that differed in shape, colour or number, and the patient was required to sort them according to some principle decided by the experimenter (Weigl 1941; Grant and Berg 1948). Without warning, the experimenter would then change the sorting principle, and the patient would have to shift his or her sorting strategy accordingly. The current version of the test is the Wisconsin Card Sorting Test (Milner 1964).

In Milner's (1963) version of the card-sorting task, four cards whose faces have one red triangle, two green stars, three yellow crosses and four blue circles, respectively, are placed before the patient. Patients are given 128 cards (comprising two sets of 64 cards) and are required to sort them according to a fixed criterion: colour, form or number. The examiner informs the subject whether a decision is right or wrong. Turning over a card with two yellow crosses could go with the two green stars (based on number) or three yellow crosses (based on colour) (see Figure 5.2). Therefore, more than one sorting must be undertaken in order to determine the correct strategy. If the examiner chooses colour and the patient makes ten consecutive correct responses, the criterion is, without the patient's knowledge, changed to number (or shape). Following ten consecutive correct answers, the criterion is changed again. Two measures of performance are (1) the number of categories obtained – four correct sorts by category indicates successful performance – and (2) the number of perseverative errors committed, i.e. the number of times that the patient responds using the criterion set in the previous sort.

Figure 5.2

A card-sorting task similar to the Wisconsin Card Sorting Task. The symbols on the cards can vary by type, number or colour

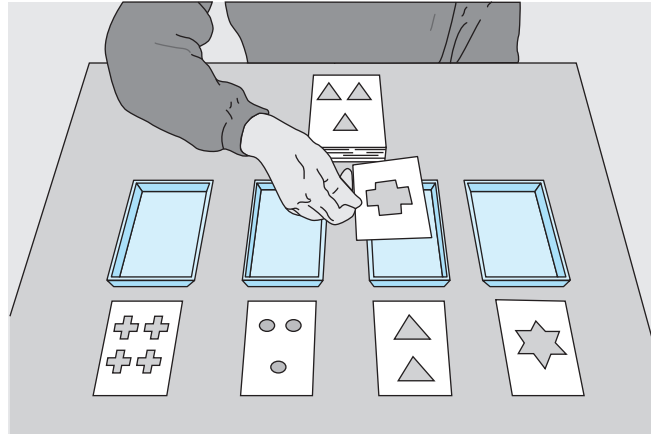

Some frontal lobe patients perform poorly on this task, making significantly more perseverative errors and failing to complete sorts. Similar sorting tasks in which some frontal lobe patients also have problems are ones that involve sorting six cards into two piles of three cards based on some feature of the design on the cards (Delis *et al.* 1992) or sorting blocks according to colour, shape, width or height (the Modified Vygotsky Concept Formation Test).

Another popular test is Shallice's (1982) Tower of London task, a variant of the Tower of Hanoi task. The Tower of London version requires participants to move coloured balls from an original position to a target position in a given number of moves. The outcome of the task is measured by the number of problems solved without error in 60 seconds. Examples of the Tower of London and the Tower of Hanoi tasks can be seen in Figure 5.3 (a) and (b).

Shallice has also devised two more 'realistic' tests of frontal lobe function in which the ability of the patient to undertake sequences of events in real life is measured. Shallice and Burgess's (1991) Six Elements Test, for example, requires the subject to undertake six open-ended tasks in a fixed time period, such as the following:

1. Dictate a brief account of the participant's journey to the testing place.
2. Dictate a brief account of the participant's intended journey from there.
3. Write the names of as many pictures as possible from one set of pictures.
4. Write the names of as many pictures as possible from another set of pictures.
5. Solve as many arithmetical problems as possible from one set of problems.
6. Solve as many arithmetical problems as possible from another set of problems.

The Multiple Errands Task involves the completion of a number of everyday errands such as shopping in an unfamiliar street according to a given but arbitrary set of rules. For example, the patient might have to buy specific items or send the experimenter a postcard on which he or she should have detailed four pieces of information, including the coldest

Figure 5.3

(a) The original Tower of Hanoi task. The participant's task is to recreate the arrangement of the discs in the model (top) from the starting position (bottom) in as few moves as possible and moving one disc at a time. A larger disc cannot be placed on a smaller one, and discs cannot be placed outside the posts (e.g. on the table) (from Bishop *et al.* 2001).

(b) The Tower of London task. The arrangement on the left is the starting point. The other three positions must be reached from this starting point. The second arrangement can be achieved in a minimum of two moves, the third in a minimum of four and the last one in a minimum of five (adapted from Shallice 1982)

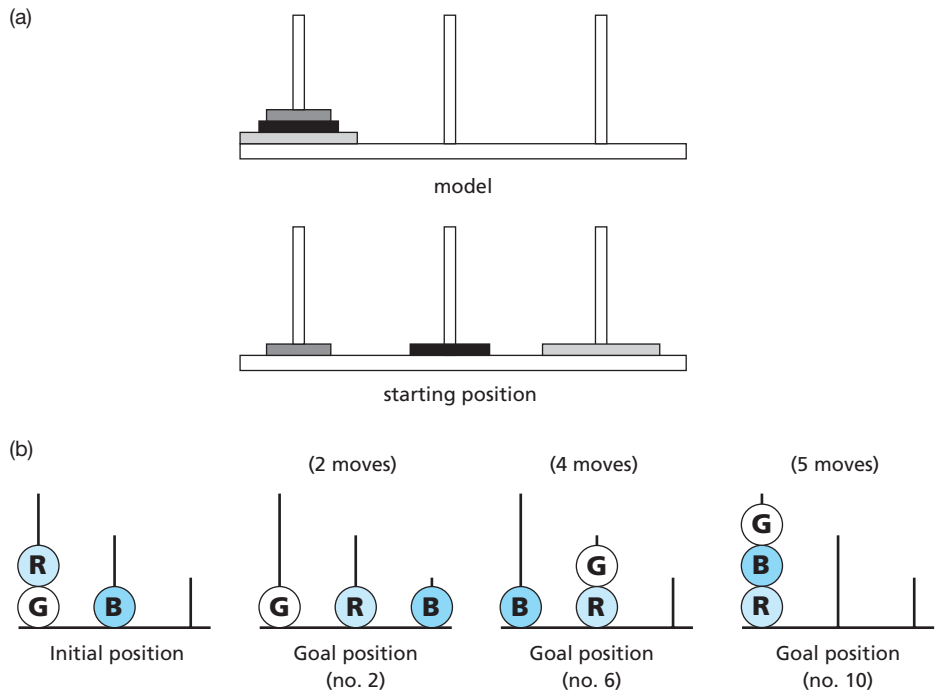

place in Britain on the previous day. Frontal lobe patients show impairments on both tests. More recently, a simplified version of the test (Alderman *et al.* 2002), as well as one more suitably adapted in a clinical setting (Knight *et al.* 2002) have been developed. For example, Knight *et al. (ibid.)*, used a hospital setting and hospital-related chores to assess organization and planning in brain-injured individuals. An example of this can be seen in Figure 5.4 (a) and (b).

Compared with a control group, the brain-injured sample were more impulsive, beginning their chores immediately without planning how to undertake them. The sample also appeared to 'know' what to do – its strategy to complete a task could be verbalized – but it did not carry this strategy through. The control group made use of the hospital map more often, used signs more frequently and was more competent at undertaking two or more errands concurrently. When the brain-injured sample did make use of signs, however, they made fewer errors. A review of the pros and cons of some commonly used 'frontal lobe' tests can be found in Table 5.1 (Crawford and Henry, in press).

Figure 5.4

(a) The plan of St Andrew's Hospital, Northampton, used in Knight *et al.*'s (2002) study. The numbers and letters refer to specific locations; (b) the participants' instruction sheet from the same study (from Knight *et al.* 2002)



(b)

INSTRUCTIONS

In this exercise you should complete the following three tasks:

1. You should do the following six things:

- Collect something for the examiner from Main Reception and do what is necessary
- Buy 4 1st class stamps
- Buy a get well card
- Buy a can of Coca-Cola
- Telephone Kemsley reception and say where you are, who you are, and what time it is
- Post something to Caroline Knight in Birmingham

2. You should obtain the following information and write it down in the spaces below:

1. What is the closing time of the staff library on a Friday?
2. What is the opening time of the hospital shop on a Saturday?
3. What is the price of a Mars Bar?
4. How many public car parks are there in the hospital grounds (not including staff or disabled only parking)?

3. You must meet me outside Main Reception 20 minutes after you have started the task and tell me the time.

Tell the person observing you when you have completed the exercise.

Whilst carrying out this exercise you must obey the following rules:

- You must carry out all these tasks but may do so in any order
- You should spend no more than £2.50
- You should stay within the limits of the hospital grounds
- You should not enter any of the hospital wards or 'staff only' areas
- No building should be entered other than to complete part of the task inside
- You should not go back into a building you have already been in
- You should buy no more than two items in the hospital shop
- Take as little time to complete this exercise without rushing excessively
- Do not speak to the person observing you *unless* this is part of the exercise

Table 5.1 Summary of some strengths and weaknesses of selected tests of executive dysfunction

Measure	Strengths	Weaknesses
Wisconsin Card Sorting	Extensive research base Good norms Moderate ecological validity Moderate sensitivity	Poor specificity Potentially confusing for clients
Verbal fluency	Extensive research base Good norms High reliability Quick and easy to administer and score Moderate sensitivity Normally distributed Moderate ecological validity	Low specificity Highly influenced by premorbid verbal IQ
Cognitive estimation	Derived from theory	Poor sensitivity Poor specificity Poor ecological validity Poor psychometric properties Poor norms
Brixton Spatial Anticipation Test	Derived from theory Moderate sensitivity Moderate specificity	Modest normative samples Coarse-grained scoring Limited research base as yet
Behavioural assessment of the dysexecutive syndrome	Derived from theory Very high ecological validity Moderate sensitivity (six elements)	Limited research base as yet Low sensitivity Specificity unknown
Dual-task methods	Derived from methods High ecological validity Good specificity	Not yet fully standardized and normed Potential problem with unreliability

The symptoms: an introduction

The neuropsychological consequences of frontal lobe injury have been characterized as a ‘syndrome’, i.e. brain injury is associated with a cluster of behavioural symptoms that reliably appear. However, there is considerable variation in the types of symptom seen in frontal lobe patients. Changes in social behaviour and personality can tend towards the depressive or manic end of the affective spectrum. Test performance between individuals with frontal damage can differ significantly, and the picture is further complicated by the specific region and hemisphere of the prefrontal cortex damaged. These findings cast doubt over the use of the blanket description ‘syndrome’ for the behavioural sequelae of frontal lobe damage. The sections below describe some of the symptoms that often, but

not always, accompany frontal lobe damage. These symptoms are classed as motor, where damage is to the precentral or motor strip, or cognitive, where damage is prefrontal. What is more, specific deficits can be localized to subdivisions of these regions: thus, personality changes and emotional disorders are associated with orbito-frontal lesions, whereas some cognitive and memory disorders are associated with dorso-lateral damage.

Motor (precentral) symptoms

One characteristic symptom of frontal cortex damage is impairment in organization and planning. This symptom involves not only abstract planning such as thinking ahead but also voluntary motor behaviour itself (Passingham 1995). For example, a patient may not be able to undertake a behaviour or response in a particular order (Luria 1966). Luria described this impairment as a disintegration in learned sequential actions in the sense that learned behaviour had become 'series of isolated fragments'. This impairment is evident even when copying simple gestures. Kolb and Milner (1981), for example, found that patients with left and right frontal lobe damage were poor at copying a series of facial (but not arm) movements, making more errors of sequence than did controls and other patients.

Removal of the supplementary motor cortex results in a brief impairment in all voluntary movements, with the only long-lasting impairment occurring in the patient's inability to make rapid alternating hand and finger movements. On the basis of blood flow and lesions studies, Roland *et al.* (1980) have suggested that the supplementary motor areas are 'programming areas for motor subroutes' where fast, independent movement is programmed.

Finally, one oculomotor deficit seen in frontal patients is impaired corollary discharge. This refers to the transmission of information from one brain region to the other so that the one informs the other of its intended action. If you push your eyeball, the world appears to move; when you move your eyes, the world stays still. There is a signal to indicate that the eyes are moving and that therefore the world is still; there is no signal when the eyeball is pushed mechanically. Thus voluntary actions require a corollary discharge from the frontal lobe to the parietal and temporal association cortex that primes the sensory system to anticipate movement. Frontal lobe patients seem to have an impaired corollary discharge (Teuber and Mishkin 1954).

Sensory/perceptual symptoms

Taste

The frontal (and temporal) lobe appears to have an important role in the perception of taste and smell and the mediation of food flavour (Martin 2004). When macaque monkeys are fed glucose, neurons in a region in the primary taste cortex, located in the frontal lobe, become highly responsive. Neurons in a nearby area – the secondary taste cortex – are also activated. However, when the monkey is fed the glucose to satiety, the responsiveness of the second area decreases. When the monkey is fed a food that it has not previously eaten (such as blackcurrant juice), neurons in this second area become responsive again. This increase and decrease in the activity of 'taste neurons' is also found whether the monkeys see the foods they have eaten to satiety or not (Critchley and Rolls 1996).

When we eat food to satiety, it still has a flavour but we find it less pleasant. There are only so many sausages we can eat in one session, but we will happily consider a bowl of ice cream after becoming satiated on ground pork. Current neuroimaging research suggests that the primary and secondary taste cortices are active when a person tastes a food (but does not eat to satiety). However, as satiety develops, activation in the primary taste

cortex remains fairly stable, but activation in the secondary taste cortex decreases. What this suggests is that one region in the brain responds to the sensory qualities of food (taste, texture, smell), but another, more sophisticated, area is responsible for our hedonic response to food.

The part that responds to the sensory properties of food – the primary taste cortex – occupies an area towards the back of the frontal lobe. The secondary taste cortex occupies a part of the orbito-frontal cortex (OFC). Damage to this region also leads patients to forget important steps when following recipes (Fortin *et al.* 2003). Satiety research has demonstrated that when water is ingested, the sensation of water in the mouth is initially associated with activity in the primary taste cortex and the OFC; this activity in the primary taste cortex remained stable even when the participants' thirst was slaked. When the water had been drunk to satiety, however, activation in the OFC decreased (De Araujo *et al.* 2003a). As the water became less and less pleasant, activation in the OFC decreased. The typical OFC decrease was found when chocolate or tomato was ingested to satiety (Kringelbach *et al.* 2003).

In a recent PET study, volunteers ate chocolate to satiety as the scanner measured brain activation (Small *et al.* 2001). Participants first ate a chunk of chocolate, rated it for pleasantness and were then asked if they would like another. If they did, they were given another piece and asked to rate its pleasantness. This continued until the participant indicated that he or she had eaten enough chocolate.

The researchers found that when participants ate chocolate they judged as pleasant, there was increased blood flow in a collection of brain regions, including areas beneath the corpus callosum (the band of fibres that connects the two sides or hemispheres of the brain), a part of the OFC (called the caudo-medial OFC), and three other regions. When participants were sated, blood flow increased in a different part of the OFC (the caudolateral OFC) and another region (one also involved in the ability to recall landmarks).

The researchers suggest that brain activation seen during ingestion of chocolate reflects two different systems, which in turn mediate two different aspects of behaviour: approach and withdrawal. When the brain responds to a reward positively, it activates the part of the OFC and another region implicated in reward and found in the frontal cortex (the insula). This reflects an 'approach' behaviour, because we tend to approach things we like and this generates a positive emotion. When the brain responds to non-reward or stimuli that do not provide an opportunity for reward (such as food we no longer want to eat), brain regions involved in 'withdrawal' are recruited. These are involved in withdrawal, because we tend to withdraw from stimuli we don't like and we find such stimuli unpleasant (or at the very least, do not find them pleasant).

Smell and the brain

Damage to the right temporal and orbito-frontal cortices results in impaired odour memory (Jones-Gotman and Zatorre 1993). Discriminating between odours becomes difficult when lesions are made to the same areas. If the frontal lobe is removed during surgery (to excise a tumour, for example), the ability to identify an odour will be relatively preserved if the OFC is spared but will be impaired if it is not.

In one of the first neuroimaging experiments of odour perception in humans, Yousem *et al.* (1997) exposed five men to the un-foodlike odours of eugenol, geraniol and methyl salicylate (what they referred to as olfactory odours) and ylang ylang, patchouli and rosemary oil (trigeminal odours). They found that the olfactory odours activated the right OFC, but the response decreased with repeated stimulation. Trigeminal stimulation and repeated testing with the olfactory odours activated different parts of the brain, including

the temporal lobe. The heterogeneity of brain response is common in studies of odour: smelling activates a range of brain regions, some more potently than others.

Levy *et al.* (1998) compared brain activation in eight patients with decreased sensitivity to smell (hyposmia) and seventeen healthy participants while they smelled pungent pyridine, l-menthone (peppermint) or amyl acetate (banana). Activation in healthy participants was found in the back of the OFC and the temporal lobe; similar activation was also seen in the hyposmic individuals but not as significantly as that seen in the healthy group. The greatest decrease was found in patients who detected but did not recognize the odours, and this was found in the frontal lobe. Studies using odours that are relevant to cuisine have focused on how the brain responds to pleasant and unpleasant smells.

In an experiment where researchers had participants smelling the odour of banana and peppermint or simply imagining these smells, both sides of the OFC and the temporal cortex were activated. However, activation during actual smelling was greater than that seen during imagination, which suggests that similar areas are used for both activities but that the degree of involvement is greater during actual perception. Studies of individuals who experience smell and taste phantoms show greater activation during actual smelling and tasting than when they experience their 'imaginary' smells and tastes. In a different study, left brain activation was greater than right when imagining and smelling the odours of peppermint and banana. A sex difference was found when participants smelled an unpleasant odour, however: right-sided activation was more common in men when they smelled pyridine. Greater activation has also been observed in younger participants' (24-year-olds) than older individuals' (73-year-olds) frontal lobe and related regions when these people smelled.

The link between the frontal lobe and pleasant odour perception is highlighted in another of Rolls's experiments (Rolls *et al.* 2003). His group presented men and women with a range of pleasant and unpleasant smells and recorded brain activation as these odours were smelled. Pleasant smells were associated with activation in a part of the OFC that is responsive in monkeys when they receive a reward for making an appropriate response. Different regions (the cingulate cortex) were activated by unpleasant and pleasant odours.

Flavour

What is intriguing is that the key area involved in smell and taste – the OFC – appears to contain neurons that are unimodal and multimodal. That is, they are responsive either to one type of sensory stimulation (smell or taste only, say) or to more than one (such as smell *and* taste or taste *and* vision). Extensive studies are rare, but one very provocative study found that in the OFC taste area, 34 percent of neurons were responsive to a stimulus's taste only, 13 percent were responsive to its smell and 21 percent to its appearance (Rolls and Baylis 1994). However, 13 percent also responded to smell and appearance, 13 percent to taste and smell and 5 percent to smell and appearance. All of these neurons were in close proximity.

This arrangement, although based on a study of a very small number of neurons, suggests that there are brain cells that appear to respond only to taste and smell (and these are important responses) and nearby cells that undertake an interactive, multi-sensory role. Significantly, there were fewer bimodal neurons (those that respond to smell and taste) in the primary taste cortex – the area that responds to the sensory aspects of food – than in the OFC. This finding, again, seems to highlight the importance of this region to a more sophisticated analysis of food perception. Perhaps this is the region where smell and taste sensations are combined to produce the effect we call flavour.

Cognitive (prefrontal) symptoms

The types of symptom seen in patients following prefrontal lobe damage can be grouped broadly along the following lines: impairments in spontaneous behaviour, planning and strategy formation, attention, utilization behaviour, memory and olfactory function.

Spontaneous behaviour

Some frontal lobe patients are characterized by lack of spontaneity in that they appear quite lethargic and speak very little, or they may perform badly on formal tests of verbal spontaneity, such as a verbal fluency task, or the alternative uses test in which patients generate as many uses for a common object as possible. On tests of spontaneity, different frontal regions appear to be required for different types of task. Patients with anterior brain damage, for example, perform significantly worse on this task than do patients with posterior lesions or undamaged control subjects (Eslinger and Grattan 1993). Patients with bilateral or left unilateral frontal impairment produce significantly fewer words on the word fluency test than do control subjects, whereas right frontal patients show no significant impairment (Janowsky *et al.* 1989). Eslinger and Grattan (1993) have described this impairment as a failure in ‘cognitive flexibility’. This impairment also has a non-verbal form. Patients with right frontal damage, for example, complete fewer drawings using four lines than do those with left frontal damage or control subjects (Jones-Gotman and Milner 1977).

The absence of ‘formal’ spontaneity is not always seen in frontal lobe patients, however. There are some patients with considerable frontal lobe damage who perform extremely well on verbal fluency tests and other ‘frontal lobe’ tests, which suggests caution in describing the symptom as characteristic of frontal lobe damage (Eslinger and Damasio 1985; Goldstein *et al.* 1993). In fact, ‘normal’ performance on these tests is not uncommon, yet the individual exhibits marked impairments in the planning and organization of his or her day. One well-known example of this is Eslinger and Damasio’s patient, EVR.

Disorganization in everyday life: the case of EVR

EVR was a well-liked and efficient accountant who, at the age of 35, developed a large orbito-frontal meningioma (a cerebral tumour). Although surgical removal of the tumour alleviated the symptoms of the trauma, EVR’s behaviour changed markedly for the worse. His progress has been extensively followed by Paul Eslinger and Antonio Damasio of the Department of Neurology, University of Iowa (Eslinger and Damasio 1985; Damasio *et al.* 1990), and his behaviour has been contrasted with that of other frontal lobe patients. The reason for the attention paid to EVR, and others like him, is that he performs well on standard neuropsychological and frontal tests, but his capacity for planning and organizing his own life and his conduct of relations with others are severely impaired. A brief bibliographical sketch will help to fill in the details.

EVR was the eldest of five children. He appeared to have had an unremarkable childhood: he was free of developmental illnesses and reached the normal developmental milestones. An excellent student with many friends, he married after college and worked to pay for his two years of training in accounting. At the age of 25, he had become the father of two children, was involved in church activities and was an accountant with a firm of home builders. By 29, he had been promoted to chief

accountant, and by 32 had become comptroller. He was regarded as a paragon: his sister looked on him as a role model and his brother described him as someone people looked up to. At 35, after experiencing the personality changes and impaired vision that accompany a tumour, he was diagnosed as having the orbito-frontal meningioma. This was removed, and he was discharged from hospital two weeks later. It is at this point that EVR's life began to change.

Three months after the operation, he became an accountant for a small home construction business. Against the advice of his friends and family, he invested all his savings in setting up a home-building partnership with a former co-worker described by Eslinger and Damasio as having a 'questionable reputation'. The business failed, and EVR became bankrupt. Following this incident, he attempted, and failed, to hold down a number of other jobs, including a warehouse labourer, a buildings manager and accountant for a car-spares company. He was described by his employers as tardy and disorganized, although his skills, manners and temperament were acceptable. His marriage broke up (after seventeen years) and, unable to keep a job or a family, EVR moved in with his parents.

Two years after the operation, EVR's difficulties continued. He worked for a while as a tax-returns officer, but his employment was terminated. He was fired from another job that he had to drive 100 miles to get to – he was fired for lack of punctuality. He remarried after his divorce, but this marriage ended after two years. He would take an inappropriately long time to make the simplest of decisions, take two hours to get ready for work and spend an inordinately long time shaving and grooming. He would spend hours deciding on a restaurant in which to dine, poring over the restaurant's seating arrangements, the menu plan and the atmosphere. He would drive to restaurants to see how busy they were but could not decide which one to choose. Even buying the most insignificant of items was tortuous: he would need to know the exact price of the item, a comparison of prices and the best method of purchase. He also began to hoard, refusing to part with dead houseplants, old telephone directories, six broken fans, three empty orange juice cartons and fifteen cigarette lighters among other detritus.

Two years and six years after the operation, his cognitive ability was evaluated on a range of tests. Two years after the injury, his verbal IQ was superior, his performance IQ average, his memory IQ above average and his personality showed no deviation from the norm. Six years after surgery, his IQ still placed him in the average to superior category.

At this point, he was referred to the neurology unit after a series of failed psychotherapeutic interventions. He was alert, cooperative, articulate and showed no impaired performance on frontal lobe tests. On the Wisconsin Card Sorting Test (WCST), he achieved criterion for six out of seven categories in seventy sorts. At the beginning of the fifth category, he remarked, 'Oh, it's designs now'. He was knowledgeable about national and international affairs and would answer rapidly and competently when given a social judgement task (solving moral dilemmas). He was described as showing a cynical attitude.

CAT and MRI slices of EVR's brain indicated that his entire orbital cortex on the right and part of the orbito-frontal cortex on the left had been removed by surgery. On the right, areas 11, 12 and 25 were damaged, and on the left, areas 11 and 12 were partially damaged, with area 25 remaining intact. Right mesial damage involved areas 32, 10, 8, 9, 24 and the posterior of area 6; left mesial damage involved areas 8 and 9. Lesions also affected areas 8, 9 and 46 of the right prefrontal cortex (the dorso-lateral

cortex), with the left remaining intact. White matter subjacent to the premotor area was also damaged in the right.

Perhaps the most remarkable aspect of EVR's behaviour, apart from the marked post-operative change, is the dissociation between average to superior performance on standardized tests and a failure to demonstrate the same efficient cognitive strategies in his own life. Eslinger and Damasio (1985) hypothesized that this dissociation could be for a number of reasons. It is possible that EVR was unable to analyse or integrate the premises of real-life problems. In standard tests, these premises are presented to the subject. Alternatively, EVR may have been unable to execute planned behaviour, despite having knowledge of the skills and principles necessary to do so and despite having the ability to analyse and integrate the premises of real life. Yet he could perform well on the WCST and did express and conceive appropriate plans, which he did carry out. Eslinger and Damasio suggest that the most likely explanation is that EVR had a defect of analysis and integration of real-life stimuli that may be attributable to an impairment in accessing previously learned strategies. This explanation is persuasive. Shallice and Burgess (1991), for example, have argued that the design of neuropsychological tests makes finding frontal-cognitive impairments especially difficult, because the patient is normally presented with a single, well-defined problem that has to be solved in a short period of time, often prompted by the examiner. This is very different from the planning and cognition necessary in day-to-day life. Tests devised to take in the multiple demands on the patient in everyday life show that frontal patients have extreme difficulty in performing these tasks (Shallice and Burgess 1991).

EVR continues to be monitored and assessed and provides modern neuropsychology with one of its classic case studies. Perhaps his greatest contributions to frontal lobe understanding are the realization that dissociations do exist between test and real-life performance, and that not all frontal patients are the same.

Planning/strategy formation

The card-sorting tasks described in the section on frontal lobe tests are tasks that involve the patient engaging in planning or forming strategies. Both Milner (1963) and Heaton (1981) found that fewer correct sorts were obtained by dorso-frontal than by non-frontal patients. In Milner's research, these patients also made more perseverative errors: dorso-lateral patients made 57, outpatients made eleven and the cortical non-frontals made sixteen, a pattern repeated in Heaton's data.

From these findings, Milner (1964) argued that 'the ability to shift from one mode of solution to another on a sorting task is more impaired by frontal than by posterior cerebral injury'. However, some evidence casts doubt on the usefulness of the Wisconsin Card Sorting Test (WCST) as a measure of frontal lobe function. In one study, no significant difference in severity of impairment was found between frontals and non-frontals on this task (Grafman *et al.* 1990). Similarly, no significant difference in the number of correct categories achieved or perseverative errors made was found in another study of forty-nine frontal patients and twenty-four non-frontal (temporal, parietal, occipital, thalamic, basal ganglia) patients (Anderson *et al.* 1991) – some patients even performed better than average on the test. However, a recent PET study in which the brain activation of normal, healthy volunteers was monitored while the subjects participated in a modified version of the WCST reported significant increases in activation in the left or bilateral dorso-lateral prefrontal cortex (Nagahama *et al.* 1996). However, this finding may be complicated by

the strictness of the statistical test used. For example, Van Horn and co-workers sought to investigate possible functional lateralization of frontal lobe task performance using PET in fourteen healthy volunteers (Van Horn *et al.* 1996). They found neither significant interaction between hemisphere and region nor any significant increase in activation in the prefrontal cortex during completion of the WCST, a delayed response alternation task and a spatial delayed task. With more liberal statistical comparisons, however, a significant increase in right superior frontal gyrus activation was observed during the WCST and the spatial delayed response task. Both studies highlight the importance of paying close attention to the ways in which data are analysed.

A shortened form of the WCST has also been developed (Nelson 1976) but appears to be performed no better by non-frontal than by frontal patients (Van den Broek *et al.* 1993). The WCST therefore appears to be an adequate test of general brain dysfunction, i.e. it can discriminate between patients with brain damage and those with no damage, but its usefulness as a specific test of frontal lobe dysfunction is questionable.

Although the WCST is thought to tap into the individual's ability to form strategies, there are other tests that tap similar qualities. Maze tests, such as the Porteus Maze Test, are thought to measure the individual's forward planning capacity. Porteus (1965) argued that planning was a prerequisite to every intelligent act and noted that lobotomized patients performed poorly on this maze test. Other studies had found that posterior and superior lesions produced more consistent deficits than did lesions at other sites (Lewis *et al.* 1956). Right frontal lobe damage, especially, is associated with poor performance on finger- and stylus-maze tests. If a subject enters a wrong alley on this test, a bell rings, which indicates that an error has been made. Controls commit about 100 of these errors, yet even when told of their errors, frontal lobe patients make the same errors again. Right but not left frontal lobe patients may make up to 350 errors with no further success.

Another spatial test with frontal lobe associations is Koh's Block Design Task, in which subjects are asked to recreate a design using patterned blocks. Frontal lobe patients may not correct their errors or may attend to only a small area of the design or may not be able to plan such a reconstruction. In a single photon emission computed tomography study, Rezaei and colleagues found significant blood flow increases in healthy subjects' frontal regions during performance of the WCST and the Continuous Performance Test (in which subjects are instructed to respond only when a blue M follows a red H), but not the Porteus Maze Test (Rezaei *et al.* 1993). The findings suggest that three out of the four standard frontal tests produced activation in the relevant brain regions, although such crude frontal measures cannot lead us to localize functions in these areas. This is an important study because, as the authors state, brain lesion studies 'only assess the absence of function, leaving the localization of the function as a matter of inference'.

Baker and colleagues have noted increases in rCBF in the bilateral prefrontal cortex, anterior cingulate gyrus, supplementary motor cortex and dorso-lateral prefrontal cortex during performance of the Tower of London task (Baker *et al.* 1996). There was also parietal activation and a decrease in activation at the bilateral superior temporal cortex, bilateral superior frontal cortex and bilateral sensorimotor cortex. In a comparison of hard and easy versions of the task, the authors found that the difficult version was associated with significant increases in the prefrontal and premotor areas. This study is interesting because the areas activated are also associated with activation during visuospatial working memory performance, and these perhaps reflect the executive, planning areas of the brain. This association between working memory and frontal lobe function is returned to later in the chapter.

Sequencing is perhaps the behaviour that may be most clearly affected in frontal lobe patients (Sirigu *et al.* 1995). Ultimately, sequencing – the organization of stimuli in the

correct, logical or learned order – is a function of rule learning. We learn to do things in a certain way in order to make them work, e.g. writing a letter on a computer entails enacting a sequence of behaviour such as plugging in the computer and switching on the hard disk and monitor, opening up the word-processing application, opening a folder and file and starting to write. Deficits of this kind were seen clearly in the behaviour of a 51-year-old man studied by Goldstein *et al.* (1993), who had suffered from a surgically removed frontal lobe tumour (see Figure 5.5).

Despite having been employed as a senior manager in an international company, two years after surgery the patient worked from home, was lethargic and had difficulty in making decisions. On one occasion, he took two weeks to decide which slides to show at a professional presentation. He never made the decision in the end. Yet his performance on a variety of frontal and neuropsychological tests was normal or above average. In order to determine the effect of the brain damage on the patient's everyday organizational behaviour, Goldstein *et al.* administered Shallice and Burgess's (1991) Six Elements Test and Multiple Errands Task. In comparison with Shallice and Burgess's control group, Goldstein *et al.*'s patient performed badly. For example, he would have to return to a shop to buy additional items; he would misinterpret instructions such as placing the stamp on the wrong card and would not complete tasks. He made these mistakes despite being able to explain his errors and recite the rules of the test. This disregard of instructions or task requirements despite having full knowledge and understanding of them has been termed goal neglect (Duncan 1995). In an explicit study of multitasking, Burgess *et al.* (2000), found that right prefrontal cortex lesions were associated with the planning component of the tasks, with damage to other regions affecting recall of task contingencies and rule breaking.

Figure 5.5

The MRI scan of Goldstein *et al.*'s patient. Note the large lesion in the left frontal cortex (MRI scans are read as mirror images – left is right, and right is left) (from Goldstein *et al.* 1993. Reproduced with permission from the BMJ Publishing Group)



In another experiment, Della Malva and colleagues required thirteen patients with anterior brain damage and thirteen patients with posterior brain damage to complete verbal and visual sequencing tasks (Della Malva *et al.* 1993). A series of cards featuring a single word or picture was presented to the patient. The patient's task was to arrange the cards to make a meaningful or logical sequence, but the stimuli also included 'capture' sequences. These sequences were two words or two pictures that went together logically but that had to be broken up in order for the sentence or visual sequence to make sense. Thus a verbal capture sequence would include 'of/full/the/was/coffee/cup'. The correct order, 'the cup was full of coffee', would entail breaking up the coffee/cup pair. Similar pairings were made for the visual stimuli. Della Malva *et al.* found that frontal patients had significantly greater difficulty in sequencing stimuli with capture sequences than did the posterior patients. Their patients were not less able than the posterior group to break the capture pair, but they made more errors in sequencing when capture sequences were present.

Such deficits can have serious consequences for everyday living. Patients have difficulty with what has been called prospective memory: remembering to perform an activity in the future (Maylor 1996). Prospective memory can be either 'time-based' or 'event-based'. In time-based experiments, the participant engages in a task and has to inform the experimenter when a certain time has elapsed (Einstein *et al.* 1998). This may be analogous to remembering to telephone someone in an hour's time (Maylor 1996). In event-based experiments, participants must make a response when a particular event occurs in a sequence of events. Fortin *et al.* (2003) examined the effect of confirmed or suspected frontal lobe damage on the execution of what they call daily living scripts: 'mental' schemata that outline the steps in a task, such as preparing a meal. Whereas there was no difference between the patient and control group when each had to prepare a menu, the frontal lobe group was significantly impaired at meal preparation and poor at grocery shopping. Common errors included an inability to use the correct quantity of ingredients and an inability to complete various courses – cakes were not baked, and the soup was cold. The patients also spent more time on shopping and meal preparation. Problems in everyday living are common in frontal lobe patients, as EVR's story testifies. Case study NM, described a little later in this chapter, also highlights these problems even when the injury occurred many years ago.

Attention

A number of the neuropsychological impairments that follow brain injury have been attributed to a failure in selective attention. Attention, as Chapter 4 showed, requires an individual to perceive and analyse data from one source of information while excluding other, irrelevant or interfering sources of information. Frontal lobe patients appear to have impaired attentional capacity in that they show poor concentration and are highly distractible (Mesulam 1986; Janowsky *et al.* 1989). However, this evidence is not consistent (Godefroy *et al.* 1994; Brazzelli *et al.* 1994).

Godefroy and Rousseaux (1996) measured the reaction times of eleven prefrontal patients in tasks requiring divided or focused attention and found that these patients showed significantly greater distraction to irrelevant items than did controls. Duncan (1995) has suggested that this attentional deficit in frontal lobe patients may be related to impaired general intelligence, a suggestion that is explored in the 'Do the frontal lobes mediate intelligence?' section.

Utilization behaviour

Utilization behaviour (UB) describes a behavioural disturbance in which the patient uses objects, prompted or unprompted, in his or her environment. Two types of UB have been

identified (Shallice *et al.* 1989). ‘Induced’ UB describes behaviour where the experimenter’s compoartment appears to prompt the use of objects (Lhermitte 1983), whereas incidental UB describes behaviour where the patient uses objects nearby when performing other tasks. According to Lhermitte *et al.* (1986), frontal lobe patients may also exhibit imitation behaviour (IB), i.e. they imitate the examiner’s gestures even though they are instructed not to. This behaviour precedes UB. In their study, UB and/or IB was present in 96 percent of 29 patients with frontal lobe lesions. The exact reasons for this are unknown. At the behaviour level, both types of patient are thought to be abnormally dependent on the environment. As Lhermitte *et al.* (*ibid.*) have argued, ‘the sight of the movement is perceived in the patient’s mind as an order to imitate; the sight of an object implies the order to use it’. At the cortical level, Lhermitte (1983) suggests that UB is the result of impaired inhibitory action of the frontal lobe on the parietal lobe. In normal individuals, the parietal lobe integrates sensory information from the environment, while the frontal lobe inhibits some of the parietal lobe’s activity. This relationship ensures the relative dependence on or independence from the external environment, making sure that the quality of external stimuli is examined. Frontal lobe patients are thought to have ‘released’ parietal lobe activity, which leaves the patient exposed to all external stimuli.

Memory

Memory is a concept so vague and broad that no behaviour can be said to be uninfluenced by it. It is essential for thinking, reasoning, even for ‘constructing’ oneself. A person with no memory of his or her past relinquishes the criteria that make him or her unique. We have seen that frontal lobe patients are sometimes poor at sequencing, ordering, planning and verbal fluency, all of which involve some memorial component. These patients also exhibit memory deficits on tasks of free recall, interference and working memory. Working memory describes the online supervision of information that has yet to be stored, and the concept is closely related to short-term memory (Baddeley 1986). More detail on working memory and the frontal lobes can be found in Chapter 9. Neuroimaging with healthy individuals has also highlighted the frontal cortex as being important for encoding and retrieval of material.

Encoding and retrieval

One of the important roles that the frontal lobes appear to undertake is the acquisition and retrieval of information. Some of the evidence derives from single-case studies (such as JB, described in the box below), but the majority of recent data have emerged from neuroimaging studies (Fletcher and Henson 2001). In these studies, the frontal lobes seem to be disproportionately activated by tasks that require encoding and retrieval and working memory – the ability to hold information in mind while undertaking a different task.

An fMRI study comparing individuals’ ability to hold verbal and non-verbal information in mind while engaged in another cognitive task found that different sides of the prefrontal cortex were activated (Walter *et al.* 2003). Previous neuroimaging research had suggested that the left prefrontal cortex was activated during object or verbal working memory (Smith and Jonides 1998), but others had suggested a dissociation only in the ventro-medial prefrontal cortex, with left activation being observed for verbal material and right for spatial material (D’Esposito *et al.* 1998). However, Walter *et al.* (2003) argue that these inconsistencies arise because the verbal and non-verbal materials used are not identical in the types of stimulus within each of the domains. Walter *et al.*, in two fMRI studies, presented physically identical stimuli to participants as part of a verbal and spatial working memory task. They found that the type of ‘domain’ (verbal versus spatial) did not result in exclusive activation of one side of the PFC – both domains did. However,

Figure 5.6

The different conditions (bound and separate) in Prabhakaran *et al.*'s (2000) study (from Prabhakaran *et al.* 2000)

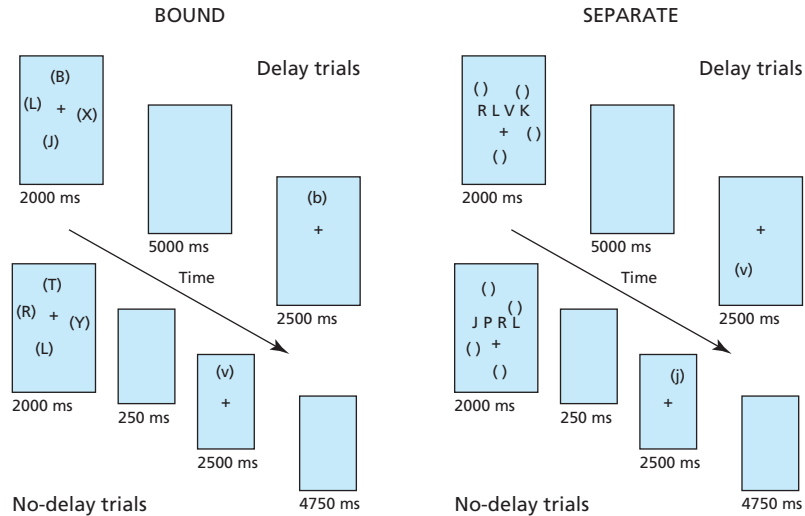

the type of material did activate more of one side than the other, with the left ventral areas showing greater activation during verbal working memory and the right showing greater activation for the spatial material (see Plate 5.1).

The frontal lobes also appear to show greater activation when they have to process 'integrated' information in working memory. For example, in one experiment, participants saw one of four letter or target locations: either four spatial locations, four letters, four letters to be remembered in the four locations (the integrated condition), or four letters presented centrally and separately from location (the unintegrated condition), as seen in Figure 5.6 (Prabhakaran *et al.* 2000). They were then presented with a letter and location and asked to judge whether the letter and location had been in the previous display. During fMRI scanning, activation was greater in the PFC when participants had to maintain the integrated stimuli than when they had to maintain in memory the unintegrated stimuli. More posterior regions showed the opposite pattern of activation. Similar levels of activation have been found in the frontopolar cortex when people complete an analogy task (Bunge *et al.* 2005). This group found that when thinking involved integration – the analogy task involved the presentation of two pairs of words and asking participants whether a subsequently presented pair of words was semantically analogous with it – greater activation was found in the left PFC. A semantic task in which the participants decided whether two words of a pair were semantically related activated the right dorso-lateral PFC, indicating a role for this region in response selection (rather than integration).

The role of the frontal lobes in encoding: the case of JB

JB had suffered an aneurysm that left his left ventro-medial frontal lobe and caudate nucleus damaged. He showed some of the typical frontal lobe symptoms: his performance on frontal lobe tests – those more sensitive to dorso-lateral damage – was good, but his behaviour was extremely disinhibited (Parkin 1997b). He would make highly

inappropriate comments to others – when JB was told that his neuropsychologist’s father had died, his response was one of indifference – and would talk to anyone, regardless of what they thought of him. He had been barred from all local pubs but could not understand why this was so. His planning was poor, his conversation was filled with cliché, and he could do little more cooking than boil an egg.

Cognitively, JB also showed evidence of frontal amnesia. He showed a specific deficit in encoding information (Parkin *et al.* 1999), with poor recognition memory performance. His hit rates were normal (when he said he recognized previously presented stimuli, he made few errors), but his false alarm rates were high (recognizing stimuli that had not been previously presented). These false alarms were reduced when JB was given specific instructions during encoding. His problem with encoding seemed to involve an inability to encode the specific, identifiable features of a stimulus: he would, instead, have some general idea of what the stimulus was and attempt recognition on that basis.

Figure 5.7

(a) The vocabulary knowledge of JB during the retrograde (left) and anterograde (right) periods; (b) JB’s cued autobiographical memory in the same period (from Ward 2003)

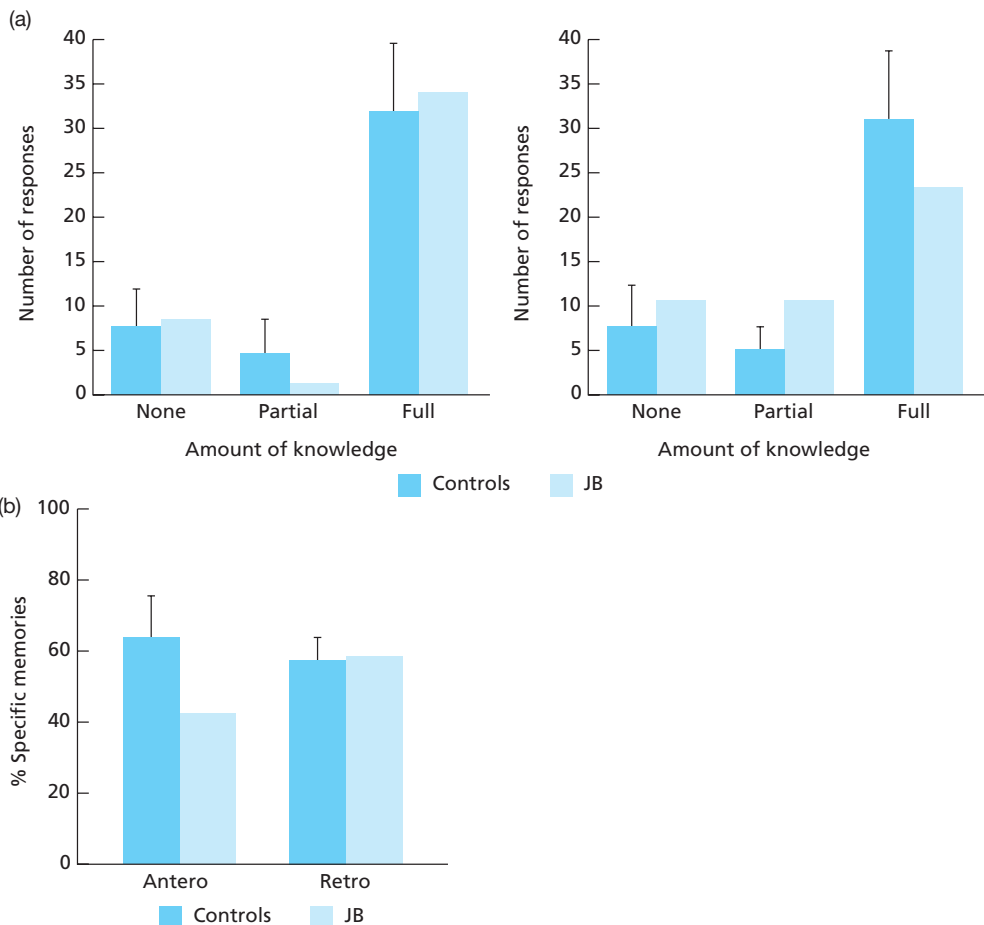

JB's memory impairment suggests the following hypothesis: his everyday memory problems should be anterograde, i.e. he would be worse at remembering material encoded after the aneurysm than before, because his problem specifically involves the encoding portion of memory (Ward 2003). The aneurysm occurred in 1984. This means that a roughly equal number of adult years straddles the time of the injury, so memory for events that occurred in each period can be compared and contrasted. Ward tested JB's memory for episodes occurring between 1960 and 1998. This included memory for famous faces, as well as vocabulary that emerged between 1960 and 1983 (e.g. 'Rubik's cube') and between 1984 and 1998 (e.g. 'Mexican wave', 'Viagra'). He was also presented with nouns and asked to generate memories to these words that occurred in each of the periods studied.

As Figures 5.7 (a) and (b) show, JB's performance was significantly worse when he had to recall events after his injury. His retrograde memory was unimpaired. The finding confirms the importance of the left ventro-medial frontal lobe in encoding new material.

Successful encoding and the prefrontal cortex

There is evidence that the prefrontal cortex is selectively activated by successful and/or deep encoding and unsuccessful and/or shallow encoding. Brewer *et al.* (1998), for example, found that greater right frontal cortex activity was associated with successful encoding in an fMRI study. Individuals were asked to view a series of indoor or outdoor scenes and decide whether each scene depicted outdoors or indoors. Thirty minutes later, they were given a recognition test and asked to indicate whether they remembered the scene, thought the scene was familiar but not well remembered or was forgotten. Memory for the scenes was predicted by frontal and parahippocampal activation, with greater activation found for the remembered images. Fletcher *et al.* (2003) explored whether the prefrontal cortex differentially responded during deep and shallow encoding in an event-related fMRI study. In the deep encoding condition, individuals made decisions about the pleasantness of various words; in the shallow condition, the individuals had to decide whether two underlined letters were in alphabetical order. When participants were engaged in deep encoding, activation was greater in the left prefrontal and left medial temporal lobes; when they were engaged in the shallow task, activation was greater in the right prefrontal cortex. When recognition memory was tested, those words that were deeply encoded were better recognized and this better recognition was correlated with left prefrontal cortex activation. Figure 5.8 illustrates this change.

Implicit and explicit memory

Another dissociation appears to arise when material is processed explicitly or implicitly. In explicit memory paradigms, participants are explicitly requested to recall material from a previous study session; in implicit memory paradigms, no such explicit instructions are given. The frontal lobe appears to be especially important for explicit memory. To determine whether different PFC regions are more or less involved in the two types of memory processing, Eskes *et al.* (2003) presented three memory tasks to patients with right dorso-lateral cortex damage, left dorso-lateral cortex and medial lesions under one of two instruction conditions: implicit and explicit. The tasks were word fragment completion, picture fragment completion and category exemplar generation.

Figure 5.8

Areas of activation in successful recognition memory using fMRI (from Fletcher *et al.* 2003)

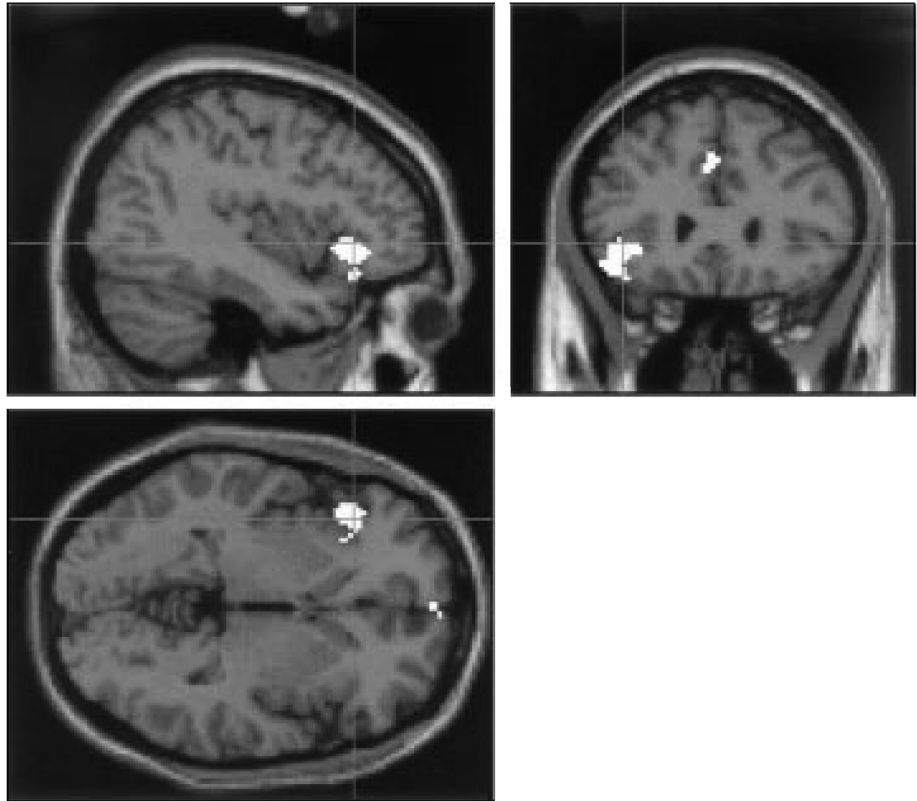

In the explicit version of the word fragment completion task, participants read aloud 45 nouns and rated how much they liked them. After a short delay, participants were presented with a series of word fragments and asked to complete the word using those they had read aloud (e.g. h__ e w __ k would be 'homework'). In the implicit condition, participants simply completed the fragment without being given the explicit instructions to remember the words they had read aloud. In the picture task, participants were asked to identify an object from a fragmented picture. In the explicit condition, participants were presented with pictures at an intermediate level of completion and asked to identify them with reference to the pictures they had previously seen. The implicit condition involved simply identifying the incomplete pictures. In the category exemplar task, participants read aloud words belonging to one of six categories (e.g. vehicles, countries). In the explicit condition, participants were given the previously seen categories and asked to name as many items from them as they could. In the implicit condition, participants were asked to generate eight exemplars from six categories with no instructions to refer to the previous categories.

Patients with left dorso-lateral damage were significantly impaired at the implicit version of the word fragment completion task; the left dorso-lateral group and those with medial damage were also impaired at the explicit versions of the category exemplar. The results provide some preliminary evidence that the left dorso-lateral cortex may be more involved than other regions in certain types of implicit memory processing.

Autobiographical/episodic memory

The ability to encode personally meaningful information – memory for personally meaningful events, people and objects – appears to recruit the prefrontal and medial-temporal cortex and the cerebellum (Cabeza and Nyberg 2000). Left-sided activation has been found during the encoding of verbal material, whereas the encoding of non-verbal material has been associated with bilateral activity in the frontal cortex. The role of the left prefrontal cortex in memory may be that of organizing information: this part of the brain is responsible for our ability to group items on the basis of some characteristic or attribute. Fletcher *et al.* (1998), for example, found that in a condition where a list of words was already organized, less left prefrontal cortex activation was found; when a task required the participant to generate an organizational structure, more activation was produced. Frontal lobe patients, however, especially those with damage to the frontal poles, have been found to be just as able as controls to retrieve semantic information, but they seem particularly impaired at retrieving episodic memories (Wheeler and Stuss 2003). They claim to know this information, but they are unable to remember it, suggesting to the authors that such patients have an ‘impoverished ability’ to recollect past autobiographical events consciously. Patients with damage to the dorso-lateral cortex do not appear to show this selective deficit.

The respective roles of the left and right sides of the prefrontal cortex in memory have been summarized by the HERA model, which proposes that greater left than right frontal cortex activation is seen during episodic encoding, whereas greater right than left frontal cortex activation is seen during episodic retrieval (Tulving *et al.* 1994). This model is described in more detail in Chapter 9.

Working memory

Baddeley (1986) has characterized frontal (specifically, prefrontal) dysfunction as a ‘dysexecutive’ syndrome involving the disruption of working memory. Working memory represents the mental process of ‘moment-to-moment awareness and instant retrieval of archived information’ (Goldman-Rakic 1992, 1996) and has been called ‘the blackboard of the mind’ because it allows the online supervision of information. The most important part of working memory is the central executive, which is thought to control resources and monitor information processing. It is served by two other processes, the phonological loop, which stores and rehearses verbal information, and the visuospatial sketchpad, which is concerned with visuospatial information and imagery. An example of the type of operation carried out by working memory is finding a number in the telephone directory and holding it in mental space until the number is dialled. Another is carrying over numbers in a mental arithmetic task: this involves storing one string of numbers while carrying out the next calculation.

Baddeley suggested that the impairments seen after frontal damage are malfunctions of the central executive. The central executive cannot be a unitary system, however, because performance on the Wisconsin Card Sorting Test correlates with tests of working memory, but performance on other tests of executive function does not (Lehto 1996).

A large part of the evidence for the role of the prefrontal cortex in working memory has come from primate studies in which monkeys perform a delayed-response task. These tasks require the retention of information for later use while simultaneously performing another mental operation. For example, in a fairly standard version of the task, a visual or auditory stimulus is presented to the monkey. After a delay of a few seconds, the animal is signalled to indicate where the stimulus had appeared. A correct answer is rewarded, usually with food or drink (Goldman-Rakic 1992). Neurons in the prefrontal cortex during the performance of this task appear to respond selectively to the period during the

delayed-response task. Some become active during the presentation of the information, others become active during the delay, while others become active when the animal makes a motor movement to indicate the location of the stimulus. Neurons capable of 'remembering' that a stimulus had appeared were organized in a specific region of the prefrontal cortex. It is thought that these represent the prefrontal cortex's spatial working memory system. Disruption of these neurons causes failure on the delayed-response task.

Based on this and related evidence, Goldman-Rakic (1992) has argued that the prefrontal cortex is divided into multiple memory domains, where each domain is responsible for a different aspect of memory: one is responsible for the location of objects, another for features of objects and others for semantic and mathematical knowledge. Furthermore, the prefrontal cortex, like other parts of the cortex, operates by inhibiting or exciting other parts of the cortex. These inhibitory or excitatory commands might be issued via neurotransmitters such as the catecholamines, especially dopamine (the prefrontal cortex is rich in these neurotransmitters). When levels of these chemicals are reduced, the types of working memory impairment seen on the delayed-response task in brain-damaged monkeys are apparent. Restoring the level of these chemicals restores performance.

A study of frontal lesion patients, temporal lesion patients and patients with amygdalo-hippocampectomy has found that while frontal lobe patients are poor at undertaking even the least challenging aspects of a spatial working memory task, other patients show difficulties only at the most challenging level (Owen *et al.* 1996). This finding is attributed to inefficient use of a particular searching strategy on the part of the frontal lobe patients. Two recent fMRI studies have also demonstrated the involvement of the prefrontal cortex in the maintenance of information that is characteristic of working memory (Cohen *et al.* 1997; Courtney *et al.* 1997). More on frontal contributions to working memory can be found in Chapter 9.

Do the frontal lobes mediate intelligence?

Since Hebb's (1939, 1941, 1945) devastating reviews of the role of the frontal lobes in intelligence – he concluded that there was not much of one – frontal lobe function and conventional intelligence have not been strongly associated. Warrington *et al.* (1986), for example, administered the Wechsler Adult Intelligence Scale (WAIS) battery to 656 patients with either unilateral parietal, temporal, occipital or frontal lobe damage and reported similar scores for each patient group. As we have seen in the preceding sections, some frontal lobe patients perform very well on standard 'intelligence' tests.

However, Duncan and his colleagues (Duncan, 1995; Duncan *et al.* 1995) propose that frontal lobe function is related to intelligence but not to conventional, general intelligence, or *g*. Instead, Duncan proposes that the frontal lobes might be involved in the execution of tests of fluid intelligence: that is, tests that do not require the subject to use prior information explicitly. (Those tests tapping *g*, such as tests measuring crystallized intelligence, do require such use, e.g. tests of vocabulary and general knowledge.) Duncan found that three of the frontal lobe patients he studied performed well on the WAIS but were poor on the Multiple Errands Task. However, on tests of fluid intelligence, such as Cattell's Culture-Fair Test, the patients' IQ scores were 22–28 points lower than their WAIS IQs.

Furthermore, their Culture–Fair IQs were 23–60 points lower than those of normal controls. This study suggests that when *g* is measured by tests of fluid intelligence, frontal lobe integrity is important for successful performance. If tests are tapping crystallized intelligence, the frontal lobes appear to be no more or less involved than other lobes.

An early PET study indicated that individuals with high IQs had lower metabolic rates than those with low IQ during problem solving (Haier *et al.* 1988). When high- and low-IQ individuals were trained on a computer game, both groups' brain activity declined, but the decline in the high-IQ group was more rapid, suggesting that the highly intellectually able may need to use less of their neural machinery to think (Haier *et al.* 1992).

However, the decline in activity seems to be general, although some studies show that regional activation is specific in high-IQ individuals but non-specific in individuals with low IQ (Neubauer *et al.* 1995). The less effort hypothesis also receives some support from EEG studies. High-IQ individuals show consistently higher EEG alpha power (that is, less mental effort) during problem solving and preparation for problem solving than do low-IQ individuals (Jausovec 1996). The most pronounced differences between high- and low-IQ individuals during working memory and arithmetic tasks was found across the frontal regions (Jausovec 1998).

Decision making

Antonio Damasio and colleagues' studies of patients with frontal lobe damage suggest that these individuals have great difficulty in making correct decisions (Damasio 1995; Bechara *et al.* 1996, 1997). Damasio suggests that the ability to make decisions leading to positive or potentially harmful consequences depends on the activation of somatic (that is, bodily) states. Damasio calls this the *somatic marker hypothesis*, because such decisions involve automatic, endocrine and musculo-skeletal routes (more on this later). These routes mark events as important but appear to be impaired in certain frontal lobe patients. For example, patients with damage to a specific area of the prefrontal cortex are unable to make decisions in real life despite having intact cognitive ability. When the decision can have a positive or negative outcome, the degree of physiological activity commonly seen in healthy individuals when they make such decisions is absent in these patients (Bechara *et al.* 1997).

In one study, frontal lobe patients and healthy controls were taught to play a card game, the Iowa Gambling Task, in which they were required to make as much money as possible (*ibid.*). There were four decks of cards, and some had a high probability of delivering a large immediate monetary reward or a large delayed monetary loss or a low immediate monetary reward or a low delayed monetary loss. No participant was told which deck contained the greatest probability of obtaining these outcomes, and they therefore had to learn from experience, turning over cards and remembering the outcomes. They had hunches. For example, when a decision involved a high degree of risk (such as losing a large amount of money), a healthy individual would show a characteristic increase in physiological arousal but the frontal lobe patients would not. The patients would show a characteristic response after they had lost or gained, as would controls, and all patients were aware that they had lost money. In imaging studies, performance on the gambling task is associated with increases in blood flow to the ventro-medial region of the frontal cortex (Elliott *et al.* 1997; Grant *et al.* 2000).

Bechara *et al.* (2000) were interested in determining whether these patients behaved in the way that they did because they were hypersensitive to reward, were insensitive to punishment or were insensitive to future consequences. In a modified task, advantageous decks of cards yielded high immediate punishment but even higher future reward. Disadvantageous decks yielded low immediate punishment but even lower future reward. Skin conductance response was measured after the participant had received reward or punishment. The group found that the VM patients opted for the disadvantageous decks and failed to be sensitive to future consequences. Instead, they seemed to be guided by immediate reward. The researchers call this 'myopia for the future'. Even when the future consequences of behaving in a particular way are undesirable, these patients continue to behave in an inappropriate way. The group followed this up with a study showing that people suffering from substance abuse disorder showed an impairment in decision making on the Iowa Gambling Task (Bechara *et al.* 2001). The majority of the substance abusers performed within the same range as people with damage to the ventro-medial cortex.

However, research suggests that the role of the prefrontal cortex in this aspect of reward and risk taking may be overstated. Manes *et al.* (2002) argue that although studies have ostensibly shown deficits in the gambling task in patients with frontal lobe damage, this damage is not restricted to the frontal cortex but extends beyond it. In Bechara *et al.*'s (1996, 1997) studies, for example, lesions were found in the medial orbito-frontal region but extended to the dorso-lateral cortex and other neighbouring regions. Manes *et al.* (2002) studied the effects of restricted orbito-frontal cortex, dorso-lateral, dorso-medial and large frontal lesions on a variety of neuropsychological measures, including the Iowa Gambling Task and a version of this designed to increase the sense of risk.

They found that dorso-lateral lesions were associated with working memory, set shifting and Iowa Gambling Task impairments; dorso-medial lesions were associated with planning and Iowa Gambling Task impairments; and orbito-frontal lesions were associated with performance at control level, but patients showed prolonged deliberation on the Tower of London task, a task that required forward planning. However, the group with large frontal lesions showed great impairment and was the only group to show risky decision making. According to Manes *et al.*'s criteria, patients in the Bechara studies would be classified as having large frontal lesions. Fellows and Farah (2005) have also reported that ventro-medial and dorso-lateral cortex damage can cause impairment on the Iowa Gambling Task.

These results suggest that the size of the lesion may be the critical predictor of risky decision making: both the dorsal and ventral parts of the prefrontal cortex need to be damaged before impairments are observed. Four out of five patients with large frontal cortex damage had lesions to the right side, perhaps indicating that the impairment can be lateralized.

A note about the vagus nerve

One neuroanatomical factor that could influence decision making is, surprisingly, one of the cranial nerves. The somatic marker hypothesis argues that there are three ways in which the body's somatic sensations can be relayed to the brain and the body and consequently affect cognition: the spinal cord, the endocrine system and the vagus nerve.

Stimulation of the vagus nerve has been associated with improved memory performance (Clark *et al.* 1999). When the left vagus nerve was stimulated (as part of epilepsy treatment), a PET study showed an increase in the thalamus, hypothalamus and orbito-frontal cortex (Henry *et al.* 1998).

The vagus nerves are large and are principally sensory in function. The left vagus nerve receives projections from the stomach; the right from the atria of the heart, liver and duodenum. Parts receive visceral sensations; others gustatory. If the vagus nerve, and its role in sensation, is important for the generation of emotion during decision making, Martin *et al.* (2004) hypothesized that stimulation of the nerve might influence decision making. They tested this in eight epileptic patients with implants that delivered vagus nerve stimulation and found that decision making improved when stimulation occurred.

The question of whether the vagus nerve influences decision making by altering the way in which the brain perceives somatic states or by transiently improving memory is one that is still unanswered. It has also been reported that vagus nerve stimulation can moderately improve depression (Marnegell *et al.* 2002). This suggests another mechanism by which the vagus nerve may affect decision making: by improving mood.

Reasoning

If the frontal lobes are important for reasoning, then we could predict activation in these areas when healthy individuals perform a reasoning task during neuroimaging. Goel *et al.* (1997, 1998) reported two experiments in which they sought to test this hypothesis. In one experiment, they asked ten participants to undertake inductive and deductive reasoning tasks. These involved syllogistic reasoning tasks such as deciding whether the following logic was correct:

All carpenters are young.

All woodworkers are carpenters.

All woodworkers are young.

and

George was a woolly mammoth.

George ate pine cones.

All woolly mammoths ate pine cones.

The experimenters found that the frontal lobes were involved: significant increases in activation were reported in the left inferior and middle frontal gyri. But reasoning appears to be dissociable in that the type of content in a reasoning task affects how well people reason. When given a task where the content is familiar (e.g. all apples are red fruit; all red fruit are sweet; therefore, all apples are sweet), people perform such syllogisms better than if the content is not familiar and more formal (e.g. all A are B; all B are C; therefore, all A are C). The former example seems to be associated with increased left frontal activity, whereas the latter is associated with increased bilateral parietal activity with some evidence of prefrontal activation.

Based on this evidence, Goel *et al.* (2004) reasoned that focal lesions in the left frontal cortex would have a more detrimental effect on a reasoning task that involved familiar content than one where the content was more formal. They administered three versions of a syllogistic reasoning task to patients with frontal lobe lesions and age- and education-matched controls. One task involved an arbitrary rule condition, a second an abstract rule condition and a third a condition that involved a rule that was personally meaningful. Both groups of participants performed similarly on the arbitrary rule condition task, but

controls were significantly better at the task where the content was personally meaningful. As predicted, those with left hemisphere lesions performed worse at this task than did those with right frontal lesions.

The study clarifies the role of the frontal lobes in specific types of reasoning: they appear to be more involved in reasoning that requires people to understand socially pertinent information. In doing so, the left frontal lobe appears to be more involved than the right.

As inductive and deductive reasoning are distinct psychological processes, we might expect different regions of the brain to be recruited when people perform the two types of reasoning task. One fMRI study found that both tasks activated the left prefrontal area but also bilateral regions of the frontal, parietal and occipital cortices (Goel and Dolan 2004). There was some evidence of a dissociation, however. The deductive task was associated with greater activity in a region called the left inferior frontal gyrus (area 44 – Broca's area), whereas the inductive task was associated with more activity in the left dorso-lateral prefrontal gyrus (area 8/9). Broca's area, in addition to its traditional function, is also involved in working memory and in processing syntax – two activities involved in deduction. Inductive reasoning relies on less logical forms of thinking and relies on the person's background knowledge. The authors point to studies showing how dorso-lateral lesions in patients result in deficits in everyday reasoning, reasoning that is similar to that involved in inductive tasks.

Discussion point: the role of neurochemistry in frontal lobe dysfunction

A chemical explanation for some reasoning difficulties in frontal lobe patients is a lack or loss of acetylcholine. Saykin *et al.* (2004) administered a cholinergic drug to a group of individuals with mild cognitive impairment, who completed a range of cognitive tasks including working memory, verbal learning, and memory and executive functions. Their responses were compared with a group of matched controls. fMRI scans of participants were taken.

At baseline, individuals with mild cognitive impairment showed significantly less frontal and parietal lobe activation during the working memory task compared with the brains of controls. After a short period on the drug, however, participants showed an increase in frontal lobe activity compared with unmedicated controls. This increased activity correlated positively with improved task performance and also with the size of the hippocampus at baseline. The researchers suggest that a short-term course of an acetylcholine-enhancing drug can result in increased frontal lobe function. This increase is related to improved cognitive function and to the integrity of the hippocampus.

Understanding what others do: theory of mind and the frontal lobe

Theory of mind (ToM) refers to a person's ability to infer the intentions and mental states of others (Leslie 1987). Most experimental attention has focused on the emergence of this skill in children (and in autism, in particular) because it is considered to be one of the

milestones of cognitive development. A commonly used test of theory of mind is the false-belief task. In a typical version of the false-belief task, person A places an object in a cupboard and leaves the room; person B enters, puts the object in a different location and leaves the room; person A re-enters, and the participant is asked where person A will look for the object. Children have been found to improve on false-belief tasks from around 3 to 5 years of age (Wellman *et al.* 2001), and performance is not culture-specific – European, North American, East Asian, Australian and African children have all been found to acquire understanding of others' beliefs at around the same time (Wellman *et al.* 2001). There is some evidence to implicate the frontal cortex, and other regions, explicitly in ToM task execution (see below). There is also evidence to suggest a role for this region in autism, a developmental disorder that has three defining characteristics – social abnormality, language abnormality, and stereotypical and repetitive patterns of behaviour (Frith 1989) – but this evidence is patchy at best.

Happe and her colleagues (Happe 1999; Happe *et al.* 1999) have suggested that individuals with damage to the right hemisphere will show impaired ToM but good reasoning, because damage to the right hemisphere causes impairments in social behaviour and thinking similar to those seen in children with impaired theory of mind (Happe *et al.* 1999).

Using the understanding of stories and cartoons as a measure of ToM, Happe *et al.* investigated the performance of patients with right hemisphere lesions and a group of healthy controls. The right hemisphere patients were significantly worse at understanding material that required the attribution of mental states (but not material that was non-mental in nature). A group of patients with left hemisphere damage performed no worse on the mental than on the non-mental material.

The researchers do point out that the study has limitations. The exact location of the lesions in all patients was unknown, so localizing ToM ability to any region more specific than the right hemisphere was impossible to do in this study. Because the left hemisphere group had language difficulties, the ToM tests were modified to take this language impairment into account, which may be another confounder. A group of language-intact left hemisphere patients might have been a better comparison group, but such a group would be difficult to find. The researchers suggest that a further study with patients having precisely delineated lesions would help to pinpoint which region of the right hemisphere is more involved in ToM task performance.

A resting EEG study of social behaviour in high-functioning autistic children found that children who were socially impaired showed greater resting right frontal asymmetry, whereas the children who had fewer symptoms of social impairment – but did report social anxiety, distress and less satisfaction with interpersonal relations – showed greater left frontal asymmetry (Sutton *et al.* 2005). This, as is considered more in the chapter on emotion, suggests that the frontal cortices may play differential roles in positive and negative emotion. It is also a more recent addition to the studies implicating the frontal cortex in autism, social functioning and ToM.

Recent evidence for frontal cortex involvement

A Japanese study of regional cerebral blood flow in a group of twenty-three children with infantile autism and a group of IQ- and age-matched children found a reduction in blood flow in the left prefrontal cortex, the superior temporal lobe and the angular gyrus areas of the autistic sample (Ohnishi *et al.* 2000). The authors suggest that these regions, which are known to be responsible for aspects of the integration of sensory information, are impaired in autistic individuals.

The idea that the frontal cortex is involved in ToM was supported in a study in which patients with frontal lobe damage were compared directly with patients with other types of brain injury. Frontal lobe patients were poorer than patients with damage to other brain areas when making inferences about other people's points of view (Stuss *et al.* 2001). This study also found that frontal lobe patients were poorer than others at detecting deception (i.e. uncovering people's real motives).

The finding is echoed in a study by Rowe *et al.* (2001), which asked thirty-one patients with unilateral frontal lobe lesions and a control group to read a story in which the reader has to make inferences about the behaviour of the protagonist. For example, in one story, a man and a woman are doing housework. The woman asks the man to put washing from the linen basket into the washing machine and put powder in the powder tray. She tells him not to turn the machine on. The woman vacuums upstairs and changes the bed. She puts the bedclothes in the machine and puts washing powder in a ball-shaped container and sets the machine going. The machine oozes with soapsuds. The participants are asked why the woman is surprised to see the soapsuds (the woman had acted on the false belief that the machine did not contain washing powder). The task is designed to assess participants' ability to infer false beliefs. Individuals with left and right frontal cortex injury were impaired at answering this question and at answering questions on other false-belief tests.

How we feel emotionally about others can differ quite markedly from how we think other people feel about the same circumstances or individuals. Perspective taking is an important human skill because it helps us to understand, and to empathize with, others. A new study has shown that taking a different view of the same person recruits different brain regions (Ruby and Decety 2004). The researchers asked participants to either adopt their own viewpoint or that of their mother when answering either a neutral or emotional question. PET was used to measure brain activation.

They found that blood flow differed between the first- and third-person perspective taking. When participants responded as themselves, the somatosensory cortex was activated; when they imagined how their mothers would respond, a series of blood flow changes in the frontal and parietal regions was found. Furthermore, the left temporal region was activated when the person responded in the third person to the emotional question, whereas the somatosensory cortex was activated when the person replied as themselves in the same condition.

The neuroimaging research on ToM suggests that the frontal lobe is involved in the ability to ascribe motives and beliefs to others. However, not all studies support this link between ToM performance and frontal cortex involvement, as the box shows.

Are the frontal lobes necessary for theory of mind? The case of GT

A prominent explanation of 'theory of mind' suggests that the medial frontal lobe plays an essential role in allowing people to mentalize in the way that theory of mind requires (Gallagher and Frith 2003). However, a new single-case study challenges this view.

Bird *et al.* (2004) studied patient GT, who had suffered brain damage as a result of stroke. There was extensive bilateral damage to the medial frontal lobes exclusively. GT showed the typical frontal lobe symptoms – impairments in planning and memory. However, there was no evidence of impairment on theory of mind tasks, suggesting that the medial frontal lobe may not be necessary for performing such tasks. Why,

then, does neuroimaging evidence and some clinical neuropsychological evidence suggest otherwise? Bird *et al.* suggest that this could be because the medial frontal lobes are necessary for the acquisition of theory of mind but not for implementing theory of mind functions.

Social behaviour and personality

In the report of their patient PG, Brazzelli *et al.* (1994) suggest that ‘one of the possible consequences of severe “frontal” derangement is social inadequacy’ (p.45). One of the most striking cases of frontal lobe damage associated with emotional and personality disturbance was reported by Harlow in 1848. This is the case of Phineas Gage, whose accident has been excellently summarized by Damasio *et al.* (1994):

On 13 September 1848, Phineas P. Gage, a 25-year-old construction foreman for the Rutland and Burlington Railroad in New England, became a victim of a bizarre accident. In order to lay new rail tracks across Vermont, it was necessary to level the uneven terrain by controlled blasting. Among other tasks, Gage was in charge of the detonations, which involved drilling holes in the stone, partially filling the holes with explosive powder, covering the powder with sand, and using a fuse and a tamping iron to trigger an explosion into the rock. On the fateful day, a momentary distraction let Gage begin tamping directly over the powder before his assistant had a chance to cover it with sand. The result was a powerful explosion away from the rock and toward Gage. The fine-pointed, 3-cm thick, 109-cm-long tamping iron was hurled, rocket-like, through his face, skull, brain, and then into the sky. Gage was momentarily stunned but regained full consciousness immediately thereafter. He was able to talk and even walk with the help of his men. The iron landed many yards away.
(p. 1102)

When John Harlow, the physician who treated Gage and wrote up the case study, arrived at the scene of the incident, he observed that Gage ‘bore his sufferings with the most heroic firmness’ and wrote:

From their appearance, the fragments of bone being uplifted and the brain protruding, it was evident that the fracture was occasioned by some force acting from below upward. . . I passed an index finger in its [the scalp’s] whole length, without the least resistance, in the direction of the wound in the cheek, which received the other finger in like manner. [The tamping iron had cracked the floor of the orbit of the left eye] entered the cranium, passing through the anterior left lobe of the cerebrum, and made its exit in the median line, lacerating the longitudinal fissures, fracturing the parietal and frontal bones extensively, breaking up considerable portions of the brain, and protruding the globe of the left eye from its socket, by nearly one half of its diameter.
(Harlow 1848: pp. 20, 21)

Gage made a good physical recovery – largely because his injury was cauterized – and many of his cognitive abilities remained intact. However, during and after convalescence, his personality appeared to change. He became profane, irreverent, capricious, lost all sense of responsibility, lost his job and thought nothing of contravening social niceties. His

acquaintances remarked that he was ‘no longer Gage’. As Harlow (1868) observed, ‘the equilibrium between his intellectual faculty and animal propensities had disappeared’.

Gage died in 1861 in San Francisco. Little neuropsychological interest was prompted by Harlow’s report, perhaps surprising given the implicit observation that damaged frontal cortex was associated with impaired planning and execution of social behaviour (Damasio *et al.* 1994). Harlow (1848) himself remarked that ‘the injury has been seriously questioned by many medical men for whom I entertain a very high respect’. As there was no autopsy, no clear description of the lesion could be obtained *post mortem*. Harlow did retrieve Gage’s skull, however, and both this and the tamping iron now belong to the Warren Anatomical Medical Museum at Harvard University.

Based on the dimensions of the skull, Damasio *et al.* (1994) remarkably plotted the trajectory of the tamping iron to ascertain the precise anatomical path of the object, as seen in Figure 5.9 and Plate 5.2. They concluded that the tamping iron must have produced lesions in the anterior half of the left orbito-frontal cortex (areas 11 and 12), the left polar and anterior mesial frontal cortex (areas 8, 9, 10 and 32) and the most anterior part of the anterior cingulate gyrus (area 24). The supplementary motor area was apparently spared, as was the frontal operculum (which contains Broca’s area). There were lesions to the right anterior and mesial orbital region (area 12), the right mesial and polar frontal cortices (areas 8, 9, 10 and 32), and the right anterior part of the anterior cingulate gyrus (area 24). The supplementary motor cortex was also spared on the right. No damage occurred outside the frontal lobes.

Figure 5.9

Phineas Gage’s skull (reprinted with permission from *The return of Phineas Gage: clues about the brain from the skull of a famous patient*, *Science*, Vol. 264, pp. 1102–5, Figure 1, Damasio *et al.* © 1994 AAAS)



Damasio and his colleagues' reconstruction of the iron's trajectory gives a more precise picture of the brain structures damaged after the accident. These structures are part of what is known as the ventro-medial or orbito-frontal cortex.

Since Harlow's report, a number of studies of frontal cortex damage suggest that damage to various parts of the cortex produce disturbances in personality (Stuss and Benson 1986). Damasio's group has also reported that EVR/Phineas Gage-type symptoms may depend on which side of the frontal lobes is damaged. Tranel *et al.* (2002) examined patients with unilateral left or right frontal cortex damage for social conduct, decision making, personality and emotional processing difficulties. They found that patients with right-sided damage showed the most profound impairment in performance on these measures; those with left-sided damage showed little impairment on these tasks. These findings, the authors suggest, 'provide preliminary evidence that the right and left sectors play asymmetric roles, at least as far as domains such as social conduct, decision-making, and emotional processing are concerned'.

The following personality changes have been found to accompany frontal cortex damage (Stuss *et al.* 1992):

- exhilaration
- childish behaviour
- lack of restraint
- depression
- anxiety
- restlessness
- decreased concern with propriety
- social withdrawal
- purposelessness
- irritability
- slowness in thinking
- apathy and indifference
- inertia
- decreased self-concern
- lack of judgement
- lack of ambition
- impulsiveness
- lack of reliability
- indifference to the opinions of others
- distractibility
- facetiousness
- egocentricity.

The first observation one can make of the list is that these features could characterize many friends and colleagues, yet it is unlikely that they are suffering from lesions to the frontal cortex. The second is that the list appears to represent a dichotomy in that some symptoms are clearly 'active', whereas others are 'inactive'. There is also the problem of possible involvement of subcortical structures and subcortical damage. As Stuss *et al.*

(*ibid.*) conclude: ‘disturbances in drive, mood and affect probably involve pathology beyond the strict confines of the frontal lobes’. Some of the specific evidence implicating the orbito-frontal cortex and other brain regions and systems in personality is reviewed in the discussion point below.

Discussion point: where are the neural correlates of personality?

The personality changes that follow orbito-frontal cortex injury tend not to be systematically examined. The researcher, clinician, family member of the patient him or herself may remark that the patient has changed in some important way, but rarely is personality as a construct investigated. This would be useful, because it might suggest potential neural correlates for personality types.

However, a study from the University of Oxford has shown that patients with damage to this specific region show a different pattern of behavioural impairment than do those with damage to other areas of the prefrontal cortex (Berlin *et al.* 2004). It found that patients with damage to the OFC were more impulsive and reported engaging in more inappropriate behaviour than did patients with non-OFC damage. These patients also reported more subjective anger than did other patients and controls, and less happiness than the control group. There were no significant differences between the groups on a standard measure of personality (the big five), however.

Studies of healthy individuals have provided more specific but complex data about the interaction between personality types and neural behaviour. Canli *et al.* (2001) predicted that extroversion would be correlated with greater brain activation when people watch pleasant images, whereas neuroticism would be correlated with greater brain activation when participants watch unpleasant images. Their rationale was based on the assumption that extroverts would be more positively disposed and would respond enthusiastically to pleasant stimuli, whereas neurotic participants would react intensely to negative stimuli. Their predicted result was found in an fMRI study of fourteen women.

A typical finding in the emotion literature is that the amygdala is more greatly activated when participants view fearful faces and fearful faces of increasing intensity. Canli *et al.* (2002), however, although finding this general effect in an fMRI study, also found that personality type – specifically, extroversion – was correlated with amygdala activation when participants watched happy faces. The more extrovert the individual, the greater the activation. No other interaction between emotion and personality was found. Illustrations can be seen in Plate 5.3.

Sugiura *et al.* (2000) made a more explicit examination of personality and brain activation. They used Cloninger’s (1986) concept of three heritable personality types and correlated these types with regional blood flow using SPECT. These three types are ‘novelty seeking’, a tendency towards seeking out novel stimuli and events; ‘harm avoidance’, a tendency to avoid punishment and harm because individuals respond intensely to such stimuli; and ‘reward dependence’, a tendency to seek reward and respond intensely to reward. Significant correlations between novelty seeking and brain activation were found in the left insula and the anterior cingulate cortex; a negative correlation was found between harm avoidance and activation in the left parahippocampal gyrus and regions of the frontal, temporal and parietal lobes; a negative correlation was also found between blood flow in the parahippocampal gyrus, the left insula, the anterior cingulate cortex and the frontal and temporal cortex and reward dependence scores.

The picture is therefore complex, perhaps not surprisingly given the febrile nature of personality and debate over whether it is a genuinely fixed, immutable quantity with reliable neural indices. Perhaps the biological basis of personality may be found at a more genetic level: for example, associations have been reported between serotonin transporter gene (5HTT or SERT) presence and neuroticism scores (Lesch *et al.* 1996). There are two variants of this gene – a long one and a short one. The short-allele version has been associated with high harm avoidance and neuroticism scores and lower agreeableness scores (Lesch *et al.* 1996; Greenberg *et al.* 2000), and also with depression (Mossner *et al.* 2001). If this allele is important to more ‘negative’ personality types, perhaps those with the allele might respond in a specific way when they view negative images, such as fearful faces. Predicting that viewing such faces would lead to greater amygdala activation in these allele carriers, Hariri *et al.* (2002) found this activation in an fMRI study of twenty-eight individuals.

The type of behaviour seen in EVR is also seen in many patients with orbito-frontal cortex damage. Cicerone and Tanenbaum (1997), for example, have reported the case of a 38-year-old woman with orbito-frontal damage who made good recovery from the injury but who showed disturbed social and emotional regulation. She appeared to have severe difficulty in integrating or appreciating subtle social and emotional cues. Hornak *et al.* (1996) have also reported twelve cases of ventral frontal lobe damage that was associated with an impairment in identifying facial and vocal emotional expression. Some of the comments made by orbito-frontal lobe patients on their disorder can help to illuminate the phenomenology of the social impairment – it shows us in very personal terms how the brain damage has affected that person’s behaviour. Some of the comments made by Hornak *et al.*’s (1996) patients are highlighted in Table 5.2. A more in-depth consideration of the consequences of frontal lobe damage on behaviour can be seen in the case study of NM.

Table 5.2 Some reflections of frontal lobe patients after their injury

Case 2

‘If I have something to say, I can’t wait and have to say it straight away’.

Case 4

‘Emotion, tears, that’s all gone out of the window. If I saw someone cry I’d just laugh – people look really silly getting upset’.

‘I’m much more aggressive and I feel less fear. I go fighting for no reason’.

‘Since I’ve taken up body building, I tend to show off a bit’.

Case 5

Anger and irritability had increased; anxiety had decreased.

Case 7

‘I ain’t scared of nobody. I’m not frightened of opening my mouth and speaking my mind. If I think someone’s in the wrong, I’ll tell them and not give a monkey’s what they think of me’.

Case 8

‘I’m not the woman he married; I’m much more outspoken’.

Source: adapted from Hornak *et al.* 1996.

Living with frontal lobe damage, 18 years on: the case of NM

When he was 22 years old, NM, a second-year student training to be a physical education teacher, sustained a head injury in a road traffic accident (Wood and Rutterford 2004). The injury was severe, and he suffered bilateral frontal damage (see Figure 5.10). NM was initially disoriented, agitated and restless in hospital, and was unable to concentrate. He lost his ability to smell, but at two months his physical recovery was good. Yet only weeks later, his personality and behaviour began to change subtly but perceptibly. In fact, his behaviour became very similar to that of Phineas Gage. NM reported feeling well, but he showed a tendency to become angry and irritable very quickly. His parents said that he had become a lot more outspoken since the accident and that he said what he thought, regardless of the consequences.

In the next nine months, although making a good recovery, NM would become irritable, agitated and lacking in concentration again and reported being extremely tired. At 15 months, his cognitive ability was good. He could complete cryptic crosswords, for example, and could hold conversations well. However, those around him felt that he acted extravagantly, was uninhibited and lacked social judgement: he would make comments or tell jokes that were socially inappropriate. He went to bed at a reasonable hour but would often not awaken until midday. His fatigue was compounded by his mental exertion: any task requiring great mental effort tired him out, although he denied any difficulty with tasks and with his college work. Conversations with his tutor revealed another picture: he failed to attend lectures, he was distractable and was only able to sustain attention for about 15 minutes.

Figure 5.10

The area of damage to NM's frontal cortex (image kindly supplied by Rodger L. Wood and reproduced by permission of Psychology Press)

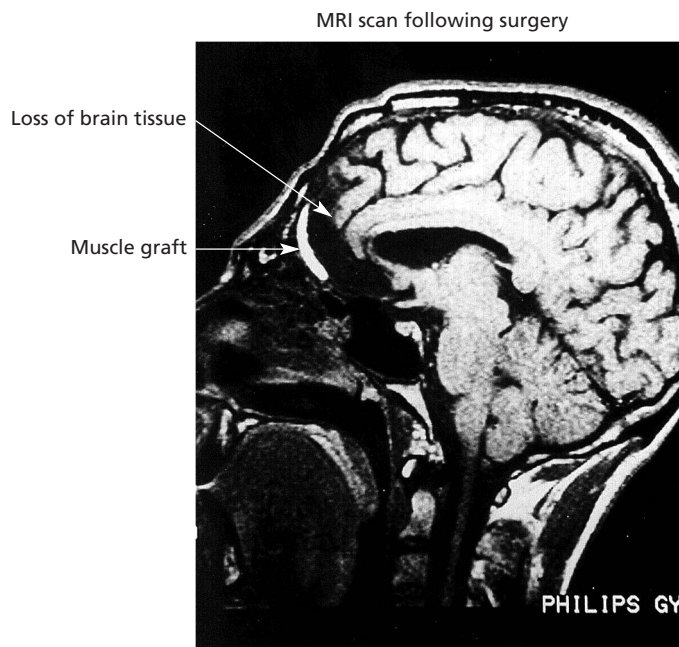

Many of his characteristics were similar to EVR's. He was unable to organize or initiate behaviour and lacked drive and motivation. He showed several examples of impulsiveness – on one occasion going out unexpectedly late at night and driving around aimlessly. He was indifferent to the feelings and concerns of others. Two years after the injury, he was referred for cognitive rehabilitation (the second time this had occurred). His non-verbal test performance surprised his clinicians because it was deficient, unlike previous test results. However, his family suggested a reason why this might be: NM would have good days and bad days, where his levels of alertness and stamina varied. On bad days, he was irritable and lethargic. Perhaps testing had occurred on a bad day.

He still had problems in organizing his life, in planning and in initiating goals. He also lacked tolerance, being quick to lose his temper (but would never engage in physical aggression). His rehabilitation allowed him to follow a structured routine by giving him a plan for his day, which included the organization of various activities. He began his rehabilitation with enthusiasm but would lose interest. He would fail to get up for morning meetings, despite phone call reminders, and would fail to attend when the rehabilitation meetings were scheduled for the afternoon. Despite having a printed programme of activities, he would fail to meet many of the goals in it.

Months later, and transferred to a specialist unit, he continued to be impulsive and unpredictable. However, he began to take greater care of himself, and there was an improvement in organization over the next three months.

Three to six years after his injury, he became one of Shallice and Burgess's (1991) patients (he was known as AD in this study), and his intelligence was found to be in the superior range. His parents described him as absent-minded, and his performance on an early version of the Six Elements Task and Multiple Errands Task was poor: poor time management characterized his performance.

Outwardly, though, NM was bright and amiable, if disinhibited and impulsive still: he acquired two motoring offence convictions for driving while under the influence and speeding. He seemed indifferent to the loss of his driving licence.

Over the next twelve years, NM's cognitive ability did not change – his performance was still in the superior range – but his behaviour did not change significantly either. He lived with his parents for nine years, then moved, met an old girlfriend and married her in 2000. The marriage gave him some stability, but his wife reported having to do all the housework and making most of the domestic decisions, as well as having to remind NM of his appointments. And, all the while, he was still impulsive. Wood and Rutterford (2004) describe an occasion when NM took his partner on holiday without thinking of the financial implications. He spent all of his money in two days. However, the impulsiveness no longer seemed to be coupled with disinhibition: this appeared to have attenuated. He continued to have a quick temper.

NM secured a full-time job as a barman in a snooker club, where he handled money and dealt with customers. However, he found taking multiple orders very difficult. At this point, his intellect was excellent, but he had problems in dividing attention. His Six Elements Test performance was normal (*cf.* 12 years earlier).

NM's social and organizational behaviour – unmeasured and un-noted by conventional neuropsychological testing – shows how neuropsychological assessment is not that sensitive to everyday difficulties in behaviour following brain injury. NM is even aware of social infelicities. On the Faux Pas Test, in which a *faux pas* is demonstrated

and the participant has to explain why it is a social gaffe, his performance is excellent. His theory of mind is intact.

NM's problems are common to frontal lobe patients. Another case study, AM, reported by Park *et al.* (2001), had suffered traumatic brain injury at the age of 45 that affected both frontal lobes. AM was university-educated, his speech was fluent, and his language was excellent. In fact, AM appeared so normal that his clinicians admitted that 'we did not realize he was a patient'. Like many frontal lobe patients, however, his irregular approach to everyday life and events emerged in conversation or in routine visits to the clinic. Park *et al.* recount how AM dispassionately reported the telephone conversation in which he was told that his daughter had been in an accident. Like NM, he ignored financial and legal obligations – bills would go unpaid, his car went uninsured, and court orders were left undealt with. His social judgement became questionable. After recalling how malicious his estranged wife had become, he would then express optimism that they might get back together (his wife had said that their marriage was well and truly over). He would make long-distance phone calls from the hospital, would walk into staff offices unannounced and would ignore non-verbal cues that signalled an end to a conversation or a meeting. Even when told to the point of rudeness that a meeting was at an end, he would continue talking.

The case of NM is relatively rare in that he has been followed up for a significant period following his original injury. The longitudinal nature of his recovery reveals much about the long-term consequences of brain injury that neuropsychological tests cannot.

Theories of frontal lobe function

Major theories of frontal lobe function include Luria's classical view, Norman and Shallice's supervisory system, Rolls's theory of orbito-frontal function and Damasio's somatic-marker hypothesis.

Luria's theory: the classical view

Luria (1973) regarded the frontal lobes as the third principal brain unit responsible for programming, regulating and verifying human behaviour, and the prefrontal cortex as the region that controlled the general state of the cortex and basic human mental activity.

Luria characterized the frontal lobes as a tertiary zone that regulated the organism's state of activity when it carried out a mental process. One of the most important functions of the frontal lobes was 'the disturbance of the operation of comparing the result of an action with its original intention, or disintegration of the "action acceptor" function'. This is perhaps the most obvious manifestation of frontal cortex damage. Luria went on to emphasize that the prefrontal zones were important for forming plans and for acting on the consequences of these plans. When complex programmes of activity are disrupted by frontal cortex damage, simpler, more basic forms of behaviour might replace them, or they might be replaced by stereotypical behaviour that is either irrelevant to the situation or

illogical. A number of subsequent theories have incorporated Luria's ideas in some form.

Luria also noted that damage to the lateral portion of the frontal lobes caused disruption to motor behaviour, because this region was connected to the motor structures. Damage to regions linked to the limbic system and reticular formation led to disinhibition and changes in affect.

The notion that prefrontal lobe patients have difficulty in disregarding or inhibiting irrelevant information, i.e. their online cognitive processes are disrupted, has been incorporated into a theory of frontal lobe function that suggests that the prefrontal cortex modulates activity by means of a dynamic 'filtering' or 'gating' mechanism (Shimamura 1995). This filtering or gating inhibits irrelevant information. The reason why different symptoms follow damage to different parts of the prefrontal cortex, the theory argues, is not because each region is responsible for the disrupted function but because different connections within the prefrontal cortex are filtering different aspects of cognition. This mechanism should inhibit irrelevant search strategies when trying to remember the temporal order of events, for example, but would be disrupted in prefrontal patients. The theory receives some backing from physiological evidence indicating that the frontal lobes have an inhibitory effect on posterior brain regions (as we saw with corollary discharge and utilization behaviour). Frith *et al.* (1991), for example, noted that in their PET study, increases in the dorso-lateral prefrontal cortex were related to decreases in the posterior cortical regions. Based on this evidence, it is possible that different prefrontal symptoms arise because different areas of the cortex are inhibiting different posterior cortical areas. Thus attention problems become a failure to inhibit irrelevant stimulus information; memory impairments become a failure to inhibit previous memories; and problem-solving difficulties become a failure to inhibit irrelevant or incorrect search strategies. This is an idea that deserves further investigation.

Norman and Shallice's supervisory attentional system

Norman and Shallice's (1986) theory of frontal lobe function and dysfunction is based on a similar idea to that of Luria: that the frontal lobes programme, regulate and verify activity. The theory assumes that the processes involved in the cognitive control of action and thought can be divided into two systems: contention scheduling and a supervisory attentional system (SAS). Contention scheduling controls the execution of ordered or routine actions or skills, so action schemata (plans of action) or well-defined sets of responses associated with specific environmental stimuli or triggers are selected when a threshold specific to that schema is activated. The SAS, on the other hand, provides the conscious attentional control needed to modulate performance and may be employed in non-routine operations.

The inhibitory control scheduling prevents two competing schemata requiring the same resource from being selected. It is the job of the SAS to influence the probability of a schema being selected by contention scheduling. Furthermore, the SAS is required for situations (1) involving planning/decision making, (2) involving error correction, (3) requiring responses that are neither well learned nor familiar, (4) considered to be dangerous or difficult, and (5) requiring the organism to ignore strong habitual responses. Supervisory processes thus involve responsibility for formulating or modulating plans, creating markers or triggering, evaluating and articulating goals. It is a breakdown in one or more of these processes that may occur with frontal damage. As a result, the SAS is probably not a unitary system but a fractionated one.

One instance where there is clearly inadequate control by the frontal systems over behaviour is utilization behaviour (UB). According to the Norman and Shallice model, when no strong schema exists, then actions would be triggered by irrelevant environmental cues, which is what appears to happen in UB. There is some strong support for Norman and Shallice's system and, as we see below, the model is closely related to the 'central executive' of working memory.

Rolls's theory of orbito-frontal function: stimulus–reward

Rolls's (1990, 1995) theory of frontal lobe function is directed more at explaining the neural basis of emotion than cognition, hence the emphasis on the orbito-frontal cortex. Rolls regards emotions as states produced by instrumental reinforcing stimuli. Some stimuli are unlearned reinforcers (pain, taste of food); other stimuli become reinforcers because of their association with primary reinforcers and are thus called secondary reinforcers. Thus types of learning result from stimulus–reinforcement associations. A positive reinforcer is a reward, and a negative reinforcer is punishment or the omission or termination of a positive reinforcer.

This theory argues that frontal lobe damage results in a failure to react normally to non-reward in different contexts. Thus inappropriate responses to stimuli will appear when those responses are not rewarded. For example, both monkeys and humans with frontal cortex damage may show impairment at the go/no go task (Iversen and Mishkin 1970), whereas monkeys may either make an incorrect response to an object because that object was previously rewarded with food or may fail to realize that a response will not provide them with a reward (Butter 1969). This latter task illustrates the concept of extinction: a response is extinguished because it is not reinforced or rewarded.

Rolls argues that the orbito-frontal cortex is involved in correcting responses made to stimuli that were previously associated with reinforcement. Support for this comes from studies in which some neurons responded during the extinction task while others responded in the reversal task. These responses are thought to reflect information that the expected reward has not been made. This information is essential for the primate's ability to change behaviour if a response is contingent on changes in the environment. Neurons also selectively respond to different sensory stimuli and may also respond if responses to these stimuli had previously been rewarded. Finally, the orbito-frontal cortex is thought to evaluate whether a reward is expected and generates a mismatch (as seen in the firing of non-reward cells) if an expected reward is not obtained. The orbito-frontal cortex corrects stimulus–reinforcement associations when they become inappropriate. Rolls's model is based almost exclusively on animal work, although the human literature suggests that the alteration of inappropriate responses is impaired following frontal cortex damage.

Damasio's somatic marker hypothesis

Damasio's model of frontal lobe function attempts to explain the role of the frontal cortex in emotion and social behaviour. The case of Phineas Gage suggested that emotion and the neural mechanisms responsible for emotion may be implicated in making social decisions. As the damage to Phineas Gage's brain involved the ventro-medial (orbito-frontal) cortex, emotion and its neural machinery's participation in making decisions in a social context depend on an intact ventro-medial system (Damasio *et al.* 1994). The involvement of emotion is further suggested by the ventro-medial cortex's links, via the

medio-dorsal nucleus of the thalamus, with the amygdala and hypothalamus, two collections of subcortical nuclei heavily implicated in emotional processing. Furthermore, dorso-lateral lesions that do disrupt the ability to perceive extrapersonal space/objects and to produce language do not impair emotional behaviour.

Damasio (1995) has suggested a somatic marker hypothesis to account for the emotional changes seen after orbito-frontal cortex damage. This states that although the patient may be able to understand the implications of inappropriate social behaviour, EVR-type patients are unable to mark these implications with a signal that automatically distinguishes between appropriate and inappropriate actions. EVR's deficit may be attributable to the inability to choose a course of appropriate action or to implement it.

According to the theory, this deficit results from a failure to activate certain specific somatic states (visceral and skeletal) that were activated or evoked at the time of social learning. In other words, social learning is derived from punishment or reward associations. These associations modify somatic states, and these modifications in turn are dispatched to other brain areas, such as the sensory and limbic association cortices. This signalling enables the consequences of reward or punishment to be experienced as 'feelings' and 'emotions'. This hypothesis is partly supported by Damasio's recent study of risk taking in frontal lobe patients (Bechara *et al.* 1997). In this experiment, healthy individuals and patients with bilateral ventro-medial prefrontal cortex damage participated in a task that required them to turn the cards from four decks of cards. In two decks, turning up certain cards was rewarded with \$100; in the other two the reward was lower (\$50). In the high-reward condition, however, there was a higher penalty for turning over specific cards compared with the low-reward deck. Damasio and his colleagues found that although the healthy controls had, by card 50, realized that the high-reward deck was also a lot riskier and generated anticipatory skin conductance response (SCR) when considering choosing a card from those decks, this 'hunch' and the anticipatory SCR was absent in the frontal lobe patients. Three patients could correctly identify the 'bad' decks but continued to make disadvantageous choices; they also did not exhibit the normal anticipatory autonomic response. Damasio interprets this as indicating that autonomic response reflects a process of 'non-conscious signalling' that represents access to records of previous events and behaviour related to reward and punishment.

This theory has parallels with Rolls's orbito-frontal cortex theory in that they both attribute the experience of emotion to stimulus-response associations and both emphasize the role of the ventro-medial, and not the dorso-lateral, cortex in the formation of these associations.

Discussion point: are psychopathy and frontal lobe damage related?

The frontal lobe literature suggests some patients show quite clear impairments in affective response after frontal lobe damage, becoming depressed or euphoric or obscene or listless and so on. In the past fifteen years, a small body of evidence has suggested that not only might the frontal lobes be involved in emotional disturbance but also, more controversially, they might be implicated in the development of psychopathy and antisocial behaviour (Raine 1993).

According to Hare (1996), psychopaths can be described as ‘intraspecies predators who use charm, manipulation, intimidation, and violence to control others and to satisfy their own selfish needs. Lacking in conscience and in feelings for others, they cold-bloodedly take what they want and do as they please, violating social norms and expectations without the slightest sense of guilt or regret’ (p. 26). Their symptoms include:

- superficial charm
- egocentricity
- incapacity for love
- guiltlessness
- lack of remorse and shame
- lack of insight
- failure to learn from experience
- inability/unwillingness to use deep meaning of language
- lack coherence/logical consistency in narratives
- intense eye contact
- knowledge of victim’s vulnerabilities
- appearance of knowledgeability until questioned.

Although the distinction has not been made in DSM-IV, there is a qualitative and demonstrable difference between psychopathy and antisocial personality disorder or APD (Hare 1991). Whereas psychopaths show the typically antisocial characteristics of the personality-disordered (commission of physical assault or crimes of theft), those with APD do not exhibit any of the cognitive or emotional symptoms of the psychopath, such as lack of remorse, incapacity for love and guiltlessness.

Psychopaths actually perform badly on some ‘frontal lobe’ tests, including the Porteus Maze Test (Schalling and Rosen 1968), a remunerated card-sorting task (Newman *et al.* 1987) and the WCST (Gorenstein 1982). However, these results are by no means consistent with other studies reporting no differences between psychopathic and non-psychopathic individuals (Hare 1984; Hoffman *et al.* 1987).

Lapierre and colleagues compared the performance of thirty psychopathic and non-psychopathic individuals on what they described as ‘orbito-frontal’ and ‘ventro-medial’ tasks (go/no go task; Porteus Maze; anosmia), ‘frontodorso-lateral measures’ (the WCST) and ‘posteriorolantic measures’ (mental rotation). While there was no significant difference between the groups on the WCST and mental rotation, there was a significant difference on all three ventro-medial tasks. In each test, the psychopaths were significantly impaired, even in the test requiring olfactory identification (Lapierre *et al.* 1995).

These results suggest that group differences, where such differences exist, are likely to be found on tests of orbito-frontal ability (go/no go task) rather than dorso-lateral ability (WCST). EVR, you will recall from the case study, had ventro-medial lesions and a sparing of the dorso-lateral cortex: his social behaviour was disrupted, yet he could perform well on ‘frontal lobe’ tests. In his review of the neuropsychology of psychopathy, Raine (1993) concluded that the available evidence suggests that prefrontal dysfunction indicates a predisposition to crime and antisocial behaviour.

In what they describe as the 'first evidence for a structural brain deficit in antisocial personality disorder' (APD), Raine *et al.* (2000) compared the brain volume of twenty-one community volunteers with the DSM-IV ratified APD with control groups. The experimental sample was derived from five temporary employment agencies in Los Angeles known to have clients who commit high levels of violence. The control groups comprised psychiatric controls, healthy individuals and substance abusers. In addition to the brain scanning, participants also had their behaviour videotaped as they talked about their faults (a social stressor). During this task, their skin conductance and heart rate was recorded.

The prefrontal brain volume of the APD group was 11 percent less compared with the other groups. They also showed little autonomic response when undertaking the social stressor task. Both of these findings are consistent with evidence from brain-damaged individuals, showing that frontal lobe patients have social problems and are unresponsive to threatening or risky behaviour when this response is measured autonomically.

A study from University College London has partly supported the notion that frontal cortex dysfunction is involved in antisocial behaviour (Blair and Cipolotti 2000). Patient JS was a 56-year-old electrical engineer who had collapsed with trauma to the orbito-frontal cortex. After this episode, he began to behave very bizarrely – he was uncooperative with hospital staff, generally aggressive and rode around on hospital trolleys. His performance on typical frontal lobe tests was impaired. He had difficulty in recognizing emotional expression, especially expressions of anger and disgust, and he failed to attribute appropriate emotions (such as fear, anger and embarrassment) to characters in stories. He failed to identify antisocial behaviour when presented with it.

Ruling out most of the existing explanations of behaviour change following frontal lobe damage (such as the inability to inhibit behaviour or engage in abstract thinking), Blair and Cipolotti suggest that we normally have a system that is activated by someone's anger. This system gets rid of current behaviour and switches one response for another. This system is activated by representations of situations in which other people have expressed anger or where we have experienced embarrassment. Such a system is damaged in JS, the authors argue: he cannot retrieve representations in which another's anger is anticipated. So he failed to attribute negative emotions to characters in stories because he was unable to summon up similar experiences or representations of such experiences.

Raine and his group followed up their fMRI study with an investigation of individuals similar to those with APD (Ishikawa *et al.* 2001). According to Hare (1996): 'In some respects, it is as if psychopaths lack a central organiser to plan and keep track of what they think and say' (p. 46). The part of the brain that is more responsible than any other for monitoring, organizing and integrating sensory input and behaviour is the frontal cortex. People with damage to the frontal cortex have also been shown to exhibit irregularities in autonomic nervous system functioning, such as a lack of heart rate responsiveness and galvanic skin response in contexts that require an assessment of risk.

To date, studies have focused on 'unsuccessful' psychopaths, i.e. those that have been caught and jailed. It has been suggested that successful psychopaths – those who are not caught and jailed – are behaviourally very similar to their incarcerated counterparts but are physiologically different (Widom 1978). Ishikawa *et al.* recruited people from temporary employment agencies and administered the Hare Psychopathy

Checklist to determine the sample's degree of psychopathy. Those scoring in the top (most psychopathic) and bottom third were selected. The top third were divided into those who had been convicted of a crime ($N = 17$) and those who had not ($N = 13$). Heart rate and electrodermal response was measured.

The researchers found that when compared with the control group, the successful psychopaths showed heightened heart rate activity and performed better than the unsuccessful psychopaths at a test of frontal lobe function. The authors suggest that this reactivity reflects the successful psychopath's greater awareness of changes in the social environment – they are better than unsuccessful psychopaths at assessing or making risky decisions; unsuccessful psychopaths show little ANS reaction to risk, and it may be this lack of feedback from the ANS that leads to their slipping up.

A note of caution, however. Commenting on Raine *et al.*'s (2000) findings, Antonio Damasio (2000) interjects: 'One must be careful not to fall in the phrenological trap set behind every new identification of a brain area with some putative role The normal or pathologic effects associated with that certain area can be properly understood only in the context of multicomponent neural systems'. This argument is taken up in Chapter 10.

Summary

The frontal lobes comprise about one-third of the human neocortex and are the most recently developed region. Their principal roles are the regulation of ongoing behaviour and the planning and maintenance of goals (so-called executive functions). The frontal lobes are also thought to regulate social behaviour and inhibit inappropriate responses. Because they contain the premotor cortex, they are also involved in planning and executing voluntary movement. Several tests are used to measure frontal lobe dysfunction. The commonest type of test is the controlled oral word association test. Other tests include the Wisconsin Card Sorting Test, the Tower of London task, go/no go tasks and the Porteus Maze. Not all frontal lobe patients perform poorly: some, such as EVR, perform well, which casts doubt on the validity of these tests as 'frontal lobe' tests. Prefrontal symptoms include an inability to behave spontaneously, as evidenced by performance on verbal fluency tasks, the inability to plan, form strategies and execute these strategies effectively, an inability to shift response strategy, a failure to maintain attention, the unprompted utilization of objects in the environment, poor free memory recall and impaired working memory. A number of theories has attempted to explain the function of the frontal lobes. According to Luria's classical view, the frontal lobes are a tertiary zone that allows the individual to plan and organize behaviour. Norman and Shallice's supervisory attentional system views the frontal lobes as reflecting the activity of contention scheduling (which controls the execution of actions) and a supervisory attentional system (which provides conscious attentional control needed to change behaviour). Inadequate control leads to frontal lobe symptoms. Rolls's theory of frontal lobe function focuses on the orbito-frontal cortex and its involvement in reward/punishment behaviour. Frontal lobe damage results in changes related to a failure to react normally to the absence of a reward in various situations. Damasio's somatic marker hypothesis argues that although patients might be able to understand the implications of inappropriate social behaviour, they are unable to mark these implications with a signal that can help to distinguish between appropriate and inappropriate behaviour. There is a failure to activate specific somatic states that were activated at the time of social learning.

Recommended further reading

Frontal lobes and cognition

- Bechara, A., Damasio, H., Tranel, D. and Damasio, A.R. (1997). Deciding advantageously before knowing the advantageous strategy. *Science*, 275, 1293–369.
- Burgess, P.W. and Alderman, N. (2004). Executive dysfunction. In L.H. Goldstein and J.E. McNeil (eds), *Clinical Neuropsychology: A Practical Guide to Assessment and Management for Clinicians*. Chichester, UK: John Wiley and Sons.
- Burgess, P.W., Alderman, N., Evans, J., Emslie, H. and Wilson, B.A. (1998). The ecological validity of tests of executive function. *Journal of the International Neuropsychological Society*, 4, 547–58.
- Chevignard, M., Pillon, B., Pradat-Diehl, P., Taillefer, C., Rousseau, S., LeBras, C. and Dubois, B. (2000). An ecological approach to planning dysfunction: script execution. *Cortex*, 36, 649–69.
- Clarke, H.F., Dalley, J.W., Crofts, H.S., Robbins, T.W. and Roberts, A.C. (2004). Cognitive inflexibility after prefrontal serotonin depletion. *Science*, 304, 878–80.
- Crawford, J.R. and Henry, J.D. (in press). Assessment of dysexecutive dysfunction. In P.W. Halligan and N. Wade (eds), *The Effectiveness of Rehabilitation for Cognitive Deficits*. London: Oxford University Press.
- Duncan, J. and Owen, A.M. (2000). Common regions of the human frontal lobe recruited by diverse cognitive demands. *Trends in Neurosciences*, 23, 10, 475–83.
- Eskes, G.A., Szostak, C. and Stuss, D.T. (2003). Role of the frontal lobes in implicit and explicit retrieval tasks. *Cortex*, 39, 4/5, 847–69.
- Fletcher, P.C. and Henson, R.N.A. (2001). Frontal lobes and human memory. *Brain*, 124, 849–81.
- Funahashi, S. (2001). Neuronal mechanisms of executive control by the prefrontal cortex. *Neuroscience Research*, 39, 147–65.
- Gallagher, H.L. and Frith, C.D. (2003). Functional imaging of ‘theory of mind’. *Trends in Cognitive Science*, 7, 77–83.
- Grafman, J. (2002). *The Frontal Lobes*. Oxford: Academic Press.
- Manes, F., Sahakian, B., Clark, L., Rogers, R., Antoun, N., Aitken, M. and Robbins, T. (2002). Decision-making processes following damage to the prefrontal cortex. *Brain*, 125, 624–39.
- Odhuba, R.A., van den Broek, M.D. and Johns, L.C. (2005). Ecological validity of measures of executive functioning. *British Journal of Clinical Psychology*, 44, 269–78.
- Rowe, A.D., Bullock, P.R., Polkey, C.E. and Morris, R.G. (2001). ‘Theory of mind’ impairments and their relationship to executive functioning following frontal lobe excisions. *Brain*, 124, 600–16.
- Special issue of *Brain and Cognition* (2004), Vol. 55, on ‘Development of orbitofrontal function’.
- Tanji, J. and Hoshi, E. (2001). Behavioural planning in the prefrontal cortex. *Current Opinion in Neurobiology*, 11, 164–70.
- Ward, J. (2003). Encoding and the frontal lobes: a dissociation between retrograde and anterograde amnesia. *Cortex*, 39, 4/5, 791–812.

Frontal lobes, emotion and social behaviour

- Adolphs, R. (2001). The neurobiology of social cognition. *Current Opinion in Neurobiology*, 11, 231–9.
- Adolphs, R. (2003). Investigating the cognitive neuroscience of social behavior. *Neuropsychologia*, 41, 119–26.
- Bechara, A. (2001). Neurobiology of decision-making: risk and reward. *Seminars in Clinical Neuropsychiatry*, 6, 205–16.

- Berlin, H.A., Rolls, E.T. and Kischka, U. (2004). Impulsivity, time perception, emotion and reinforcement sensitivity in patients with orbitofrontal cortex lesions. *Brain*, 127, 1108–26.
- Blair, R.J.R. and Cipolotti, L. (2000). Impaired social response reversal: a case of ‘acquired sociopathy’. *Brain*, 123, 1122–41.
- Damasio, H., Grabowski, T., Frank, R., Galaburda, A. and Damasio, A.R. (1994). The return of Phineas Gage: clues about the brain from the skull of a famous patient. *Science*, 264, 1102–05
- Dolan, R.J. (1999). On the neurology of morals. *Nature Neuroscience*, 2, 11, 927–9.
- Eslinger, P.J. and Damasio, A.R. (1985). Severe disturbance of higher cognition after bilateral frontal ablation: patient EVR. *Neurology*, 35, 1731–41.
- Goel, V., Shuren, J., Sheesley, L. and Grafman, J. (2004). Asymmetrical involvement of frontal lobes in social reasoning. *Brain*, 127, 783–90.
- Harlow, J.M. (1848). Passage of an iron rod through the head. *Boston Medicine and Surgery Journal*, 39, 389–93.
- Insel, T.R. and Fernald, R.D. (2004). How the brain processes social information: searching for the social brain. *Annual Review of Neuroscience*, 27, 697–722.
- Macmillan, M. (1996). Phineas Gage: a case for all reasons. In C. Code, C.-W. Wallesch, Y. Joannette and A.R. Lecours (eds), *Classic Cases in Neuropsychology*. Hove, UK: Psychology Press.
- Raine, A., Lencz, T., Bihle, S., LaCasse, L. and Colletti, P. (2000). Reduced prefrontal gray matter volume and reduced autonomic activity in antisocial personality disorder. *Archives of General Psychiatry*, 57, 119–27.
- Stuss, D.T., Gow, C.A. and Hetherington, C.R. (1992). ‘No longer Gage’: frontal lobe dysfunction and emotional changes. *Journal of Consulting and Clinical Psychology*, 60, 3, 349–59.
- Tranel, D., Bechara, A. and Denburg, N.L. (2002). Asymmetric functional roles of right and left ventromedial prefrontal cortices in social conduct, decision-making, and emotional processing. *Cortex*, 38, 589–612.

6

Disorders of perception

- Introduction
- Blindsight
- Agnosia
 - Visual agnosia
 - Apperceptive visual agnosia
 - Farah's classification of agnosia
 - Associative visual agnosia
 - Optic aphasia
 - Colour agnosia
 - Theories of visual agnosia
 - Apperceptive agnosia
 - Associative agnosia
 - Category-specific visual agnosia
 - Prosopagnosia
 - Locus of damage
 - Covert recognition in prosopagnosia
 - Amygdala and face processing
 - Models of face processing
 - Landmark agnosia
- Auditory agnosia
 - Pure word deafness
 - Auditory sound agnosia
 - Receptive amusia
- Somatosensory agnosia
- Unilateral spatial neglect
 - Tests of spatial neglect
 - Factors influencing spatial neglect
 - Reducing spatial neglect
 - Location of lesions in spatial neglect
 - Explanations for spatial neglect
- Summary
- Recommended further reading

Introduction

Previous chapters have examined some of the cognitive and social consequences of brain damage and brain surgery. Localization of function is sometimes possible at the crude level (hemispheric) or at a more specific level (structural or neural). This is more clearly and straightforwardly seen in the sensory and motor systems, where damage to certain

brain regions is associated with predictable and explicable sensory or motor deficits. However, from a neuropsychological point of view there are other disorders related to the sensory and perceptual systems that are arguably more interesting, not least because of the unusual problems they present. These disorders are principally disorders of perception: brain damage has resulted in a clear deficit in perception despite adequate sensation and relatively unimpaired language ability. The most well-documented perceptual disorder is agnosia (literally, without knowledge), a condition in which a patient is unable to recognize stimuli belonging to a particular sensory modality. For example, a patient may not be able to recognize an object by sight (visual agnosia) or sound (auditory agnosia) or touch (tactile agnosia), despite having unimpaired language and sensation. This phenomenon, and others like it, is examined in this chapter, beginning with one of the most unusual of the perceptual disorders.

Blindsight

Patients with agnosia typically have relatively intact sensation. However, there are other patients who have a recognized sensory impairment such as cortical blindness but who present a more unusual problem: they appear able to make simple perceptual decisions about visual stimuli despite claiming to be unaware of stimuli and despite the absence of the part of the brain responsible for higher visual functioning, the striate cortex. This phenomenon is called blindsight, a term coined by Sanders *et al.* (1974), who reported that damage to the striate cortex appeared to impair the ability to ‘see’ objects but not the ability to locate apparently unseen objects. There are similar phenomena in the somatosensory and auditory systems called numbsense/blindtouch and deaf hearing, respectively, and a case study of deaf hearing is described in the box. Sanders *et al.*’s report followed a study by Pöppel *et al.* (1973), which found that some patients with

Deaf hearing: the case of SB

Individuals with blindsight claim not to be able to see objects but nonetheless show evidence of being aware of visual stimuli. A similar phenomenon occurs in the auditory system – a phenomenon known as ‘deaf hearing’. Individuals have damage to the auditory cortices, but although they appear to be deaf, they seem to show deficits in auditory recognition rather than full-blown deafness.

In the first study of its kind, Engelein *et al.* (2000) reported on patient SB, who was a 22-year-old right-handed man who had suffered two consecutive strokes which damaged the parts of the cortex responsible for hearing. When SB was instructed to pay attention to sounds, he appeared to show awareness of them; when he was not explicitly instructed to pay attention to them, his awareness was poor. Galvanic skin response (a measure of arousal) was observed only when he explicitly paid attention to sounds.

Engelein *et al.* found that when SB paid attention to sound, there was activation in the frontal cortex, what was left of the temporal cortex, and the cerebellum. All activity was bilateral. These results indicate that the primary auditory cortex may not be necessary for the conscious awareness of sounds, in the same way that the primary visual cortex may not be necessary for the conscious awareness of sights.

gunshot wounds reported no visual experience but were able to make small eye movements towards visual objects. A phenomenon called blindsight type 2 – in which a patient may be aware of a stimulus but does not report the experience as a visual sensation – has also been reported (Weiskrantz 1998).

The earliest cases of blindsight were reported at the beginning of the last century (Holmes 1918; Riddoch 1917). Holmes's patients, for example, could identify objects but were unable to notice them when in visual range. They were also unable to follow a moving object with their eyes. Riddoch reported patients who were apparently blind but who could grasp moving objects or indicate the direction of movement despite reporting being unable to see the objects.

The blindness in these patients need not necessarily be complete. Damage to the striate cortex can produce areas of complete blindness called scotomas. Blindsight patients can discriminate some stimuli in these areas but report being unaware of the stimuli presented. One of the most celebrated cases of blindsight is that of patient DB, whose behaviour has been extensively reported by Oxford psychologist Larry Weiskrantz (1986). DB required surgery to remove an arterio-venous malformation in his right occipital lobe. The removal of the right striate cortex resulted in a left visual field scotoma, specifically in the lower left quadrant of his visual field. Although appearing unaware of stimuli presented in his blind field of vision, DB performed well above chance on a number of simple perceptual tasks. These included indicating whether a stick was horizontal or vertical, detecting the location of a stimulus by pointing at it, being able to detect the presence or absence of a stimulus and distinguishing between certain shapes (such as a cross from a circle). On other tasks he performed poorly. For example, he was unable to distinguish a triangle from a cross or a curved triangle from a normal one. However, more important was his lack of awareness of any stimuli presented to him. According to DB, he 'couldn't see anything' when the test stimuli were presented in his impaired visual field, a phenomenon that suggests that the processes of being able to see and being aware of what is seen are possibly dissociable.

A number of hypotheses has sought to try to explain blindsight. *Campion et al.* (1983), for example, suggest that perceptual tasks can be completed successfully, at above chance levels, because stray light reflected by stimuli makes its way from the intact field of vision to the scotoma because it reflects from surfaces outside the eye area – what is called extraocular scatter. In their study, the participant could detect stimuli in the blind visual field because light was reflected from the side of the nose. Cowey (2004) has suggested that one way of controlling for this light scatter is to mask the blind field from view by placing a half-patch over the viewing eye, but this control is rarely employed. There can also be an intraocular source of light scatter – according to Cowey (2004), visual stimuli always 'smear' the retina. Because stimuli in blindsight studies have been presented very close to the eye, this has allowed the retina to be smeared with the image and stimulate the retina, leading to crude visual perception.

However, the stray light hypothesis appears to be an unlikely explanation, because DB is able to make perceptual decisions in the presence of strong ambient light, which reduces the amount of stray light reflected by stimuli. More to the point, this theory does not explain how DB can still make decisions based on the spatial dimensions of objects.

An alternative hypothesis suggests that the residual perceptual abilities of patients such as DB are attributable to the degrading of normal vision, possibly due to the presence of some residual striatal cortex. Implicit in this hypothesis is the notion that residual abilities are not attributable to the functioning of another visual system pathway. There are ten known pathways from the retina to the brain (Stoerig and Cowey 1997). As you saw in

Chapter 3, there appear to be two distinct pathways in the visual system that mediate different aspects of vision. The visual location of objects, for example, is thought to be a function of a system that includes the superior colliculus, the posterior thalamus and areas 20 and 21, whereas the analysis of visual form, pattern or colour is thought to be a function of the geniculostriate system, which sends projections from the retina to the lateral geniculate nucleus, then to areas 17, 18 and 19, and then to areas 20 and 21. Blindsight could therefore conceivably be due to a disconnection between these two systems. Again, there are arguments against this hypothesis.

Primates with their striate cortex removed exhibit blindsight. DB also showed variable performance depending on the area of the scotoma that the stimuli were presented in. For example, he was better at distinguishing a blank stimulus from a grating than at discriminating between a cross and a triangle in one region of the scotoma, but he exhibited the opposite pattern when the stimuli were presented in a different region. Curiously, DB, although unable to 'see' objects when presented to him – even thirty years after his deficit was first studied – appears to be aware of a visual 'after-image' after a stimulus on a monitor is switched off (Weiskrantz *et al.* 2002). The colour and spatial structure of the stimulus can be described, a phenomenon that is correlated with increased prefrontal cortex activity (Weiskrantz *et al.* 2003). It is unclear whether this ability is due to spared striate cortex, however, because DB has surgical clips that prevent him undergoing an MRI scan, which would demarcate the preserved cortex.

Patient GY has no spared striate cortex but still exhibits signs of blindsight (Azzopardi and Cowey 2001). When the visual cortex of blindsight patients with spared striate cortex is imaged, no activation is observed to visual stimuli that produce the blindsight phenomenon (Storeig *et al.* 1998). Both lines of evidence suggest that the spared striate cortex explanation is weak (although not completely dismissible – perhaps the degree and type of spared cortex are the important factors).

What seems intuitively correct, but for which there is no hard evidence, is the hypothesis that what is at work in blindsight is a primitive, early visual system that is not dependent on the striate cortex. A note of caution should be struck, however. Blythe *et al.* (1987), for example, found only five cases of blindsight in a sample of twenty-five patients; Marzi *et al.* (1986) found a similar ratio (four patients out of twenty) in their sample. The degree of variability in the appearance of blindsight following striate removal therefore suggests some restraint in extrapolating from individual cases.

Agnosia

According to Bauer (1993), agnosia is classically defined as a 'failure of recognition that cannot be attributed to elementary sensory defects, mental deterioration, attentional disturbances, aphasic misnaming, or unfamiliarity with sensorially presented stimuli'. Sometimes, brain damage can affect aspects of sensation such as determining the presence or absence of light, detecting changes in contrast (acuity), discriminating between shapes (shape discrimination) or perceiving colour. Patients unable to perceive colour exhibit achromatopsia and describe the world as being drained of colour or grey. The classical diagnosis of agnosia dictates that these sensory deficits are absent.

The most commonly studied of the agnosias are visual agnosia, auditory agnosia and tactile agnosia, and clear modality specificity is normally observed, i.e. a person unable to recognize an object by sight will be able to name the object if allowed to palpate it. The principal agnosias are summarized in Table 6.1.

Table 6.1 The principal agnosias and their neural basis

Agnosia	Locus of damage
Apperceptive visual agnosia	RH parietal or temporal lesions
Associative visual agnosia	LH posterior lesions
Optic aphasia	LH parieto-occipital lesions
Colour agnosia	
Central achromatopsia	Unilateral inferior occipital lesion Lingual/fusiform gyri lesions
Prosopagnosia	RH posterior lesions Possible parahippocampal gyrus, lingual/fusiform gyri and splenium lesions
Auditory agnosia	
Pure word deafness	Bilateral, symmetrical cortico-subcortical lesions of the anterior temporal gyri
Auditory sound agnosia	Parietal lobe lesions Temporal and angular gyri lesions
Somatosensory agnosia	
Tactile agnosia	Contralateral postcentral gyrus and motor cortex hand area lesions

RH = right hemisphere; LH = left hemisphere

Visual agnosia

In visual agnosia, there is a severe inability to recognize visual stimuli despite intact sensory abilities. According to Lissauer (1890), agnosia manifested itself in two distinct forms: apperceptive agnosia and associative agnosia (Lissauer originally termed them apperceptive mindblindness and associative mindblindness). For example, apperceptive agnosia described an inability to recognize visual objects owing to some deficit in perceptual processing. However, associative agnosia described a disorder in which perception was relatively normal but the process of associating an object's percepts with its meaning was impaired. It was Freud (1891) who introduced the term 'agnosia', arguing that the deficits seen in mindblindness could be considered not only sensory disorders but also impairments in existing knowledge of objects. Agnosia was the inability to bring together visual elements into a complete, recognizable whole. The visual agnostic is unable to identify or recognize visually presented material. The deficit is present despite unimpaired language (so anomia is excluded as an explanation), and it can appear in a number of guises.

These two general distinctions (apperceptive versus associative) exist in the literature to this day, although researchers have delineated more specific types of agnosia falling

under each category. However, there is controversy surrounding the use of these two terms. For example, it has been suggested that apperceptive agnosia has ‘fuzzy boundaries’ that make it less distinguishable from associative agnosia (De Renzi and Lucchelli 1993). Farah (1991) suggests that the difference between the deficits symptomatic of the two disorders is one of level of processing. That is, the description of absence or presence of symptoms as a means of distinguishing between the two types is not practicable. She draws this conclusion on the basis of studies that suggest that even associative agnosia may be reflective of subtle perceptual impairments, specifically the inability to see the whole of an object simultaneously. These studies and others like them are reviewed in the remainder of the chapter.

Apperceptive visual agnosia

Apperceptive agnosia (or visual object agnosia) refers to the inability to recognize objects owing to a deficit in forming stable representations or percepts of a visual stimulus. It commonly results from carbon monoxide or mercury poisoning, cardiac arrest, stroke or bilateral posterior cortical atrophy. Apperceptive agnosics are unable to copy drawings or match objects, although they are able to identify objects and drawings. Persons with visual agnosia have intact visual acuity, which distinguishes them from patients with Anton’s syndrome, which is characterized by a denial of blindness. Degraded or incomplete objects, pictures or letters are difficult to identify. On the Gollin test (Gollin 1960), which requires the identification of a drawn object whose features are successively revealed, patients require a more complete picture than do controls before being able to identify the object (Warrington and Taylor 1973). Alterations in the lighting conditions make tasks difficult for these patients. Shadows cast by objects, for example, make the stimuli more unidentifiable (Warrington 1982). Patients also have greater difficulty in identifying objects from ‘unusual’ perspectives, performing more poorly than controls (Warrington and Taylor 1973). These impairments are associated with right inferior parietal lobe lesions. Stimuli that involve complex shape and pattern present the most difficulty, however. Usually, the patient is unable even to point to a named object. Interestingly, these recognition deficits may be alleviated if stimuli are moved while identification is attempted.

This impairment in complex shape and pattern identification highlights one of the controversial issues in agnosia. According to Warrington, any deficit in shape discrimination or even colour discrimination is a defect in sensory processing and therefore does not constitute an agnosia. Mr S, a patient studied by Efron (1968), had developed cortical blindness following carbon monoxide poisoning. His symptoms included an inability to identify pictures, objects and people. Efron attributed these deficits to one of shape discrimination (this patient also had more formal shape discrimination difficulties, such as being unable to differentiate a square from a rectangle).

This notion is controversial, because there are some authors (e.g. Humphreys and Riddoch 1987a) who argue that agnosia does represent the inability to perceive form and have termed the inability to discriminate between shapes, ‘shape agnosia’. They describe the deficits in patients who misperceive foreshortened or ambiguously presented objects as showing transformational agnosia, a disorder considered in the section below on theories of agnosia. They also propose a third, distinct type of agnosia that describes an inability to integrate elements of a stimulus to create a recognizable whole. This they describe as integrative agnosia, a disorder exhibited by their patient, HJA (Humphreys and Riddoch 1987a, b).

Integrative agnosia: the case of HJA

Patient HJA was a businessman who had suffered a bilateral stroke. He appeared to show some visual deficits, although his ability to discriminate line length and position were normal. He is able to copy drawings, but he is not an associative agnostic. Humphreys and Riddoch have described HJA's case in some detail, especially his painstaking process of drawing (see Figure 6.1). In one instance, he took six hours to complete a drawing he was then unable to name. The unusual feature of HJA's deficit appears to be the inability to bring together elements of a stimulus into a meaningful unit. One or two minor elements of an object will be used as a basis for attempting to identify the object. Humphreys and Riddoch chose the expression 'integrative agnosia' to describe this phenomenon as a means of distinguishing it from another disorder, simultanagnosia, which is similar but has a more precise symptomatology.

The mechanism underlying HJA's disorder is unclear, but Humphreys and Riddoch have suggested that one of two processes necessary for visual processing is defective. They argue that visual perception involves (1) the establishment of the global form of a stimulus and (2) a process whereby individual features of a stimulus are perceived and are 'bound' together. HJA's problem appears to be an inability to appreciate 'integrative local grouping cues'. The distinction between global and local processing is supported by a small number of cases in the literature. For example, Butter and Trobe's patient can name globally processed stimuli such as silhouettes better than he does stimuli that feature many local visual cues, such as line drawings (Butter and Trobe 1994). Grailet *et al.*'s patient, HG, also exhibits symptoms similar to those of HJA (Grailet *et al.* 1990).

Figure 6.1

An example of one of HJA's elaborate drawings and line drawings of simple objects. HJA is unable to name either (from Humphreys and Riddoch 1987a)



Farah's classification of apperceptive visual agnosia

In addition to the distinct disorders outlined by other authors, Farah (1990) has argued that apperceptive agnosia can be further subdivided into four categories, which she describes as narrow apperceptive agnosia, dorsal simultanagnosia, ventral simultanagnosia and perceptual categorization deficit.

Narrow apperceptive agnosia refers to the inability to recognize, match, copy or discriminate between elementary visual forms despite adequate visual function, whereas dorsal simultanagnosia describes an inability to appreciate a whole stimulus despite adequate recognition of its parts (Wolpert 1924). However, whether subjects actually do recognize these parts individually is open to question. Luria (1959) defined the disorder as an inability to see or attend to more than one object simultaneously. The locus of damage in most patients is bilateral, affecting the parieto-occipital area (especially the superior occipital and the inferior parietal lobes). The underlying deficit appears to be a failure to undertake feature-by-feature analysis of stimuli. The disorder is similar to Balint's syndrome, in which patients with bilateral parietal damage have paralysis of fixation, difficulty in viewing objects voluntarily in peripheral vision and an inability to respond to visual stimuli manually. A patient with Balint's syndrome might focus quite narrowly on the tip of a cigarette in his or her mouth and be unable to see a match offered a short distance away.

Ventral simultanagnosia describes a condition that is not as severe as the dorsal version: patients can negotiate the environment and can perform tasks such as counting dots significantly better than patients with the dorsal form. The locus of damage appears to be the left occipito-temporal junction, although it is debatable whether this is a separate disorder or whether it simply differs in degree from dorsal simultanagnosia.

Farah's final category, perceptual categorization deficit, describes an impairment in experimentally induced recognition with apparently unimpaired real-life recognition. That is, in experiments, patients show recognition impairment, but this impairment does not affect their daily life. The best known of these experiments requires the subject to identify several two- and three-dimensional objects placed at various angles (De Renzi *et al.* 1969; Warrington and James 1986). Patients normally have right-sided parietal lesions (De Renzi *et al.* 1969), although impairments have been noted following right temporal lobe injury (Milner 1958).

In summary, apperceptive agnosia is probably the most controversial agnosia because its existence as a distinct disorder not involving underlying visual disturbance has been challenged (Bay 1953). For example, some have argued that the disorder is a combination of visual sensory disturbance, ocular fixation problems, inattention and dementia (Bender and Feldman 1972). Others have argued that the precise anatomical basis for this disorder is virtually impossible to determine because of the variability in attention, memory, perception and oculomotor behaviour seen in these patients (Bauer 1993). Despite these objections, the term continues to be used. However, an awareness of the controversy surrounding its use is important.

Associative visual agnosia

Patients exhibiting associative visual agnosia are also characterized by poor object recognition, but this deficit does not involve faulty perception. Instead, the patient appears to have problems making meaningful associations to stimuli presented visually. The disorder is usually modality-specific in that patients are able to match objects with those presented

in a different sensory modality. They are also able to point at objects named by the examiner. There appear to be degrees of severity associated with the disorder. For example, identification of line drawings is more difficult than identification of real-life objects and pictures of objects, while pictures are more difficult to identify than real-life objects. In general, however, the more complex the stimulus, the greater the number of semantic errors that the associative agnosic patient makes.

An unusual example of associative visual agnosia was reported by Rubens and Benson (1971). Their patient was a physician with superior verbal skills but impaired visual object identification. He was able to identify objects by touch, but when asked to identify his stethoscope visually he would reply that it was a 'long cord with a round thing at the end'. He could copy drawings and draw well (a characteristic of patients with this disorder), but he identified his drawings incorrectly. Often, patients are slow at the copying task and perform the exercise painstakingly, taking time over small details and features, as Humphreys and Riddoch's patient, HJA, has shown.

The disorder is associated with a right homonymous hemianopia usually resulting from posterior, left hemisphere lesions (Warrington 1985; Geschwind 1965), bilateral occipital lobe lesions (Alexander and Albert 1983) or, it has been reported, right occipital lesions (Levine 1978). The variability in the locus of these lesions might explain the variability of symptoms seen in associative visual agnosia. Lissauer's original case presented lesions of the left hemisphere at the occipital-temporal junction (Lissauer 1890). Hecaen and his colleagues have also reported left occipital lobe lesions (Hecaen and Ajuriaguerra 1956; Hecaen *et al.* 1974), as have McCarthy and Warrington (1986) using MRI in one case study. Posterior left hemisphere lesions appear to be reliably associated with this deficit (Warrington and Taylor 1973).

Associative agnosia is rare and is sometimes seen in combination with other agnosias (such as the inability to identify faces or colours), but its existence has been challenged (Teuber 1965). Hecaen and Angelergues (1963), for example, found that only four patients out of 415 presented this deficit. Patients may not be completely unable to assign meaning to objects because they are able to assign objects to a superordinate class such as mammal, insect or bird (McCarthy and Warrington 1986; Bub *et al.* 1988). There is also the potential difficulty of ruling out the presence of any perceptual deficits in these patients. It is also possible that patients showing this type of agnosia may in fact be exhibiting optic aphasia.

Optic aphasia

Optic aphasia is a disorder in which the naming, but not recognition, of visual stimuli is impaired. The disorder is different from anomia, the inability to name objects, because correct identification is possible in other sensory modalities. The earliest case of optic aphasia was reported by Freund (1889), whose patient suffered a right homonymous hemianopia owing to a parieto-occipital tumour. However, the relative independence of these two disorders, associative agnosia and optic aphasia, has been questioned. It is possible that optic aphasia is a milder form of associative agnosia or that the types of impairment seen in patients fall at some point along a continuum from associative agnosia to optic aphasia. De Renzi and Saetti (1997), for example, argue that both disorders reflect an impaired ability to access structured representations in the semantic, left hemisphere. The disorders differ in the degree of semantic compensation that the right hemisphere provides. The right hemisphere's semantic capacity therefore plays a significant role in the appearance of these disorders, according to De Renzi and Saetti's hypothesis.

Colour agnosia

Colour agnosia refers to an inability to name colours despite the ability to discriminate between them. Patients may be unable to sort differently coloured patches into groups of the same colour or may be unable to colour in pictures appropriately (Sittig 1921; De Renzi and Spinnler 1967). Pointing to a colour named by the examiner is not possible; nor is naming the colour that the examiner points to. Three colour agnosia syndromes include central achromatopsia (dyschromatopsia), colour anomia and specific-colour aphasia.

Central achromatopsia (Green and Lessell 1977) involves a loss of colour vision owing to a lesion to the visual system pathways (the optic nerve, the optic chiasm or both), although it can occur with unilateral inferior occipital lobe lesions. Oddly, this damage can affect one colour more than another. Patients commonly observe that the world is drained of colour and is either black and white, grainy, or grey. However, although unable to identify colours, patients can perform verbal tasks that are colour-related (e.g. answer correctly when asked what is the colour of blood). Damage to the lingual and fusiform gyri has been implicated in the disorder. It is possible that these regions represent the area in humans that corresponds to that in rhesus monkeys responsible for responding to wave-lengths of light (Damasio *et al.* 1980b).

Colour anomia is the literal inability to name colours despite being able to answer verbal questions about colour. Finally, specific-colour aphasia describes a condition in which even verbal questions about colour cannot be answered.

Theories of visual agnosia

The models developed to explain visual agnosia tend to fall into distinct camps. For example, Bauer (1993) lists four such models: stage models, disconnection models, computational models and cognitive neuropsychological models.

An example of a stage model is that of Lissauer (1880), who proposed that recognition comprised two stages of processing: apperception and association. Disconnection models, such as those of Geschwind (1965), argue that agnosia results from a disconnection between two processes, such as visual and verbal processes.

Computational models such as Marr's (1982) suggest that the variation in the perceptual world with which we are presented every day is made possible by three types of representation: a primal sketch, a viewer-centred or $2\frac{1}{2}$ -D sketch, and an object-centred 3-D sketch. The first representation does not depend on an individual's point of view (it is viewpoint-independent); however, the second is viewer-centred and therefore viewer-dependent. An extension of this computational model to include neurology has been proposed by A. Damasio (1989). He argues that the varieties of perceptual experience stimulate representative neural areas corresponding to each type of experience. The features of the object are then combined to form a 'convergence zone', where the whole can be constructed. Recognition, the model argues, depends on the activation of the neural pattern that defines a particular object.

Finally, cognitive neuropsychological models take a slightly different view and are inclined to regard any neuropsychological disorder in terms of components or modules. These models view the various cognitive and emotional operations as dissociable and are reviewed in the following sections.

Apperceptive agnosia

Much of the controversy in visual agnosia research is generated by two problems. (1) Are apperceptive and associative agnosias dissociable? (2) Are visual, sensory deficits necessary or unnecessary for a diagnosis of agnosia? Lissauer's model clearly separates the two processes of apperception and association. Warrington also suggests a dichotomy in which perceptual classification is separate from semantic classification (and perhaps reflects Lissauer's dichotomy in a more specific, neuropsychologically driven way). As we have already seen, Warrington argues strongly for the absence of lower-level visual deficits before a diagnosis of agnosia can be made, describing such disorders involving lower-level disruption as pseudoagnosia. However, Humphreys and Riddoch dismiss the notion of pseudoagnosia, arguing that shape discrimination deficits do reflect recognition difficulties and not specifically sensory ones.

One computational theory of apperceptive agnosia that has gained some favour in those quarters represented by Warrington is based on the concept of axis transformation (Marr 1982). Marr's theory suggests that a three-dimensional representation of an object is obtained by determining the object's minor and major axes. Seeing a tennis racquet from the side, for example, supplies information from the major axis (its length), which we can then use to make inferences about other aspects of the racquet (such as the width of the handle). A task in which the subject is required to identify objects from unusual perspectives is difficult, Marr argued, because a major axis has been obscured or foreshortened. Based on this reasoning, Humphreys and Riddoch (1987a) attributed apperceptive agnosia to a deficit in axis transformation and, as we saw earlier, termed it 'transformational agnosia'.

An alternative theory, the distinctive-features model of object recognition (Warrington and James 1986), suggests that sets of distinctive features identify an object's structure. The determinants of object recognition, therefore, would not be axis rotation but how many features were made available at a specific angle. One objection to the theory is that object perception deficits are not homogeneous, i.e. there seem to be dissociations between classes of stimuli (McCarthy and Warrington 1990). Unless the model suggests a stimulus-specific, feature-specific deficit, it cannot account for these dissociations.

A final model suggested by Rudge and Warrington (1990) is based on data from patients with splenium lesions, who perform poorly on the unusual views task but are normal at recognizing perceptually simple pictures; i.e. there is no visual agnosia. This 'optional resource' hypothesis states that information may be processed in parallel: object meaning is derived from both visual information processing that is sensory in nature and the functioning of the right hemisphere and splenium, but only if a task requires the analysis of an ambiguous or difficult object structure.

Associative agnosia

One theory of associative agnosia argues that one system is responsible for mediating the meaning of all stimuli. This is called the shared-systems theory. Agnosia is therefore a problem of connecting the output of perceptual analysis with the patient's general store of knowledge. Riddoch *et al.* (1988) suggest that problems occur because of a breakdown in the transmission of information from the perceptual to semantic systems; i.e. there is a disconnection. This theory does not appear to account fully for the disorder, however, because the literature features great variability in symptoms.

For example, a second approach, the independent-systems theory, suggests that processes such as visual object recognition are independent of other processes such as those required for speech production or comprehension of words. Evidence for this approach comes from studies in which impairments in visual processing do not accompany verbal impairments, and *vice versa* (McCarthy and Warrington 1988). What the theory suggests is a form of modularity in which some psychological processes are dissociable and independent of each other (Fodor 1983). Further evidence for this model comes from data showing that an ability to recognize common objects may be impaired, but the ability to recognize complex shapes is not. Furthermore, based on an extensive review of the literature reporting cases of alexia (A), visual object agnosia (VOA) and prosopagnosia (P, face recognition impairment), Farah (1990, 1991) has suggested that object recognition is subserved by two independent but parallel processes. One process concerns the perception of the whole pattern of stimuli; the other concerns the perception of constituent elements of an object. Farah drew this conclusion from literature that showed that although all of the following combinations were possible:

A, VOA and P

A and VOA

VOA and P

no case of alexia with face recognition impairment but without visual object agnosia had been reported. This suggested two systems: one that recognized wholes (e.g. faces) and another that recognized constituents (e.g. words). Visual object recognition depended on both processes. The logical extension of this thinking dictates that the apperceptive/associative distinction becomes unnecessary. However, Humphreys and Riddoch (1993) have argued against such a view, citing evidence from patients who are unable to recognize objects but are able to make decisions based on the properties of objects. That said, their patient HJA, although poor at face recognition, was better at identifying silhouettes than line drawings, which perhaps indicates the operation of some 'holistic' process.

Category-specific visual agnosia

Some agnosic patients appear to be poorer at recognizing some visual stimuli than others (Newcombe *et al.* 1994). In neuropsychology, one category of stimuli – faces – stands out, and this is considered in the next section. However, other dissociations in recognition have been reported. Warrington and Shallice's patient, JBR, for example, is apparently unable to name living things or musical instruments but can name non-living things and parts of the body (Warrington and Shallice 1984). Warrington's studies show that patients with specific brain injury show severe and consistent impairment in the naming of living things (*ibid.*). This dissociation was found whether the stimuli in the studies were in verbal or non-verbal form. On the basis of these findings, Warrington and Shallice argued that the distinction could be explained in terms of the perception of different features of these objects. Living things would be perceived in terms of their individual attributes, such as shape, colour and size, whereas non-living things are perceived in terms of the function they seem to carry out. The living thing impairment was therefore a problem in perceiving individual sensory attributes. Does this evidence suggest that different regions of the brain process different categories of stimulus?

Martin and his colleagues compared brain activation in healthy individuals as they named drawings of tools or animals (Martin *et al.* 1996). They found that although both tasks bilaterally activated the ventral temporal lobes and Broca's area, the naming only of animals activated the left medial occipital lobe. The naming of tools only was associated with activation of the left premotor area and middle temporal gyrus, areas that are known to be activated during hand movement and generation of 'action' words, respectively (see Figure 6.2).

In a later fMRI study, viewing and naming tools selectively activated the left posterior parietal cortex (BA 40), whereas viewing and naming animals, faces and houses did not (Chao and Martin 2000). These findings suggest that an object's identity is processed by different regions of the brain, depending on the meaning assigned to that object, and might go some way towards explaining the dissociations seen in associative agnosia. Or do they?

Warrington and Shallice's study was based on four patients with herpes simplex encephalitis, a degenerative brain disease that obviously warrants a degree of caution in interpreting their results. However, some psychologists have argued that brain injury studies do not show differences in the perception of categories of object but between the ways in which these two different types of stimulus are presented. It is possible that these dissociations in neuropsychological patients are not the result of genuine inability to recognize specific categories of object but are the consequence of stimulus artefact. The stimuli used in experiments in which dissociations have been reported may not be entirely appropriate. Parkin and Stewart (1993), for example, have suggested that it is more difficult to

Figure 6.2

Areas of brain activation observed during the viewing of tools (darker areas) and animals (lighter areas), using fMRI (from Martin and Chao 2001)

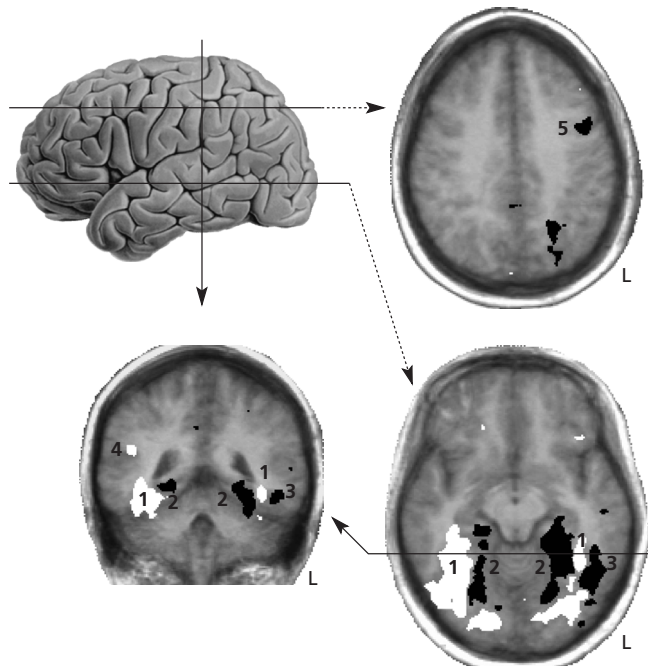

recognize drawings of animate than of inanimate objects. An inanimate object such as a cup is a lot less detailed than an animate object such as a fly. The dissociation seen in agnostic patients may therefore be due to the complexity and/or familiarity of the perceived stimulus. Stewart *et al.* (1992) have suggested that when these artefacts are limited, these dissociations disappear. In similar vein, some written words may be more familiar than drawings of the objects they are meant to represent. In addition, the usual picture database used to examine recognition itself contains fewer familiar living than non-living things. The dissociation between impaired animate and inanimate object recognition therefore becomes questionable, because the results can be attributed to factors unrelated to stimulus category. Even JBR's deficit disappears when all stimuli are made equally familiar. However, the issue continues to be controversial. Sheridan and Humphreys (1993), for example, have shown that patients show such dissociations even under well-controlled conditions. It also appears that the manipulability of an object is important for the ease of its identification – when the familiarity of an object is not controlled, more manipulable objects have been found to be identified more quickly; when familiarity is controlled, they are identified more slowly (Filliter *et al.* 2005).

At a more cellular level, Kreiman *et al.* (2000b) recorded activity in various regions of the temporal lobe in eleven epileptic patients as the participants viewed images of unknown faces depicting emotion, objects, spatial layouts, drawings and photographs of famous people, foods, and abstract shapes. They found that the three regions they studied fired selectively to specific categories of object: the entorhinal cortex responded selectively to pictures of animals, the anterior hippocampus to images of famous people (but not emotional faces) and the hippocampus in general to layouts, houses and interiors (a finding consistent with the proposed classical role for the hippocampus in spatial navigation).

The visual features versus function interpretation has been challenged. Caramazza and Shelton (1998), for example, suggest a much stronger 'specificity model' of brain function, arguing that different regions of the brain mediate different 'domains of knowledge'. Others have drawn attention to the interconnectedness of features in living stimuli (Moss *et al.* 1998). For example, an animal may have features such as eyes, ears and legs, indicating that it can see, hear and walk and that these features are processed in an interconnected way when we see them; non-living things have fewer interconnected features. Current evidence suggests that brain regions may mediate specific semantic categories, rather than the interconnectedness of features of stimuli or the visual or functional nature of stimuli (Gainotti 2000). The brain imaging studies described here provide strong support for such a view. One reason for this may be the heterogeneity of objects that fall into the categories of living and non-living things: brain injury studies usually find that a naming deficit is specific to a certain type of living or non-living thing, such as plants and animals, rather than animate and inanimate objects in general. The naming deficit for living things can also extend to non-living things such as food or musical instruments (*ibid.*). In support of the process, rather than the stimulus, explanation, Rogers *et al.* (2005) used PET to measure brain activation while participants categorized photographs of animals or vehicles at an intermediate level of specificity (cars or dogs, for example) or a more explicit level of specificity (BMW's or Labradors). Whereas animal-specific activation was observed in the lateral posterior fusiform gyri when stimuli were categorized at the intermediate level, activation was observed in this area to both types of stimulus when categorization was more explicit. This suggests that these regions are active when we need to distinguish between stimuli that are visually or semantically very similar.

Prosopagnosia

The best-known and most well-documented category-specific recognition disorder is prosopagnosia. In 1947, Bodamer reported three patients who had difficulty recognizing faces but who could recognize objects normally (Bodamer 1947). He termed this phenomenon 'prosopagnosia' ('loss of knowledge of faces') and regarded it as a distinct neurological deficit. Later, Hecaen and Angelergues (1962) reported twenty-two cases of prosopagnosia who failed to recognize the faces of even old acquaintances (in some cases, even themselves). One patient remarked when looking at his wedding photograph: 'Two people . . . one of them could be my wife because of the silhouette . . . if it is my wife, the other person could be me'. Despite the inability to identify faces, patients are able to identify individuals by their voice, clothing or marks on other parts of the body. Sometimes, faces are described as having a distorted, warped or flat appearance. However, patients can recognize a face as being a face and can discriminate between faces. The problem lies in being unable to identify individual faces. One of the more famous examples of prosopagnosia was reported by Sacks (1985). Dr P, 'the man who mistook his wife for a hat', had severe prosopagnosia. According to Sacks, 'he saw faces when there were no faces to see: genially, Magoo-like, when in the street, he might pat the heads of water-hydrants and parking meters, taking these to be the heads of children; he would amiably address carved knobs on the furniture, and be astounded when they did not answer'. There are many other unusual examples of prosopagnosics' behaviour, such as the man who had wondered why a diner in the same restaurant had been staring at him intently for some time only to discover from the waiter that he was staring at his own reflection in the mirror (Pallis 1955).

Under laboratory conditions, prosopagnosia is demonstrated by administering a number of facial recognition tests. One is the same/different task and requires patients to determine whether two photographs are of the same individual when the pairs could be two different views of the same person, or two different but similar-looking people. Another task might require the patient to match a frontal view of a person with one of six stimuli that may be a three-quarter view of the same face or the same face under different lighting conditions (Benton and Van Allen 1968). A slightly more unusual but sensitive test requires subjects to rank groups of four faces by age (De Renzi *et al.* 1989). However, there is evidence that prosopagnosic patients can distinguish between faces based on the criteria of expression, age and sex (Tranel *et al.* 1988).

There is also evidence to suggest that some patients might be sensitive to particular features of the face. Gloning and Quatember (1966), for example, found that prosopagnosic patients were worse at matching eyes to whole pictures than they were at matching mouths, although the reasons for this are unclear. The accurate perception of facial expression may be impaired (De Kosky *et al.* 1980), but this is complicated by the inability to identify emotional facial expression (Etkoff 1984).

Sometimes, patients may have difficulty recognizing famous people (Warrington and James 1967) or very familiar people like spouses (De Renzi 1986a, b). One patient, a 73-year-old public notary studied by De Renzi, once remarked to his wife, 'Are you . . .? I guess you are my wife because there are no other women at home, but I want to be reassured'. His face perception evaluated on sensitive tests was normal.

In an interesting study by Bruyer *et al.* (1983), one patient had difficulty recognizing all but very familiar faces. When taught to associate names with the faces, he was able to do so but he was much slower at associating the names when they were false ones, which suggests some unconscious knowledge of the faces' names. To date, prosopagnosia has never occurred in pure form, i.e. without associated perceptual deficits. The box describes some of the reported case studies of impaired familiar face recognition.

Prosopagnosia: the case of Adam and others

Patients with prosopagnosia are unable to recognize famous faces, familiar people such as spouses or even themselves. One patient studied by Tippett *et al.* (2000) was unable to recognize hospital staff or some members of his family after surgery to his right temporal lobe. The patient was a man of average to high intelligence who, at the age of 22, had been in a motorcycle accident. Six years later, the temporal cortex was removed to alleviate his epilepsy. It became apparent after the surgery that he was unable to identify hospital staff or even his daughter and could identify his wife only by her hair or gait. However, he was able to identify some members of his family and some famous faces. He also appeared to show a selective deficit in the ability to learn new faces. When given a test requiring him to identify the faces of people who became famous prior to 1982 (the year of the accident) and those faces who became famous after that year, he could identify 20/23 of faces that were famous before 1982 but only 8/17 of those post 1982. His learning of other visual stimuli was preserved after injury, suggesting that the damage affected the learning of face stimuli only.

Another case study has highlighted how early brain damage can permanently affect the perception of faces (Farah *et al.* 2000). Farah *et al.*'s patient was a 16-year-old boy called Adam who had had a normal birth but had developed streptococcal meningitis when one day old. At 6 years old, Adam was found to have lesions in the occipital and temporal cortices in both hemispheres. Although he showed no object agnosia, he did show prosopagnosic symptoms. At meetings with doctors and nurses, he waited until he was spoken to because he could recognize voices but not faces. He could identify features of faces well, a typical prosopagnosic symptom. But putting these features together to form a meaningful label was almost impossible. When he was asked to identify ten photographs of people from *Baywatch*, ten famous people he knew of and twenty photographs of people he did not know, he was unable to identify one of them. Yet he was able to match faces when given a task that required him to match a face with the same face presented in a series of faces, so long as the angle of the face and the lighting conditions were adequate. In a conceptually similar study of seven patients with developmental prosopagnosia, Duchaine and Nakayama (2005) found that these participants were poorer at recognizing faces in an experiment in which they were presented with new and previously seen objects and faces after initial acquisition. Four out of seven were poorer at recognizing faces than objects.

Explaining prosopagnosic deficits presents neuropsychology with one of its most interesting challenges. Is it a form of object visual agnosia or is it a form that is specific to faces? Or perhaps it is an inability to identify individuality in a class of objects? This last question has been addressed in a small number of studies in which prosopagnosics were unable to identify specific chairs (Faust 1955) or cars (Lhermitte and Pillon 1975). Bornstein *et al.* (1969) reported two patients, one a farmer, the other a birdwatcher, who were unable to identify specific cows and birds, respectively. The inability to name faces has led to the suggestion that prosopagnosia may be an impairment of memory. Impaired familiar face perception often indicates amnesia, for example, and prosopagnosics are poor at learning new faces (as are amnesiacs). This relationship is not reciprocal, however. For example, it is rare for an amnesiac to be prosopagnosic. Alternatively, it has been suggested that a visual categorization defect and a material-specific defect are nec-

essary for prosopagnosia to occur (Damasio *et al.* 1982). What Damasio and his colleagues suggest is that a ‘visual trigger’ cannot prompt the retrieval of ‘multimodal memories’, although the context of learning has been processed. This is known because individuals can be identified by voice or clothing. Some specific hypotheses about prosopagnosia and face recognition are considered in the discussion point.

Locus of damage

The locus of brain damage in prosopagnosia tends to be right hemisphere-based, although the disorder does occur with bilateral damage to white matter and cortex in the occipito-temporal gyrus. However, cases have been reported where prosopagnosia was found without lesion to this junction (Damasio *et al.* 1982). These authors also report bilateral damage associated with the disorder, suggesting that unilateral right hemisphere lesions may be necessary but not sufficient for prosopagnosia to occur. Unilateral right hemisphere lesions are common (De Renzi *et al.* 1994; Landis *et al.* 1986). Studies of perception and recognition of facial expression have also associated deficits with unilateral right hemisphere damage (Bowers *et al.* 1985). De Renzi *et al.* (1994), in a review of the literature, noted twenty-seven cases where neuroimaging data demonstrated right hemisphere damage with prosopagnosia. Lesions in the parahippocampal gyrus and lingual and fusiform gyri are also considered necessary for prosopagnosia (Meadows 1974; De Renzi 1986a), as is damage to the splenium (Benton 1990).

Discussion point: where does the intact brain ‘see’ faces?

Faces have always occupied a special place in neuropsychology (Farah *et al.* 1998). Even babies 30 minutes of age are adept at orienting towards faces. Some authors argue that an infant’s visual system is set up to process stimuli with low spatial frequency – their visual acuity is low – and that more specialized visual processing such as configural processing follows. This development continues until around the age of 10 (LeGrand *et al.* 2001). LeGrand *et al.* showed that if the system is dysfunctional even at two months of age – it cannot process certain types of information – this can lead to permanent deficits in the ability to make judgements about the configuration of features in faces.

Face recognition is important to us. It helps us to identify friends, family and acquaintances, and it can make us attracted to others. The face can carry significant social information; signals from it can cue responses from us and change our behaviour. We might comfort someone who looks sad and is crying; we may smile when another person smiles; we may avoid or confront those who look angry; we may be offended at another’s rolling of the eyes or help those with a furrowed brow. All of these signals are social ones, helping us to interpret how another person is behaving or feeling. And the vehicle conveying these signals is the face.

Much of the recent neuropsychological work on face recognition has exploited neuroimaging techniques in order to determine whether different regions of the human brain respond to faces selectively. One controversy in the area surrounds whether such selective activation is specific to faces or to some other perceptual aspect of faces, such as whether they appear in greyscale or in two-tone.

In one experiment, participants observed inverted or upright faces in greyscale; in a second experiment, participants observed upright or inverted two-tone faces (Kanwisher *et al.* 1998). One specific brain region – the human fusiform face area (HFFA) – was singled out for analysis; the location of this can be found in Figure 6.3.

Both the upright and inverted greyscale faces activated the HFFA, but the inverted faces produced less activation. However, inverted two-tone faces were associated with significantly reduced brain activation. The results suggest that the HFFA does not respond specifically to low-level features of faces (or the inverted and upright two-tone faces would have produced similar activation) but does respond to face stimuli. However, the authors acknowledge that this may not be the only brain region specialized for face processing.

However, neuroimaging data make this region a strong contender for the role of the brain's primary face processor. The HFFA is activated selectively by the perceptual analysis of faces, whereas different regions are implicated in famous name processing, relative to common names (Gorno-Tempini *et al.* 1998). The right HFFA is also active during the memorization (rather than passive watching) of unfamiliar faces, which suggests the region's involvement in remembering faces as well as processing them (Kuskowski and Pardo 1999).

Figure 6.3

The locations of (a) the parahippocampal place area and (b) the fusiform gyrus or human face area

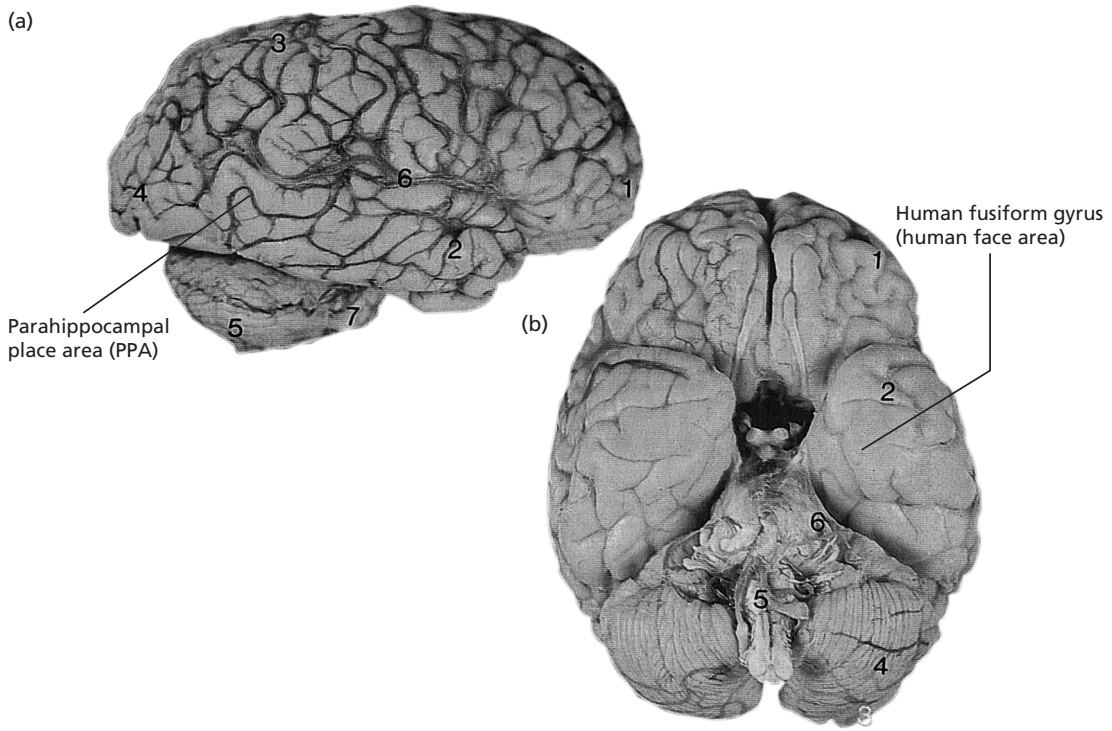

To determine whether the HFFA really did just respond to faces and not to animate objects in general, Kanwisher *et al.* (1999) asked participants to view various pictorial stimuli such as human heads, animal heads, human bodies and animal bodies, in an fMRI study. The strongest response in the HFFA was found during face perception, followed by whole humans and animal heads, which suggests that the area is more involved in face – than other object – perception.

However, the notion that we have a specialized brain region for processing faces may be too simplistic. For example, it has been argued that the HFFA, rather than being specialized for recognizing faces, is responsible for distinguishing between members of a homogeneous class of objects (Tarr and Cheng 2003). These objects could be faces or any other coherent class of stimulus. An extension to this argument suggests that the HFFA is active when it distinguishes between members of object classes that we are expert in identifying. Because we are very familiar with faces, and expert at recognizing them, the HFFA is active when we view them. However, this argument also suggests that expert identifiers should activate the HFFA when they view any objects they are expert in recognizing (not just faces). This is called the individuation hypothesis; the proposal that there are specific brain regions responsible for the selective recognition of faces is called the face-specificity hypothesis.

To test these various hypotheses, Rhodes *et al.* (2004) set up two experiments in which people were either trained or were not trained to recognize *Lepidoptera* (moths and butterflies). Brain activation was monitored using fMRI while participants viewed faces and *Lepidoptera*. In the second experiment, experts in identifying moths and butterflies passively watched examples of the species while brain activity was recorded. If the HFFA is active during expert discrimination, then it should be just as active during face perception and *Lepidoptera* perception.

The authors found no support for this hypothesis. In the first experiment, greater HFFA activation was observed when people watched faces than *Lepidoptera*, regardless of whether people had been trained to recognize examples of the species. Scans showing this activation are shown in Figure 6.4.

In the second experiment, activation was greater in the HFFA when the butterfly experts watched faces than *Lepidoptera*. There was no overlap in the areas activated by faces and moths and butterflies, which suggests that the HFFA contains neurons that allow ‘individuation’ of (i.e. discrimination between) faces.

Figure 6.4

Areas of activation seen in the experts and non-experts when viewing *Lepidoptera* and familiar faces (from Rhodes *et al.* 2004. © 2004 by the Massachusetts Institute of Technology)

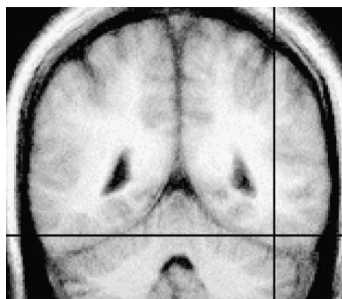

LO untrained novices

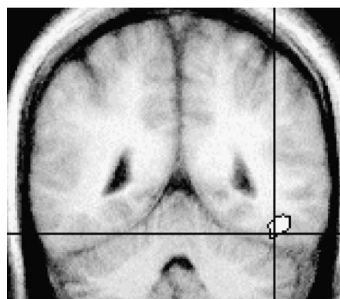

LO experts

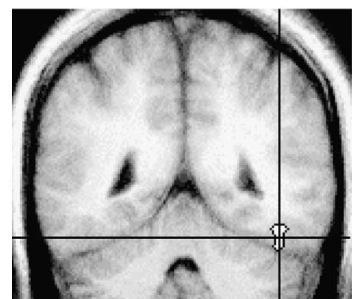

FO experts

Covert recognition in prosopagnosia

Despite the apparent inability of prosopagnosics to identify faces, there is evidence that some patients may be able to do this covertly. For example, Bauer (1984) measured galvanic skin response (GSR) while his patient, LF, viewed a familiar face then listened to five names read aloud. When the name associated with the face was read, there was a greater change in galvanic skin response than when the other names were heard. Yet when asked to identify the name associated with the picture, performance was at chance level. Bauer's explanation for this phenomenon was that overt recognition and orienting to emotional stimuli involve two pathways: a ventral route, which allows overt recognition but which is damaged in prosopagnosia, and a dorsal route, which is spared and allows emotional significance to be attached to faces.

In a conceptually simple experiment, Tranel and Damasio (1985) presented a prosopagnosic patient with a series of famous and unfamiliar faces. GSR changed significantly during exposure to the familiar faces. One of their patients also demonstrated an inability to recognize faces after illness, what Tranel and Damasio called 'anterograde prosopagnosia'. What appears to be lost is not complete recognition but an awareness of recognition (Young 1994a). Two further recent single-case studies, using different experimental paradigms, have also shown that some prosopagnosic patients show evidence of covert face recognition (Bobes *et al.* 2003; Sperber and Spinnler 2003) but that covert and overt face recognition may rely on the same mechanism. FE, a 63-year-old prosopagnosic patient, performed at chance levels when asked if two sequentially presented pictures showed the same or a different person (Bobes *et al.* 2003). However, when his ERP indices were examined, latency was found to be shorter during conditions where the stimuli represented the same person, suggesting that although no overt recognition occurred, the psychophysiological data indicated that a degree of covert recognition had.

Burton *et al.* (1991) have suggested that the problem seen in prosopagnosia is one of disconnection. In their model, the link between facial recognition units (FRUs), which code the visual aspects of faces, and personal identification nodes (PINs), which code the person-specific aspects of faces such as their familiarity, are damaged. An alternative view proposes that there are different routes for recognition and that these converge on information that is held about the individual (Farah *et al.* 1993). These routes include those for factors such as names and faces. Familiarity with the stimulus can be signalled by each of these routes separately. When the 'module' responsible for visual representation of faces is damaged, this is caused by disruption to the computational process that allows these representations to be formed. In prosopagnosia, the personal information is so degraded that only covert recognition is available.

The Bobes *et al.* study is more likely to be explained by the Burton *et al.* model than by the Farah *et al.* model, because the task in the Bobes *et al.* study is difficult, even when faces were represented simultaneously (Bruce *et al.* 1999). Good visual representation is therefore needed to complete it successfully. The Burton model explains the Bobes findings by assuming that visual representation is intact but the damage to the system occurs later in the model, resulting in a disconnection between representation and higher-level knowledge (Schweinberger and Burton 2003; Stone and Valentine 2003).

Amygdala and face processing

Any discussion of the neural substrates of face processing must, for two reasons, include the amygdala. First, damage to this structure has been associated with impaired memory for faces, and second, there are cells in the amygdala that respond selectively to faces in primates (Rolls 1984) and humans (Seeck *et al.* 1993).

However, human data have largely been limited to studies of memory for faces and not of performance over a range of face-processing tasks. Jacobson (1986), in one case, found poor learning of new faces, borderline abnormalities in the matching of unfamiliar faces and impaired recognition of familiar faces (especially in naming faces). Young *et al.*'s study of DR, a 51-year-old woman whose amygdala had been partially but bilaterally removed, reported that she was able to recognize pre-operative, familiar faces but was impaired at naming faces and recognizing faces learned post-operatively (Young *et al.* 1995). Matching unfamiliar faces was unimpaired, but the matching and identification of emotional facial expressions was poor. We will return to the role of the amygdala in face processing in Chapter 10 (Emotion).

Models of face processing

Given the data provided by studies of prosopagnosia, it may be possible to construct a model of face processing that explains which systems mediate which aspects of face perception and recognition. A well-known model is that of Bruce and Young (1986) and

Figure 6.5

Bruce and Young's model of face processing (from Bruce and Young 1986. Reproduced with permission from the British Journal of Psychology © The British Psychological Society)

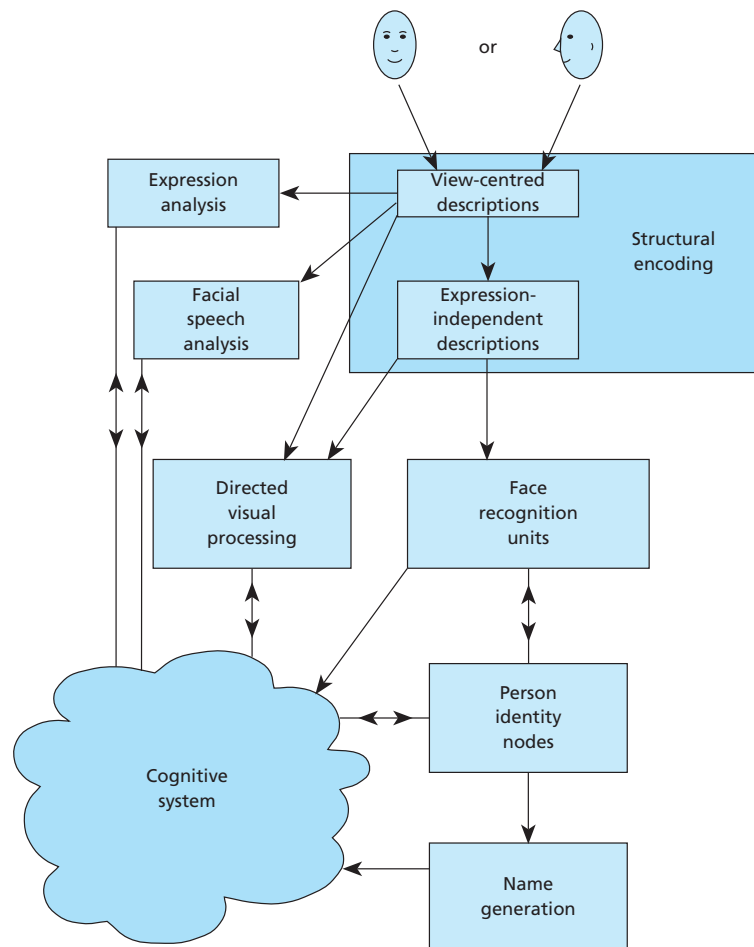

Burton *et al.* (1991). The Bruce and Young model proposes that the processing of facial expressions, the recognition of familiar faces and the matching of unfamiliar faces involve different cognitive abilities (see Figure 6.5), and much debate has focused on whether different mechanisms are needed to identify familiar and unfamiliar faces. A summary of some of the prominent models of face processing can be seen in Figure 6.6.

Facial expression analysis is thought to be ‘dependent on view-centred descriptions created at the structural encoding stage’, familiar face recognition is dependent on access to ‘face recognition units’ via expression-independent descriptions, and unfamiliar face matching is dependent on both view-centred and expression-independent descriptions. Therefore the pathway needed for each function differs. There is some evidence for the model. Patients with facial identity problems, for example, can readily identify facial expression (Tranel *et al.* 1988). Evidence from prosopagnosic patients also lends support to the model (Benton and Van Allen 1968; Warrington and James 1967). The identification of sex and expression is dissociable from identity (LeGal and Bruce 2002).

To explore the possibility that familiar face identification, unfamiliar face matching and expression analysis are independent of each other and, therefore, activate different brain regions, Young and his colleagues studied ex-servicemen who had unilateral missile wound lesions in posterior left and right hemispheres (Young *et al.* 1993). Two tests each of face identification, matching unfamiliar faces and analysing facial expression were used, and accuracy as well as latency (the time taken to complete the tasks) were measured. If the three components of perception studied were independent, the authors

Figure 6.6

A meta-model of face recognition proposed by Schweinberger and Burton (2003) (from Schweinberger and Burton 2003)

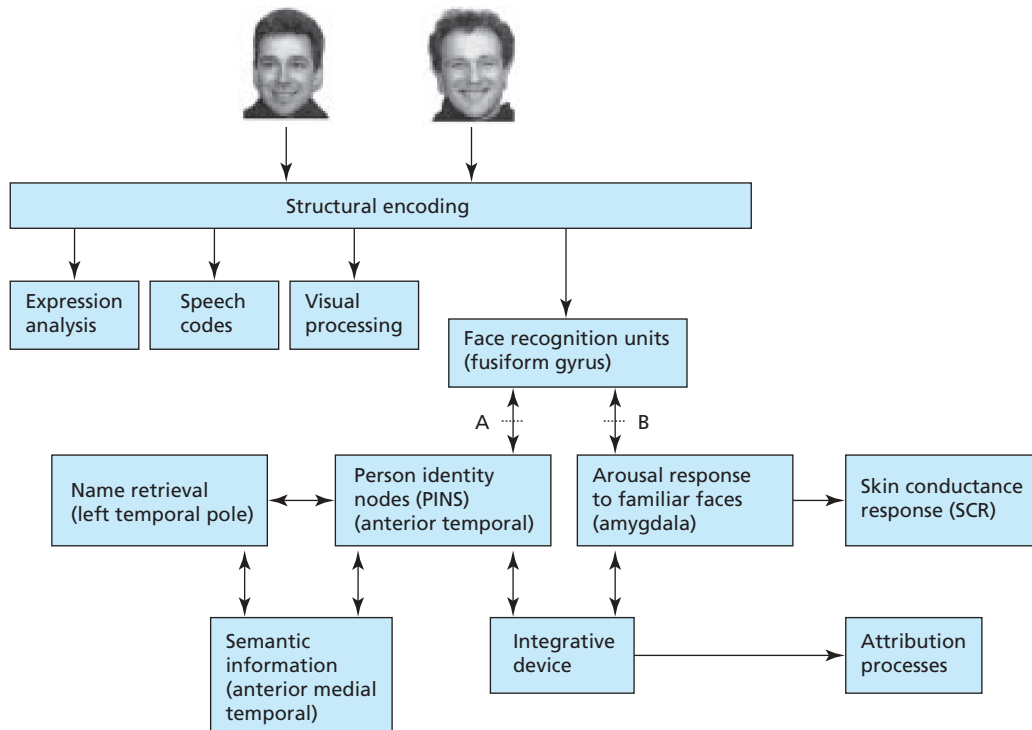

hypothesized, then selective impairment would be expected on both tasks measuring the same function but not on the four others. In fact, there was evidence for selective impairment for all three tasks.

One patient with right hemisphere lesions performed badly at identifying familiar faces only, another was selectively impaired in accuracy when matching unfamiliar faces; and a number of men with left hemisphere lesions had impairments on facial expression analysis only. There was no evidence of selective impairment of identification and unfamiliar face matching when latency data were considered.

Landmark agnosia

Some researchers believe that the face-processing region of the brain, highlighted in those studies reviewed in the last section, has a building or place analogue. That is, there is a part of the extrastriate cortex that is selectively activated during the perception of places or buildings, an area called the parahippocampal place area (so called because these stimuli seem to selectively activate the parahippocampal gyrus). The evidence for the specialization of this region is growing. It began when studies of brain injury showed that some patients with damage to the occipital lobe had difficulty in using features of the environment to find their way along a route (Whiteley and Warrington 1978). The disorder, called 'landmark agnosia', was characterized by an impairment in the perception or recognition of street scenes, landscapes, monuments and buildings (Hecaen *et al.* 1980). What was interesting is that agnosia for faces and objects could occur without agnosia for landmarks (Tohgi *et al.* 1994), suggesting that the functions were dissociable and mediated by a different part of the brain.

To test this hypothesis in a sample of healthy individuals, Aguirre *et al.* (1998) used fMRI to investigate how the brain would respond to photographs of objects, buildings and faces. They found that the buildings and faces activated different regions fairly consistently. When people viewed buildings, a region near the right lingual gyrus was observed; when people viewed faces, the fusiform gyrus region residing near to the 'building area' was observed. To see whether the building effect was due to featural rather than categorical reasons (i.e. to investigate whether the lingual gyrus responded to features of objects in general or to buildings in particular), the researchers asked participants to view two-tone images of buildings and scrambled versions of these and then compared their brain activation with responses to images of another, different object – cars. They found that the right lingual gyrus's response was twice as large when participants viewed buildings than when viewing cars.

Although the findings do not demonstrate that this area is necessary for the perception of buildings, they do suggest that this area might play an important role in the perception of building or building-type objects. The question then is this: if these findings can be replicated, what is the special quality of buildings that makes brain regions selectively activated during their perception? The question is currently unanswered. Aguirre *et al.* suggest that this region may be involved in representing stimuli that are used for orientation; using landmarks such as buildings, for example, helps us to orient ourselves, determine where we are and where we need to go to. A further question then arises: what exactly is a landmark?

Auditory agnosia

Auditory agnosia refers to the inability to recognize or identify sounds despite an intact auditory system. Agnosia may be for general speech and non-speech sounds or may be specific to non-speech sounds. Within each of the two types of disorder there are a number of more specific disorders (Bauer 1993). Into the general category fall auditory sound agnosia, auditory verbal agnosia and a disorder involving both of these. Into the second, narrower category fall pure word deafness (an impairment in the ability to recognize speech sounds) and auditory agnosia (an impairment in the ability to recognize non-speech sounds). There are also related disorders such as cortical deafness, where patients are unaware of any type of sound although their tone threshold is normal, and receptive amusia, the inability to appreciate features of aural music.

Pure word deafness

Pure word deafness, which is also known as auditory agnosia for speech or auditory verbal agnosia, is the inability to comprehend spoken speech despite having unimpaired speech, writing and reading. Comprehension of non-verbal sounds is spared. It is described as 'pure' because the characteristics of aphasia common to that disorder are usually absent. Patients remark that sounds are muffled or sound like a foreign language (Albert and Bear 1974). The neuroanatomical basis of the disorder is thought to involve bilateral, symmetrical corticosubcortical lesions of the anterior temporal gyri, although unilateral subcortical lesions in the temporal cortex of the language-dominant hemisphere also produce similar symptoms. There may also be some specificity within the disorder, with some patients presenting impaired auditory comprehension of abstract but not concrete words (Franklin *et al.* 1994).

Auditory sound agnosia

Auditory sound agnosia, or auditory agnosia for non-speech sounds, is rare and has been divided into two specific types (Vignolo 1969). The first results from right hemisphere lesions and involves a deficit in perceptual discrimination of non-speech sounds. The loci of the damage appear to involve the parietal lobe, specifically the superior temporal and angular gyri, and the inferior and middle frontal cortex and the insula. The second type is associated with left hemisphere lesions and involves a disruption in semantic processing such as mistaking the sound of an object for that of another (e.g. mistaking a man whistling for birdsong, or a train for a car engine).

Receptive amusia

Receptive amusia, or sensory receptive amusia, is found in cases of auditory sound agnosia, most aphasias and pure word deafness. It refers to an inability to discriminate pitch, recognize melodies or hum a tune, despite intact memory and sensory ability. It is one of the more difficult disorders to diagnose, however, because a diagnosis relies on a knowledge of the patients' previous ability to appreciate characteristics of heard music, and this is not always obtainable. A variant of the disorder is congenital amusia – or tone-

deafness, a condition first systematically described in Grant-Allen's (1878) case study of a 30-year-old man. The disorder is described as congenital because the degree of musical instruction does not appear to produce any improvement in the disorder. The disorder is also specific to music – congenitally amusic patients can process and recognize speech sounds, appreciate speech prosody and identify human and environmental noises (Ayotte *et al.* 2002).

Somatosensory agnosia

The final class of agnosias discussed in this chapter are those involving somatosensation and are probably the least well understood of the agnosias. Early classification divided the somatosensory agnosias into amorphognosia (an inability to recognize an object's size or shape), ahylognosia (an inability to determine an object's weight, texture or temperature) and tactile asymboly (an inability to identify objects when amorphognosia and ahylognosia are absent) (Delay 1935). The terms 'tactile agnosia' and 'astereognosis' are the most commonly employed today.

Tactile agnosia describes the inability to identify an object by touch despite having adequate sensory, intellectual and linguistic ability. Astereognosis describes the inability to distinguish three-dimensional forms or to discriminate between objects based on size or shape. Tactile agnosia and astereognosis are sometimes used interchangeably, although they are most likely to be dissociable. When there is an inability to identify objects by touch in the presence of sensory impairment, the disorder is called *steroanaesthesia*.

The neural basis of the disorder is usually damage to the contralateral postcentral gyrus (SI) and hand area of the motor cortex. It has been suggested that unilateral damage to SI causes contralateral impairment, but unilateral damage to SII results in less severe impairments affecting both hands (Corkin 1978). Like most of the agnosias, the reality of the disorder has been questioned, with tactile agnosia being interpreted as a basic somatosensory dysfunction, a modality-specific anomia or a disorder in spatial perception. The first interpretation receives some support from a study in which those patients with CNS and PNS disorders who had somatosensory deficits also had greater tactile object recognition problems when unilateral damage was found in the parietotemporal cortices (Caselli 1991). However, a recent case study indicates that tactile shape perception can be dissociated from tactile spatial ability, shape exploration and perception of length (Reed *et al.* 1996). Reed *et al.*'s patient, EC, had sustained a left inferior parietal infarction involving areas 39, 40, 17, 18 and 36, which affected her ability to identify objects by touch. Despite intact tactile sensation, this patient manifested unilateral tactile agnosia.

Unilateral spatial neglect

The disorder unilateral spatial neglect (often referred to as simply spatial neglect, spatial hemineglect or hemi-inattention) is a failure to report, or respond or attend to, stimuli or events in the hemifield contralateral to a brain injury (usually temporoparietal) despite adequate elementary sensory or motor function (Heilman *et al.* 1994). Visual neglect is a common disorder accompanying stroke. Patients appear to 'see' only half of the world,

and the neglect of stimuli can occur for months and even years after the lesion. A neglect of stimuli on the left following right hemisphere damage (especially in the inferior parietal lobe) is more common, although right neglect following left hemisphere lesion is also observed but is usually not as severe (Vallar 2001; Heilman *et al.* 2003).

The disorder can manifest itself in any modality but usually involves a neglect of personal or body space, neglect of space that is within reach of the patient (peripersonal space) or neglect of space that is within walking distance (extrapersonal space). There is evidence that neglect is dissociable, in that patients may have impaired perception of peripersonal space, for example, but not of extrapersonal space (Halligan and Marshall 1991). This is an important observation because, even until the mid-1980s, the existence of the disorder was not widely known, was poorly characterized and had no real taxonomy (Halligan and Marshall 1994). It is clear that spatial neglect is not unitary: some aspects are impaired, while others are spared. Heilman *et al.* (1994), for example, suggest that different types of neglect can be defined by the mechanism underlying them: inattention underlies sensory/perceptual neglect; disorders of action and intention underlie motor neglect; and representation underlies the neglect of visual/mental images.

Most spatial neglect deficits are characterized by an apparent unawareness of information or stimuli presented in one hemifield. The neglect is not for stimuli presented to one or other side of the midline of the body but for stimuli found on either side of a fixation point on which the patient must focus. Behavioural examples of spatial neglect include difficulty in reading the time from a clock, missing food on one side of the plate, dressing one side of the body, failing to read words on one side of a newspaper and believing that items in one visual field have been 'lost' (Halligan and Cockburn 1993). Often, patients appear to be unaware of the deficit (anosagnosia) until it is pointed out to them that they are neglecting the left half of their visual field. This lack of awareness can persist and presents a problem for any programme of rehabilitation.

Spatial neglect can be measured in different ways, although there are four standard clinical tasks that tap the disorder. These are line bisection, a cancellation test, copying and spontaneous drawing, and imagery tasks.

Tests of spatial neglect

Line bisection

In the line bisection task, the patient is required to indicate the midline of a straight line by placing a mark at its centre. Normally, the line is horizontal, although vertical and oblique lines have been employed. Typically, the neglect patient errs to the right or, if the lines are vertical or oblique, to the upper end of the line or away from the body, respectively (see Figure 6.7). The longer this line is, the bigger the error made (Butter *et al.* 1988). An increase in the number of errors is seen if the line is placed in the neglected hemispace or if the patient's attention is drawn towards the ipsilateral side (Riddoch and Humphreys 1983).

Cancellation

In the cancellation test, the patient is presented with an array of identical targets on a sheet of paper and has to cross out as many stimuli as possible. Neglect patients fail to cross off those stimuli appearing on the side opposite to their brain lesion, as seen in Figure 6.8 for a patient with a right hemisphere lesion.

Figure 6.7

A spatial neglect patient's performance on the line bisection task (from Halligan and Marshall 1994)

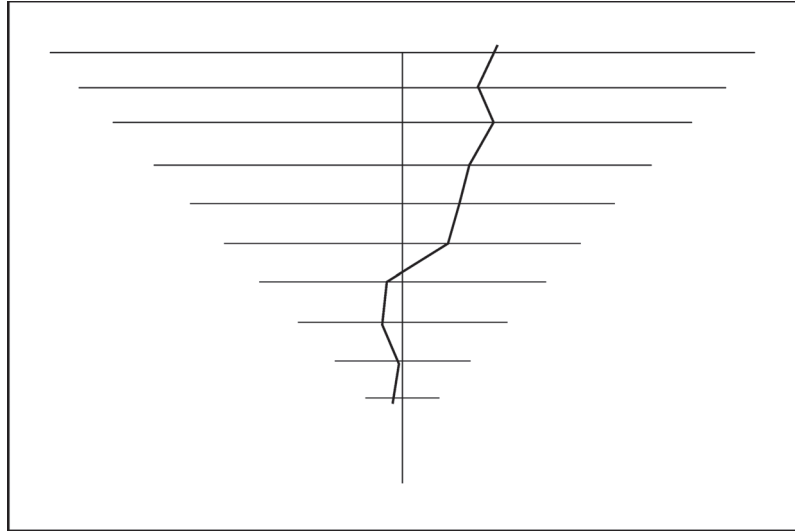
**Figure 6.8**

A spatial neglect patient's performance on a line cancellation task (from Halligan and Marshall 1994)

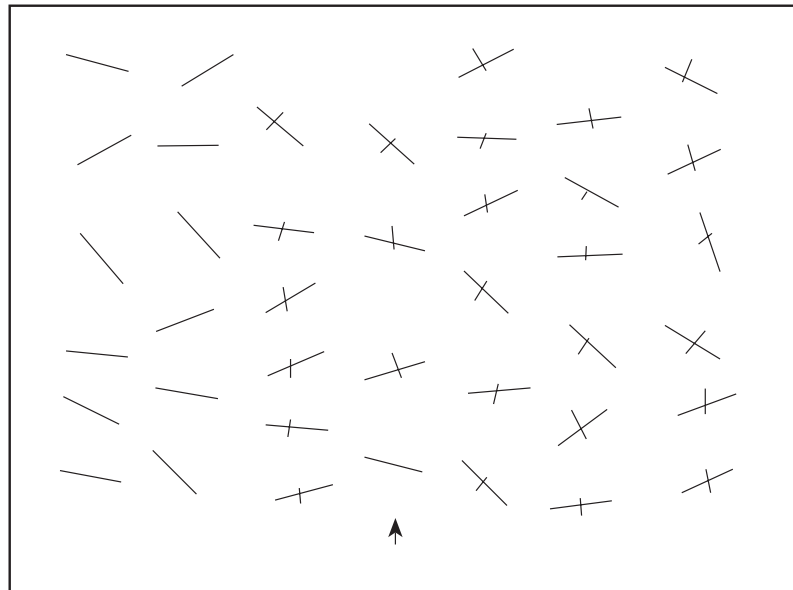

Spontaneous drawing or copying

The neglect patient, when copying or drawing an object, might omit the entire side of the object that is contralateral to the lesion (see Figure 6.9). Perhaps the most famous example of this is clock drawing, where a patient might place all the numbers of the clock face into the right-hand side, leaving the left-hand side blank, as seen in Figure 6.10. Despite

Figure 6.9

An example of a neglect patient's drawing (from Halligan and Marshall 1994)

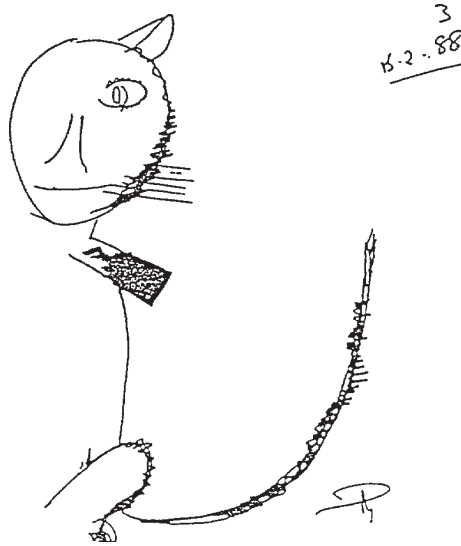
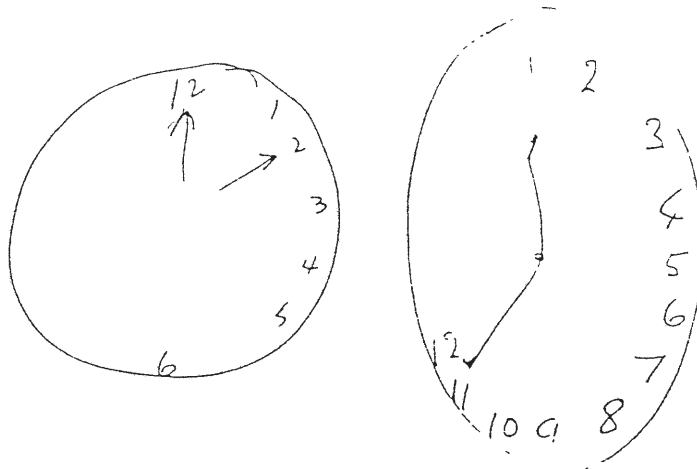

Figure 6.10

The well-known asymmetrical clock face drawn by neglect patients (from Halligan and Marshall 1994)



the clearly failed attempt at drawing, the patient might indicate that the drawing is in fact an accurate representation. Some objects are better copied than others. Asymmetrical nonsense objects, for example, tend to be more poorly copied than meaningful symmetrical ones (Heilman *et al.* 1994). There are degrees of impairment, however. For example, neglect patients may be able to copy the blades of grass on the left side of a picture of a daisy but may neglect the left petals (Ishai *et al.* 1989). Marshall and Halligan's (1988) patient was unable to distinguish between two drawings of a house, one of which had a fire raging on its left side, but when asked which one he would like to live in, chose the one without the fire. This suggests that there may be some covert processing of information in the left hemifield.

Sometimes, the patient may show a degree of contrapositioning, that is the patient transfers elements of the stimuli on the left side to drawings of stimuli on the right side (Halligan *et al.* 1992). For example, the numbers on the left-hand side of a clock may be transposed to the right-hand side. This phenomenon is called allesthesia or allochiria (Meador *et al.* 1991). The reasons for this are unclear, although one explanation is that information on the left side is partially processed but, because the processing of the image is incomplete, features may be incorporated into the good, right side. These partially processed features may be stored in the intact part of some form of visual buffer or may be incorrectly transcribed from this buffer (Halligan *et al.* 1992).

Mental imagery

Mental imagery tasks are designed to tap the patient's representation of a stimulus. One of the controversies in spatial neglect concerns whether the disorder is one of inattention or impaired representation. For example, in one study of patients by Bisiach and Luzzatti (1978), neglect patients were asked to describe, without any cues, the Piazza del Duomo in Milan. When asked to describe the features of the piazza from a viewpoint where their back was to the front door of the cathedral, patients reported more details from the right than from the left side. Yet when asked to describe the piazza from the other side (facing the cathedral), they again supplied more information about the right than the left side, despite the fact that the right side was the same as the left side that they had failed to report from the previous viewpoint. However, a different phenomenon was reported by Guariglia *et al.* (1993). Their 59-year-old patient had suffered an ischaemic attack involving the right frontal lobe and performed adequately on tests of personal, peripersonal and extrapersonal space. However, he was unable to undertake visual imagery of stimuli in the left visual field. These stimuli involved geographical features of Italian piazzas similar to those employed by Bisiach and Luzzatti (see Figure 6.11).

Guariglia *et al.*'s study is unusual because no patient before this report had manifested neglect for visual images without accompanying neglect for visual space, possibly because of the involvement of the right frontal lobe in this patient.

Factors influencing spatial neglect

Short-term memory (especially spatial working memory) deficits can sometimes appear with neglect symptoms, especially if damage is to the right parietal lobe. These deficits may play a greater role in the presentation of neglect than first appears. A failure to hold spatial information in working memory can lead to patients being unable to remember the locations of stimuli. Malhotra *et al.*'s (2004) patient, BI, for example, showed left neglect following right temporo-parietal haemorrhage but also showed impaired memory for spatial location. When given a visual search task (in which a participant is asked to search for as many letter R's as possible in an array of mixed letters), the patient searched the right side of the array repeatedly; he also returned to items he had already noted and regarded them as newly discovered items. An example of BI's search strategy can be seen in Plate 6.1. When his recovery was monitored, his spatial working memory deficit and neglect symptoms improved in tandem, suggesting that subtle memory deficits may underlie some elements of neglect patients' performance. A similar study confirmed this general phenomenon but also localized the working memory deficit to the parietal lobe (Pisella *et al.* 2004). They studied patients with right neglect following parietal or non-parietal injury and presented them with a matrix of four objects. Following this presentation and

Figure 6.11

Maps of the familiar piazzas used in mental imagery tests. The circle containing an arrow indicates the subject's vantage point: the task is to describe what is in front of that point. The black squares indicate those places recalled from mental imagery by neglect patients. They show typical left neglect (reprinted by permission from Macmillan Publishers Ltd: *Nature*, Vol. 364, Unilateral neglect restricted to visual imagery, (Guariglia, C., Padovani A., Pantano, P. and Pizzamiglio, L.), copyright © 1993)

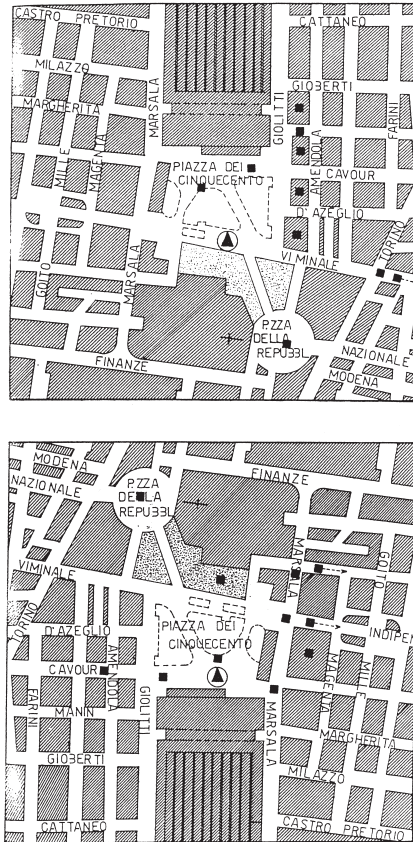

then a visual mask, patients were asked to detect whether the objects had changed location, colour or shape. Memory for the location of the object was significantly more impaired in the parietal group than the non-parietal group.

Task instructions can also affect neglect patients' performance (Baylis *et al.* 2004). Three neglect patients were asked to (1) detect target stimuli in a simple display; (2) detect a target stimulus in a display that contained two objects (participants were asked 'is there a letter E in the display?'; this condition is called scene-based neglect); or (3) indicate whether a stimulus appeared inside another (e.g. 'is there an E in the triangle?'; this condition is called object-based neglect). All participants showed neglect in the first exercise, but they showed only object-based neglect on the last task.

As you saw in Chapter 3, Humphreys and Riddoch (2001) required their neglect patient to search for a target (a cup) either by following an explicit, object-based instruction ('find the cup') or a meaning-based instruction ('find an object you can drink from'). The patient's ability to search for the target was significantly better when following the latter instructions. This improvement was greater still when the array of objects presented to the patient increased, which suggests that neglect patients' problems with visually

searching for objects in large arrays of stimuli (*cf.* Behrmann *et al.* 2004) can be alleviated by careful instruction.

One theory of neglect suggests that it is a representational disorder: as you have already seen, Bisiach and Luzzatti's (1978) patients omitted the left side of the Piazza del Duomo when asked to describe the location from memory (regardless of the patients' vantage point). Their disorder was therefore not a visual one but one that involved an inability to represent visual images in mental space. However, a curious study by Chokron *et al.* (2004) suggests that vision can play a very important role in suppressing neglect symptoms. Chokron *et al.* asked their neglect patients to complete a very simple task: to draw a clock with their eyes open or closed. They also drew objects from memory, with eyes open or closed. The objects were symmetrical, asymmetrical, manipulable or non-manipulable. Figure 6.12 (a)–(d) shows the results of the experiment. When visual feedback was absent, the neglect symptoms diminished: people drew more accurately with their eyes closed.

Figure 6.12

(a) Clock drawing performance in spatial neglect patients, with eyes open (i) and eyes closed (ii); (b), (c) and (d) overleaf

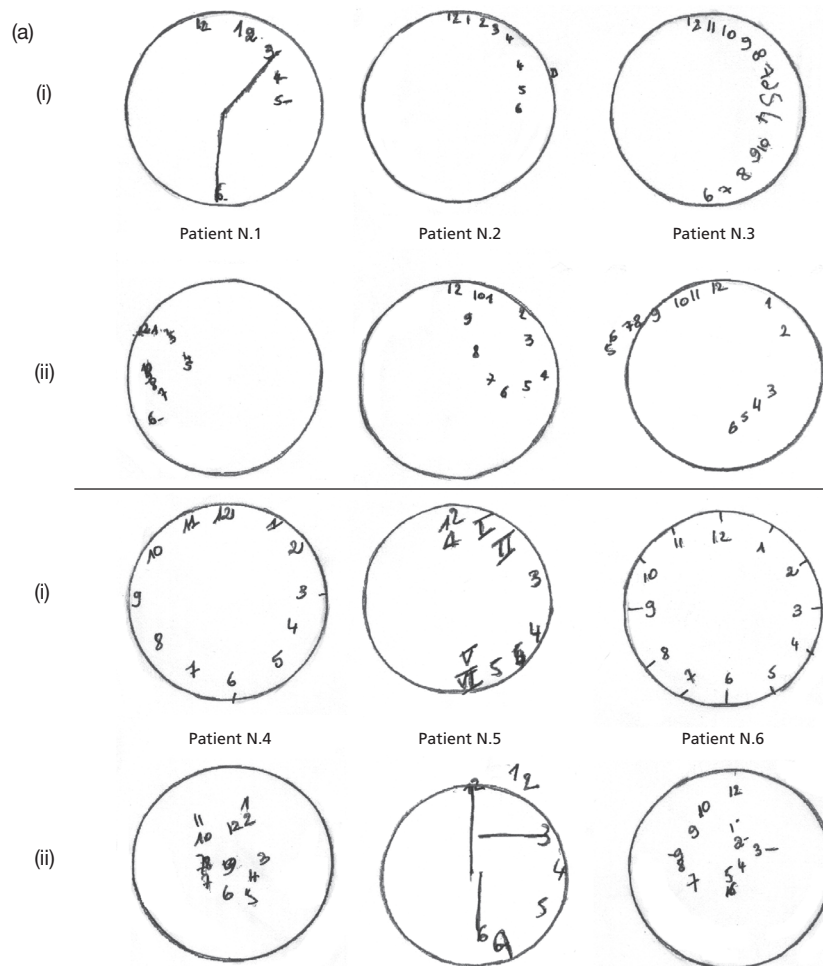
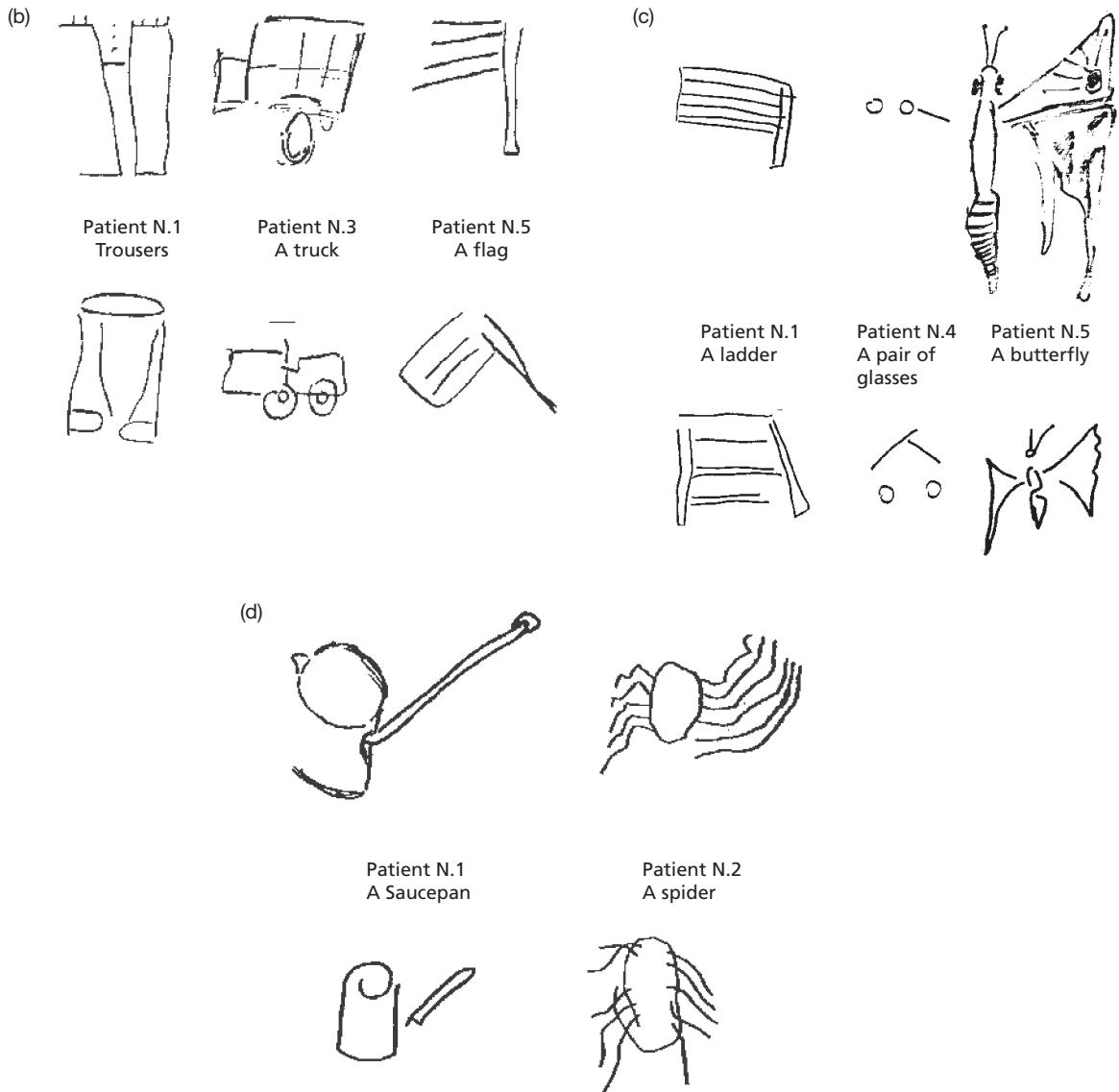

Figure 6.12

(b) drawings of trousers, a truck and a flag, with eyes open (top) and eyes closed (bottom); (c) drawings of a ladder, a pair of glasses and a butterfly, with eyes open (top) and eyes closed (bottom); (d) drawing of a saucepan and a spider, with eyes open (top) and eyes closed (bottom). In these examples, eyes open is associated with greater neglect of the left side of the image (from Chokron *et al.* 2004)



Developmental neglect dyslexia: the case of NT

Although a primarily spatial disorder, neglect can affect visual stimuli other than spatial objects. Some very rare individuals, for example, can show unilateral neglect for words.

NT was referred to clinicians at the age of 9 because he was described as having 'language problems' (Friedmann and Nachman-Katz 2004). He showed no evidence of brain injury or abnormality. However, he did show an unusual linguistic symptom: left word-based neglect dyslexia; that is, he was unable to read the left side of words. He showed no evidence of visuospatial neglect. Some of NT's attempts at writing and drawing are seen in Figure 6.13 (a) and (b).

As a native Hebrew speaker, NT wrote from right to left, and his deficits involved omitting or substituting the final letters of single words (about 96 percent of words showed these irregularities). When given more than a single word, such as word pairs or sentences, he neglects the left part of the word but never the whole word on the left hand side of the paper. Like many neglect patients, his performance is improved if his attention is drawn to the neglected side by making the neglected word part a different colour or making it flash; reading also improves if the words are presented vertically rather than horizontally. More curiously still, he shows no neglect for numbers and symbols.

Figure 6.13

(a) Drawings of a person, butterfly and clock, from memory by NT showing absence of neglect; (b) examples of NT's writing, showing neglect (from Friedmann and Nachman-Katz 2004)

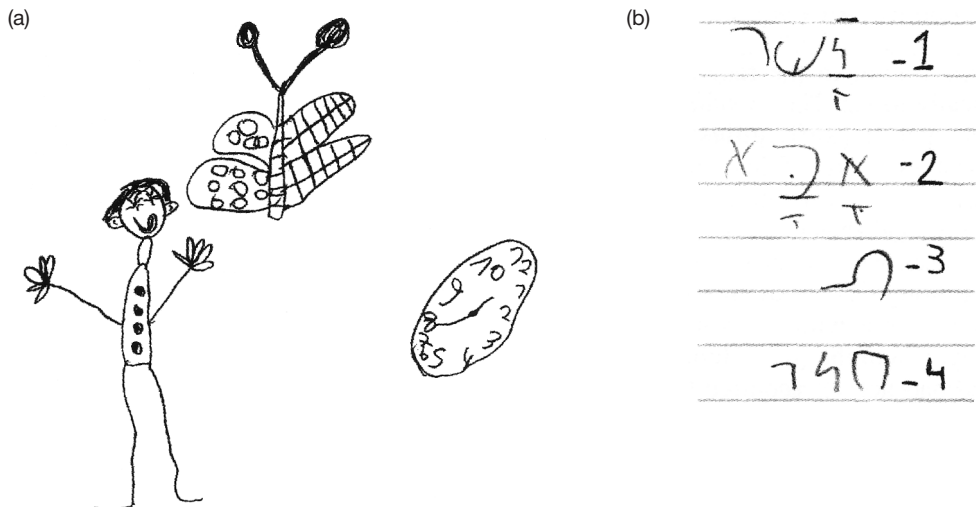

Reducing spatial neglect

Recovery from neglect can be slow, and the disorder can persist for eighteen months (Kinsella and Ford 1985), twelve years (Zarit and Kahn 1974) or indefinitely (Heilman and Valenstein 1979). Several strategies can reduce the degree of spatial neglect seen in patients, however. For example, flashing a red light to the left as the patient is reading, copying or cancelling can reduce neglect, as can requesting that the patient pay more attention to one side of an imagined scene in an imaginary task (Bisiach *et al.* 1981). If stimuli on the right-hand side are made less salient, neglect may also be reduced (Mark *et al.* 1988).

Vibrating the left posterior neck muscles lessens neglect (Karnath *et al.* 1993). This is thought to work by stimulation of the neck muscles that contribute to the neural generation of an egocentric, body-centred frame – the vibration corrects a previously displaced body-centred frame. Caloric vestibular stimulation is one of the more unusual remedial procedures. It involves eliciting a vestibular ocular reflex, which may produce eye movement in the direction opposite to the attentional bias (Rubens 1985). Using this technique, Rubens noted that seventeen out of eighteen stroke patients improved on a battery of spatial neglect tests, although this improvement was short-term. Optokinetic stimulation, which also acts to improve voluntary eye gaze direction, also appears to be partially successful (Bisiach *et al.* 1996). What these procedures appear to be rectifying is the patient's inability to (automatically) shift attention to the neglected side.

Another comparatively successful treatment approach involves the use of wedge-shaped prism lenses: when worn as spectacles, these distort the visual world such that it can be moved to the left or the right (Rossetti *et al.* 1998). Rossetti *et al.* found that wearing such apparatus for less than five minutes resulted in an improvement in neglect test performance even two hours later. An extensive, two-week treatment programme with this prism resulted in significant improvement in neglect patients compared with a control group (Frassinetti *et al.* 2002). Finally, researchers are beginning to harness the promise of virtual reality technology to rectify the neglect, and preliminary results are promising (Kim *et al.* 2004).

Location of lesions in spatial neglect

The lesions found in most neglect patients tend to be focused in the right parieto-temporal cortex, although symptoms of the disorder have also been observed following injury to the inferior frontal and temporal cortex and damage to the basal ganglia and thalamus following a subcortical stroke (Vallar 2001). The precise locus for sensory neglect is thought to be areas 39/40, the inferior parietal lobe (Heilman *et al.* 1994). The frontal eye fields and cingulate gyrus may also be damaged, because these structures have connections with the pulvinar nucleus and the head of the caudate nucleus, both of which, when damaged, are associated with neglect. The presentation of a stimulus activates two pathways: one determines the location of a stimulus, i.e. its spatial position, the other determines what it is. The inferior temporal lobe is thought to mediate the latter, the parietal cortex the former.

Acknowledging that the locus of damage in spatial neglect can be variable, Karnath *et al.* (2004) sought to determine whether any specific region was consistently implicated by examining the brain injury locus of 140 patients admitted with right hemisphere strokes. Of these, seventy-eight patients exhibited symptoms of neglect. When the geography of

their lesions was compared with the non-neglect group, the spatial group showed damage to the right superior temporal cortex, insula, putamen and basal ganglia more often than did the non-spatial group.

Explanations for spatial neglect

As noted earlier, most discussions of why neglect occurs revolve around the notions of attention or representation. There are several theories to account for neglect – and most of the salient ones are summarized in Halligan and Marshall (1994) – but most evoke the concepts of attention, intention, representation or all. For example, neglect has been characterized as a disorder of space awareness (Berti and Rizzolatti 1994), automatic orienting (Posner 1980; Gainotti 1994), hypo- or hyperattention (Ladavas 1994), attention along the left–right axis (Kinsbourne 1987), the distribution of global and local attentional resources (Robertson and Lamb 1991), and noradrenaline system dysfunction (Posner 1993).

One idea suggests that neglect may involve a disturbance in perceptuomotor cortical and subcortical ‘pragmatic maps’, which, when simultaneously activated, allow space awareness. Each map, which has different mechanisms responsible for head, arm and leg movements, has its own ‘neural space representation’ (Berti and Rizzolatti 1994). Damage to a map will result in neglect in some aspect of space. Karnath (1994), on the other hand, suggests that a process of central transformation converts coordinates from sensory input (from the eye, skin and muscle) into an egocentric, body-centred coordinate system. An error in this system means that spatial reference has deviated horizontally across to the ipsilateral (intact) field. Patients may be either hypoattentive, weakly orienting to the affected side (usually the left), or hyperattentive, overattending to the right (Ladavas 1994). Heilman and Valenstein (1979) have cautioned that patients may also suffer from directional hypokinesia, a slowness in initiating movement in the direction contralateral to the brain lesion, which might contribute to the symptoms of neglect manifested in the line bisection task.

According to Marshall and Halligan (1994), hypotheses that attempt to explain neglect wholly in terms of impaired attention are questionable. They cite studies in which patients are unable to bisect lines accurately but are able to place a dot in the middle of a square (Tegner and Levander 1991) or place marks in four corners of a page as evidence against an exclusive attentional hypothesis. Instead, they suggest that what appears to be impaired is the global processing ability of the right hemisphere. Focal processing and global processing of visual images appear to be left and right hemisphere functions, respectively (Fink *et al.* 1996). In neglect patients, the right hemisphere injury brings about this impairment in global processing, reducing visual attention to an ‘attentional spotlight’, which highlights only part of an image. However, the authors suggest that an impaired attentional mechanism underlies many cases of neglect (Marshall and Halligan 1996). What this impaired mechanism does not explain is some of the dissociable symptoms presented by neglect patients.

An interesting series of neglect dissociations was seen in a 72-year-old patient with right brain damage and left neglect (Cubelli and Simoncini 1997). On standard neglect tests she performed as expected, erring to the right. However, when asked to copy or read words, she showed the typical neglect only for the reading aloud task. The ability to copy, and to name letters, was relatively spared. The principal error in the reading task was the deletion of initial letters. This error worsened when the space between letters was widened. Increasing the distance between letters did not affect the copying task.

Cubelli and Simoncini suggest that this dissociation is attributable to differences in word processing. That is, the manifestation of the disorder depends on whether the word is processed at the letter or the string level. When reading aloud, the patient processes the word as a letter string; when copying, she processes the word letter by letter. This hypothesis is similar to those proposed above by Humphreys and Riddoch (1987b) and Halligan and Marshall (1994), both of which emphasize the difference between local or 'within object' representation or processing and global or 'between object' representation or processing.

The fragmentary nature of spatial hemineglect suggests that more than one model may be needed to account for all the symptoms subsumed under spatial neglect. Any general model will therefore need to recognize these differences.

Discussion point: how does brain injury affect artists?

Almost all of the case studies in this book highlight some debilitating effect of brain injury and the ways in which patients try to cope with the consequences of injury. Losing the ability to speak, to recall information, or organize and plan everyday life efficiently are all unwelcome intruders in the world of the normally functioning. But what if the disrupted function is essential to the person's life and provides him or her with a livelihood? Beethoven composed symphonies, Evelyn Glennie plays exceptional xylophone, and Stevie Wonder is an accomplished keyboardist; even James Joyce managed to produce *Ulysses* and *Finnegan's Wake* despite his chronic sight loss (although this is thought to explain some of Joyce's eccentric text). However, none of these, despite their sensory losses, sustained brain injury. In a revealing review of the effect of brain injury on artistic performance, Chatterjee (2004) has documented how talented artists' art may change following brain injury.

The loss of the ability to perceive colour would be one of the more striking difficulties faced by an artist who exploits his or her chromatic palette. Sacks (1995) describes an artist who sustained an injury that left him achromatopsic – the artist's world appeared 'dirty grey', and he reported being unable to imagine colours (and even being unable to dream in colour). Before the injury, the patient painted colourful, abstract creations; after the injury, the paintings became figurative and abstract. Contrast, figure and form were good, as was the patient's ability to understand and describe colour, but his use of colour became haphazard.

Unilateral spatial neglect has more intriguing, if predictable, consequences. Jung (1974) described four early cases of painters who developed neglect following brain injury. One, the German artist Lovis Corinth, had suffered a right hemisphere stroke. His painting changed dramatically: the contours on the left of his work disappeared, and details became misplaced. Blanke *et al.* (2003) reported the case of a 71-year-old artist who could colour the right side of her paintings normally and evenly but paid minimal attention to the left. Plate 6.2 gives an example of the patient's art following injury. Neglect for colour was greater than neglect for form in the majority of the patient's paintings. Painter IK showed right neglect, where entire canvases would be created in exuberant colour but the right side lacked detail and form (Marsh and Philwin 1987).

Perhaps the most famous recent example of unilateral spatial neglect is the Italian film director Federico Fellini, whose disorder was reported by Cantagallo and Della Sala (1998). At the age of 73, Fellini suffered a stroke in the middle cerebral artery of

the right parietal lobe that caused left extrapersonal spatial neglect that persisted for two months. As well as being a celebrated film director, Fellini is also an accomplished cartoonist, and his completion of neglect tests is peppered with his cartoonish embellishments. His original cartoons showed neglect of the left side. Figure 6.14 (a), (b) and (c) illustrate some of Fellini's attempts. Fellini's neglect did not appear to be representational (he could imagine both sides of his visual field), and he was completely aware of his deficits. Unlike patients in previous reports, his increased awareness did not lead to a decrease in his neglect (Pizzamiglio *et al.* 1992).

Like Fellini, artists may begin to recover their ability to attend to the left; sometimes, they will use broader strokes than normal or may be more expressive, as the painters Loring Hughes and Louis Corinth did.

At least neglect patients can recognize their creations. Some patients with visual agnosia are unable to do this. Wapner *et al.* (1978) reported the case of a 73-year-old amateur artist who developed visual agnosia following a stroke. The artist would draw extremely laboriously but failed to recognize what he drew. He could identify the general shape of the object and describe its function, and he even tried to identify it from its parts, but he could not put a label to it. His agnosia was perceptual rather than conceptual, because he would sometimes describe the functions of parts of the object he drew (e.g. what a telephone was for).

A different pattern emerged in Franklin *et al.*'s (1992) patient MH, a 77-year-old commercial artist who retained the ability to draw after left peri-Sylvian atrophy, but the quality of her drawings would depend on the context in which she was asked to draw. When she copied a painting by Botticelli, or drew one of the medical staff from hospital, her drawings were beautiful. However, when she was given the name of an object or subject, her drawings ranged from unrecognizable to crude and unassured. This impairment extended to personally meaningless objects such as geometric forms – when present before the artists, she could draw them; when removed, she drew them poorly. In this case, the agnosia would be conceptual rather than perceptual, because the artist was unable to retain a concept of the target object in mind. A similar deficit was seen in Schwartz and Chawluck's (1990) patient, Susan G; she too could classify objects perceptually and draw competently when copying but was unable to draw well when the object was not present.

Agnostic patients can sometimes imagine the objects they would like to draw. Botez *et al.* (1985) report the case of a 38-year-old teacher and amateur charcoal drawer who was unable to imagine people, places or objects following dilation of the right lateral ventricle. Her mental imagery appeared to be shot. Copying objects presented little problem, but when the object was removed from sight, her drawings became simple and schematic. Like MH, when she was given the name of an object to draw, she could not do this competently.

Perception seems to be the most likely casualty in the artist's battle with brain damage, but there are some cases of impairment to other functions that lead to some unusual artistic consequences. One patient, for example, the Bulgarian artist Zlatko Boiyadjiev, exhibited a natural, pictorial style prior to the development of aphasia (Zaimov *et al.* 1969). After the aphasia, his art became bold, rich and colourful, full of striking, energetic lines and replete with bizarre imagery. Another artist with aphasia, the Polish artist RL (an assistant professor in Lublin), was known for highly symbolic paintings. Following aphasia, he produced very well-executed charcoal drawings, self-portraits and landscapes (Kaczmarek 1991). No matter how hard he tried, he never did recover the symbolism of his art that existed before the aphasia.

Figure 6.14

(a) Federico Fellini's MRI scan; (b) and (c) examples of his spatial neglect test performance (from Cantagallo and Della Sala 1998)

(a)

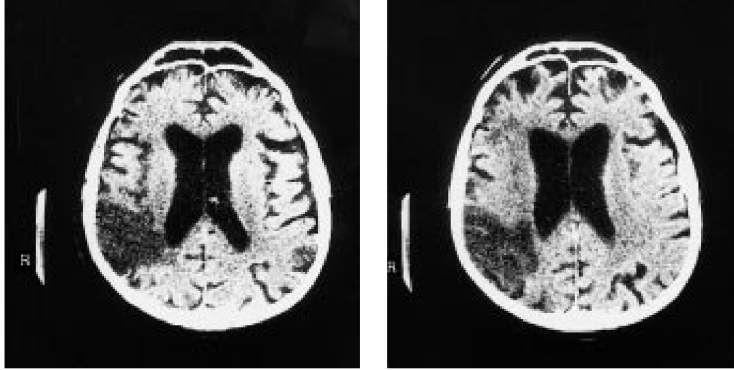

(b)

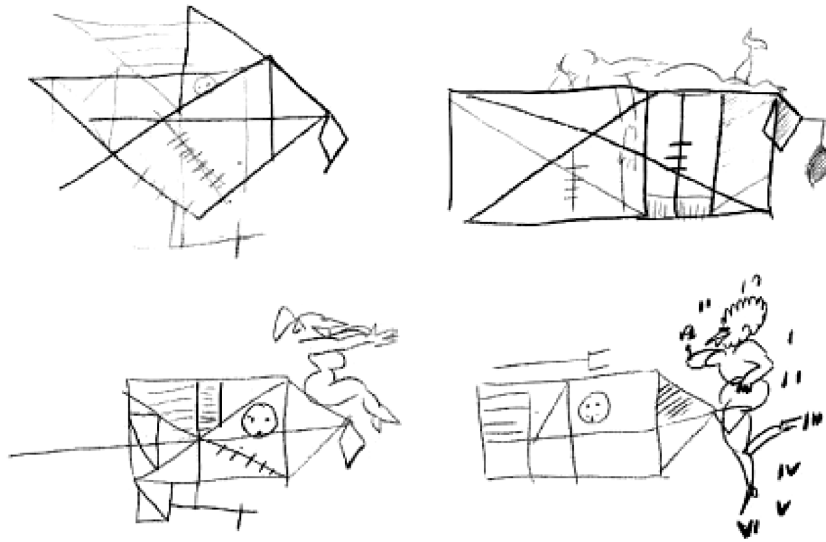

(c)

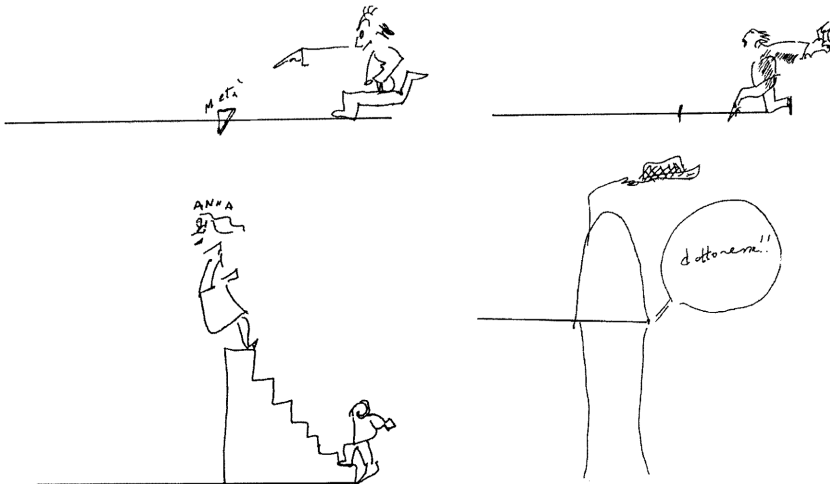

Summary

Blindsight describes the ability of patients with striate cortex damage, and who are therefore cortically blind, to complete perceptual tasks successfully despite self-reports of being unaware of stimuli being presented. Blindsight is rare, even in patients with striate damage, which suggests caution in interpreting the meaning of its symptoms. Agnosia is a perceptual disorder that refers to the inability to recognize objects in any sensory modality despite intact sensory apparatus. Apperceptive visual agnosia or visual object agnosia refers to a rare impairment in object perception and is attributable to right-sided parietal lesions. Associative visual agnosia is a rare disorder that describes an inability to assign meaning to objects despite normal vision and is associated with posterior left hemisphere lesions. There may be dissociations evident in that some classes of object may be recognized and identified and others not. Marr's theory suggests that apperceptive agnosia results from a failure to determine the major and minor axes of a three-dimensional image. An alternative model suggests that there may be a deficit in recognizing distinctive features. Associative agnosia may result from an impairment in connecting the output of perceptual analysis with the patient's knowledge. An alternative hypothesis suggests that independent systems exist that mediate different forms of recognition. There may be category-specific dissociations in visual recognition ability. For example, patient JBR is unable to name living things but can name non-living things. Prosopagnosia refers to the inability to recognize individual faces, although the perception of facial expression and of the age and sex of a face is spared. Damage is usually to the right hemisphere and unilateral, although bilateral lesions have been reported. There is evidence that some prosopagnosic patients may be able to recognize individual faces covertly. Unilateral spatial neglect describes an inability to attend to stimuli in one hemifield (usually the left). Damage to the right parietotemporal area results in left neglect (the more common and more severe); damage to the homologous left area results in right neglect. It is not a unitary disorder. The principal failure in spatial neglect appears to be the inability to attend voluntarily and automatically to stimuli on the neglected side.

Recommended further reading

Disorders of visual perception – general

- Chatterjee, A. (2004). Neuropsychology of art. *Neuropsychologia*, 42, 1568–83.
- Cortex (2005). Forum on 'methodological critique on category specificity'. *Cortex*, 41, 6.
- De Valois, K.K. (2000). *Seeing*. Oxford: Oxford University Press.
- Farah, M.J. (2001). *The Cognitive Neuroscience of Vision*. Oxford: Oxford University Press.
- Forde, E.M.E and Humphreys, G.W. (2002). *Category Specificity in Brain and Mind*. Hove, UK: Psychology Press.
- Goodale, M. and Milner, D. (2003). *Sight Unseen: An Exploration of Conscious and Unconscious Vision*. Oxford: Oxford University Press.
- Humphreys, G.W. (2001). *Case Studies in the Neuropsychology of Vision*. Hove, UK: Psychology Press.
- Kurbat, M.A. and Farah, M.J. (1998). Is the category-specific deficit for living things spurious? *Journal of Cognitive Neuroscience*, 10, 3, 355–61.
- Logothetis, N.K. (1999). Vision: a window on consciousness. *Scientific American*, November, 44–51.

- Milner, A.D. (1998). Streams of consciousness: visual awareness and the brain. *Trends in Cognitive Sciences*, 2, 1, 25–30.
- Rees, G. (2001). Neuroimaging of visual awareness in patients and normal subjects. *Current Opinion in Neurobiology*, 11, 150–6.
- Sacks, O. (2003). The mind's eye: what the blind see. *The New Yorker*, 48–59.
- Wallis, G. and Bulthoff, H. (1999). Learning to recognise objects. *Trends in Cognitive Sciences*, 3, 1, 22–31.
- Zeki, S. (2001). Localization and globalization in conscious vision. *Annual Review of Neuroscience*, 24, 57–86.

Blindsight

- Cowey, A. (2004). The 30th Sir Frederick Bartlett lecture: fact, artefact, and myth about blindsight. *The Quarterly Journal of Experimental Psychology*, 57A, 4, 577–609.
- Kentridge, R.W., Heywood, C.A. and Weiskrantz, L. (1997). Residual vision in multiple retinal locations within a scotoma: implications for blindsight. *Journal of Cognitive Neuroscience*, 9, 2, 191–202.
- Marcel, A.J. (1998). Blindsight and shape perception: deficit of visual consciousness or of visual function? *Brain*, 121, 1565–88.
- Weiskrantz, L. (1986). *Blindsight: A Case Study and Implications*. Oxford: Oxford University Press.
- Weiskrantz, L. (1999). *Consciousness Lost and Found*. Oxford: Oxford University Press.
- Zeki, S. and ffytche, D.H. (1998). The Riddoch syndrome: insights into the neurobiology of conscious vision. *Brain*, 121, 25–45.

Visual agnosia

- Grossman, M., Galetta, S. and D'Esposito, M. (1997). Object recognition difficulty in visual apperceptive agnosia. *Brain and Cognition*, 33, 306–42.
- Milner, A.D. (1998). Streams of consciousness: visual awareness and the brain. *Trends in Cognitive Sciences*, 2, 1, 25–30.

Face processing and prosopagnosia

- Bruce, V. and Young, A.W. (1998). *In the Eye of the Beholder: The Science of Face Perception*. Oxford: Oxford University Press.
- Ellis, H.D. (1996). Bodamer on prosopagnosia. In C. Code, C.-W. Wallesch, Y. Joannette and A.R. Lecours (eds), *Classic Cases in Neuropsychology*. Hove, UK: Psychology Press.
- Farah, M.J., Wilson, K.D., Drain, M. and Tanaka, J.N. (1998). What is 'special' about face perception? *Psychological Review*, 105, 482–98.
- Gorno-Tempini, M.L., Price, C.J., Josephs, O., Vandenberghe, R., Cappa, S.F., Kapur, N. and Frackowiak, R.S.J. (1998). The neural systems sustaining face and proper-name processing. *Brain*, 121, 2103–18.
- Kanwisher, N., Tong, F. and Nakayama, K. (1998). The effect of face inversion on the human fusiform face area. *Cognition*, 68, B1–B11.
- Moscovitch, M., Winocur, G. and Behrmann, M. (1997). What is special about face recognition? Nineteen experiments on a person with visual object agnosia and dyslexia but normal face recognition. *Journal of Cognitive Neuroscience*, 9, 5, 555–604.
- Rhodes, G., Byatt, G., Michie, P.T. and Puce, A. (2004). Is the fusiform face area specialised for faces, individuation, or expert individuation? *Journal of Cognitive Neuroscience*, 16, 2, 189–203.
- Sacks, O. (1986). *The Man Who Mistook his Wife for a Hat*. London: Picador.

- Taylor, M.J., Batty, M. and Itier, R.J. (2004). The faces of development: a review of early face processing over childhood. *Journal of Cognitive Neuroscience*, 16, 8, 1426–42.
- Young, A.W., Aggleton, J.P., Hellawell, D.J., Johnson, M., Brooks, P. and Hanley, J.R. (1995). Face processing impairments after amygdalotomy. *Brain*, 118, 15–24.
- Young, A.W., Newcombe, F., de Haan, E.H.F., Small, M. and Hay, D.C. (1993). Face perception after brain injury. *Brain*, 116, 941–59.

Spatial neglect

- Cantagallo, A. and Della Sala, S. (1998). Preserved insight in an artist with extrapersonal spatial neglect. *Cortex*, 34, 163–89.
- Halligan, P.W. and Marshall, J.C. (1991). Left neglect for near but not far space in man. *Nature*, 350, 498–500.
- Karnath, H.O., Berger, M.F., Kuker, W. and Rorden, C. (2004). The anatomy of spatial neglect based on voxelwise statistical analysis: a study of 140 patients. *Cerebral Cortex*, 14, 10, 1164–72.
- Manly, T. and Mattingley, J.B. (2004). Visuospatial and attentional disorders. In L.H. Goldstein and J.E. McNeil (eds), *Clinical Neuropsychology: A Practical Guide to Assessment and Management for Clinicians*. Chichester, UK: John Wiley and Sons.
- Robertson, I.H. and Halligan, P.W. (1997). *Spatial Neglect: A Clinical Handbook for Diagnosis and Treatment*. Hove, UK: Psychology Press.
- Special issue of *Cortex* on ‘Spatial neglect: a representational disorder?’, 2004, 40, 2.
- Vallar, G. (1998). Spatial hemineglect in humans. *Trends in Cognitive Sciences*, 2, 3, 87–97.

7

Movement disorders

Some disorders of the human motor system

Parkinsonism and Parkinson's disease

Clinical features

Neuropathology

Neurotransmission

Treatment

Aetiology

Huntington's disease

Clinical features

Neuropathology

Treatment

Aetiology

Sydenham's chorea

Dyskinesia

Gilles de la Tourette syndrome

Wilson's disease

Motor neuron damage

Myoclonus

Ataxia

Apraxia

Tests of apraxia

Types of apraxia

Cerebral basis of apraxia

Theories of apraxia

Hemiplegia

Summary

Recommended further reading

Some disorders of the human motor system

Disorders of the human motor system come in many forms. There are the more obvious and commonplace ones, such as impeded walking following the fracture of a leg. This chapter, however, describes some of the most common movement disorders that arise from damage to the central nervous system. Some disorders result from degeneration of neurons in deep, subcortical structures, others from lesions to the cortex itself. These cortical lesions produce less fatal but psychologically unusual consequences. The subcortical structures most often involved in motor dysfunction are the basal ganglia – a collection of structures in the forebrain that includes the caudate nucleus, putamen and globus pallidus.

Disorders involving these nuclei are called extrapyramidal disorders and involve either excessive motor activity (such as that seen in Huntington's disease, Wilson's disease and Gilles de la Tourette syndrome) or restricted movement (such as that seen in parkinsonism). This chapter begins with a description of the extrapyramidal disorders.

Parkinsonism and Parkinson's disease

Parkinson's disease was first described by James Parkinson in 1817. The motor features of the disease are known collectively as parkinsonism. Its classical features include akinesia (general loss of movement), rigidity (resisting passive movement) and tremor at rest. Tremor at rest arises from alternating agonist and antagonist contraction in distal muscles of the arm. The most common manifestation of this is 'pill rolling', where the fingers appear to imitate the rolling of a pill. There is usually no tremor of the lip, neck or tongue. Although exacerbated by stress, tremors are reduced during sleep and voluntary movement. Akinesia can take the form of slowness of movement (bradykinesia), reduction of movement (hypokinesia) or lack of spontaneous and automatic voluntary movement (akinesia itself). Axial akinesia refers to impaired movement of the trunk or proximal muscles; this makes turning difficult for the parkinsonian patient. There may also be stooped posture, speech difficulties, excessive sweating, incontinence and/or constipation.

The early symptoms appear as disturbed fine motor control in the hand: this makes activities such as writing or doing up buttons difficult. Speech becomes hoarse, the swing of the arm might be reduced, and making two simultaneous movements becomes problematic. The posture difficulties (such as falling over following a period of hesitation or 'freezing') tend to be resistant to therapy. There may be pronounced executive dysfunction (Zakzanis *et al.* 1999); recognition memory may be normal but free recall may be impaired, suggesting that retrieval may be more problematic than encoding.

The most common form of parkinsonism occurs with idiopathic Parkinson's disease (PD for short), where the aetiology of the disorder is unknown. Parkinsonism can also occur secondary to other degenerative diseases. A history of stroke or hydrocephalus is symptomatic of parkinsonism.

Clinical features

A clinical diagnosis of PD involves confirming the presence of two of the three classic symptoms outlined above. Diagnosis is probable if onset of the motor disturbance is asymmetrical, if there is rest tremor, if the patient is responsive to the standard drug treatment and if the fluctuations in symptoms following the administration of this drug are present. There appear to be three distinct syndromes of PD. One is characterized by akinesia, tremor and rigidity (mixed type), one by akinesia and rigidity with minimal or absent tremor (akinetic-rigid type), and another by tremor with almost total absence of akinesia or rigidity (tremor-dominant type).

The mean age of onset of the disease is between 40 and 70. It affects approximately 0.15 percent of the world's population, a figure that increases to 0.5 percent in those over 50 years old. The incidence has been given at five in 100 000 for individuals under 54; 32

in 100 000 for individuals between 55 and 64; 113 in 100 000 for individuals between 65 and 74; and 254 in 100 000 in individuals between 75 and 84 (Rajput *et al.* 1984). It is a progressive disease with no clear evidence of genetic transmission. The common causes of death are cardiovascular disease, tumour, cerebrovascular disease and bronchopneumonia. The underlying causes are unknown, although many explanations have been given (see below).

Neuropathology

The most prominent neuropathological feature of PD is a loss of the striatal dopamine pathway, which runs from the substantia nigra to the neostriatum (caudate nucleus and putamen) and globus pallidus. There is degeneration of the ventrolateral layer of the substantia nigra projecting to the striatum (Fearnley and Lees 1991). Material called Lewy bodies is also found in the substantia nigra and locus coeruleus, which may be a diagnostic marker for the disease (although other diseases with parkinsonian symptoms also show evidence of these Lewy bodies, and Lewy bodies are also found in other parts of the brain, such as the cortex and raphe nuclei).

Neurotransmission

Dopamine and dopamine's metabolite, bolite homovanille, have been found to be depleted in the caudate nucleus, putamen, substantia nigra and globus pallidus in patients with PD, with greater loss in the putamen (the loss is about 70–90 percent) than in the caudate nucleus (Kish *et al.* 1988). The residual striatal neurons may compensate for the loss of dopamine by increasing their activity, increasing dopamine or increasing dopamine's release. These compensatory measures mean that clinical symptoms do not present themselves until dopamine levels have declined by approximately 80 percent, the 'threshold' for PD (Strange 1992). Levels of postsynaptic striatal D1 and D2 dopamine receptors have been found to be greater in PD patients who had not received L-dopa prior to death, whereas normal levels were found in those patients who had received L-dopa (Seeman and Niznik 1990). Overall, levels were found to be extremely variable, however. There is also a reduction in GABA and 5-hydroxytryptamine (5-HT) in the striatum and substantia nigra (where these two transmitters predominantly exist). The serotonin reduction may be due to the effects of drug therapy (Levodopa), which reduces 5-HT.

The complex picture of neurotransmission involvement in parkinsonism has in part been accounted for by a model of basal ganglia circuitry that suggests a complex arrangement of indirect and direct striatal outputs (Alexander *et al.* 1990). The indirect pathway is thought to be overstimulated in PD by an increase in glutamate release. This is normally inhibited by D2 receptors, but the outer globus pallidus becomes overactivated. Meanwhile, the internal part becomes overstimulated, as does the pathway leading to the thalamus. This pallidothalamic projection is inhibitory but overactive; therefore, it has an over-inhibitory effect on thalamic neurons. The direct pathway represents the inhibitory neurons of the striatopallidal pathway to the internal globus pallidus. This is excited by dopamine, but the pathway is underactive. Both pathways increase the activity of the internal globus pallidus.

Plate 7.1 illustrates the brain regions and neurotransmitter systems implicated in PD.

Treatment

A summary of the psychopharmacological therapies for PD is listed in Table 7.1. Levodopa (L-dopa), the precursor of dopamine and the first dopaminergic therapy for PD, reduces the symptoms of PD significantly (Cotzias *et al.* 1967). L-dopa is taken up by nigrostriatal nerve endings, where it is decarboxylated and dopamine is released. Since striatal dopamine loss is characteristic of PD, increasing levels of dopamine might seem a sensible treatment. L-dopa is used instead of dopamine itself because L-dopa can penetrate the blood/brain barrier (and is converted into dopamine), whereas orally administered dopamine cannot. One early problem was that a high dose of L-dopa led to its peripheral decarboxylation before reaching the brain. However, 1 g per day of L-dopa plus the administration of a peripheral decarboxylase inhibitor (PDI, 100 mg per day) reduces many PD symptoms, although there are side-effects, such as dyskinesia (movement disturbance, see section below) and psychiatric disturbances. The normal dose of L-dopa is about 2–8 g per day but is reduced if taken with the PDIs: the combination of these two has been described as the ‘gold standard’ of PD drug treatment (Oertel and Quinn 1996). About 15 percent of patients are unresponsive to treatment, but these are not likely to have PD. After chronic treatment, improvement may also be seen to wane, with motor oscillations occurring either because the drug is ‘wearing off’ or because of the fluctuating clinical state of the subject.

Table 7.1 Some psychopharmacological treatments for parkinsonism

Substance	Generic name	Example
L-dopa	L-dopa	Lavodopa, brocadopa
AADC inhibitors	L-dopa, benserazide, co-beneldopa L-dopa, carbidopa, co-careldopa	Madopar Cronomet, Sinemet
Dopamine receptor agonists	Apomorphine Bromocriptine alpha-dihydroergocryptine Lisuride Piribedil	Britaject Bagren, Bromocriptin, Parlodel Alminid Revanil, Permax Trivastal
MAO B inhibitors	Selegiline (deprenyl)	Eldepryl, Deprenyl
Adamantanamine	Amantadine HCl, memantine HCl	Mantadine, Symmetrel, Tregor
Anticholinergics	Benztropine Biperiden HCl Biperiden lactate Bornaprin Metixen Orphenadrine HCl Orphenadrine dihydrogencitrate Procyclidine Trihexphenidyl	Cogentin, Cotulate Akineton Akineton lactate Sormorden Mexitil, Tremonil Biorphen, Disipal Norflex Arpicolin, Kemadrin Artane, Bentex, Broflex
Anti-emetics	Domperidone	Motilium

Other drugs used include dopamine agonists acting on pre- and postsynaptic receptors, but they are not as effective as L-dopa, and there are gastrointestinal side-effects. However, they have a low incidence of response fluctuation. Examples include bromocriptine and lisuride. The most potent is apomorphine (an agonist for certain types of dopamine receptor – D1, D2 and D3). Monamine B inhibitors such as selegiline (deprenyl) are sometimes used. These are thought to reduce the breakdown of dopamine, thus producing a greater dopamine lifespan. Although it does enhance the effect of L-dopa and enables a reduction in L-dopa administration to take place, the drug on its own is not as effective as L-dopa. Antiviral agents such as amantadine have been used to combat parkinsonism and are thought to increase dopamine synthesis via dopamine reuptake blockage. This can delay the need for L-dopa in young cases, but there are rare side-effects (epileptic seizures). Finally, anticholinergic drugs, which reduce rigidity and rest tremor, have been used, although they do cause side-effects such as urinary constipation and blurred vision. The search for new drug treatments, especially treatment for debilitating illnesses such as PD, is ongoing, and new, experimental drugs such as the dopamine agonist corbergoline and the weak MOAB inhibitor budipine are both currently being systematically studied for their long-term effects.

There are two other radical forms of treatment that may be appropriate for PD: surgery and transplantation. Surgery is used for reducing drug-resistant tremor and sometimes takes the form of a unilateral thalamotomy (also called stereotactic coagulation), removal of one side of the thalamus. The procedure is illustrated in Plate 7.2. This reduces rest tremor in 80–90 percent of patients operated on. A less destructive method is to stimulate the nucleus ventralis and intermedialis of the thalamus. This too is effective. Tremors and rigidity are also alleviated by pallidotomy, as is akinesia when the internal pallidus is lesioned (Svennilson *et al.* 1960). Pallidotomies appear to have quite long-lasting beneficial effects on bradykinesia and rigidity (Laitinen *et al.* 1992; Rodriguez-Oroz *et al.* 2005).

Transplantation of intracerebral dopamine-synthesizing tissue perhaps holds the most remarkable possibilities for reducing PD symptoms. Originally, the rationale for transplantation was based on primate models of parkinsonism. Dopamine-synthesizing cells are transplanted into the putamen or caudate nucleus, which may then begin to release dopamine or may restore the depleted neuronal circuitry. Studies are currently only at rudimentary stages. However, work with animal models of parkinsonism (and dementia), together with early trials with humans, show promising signs (and is discussed later in the chapter).

Discussion point: can nicotine treat Parkinson's disease?

Recent years have seen a growing interest in the role of nicotine in Parkinson's disease (Quik 2004). The interest stems from the curious finding that the disease is less prevalent in smokers (Quik and Kulak 2002). It is not the case that those who are prone to the disease die earlier because of the smoking (and thus distort the figures) either (Gorell *et al.* 1999). So why does nicotine appear to be so important to Parkinson's disease (PD)?

One theory suggests that nicotine stimulates the neurotransmitter pathway damaged in PD – the pathway involving striatal dopamine neurons. Another theory, based on experimental animal models, suggests that the chemical protects neurons from degeneration. Is there evidence for either of these theories?

Nicotine acts by stimulating a specific class of receptors – nicotinic ACh (nACh) receptors. Animals with damage to nigrostriatal, dopaminergic neurons and patients with PD have been found to show depletion of these receptors (Zoli *et al.* 2002; Guan *et al.* 2002). Given the importance of these receptors to movement, perhaps nicotine could benefit PD by enhancing dopamine release, which in turn reduces motor problems. It might also protect nigrostriatal neurons from damage. When a nicotinic agonist was administered with lower levels of L-dopa, there was an improvement in parkinsonian symptoms (normally, lower L-dopa administration leads to worsening symptoms and side-effects). The improvement was similar to high levels of L-dopa alone (Schneider *et al.* 1998).

Another mechanism by which nicotine could work might involve its effects on other neurotransmitters. When nACh receptors are stimulated, for example, toxicity in the brain is reduced. Alternatively, nicotine could eliminate the production of toxins by altering an enzyme called monoamine oxidase (Obata *et al.* 2002). Its effects might therefore be akin to that of an antioxidant.

If this evidence provides support for a role for nicotine in PD symptom reduction, it seems reasonable to predict that products designed to release nicotine by means other than cigarettes – such as nicotine patches or gum – should alleviate motor disturbances. There is evidence that these products do remove some motor disabilities (Ishikawa and Miyatake 1993), but other studies have found no positive effect. One reason for this, according to Quik (2004), might be that the constant release of nicotine produced by patches results in a chronic desensitization of receptors: they become less sensitive to the stimulation after a while. Quik (*ibid.*) also suggests that nicotine may be just one compound from several that could be valuable to PD.

Aetiology

There has been some attempt to link environmental agents with the appearance of PD. For example, factory workers exposed to manganese or carbon disulphide for long periods may exhibit symptoms very much like parkinsonism (akinesia and rigidity). Parkinsonism also appears secondary to other disorders. Carbon monoxide poisoning and some antipsychotic drugs are associated with parkinsonian symptoms. Strangely, a high incidence of three degenerative diseases – amyotrophic lateral sclerosis, parkinsonian syndrome and senile dementia – has been reported on the island of Guam (Garruto and Yase 1986), a finding thought to be associated with water supplies having low magnesium and calcium but high aluminium content, or with the consumption of cycad seed (the B-N-methylamino alanine in the seed is thought to be a neurotoxin). As the neurotoxin is likely to have been taken out of the seed, however, another candidate seems more likely (Strange 1992).

The substance 1-methyl-4-phenyl-1,2,3,6-tetrahydropyridine (MPTP), a by-product of the synthesis of meperidine, a synthetic heroin substitute erroneously sold to heroin addicts in California in 1982, has been found to produce symptoms similar to those found in PD (Langston 1985; Singer *et al.* 1987). These addicts also showed degeneration of the striatal dopamine pathway. The likely toxin would appear to be the MPP⁺ produced by monoamine oxidase B activity and taken up by dopamine cells. Other substances containing MPP⁺ include certain foods and pesticides (paraquat). There is evidence of a high incidence of PD in Canadian agricultural regions, where the use of pesticides is high. Although there is little evidence to suggest a genetic component to PD, a report of a large kindred with inherited PD has been published (Golbe *et al.* 1990).

Strange (1992) has proposed a theory whereby PD is thought to result from an abnormal loss of mesostriatal cells in addition to the loss of these cells occurring normally with age. When the threshold for the loss is reached, Strange argues, the symptoms of parkinsonism emerge.

Given the detailed documentation available regarding the neuropathology, it is disappointing that studies have not yet been able to identify the cause of this neuropathology in parkinsonism. Current treatment is dominated by L-dopa although promising alternatives, such as surgery and, more controversially, grafting, are being investigated.

Huntington's disease

Another well-known degenerative motor disorder is Huntington's disease (HD), first described by George Huntington, who studied the incidence of chorea (jerky, dance-like movements) in families in Long Island, New York. The disease is inherited, autosomal-dominant and appears to involve a mutation of a gene on the arm of chromosome 4. The result is degeneration of small and medium-sized neurons in the striatum, particularly GABAergic neurons, which project to the globus pallidus. The disorder can be traced back many years in a person's history, and because of its inherited status, it can be traced back many centuries. Historically, it has been thought that the notorious witches of Salem may have suffered from HD.

Clinical features

HD is rare and affects approximately 0.01 percent of the world's population (the prevalence is two to seven individuals per 100 000). Age of onset is usually around 40–50 (although cases in their twenties have been reported), and the average duration of the disorder is nineteen years. A small percentage of patients has earlier onset (i.e. before age 20). This is the juvenile version of the disorder, and physical decline is most common in this group. It is a progressive disorder, and death can follow between fifteen and twenty years after onset (Folstein 1989).

The most prominent feature of HD is involuntary, choreiform (dance-like) movement and dementia. Less frequently, there may be akinesia, rigidity and disturbances in personality (especially if there is neuron loss from the frontal cortex). Movements appear out of control and jerky, and the patient may also have difficulty speaking and standing. The first signs of the disease might manifest themselves in changes in personality or in gradual clumsiness or unsteadiness. Early motor signs include restlessness in the fingers, toes and face. There is a variant of HD called the akinetic-rigid type (which as the name suggests involves akinesia and rigidity), in which all striatal neurons become degenerated. In common HD, interneurons projecting to the lateral globus pallidus degenerate. In the late stages of the disorder, patients may be bedridden and in a vegetative state, and they often die of complications related to their immobility or difficulties in swallowing.

Neuropsychological symptoms include delayed recall, learning and cognitive flexibility (Zakzanis *et al.* 1999). Retrieval of information may be inefficient – recognition memory is better than recall – but although learning is impaired, the rate of forgetting in HD patients is normal. Because frontal neuronal degeneration may occur, attention and executive function deficits can be observed.

The disease is inherited and is an autosomal dominant one and, as a consequence, the child of an HD parent has a 50 percent chance of developing the disease. If the gene is present, it will be expressed. This poses a problem, since those at risk will have had children by the time of onset. The children of these parents may make a decision not to have any children, which would terminate the line of the disease. Gene probes using markers on chromosome 4 can predict the disorder's appearance but not its time of onset. However, the application of this test presents a hellish dilemma. If the test indicates that the individual is free of the disease, all well and good. If, on the other hand, the test is positive and indicates that the individual will develop HD, then the individual is resigned to the fact that the disease will develop later. Given the absence of effective treatment, this is not a pleasant scenario.

Neuropathology

There is normally a reduction in brain size of up to 20 percent in HD patients at *post mortem*. Neuronal loss is found in the neostriatum, globus pallidus, cerebellum and cortex. Earliest loss is seen in the striatum, where up to 95 percent of neurons may be lost in advanced cases. Glucose metabolism is reduced in the striatum (especially the caudate nucleus), which suggests that this altered metabolism may be associated with neuronal loss in the neostriatum (Carter *et al.* 1989).

Treatment

There are hardly any long-term, successful treatments for HD. Current treatment involves the use of dopamine antagonists (e.g. sulpiride, tetrabenazine, perphenazine), which bring relief of acute symptoms but still leave bradykinesia. The notion behind most pharmacological interventions is to restore the balance of neurotransmitters in the basal ganglia.

Aetiology

The cause of the degeneration in HD is unknown, although speculation has revolved around the action of a possible toxin that affects cell degeneration. Three of these toxins may be kainic acid, quinolinic acid and glutamic acid. The idea is that these toxins overstimulate cells, which results in the cells' death.

Sydenham's chorea

Sydenham's chorea is a childhood disorder involving the gradual appearance of chorea between the ages of 7 and 12, which subsides between one and four months after onset. This disorder is associated with streptococcal infection, which can precede the disorder by up to six months.

Dyskinesia

Dyskinesia describes a sustained, involuntary contraction of muscles that results in twisting, repetitive movements and abnormal posture. Examples of this type of disorder are the dystonias, motor disorders in which distorted trunk or limbs occur as a result of excessive muscle tone. Generalized dystonia may involve lesions to the basal ganglia, especially the putamen, and is treated by anticholinergic drugs. Focal dystonia, as the name suggests, indicates a motor abnormality specific to a particular part of the body (or a small group of muscles) and is treated with botulinum toxin (BTX). Blepharospasms describe the intermittent or sustained closure of both eyes because of contractions of the orbicularis oculi muscles surrounding the eye. BTX is, again, a successful treatment. Cranial dystonia (Meige's syndrome) is a motor disorder of the masticatory, lower facial and tongue muscles in which there is difficulty in opening and closing the jaw. Cervical dystonia describes the directionless deviation of the head, often leading to a fixed head posture. Neck muscles are the focal muscles affected, and the disorder worsens when the patient walks. Hand cramps, such as those seen in writer's/musician's cramp, result only from the execution of precise, well-rehearsed fine motor movements with the hand. Symptoms are a tight grip and abnormal finger position. Hemifacial spasm describes a dysfunction of the seventh cranial nerve and involves unilateral twitching/spasms in muscles innervated by this nerve. The cause appears to be compression of the nerve by blood vessels.

Gilles de la Tourette syndrome

Gilles de la Tourette syndrome (GTS) is a disorder in which motor and phonic tics occur despite otherwise normal behaviour. The earliest cases were described by Michel Itard and Gilles de la Tourette in the nineteenth century. Onset is usually in childhood (before 15 years), and early symptoms include blinking, grimacing, head jerking and shrugging of the shoulders (Janowic 1993). Phonic tics include sniffing, snorting, the repetition of words (palilalia), echolalia and the uttering of obscenities (coprolalia). From a psychological perspective, the cursive swearing is an important and interesting feature of the disorder because of what it might reveal about the neural basis of uninhibited language use. Coprolalia is present in around 20–50 percent of people with GTS, and this varies across cultures. However, the disorder and the coprolalia appear cross-culturally: it has been reported in the USA, France, Germany, the UK, the Czech Republic, Italy, Poland, Russia, Japan, Hong Kong, Argentina, Brazil, Portugal and Hungary. The swearing occurs in the native language (Van Lancker and Cummings 1999).

One view of the disorder regards it as the result of phonic positioning – the swear words are uttered more frequently because the phonemes in them are common or frequently used. However, this explanation seems unlikely, because the most commonly uttered expletives in American and British English have as their initial sounds, f, k and b (e.g. 'fuck', 'cunt', 'bastard'), which do not represent the most frequently appearing consonants in English (f and k are ranked ninth and fourteenth, for example). Although evidence is mixed, a more plausible explanation may be that the operation of the basal ganglia and its connections with the orbito-frontal cortex is dysfunctional. Abnormalities, including reduced cortical volume and metabolism, have been reported in the globus pallidus, putamen and caudate nuclei in GTS patients (Haber *et al.* 1986; Peterson *et al.*

1993; Eidelberg *et al.* 1997). The neurotransmitter dopamine is also implicated, because neuroleptic drugs that block dopamine D2 receptors reduce the degree of coprolalia and, as you saw in Chapter 2, dopamine projections extend to the frontal cortex from the basal and subcortical regions.

The nature of the language – swearing – and the consequences of frontal cortex damage for social conduct reviewed in Chapter 5 reinforces the association between the frontal cortex, the basal ganglia and inappropriate linguistic/social behaviour. The disorder is normally treated with the drug haloperidol.

Wilson's disease

Wilson's disease, also known as hepatolenticular degeneration, is a genetic disorder in which disturbed copper metabolism leads to a build-up of excessive intracellular copper, causing cell death. Characteristics of the disease are increased copper in the liver, kidney, brain and cornea, atrophy of the striatum, and increased sponginess of the white matter. Most neuronal loss is seen in the striatum and globus pallidus. The behavioural symptoms are very similar to those of parkinsonism, which means that Wilson's disease must be ruled out before a clinical diagnosis of PD can be made. These symptoms include tremor, akinesia, dystonia, chorea and walking difficulties. About half of patients develop liver disease; the other half exhibit these symptoms. One useful diagnostic measure is the detection of the Kayser–Fleischer ring of the cornea of the eye. This is brownish, appears at the innermost layer of the cornea and is symptomatic of Wilson's disease. Wilson's disease tends to affect about three in 100 000. Treatment is aimed at reducing the build-up of intracellular copper.

Motor neuron damage

Examples of motor disorders involving a dysfunction of the motor neurons include muscular paralysis and atrophy such as poliomyelitis, which is caused by a viral infection of the motor neurons of the spinal cord; limb weakness, especially lower limbs or arms, resulting from loss of myelin in motor and sensory tracts such as multiple sclerosis; paralysis of both lower limbs resulting from complete transection of the spinal cord (paraplegia); and paralysis in all four limbs (quadriplegia). Cerebral palsy describes motor dysfunction resulting from foetal brain damage.

Myoclonus

Myoclonus describes brief, sudden, involuntary movements originating from any point in the CNS. Perhaps the most well-known and least disruptive example of myoclonus is the hiccup. Another well-known and not too disruptive example is the orgasm.

Ataxia

Ataxia refers to uncoordinated, involuntary movement associated with cerebellar lesions. Patients may fail to reach an object they are reaching for (dysmetria), or they may oscillate near the object or exhibit tremor during any movement. Patients may overshoot when reaching for an object (hypermetria) or undershoot and fail to reach (hypometria). A well-known example of ataxia is gait ataxia, in which the legs walk in a very broad-based fashion, often giving the impression that the person is drunk. Damage is usually to the medial zone of the cerebellum. Arms are affected by lateral cerebellar lesions. There is also a disorder known as thalamic syndrome, in which unilateral thalamic damage causes contralateral ataxia. Another ataxia, optic ataxia (inability to perform coordinated voluntary lateral eye movements), is also known as Balint's syndrome, referred to in Chapter 6. Finally, Friedreich's ataxia describes a rare, inherited disorder that involves degeneration of the spinocerebellar tracts. In addition to the ataxia, patients often exhibit weakness and abnormal reflexes.

Apraxia

According to Heilman (1979), apraxia is a movement disorder 'defined by exclusion'. It is a 'disorder of skilled movement not caused by weakness, akinesia, deafferentation, abnormal tone/posture or movement disorder'. The term was coined by Steinthal (1871), who used it to describe the inability to make a voluntary action related to object use in the absence of paralysis. Meynert made the distinction between object recognition deficits and deficits affecting action by referring to the former as 'sensory asymbolia' and the later as 'motor asymbolia' (impaired memory for images of movement). Apraxia nowadays describes deficits in skilled voluntary movement that manifest themselves as the omission of actions, or the execution of inappropriate actions in the absence of primary motor system impairment or comprehension impairment. For example, a patient might be unable to butter a slice of bread or brush their teeth in an appropriate (and voluntary) way. Apraxia usually accompanies aphasia (because overlapping frontal left hemisphere regions are lesioned), but aphasia can appear without accompanying apraxia (Papagno *et al.* 1993). Patients are usually anosognosic and will attribute their motor problems to clumsiness. Frequently, however, patients will be anosognosic because they genuinely do not perceive any movement difficulty in everyday life; only when tested under clinical conditions are movement irregularities unearthed.

Liepmann (1900) was one of the first to publish a report of a genuinely apraxic patient, MT. This patient was an 'ambidextrous syphilitic' councillor who was unable to imitate hand position or mime with his right hand but could make spontaneous hand movements and was less impaired with his left hand. Liepmann argued that not only could impairments in voluntary action be distinguished from language impairment and paralysis but also that the disorder was not unitary. His theory argued that apraxia was associated with left hemisphere or callosal damage and that damage to different left hemisphere regions produced different types of apraxia (Liepmann 1920). In most patients, the non-dominant hand is more impaired than the dominant hand. This theory is discussed with other theories a little later on.

Tests of apraxia

Some of the tests used to determine apraxia are listed in Table 7.2. The instructions in these tests normally take the form of oral commands from the experimenter. Included in these are tasks involving gesture to command, where the patient is required to mime tool use and show the experimenter how to use an object, and tasks involving the performance of emblem gestures such as waving goodbye. Both hands are tested. Patients may also be required to imitate behaviour: some patients are able to follow commands but are unable to imitate. Other tests involve requiring the patient to mime the use of a tool on seeing it or to mime the use of the tool that works on a seen object. For example, if the patient sees a nail, he or she will be required to mime the use of a hammer. Actual tool use is tested, as is the comprehension of tool use, i.e. the experimenter will ask the patient what tool is being used in the experimenter's mime.

Types of apraxia

As one might expect from a disorder involving motor behaviour, different parts of the body may be affected in apraxia. Thus disorders are named after the motor behaviour or body part most affected (e.g. construction, gait, buccofacial) and are therefore termed limb apraxia or gait apraxia. There continues to be controversy surrounding the classification of apraxia. Lezak (1995), for example, referred to a collection of disorders called the apraxias utilizing. The terms 'apraxias of symbolic actions' and 'apraxia of the utilization

Table 7.2 Some of the tests used to detect apraxic symptoms

Intransitive limb gestures	Waving goodbye Hitchhiking Saluting Beckoning 'come here' Indicating 'stop' Indicating 'go'
Transitive limb gestures	Opening a door with a key Flipping a coin Opening a screw-top bottle Using a screwdriver Using a hammer Using a pair of scissors
Intransitive buccofacial gestures	Sticking out the tongue Blowing a kiss
Transitive buccofacial gestures	Blowing out a match Sucking on a straw
Sequential movement	Cleaning a pipe, putting tobacco in it and lighting it; folding a letter, putting it in an envelope, sealing the envelope and stamping it

Source: adapted from Heilman and Rothi 1993.

of objects'. Perhaps the most widely used classification system is based on Liepmann's original reports; these distinguish between ideomotor, ideokinetic and ideational apraxia. Other suggested apraxias have been constructional apraxia and dressing apraxia, although it is unclear whether these are disorders in their own right or the consequences of another (visuospatial) disorder. Others have reduced Liepmann's typology to two types: ideomotor and ideational (Tate and McDonald 1995), and these are the two types most frequently reported in the literature. Ideomotor apraxia is principally a disorder in which mimicking or miming an action is impaired; ideational apraxia describes the inability to use many objects in a movement or carry out complex series of movements.

Ideational apraxia

Ideational apraxia refers to the inability to undertake a series of movements involving some ideational or planning component. Objects may be inappropriately used: a patient might try to light a candle by striking a match on it (Pick 1905), for example. Interestingly, De Renzi *et al.* (1968) found a dissociation between the use of the object in the experiment and the use of the object in a natural context. Their patient was unable to use a toothbrush appropriately in the experiment yet was able to use it normally at home. Sequencing errors are manifested in several contexts. For example, when asked to open a can of soup with a can opener, patients have been found to beat the side of the can with the opener (Poeck and Lehmkuhl 1980). Patients are also unable to identify correct and incorrect sequences of gestures in a series of photographs (Poeck 1983). These inappropriate movements have been termed 'parapraxic'. De Renzi and Lucchelli (1988) also found that patients would make omissions in a series of actions, e.g. attempting to pour water from a sealed bottle.

A variant of this disorder has been termed 'conceptual apraxia', characterized by the commission of content errors in making transitive movement, i.e. those that require the use of an object (Leiguarda and Marsden 2000). The most common error is using an object inappropriately, such as the use of a toothbrush as a shaving razor. According to Heilman and Rothi (1997), the disorder reflects a loss of knowledge of the relationship between a tool and its action and between a tool and another object.

Unlike ideomotor apraxia, where the movement problems may not manifest themselves directly in everyday life, ideomotor apraxia can present problems in daily living. Eating breakfast or changing a plug can be problematic, because a patient may choose the wrong tool or object. They may also perform complex movements in the incorrect order.

Ideomotor apraxia

Ideomotor apraxia refers to an inability to mime the use of an object (pantomiming) using simple, single gestures despite normal dexterity (Hecaen 1978) and is the most commonly reported apraxia (Pramstaller and Marsden 1996). There is no ideational component, because individuals are capable of the ideation necessary for the execution of complex movement. Some of the common symptoms of the disorder include incorrectly produced movements executed at an irregular speed and sequencing errors. Patients might use their body parts as objects despite being given repeated instructions not to (Goodglass and Kaplan 1983; Leiguarda and Marsden 2000). For example, when asked to mime using a hammer, patients will use their closed fist as a hammer rather than using the hand to hold an imaginary hammer, or they will use their finger to mime brushing their teeth, rather than miming the holding of a brush.

Other apraxias

Limb apraxia (or limb-kinetic apraxia) refers to an impairment in the execution of fine, precise movement. Finger tapping presents extreme difficulty for limb apraxia patients, as does making single repetitive movements, e.g. tapping a stylus alternately on two sides of a line (Wyke 1967) or flipping a coin (Heilman 1975). Making bilateral hand movements that require coordination is also difficult: patients cannot make a fist with one hand and a palm with the other or alternate fist and flat-hand movements (Luria 1966). Imitating meaningless hand positions is difficult (Pieczuro and Vignolo 1967), as is imitating novel hand postures (Lehmkuhl *et al.* 1983).

Oral (buccofacial) apraxia refers to impaired ability to make oral and guttural movements and was first reported by Hughlings-Jackson (1870), whose patient was unable to cough or stick out her tongue when asked to but was able to do so when eating normally.

Constructional apraxia refers to an impairment in the organization of complex spatial actions such as piecing together a jigsaw, drawing a clock face, copying designs and simple/complex geometrical shapes and building bridges or towers with blocks. Understandably, interpreting the results of such tasks is difficult, because there are individual differences in people's constructional skills.

Cerebral basis of apraxia

The earliest suggestion of cortical involvement in apraxia was made by Liepmann (1900; Liepmann and Maas 1907). Liepmann's hypothesis argued that the left hemisphere's language area had been disconnected from the motor area of the right hemisphere that controls fine movement in the left hemisphere (remember that the cerebral control of movement is contralateral). This disconnection was the result of a callosal lesion. The theory suggested that the left hemisphere contained hand 'movement formulas' that were responsible for controlling purposeful movements and that were disconnected from the right movement areas after callosal lesions. The evidence for this hypothesis is fairly mixed: Gazzaniga *et al.* (1967) found no evidence for the theory, although Watson and Heilman's (1983) patient failed to imitate and use objects. Heilman and Rothi (1993) suggest that the difference may have been due to variability in brain organization.

Almost all cases of apraxia in right-handed patients involve left hemisphere damage (Geschwind 1965), which might explain the incidence of language difficulty in apraxia, and symptoms are more severe after anterior than posterior damage (Basso *et al.* 2000, 2002). Left frontal and parietal lobe lesions have also been associated with impaired performance on unfamiliar sequence tasks (Kimura 1982; De Renzi *et al.* 1987), with left parietal lesions associated with impairments in producing meaningful gestures (Hecaen and Rondot 1985). Gait apraxia has been associated with bilateral frontal lesions. Damage to the anterior left hemisphere, especially the left central operculum and insula, has been found in cases of oral apraxia (Tognola and Vignolo 1980). Constructional apraxia appears to be a right hemisphere, especially right parietal, disorder, although there are task differences. Left-lesioned patients oversimplify the shape of a cube, for example, whereas right-lesioned patients do not (Arrigoni and De Renzi 1964). Perhaps constructional apraxia has two dissociable elements – the right hemisphere shows impairment in the processing of spatial relationships, whereas the left hemisphere shows deficits in the organization of actions needed to draw.

Although characterized as a cortical disorder, apraxia has also been associated with lesions to the basal ganglia and the thalamus to a greater degree than was previously

thought. In an extensive review of the involvement of the basal ganglia and thalamus in apraxia, Pramstaller and Marsden (1996) found that lesions confined to the basal ganglia rarely caused apraxia (eight out of eighty-two cases). However, apraxia was found to result after lesions in the putamen and associated white matter (fifty-eight out of seventy-two cases) and occurred with thalamic damage in twenty-six cases and minor thalamic lesions in eight cases. The authors conclude that although apraxia cannot result from exclusive lesioning of the basal ganglia, it can result from basal ganglia damage and associated white matter lesions.

Theories of apraxia

Liepmann's theory of apraxia argues that the left parietal cortex (area 40) is the brain region mediating complex movement and proposes that a connection runs from the left parietal cortex to the left frontal cortex via the corpus callosum (Liepmann 1905). This connection, if disrupted, will result in apraxia.

Geschwind's disconnection hypothesis expanded on Liepmann's model by proposing that apraxia resulted from disconnections between motor association pathways (Geschwind 1965). A disconnection between posterior language areas and motor association areas important for implementing motor programmes resulted from lesions to the arcuate fasciculus. However, patients with lesions to this area should still be able to imitate, and the damage does not explain why some patients are gauche in their object use.

Heilman's representational hypothesis argues that the nervous system, because it stores knowledge of motor skills, does not construct a programme for carrying out those skills from scratch (Heilman 1979). Patients with parietal lesions exhibit apraxic symptoms because their 'learned time-space movement representations' or praxicons (the skills to be retrieved) are stored there. These praxicons programme the motor association cortex, which implements the programme by activating the motor cortex. Based on this theory, Heilman and his colleagues (e.g. Heilman *et al.* 1982) have suggested that there may be

Figure 7.1

An illustration of the possible command apparatus of the parietal lobe (from Carlson, Neil, R. *Foundations of Physiological Psychology*, 3rd edition. Published by Allyn and Bacon, Boston, MA. Copyright © 1995 by Pearson Education. Reprinted by permission of the publisher)

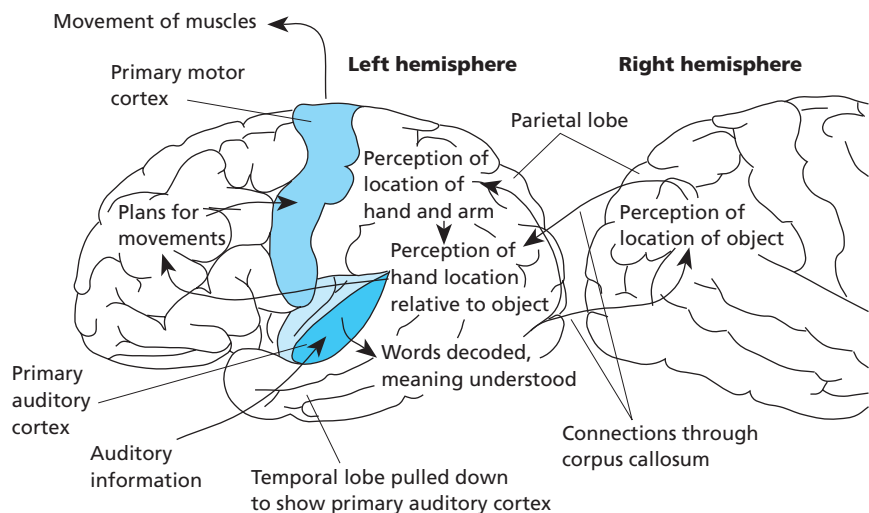

two forms of ideomotor apraxia. The first is the result of praxicon loss in the supramarginal or angular gyrus. The second results from lesions anterior to these areas, which disconnect the praxicons from the premotor and motor association areas or damage the premotor cortex. One model of the command apparatus of the parietal lobe is illustrated by Figure 7.1.

Hemiplegia

Hemiplegia refers to a loss of voluntary motor control on the side of the body contralateral to the damaged side of the brain. Damage is done to the cortex, cerebrospinal fibres and basal ganglia, normally as a result of cerebral palsy (in infants), aneurysm, tumour or head insult (in young adults) and brain haemorrhage (especially in the middle-aged, the group most likely to be affected). The locus of the disease is usually the middle cerebral artery (which supplies blood to the motor area). Once voluntary movement is lost, patients often exhibit muscular spasticity, which results in posture and lower limb movement problems.

Discussion point: can neural transplants abolish the symptoms of Parkinson's disease?

The primary neuropathological characteristic of Parkinson's disease is a reduction in dopamine. Levodopa, the drug treatment of choice for parkinsonism, aims to combat this reduction via replacement. What if, instead of replacing the drug chemically, it was possible to replace the degenerated neural tissue that was responsible for supplying the dopamine?

This treatment strategy has become a practical human possibility in recent years, based largely on work on animals. A large number of experiments have transplanted neural tissue from one animal to another whose tissue had been lesioned to produce cognitive symptoms similar to those seen in Parkinson's disease, Alzheimer's disease and memory disorder. Grafted dopaminergic tissue can survive in the receiving organism and has been found to re-innervate parts of affected brain, especially the striatum, in rats and monkeys (Bjorklund 1992; Winkler *et al.* 2000). Animal work prompted trials with human participants in 1987, particularly patients with Parkinson's disease (PD), where human embryonic nigrostriatal tissue is transplanted into another human brain.

The tissue used is normally tissue obtained from voluntarily or spontaneously aborted fetuses. Like normal tissue, it can send electrical signals and synthesize and release dopamine spontaneously (Olanow *et al.* 1996). One of the earliest studies of the effects of neural grafts in PD patients was undertaken by Lindvall and his colleagues (Lindvall *et al.* 1989). In this study, two PD patients received ventral mesencephalic grafts transplanted into the caudate nucleus and anterior putamen. After six months, there was a small but significant improvement during the 'off' period of the drug treatment. In a second experiment with two other PD patients, younger neural tissue was transplanted into the posterior and anterior putamen. This time, an improvement was seen after six to twelve weeks, and behaviour improved over three years. Bradykinesia was reduced bilaterally, and the reduction in rigidity was more apparent on the side of

the body contralateral to the side of the transplant. PET studies have shown that such transplantation is associated with increased dopamine synthesis and retention in the receiving brain (Nakamura *et al.* 2001; Hauser *et al.* 1999).

Several other studies have shown positive results following foetal neural transplants, although it is often difficult to compare studies because of differences in grafting techniques, the site of the graft, how much tissue is replaced, the lateralization of the graft, patient variability and inconsistencies in follow-up studies. Freed and his colleagues, for example, transplanted unilateral nigral grafts into the caudate and putamen of two patients and bilateral transplants in the remaining five (Freed *et al.* 1992). Substantial improvement was seen after twelve months, with patients achieving 39 percent reduction in their drug treatment. However, Spencer *et al.* (1992) found improvement in patients receiving right caudate grafts but only when compared with their pre-operative condition; patients did not perform better than a control group. Greater improvement appears to result from grafts given to patients whose parkinsonism has been induced by MPTP (Widner *et al.* 1992). In this study, bilateral caudate and putamen grafts in two patients were associated with improvements in motor function three to four months after the transplant.

In their review of neural transplant studies in PD, Olanow *et al.* (1996) suggest that a number of factors can influence the successful outcome of a neural graft. These factors include the age of the donor graft, the number of donors, the amount of tissue grafted, the distribution of the graft, the site of the graft and the type of patient operated on. For example, the optimal age for graft donation is 5½–9 weeks. An older donor is likely to be ineffective. About 500 000 dopamine-containing cells exist in the human substantia nigra, and about 25 000 of these project to the putamen. The PD patient loses approximately 60–80 percent of striatal dopamine, which suggests that a graft that replaces the complete number of dopamine-containing cells is unnecessary. In addition, a graft often contains other neurons, which may be irrelevant to the process that the graft is trying to improve. For human transplants, striatal grafts innervate an area of about 2–5 mm radius. The site of the graft is important, because different regions will project to other, different regions. The best sites for grafts in PD are the putamen and caudate.

Why do grafts work? What is the mechanism for recovery? These are important questions, because different types of graft will show very different outcomes. Animal work, for example, has found that hippocampal grafts in the basal ganglia do not produce an improvement in cognition, whereas cholinergic grafts do. One possible mechanism is that the graft releases a missing neurotransmitter (in PD's case, dopamine). In this sense, grafts provide a 'drug-delivery system' (Sinden *et al.* 1995). Alternatively, the grafts could form reciprocal connections with other regions in a fairly normal manner. A test of this hypothesis would be the transplantation of grafts that secrete the same neurotransmitter but function differently. However, the grafts themselves might secrete the neurotransmitter differently. It is possible that the grafts secrete growth factors, which help to repair the damaged tissue (Sinden *et al.* 1995). At present, it is unclear which of these mechanisms (or others) are responsible for the improvement in cognitive and motor behaviour seen after transplantation.

There may also be a strong placebo effect in recovery, which means that these explanations should be considered with caution (de la Fuente-Fernandez and Stoessl 2002) (see Figure 7.2). Two long-term trials that began in 1993, for example, undertook some sham surgery on a group of patients to explore whether the placebo effect explained the recovery rates – simply the act of having surgery might have produced recovery. In sham surgery, a hole is drilled in the skull, but no tissue is implanted. One of these studies showed no improvement in the experimental group (Freed *et al.* 2001),

Figure 7.2

Motor change scores in PD patients who have received foetal grafts in recent studies: (a) changes in motor behaviour across time in six studies of transplantation; (b) changes in blood flow to the supplementary motor area and dorso-lateral prefrontal cortex across time following transplantation (from Winkler *et al.* 2005)

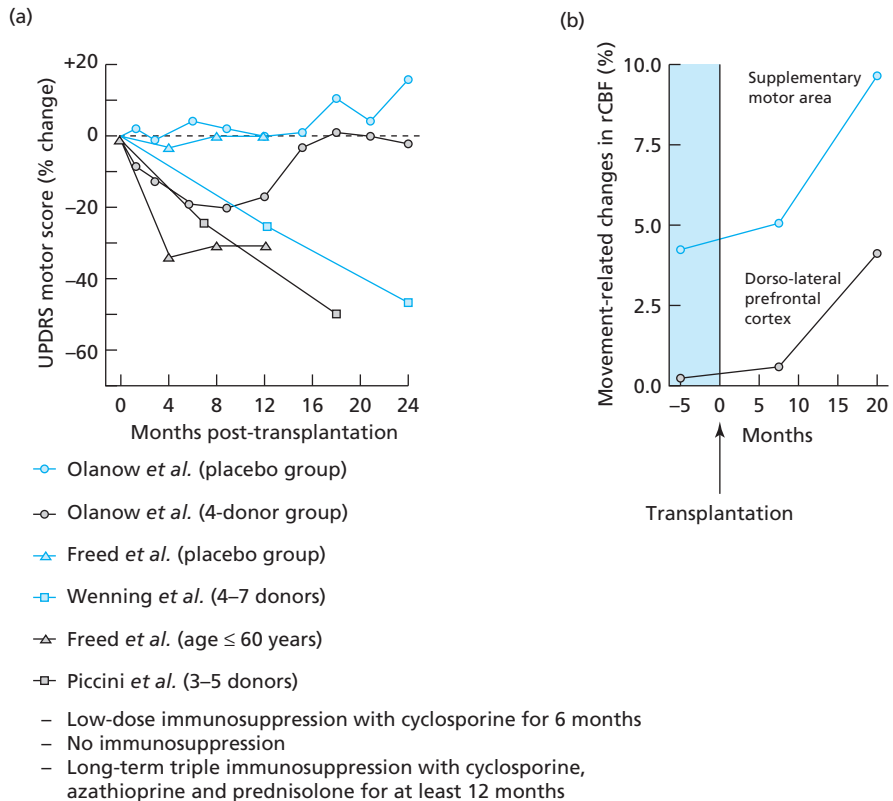

although participants under 60 years of age showed a 30–35 percent reduction in symptoms. The second study followed up patients for two years and reported no significant decline in motor scores, i.e. no improvement (Olanow *et al.* 2003). Four patients showed improvements over six months but then declined to baseline levels at eighteen months. The problem in these two studies appears to have been the absence of immunosuppressant treatment to deal with the inevitable inflammation arising from the graft; in the second study, for example, immunosuppressant drugs were removed at six months, the point at which the improved patients began to show decline (Winkler *et al.* 2005). There may also be what Winkler *et al.* call ‘patchy’ dopaminergic innervation of the putamen, which results in excess dopamine going from re-innervated regions to striatal regions that were not re-innervated. This may cause residual motor impairment.

Parkinson’s disease, perhaps more than Alzheimer’s disease, is the degenerative disorder most likely to benefit from neural transplants, because the system affected is fairly specific and the deficits can be mimicked in animal studies more effectively than can Alzheimer’s symptoms. Currently, however, some groups appear to benefit more greatly than others; the under-60s and those with milder forms of the disease show the best recovery.

Summary

Basal ganglia disorders, also referred to as extrapyramidal disorders, involve symptoms of excessive or restricted motor activity. Parkinson's disease (PD), first described by James Parkinson in 1817, is a motor disorder characterized by loss of movement (akinesia), resisting passive movement (rigidity) and tremor at rest. Early symptoms of the disorder include disturbed fine motor control of the hand. Symptoms of PD are called parkinsonism. The prominent neuropathology is the loss of the striatal dopamine pathway, which runs from the substantia nigra to the caudate nucleus, putamen and globus pallidus. Dopamine is depleted in the basal ganglia, and GABA is reduced in the striatum and substantia nigra. PD is treated effectively by Levodopa (L-dopa), which makes more dopamine available to nigrostriatal nerve endings. Grafting of foetal neural tissue into the parkinsonian brain is a form of treatment that is currently being assessed in the long term as is deep brain stimulation. Huntington's disease is an inherited motor disorder characterized by involuntary, dance-like, jerky movement. It is associated with a mutation of the gene on the arm of chromosome 4. Neuronal loss occurs in the basal ganglia, cerebellum and cortex but is most severe in the striatum. Dopamine agonists are the most commonly recommended treatment, but there is currently no long-term successful treatment. Gilles de la Tourette syndrome describes motor and phonic tics that occur despite otherwise normal motor behaviour. Symptoms include blinking, grimacing, head jerking, sniffing, snorting, repetition of words and uttering obscenities. Apraxia is a motor disorder involving an inability to make voluntary actions to verbal commands. There are various types of apraxia: limb apraxia (impaired precision movement), ideational apraxia (inability to undertake action with a planning or ideational component), ideomotor apraxia (inability to mime the use of an object), gait apraxia (walking difficulty), oral apraxia (inability to make oral or guttural movements) and constructional apraxia (inability to copy, organize spatial relations or build). It is associated with left, usually parietal, hemisphere lesions in right-handers.

Recommended further reading

Parkinson's disease

- Bergman, H., Feingold, A., Nini, A., Raz, A., Slovin, H., Abeles, M. and Vaadia, E. (1998). Physiological aspects of information processing in the basal ganglia of normal and parkinsonian primates. *Trends in Neurosciences*, 21, 1, 32–8.
- Obeso, J.A., Olanow, C.W. and Nutt, J.T. (2000). Basal ganglia, Parkinson's disease and Levodopa therapy. *Trends in Neurosciences*, 23, 10, S1–S126.
- Parkinson Study Group (2004). Levodopa and the progression of Parkinson's disease. *New England Journal of Medicine*, 351, 2498–508.
- Samuel, M. *et al.* (1998). A study of medial pallidotomy for Parkinson's disease: clinical outcome, MRI location and complications. *Brain*, 121, 59–75.
- Winkler, C., Kirik, D. and Bjorklund, A. (2005). Cell transplantation in Parkinson's disease: how can we make it work? *Trends in Neurosciences*, 28, 2, 86–92.
- Youdim, M.B.H. and Rieder, P. (1997). Understanding Parkinson's disease. *Scientific American*, January issue, 38–45.

Apraxia

- Goldstein, L.H. (2004). Disorders of voluntary movement. In L.H. Goldstein and J.E. McNeil (eds), *Clinical Neuropsychology: A Practical Guide to Assessment and Management for Clinicians*. Chichester, UK: John Wiley and Sons.
- Pramstaller, P.P. and Marsden, C.D. (1996). The basal ganglia and apraxia. *Brain*, 119, 319–40.
- Schnider, A., Hanlon, R.E., Alexander, D.N. and Benson, D.F. (1997). Ideomotor apraxia: behavioural dimensions and neuroanatomical basis. *Brain and Language*, 58, 125–36.
- Zadikoff, C. and Lang, A.E. (2005). Apraxia in movement disorders. *Brain*, 128, 1480–97.

8

The neuropsychology of language and language disorders

Nicky Brunswick and G. Neil Martin

The neuropsychology of language: an introduction

The neuropsychology of speech production and comprehension: brain activation in healthy individuals

Universal language areas

The neuropsychology of speech production and comprehension: language disorders

Aphasia

Sensory (Wernicke's) aphasia

Production (Broca's) aphasia

Conduction aphasia

Deep dysphasia

Transcortical sensory aphasia

Transcortical motor aphasia

Global aphasia

Recovery from aphasia

Challenges to the traditional model of aphasia

Specific language functions

Spoken word recognition

Spoken word production

Grammatical representation of words

The production of sentences

Neuropsychology of normal reading

Translating from print to sound

Deriving meaning

Pathways to reading

Discourse

The neuropsychology of reading: dyslexia

Acquired dyslexia

Developmental dyslexia

Neuroimaging and dyslexia

Dyslexia and functional disconnection

Anterior language regions, disconnection and compensation

Developmental dyslexia and neurophysiology

Electrophysiological evidence of anterior and posterior abnormalities

A model of reading, and some neuropsychological evidence

Dysgraphia/agraphia

Phonological dysgraphia

Orthographic (surface) dysgraphia

Deep dysgraphia

Summary

Recommended further reading

The neuropsychology of language: an introduction

Understanding the neural basis of language presents neuropsychology with one of its perennial and most important challenges. Those who take up this challenge generally approach it from one of a number of standpoints: they may study language function in humans (and it usually is humans) with normal cortical development, in humans who have suffered some form of cerebral insult, or in those with abnormal or unexpected language development. By drawing together the findings from these different strands of research, it might be possible to make sense of the neuropsychology of speech production and comprehension, and reading.

The earliest scientific studies of the localization of language were reported in the mid-nineteenth century, as Chapter 1 recounted. The French neurologists Pierre Paul Broca (1861) and Marc Dax (1865) both observed that damage to the frontal region of a patient's left hemisphere resulted in an inability to produce fluent speech. Most famously, this was seen in Broca's patient Leborgne. This patient became known as Tan because this was the only word he was able to produce effortlessly. However, comprehension of language was spared. A *post mortem* revealed that Tan had lesions of the frontal operculum in the frontal lobe. This area subsequently became known as the brain area responsible for language *production* and is called Broca's area. Although this language disorder is called Broca's aphasia, Broca originally described the disorder as 'aphemia'. This type of language disorder was characterized by agrammatisms – there would be a reduction in the complexity of syntax and a reduction or absence of function words (such as prepositions) and inflexional markers (such as past tenses and plurals). Further investigations by Carl Wernicke (1874) demonstrated that damage to posterior regions of the left hemisphere resulted in an inability to comprehend speech, despite unimpaired speech production. Wernicke's MD thesis, *Des Aphasische Symptomencomplex*, is probably the most widely cited and influential student thesis in psychology (Wallesch *et al.* 2002) and, probably, neurology. Wernicke's area, as the damaged region was termed, became known as the area responsible for language *comprehension*. According to Wernicke, the first temporal convolution was the cortical destination of the auditory nerve and the temporal lobe was the region where auditory word 'images' were represented. Curiously, Wernicke illustrated this localization in the right hemisphere (*ibid.*).

As both of these language disorders resulted from damage to the left hemisphere, it was initially thought that the right hemisphere played no part in linguistic processing. As you saw in Chapter 4, this led to the dichotomizing of hemispheric functions, with the left side characterized as mediating verbal, sequential, analytical and rational processing and the right side as mediating non-verbal and visuospatial tasks. However, the view that the right hemisphere plays no part in language is erroneous, although in the majority of people its linguistic role is not as great as that of the left hemisphere.

The lesion studies of the nineteenth century gave rise to what is known as the Broca–Wernicke–Lichtheim model of speech processing: the notion that, generally, language regions in the brain are connected and, specifically, that the auditory representations of language are localized in the left temporal cortex, in Wernicke's area, and that the motor representations of such words are localized in the left frontal cortex, in Broca's area. Superficially plausible, neurally attractive and psychologically persuasive, the model was to be radically challenged in the 1970s and 1980s with the reporting of case studies that undermined this ostensibly appealing but apparently simplistic cleaving of the neuro-anatomy of speech processing. These studies are returned to later in the chapter.

The neuropsychology of speech production and comprehension: brain activation in healthy individuals

In a pioneering study, Petersen *et al.* (1988) reported a bilateral increase in blood flow in the primary and secondary sensory areas during the passive perception of spoken words but bilateral activation in the sensory and motor face areas and supplementary speech regions when speech was produced.

Others have observed increased blood flow in the left inferior and middle frontal cortices during performance of a lexical decision task and in the temporal region of the left hemisphere during reading (Price *et al.* 1994; Wood *et al.* 1991; Flowers *et al.* 1991). There is also increased activation in the left frontal cortex during the passive perception of real spoken words but not pseudowords (Petersen *et al.* 1990).

The ability to localize the brain region responsible for putting together sounds to form meaningful words, part of a process called phonological processing, has presented imaging studies with problems. For example, studies have shown increased activation in the left frontal cortex near Broca's area when participants were required to perform a number of tasks, including (1) discriminating between spoken words on the basis of phonetic structure (Fiez *et al.* 1995); (2) monitoring phonemes and discriminating between consonants (Zatorre *et al.* 1996); and (3) making phonological similarity (rhyme) judgements and undertaking phonological short-term memory tasks (Paulesu *et al.* 1996). Zatorre and colleagues have argued that these findings illustrate the importance of Broca's area to the extraction and manipulation of the phonetic segments of speech (Zatorre *et al.* 1992a).

Frontal activation has not been a consistent finding, however. Others have reported increased blood flow in the left temporal lobe during reading. Nobre *et al.* (1994), for example, observed activation in the posterior fusiform gyrus of the inferior temporal lobe during the reading of words and pseudowords, while the anterior fusiform gyrus was active when the semantic context in which the words and pseudowords were presented had to be considered. Similarly, Gur *et al.* (1994) found increased blood flow in the left hemisphere's angular gyrus during the detection of verbal analogies. In this paradigm, participants are presented with a target word followed by two alternative words, one of which is associated in some way with the target; the task is to identify the analogous word. On the basis of this evidence, it has been argued that activation of Broca's area occurs when phonetic manipulations of language are required but that activation of the posterior temporal cortex occurs when speech has to be analysed perceptually (Zatorre *et al.* 1996). Support for this suggestion comes from studies in which activation in both frontal regions (Broca's area) and temporal regions (Wernicke's area) of the left hemisphere are observed in normal readers during the performance of rhyming and short-term memory tasks (Paulesu *et al.* 1996). The regions highlighted by neuroimaging as being involved in language processing were illustrated in Figure 4.1 (Chapter 4).

Event-related potential (ERP) studies have also implicated the left hemisphere in the processing of language (Segalowitz and Berge 1995). For example, studies in which participants were required to articulate a series of letter strings covertly report larger N100 and P200 amplitudes over the left hemisphere than over the right hemisphere (Papanicolaou *et al.* 1983). The N100 and P200 are potentials thought to reflect early sensory processing. Similar asymmetries have been observed during the perception of nonsense words (Segalowitz *et al.* 1992) and consonant–vowel (C–V) phonemes (Brunswick and Rippon 1994) and performance on a phonological task in which the participant is required to name letters that rhyme with 'v' (Taylor 1993).

Lateralized effects have also been observed for the P300, the ERP component thought to reflect cognitive processing. For example, there is evidence that greater left than right hemisphere involvement is found during reading (Johnstone *et al.* 1984), during the rhyme task described above (Taylor 1993) and during the discrimination of words beginning with stop consonants, e.g. /b/, from those that do not, e.g. /d/ (Taylor and Keenan 1990).

Finally, one other late, negative ERP component, the N400, has been found to be associated with 'receptive language function', that is, the process of attributing meaning to sentences (Connolly and Phillips 1994; Nobre and McCarthy 1994, 1995). Studies have localized semantic processing in the frontal and fronto-central regions of the brain during the passive perception of auditorily presented sentences. Connolly and Phillips (1994), for example, presented participants with spoken sentences in which the final words were either semantically appropriate (e.g. at night the old woman locked the door) or semantically inappropriate (e.g. the dog chased our cat up the queen). They observed an N400 wave, especially at frontocentral regions, only in response to the semantically inappropriate sentences, not to those sentences with semantically appropriate endings. In this context, it is suggested that the N400 reflects a disturbance in the individual's 'online and continuous' processing of speech that bestows it with coherent meaning.

Universal language areas

Bilingualism refers to a proficiency in two languages. The second language may be a native language – children may be reared bilingually – or it may be learned later in life. Bilingual language processing, like single-language processing, is thought to involve left hemisphere regions, but some researchers suggest that the right hemisphere may be more important in the development of a second language. For example, bilinguals with right hemisphere lesions have been found to show a greater degree of aphasia than do bilinguals with left hemisphere lesions (Hakuta 1986).

However, neuroimaging studies suggest more left hemisphere involvement in bilinguals and that similar cortical areas may be recruited during the processing of both languages. For example, a study of French and English speakers found that performing language tasks in both languages was associated with activity in the left inferior frontal cortex (Klein *et al.* 1995). Another study found that there was activation in different parts of Broca's area when people performed language tasks using a language learned in adulthood but that this activation was absent in those who had learned the language in childhood (Kim *et al.* 1997). There was no differential activation in Wernicke's area.

Some researchers have argued that such differences might reflect participants' proficiency in using language rather than the age at which the second language was acquired (Perani *et al.* 1998). If there is an overlap in the language areas that mediate both tongues, this may be due to the similarity of the two languages spoken. For example, most studies have studied bilinguals who speak Indo-European languages (English, French, German and so on). Perani *et al.* (1995) compared brain activation in Italian–English speakers, where English was learned later in life, and Spanish–Catalan speakers, where Catalan was learned concomitantly with Spanish. Focal activity in the left hemisphere language regions was determined by expertise and not age of acquisition, a finding that has been replicated (Chee *et al.* 1999; Dehaene *et al.* 1997). Would the same overlap be seen if the

two languages spoken differed in terms of syntax (meaning and grammar), morphology (physical construction of the language) and phonology (the sound of the language)?

To test this hypothesis, Klein *et al.* (1999) measured cerebral blood flow in seven native speakers of Mandarin Chinese who had acquired English during adolescence. Mandarin uses tone in a way that English does not. The participants' task was to repeat words in Mandarin and English and to generate a verb in response to a noun in Mandarin and English. All words were presented auditorily, and participants were asked to respond vocally. Klein *et al.* found that an area in the left frontal cortex was activated during speech production in Mandarin and English. A similar area was found to be active during French and English language processing in a previous study by Klein *et al.* (1995). Such findings can even extend to speakers of four or more languages. Breillmann *et al.* (2004), for example, used fMRI to measure the response of six quadrilingual participants who were asked to generate appropriate verbs to nouns; if the word 'fish' was presented, the participant might respond with 'swim'. Participants had knowledge of four or five common languages (English, German, Italian, French or Spanish) and completed the verbal task in each of their languages. As previous studies would predict, the task was associated with left-sided activation but, curiously, this activation was more pronounced in the languages in which participants were least proficient. This suggests that when people speak languages in which they are proficient the brain expends less energy – the process is more automatic and requires fewer cognitive resources for this reason. If people are not proficient in a language, there has to be a greater attempt at producing and understanding that language; this in turn recruits greater neural resources in order for the process to succeed.

A recent study has examined whether event-related potentials could distinguish between adults showing 'normal' or 'high' language proficiency (Weber-Fox *et al.* 2003). Ten women and nine men read two types of sentence for sense. One type of sentence did make sense; the second did not because the last word was grammatically correct but made no sense in the context of the sentence. For example, 'The boy put the worm on the hook' made sense, but 'She looked at her watch to check the rain' did not.

While the ERP results showed that there was no difference between normal and highly proficient language users during the early, sensory stages of language processing, there were significant differences in the later stages of processing. The latency of late ERP waveforms was shorter in the frontal left hemisphere region in the highly proficient adults. The amplitudes of very late waves, thought to reflect semantic processing and the processing of the context in which a word appears, were shorter in the highly proficient group, which suggests that this group perhaps engages less in the processing of the context in which a word appears: their proficiency leads them to make such contextual decisions more easily. Children have higher-amplitude late ERPs than do adults, and this high amplitude decreases with age, suggesting that as people become more proficient language users they need to spend less time and effort on processing word context.

The findings reviewed here suggest that there may be universal language areas that allow the processing of morphology, phonology and orthography regardless of the type of language spoken but that the degree of activation may depend on proficiency rather than age of acquisition. However, these studies have observed bilingual speakers and have not directly compared monolingual speakers.

When psychologists talk about the localization of language, it is easy to forget that language is not a standard, unitary process but that it is heavily culture-bound. English and Russian, for example, have different orthographic and phonological rules. In English, there are 1120 ways of using graphemes (letters and strings of letters) to form forty

sounds (phonemes). Italian, on the other hand, has thirty-three graphemes, sufficient to represent twenty-five phonemes. Some authors have suggested that this explains the differences in word-reading speed in English and Italian individuals (Italians are faster).

In two PET studies, Paulesu *et al.* (2000) asked six English and six Italian university students either to read aloud words and non-words (experiment 1) or to perform a feature detection task (experiment 2), which involved paying attention to physical aspects of words presented visually rather than to the words themselves. They were not asked to read the words in experiment 2. The authors found that, across both experiments, the Italian speakers showed greater activation in those areas responsible for processing phonemes (left temporal regions), whereas the English speakers showed greater activation in other areas of the temporal cortex and frontal cortex (areas activated during word retrieval and naming). Figure 8.1 shows some of the areas activated. This study was the first to show cultural effects on brain function related to language in healthy individuals and suggests that the neurophysiological difference may underpin the behavioural findings from word-reading speed studies.

The result is in keeping with studies of aphasia patients among different ethnic Chinese groups. Yu-Huan *et al.* (1990), for example, have reported that unilateral stroke leads to greater incidence of aphasia in dextrals with right-sided lesions (crossed aphasia), but only among the majority ethnic group, the Han. Crossed aphasia is rare among one minority ethnic group (the Uighur-Kazaks), and Wernicke's aphasia is generally rare in the Han. One explanation for this dissociation may lie in the way in which the languages of the groups differ: the Uighur-Kazak language is Indo-European and phonological in nature; the Han language, conversely, is non-phonetic ('ideographical'), and one sound can have multiple meanings.

A similar distinction is found in Japanese. Phonetically based symbols (*Kana*) and logographic symbols (*Kanji*) are used routinely in written Japanese. Left-sided lesions are associated with impaired *Kana* reading in Japanese participants but preserved *Kanji* reading (Sasanuma 1975). When healthy individuals are exposed to the different symbols in a typical visual field experiment, a left visual field advantage for *Kanji* is reported, suggesting right hemisphere involvement (Elman *et al.* 1981).

Figure 8.1

The regions of the brain activated in English and Italian speakers by reading. The differential activation is thought to reflect different reading strategies (from Fiez 2000)

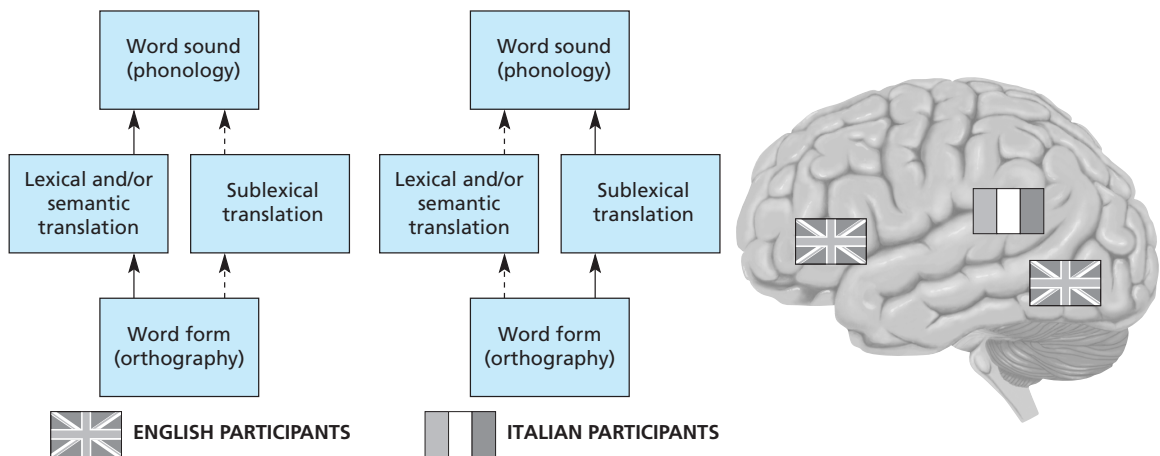

The neuropsychology of speech production and comprehension: language disorders

Normal language processing is the result of a complex interaction of sensory, motor and memory processes. Impairments in any of these processes can lead to language disorders such as aphasia (a disturbance in the comprehension or production of speech), dysgraphia (impaired writing) or dyslexia (disordered reading). The focus of the remainder of the chapter will be on these three disorders.

Aphasia

The term ‘aphasia’, although literally meaning ‘complete loss of language’, may be more accurately labelled dysphasia (meaning a ‘partial lack of language’), because patients with aphasia-producing brain damage generally retain some degree of linguistic ability. Despite the misnomer, however, the term ‘aphasia’ remains that most widely used to describe the loss of language function.

Specifically, aphasia refers to disturbance in the comprehension or production of spoken, written or signed language. It is estimated that approximately 85 percent of cases of aphasia are the result of cerebrovascular accidents (strokes) in the language areas of the brain. Other causes include tumours, organic brain disease and head injuries. A diagnosis of aphasia is made only in the absence of sensory impairments (poor vision or hearing), perceptual impairments (agnosia), impaired movement (apraxia) or thought disturbances (autism, dementia or schizophrenia, for example). This condition is thought to represent a breakdown in the link between thought and language (Mesulam 1990).

A number of attempts has been made to classify the different features of aphasia by associating the symptoms displayed with the locus of the cerebral lesion. This has proved difficult for three reasons: (1) few patients have been studied in any great detail; (2) lesions are rarely found in identical locations or restricted to discrete regions; and (3) the production and comprehension of language depends on a complex and dynamic interaction between numerous regions of the brain, sometimes extending over vast areas of the cortex and the subcortex. Attempts to localize aphasic symptoms to particular regions of the brain are therefore problematic. As Hughlings-Jackson noted in 1874: ‘to locate the damage which destroys speech and to locate speech are two different things’.

In spite of such problems, however, numerous subtypes of aphasia have been described, each with its own specific cluster of symptoms and each produced by damage to a particular cortical region. These regions are generally found in the left hemisphere and are usually perisylvian, i.e. near the Sylvian fissure. Structures including Broca’s area, Wernicke’s area, Heschl’s gyrus, the planum temporale, the supramarginal, angular and temporal gyri, and the frontal gyri have all been implicated in the processing of language and aphasia. These regions are illustrated in Figures 8.2 and 8.3.

The symptoms and regions of damage of the main types of aphasia (sensory, production, conduction, deep, transcortical sensory, transcortical motor and global) are summarized in Tables 8.1(a) and (b) and are described more fully below.

Figure 8.2 The regions of the brain implicated in language processing

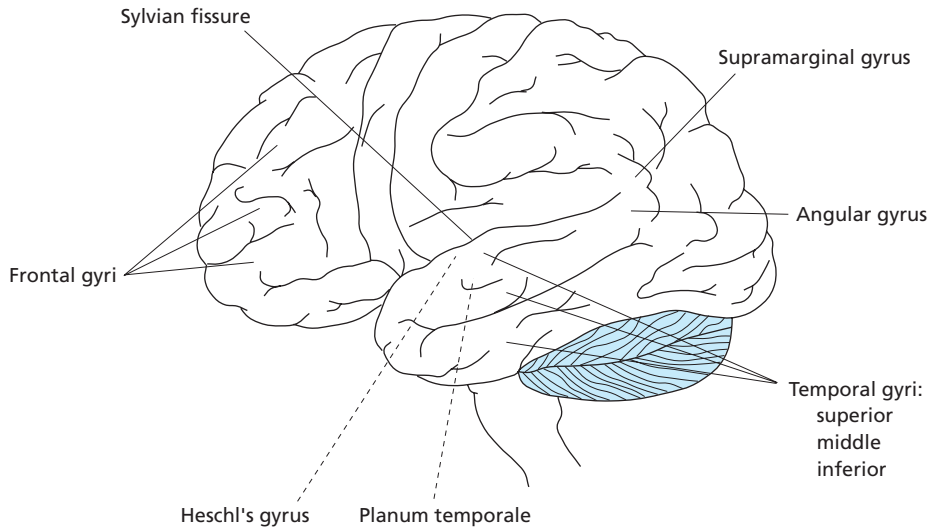

Figure 8.3 The areas of the brain implicated in aphasic symptoms

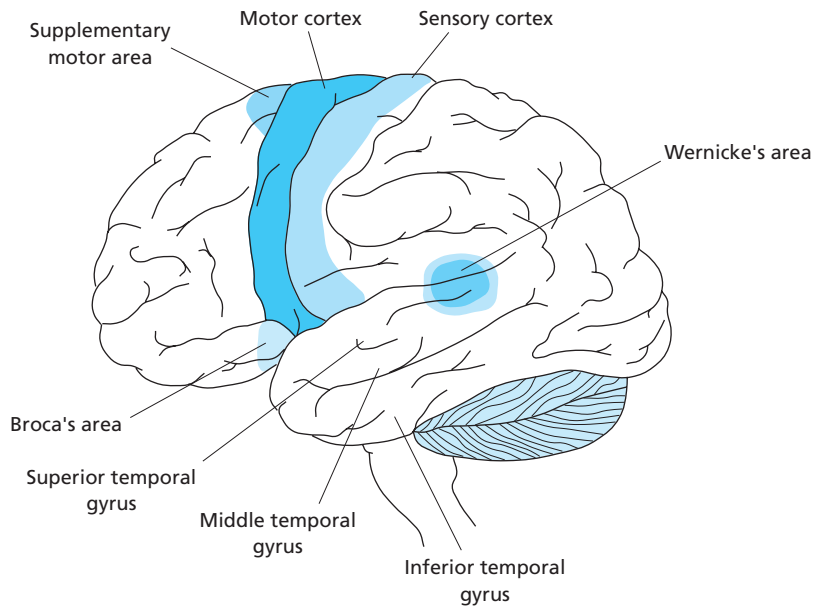





Table 8.1(a) Types of aphasia, their primary symptoms and the possible site of the associated brain lesion

Type of aphasia	Primary symptoms	Brain lesion to
Sensory (Wernicke's) aphasia	General comprehension deficits, neologisms, word retrieval deficits, semantic paraphasias.	Posterior perisylvian region; postero-superior temporal, opercular supramarginal, angular and posterior insula gyri; planum temporale.
Production (Broca's) aphasia	Speech production deficits, abnormal prosody, impaired syntactic comprehension.	Posterior part of the inferior frontal and precentral convolutions of the left hemisphere.
Conduction aphasia	Naming deficits and impaired ability to repeat non-meaningful single words and word strings.	Arcuate fasciculus; posterior parietal and temporal regions: left auditory cortex; insula; supramarginal gyrus.
Deep dysphasia	Word repetition deficits; verbal (semantic) paraphasia.	Temporal lobe, especially regions which mediate phonological processing.
Transcortical sensory aphasia	Impaired comprehension, naming, reading and writing; semantic irrelevancies in speech.	Temporo-parieto-occipital junction of the left hemisphere.
Transcortical motor aphasia	Transient mutism and telegraphic, dysprosodic speech.	Connection between Broca's area and the supplementary motor area; medial frontal lobe; regions anterolateral to the left hemisphere's frontal horn.
Global aphasia	Generalized deficits in comprehension, repetition, naming and speech production.	Left perisylvian region, white matter, basal ganglia and thalamus.

Table 8.1(b) Symptomatology of aphasia

Type	Site of damage	Spontaneous speech	Comprehension	Paraphasia	Repetition	Naming
Broca's		Non-fluent	Good	Common	Poor	Poor
Wernicke's		Fluent	Poor	Uncommon	Poor	Poor
Conduction		Fluent	Good	Common	Poor	Poor
Global		Non-fluent	Poor	Variable	Poor	Poor

Sensory (Wernicke's) aphasia

Sensory or Wernicke's aphasia is a general inability to comprehend speech produced by other people or oneself. While language production is generally fluent, with no articulatory problems, the words produced are occasionally jargon-like. For example:

'Well this is . . . mother is away here working her work out o'here to get her better, but when she's looking, the two boys looking in other part. One their small tile into her time here. She's working another time because she's getting, too.

(Cookie theft picture description from Carroll, D. (1999) *Psychology of Language*, third edition, Brooks/Cole Publishing Company)

Or this example of a conversation between a patient and a speech therapist:

Therapist: What did you have (to eat)?

PH: Today I haven't touched a/maiwa/d/David. He had beastly tomorrow.

Therapist: Was the food good?

PH: Yes, it was fine.

(From R.C. Martin 2003)

The failure of patients with Wernicke's aphasia to comprehend their own speech typically renders them unaware of their language-processing problems, and they will continue to participate in conversations, nodding in the appropriate places and taking turns to speak, blissfully unaware of their disorder.

Wernicke's aphasia is associated with lesions to the first and posterior part of the second convolutions of the superior temporal gyrus adjacent to Heschl's gyrus (part of the auditory association cortex), and the planum temporale in the left hemisphere (Naeser *et al.* 1981; Zatorre *et al.* 1992a). This region has been suggested as the locus of memory for the constituent sounds of speech and is thought to mediate the linking of the auditory representations of words with their meanings. The clinical findings are complemented by imaging studies, which show increases in activation in Wernicke's area during the performance of language tasks with a semantic component (Petersen *et al.* 1988), while object naming is associated with a spread of neural activity from Wernicke's area to the frontal motor systems responsible for activation of the muscles in the production of speech (Damasio and Damasio 1992).

While the problems experienced by patients with Wernicke's aphasia are essentially sensory, involving 'semantic-lexical' aspects of linguistic processing, problems at the more elemental 'syntactic-articulatory' (Bradshaw and Mattingly 1995) level of linguistic processing are characteristic of patients with Broca's aphasia.

There has been some debate concerning the unity of Wernicke's area. Richard Wise and colleagues from Hammersmith Hospital, London, and Addenbrooke's Hospital, Cambridge, for example, have suggested that the term 'Wernicke's area' has become a meaningless concept, with different research groups delineating the area in different ways and imputing different functions to it (Wise *et al.* 2001). The area has been described in such broad terms as to make its use dubious.

To determine whether the area identified as Wernicke's area performed consistent functions, Wise and his group reanalysed four brain-imaging studies of Wernicke's area, identified generally as 'the left superior temporal cortex posterior to the primary auditory cortex'. The reanalysis identified two regions within 'Wernicke's area' that seemed to perform different functions. One part responded to speech and non-speech sounds, including

the sound of the speaker's voice. The posterior part of this, near the parietal lobe, was active during speech production. The second part identified was more lateral and responded to external sources of speech; it was also active during the recall of word lists.

The authors suggest that the function of both parts are compatible with a hypothesis that states that the first region is involved in mimicking sounds and the second is involved in the transient representation of heard or internally generated phonetic sequences. Both processes, the authors argue, are important for the long-term memory of novel words.

Production (Broca's) aphasia

Production or Broca's aphasia is also called non-fluent aphasia, expressive aphasia or motor aphasia and describes difficulty in the production of language. This ranges from a complete inability to speak to the ability to produce speech only with considerable effort. Speech, when it is produced, is typically non-fluent, slow and laboured, although language comprehension at a simple level remains fairly normal. For example:

Doctor: Why did you come to the hospital?

Patient: Ah . . . Monday . . . ah dad and Paul . . . and Dad . . . hospital. Two . . . ah doctors . . . and ah . . . thirty minutes . . . and yes . . . ah hospital. And er Wednesday . . . nine o'clock . . . doctors. Two doctors . . . and ah . . . teeth. Yeah . . . fine.

(Goodglass 1976)

This example shows that the speech of the patient with Broca's aphasia is characterized by extreme verbal economy, by an omission of prepositions and definite articles, by little grammatical construction – it is 'telegrammatic' – and by abnormal prosody. While patients have unimpaired semantic comprehension, their understanding may be impaired by syntactic ambiguities. The sentence 'The dog ate the bone' would not cause a patient with Broca's aphasia any problem, for example; the bone can be eaten by the dog, but the dog cannot be eaten by the bone. A more syntactically ambiguous sentence, such as 'The dog chased the cat', may not be so easily understood; the cat can chase the dog as easily as the dog can chase the cat. Unfortunately for such patients, insight into their linguistic abilities is preserved: they know that they make mistakes, but they cannot correct them.

Neurological examination of patients with Broca's aphasia reveals atrophy of the posterior part of the third frontal with the adjacent part of the second frontal and precentral convolutions of the left hemisphere (Benson 1967; Mazzocchi and Vignolo 1979). This region, which is anterior to the motor cortex, specifically the region of the motor cortex responsible for facial movements, is labelled Broca's area. Ironically, however, it was Wernicke (1874) who explained the association between the cortical damage of patients with Broca's aphasia and their symptoms. He suggested that sensory experiences are stored in the cortical regions adjacent to the areas responsible for those functions. As Broca's area is situated adjacent to the region of the motor cortex responsible for the movements of the mouth, damage to this region will result in destruction of the memory traces of the movements required to produce speech.

The severity of the articulatory disturbances following damage to Broca's area is far more variable than that of the language disturbances that result from lesions to Wernicke's area. While lesions to Broca's area produce transient impairments in speech production, subcortical damage is necessary before a persistent deficit in speech production emerges (Mohr *et al.* 1978).

A wealth of evidence indicates that the production and comprehension of language are mediated by a complex interaction of processes residing in different cerebral regions. Evidence from neural imaging studies has shown that numerous regions are activated simultaneously during language processing. It may be expected, therefore, that damage to the pathways connecting these regions would impair an individual's ability to repeat verbally presented words. In fact, this suggestion was first proposed by Wernicke in 1874. Such a deficit is called conduction aphasia.

Conduction aphasia

Patients with conduction aphasia display apparently normal speech comprehension and production, but impaired naming ability and deficits in the repetition of non-meaningful words and word sequences. Wernicke reported two such patients in his MD thesis. The ability to repeat colloquialisms and stock phrases can be preserved in patients with this subtype (Goodglass 1993). The following exchange occurred between a doctor and patient when the patient was asked to repeat what the doctor was saying:

Doctor: Bicycle.
 Patient: Bicycle.
 Doctor: Hippopotamus.
 Patient: Hippopotamus.
 Doctor: Blaynge.
 Patient: I didn't get it.
 Doctor: Up and down.
 Patient: Up and down.
 Doctor: Yellow, big, south.
 Patient: Yellen . . . Can't get it.
 (Carlson, 1986)

As with patients exhibiting Broca's aphasia, patients with conduction aphasia are aware of their language problems and will often make attempts to correct their errors. If presented with alternative pronunciations, patients are generally able to reject obviously inappropriate alternatives and will often accept the correct ones; this is taken as indicating that the phonological processing skills of these patients are intact and that the problem is confined to the process of retrieval (Goodglass 1993).

Once again it was Wernicke (1874) who offered an explanation for this disorder by suggesting that disconnection of the arcuate fasciculus, the bundle of fibres that connects Broca's and Wernicke's areas, would impair the ability to repeat heard words. Support for this hypothesis comes from Damasio and Damasio's study in which patients with conduction aphasia were found to have damage to the association fibres of the inferior parietal lobe, which normally connect Wernicke's and Broca's areas (Damasio and Damasio 1980). This type of aphasia is also found in patients with lesions of the posterior parietal and temporal regions and sometimes the second transverse gyrus (Hoelt 1957).

Geschwind (1965) has suggested that when a patient with conduction aphasia hears a word (e.g. 'bicycle'), the patient produces a mental representation of the object described by the word. Information concerning this image is then sent from the visual association cortex to Broca's area (thus bypassing the damaged arcuate fasciculus) in order to initiate the movements necessary to produce the sounds that constitute the word. However, such a strategy is effective only for the repetition of meaningful words and phrases. If the

perception of a non-word fails to produce a visual image, the patient is unable to reproduce the word.

Deep dysphasia

A rarer form of aphasia, deep dysphasia, is characterized by the replacement of verbally presented target words by semantically related words. For example, when asked to repeat the words 'kite' or 'shell', the patient who is deeply dysphasic may respond with 'balloon' or 'kernel' (Goodglass 1993). The accuracy of the repetition depends on the class of word used. Concrete nouns are more likely to be repeated correctly than are abstract words; nouns are repeated with greater accuracy than verbs; and non-words are rarely repeated correctly.

Deep dysphasia may result from lesions to the temporal lobe. As discussed above, the temporal lobe is strongly implicated in the processing of language and in phonological memory. It is this latter role that may account for the impairments of patients with deep dysphasia. Patients often report that they have forgotten the actual word presented, although they retain the general meaning. This may be used to guess, often incorrectly, the target word.

Transcortical sensory aphasia

Transcortical sensory aphasia describes the inability to comprehend, name, read and write despite the unimpaired recitation of previously learned passages (e.g. poems or prayers) and repetition. Speech is spontaneous and fluent but semantically irrelevant, as in Wernicke's aphasia. The difference between patients with Wernicke's aphasia and transcortical patients with sensory aphasia is that those with the transcortical variant can repeat words and non-words spoken to them and can correct grammatical errors in spoken phrases. It is suggested that this preserved repetition ability is phonologically rather than lexically based, i.e. words and non-words to be repeated are treated as a collection of sounds (phonological elements) rather than as meaningful wholes (Kertesz *et al.* 1982).

This type of aphasia can result from destruction of the temporo-parieto-occipital junction in the dominant hemisphere. This disconnection of Wernicke's area from the remaining parietal association areas weakens the control of the auditory regions over those mediating speech production, although the arcuate fasciculus may remain intact. The effective isolation of the sensory language areas from the remaining cortex of the dominant hemisphere prevents the transfer of information from the non-language regions to Wernicke's area for encoding into their verbal representations (*ibid.*).

Transcortical motor aphasia

Transcortical motor aphasia, the motoric counterpart of transcortical sensory aphasia, results from the disconnection of Broca's area from the adjacent supplementary motor area. Aphasia-producing lesions have been reported in the left hemisphere regions anterolateral to the frontal horn (Damasio 1981) and in the medial frontal lobe, including the supplementary motor area (Freedman *et al.* 1984). Symptoms are similar to those seen in Broca's aphasia – transient mutism followed by non-fluent, dysprosodic, telegraphic speech. Repetition, object naming and comprehension are spared (see Berthier *et al.* 1991), but right-sided motor impairments may also be seen (Benson 1993).

Global aphasia

Perhaps the most debilitating form of aphasia, global aphasia describes a generalized inability to (1) comprehend or repeat heard speech, (2) produce speech, or (3) name objects. However, the production and comprehension of automatic phrases and word sequences such as days of the week, expletives and greetings may be spared. Global aphasia results from extensive lesioning of the brain, including the left hemisphere's perisylvian region, white matter, the basal ganglia and the thalamus. Damage to these regions also produces right-sided sensory and motor impairments.

Recovery from aphasia

Intensive speech therapy is frequently employed to redevelop the language-processing skills lost in aphasia, and many patients are able to recover to some extent (Kertesz 1993). Aetiology of the aphasia, time of onset, initial severity and size and location of the lesion are the most important factors in prognosis. Severe production, sensory and global aphasias generally improve very little, while dissociative speech disorders tend to improve rapidly and often completely (Adams and Victor 1993). Approximately one-third of aphasic patients recover fully within the first three months; thereafter the possibility of full recovery diminishes such that complete recovery of language is unlikely after six months (Kertesz 1995). Exactly how recovery is achieved is not fully understood, however. One possibility is that cells in the regions adjoining the damaged parts of the brain may regain some of their linguistic-processing abilities; alternatively, it is possible that unaffected regions of the brain (possibly corresponding regions in the right hemisphere) may gradually learn to compensate for the affected regions (Blumstein 1981). Some of the variables affecting the recovery of function are discussed in Chapter 13; the box describes and examines some of the personal and longitudinal consequences of aphasia.

The man who lost his language: the phenomenology of aphasia

On Tuesday, 28 July we went to a party in London. I drove home because John had had too much to drink. At a red light I glanced at him, and saw on his face the expression of a man crazed by an apocalyptic vision. He laughed it off: 'Is that what you go around saying at parties, "Good evening, you have a crazed apocalyptic look on your face?"' If I had known what that look meant, it is theoretically possible that I might have saved him ...

SHEILA HALE (2002), *THE MAN WHO LOST HIS LANGUAGE*, p. 30

On the morning of 30 July 1992, just before nine o'clock, Sir John Hale, the well-regarded art historian and prolific author, was found on his study floor, having the 'sweet witless smile of a baby' on his face and uttering only the words, 'the walls, the walls'. Hale had suffered a stroke. Sheila, his wife, had noted one of the signs just days before – a change in the musculature of his face. While most of the studies in this book

emerge from academic journals and are reported in the clinical way that one would expect from such a source, Sheila Hale wrote an account of the disorder and its consequences, writing in careful and often touching detail about the personal fall-out associated with stroke and aphasia and how she coped with the virtual demolition of her husband's language.

Initially, John Hale was unable to speak or write or match written/spoken nouns to objects such as a razor, a chick, a pencil and some keys. He could surmise what people were saying from their gestures and tone of voice, laughing at jokes and following simple instructions. Reading for pleasure was difficult and he would turn over pages he could not follow. Curiously, he could understand academic journals and offprints, which suggested a dissociation between reading for pleasure and reading for information. John was written off by his original consultant – at the time of the stroke, Hale was in his 60s and was felt to be unable to benefit from rehabilitation – but an independent neurologist suggested that his intelligence alone might help his recovery. Sheila Hale discovered a series of language puzzle books designed for Roald Dahl's wife, Patricia Neal – who had become aphasic following a stroke – by Valerie Eton Griffiths and recruited family and friends to use them with her husband. At this point, he began introducing new sounds into his conversation: *the*, *da* or *whoah*. He could copy shapes and words and perform mental arithmetic but was unable to write words independently.

At a new hospital, he was given a pad to write on. One of his earliest spontaneous examples of writing involved writing 'f' in the centre of the page and 'o' 'r' and 'k' diagonally to the right. The speech therapists tried to get him to utter the letter 'p' (one of the easiest), but he was unable to do this. By now, however, he could point to objects and match them to names. Sometimes, he would 'cheat': although appearing spontaneous, some of his writing incorporated words from newspaper stories. On one occasion, he wrote, 'an da rodor wesh rof; rand brinste trab. Refugees from the former Yugoslavia. Blook cridder was drosed. A bracelet of bright haire about the bone. Ah! And the and'.

He could also sort Scrabble tiles into words – often punning with them. He could play Boggle, and he could reconstruct sentences that had been cut up. Proofreading his most recent book, he missed some errors but was able to direct his editor to the location of the references needed for the book.

Shortly after this, a friend of a friend introduced Sheila to Elizabeth, a speech therapist in private practice with a reputation for excellent rehabilitation. To begin with, Elizabeth thought that John could not benefit from therapy – ironically, because he was too exuberant and that anyone with his degree of expressiveness would not be sufficiently motivated to help themselves through the difficult process of rehabilitation. This view changed when, at a mutual acquaintance's dinner party, she lifted up her arm and asked John what it was: 'John said *da woahs*. Elizabeth said, No, John, listen to yourself. Now listen to me: *ahm*. John said *ahhmm*. No, John, you're saying *ahhmm*. It's not quite right, is it? What is this? This is my ...? John said *ahm*.' (p. 191).

When Sheila asked the therapist how it could be that her husband could read German, English and French but not be able to write a sentence in any language, Elizabeth offered a series of illuminating metaphors: 'It is as though the road between Naples and Rome had been blown up. You can still travel between the two cities, but you have to make your way through the rubble to find an alternative route', or 'The British Library has been shaken by an earthquake. The books have been hurled off the shelves. They're all mixed up and the catalogues can't be found. The books are like

your words: there they are, but you have no means of finding them' (p. 195).

John's semantic understanding of words was excellent, and he could recognize written and spoken reversed letter words, real words and non-words; he could match synonyms, and words to pictures. However, phonological segmentation was a problem: when presented with the words 'map' and 'gap', he was unable to indicate which sound had changed. He knew that both were different. He could identify the number of letters in a word and could fill in blanks in a story but sometimes made dysgraphic errors, writing 'borg' for 'dog'.

A curious deficit was his inability to recognize the subject of a sentence or picture. When presented with a picture of a boy on a bike and asked who was riding the bike, he would point to the word representing the verb ('riding' rather than the word 'boy'). He seemed to have lost understanding of 'who' words that stood for arguments. This lasted for two years. In 1995, his interest in reading for pleasure was rekindled, to such an extent that the house began to be overrun with biographies.

Three years after his stroke, John was able to speak the words haaloo, bye, I, fine, wine, bus, bow, bell, more, my, house and horse. Sometimes, when trying to say one of these words, he would say 'arm' instead. Two years later, Sheila described a typical morning: 'Over lunch he tells me about his morning. *Mmmmmm* means walking along minding his own business. *Arrrr-up!* With his left hand describing an arc means that he has crossed a bridge. He meets a friend: broad smile, greeting gestures; they go into a pub; mime of conversation: *bahbahbahbahbah* – and drinking. Or John gets on a bus: sounds of changing gears, starting and stopping'.

Eventually, his non-language became less prosodic – he would introduce the words *um, oh, ah, aargh, gah, no* and *oh my God* to stem the mellifluous aphasic flow. He took great pains to find the right word, a struggle observed in Zasetsky by Luria (1972) in his book, *The Man with a Shattered World*, as you saw in Chapter 1. 'It was so hard to write', Zasetsky wrote. 'At last, I'd turned up a good idea. So I began to hunt for words to describe it and finally I thought up two. But by the time I got to the third word, I was stuck ... Finally, I managed to write a sentence expressing an idea I had ... sometimes I'll sit over a page for a week or two ... But I don't want to give it up. I want to finish what I've begun. So I sit at my desk all day, sweating over each word'.

However, John's writing made an unusually excellent recovery, but his speech never recovered. At one point in her book, when John was still in hospital, Sheila describes the effect of John's impairment on her. The effect of aphasic patients on those close to them is rarely studied. One October evening, she writes: 'I was too weak to resist a quick, forbidden glance into the future. And what I saw was a succession of meals, sitting across a table from a husband who was no more, or less, companionable than an affectionate dog' (p. 61). John hid his despair well until, one afternoon, his wife found him with his head bowed and his left hand covering his face: 'When I put my arms around him, I felt the tears on his face. He was crying for the first time since I had known him'.

Hale's book is testament to the support, love and care that can help an individual with aphasia to deal with extreme communication difficulty. Despite the impairment in his speech, John continued to be charming, garrulous and intelligent company. David Chambers summed up the positive aspects of Hale when writing the historian's obituary in *The Times*: 'for those in his company, the infinitely modulated exclamations, chuckles and ironical groans which accompanied his enchanting smile seemed almost to amount to conversation. Gregarious as ever, he proved that, even in aphasia, life can be exhilarating.'

Figure 8.4

Some examples of John Hale's writing following his stroke and, inset, John and his wife Sheila (from Hale 2003)

RICARDO WENT OUT SHOPPING TO BUY SOME FRUIT, HE BOUGHT A POUND OF pears, AND A LARGE JUICY WATER melon. HE ALSO WENT INTO THE OFF-LICENCE AND BOUGHT THREE BOTTLES OF wine. HE WALKED HOME ALONG BY THE river AND WATCHED THE MEN ROWING THE boat. A VERY BEAUTIFUL girl WAS SITTING ON A bench SO HE SAT NEXT TO HER. SHE HAD LONG BLONDE hair AND BIG BLUE eyes. RICARDO SAID 'GOOD morning' IT'S A LOVELY day. SHE TURNED TO HIM AND smiled SHOWING LOVELY WHITE teeth. RICARDO OFFERED HER ONE OF HIS pears. THEY TALKED HAPPILY FOR HALF AN HOUR AND THEN RICARDO ASKED HER OUT TO dinner. SHE AGREED AND THEY MET OUTSIDE THE restaurant AT 7.30PM.

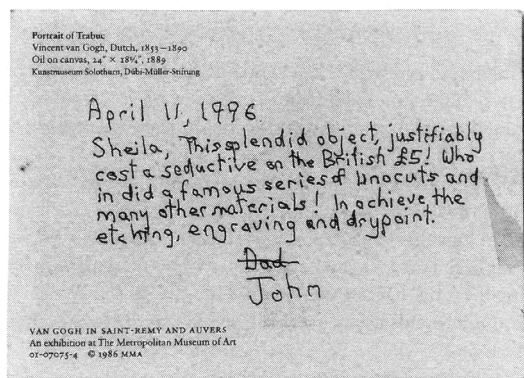
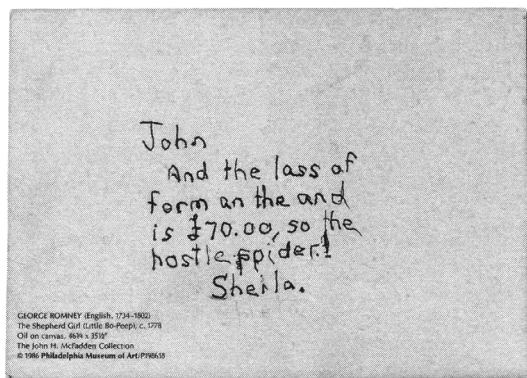

27 Oct. 1996.
Darling Polly,
I am glad John is all right.
I am sure she was better
for these three weeks. Sheila
and I are well. We went to
St. Petersburg with friends
for a week.
Love,
John

20 September 1998
Dear Miranda,
Thank you for the delicious dance on
Friday. I was flattered to be on your
party list and to participate ...
Love
John

aeiou
participate

Does aphasia occur in sign language? the case of Charles

How similar is sign language to 'normal', conventional language? Does it share the same language regions? And, if so, can damage to these regions produce similar deficits in signing to those seen in aphasia? Normal language and signing share many neural features. Sign language is a complete natural language. British Sign Language (BSL), for example, has its own lexicon and grammar and has complex rules of phonology, morphology and syntax (Sutton-Spence and Woll 1999).

Until recently, however, it was thought that language via sign was more dependent on the right hemisphere than the left because the language was considered to be gesture-based (and therefore did not involve the complex analytic processes for which the left hemisphere might be recruited). Sign aphasia has since been reported following left hemisphere damage, but not right (Hickok *et al.* 2002), with similar patterns of impairment to those seen in typical aphasia. For example, damage to Wernicke's area has been found to result in fluent, jargon signing, whereas damage to Broca's area has been found to produce non-fluent, agrammatic signing (Poizner and Kegl 1992).

This does not mean that signing is any different from gesturing (which also carries meaning). However, other features of signing suggest that it is more than a collection of hand movements. Signs can be combined to form grammatical sentences and have phonological structure (Sutton-Spence and Woll 2002). Unlike normal gestures, signs convey meaning via hand shape, movement and location. Change one of these features and you change the meaning of a word completely. The BSL words for 'name' and 'afternoon', for example, share the same hand shape and movement but differ in location.

Cases of sign aphasia are rare but Marshall *et al.* (2004) recently published an extensive account of a 56-year-old deaf man called Charles. Charles had been born to hearing patients. At 54, he had suffered a stroke that left his left posterior frontal and parietal (and probably, temporal) regions damaged. He used BSL, but after the stroke he became highly anomie. He would make many semantic errors, such as signing 'train' and 'bridge' for 'tunnel'. He would also make spelling errors, such as incorrectly finger-spelling words (he signed 'b-o-s' for 'BUS'). However, his visuospatial skills were relatively intact, as was his ability to gesture (this was comparable with three unimpaired deaf individuals).

One explanation for Charles's deficit may be that signs are simply more motorically complex than gestures and therefore more difficult to produce. However, Charles could gesture meaning using movement that was just as complex as that seen in signing. His gesturing was also highly elaborate – when gesturing the use of a toothbrush, he mimed grasping the toothpaste tube, squeezing the tube, holding a brush, turning on a tap, brushing his teeth, and so on.

Charles's deficit suggests that the neural mechanisms underlying signing and gesturing may be different.

Challenges to the traditional model of aphasia

The Broca–Wernicke–Lichtheim model was the common currency of neurolinguistic transactions until the 1970s and 1980s, when case studies began to show that patients with production aphasia were unable to comprehend some types of speech but were capable of understanding other types. The anomaly arose at the level of syntactic complexity. For example, patients with Broca's aphasia (with motor association area lesions) were found to have good comprehension when assessed, but this comprehension was found to be significantly less proficient when they had to understand the syntactic information in a sentence (Caramazza and Zurif 1976; Berndt and Caramazza 1980). When asked to match the sentence, 'The dog was chased by the cat', to the appropriate picture of this action, patients with Broca's aphasia were unable to do so. The more complex the syntax, the more impaired was the comprehension. Nonsensical sentences were also poorly comprehended (e.g. 'The boy the apple is eating is tall'). However, patients were able to complete the matching task when the verb indicated more clearly which animal was doing the chasing in the cat-dog sentence above. Consequently, Berndt and Caramazza (1980) argued that the deficit in Broca's aphasia should be more accurately described as one of disrupted syntax understanding. The motor aspects of the disorder arose from an area – a motor area – adjacent to Broca's area and was therefore unrelated to the language comprehension difficulty. It is possible that the difficulties arising in these patients were not truly syntactic – the patients may have been biased towards choosing pictures that were semantically plausible, for example (Caplan 2002). However, it is notable that when such comprehension difficulties arise, they occur when damage is outside the 'traditionally' demarcated Broca's area (Vanier and Caplan 1990). Caramazza and Berndt (1978) reported that damage in the posterior left hemisphere produced an impairment in the semantic representation of speech that affected production and comprehension. They argued that the difference between Wernicke's and Broca's aphasia was therefore one that reflected the difference between syntax and semantic processing rather than the difference between the sensory representation of words and motor acts.

According to Martin (2003), the data collated since the early 1980s provides mixed evidence for the traditional model and the revised model. Some evidence suggested that damage to Broca's area could lead to motor speech impairment (but no agrammatism) over a period of days (Mohr *et al.* 1978). To produce agrammatism, lesions to the insula and frontal and parietal operculum were required. Dronkers (1996) similarly argued that damage to the insula led to a disruption in the motor apparatus necessary for planning speech. As an earlier section pointed out, the 'unity' of Wernicke's area has also been questioned (Wise *et al.* 2001) – it does not seem as clearly demarcated as Broca's area, for example. It is normally defined as the posterior one-third of the superior temporal gyrus, but in order to produce long-lasting Wernicke's aphasia, a more extensive lesion is required (Selnes *et al.* 1983; see also Martin 2003). Other observations suggest that damage to areas outside Wernicke's area can produce symptoms of Wernicke's aphasia (Murdoch *et al.* 1986).

These neuropsychological observations are often reflected in therapists' experiences of rehabilitating individuals with language difficulties – the clear symptom specificity predicted by the Broca–Wernicke–Lichtheim model is rarely observed. Symptoms are a mix of deficits. This highlights one of the messy truisms of neuropsychology: the consequences of brain injury are never as simple as models would like. Blumstein (1998), for example, found that an impairment in the ability to identify and discriminate between phonemes and words when spoken is common to all aphasias. These caveats are usefully borne in mind when reading empirical, academic accounts of aphasia.

Specific language functions

On the basis of data from neuroimaging and brain lesion, a complex pattern of brain region involvement reflects our ability to recognize spoken words, produce speech, represent the semantic nature of words, represent the grammatical function of words, and recognize and speak sentences. Some of this evidence is reviewed next; evidence for neural involvement in that other important language function – reading – is reviewed later in the chapter.

Spoken word recognition

The ability to recognize speech as speech appears to be different to the ability to perceive non-speech stimuli. Patients who show symptoms of pure word deafness, for example, can recognize music or environmental sounds better than they can speech. One explanation for this deficit may be that speech involves the perception (and analysis) of a complex and rapid series of sounds with a variety of pitches. Evidence for such an explanation rests in studies where non-speech sounds are poorly recognized if the recognition depends on the perception of rapid change in the delivery of these stimuli (Wang *et al.* 2000). Unlike the aphasic disorders reviewed above, pure word deafness can be produced by bilateral lesions to the temporal lobes or by unilateral left hemisphere lesions, suggesting that both hemispheres can be involved in extracting the phonetic cues from speech (Praamstra *et al.* 1991). Other studies have reported patients with left-based parietal and temporal lesions who show good phoneme discrimination but poor spoken word recognition in tasks where elements have a lexical component, e.g. deciding whether words are synonyms (Martin and Saffran 1992). Left parietal lesions have been associated with good performance on auditory and written lexical decision tasks but not on auditory semantic tasks (Hall and Riddoch 1997). Semantic processing was not impaired when the task was written rather than spoken, suggesting that the representations of lexical and phonological information and the link between this and meaning is disrupted. All the studies reviewed here suggest left hemisphere involvement in this but bilateral involvement in auditory feature extraction.

Spoken word production

Most patients with brain lesions affecting speech production produce a variety of speech errors rather than a specific type (Martin 2003). Typical errors include mistaking one object for another (a semantic error – saying ‘banana’ to a picture of a ‘courgette’, for example), confusing a word’s phonology (saying ‘golf’ instead of ‘glove’) or neologizing based on phonology (e.g. saying ‘brind’ when the patient meant ‘bread’). Patients with anomic aphasia, for example, are unable to find words in spontaneous speech but can repeat sentences fluently. Damage in these patients is often outside the perisylvian regions in the temporal cortex (Damasio and Damasio 1989). When semantic knowledge is intact but word finding is severely impaired, the left posterior temporal lobe may be lesioned (Hillis *et al.* 2001).

These data from single-case studies are complemented by those from neuroimaging. A review of the activations found during speech production concluded that the left posterior, middle and superior temporal cortices were activated when people retrieved word forms

based on sound (Indefrey and Levelt 2000). The regions involved in ‘sublexical phonological coding’, which, when impaired, produces the brind/bread confusion, are less consistently clear but appear to include the left posterior and inferior frontal gyrus and superior temporal gyrus.

Although people with brain damage resulting in aphasia may show impaired speech production, some aspects of word generation, such as counting, remain unaffected. This type of language production has been described as ‘automatic’, possibly because our learning through repetition during development leaves the process relatively unimpaired. As you saw in Chapter 4, this type of ‘automatic’ speech production task is used to investigate patients’ dominant language hemisphere prior to surgery (so that the surgeon can avoid, or minimize, lesioning the language areas). Neuroimaging research suggests that the language area subserving this ‘automatic’ speech is different to that which subserves other language abilities, such as novel word production (e.g. naming as many animals as possible).

Vanlancker-Sidtis *et al.* (2003) compared normal and aphasic individuals’ brain activity and cognitive performance during a counting task and an animal name generation task. To examine whether brain activation during meaningful word production would be similar or dissimilar to that seen during ‘meaningless’ non-language vocalization, participants were also asked to make gargling, snoring or ‘brrrr’ type noises (the latter made by putting the lips together and blowing air out of the mouth).

Normal language users were significantly better at the word production task but were similar to the aphasic participants in their performance of other tasks. In normal participants, the three tasks elicited activation in different brain regions: the naming and vocalizing tasks were both associated with frontal bilateral (but largely left) activation; the naming task alone activated left and right frontal and temporal cortices; the counting task alone activated right hemisphere and subcortical regions, but these changes were not consistent.

The aphasic individuals showed a reduction in activation of right hemisphere regions contributing to articulation and regions outside the stroke areas during the naming and vocalizing tasks. When aphasic and normal groups were compared, greater activation was seen in the left temporal and parietal cortex in normal participants. When naming alone was examined, the aphasic patients activated areas in the left hemisphere associated with naming but also activated other novel areas not activated in the normal group (perhaps reflecting task difficulty or effort). When counting was compared with the other tasks, aphasic patients appeared not to use different brain regions for counting.

That both groups performed equally well on the counting task and that the counting task was associated with right hemisphere activity in normal participants suggests that this language exercise may not involve phonological or semantic processing and therefore may not be the best means of mapping the cortical speech areas in pre-operative patients.

Grammatical representation of words

In case studies of neurolinguistics, there is a frequently reported double dissociation between function words and content words and between nouns and verbs, i.e. word class. The evidence from this arises from patients who are able to determine the gender of words or whether a word falls correctly into a phrase but are unable to retrieve the phonological information carried by the words (Badecker *et al.* 1995; Vigliocco *et al.* 1999). A distinction is sometimes made between the mental lexicon and the mental grammar. The lexicon contains words where the meaning and sound have been paired and memorized. The sound and meaning of the word ‘cat’, for example, cannot be determined by reference to each

other. It also contains ‘bound morphemes’ (words that end in ‘-ed’) and phrases. The mental grammar contains the rules that govern the use of such words and how lexical forms give rise to words and phrases. From this distinction, it seems clear that regular words such as ‘climbed’ are governed by the mental grammar, whereas irregular words such as ‘ran’ (past tense of ‘run’) are contained in the lexicon. Neuropsychologically, there is evidence that some patients are impaired at regular word reading and others impaired at irregular word reading. Non-fluent aphasia, for example, is associated with poorer production of the reading aloud, writing and repetition of regular English past tenses (Ullman *et al.* 1997a). However, when the complexity of the phonology in these words is controlled for, this disparity disappears (Bird *et al.* 2003). This finding applies most consistently for the English language; whether poor performance can also be observed in other languages is unclear. Conversely, fluent aphasia is associated with poorer irregular verb processing in English and in Japanese (Ullman *et al.* 1997b; Marslen-Wilson and Tyler 1998; Hagiwara *et al.* 1999). To determine whether such a dissociation was genuine and replicable, Ullman *et al.* (2005) examined twenty patients with aphasia. Those who were non-fluent with agrammatic speech were less able to produce and read regular than irregular past tenses. Patients with the fluent variant who showed word-finding difficulty were poorer at producing irregular verbs than regular ones. Even when the complexity of the words and their sound, frequency and articulatory difficulty were controlled for, the dissociation remained. Damage in the former group was in the left frontal region; in the latter, the temporo-parietal area. The lesions suggest that the left frontal region may mediate the lexicon and the temporo-parietal cortex the grammar.

The production of sentences

Much of the evidence discussed so far has focused on the consequences of brain injury on reading single words. However, bringing together several single content and function words into a coherent, syntactically sound form is an important human communication function. Patients with Broca’s aphasia, for example, show speech that is agrammatic – function words and inflexions are missing, and grammar may be very simple. With patients exhibiting ‘paragrammatic speech’, there is fluent word production, but function words may be substituted for other, inappropriate, ones. The simplified grammar manifests itself in the use of default verb forms – an uninflected infinitive in English, for example, but inflected ones in other languages (Menn 2001). Patients with Wernicke’s aphasia sometimes generate too many verb forms, especially ones of high frequency. In both types of aphasia, however, a characteristic of the grammar used is reduced structural complexity (Bird and Franklin 1995/6). That said, some patients’ grammar is syntactically very complex, but inflexions are often inaccurate (Thompson *et al.* 2002).

In studies of healthy individuals, areas overlapping BA 44 are implicated in sentence production. In one experiment, participants were asked to describe an animated presentation of moving, coloured stimuli using either full sentences, a sequence of phrases (e.g. red square) or sequences of words with no syntactic structure (e.g. red, square). Regions overlapping Broca’s area but primarily posterior to it were most strongly activated by sentences (Indefrey *et al.* 2001). The next greatest activation was found during phrase production, then non-syntactic phrases.

The areas recruited during the reading of sentences are considered in the next part of the chapter.

Neuropsychology of normal reading

Current neuroimaging work has helped to define those areas necessary to and/or sufficient for the skills and processes involved in reading in normal, proficient readers. Studies generally highlight the importance of at least the left hemisphere perisylvian regions in reading (e.g. Fiez and Petersen 1998; Brunswick *et al.* 1999), especially the anterior language area in the region of the left frontal operculum (Paulesu *et al.* 2000), the posterior temporo-parietal language area encompassing the posterior superior temporal gyrus (Paulesu *et al.* 2000; McDermott *et al.* 2003), the supramarginal gyrus and the angular gyrus (Vandenberghe *et al.* 1996a, b; Rumsey *et al.* 1997); and the posterior occipito-temporal language area, including the posterior basal temporal cortex and the fusiform gyrus (Brunswick *et al.* 1999; McCandliss *et al.* 2003). The regions activated during reading in normal readers can be seen in Figure 8.5. These and other language regions have shown activation during orthographic processing (processing the written form of letters and words), phonological processing (processing the spoken form of letter clusters and words) and semantic processing (processing the meaning of words and sentences).

Figure 8.5

Some of the brain areas implicated in the process of reading

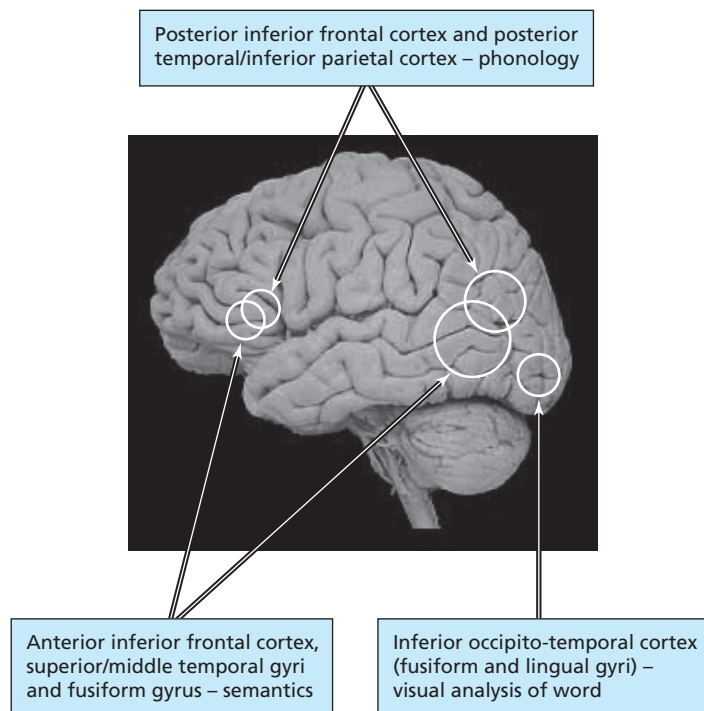

Translating from print to sound

Studies designed to map the brain regions involved in the translation of orthography (the printed word) to phonology (the spoken word) during reading have compared patterns of activation recorded during the reading/viewing of words and the naming/viewing of pictures (Bookheimer *et al.* 1995; Vandenberghe *et al.* 1996), and during the reading of pseudowords, and regular and irregular words (Price *et al.* 1996).

Comparing the reading of pseudowords with the reading of regular words has revealed regions of greater activation in the left inferior frontal cortex and the occipito-temporal cortex (Price *et al.* 1996; Ischebeck *et al.* 2004); the same pattern of activation has been found when comparing reading with viewing consonant letter strings (Price and Friston 1997). The reading of pseudowords and irregularly spelled real words has been associated with increased activation in the left inferior frontal gyrus, while the reading of regular words and letter strings has been associated with increased activation in the occipito-temporal cortices and the posterior left middle temporal gyrus (Herbster *et al.* 1997; Fiebach *et al.* 2002).

The consistency of these patterns of activation in tasks involving ‘assembled’ phonology and ‘addressed’ phonology has suggested a link between these specific brain regions and the pathways to reading: activation of the left inferior frontal cortex during rule-based orthographic–phonological translation suggests that this region may play a role in ‘assembled’ phonology and that it may form part of the grapho-phonological route to reading. Activation of the left posterior middle temporal gyrus during tasks involving whole word phonology suggests that this region may play a role in ‘addressed’ phonology and that it may form part of the lexico-semantic route to reading (Simos *et al.* 2002) along with the occipito-temporal cortex, which is associated with the recognition of visual word forms (Fiebach *et al.* 2002).

Deriving meaning

Although the left prefrontal/inferior frontal cortex was originally linked with semantic processing through the work of Petersen *et al.* (1990), its specific involvement in semantic tasks was questioned by the finding that the region is also active during tasks requiring phonological processing (Pugh *et al.* 1996). Others have simply failed to observe activation in BA 47 during semantic processing (e.g. Price *et al.* 1996; Herbster *et al.* 1997). It is possible that phonological processes are automatically activated during semantic processing, so any attempt at dissociating those regions that are solely involved with semantic processing from those that are solely involved with phonological processing will necessarily be problematic (see Poldrack *et al.* 1999).

One study, designed specifically to tease apart the relative involvement of the prefrontal regions in semantic and phonological processing, required participants to perform a series of tasks involving semantic and phonological processes (Gabrieli *et al.* 1998). This study revealed a functional dissociation between regions within the left prefrontal cortex such that the more anterior regions were associated with semantic classification, while the more posterior frontal regions were associated with phonological processes (e.g. rhyming and sub-vocal articulation). Support for this finding is provided by McDermott and colleagues, who observed activation in the left anterior/ventral inferior frontal gyrus, the left posterior/dorsal inferior frontal gyrus, the left superior/middle temporal cortex, the left fusiform gyrus and the right cerebellum during semantic processing. Activation of the left inferior frontal cortex (posterior to the semantic inferior frontal gyrus regions)

and bilateral inferior parietal cortex and precuneus was observed during phonological processing (McDermott *et al.* 2003).

The identification of the left inferior frontal cortex as playing a key role in semantic classification is interesting, as this region has been identified as part of a ‘semantic system’ – including the left inferior temporal and left posterior inferior parietal cortices – that responds to written words. Of these regions, the left inferior temporal and posterior parietal regions are reported to be more active in response to sentences than to individual, unrelated words (Bottini *et al.* 1994) and more active in response to stories than to individual, unrelated sentences (Fletcher *et al.* 1995). It is suggested that the left inferior frontal cortex undertakes an executive role, controlling the retrieval of semantic information from the more posterior regions (Fiez 1997).

In their review of nine neuroimaging studies of single-word reading, Fiez and Petersen (1998) observed that activation of the left hemisphere inferior occipito-temporal border in the fusiform and lingual gyri was consistently associated with visual analysis specific to reading. Activation of the inferior frontal cortex was associated with articulatory-based phonological analysis. Activation of the left posterior temporal cortex was associated with acoustically based phonological analysis, while activation of the anterior superior temporal cortex was associated with hearing one’s own voice reading aloud. Activations near the border of the superior and middle temporal gyri were associated with semantic analysis, while activations in the post-central gyrus, in the region of the supplementary motor area and in the cerebellum, were associated with speech production.

Pathways to reading

Drawing together such data, Pugh and colleagues have identified three cortical circuits (one anterior circuit and two posterior circuits, with dorsal and ventral streams) that appear to underlie skilled alphabetic reading (Pugh *et al.* 2000). The anterior circuit, active during silent reading and naming and engaged more in response to low-frequency words and pseudowords than to high-frequency words, is localized in the region around the inferior frontal gyrus (including Broca’s area). This anterior system appears to function in concert with the posterior dorsal circuit to support normal reading development.

The posterior dorsal circuit includes the angular gyrus and the supramarginal gyrus in the inferior parietal cortex, and the posterior part of the superior temporal gyrus (including Wernicke’s area). On the basis of neuroimaging evidence, it is thought that this dorsal stream predominates over the ventral stream in early readers faced with the effortful task of reading printed text, while the dorsal stream predominates in skilled readers during the reading of pseudowords and low-frequency words compared with familiar words (Pugh *et al.* 2001). Measures of blood flow in the left hemisphere superior temporal cortex have been positively related to behavioural accuracy on an orthographic task and to documented childhood reading ability; blood flow in the angular gyrus was negatively related to childhood reading ability (Flowers *et al.* 1991). On the basis of such evidence, it is suggested that the regions of which the dorsal stream is comprised are associated with slow, rule-based reading involving grapheme–phoneme recoding and with mapping these orthographic and phonological representations onto their corresponding morphological and semantic associates (Pugh *et al.* 2001; Shaywitz *et al.* 2002).

The ventral stream of the posterior circuit comprises the lateral extrastriate cortex and the left occipito-temporal junction (including the middle and inferior temporal gyri). In skilled readers, this stream is activated more strongly by familiar words than by pseudowords and more by pronounceable pseudowords than by unpronounceable non-words

(Brunswick *et al.* 1999; Tagamets *et al.* 2000). Early readers show increased activation within the ventral system after an initial period of reading instruction; this increase is commensurate with their increased reading proficiency (Shaywitz *et al.* 2002). Taken together, these data indicate the importance of the ventral stream for skilled, automatic word recognition (Pugh *et al.* 2001; Shaywitz *et al.* 2002).

Discussion point: does reading in Braille activate the same brain regions as normal reading?

The origin of language probably lies in the motor system of our brain. Gesturing preceded the sophisticated vocal communication of evolutionary modern times but gesturing is still used to communicate. Congenitally deaf people, for example, use British or American Sign Language. But to what extent does the brain have different systems for understanding the different types of communication – those that rely on our ability to hear and those that rely on our ability to decipher symbols or actions?

These questions assume an absolute definition of language. Goldberg has suggested that instead of referring to language *per se*, we should adopt the more general term ‘descriptive systems’ (Goldberg 1989). Under this umbrella, he includes various cognitive systems (‘superstructures’) that are normally employed to assemble the ‘codes’ received via the elementary ‘feature detection’ systems such as the visual and auditory cortices. Language, as traditionally defined, is one such system. Others include mathematical or computational languages and musical notation. Early encounters with these systems are characteristically tentative, but gradually familiarity develops into automatic processing.

Schlesinger (1988) has observed a specific inability in some deaf children to manipulate the linguistic code, i.e. they experience difficulty in understanding questions, they are unable to formulate hypotheses, they have difficulty in conceptualizing superordinate categories, and they appear to exist in a ‘preconceptual, perceptual world’. In short, these people display precisely the syntactic and semantic deficits associated with isolated right hemisphere speech in those who have experienced left hemisphere damage in later life. Perhaps these deficits are caused by a shift from an initial stage of right hemisphere language to mature left hemisphere language. Neville (1989), for example, has found that only deaf people with a perfect grasp of English grammar displayed ‘normal’ left hemisphere specialization, concluding that both in the deaf and in those with normal hearing, grammatical competence is necessary and sufficient for left hemisphere specialization if it occurs early. Early competence in spoken or signed language brings about this development of the left hemisphere and bestows an advantage on the right side of perceptual space, i.e. the right visual field and the right ear, via the dominant contralateral sensory pathways. Obviously, this perceptual advantage is grossly impaired following left hemisphere damage.

Unfortunately, this early exposure to signed language that brings about the shift of language functions to the left hemisphere is not always available to deaf children. Evidence has shown that hearing children of deaf parents and deaf children of deaf parents acquire sign language in infancy as a primary language and tend to show the shift to left hemisphere mediation of language (Grossi *et al.* 1996). However, many deaf children of hearing parents have only restricted exposure to sign language during the critical period of development, a privation that may lead to a total arrest or delay (depending on

the degree of deficiency of the linguistic experience) of cerebral maturation. In this situation, the child would continue to display signs of predominantly right hemisphere language as predicted in the absence of a shift to left hemisphere dominance.

Individuals who are deaf but have learned sign language appear to show activation in areas of the right hemisphere while signing. Using fMRI, Neville *et al.* (1998) measured brain activation in three groups of people: monolingual speakers of English who could hear; native deaf signers of American Sign Language (ASL); and bilingual users (of English and ASL) who could hear. Participants watched a videotape recording of a deaf signer producing sentences in ASL and read English sentences presented on a computer monitor. The study found that although all groups activated the typical left hemisphere areas (Broca's and Wernicke's) when they processed English sentences, the native users of ASL also showed corresponding increases in activation in the right hemisphere.

Could the results have been attributable to the possibility that deafness had led to a reorganization of the cortex in the deaf participants? This is unlikely, because both the hearing and deaf participants who were fluent ASL signers showed the same right hemisphere activation. Paulesu and Mehler (1998) have suggested that this pattern of activity may instead reflect the possibility that the right hemisphere holds the grammar for sign language, because it requires representations of both sides of the body. Because neuroimaging studies of sign language are relatively rare, this hypothesis has yet to be tested. However, it seems reasonable given the role of the right hemisphere in processing spatial relationships (such as interpreting movement in space).

In the first brain-imaging study of the perception of British Sign Language, nine hearing and nine congenitally deaf individuals had their brain activity measured by fMRI during the perception of sentences presented in BSL (MacSweeney *et al.* 2003). An analogous auditory task in English was completed by hearing individuals. Regardless of the modality of communication, there was activation in Broca's area and in Wernicke's area – both bilaterally – during the language perception tasks. However, differences did emerge between tasks in the temporal and occipital areas. The auditory task in hearing individuals was associated with increased activity in the auditory cortices. This activation was not found during BSL. BSL, on the other hand, was associated with activity in an area called V5 at the junction of the temporal and occipital cortex. V5 is the region of the visual cortex that responds to movement, so activation here is consistent with what we know of the neurology of visual perception.

When hearing and deaf people's responses to BSL were explored, however, deaf signers showed greater activation in the left superior temporal cortex than did hearing signers. This result is intriguing because it suggests that the auditory cortex of the temporal lobe is active during an auditory language task in hearing individuals but that it may respond to visual input in congenitally deaf individuals.

This part of the temporal lobe has been described as a multi-modal language area (Büchel *et al.* 1998) because it can be activated by language processed in different modalities. The MacSweeney study indicated that this was so for sign language. Büchel *et al.* observed a similar phenomenon when studying blind participants reading Braille. When people engaged in tactile reading, the posterior left temporal area (BA 37) was active. Büchel *et al.* proposed that this area in blind, Braille-reading participants promotes activity in other parts of the brain that allows participants access to words. However, this area was active only during written word recognition, not spoken word recognition.

Discourse

Approaches to studying complex linguistic stimuli tend to fall into two camps: one explores the processing involved in understanding connected discourse and narratives; the second explores individuals' understanding of specific aspects of these discourses such as a moral theme they might contain (Gernsbacher and Kaschak 2003). Activation in the superior temporal gyri and left middle temporal gyrus is associated with passive listening to stories (Tzourio *et al.* 1998), although right frontal regions have also been implicated during the reading of sentences (Robertson *et al.* 2000). The right hemisphere appears to play an important role in discourse processing. When participants read stories that are titled or not titled, activation in the right hemisphere is stronger when stories are titled, suggesting that this hemisphere is attempting to make coherent sense of the narrative (St George *et al.* 1999). It also suggests that right hemisphere involvement occurs only when participants are trying to make such sense of connected words and not when simply passively listening to them. As Chapter 4 noted, the right hemisphere is activated when participants attempt to make sense of metaphors, irony and abstract words (Bottini *et al.* 1994).

The right hemisphere is also activated by the perception of themes in discourse. In one PET study, participants read Aesop's fables and answered questions about the nature of the characters or about the moral content (Nichelli *et al.* 1995). Activation that was moral-specific was observed in the right inferior frontal gyrus and middle temporal gyrus, although activation does depend on the nature of the understanding and recall of the stories. If the reading task involves encoding autobiographical memories associated with the stories, there is activation in the left prefrontal cortex; theory of mind stories – in which the participant has to adopt the perspective of another – are associated with activation in the frontal gyrus on the left and the posterior cingulate (Fletcher *et al.* 1995). Some of the regions implicated in story narration and comprehension are illustrated in Figure 8.6.

Figure 8.6

Some of the brain areas showing activation during the production and comprehension of stories (from Mar 2004)

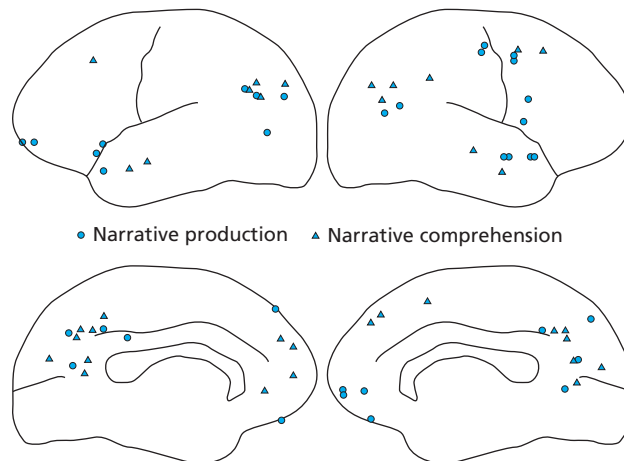

The neuropsychology of reading: dyslexia

As with aphasia, the generic label ‘dyslexia’ (indicating ‘impaired reading’) encompasses many subdivisions, although these fall under two main headings: acquired dyslexias and developmental dyslexia. The primary characteristics of each are summarized in Table 8.2.

Acquired dyslexia

Acquired dyslexia, as the name implies, describes a reading impairment that follows brain damage in individuals with previously normal levels of reading ability. In a classic paper, Marshall and Newcombe (1973) described three types of acquired dyslexia characterized by paralexias (speech errors). These types were visual dyslexia (patients make visual errors such as reading ‘dug’ for ‘bug’), deep dyslexia (where errors are semantic, ‘little’ may be read as ‘small’) and surface dyslexia (where patients attempt to sound out a word, so that ‘yacht’ would be read and pronounced ‘yakt’). Each of the principal classes, and an additional type – phonological dyslexia – is described below.

Visual word form dyslexia

Individuals with visual word form dyslexia are unable to recognize words immediately but are able to read words when given time to name the individual letters of the word (Warrington and Shallice 1980). The severest forms result in poor recognition of individual letters: a patient with visual word form dyslexia may respond with ‘c, a, t . . . cat’ when presented with the word ‘mat’. The individual reads on the basis of the letters that they perceive rather than the letters that are actually printed.

Table 8.2 The dyslexias

Type of dyslexia	Primary symptoms	Brain regions implicated
The acquired dyslexias		
Visual word form dyslexia	Impaired sight reading; some decoding is possible.	Disconnection between the angular gyrus of the dominant hemisphere and the visual input system.
Phonological dyslexia	Deficits in reading pseudowords and non-words.	Temporal lobe of the dominant hemisphere?
Surface dyslexia	Tendency to produce regularization errors in the reading of irregular words.	?
Deep dyslexia	Semantic substitutions, impaired reading of abstract words, inability to read non-words.	Extensive damage to the dominant hemisphere.
Developmental dyslexia	Impaired reading and spelling of words/non-words/pseudowords, poor phonological processing skills, sequencing and short-term memory, some visuo-perceptual defects.	Temporo-parietal regions of the dominant hemisphere.

Speedie *et al.* (1982) have suggested that visual word form dyslexia is the result of a disconnection between the angular gyrus of the left hemisphere, which normally mediates the recognition of word forms, and the visual input system. In order to compensate for this disconnection, patients rely on the visual and perceptual functions of the intact right hemisphere. Once the right hemisphere has identified the letters, this information is sent via the corpus callosum to the speech areas of the left hemisphere, the letter sounds are accessed, the patient ‘hears’ the word spelled out and is able to recognize it.

Phonological dyslexia

Phonological dyslexia describes an impaired ability to read pseudowords and non-words. These words cannot be read via the direct lexical access route from print to sound (i.e. ‘reading by eye’). This route represents the process whereby readers recognize known words visually, as familiar letter strings. Repeated encounters with a word result in the formation of a ‘visual word recognition unit’, which serves to access the word’s meaning (semantic representation) in the mental lexicon. Obviously, lexical entries do not exist for words that have never been seen before. Reading therefore relies on grapheme–phoneme translation. The grapheme–phoneme route from print to sound (‘reading by ear’) may be conceptualized as the ‘sounding out’ of words on the basis of their spelling–sound correspondences. On the basis of the resulting acoustic representations, the individual’s auditory word recognition system may recognize the word as if it had been heard rather than read. Following this route, it may be possible to read words or non-words regardless of whether they have been encountered before.

Although phonological processing impairments are a characteristic feature of developmental dyslexia (see below), acquired phonological dyslexia is relatively rare. Little is known about the cortical involvement in the disorder, although studies of the phonological impairments in developmental dyslexia suggest the abnormal development of the temporal region of the left hemisphere (Rosenberger 1990; Wood *et al.* 1991; Galaburda *et al.* 1994).

Surface dyslexia

Surface dyslexia is the inability to recognize words on the basis of their physical appearance, i.e. by the direct lexical access route (see Ellis *et al.* 2000). However, the ability to decode words by applying grapheme–phoneme correspondence rules is spared. Individuals are able to read regular words and non-words, but they have specific difficulties with irregular words (e.g. ‘yacht’ is likely to be read as ‘yatcht’). The exact location of damage responsible for this disorder is unknown.

Deep dyslexia

Deep dyslexia describes a severe impairment in the ability to read. Concrete nouns can be read, although they are frequently replaced by semantically related words. For example, attempting to read the word ‘dream’, a person may say ‘sleep’ (Coltheart *et al.* 1980). Abstract words are very rarely read successfully, and the apparent inability to apply grapheme–phoneme correspondence rules renders individuals with deep dyslexia unable to read pronounceable non-words (Patterson and Marcel 1977). Coltheart (1980) has listed twelve properties of deep dyslexia:

1. semantic errors;
2. visual errors (more common for abstract than for concrete words);
3. function word substitutions;

4. derivational errors (e.g. reading 'beggar' for 'beg');
5. impaired ability to derive phonology from print non-lexically;
6. impaired ability to derive phonology from print lexically;
7. words with low imageability are more difficult to read than high-imageability words;
8. verbs are more difficult to read aloud than are adjectives, and adjectives are harder to read than are nouns;
9. function words are harder to read aloud than content words;
10. spontaneous writing is impaired;
11. verbal STM is impaired;
12. reading aloud is context-dependent.

Deep dyslexia is usually associated with extensive damage to the left hemisphere. Because the damage generally results in global language impairments, localizing the precise cortical area producing the deep dyslexia is problematic. The similarities between the symptoms of deep dyslexia and conduction aphasia have led to the suggestion that these specific reading deficits may result from (1) lesions to cerebral areas responsible for phonological decoding, and (2) a disconnection of the mechanisms responsible for the visual perception of words and those responsible for speech production. The nature of deep dyslexia is explored in more detail in the case study below.

Deep dyslexia: the case of GR

One of the first case studies of deep dyslexia, and the one that precipitated much of the subsequent work on the cognitive neuropsychology of reading, was Marshall and Newcombe's (1966) patient, GR. At the age of 20, GR was on soldier duty when he fell off his lorry and accidentally shot himself in the head. The bullet passed the front of his left ear and through his temporal and parietal lobe, causing damage to the Sylvian fissure. He developed a severe language disorder and was unable to produce speech – he would grunt instead of saying 'yes' or 'no'.

Almost thirty years later, Marshall and Newcombe (1973) reported GR's residual language deficits. These were unusual. GR's speech was characterized by a lack of function words and was telegraphic. However, his ability to articulate was good: he could repeat single words, foreign words, phonemes and numbers (but not series of stimuli such as months of the year). He could write about a third of the alphabet when dictated to him. His comprehension was good, but he had difficulty following complex instructions. He could read nouns well but adjectives less so and verbs very poorly.

His greatest problem was in reading function words: prepositions, conjunctions and pronouns. Characteristically, he would substitute one word for another, e.g. he would read 'for' and 'other' as 'and'; or 'her' and 'his' as 'she'. He would often make semantic errors, such as producing a word that was semantically related to the word he was reading: instead of 'antique', he would read 'vase'. He would also make mistakes involving surface visual features, reading 'deep' instead of 'deer' and 'perform' instead of 'perfume'. Table 8.3 summarizes GR's reading problems.

Based on GR's features, Marshall and Newcombe described the principal features of deep dyslexia as an inability to read words representing grammatical class and the commission of semantic errors. They also noted that similar semantic errors could be

Table 8.3 Some of the reading errors made by GR

Type	Stimulus	Response
Semantic	antique	vase
	canary	parrot
	liberty	freedom
	gnome	pixie
Visual	deep	deer
	bad	bed
	shallow	sparrow
	wide	wisdom
Derivational	beg	beggar
	political	politician
	length	long
	heat	hot
Visual/semantic	sad	sack
	brass	band
	low	shallow
	young	strong
Function word substitutions	for	and
	her	she
	other	and
	his	she

Source: adapted from Funnell 2002.

produced in normal readers if the reading task involved a memory component or if completed under time restrictions. Marshall and Newcombe proposed that GR's deficits reflected a two-pathway model of oral reading: the first pathway (semantic) reads whole written words and attributes meaning to them; the second (sublexical) breaks down the words into letters and letter groups and reads these by sound (grapheme–phoneme conversion). According to this model, GR had lost his ability to use the sublexical route, which forced him to use the semantic route. His semantic errors were attributable to problems with his semantic route. Other case studies suggest that deep dyslexia is associated with severely impaired grapheme–phoneme conversion. Saffran and Marin's (1977) patient, VS, for example, was unable to make judgements about the sound of a written word, reading instead by vision rather than sound. When the patient was asked which of the words 'cuff', 'brought', 'cut' and 'cough' rhymed with 'rough', VS selected 'cough'.

One explanation for the deficits seen in deep dyslexia is that the damaged left hemisphere is behaving dysfunctionally. However, a study of five patients with deep dyslexia with left hemisphere damage suggests that the right hemisphere might be involved in some way – the damage to the left was so extensive that reading could not possibly be undertaken by this one hemisphere (Coltheart *et al.* 1980; Coltheart 1980). In a neuroimaging study of deep dyslexia, Price *et al.* (1998) found that whereas normal controls showed activation in the classic perisylvian fissure region of the left hemi-

sphere, patients with deep dyslexia activated areas outside the sylvian areas in the left temporal lobe. The patients also showed increases in activation in the right inferior occipital gyrus and parahippocampal gyrus during visual object perception.

Developmental dyslexia

Developmental dyslexia, as defined by the World Federation of Neurology, is a difficulty in learning to read despite adequate intelligence and appropriate educational opportunities (Critchley 1973). The children, most commonly boys, may be bright and articulate and even excel in other areas of achievement, but they show severe delays in learning to read.

More recently, attempts have been made to identify subgroups in the developmental dyslexic population in line with the acquired dyslexias. These subgroups are generally formed either on the basis of clustering observations of functional impairment (Fletcher and Satz 1985; Bakker 1990) or by drawing analogies between the impairments seen in developmental dyslexic readers and those seen in acquired dyslexia (Seymour 1986; Castles and Coltheart 1993). The resultant classifications have generally involved distinguishing between two types of developmental dyslexia. One is characterized by a primary deficit in the ‘sounding out’ of words (applying grapheme–phoneme translation rules), the other by an impaired ability to identify words on the basis of their visual forms. These two syndromes have variously been labelled dysphonetic and dyseidetic dyslexia (Boder 1973; Fried *et al.* 1981), phonological and surface/morphemic dyslexia (Temple and Marshall 1983; Seymour and MacGregor 1984) and P-(perceptual)type and L-(lingual)type dyslexia (Bakker 1986, 1992).

In spite of these various attempts to fractionate developmental dyslexia, a vast amount of evidence consistently indicates that a particularly salient and enduring characteristic of the disorder is poor phonological awareness (Stahl and Murray 1994). Dyslexic individuals perform poorly on tests measuring rhyme awareness, rhyme production ability, the ability to segment words into their individual sounds, awareness of alliteration, verbal repetition and verbal naming (Brady *et al.* 1989; Brunswick *et al.* 1999; Bryant *et al.* 1990; Katz *et al.* 1981; Lundberg *et al.* 1980; MacLean *et al.* 1987; Rippon and Brunswick 2000; Snowling *et al.* 1986, 1988).

A complementary aspect of phonological processing in dyslexia is impaired verbal memory. The acquisition of proficient literacy skills is dependent, to a considerable extent, on the child’s memory (Gathercole *et al.* 1991). Memory is strongly implicated not only in the ability to link the sounds and visual forms of letters (Hulme 1988), but also in the development of spoken vocabulary and general language skills (Ellis and Large 1988). Phonological memory has been considered as another source of impairment in developmental dyslexia (Snowling and Hulme 1989). Dyslexic readers demonstrate reduced memory span, relative to good readers, for letter strings (Holligan and Johnston 1988), unrelated word strings (Beech and Awaida 1992; Brunswick *et al.* 1999), words in a sentence (Wiig and Semel 1976) and strings of digits (McCrory *et al.* 2000). These memory deficiencies are not restricted to printed stimuli, but they are language-dependent: unfamiliar faces, abstract designs or visual patterns fail to elicit similar memory impairments (Liberman *et al.* 1982).

However, memory deficits may not be enough to explain the ‘severe and intransigent reading difficulties’ that these individuals experience (Hulme and Roodenrys 1995). Phonological memory skill is only one aspect of the individual’s cognitive armoury.

Visual perception, the ability to process and discriminate between visually presented forms, is another cognitive skill important for normal reading development. Dyslexic readers have shown impaired ability to copy complex figures (Satz and Sparrow 1970; Eden *et al.* 1993), to match visual figures (Eden *et al.* 1993), to retain visual images in memory (Johnson and Blalock 1987) and to orient visually (Johnson and Grant 1989). Poor visual direction sense, binocular convergence and visual fixation have also been suggested as factors leading to delays in learning to read (Stein 1991).

Studies have highlighted the importance of more fundamental aspects of visual processing. Vision is mediated by two parallel systems (cell layers) in the dorsal lateral geniculate nucleus: the magnocellular system and the parvocellular system. The parvocellular system is involved in the processing of colour and fine detail, while the more primitive magnocellular system includes cells specialized for the detection of orientation, movement, direction and depth perception (Dautrich 1993). It is this latter system that has been implicated in developmental dyslexia. For example, research has shown that specific oculomotor difficulties, such as poor binocular convergence, impaired ability to track a left-to-right moving target visually and poor eye stability in visual fixation may lead to problems in learning to read (Willows *et al.* 1993; Eden *et al.* 1994). The functioning of the cortical target for the magnocellular pathway, area V5, discriminates between dyslexic and control readers. The perception of random moving dots activates this area bilaterally in competent readers, but little activation is found in V5 in either hemisphere in dyslexic readers (Eden *et al.* 1996), as Figures 8.7 and 8.8 show. Taken together, these data indicate that dyslexic readers perform worse than normal readers on tasks that require fast sequential processing.

One recent hypothesis suggests that the M pathway plays an important role in selective attention. The reasoning is that the pathway acts as an attentional spotlight that focuses on important stimuli and ignores all the clutter surrounding these stimuli. Vidyasagar and Pammer (1999) asked reading-impaired children and age-matched normal readers to complete a standard visual search task in which they had to locate a stimulus that was characterized by a combination of colour and form (for example, looking for a grey triangle in a background of grey circles). The greater the number of distractors in this task, the

Figure 8.7

The performance of the dyslexic and control groups on the spatial dot task (from Eden *et al.* 1996)

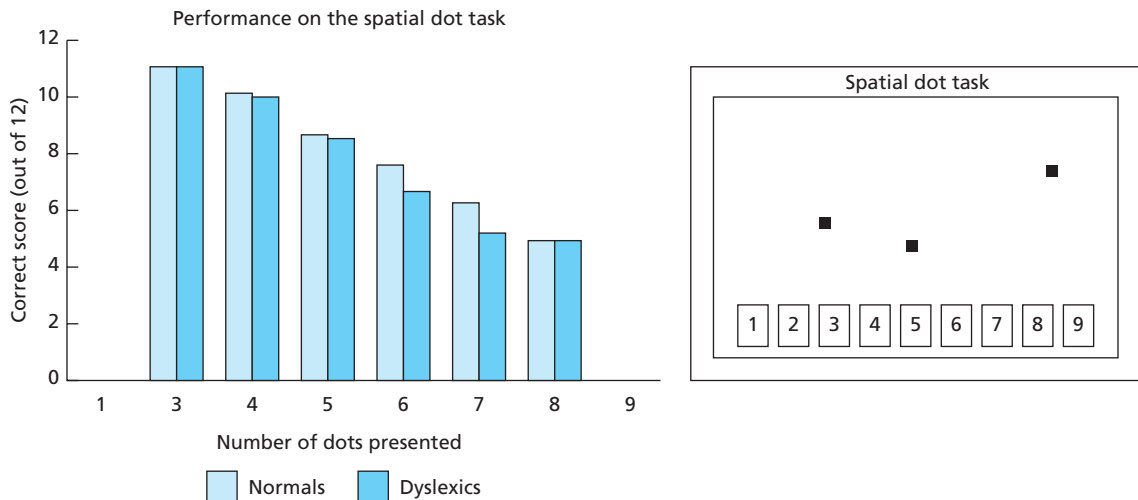
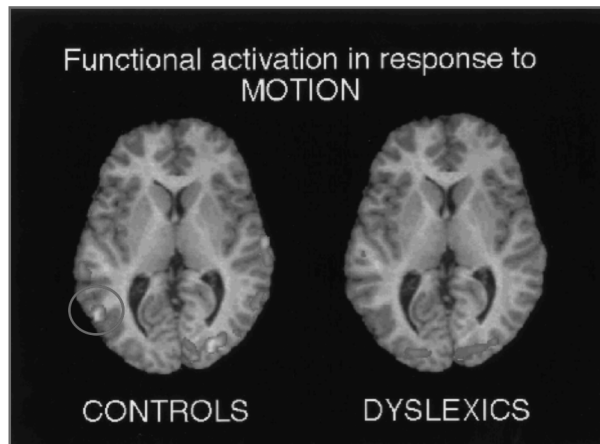

Figure 8.8

The absence of asymmetrical activation in a dyslexic group during motion perception



greater the number of errors made by the reading-impaired group. When there were fewer than thirty-six distractors, the impaired readers did as well as their age-matched counterparts. When the number increased to seventy, a significantly greater number of errors were committed by the impaired reading group, suggesting to the authors that in the dyslexic group, visual search mechanisms are compromised when a visual scene is cluttered. Because reading places great demands on the attentional spotlight – which detects the conjunction of features – an impairment in this process may be explained by deficits in the system that turns on and operates the spotlight.

A study of dyslexic readers with a known M-pathway deficit has shed light on another intriguing feature of dyslexia. A few studies have suggested that the language areas of dyslexic readers are more symmetrically organized in the brain than are those of normal readers. The key region in the left cerebral hemisphere that shows this symmetry is the planum temporale (PT), a small region corresponding to the auditory association cortex in the temporal lobe. This tends to be longer in the left hemispheres of most right-handers, and some researchers have suggested that this region is critical to processing language.

Only a minority of dyslexic individuals experience reading problems purely related to deficient visual processing abilities (Seymour 1986; Felton and Wood 1989; Ramus 2004), and the causal relationship between magnocellular deficit and dyslexia is very unclear (Ramus 2003; Ramus *et al.* 2003). However, there is evidence indicating that dyslexic individuals may suffer impairments in the processing of visual information at some level.

Neuroimaging and dyslexia

Studies of impaired reading and developmental dyslexia using PET and fMRI have found dysfunction in the angular gyrus and the supramarginal gyrus in the inferior parietal cortex and the posterior part of the superior temporal gyrus (i.e. the dorsal pathway to reading) during the performance of auditory rhyming tasks (Rumsey *et al.* 1992; Paulesu *et al.* 1996; Shaywitz *et al.* 1998), complex phonological processing (Shaywitz *et al.* 1998; Georgiewa *et al.* 1999), pronunciation and decision making (Rumsey *et al.* 1997), reading (Horwitz *et al.* 1998; Georgiewa *et al.* 1999; Brunswick *et al.* 1999), and spelling (Flowers *et al.* 1991).

Impaired functioning of the lateral extrastriate cortex and the left occipito-temporal junction (i.e. the ventral pathway to reading) has been found during the silent reading of letter strings (Helenius *et al.* 1999), the passive viewing of concrete and abstract words (Salmelin *et al.* 1996), non-word reading and phonological manipulations (Georgiewa *et al.* 1999), word reading and picture naming (McCrory *et al.* 2005), and explicit and implicit reading (Brunswick *et al.* 1999). Of the many activational anomalies that have been associated with developmental dyslexia, it is this reduced activation of the left hemisphere occipito-temporal region that is considered to be most consistent. (Rumsey *et al.* 1997; Brunswick *et al.* 1999; Paulesu *et al.* 2001; Shaywitz *et al.* 2002; McCrory *et al.* 2005).

In the study by Brunswick *et al.* (1999), dyslexic readers showed a pattern of reduced activation in the left occipito-temporal cortex (BA 37), the cerebellum and the medial lingual/occipital gyrus during an explicit reading task. These regions appear to represent a neural system involved in modality-independent phonological retrieval (Price and Friston 1997). During a task involving implicit reading (participants were asked to make judgements about the physical form of word, pseudoword and false font stimuli), dyslexic readers showed lower levels of activation than control readers in the left hemisphere inferior parietal cortex (BA 40/7) and middle temporal, inferior temporal and posterior occipito-temporal cortices. Reduced activation in the left middle/occipito-temporal region suggests a selective impairment in lexical phonological retrieval (likely to be the source of a primary impairment) in developmental dyslexia (Brunswick *et al.* 1999). Scans from the study can be seen in Plate 1.4.

Of particular importance in this study is the fact that the dyslexic readers and the control readers performed the tasks to an equivalent level of accuracy. Differences in the patterns of neural activation found between the two groups of readers could not therefore be explained in terms of differences in task performance. Similar differences in functional activation, again in the absence of behavioural differences, have been reported since between well-compensated adult developmental dyslexic readers and matched control readers (Brunswick *et al.* 1999; McCrory *et al.* 2000, 2005). This pattern of dysfunction has even been demonstrated in French and Italian dyslexic readers (Paulesu *et al.* 2001). During the performance of tasks involving explicit and implicit reading, these French and Italian dyslexic readers consistently showed a pattern of reduced left hemisphere activation, with a maximum peak in the middle temporal gyrus and additional peaks in the inferior and superior temporal gyri and middle occipital gyrus.

McCrory *et al.* (2005) note that whereas previous studies have reported reduced or absent activation of the occipito-temporal cortex in dyslexic readers relative to control readers, in their picture-naming study they observed activation in the occipito-temporal cortex in both groups of readers. However, the dyslexic readers showed less activation than the control readers. As this region is located between the visual cortex and the anterior temporal cortex, and it has connections to the frontal cortex, it is possible that this is where visual, phonological and semantic information is integrated. Dysfunction of this region therefore might reflect an impairment in this integrative process that might explain the reading and naming deficits of dyslexic readers.

During McCrory *et al.*'s (2000) word/pseudoword repetition study, dyslexic readers showed less activation than control readers in the right superior temporal cortex (BA 22), the right post-central gyrus and the left cerebellum; this was irrespective of word type. Brunswick *et al.*'s (1999) explicit/implicit reading study had previously shown that dyslexic readers activated these regions normally when reading, suggesting that this

observed neural manifestation of dyslexia is task-specific (i.e. functional and not structural). Other studies with normal readers have linked attending to the phonetic structure of speech with a decrease in right hemisphere activity (Zatorre *et al.* 1996). It is, therefore, suggested that in these dyslexic readers, lower right hemisphere activation may indicate less processing of non-phonetic aspects of speech, allowing greater salience to be accorded to phonological aspects of attended speech.

Dyslexia and functional disconnection

In addition to highlighting specific regions of dysfunction within the brains of dyslexic readers, functional imaging studies have provided evidence of poor connectivity within the cortical language systems of these readers. This suggestion was made by Paulesu and colleagues following a study in which they observed striking differences in the pattern of brain activation recorded from adult dyslexic and control readers during the performance of a visual rhyme judgement task and a short-term memory task (Paulesu *et al.* 1996). While control readers activated anterior and posterior language regions (Broca's area and Wernicke's area) and the insula (irrespective of task), the pattern of activation seen in the dyslexic readers was task-dependent: during the memory task they activated only Wernicke's area, and during the rhyming task they activated only Broca's area. In neither condition did they activate the insula. This lack of connection between the anterior and posterior language regions, via the insula, may reflect a lack of automaticity in the processing of language by dyslexic readers.

Horwitz and colleagues similarly reported an absence of activation in the angular gyrus, the inferior frontal region, the fusiform or lingual gyri in dyslexic readers during the performance of various reading tasks (Horwitz *et al.* 1998). Control readers, by contrast, activated the left angular gyrus and extrastriate visual areas in the occipital and temporal cortex (including superior occipital/basal temporal gyri, parts of the lingual and fusiform gyri, part of Wernicke's area and Broca's area) during the reading of pseudo words, and the angular gyrus and the left lingual and fusiform gyri during the reading of low-frequency irregular words. Thus, it would appear that the angular gyrus may be functionally disconnected from the left hemisphere language system in developmental dyslexic readers. Abnormal activation of the angular gyrus is widely reported in dyslexic readers, and while the level of activity in this region is reported to correlate positively with reading ability in unimpaired readers, these two measures correlate negatively in dyslexic readers (Flowers *et al.* 1991; Shaywitz *et al.* 1998).

Anterior language regions, disconnection and compensation

An interesting correlate of this finding of reduced posterior activation in the brains of dyslexic readers during phonological processing is increased activation of inferior frontal regions in these readers (Salmelin *et al.* 1996; Shaywitz *et al.* 1998; Brunswick *et al.* 1999; Pugh *et al.* 2000). These two regions – the occipito-temporal cortex and the left frontal operculum/insula – are normally activated together as part of the modality-independent naming system associated with lexical phonological retrieval. This system is critical either in the specification or the retrieval of phonological information (Price and Friston 1997). It is, therefore, possible that this increased activation of the inferior frontal

cortex may be a by-product of weak connectivity between the anterior and posterior parts of the language system (as reported by Paulesu *et al.* 1996).

It is also possible that this increased frontal activation, along with a similar increase observed in the right hemisphere posterior language regions of dyslexic readers during phonological processing (Shaywitz *et al.* 1998; Pugh *et al.* 2000; Grünling *et al.* 2004), may reflect the implementation of compensatory mechanisms by dyslexic readers to support the impaired functioning of the posterior left hemisphere brain regions that are normally associated with automatic phonological processing. In the right hemisphere regions, this compensation may take the form of non-phonological visual pattern recognition (Shaywitz *et al.* 2002). In the inferior frontal regions, it may be provided in the form of articulatory coding, i.e. the individual may be silently articulating the words to aid them in their performance of the task (Démonet *et al.* 1992; Grünling *et al.* 2004). Thus, these findings support neuropsychological evidence that both dyslexic and control readers employ a common language system for reading but they activate anterior and posterior parts of this system differently, even when reading successfully.

Developmental dyslexia and neurophysiology

Post mortem examinations have revealed structural differences between the brains of good and impaired readers. High concentrations of microdysgenesis (‘disorganized islands of cortex’) have been observed in the left temporo-parietal regions of dyslexic readers’ brains. This concentration is notable in the region of the planum temporale (Galaburda *et al.* 1985; Kaufman and Galaburda 1989; Duane 1989). Although these clusters are not unknown in the brains of normal readers, they are rare and generally occur in the right anterior temporal cortex (Kaufmann and Galaburda 1989). These microdysgeneses seriously disturb the normal pattern of architecture in the brains of dyslexic readers, and they remove the asymmetry normally observed between the enlarged language areas of the left temporo-parietal region and the smaller, homologous areas of the right hemisphere (Galaburda *et al.* 1985). In humans, the capacity for language is generally correlated with a significant development in the magnitude of the left temporo-parietal region and an attrition of neurons in the right hemisphere. These neuronal casualties are part of ‘programmed cell death’ (Brown *et al.* 1994). This particular combination of development and attrition produces the observed asymmetry between corresponding areas in the left and right hemispheres (Geschwind and Levitsky 1968). The relative symmetry in the dyslexic readers’ brains might therefore reflect their impaired linguistic development.

In view of the linguistic impairments and the cortical symmetry that characterize dyslexia, it might be argued that cognitive impairments are the result of a developmental failure of the left hemisphere. This is not necessarily true, however. Physiological symmetries observed in dyslexic readers’ brains may not be the result of smaller than expected left hemisphere regions but of abnormally large cortical regions in the right hemisphere (Galaburda *et al.* 1985; Kaufman and Galaburda 1989). It has been suggested that this symmetry may be due to the unexpected survival of neurons in the right hemisphere – i.e. a failure of the ‘programmed cell death’. The surviving right hemisphere neurons support the left hemisphere’s language-processing functions (Hermann and Zeevi 1991). Alternatively, both phenomena could be the result of reduced intrahemispheric specialization in dyslexic readers, i.e. these individuals’ brains may display less differentiation

between the hemispheres in terms of the type of processing that they mediate. Neither hemisphere is dominant, therefore, for the processing of language (Porac and Coren 1981; Galaburda *et al.* 1985).

Electrophysiological evidence of anterior and posterior abnormalities

EEG studies employing reading-relevant stimuli have associated dyslexia with increased levels of alpha activity in frontal regions during phonological processing (Rippon and Brunswick 1998); in the left frontal, mid-temporal and posterior fronto-central regions during speech perception, reading and the processing of nonsense syllables (Duffy *et al.* 1980); and in the temporo-parietal regions during auditory phonemic discrimination (Ortiz *et al.* 1992). As task-related alpha suppression is associated with attention (Ray and Cole 1985), these findings may indicate reduced 'cortical readiness' in dyslexic readers during these language tasks.

One recent study associated dyslexia in children with significantly increased levels of theta activity in the frontal cortex during phonological processing but not during visual processing. However, control readers showed a task-related decrease in their level of theta (Rippon and Brunswick 2000). The dyslexic readers also showed a marked parieto-occipital asymmetry in beta amplitude (greater in the right hemisphere than in the left), irrespective of task; this contrasted with the task-related amplitude reduction seen in the control readers. Again, these findings seem to reflect differences in cognitive effort and strategy between dyslexic and control readers.

Similar anomalies in dyslexic functional activation have been reported from ERP studies. Such studies, examining interhemispheric differences between good and poor readers in response to visual and auditory linguistic stimuli (e.g. during dichotic listening), have reported evidence of greater symmetry in ERP amplitude (Cohen and Breslin 1984; Brunswick and Rippon 1994) and latency (Sutton *et al.* 1986) in impaired readers than in controls. An example of this can be seen in Figure 8.9. This greater symmetry in ERP amplitude may indicate a lesser degree of hemispheric specialization in the dyslexic readers.

Others have reported reversed ERP (N200 and P200) asymmetries recorded from the temporo-parietal region in dyslexic readers during language processing (Shucard *et al.* 1984); longer N200 latencies in dyslexic readers than in control readers during lexical decision tasks (Taylor and Keenan 1990); longer N140 and N230 latencies in dyslexic readers during auditory and visual recognition tasks (Neville *et al.* 1993); and no inter-hemispheric differences in ERP activation in dyslexic readers during the processing of verbal and non-verbal stimuli (Chayo-Dichy and Ostrosky-Sollis 1990). This symmetry/reversed asymmetry appears to be the result of less involvement of the dyslexic readers' left hemisphere rather than greater involvement of the right. The differences in these waveforms, which occur approximately 100–200 ms after stimulus onset, are interpreted as reflecting differences in sensory/attentional processes in the dyslexic and control readers, even at the earliest stages of visual and auditory language processing.

Dyslexic and control readers are also distinguishable on the basis of later ERP waveforms. Smaller-amplitude/longer-latency P300s, for example, have been observed in dyslexic readers relative to control readers (Taylor and Keenan 1990; Grünling *et al.* 2004). Differences in the P300 waveform, which is associated with stimulus evaluation and memory updating, have been interpreted as reflecting inefficient cognitive processing by dyslexic readers and an ineffective allocation of attentional resources (see Rüsseler *et al.* 2003).

Figure 8.9

(a) ERPs from dyslexic readers undertaking a phonological task; (b) ERPs from reading-age-matched controls during performance of the same task

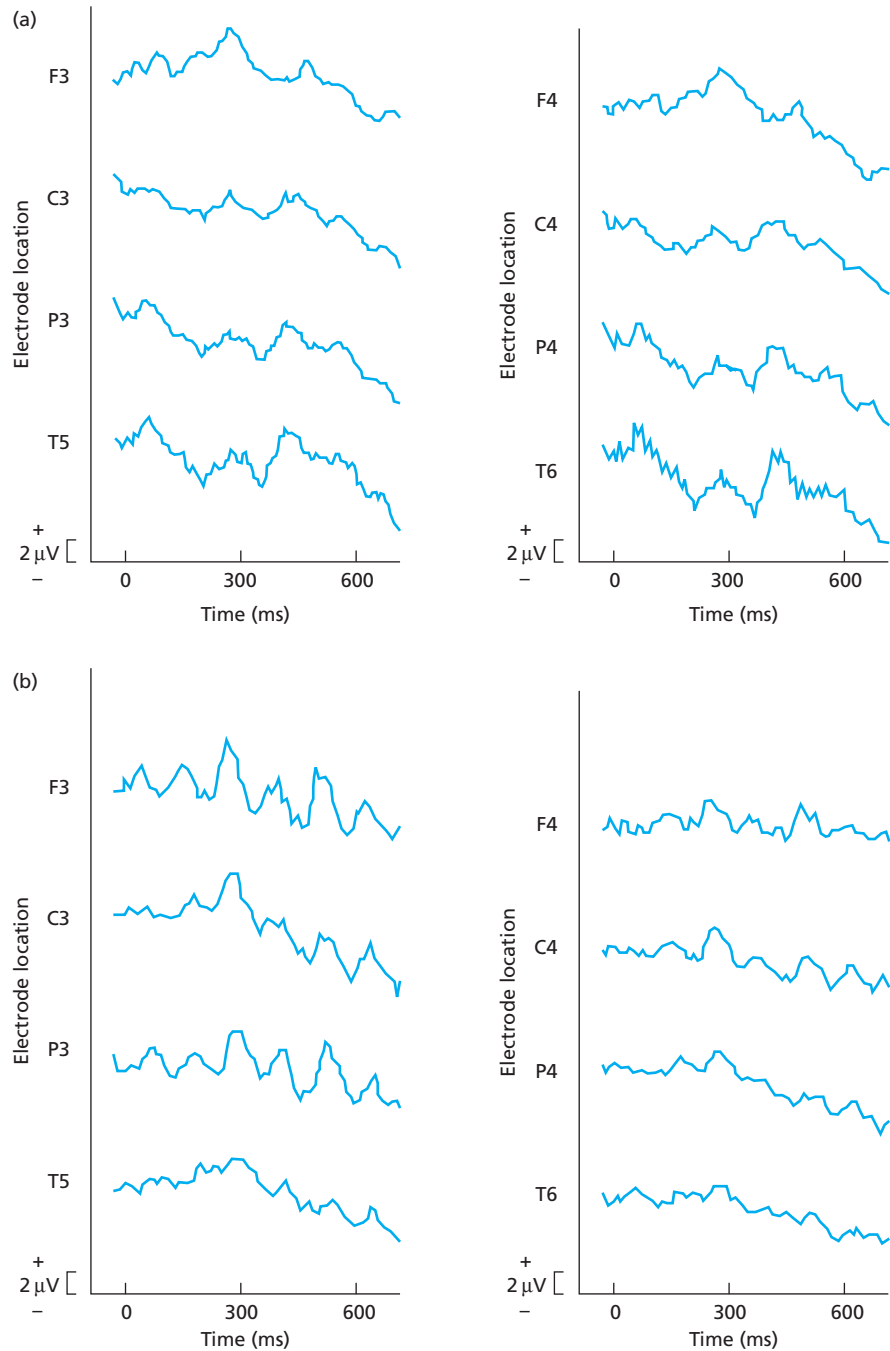

Discussion point: do deficits in the cerebellum cause dyslexia?

The past decade has seen a profusion of studies linking irregular brain structure or function to reading disorders such as developmental dyslexia. A new line of research has focused on the cerebellum: its anatomy and activity appear to be markedly different in people with developmental dyslexia. But is this irregularity a meaningful symptom or cause of the disorder, or simply an artefact?

The cerebellum is best understood as the region that contributes to motor function, posture and balance. However, recent research also implicates it in a variety of non-motor functions, such as reading, speech perception and even emotional expression (Desmond 2001; Justus and Ivry 2001). Damage to the region results in impairments in grammatical morphology, as the examples in Table 8.4 show.

The first case study, of an Italian patient, reported reduced verbal fluency and deficient grammar in speech (Silveri *et al.* 1994). Subsequent case studies have replicated these findings, and a recent study of sixteen patients with cerebellar damage found that the number of words used when describing pictures was at normal levels in these patients, but they had significant problems with deciding whether aurally presented sentences were natural and correct or incorrect and unnatural (Justus 2004). Examples of these sentences included ‘the writer were holding a very big party’, and ‘the artists were selling several small but expensive watercolour paintings’. Those where agreement between subject and verb was anomalous posed especial problems.

In a study of six dyslexic men and age-matched controls, Nicolson *et al.* (1999) found that activation in the cerebellum was significantly lower in the dyslexic than in the normal reading group during the execution of familiar and novel motor tasks. The authors suggest that this cerebellar dysfunction affects the learning of new skills and the ‘performance of automatic, overlearned skills’. Reading, they argue, is a complex behaviour composed of a range of interacting motor behaviours that need to be learned and improved over time. The dysfunctional cerebellum is not a cause of dyslexia but is a key structure in dyslexia.

Table 8.4 Some grammatical errors made by patients with cerebellar damage

Italian patient (translation): I was watching [the] television. One moment after, immediately after, to feel one-half not to go. To have an attack, to be unable to speak. Upstairs there was my wife sleeping because it was midnight. I suddenly to stand up, suddenly to fall down. Not to do anything because there was the carpet ...

Silveri *et al.* (1994)

Italian patient (translation): Razor hand. First there was razor and brush. A brush was used now instead spray. Foam on the hands then palm cream razor hand I do like this. I repeat operation against the growth. Same blade twice. Or electric razor. Face well dry. To use before pre-shave lotion. Batteries or current same thing. But electric razor skin used to must be.

Zettin *et al.* (1997)

Source: adapted from Justus 2004.

Beaton (2002) reviews a sizeable number of hypotheses regarding the cause of dyslexia, including one suggesting that the disorder represents a failure to perform a skill automatically (rather than consciously). The original authors of this hypothesis argue that this failure in automaticity is linked to the integrity (or otherwise) of the cerebellum.

On the surface, there seems to be some evidence for this association. A recent experiment correlated the brain structure of dyslexic children who had poor reading skill but superior verbal intelligence with reading performance, using MRI. Smaller right-sided reduction in the front of the cerebellum correctly predicted over 72 percent of children with dyslexia: that is, the reduction in the region was correlated with poor reading (Eckert *et al.* 2003). According to the authors, this and other studies show that 'the cerebellum is one of the most consistent locations for structural differences between dyslexic and control participants in imaging studies'. The consistency is important, because many other regions also show irregularity in dyslexic participants in imaging studies.

In a separate study, Rae *et al.* (2002) found that the side of the cerebellum that controlled the writing hand was less well developed in dyslexic adults than in controls. However, as Bishop (2002) argues, the development of the cerebellum depends on the degree of experience a person has with writing: a child with literacy problems is less likely to pick up a pen and use it frequently. Consequently, the cerebellum does not show the same strength of development seen in individuals who have a history of well-practised writing.

This alternative interpretation suggests that the irregularity in the cerebellum is not due to dysfunctional development related to a reading disorder but simply due to a lack of practice in writing (which affected how the cerebellum developed). 'If we find a cerebellar abnormality in dyslexia', Bishop cautions, 'the temptation is to assume it is instrumental in producing reading difficulties. However, the cerebellum shows considerable plasticity, and can be influenced by, as well as influence, cognitive and behavioural deficits' (p. 496).

A model of reading, and some neuropsychological evidence

One of the most influential theories of reading suggests that it relies on two different 'routes', which are separate and distinct. This model, the dual-route model of reading, suggests that one, indirect, route 'translates' written language into sounds via grapheme-phoneme correspondence rules (the grapho-phonological route) while another, direct, route helps to 'translate' those words that do not follow grapheme-phoneme correspondence rules (the lexico-semantic route).

Using the first route, the reader can pronounce words that follow regular language and access their meaning; using the second, the reader matches the word directly with one already stored and subsequently accesses its meaning. Because some words may not follow normal spelling-to-sound rules, the model suggests that such words are stored as whole visual forms, a little like images. The more frequent the encounters with irregularly spelled words, the more direct and efficient the lexico-semantic route is. These whole word forms are stored in what has been called the orthographic lexicon. Even parts of a word may be sufficient for it to be recognized as a whole unit.

This model is derived from studies of patients who, following brain injury, appeared to rely more on one route than the other. People with phonological dyslexia, for example, appeared to have access only to whole word forms (the direct route) and had difficulty in reading regularly spelled words (suggesting an impairment in the indirect route).

However, another model argues that the same mechanisms underlie the reading aloud of words and non-words (such as *nep* and *cabe*). The dual-route model does not explicitly describe a route for the reading of non-words. A test of these two models would be phonological dyslexia, a reading impairment in which the reading of non-words is significantly worse than the reading of (familiar) words. It can result from brain damage in adults, but there is evidence of a developmental form in children. Caccappoulo-van Vliet *et al.* (2004) have described two individuals with Alzheimer's disease who showed pure phonological dyslexia. While they were unable to read non-words but able to read familiar, irregularly spelled words accurately, these patients' phonological skills were intact. The findings support the dual-route model explanation of phonological dyslexia, which argues that the disorder derives from an impaired ability to convert unfamiliar letters to sounds. The findings appear not to support the alternative model, because in the two patients studied, phonological ability was generally unimpaired.

A recent meta-analysis of neuroimaging and the dual-route model has suggested that the two routes of reading can be mapped in the healthy brain (Jobard *et al.* 2003). The analysis examined thirty-five neuroimaging studies of real word and pseudoword reading in healthy participants. While the reviewers found that access to the visual representation of words relied on two routes, they also noted that there was no consistent brain region devoted to storing the shapes of word forms. Instead, they found that a general region appeared to be involved in the initial segmentation or classification of word-like stimuli. This region was located at the occipito-temporal junction. The phonological route was subserved by parts of the temporal lobe and also regions involved in working memory (because of the processes involved in matching letters and sounds). The so-called direct route, according to this review, would recruit a pathway linking the occipito-temporal cortex with those involved in semantic processing (these regions are found in or around the temporal cortex).

Discussion point: which brain regions are necessary for reading? Two case studies of acquired dyslexia with neuroimaging

Since the first neuroimaging study of human language in 1988, a large number of investigations has reported areas of brain activation during the processing of different types of language task. These neuroimaging data have helped to do two things: (1) to confirm the region responsible for individual function as suggested by studies of brain damage; and (2) together with single-case studies, constrain theories of cognition and reading. There is significant overlap between neuroimaging and lesion data in what they reveal about localization of specific language processes. However, in neuroimaging experiments, it is unclear whether the activation in specific regions is *necessary* for the aspects of language processing studied. According to Price *et al.* (2003), one method of determining the necessity of these areas is to examine lesion data and investigate whether lesions to different areas are associated with different deficits.

Price *et al.* used fMRI to study two patients with acquired dyslexia. One patient had damage to all the left temporal regions that are activated during normal reading. He was able to read some highly imageable words but was unable to read pseudowords and made meaning errors when reading others (saying 'wrong' when trying to read the word 'error'). The pattern is consistent with deficits seen in deep or phonological dyslexia and suggests that the patient relies on semantics when translating written

words into sounds. The second patient also showed left temporal lobe damage, but the lesion did not affect the superior temporal lobe (but did affect the inferior and anterior region). She could read regular words and most pseudowords but had greater difficulty in reading irregularly spelled words, a pattern typical of surface dyslexia. She had difficulty in reading words that required semantic processing, suggesting that the areas damaged might be important for semantic processing.

The first patient was asked to read highly imageable words during scanning; the second was asked to read one of a triad of regular three-letter words. For example, the word BUS would appear under two identical words. The first patient showed activation in all the language areas one would expect to be activated during normal reading, except for the area damaged. The second patient activated all the typical language areas but showed a reduction in areas associated with semantic processing. On the basis of these single-case studies, Price *et al.* suggest that translating written words into sounds is mediated by the left mid-fusiform gyrus in the temporal cortex. But when semantic processing is impaired, the posterior part of this region and left frontal areas try to undertake the function of translating the written word into phonology via semantics.

Dysgraphia/agraphia

The ability to process word sounds and the possession of a knowledge of syntax and grammar are crucial to supporting the production, perception and interpretation of written language. Agraphia is the loss of the ability to produce written language, secondary to a CNS disorder. Dysgraphia describes an impairment of this ability, although the terms ‘agraphia’ and ‘dysgraphia’ are used interchangeably (Weekes and Coltheart 1996). The disorder often accompanies dyslexia, although it is sometimes seen in the absence of other language impairments (Thomas-Anterion *et al.* 1994). Dysgraphic difficulties are not motor problems, because the individual typically retains the ability to produce the movements necessary for writing. Instead, they are seen as spelling impairments – the inability to translate spoken words into their written form.

Articulating sounds or scanning the visual form of the word is important for spelling, as demonstrated by an attempt at writing a word such as ‘anthropological’ while repeating the word ‘the’ subvocally. Rather than relying on phonological processes, spelling may still be achieved by visualizing the word to be spelled. Even when a word has been spelled phonetically, visual processes may still be employed in the case of ambiguous spellings, to check that the word ‘looks right’. As with the dyslexias, there are distinct and discrete dysgraphic syndromes: these are outlined in Table 8.5.

Phonological dysgraphia

Phonological dysgraphia describes the inability to spell phonetically. Individuals retain the ability to employ visual strategies to mediate their spelling of real words, although spelling of pseudowords is not possible (Shallice 1981). As with phonological dyslexia, phonological dysgraphia is associated with damage to the superior temporal lobe (Benson and Geschwind 1985).

Table 8.5 Types of agraphia, their primary symptoms and the brain regions associated with them

Type of agraphia	Primary symptoms	Brain regions implicated
Phonological agraphia	Deficient spelling of non-words, real words are spelled 'visually'.	Superior temporal lobe.
Orthographic (surface) agraphia	Impaired spelling of irregular words, regular words and non-words are spelled phonetically.	Inferior parietal lobe.
Deep agraphia	Inability to spell phonetically, tendency to make semantic substitutions.	Extensive left hemisphere damage.

Orthographic (surface) dysgraphia

Conversely, individuals who lose the ability to spell via visual processes have great difficulty in spelling irregular words such as 'yacht' or 'enough'. However, they are able to invoke phonological strategies to facilitate the spelling of regular words and nonsense words (Beauvois and Derouesne 1981). This is called orthographic or surface dysgraphia. Indeed, people with this type of dysgraphia seem to be overly dependent on grapheme–phoneme conversion and show impairment in the ability to spell at the level of the whole word. Orthographic (surface) dysgraphia is seen in individuals with damage to the inferior parietal lobe (Benson and Geschwind 1985).

Deep dysgraphia

An alternative form of dysgraphia, deep dysgraphia, mirrors deep dyslexia in that it involves a loss of the ability to spell phonetically and the tendency to replace dictated real words with semantically related words, e.g. writing 'cake' in response to the word 'bun' (Newcombe and Marshall 1980). If asked to spell a dictated non-word, a person with deep dysgraphia would typically produce a real word that is similar in sound to a semantically related real word, producing 'flower', for example, in response to the dictated non-word 'blom', possibly via the word 'bloom' (Bub and Kertesz 1982). The ability to recognize orally spelled words is also lost, although, somewhat surprisingly, individuals with deep dysgraphia retain the ability to read and repeat words and non-words that they can no longer spell (Cipolotti and Warrington 1996). As with deep dyslexia, deep dysgraphia is associated with extensive damage to the dominant hemisphere (Cossu *et al.* 1995; Cipolotti and Warrington 1996).

Summary

Clinical and brain-imaging data suggest that speech production and comprehension are mediated by two different regions in the left hemisphere. The anterior language region (Broca's area), next to the motor cortex in the left hemisphere, is thought to be responsible

for the mediation of language production. The posterior language region (Wernicke's area), located above the temporal gyrus and the planum temporale in the left hemisphere, mediates language comprehension. At a subcortical level, the left ventro-lateral and pulvinar nuclei of the thalamus have been implicated in coordination of the activity of the cortical language regions. Studies suggest that (1) semantic processing may be mediated by the left frontal cortex, (2) the discrimination of orthographically legal letter strings from orthographically illegal letter strings is mediated by the left posterior extrastriate cortex, and (3) phonological processing – the ability to manipulate the component sounds within words – is mediated by the posterior temporal cortex of the left hemisphere and Broca's area. Aphasia describes the inability to produce or comprehend language. Subtypes of aphasia are characterized by deficits in comprehension and word retrieval with preserved language production abilities (sensory aphasia); telegraphic speech with abnormal prosody and syntactic ambiguities but normal comprehension (production aphasia); normal comprehension and production but impaired naming of objects and repetition of non-words (conduction aphasia); the tendency to replace visually presented words with semantic associates (deep aphasia); impaired comprehension, naming, reading and writing (transcortical sensory aphasia); periods of transient mutism interspersed with telegraphic, dysprosodic speech (transcortical motor aphasia); and generalized comprehension, repetition, speech production and naming deficits (global aphasia). Dyslexia refers to an impairment in the ability to read. There are two principal subdivisions: acquired dyslexia, the loss of previously normal reading skills following brain damage, and developmental dyslexia, a difficulty experienced in learning to read with a presumed neurological basis. Types of acquired dyslexia include visual word form dyslexia (an impairment in sight reading although some decoding of words is possible), phonological dyslexia (an impairment in the reading of pseudowords and non-words), surface dyslexia (impaired ability to read words 'visually' and over-reliance on decoding strategies, which leads to frequent regularization errors), and deep dyslexia (severe inability to read non-words and abstract words and the tendency to replace seen words with semantically related associates). Visual word form dyslexia is found in individuals with damage to the connections between the left hemisphere's angular gyrus and the visual input system. Lesions of the dominant temporal lobe may underlie acquired phonological dyslexia, just as abnormal development of the temporo-parietal region of the left hemisphere is implicated in developmental dyslexia. The precise locus of damage associated with deep dyslexia is not yet clearly defined, although the damage appears to be extensive in the dominant hemisphere. Little is known about the lesions responsible for surface dyslexia.

Recommended further reading

The neuropsychology of language: normal aspects

- Aboitiz, F. and Garcia, R.V. (1997). The evolutionary origin of the language areas in the human brain: a neuroanatomical perspective. *Brain Research Reviews*, 25, 381–96.
- Billingsley-Marshall, R.L., Simos, P.G. and Papanicolaou, A.C. (2004). Reliability and validity of neuroimaging techniques for identifying language-critical areas in children and adults. *Developmental Neuropsychology*, 26, 2, 541–63.
- Caplan, D. (2001). Functional neuroimaging studies of syntactic processing. *Journal of Psycholinguistic Research*, 30, 297–320.
- Gernsbacher, M.A. and Kaschak, M.P. (2003). Neuroimaging studies of language production and comprehension. *Annual Review of Psychology*, 54, 91–114.

- Hillis, A. (2002). *New Techniques for Identifying the Neural Substrates of Language*. Hove, UK: Psychology Press.
- Jobard, G., Crivello, F. and Tzourio-Mazoyer, N. (2003). Evaluation of the dual route theory of reading: a metaanalysis of 35 neuroimaging studies. *Neuroimage*, 20, 693–712.
- Joubert, S., Beaugregard, M., Walter, N., Bourgouin, P., Beudoin, G., Leroux, J.-M., Karama, S. and Lecours, A.R. (2004). Neural correlates of lexical and sublexical processes in reading. *Brain and Language*, 89, 9–20.
- Josse, G. and Tzourio-Mazoyer, N. (2004). Hemispheric specialization for language. *Brain Research Reviews*, 44, 1–12.
- Paulesu, E., McCrory, E., Menoncello, L., Brunswick, N., Cappa, S.F., Cotelli, M., Cossu, G., Corte, F., Lorusso, M.L., Pesenti, S., Perani, D., Gallagher, A., Fazio, F., Price, C., Frith, C.D. and Frith, U. (2000) A cultural effect on brain function. *Nature Neuroscience*, 3, 1, 91–6.
- Special issue of *Brain and Language* on ‘Language and motor integration’, 2004, 89, 2.
- Special issue of *Cognition* on ‘Towards a new functional anatomy of language’, 2004, 92, 1–2.
- Vanlancker-Sidtis, D., McIntosh, A.R. and Grafton, S. (2003). PET activation studies comparing two speech tasks widely used in surgical mapping. *Brain and Language*, 85, 245–61.
- Wise, R.S.J., Scott, S.K., Blank, S.C., Mummery, C.J., Murphy, K. and Warburton, E.A. (2001). Separate neural subsystems within ‘Wernicke’s area’. *Brain*, 124, 83–95.

Aphasia

- Behrmann, M. and Patterson, K. (2004). *Words and Things: Cognitive Neuropsychological Studies in Tribute to Eleanor M. Saffran*. Hove, UK: Psychology Press.
- Berndt, R.S. (2001). *Language and Aphasia*. Oxford: Academic Press.
- Boatman, D. (2004). Cortical bases of speech perception. Evidence from functional lesion studies. *Cognition*, 92, 47–65.
- Dell, G.S. and Sullivan, J.M. (2004). Speech errors and language production: neuropsychological and connectionist perspectives. *The Psychology of Learning and Motivation*, vol. 44, 63–108.
- Funnell, E. (2000). *Case Studies in the Neuropsychology of Reading*. Hove, UK: Psychology Press.
- Grodzinsky, Y. (2000). The neurology of syntax: language use without Broca’s area. *Behavioural and Brain Sciences*, 23, 47–117.
- Hale, S. (2003). *The Man who Lost his Language*. London: Penguin.
- Hillis, A. (2002). *The Handbook of Adult Language Disorders*. Hove, UK: Psychology Press.
- Price, C.J., Gorno-Tempini, M.L., Graham, K.S., Biggio, N., Mechelli, A., Patterson, K. and Noppeney, U. (2003). Normal and pathological reading: converging data from lesion and imaging studies. *Neuroimage*, 20, S30–S41.
- Wise, R.S.J., Scott, S.K., Blank, S.C., Mummery, C.J., Murphy, K. and Warburton, E.A. (2001). Separate neural subsystems within ‘Wernicke’s area’. *Brain*, 124, 83–95.

Dyslexia

- Beaton, A.A. (2002). Dyslexia and the cerebellar deficit hypothesis. *Cortex*, 38, 479–90.
- Beaton, A.A. (2004). *Dyslexia, Reading and the Brain*. Hove, UK: Psychology Press.
- Bishop, D.V.M. (2002). Cerebellar abnormalities in developmental dyslexia: cause, correlate or consequence? *Cortex*, 38, 491–8.
- Brunswick, N. (2004) Developmental dyslexia: evidence from brain research. In T. Nunes and P. Bryant (eds), *Handbook of Literacy*. Dordrecht, The Netherlands: Kluwer Press.
- Brunswick, N., McCrory, E., Price, C., Frith, C.D. and Frith, U. (1999). Explicit and implicit processing of words and pseudowords by adult developmental dyslexics: a search for Wernicke’s Wortschatz? *Brain*, 122, 1901–17.

- Demonet, J.F., Taylor, M.J. and Chaix, Y. (2004). Developmental dyslexia. *The Lancet*, 363, 1451–60.
- Caccappoulo-van Vliet, E., Miozzo, M. and Stern, Y. (2004). Phonological dyslexia: a test case for reading models. *Psychological Science*, 15, 9, 583–90.
- Coltheart, M. *et al.* (1993). Models of reading aloud: dual-route and parallel distributed processing approaches. *Psychological Review*, 100, 589–608.
- Coltheart, M., Patterson, K. and Marshall, J.C. (1980). *Deep Dyslexia*. London: Routledge & Kegan Paul.
- Eckert, M. (2004). Neuroanatomical markers for dyslexia: a review of dyslexia structural imaging studies. *The Neuroscientist*, 10, 4, 362–71.
- Eckert, M.A., Leonard, C.M., Richards, T.L., Aylward, E.H., Thomson, J. and Berninger, V.W. (2003). Anatomical correlates of dyslexia: frontal and cerebellar findings. *Brain*, 126, 482–94.
- McCrory, E., Frith, U., Brunswick, N. and Price, C. (2000). Abnormal functional activation during a simple word repetition task: a PET study of adult dyslexics. *Journal of Cognitive Neuroscience*, 12, 5, 753–62.
- Paulesu, E., Frith, U., Snowling, M., Gallagher, A., Morton, J., Frackowiak, R.S.J. and Frith, C.D. (1996). Is developmental dyslexia a disconnection syndrome? *Brain*, 119, 143–57.
- Special issue of *Cortex* on 'Neurobiology of developmental disorders', 2005, 41, 3.
- Stein, J. and Walsh, V. (1997). To see but not to read; the magnocellular theory of dyslexia. *Trends in Neurosciences*, 20, 147–52.
- Turkeltaub, P.E., Gareau, L., Flowers, D.L., Zeffiro, T.A. and Eden, G.F. (2003). Development of neural mechanisms for reading. *Nature Neuroscience*, 6, 6, 767–73.

9

Memory

- Memory defined
- Before memory: learning
- Where are long-term memories formed?
- Chemical modulation of LTP
- Amnesia
- Diencephalon
- Encoding and retrieval in episodic and semantic memory
- Working memory
- The neurochemical basis of working memory
- Spatial navigation and memory
- Are memory processes lateralized?
- Summary
- Recommended further reading

Memory defined

Memory and learning are probably the most difficult human functions to localize in the brain, principally because memory is a process and not a single ‘entity’ or thing. The process involves multifarious components – encoding, retrieval, recall, recognition – and multifarious modalities, such as visual, olfactory and auditory. Added to this, there is more than one distinct type of memory process, and various psychologists have argued for the existence of different dichotomies in memory.

James (1890) was one of the earliest. He distinguished between two types of memory based on the temporal properties of the material to be recollected: he described memory for short-term processing as ‘primary memory’ and the long-term processing and storage of material as ‘secondary memory’. In 1958, Broadbent made James’s dichotomy more explicit by specifically postulating a short-term (STM) and long-term memory (LTM) process in which items from STM would, via specific mechanisms, make their way into LTM.

The current memory literature is dominated by similar but more fractionated dichotomies of the memory process. One popular division is that represented by declarative and procedural memory (Cohen and Squire 1980). Declarative memory refers to the recall and recognition of facts that are accessible to conscious recollection (the facts from this book, for example); procedural memory refers to the process involved in those skills and automatic operations needed to perform a certain physical, learned function (e.g. the motor skills required for typing a letter or riding a bike). Declarative memory is similar to explicit memory – the process of recalling material that is deliberately learned and retrieved; it represents the conscious learning or memorization of material. (Conversely,

implicit memory refers to the recall of material that is not deliberately encoded or retrieved but is done so 'incidentally'. For example, presenting a series of words to participants and then asking them to complete a series of word stems is an example of implicit memory: participants are not told to complete the stems using words previously presented.)

According to Squire (1994), declarative memory 'refers to a biologically meaningful category of memory dependent on a specific brain system'. However, some forms of memory clearly do not fit the description of declarative memory, but neither do they fit the definition of procedural memory particularly well. A broader term, 'non-declarative memory', has been used to describe those abilities not fitting the other description (Squire and Zola-Morgan 1988). This is similar to Schacter's (1987) conception of implicit memory: memory that involves no explicit or conscious intention to learn or memorize. According to Schacter, implicit memory 'embraces several kinds of memory and depends on multiple brain systems'. As memories rely on information received by several sensory systems, this process would suggest that memory has multiple components or is subserved by multiple memory systems. The current view in neuropsychology is that this is the case.

A further psychological distinction is seen between episodic (autobiographical) and semantic (knowledge) memory. Episodic memory represents memories that are personally meaningful (such as meeting your favourite actor or remembering your summer holiday), whereas semantic memory refers to memories based on knowledge of events, people or places, such as knowing that Tony Blair was prime minister of the United Kingdom, but Neil Kinnock was not.

In addition to the episodic versus semantic dichotomy, there is also a specific memory process called working memory, described in Chapter 5. Working memory is not short-term memory but rather what we do with material in short-term memory. Working memory is what allows us to undertake one task while keeping another in mind. Experimentally, one of the most widely used tests of working memory is the reading span task (Daneman and Carpenter 1980). One version of the test involves asking people to read aloud sentences and to verify how truthful they are while trying to remember the last word of each sentence. This task, like many others of working memory, requires a person to maintain some information in memory (storage) while simultaneously manipulating other information (processing).

Some have argued that working memory may be isomorphic (i.e. to all intents and purposes, synonymous) with general intelligence or *g* (Kyllonen 2002), although the evidence for this is not strong (Ackerman *et al.* 2005). In their meta-analysis of eighty-six samples of working memory and intelligence test scores, Ackerman *et al.* suggest that correlations between working memory test performance and intelligence test performance are not high (but higher than those between STM and *g*) and that it is a domain-specific construct. However, others have reviewed the data differently and argued that working memory and *g* are very highly correlated (Kane *et al.* 2005; Oberauer *et al.* 2005). The conclusion appears to be that while the two constructs are not the same, working memory can be a highly significant predictor of reasoning and fluid intelligence.

Working memory is thought to comprise three parts: the phonological loop, which stores verbal information; the visuospatial scratchpad, which stores visuospatial information; and a central executive, which coordinates the activity of the two (Baddeley and Hitch 1974; Baddeley 1986; Baddeley and Logie 1992). People have likened the central executive to the function of the frontal lobes, which, as you saw in Chapter 5, coordinate our ability to sequence and plan behaviour.

There is evidence that the different types of memory process described here recruit specific regions and systems and that damage to these systems can produce specific types of memory problem. This chapter describes some of these problems, the areas thought to be responsible for encoding and retrieval, and the different types of memory.

Before memory: learning

Before material can be remembered (and forgotten), it must first be learned. Learning involves three basic processes: the acquisition of material, its consolidation and its retrieval. Retrieval can involve free recall, where the participant is asked to remember previously presented stimuli, unaided by cues, or recognition, where the participant has, for example, to determine which of two stimuli had been presented previously (where one stimulus is a distractor and not experienced before and the other is the stimulus previously seen/heard/etc.).

Two basic types of learning have been identified. During instrumental learning, the organism identifies a link between a stimulus and the response. It learns that by making a certain number of behavioural responses or making these responses at certain intervals, it will be rewarded (or reinforced; the reward reinforces the behaviour and encourages it to be repeated to achieve the same outcome). In classical conditioning, an organism learns that if two previously unassociated stimuli are paired often enough, then the response normally elicited by the first will also be elicited by the other (although before they were paired, it would not have done this). The classical example is Pavlov's dogs: when seeing food, the dogs salivated; when hearing the sound of a bell, they did not. When the presentation of food was paired with a bell, the dog would still salivate. When the food and bell were paired repeatedly and the dog was eventually exposed to the sound of the bell alone, it salivated. The dog had learned to associate the bell with the delivery of food. In this example, the food is the unconditioned stimulus and the salivation to the food the unconditioned response. The bell is the conditioned stimulus, and the salivation to the bell alone is called the conditioned response. Neuropsychologists have used classical conditioning to explore not only how we learn (and the neural basis of this learning) but also how we learn to become afraid of objects and people (as Chapter 10 describes).

Learning seems to involve a strengthening of connections between neurons. The theory was proposed by Hebb (1949) in his famous book, *Organisation of Behaviour*. Hebb proposed that each psychologically important event is conceived of as the flow of activity in a neuronal loop. This loop is made up of the interconnections between dendrite, cell body and the synapses on these structures. The synapses in a particular path become functionally connected to form what Hebb called a cell assembly. The assumption he made was that if two neurons are excited together, they become linked functionally. If the synapse between two neurons is repeatedly activated as the postsynaptic neuron fires, then the structure or chemistry of the synapse changes. This change strengthens the connection between neurons.

Hebb proposed that short-term memory resulted from reverberation of the closed loops of the cell assembly; long-term memory is the more structural, lasting change in synaptic connections. This long-term change in structure is thought to reflect long-term potentiation (LTP), a term that describes the strengthening of neuronal connections via repeated stimulation (Lomo 1966). Lomo found that if the axonal pathway from the entorhinal cortex to the dentate gyrus of the hippocampus was repeatedly stimulated electrically,

there was a long-term increase in the size of potentials generated by the postsynaptic neurons. LTP was therefore produced by the activation of synapses and the depolarization of postsynaptic neurons. Psychologists agree that long-term memory involves more or less permanent changes in the structure of the brain: but where and how?

Where are long-term memories formed?

Long-term potentiation seems to predominate in the hippocampus: if the hippocampus is stimulated, long-term physical changes are observed (Bliss and Gardner-Medwin 1973). The entorhinal cortex provides inputs to the hippocampus. The axons from the entorhinal cortex pass through a part of the subcortex called the perforant path and form synapses with cells in the dentate gyrus, a part of the hippocampal formation.

The hippocampal formation itself is composed of two distinct structures: Ammon's horn (often referred to as the hippocampus) and the dentate gyrus. Ammon's horn comprises the substructures CA1, CA2 and CA3. CA1 is sometimes referred to as 'Sommer's sector'. There is also significant hippocampal output to the mammillary body via a tract called the fornix. Damage to each of these structures is sometimes associated with memory loss, although the evidence for the involvement of the fornix is mixed (Calabrese *et al.* 1995).

Translating this process into the behaviour seen in classical conditioning, the unconditioned stimulus (the puff of air) makes strong synaptic connections with the neurons that produce the unconditioned response (the blink). Presenting the conditioned stimulus (the tone) alone generates weak synapses, but pairing the tone with the unconditioned stimulus leads to the conditioned stimulus forming very strong synaptic connections. The more often the pairing is made, the stronger the connection becomes. For this type of classical conditioning to occur, a functioning hippocampus appears to be necessary, and the involvement of the structure would appear to be that of acquiring conscious knowledge of the relationship between the conditioned and unconditioned stimulus. The hippocampus is also involved in learning the relationship between the unconditioned and conditioned stimulus when there is a delay between the presentation of each, a process called trace conditioning (Clark and Squire 1998).

Figure 9.1

The lifespan of learning consolidation (from Meeter and Murre 2004. American Psychological Association, reprinted with permission)

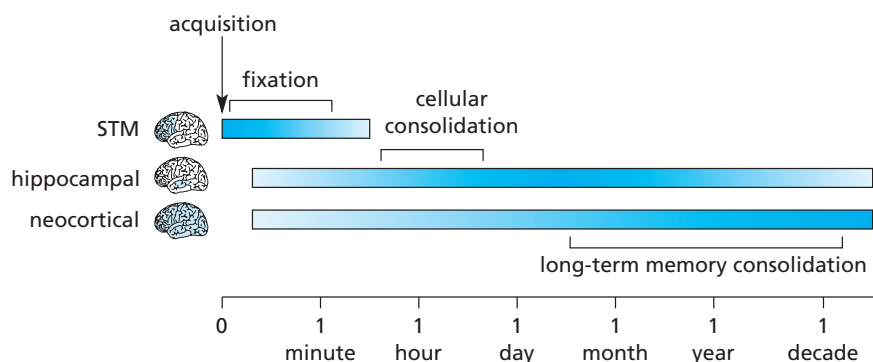

The consolidation of memory seems to be time-dependent. For example, the initial period and the few hours after the learning of UCS and CS pairings appears to be the moment when memory is consolidated. Therefore, interruption of the process at these times will impede consolidation (Bourtchouladze 1998). The first period of consolidation may be dependent on a different neurotransmitter system to that involved in the second. These are the NMDA and dopaminergic systems, respectively. The time-course of learning consolidation can be seen in Figure 9.1.

Chemical modulation of LTP

The most important excitatory neurotransmitter in the nervous system is glutamic acid or glutamate. One subtype of glutamate, *N*-methyl-D-aspartate (NMDA), appears to be important for producing long-term potentiation (Abel and Lattal 2001). NMDA receptors are found in the CA1 sector of the hippocampus, and blocking activity in NMDA receptors prevents long-term potentiation in CA1 and the dentate gyrus. Blocking activity does not prevent or reverse LTP that has already occurred. The key process is the entry of calcium ions through ion channels, a phenomenon mediated by NMDA receptors.

When calcium enters an ion channel, changes in the structure of the neuron are produced by an enzyme called a calcium-dependent enzyme (CDE; Lynch *et al.* 1988). One CDE is called calpain, which breaks down proteins in the spines of dendrites. Without this entry of calcium, LTP does not occur. Weak synapses, resulting from weak activation, do not lead to depolarization, which allows calcium ions to enter ion channels. Strong synapses that are activated do lead to this polarization, suggesting that the NMDA receptor is vital for the process of learning acquisition (Steele and Morris 1999).

However, LTP can occur in other parts of the brain apart from the hippocampus, and not all forms of LTP involve the NMDA receptors. So, although the hippocampus and the NMDA receptors seem to be prime mechanisms for LTP, they may not be the only ones. There are structures such as the amygdala, for example, that are involved in the conditioning of fear. Temporarily inactivating part of the amygdala, for example, can impair an organism's ability to learn to fear, whereas inactivating the same area after conditioning has taken place still results in a fear response in the organism (Wilensky *et al.* 2000). This finding suggests that this part of the amygdala may be involved in the acquisition, but not consolidation, of memory. The topic of fear conditioning is described and evaluated in more detail in Chapter 10.

One of the most important findings in the physiology of memory in recent decades has been that the hippocampal formation is essential for the formation or learning of new memories but may not be involved in the long-term retention or retrieval of memory (Shors 2004). What is unclear is why this dissociation should be.

Two recent studies have shed some light on the role of the hippocampus in learning and consolidation of memory. A group of researchers at the Universities of Cambridge and Cardiff examined the physiological processes underlying fear conditioning and memory consolidation in rats (Lee *et al.* 2004). The rats learned to associate a specific environment with an aversive event (an electric shock). After learning that the environment is associated with a shock, the animal exhibits behaviour characterizing fear when placed in that environment. Lee *et al.* found that a type of gene, called *zif268*, was needed for the reconsolidation of context-dependent fear memory, but another factor (called BDNF) was needed for initial consolidation. This shows how different physiological

processes are involved in different aspects of memory formation: one type of factor is needed for immediate consolidation (but not reconsolidation) and another is involved in reconsolidation (but not immediate consolidation).

The retrieval of fear memory also appears to recruit zif268, but in another region of the brain – the anterior cingulate cortex (Frankland *et al.* 2004). Frankland *et al.* found that remote memory for fear was associated with anterior cingulate cortex involvement in mice. Both studies report changes in the brain during fear conditioning. Would similar changes be seen in memory formation and retrieval that was not related to fear? How generalizable are these physiological changes in consolidation and retrieval?

A recent study by Maviel *et al.* (2004) suggests that these specific regions are implicated in non-fear-related memory retrieval. They noted the areas of activation in mice during the acquisition and retrieval of spatial memory. The prefrontal cortex and the anterior cingulate cortex were identified as being critical for the storage and retrieval of spatial memory.

Amnesia

Much of the evidence implicating particular regions of the brain in memory is derived from studies of pathological memory loss, or amnesia. Amnesia refers to the partial or total loss of memory, but two subtypes have been identified that appear to be dissociable: a patient may show symptoms of one while showing none of the other. Retrograde amnesia refers to an inability or difficulty in recalling events prior to the onset of the injury; anterograde amnesia refers to an inability or difficulty in remembering events subsequent to injury. Although patients can talk about events experienced before the onset of their amnesia, they cannot remember what has happened since. The names of people they meet after the injury are hardly ever remembered, even several years after the injury occurred.

The injury giving rise to amnesia can be caused by many factors, including head trauma, surgery involving the lesioning or removal of parts of the cortex or structures found subcortically, cardiovascular disorders (such as stroke), infection, malnutrition, and degeneration of the brain (such as that seen in Alzheimer's disease, which is described in more detail in Chapter 11).

Amnesia is not an all-or-nothing phenomenon. Even people with severe amnesia can recognize familiar faces, learn complex hand-to-eye movements and acquire knowledge of the meaning of words (Squire 1987). The fact that some amnesic patients can remember facts and describe experiences that occurred before the brain injury indicates that their ability to recall explicit memories acquired prior to the injury is not severely disrupted. Of those parts of the brain necessary for establishing new explicit memories, the most important part seems to be the hippocampus. Others are the diencephalon and the frontal lobes.

Diencephalon

The major structures of the diencephalon are the hypothalamus and the thalamus; damage to either causes amnesia. The dorsomedial nucleus of the thalamus and the mammillary body of the hypothalamus appear to be particularly important. The first human case of combined mammillary body and medial thalamic lesions was reported in 1996 (Kapur *et*

al. 1996). These authors found that the patient showed fairly intact retrograde memory but had impaired anterograde memory, especially on a task requiring delayed recall of stories.

Both regions also degenerate to some extent in chronic alcoholics who exhibit Korsakoff's syndrome, which describes the memory impairments seen following long-term alcoholism. They were first described in 1889 by Sergei Korsakoff, a Russian physician, who noted a severe syndrome of memory impairment following chronic alcoholism. The most marked feature of Korsakoff's syndrome is severe anterograde amnesia. The disorder results from a thiamine (vitamin B₁) deficiency caused by alcoholism. Because their diet is primarily made up of alcohol, drinkers get their calories from alcohol and therefore receive fewer vitamins. Alcohol also appears to interfere with the intestinal absorption of thiamine. Prognosis is poor, with only about 20 percent of patients showing much recovery over a year on a B₁-enriched diet.

The location of brain damage in Korsakoff's syndrome is unclear, since all cases are accompanied by damage to many regions. Current thinking suggests specific damage to the medial thalamus and possibly to the mammillary bodies of the hypothalamus. It was believed that severe memory defects resulted from hypothalamic damage, because the mammillary bodies receive hippocampal efferents throughout the fornix. As we have already seen, the role of fornix lesions in amnesia is controversial. However, recent neuroimaging studies have consistently highlighted one dysfunctional feature – hypometabolism – either in the cortex generally or in the thalamus and mesial prefrontal cortex or bilateral medial temporal lobes and mammillary bodies (Paller *et al.* 1997; Aupee *et al.* 2001; Lechevalier *et al.* 2000). Structural studies have found atrophy in the thalamus and mammillary bodies but none in the medial temporal cortex, suggesting that the temporal cortex is spared in Korsakoff's syndrome (Colchester *et al.* 2001).

In a comprehensive study, Reed *et al.* (2003) used PET, MRI and neuropsychological assessment to compare the brain activation and structure and cognitive performance of twelve patients with Korsakoff's psychosis and twelve controls. As previous research had suggested, they found that there was significant atrophy in the Korsakoff patients' thalamus, mammillary bodies and frontal cortex (but not medial temporal cortex). They also found hypometabolism in these patients in subcortical grey matter, especially parts of the diencephalon. Figure 9.2 shows the MRI scan of one such patient.

Figure 9.2

PET scans of patients with Wernicke–Korsakoff's syndrome (from Reed *et al.* 2003)

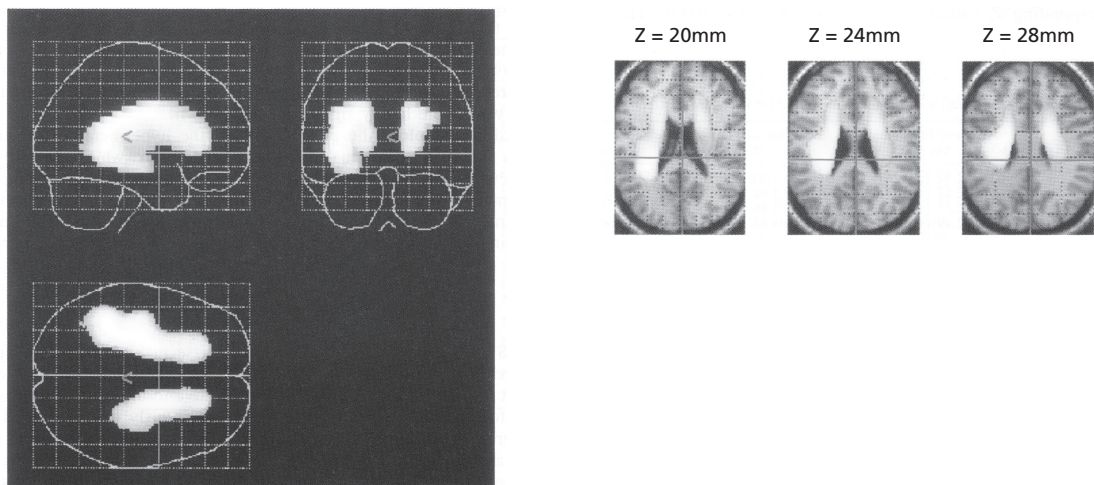

The importance of parts of the thalamus was highlighted by another of memory's famous case studies, NA, described in Chapter 1. Squire and Moore's patient NA had a focal lesion in the dorsomedial nucleus resulting from an accident in which a fencing foil entered the right nostril and punctured the base of the brain (Squire and Moore 1979). Severe amnesia followed. PET scans showed little activation in NA's right medial temporal lobe, which suggests the importance of this structure to memory. However, the relative contribution of other damaged parts of NA's brain to amnesia is unclear.

Impaired recall and preserved recognition: the case of ROB

Aggleton and Shaw (1996) had noted that in some patients with amnesia, there was a dissociation in the types of memory impaired. Those who learned new material were poor at it – recognition and recall were both impaired – but in some cases, recognition was better than recall.

One such case was reported by Hanley and Davies (1997). Their patient, ROB, was a 42-year-old primary school teacher who had suffered an aneurysm in 1990 that led to damage to the caudate nucleus in the left hemisphere. An MRI scan later revealed reduction in the left thalamus relative to the right.

ROB was of above-average intelligence and scored 47/50 on the Warrington Recognition Memory Test (suggesting that her recognition memory was excellent). However, her verbal IQ was 49 points below her non-verbal IQ. A few months after her injury, she returned to work but complained of lack of concentration and difficulty with everyday memory. This made it difficult for her to lead her normal life and was problematic for her work. Her verbal recall was poor (but her visual non-verbal episodic memory recall was good). Again, her WRMT performance for the recognition of words and faces was comparable to controls'. On a different test involving retention of words and non-words, recognition was not significantly impaired. However, free recall was poor. Even when she was taught strategies for recall, these failed.

ROB's case suggests a dissociation between recall and recognition, where the former is impaired and the latter is preserved. Why is this so? One explanation might be that recognition tests are easier to complete or lack the sensitivity to detect mild memory impairment. However, when Hanley and Davies made the tests equally difficult, the recall impairment remained.

Another explanation may involve familiarity. It has been found that recognition memory can be enhanced if the context in which target material is encoded can be reinstated by the target material at retrieval or if the target material seems familiar (Mandler 1980). When ROB was given two versions of the recognition test – one in which the recognition forced a choice (the target is presented with distractors and the participant has to identify the target previously seen) and another in which the target is presented alone and the participant has to say whether they had previously seen it or not – she performed well in both (and failed at a similar level in both). Elderly participants have reported 'knowing' that they had seen words they were asked to recognize rather than 'remembering' them (a pattern reversed in younger participants, even when overall recognition is comparable). This suggests that the elderly sample use familiarity with the target, whereas younger people use context more. If ROB indicates that she knows that a word had been seen previously, rather than remember that it had, she would show evidence that familiarity guided her recognition performance.

When presented with thirty-six words, followed by a delay, followed by the same thirty-six words and distractors, she made no 'remember' responses. This suggests to Hanley and Davies that her impaired recall might reflect a difficulty in recollecting context. However, in a version of the WRMT in which she was asked to rate how pleasant the words were (thus inhibiting deliberate encoding of the words), her recognition performance later involved few 'know' responses. She reported 'remembering' 47/50 words, which is at odds with her previous test performance. Why? It is possible, as the authors note, that ROB was confused about the distinction between remember and know (and this is an easy distinction to misunderstand). It may also be that the first test was a yes/no test, whereas the WRMT was a forced-choice paradigm.

ROB's example is not the only one of poor recall and better recognition memory, Parkin *et al.*'s (1994) patient CB also shows poor recall. They both suggest a dissociation between recognition and recall performance and provide some evidence that these processes are different cognitive operations. However, the reasons for the dichotomy are completely unknown.

Developmental amnesia: the case of AV

In adult amnesia, there is usually a severe impairment in long-term memory, STM is intact, and language, intelligence, perception and social skills are relatively unaffected. The specific deficit can involve the failure to retrieve and/or encode information learned before the incident that led to memory loss (retrograde amnesia) or after (anterograde amnesia). In the anterograde version, declarative or explicit LTM memory is impaired, but implicit ability is preserved; episodic memory appears to be particularly susceptible to disruption. The loss is normally caused by damage to or degeneration of various brain structures but principally the hippocampus, the mesial temporal lobes, the mammillary bodies and the dorso-medial thalamic nuclei in the diencephalons.

Two views of declarative memory are that it is either a single function made up of two types subserved by the hippocampus (Squire *et al.* 1994) or comprises two distinct functions (semantic and episodic memory) that have some features in common (Tulving and Markowitsch 1998). For example, individuals with amnesia cannot recall or recognize experiences in their lives learned before injury but can retain semantic information. The difficulty here is in comparing semantic memory before and after injury: the patient's pre-injury (or premorbid) knowledge has not been systematically tested.

One approach to understanding the underlying neurology of declarative memory would be to study amnesia that developed in childhood. There are some cases of children who have sustained injury to the brain and develop learning impairment, especially episodic and semantic memory problems (Ostergaard 1987; Broman *et al.* 1997). Two studies have suggested that episodic memory may be the more affected of the two. Vargha-Khadem *et al.* (1997), for example, found that three patients who developed amnesia after bilateral hippocampal atrophy were unable to remember everyday events but developed adequate academic and linguistic skills; factual knowledge ranged from low-average to average. Gadian *et al.*'s (2000) study of five 11–16-year-olds reported severe impairment of episodic memory but relative preservation of semantic memory.

A recent case study has provided more evidence for the dissociation between the two types of memory (Brizzolara *et al.* 2003). AV developed amnesia at the age of 6 following acute encephalopathy. At 7 years and 8 months, a scan revealed damage to the right thalamus, both sides of the hippocampus, and the cortical and subcortical areas of the temporal lobe. AV's episodic memory was extremely poor: she could not learn the names of people she had just met, remember homework assignments, locate the psychologist's room or remember the way to the hospital. However, her semantic memory was good: she could learn to read and write, and she acquired a number of facts and procedures after the damage. Figure 9.3 illustrates her performance.

This case study suggests that the pattern of amnesia seen in adults can also be observed in children: both can acquire semantic knowledge despite anterograde amnesia. Both show poor verbal and visuospatial LTM but preserved STM.

Figure 9.3

AV's copy of a figure (bottom left) and reproduction of the figure from memory after a delay of 3 and 15 minutes (right-hand side) (from Brizzolara *et al.* 2003)

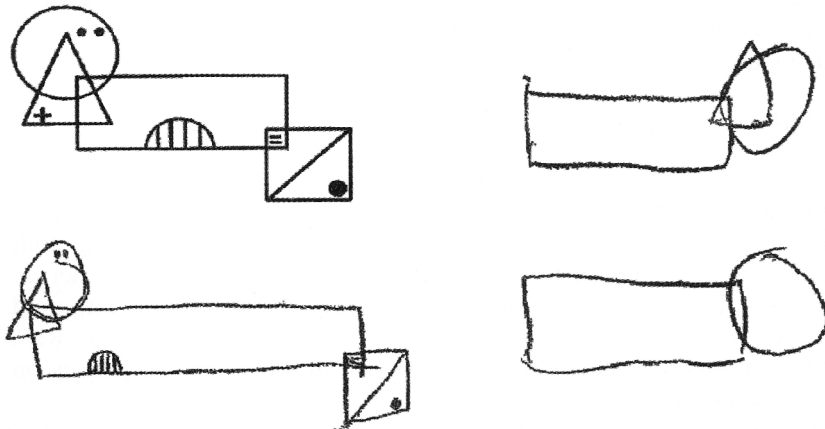

The temporal lobes: the case of HM

The hippocampus, like many structures of the brain, is not fully mature at birth. In fact, it is not until a child is 2–3 years old that most of the structures are fully developed. As a result, many cognitive activities, such as the formation of semantic memories, are not well developed until this age. One reason that few people remember events that occurred during infancy may be the immaturity of the hippocampus. The hippocampus receives information from all association areas of the brain and sends information back to them.

The most famous example of memory impairment following brain damage is patient HM (Scoville and Milner 1957; Milner *et al.* 1968). HM was a young man who had experienced epileptic seizures that did not respond to medication. On 23 August 1953,

when HM was 27 years old, William Scoville surgically removed the medial temporal lobe on both sides of the brain in an attempt to stop the seizures. The surgery involved the removal of the hippocampus and was successful in alleviating the symptoms of epilepsy. However, it did produce symptoms of severe anterograde memory impairment. Following the surgery, HM could carry on a conversation quite adequately, could also talk about his life prior to the surgery but could not talk about anything that had happened since 1953.

Demonstrating a typical anterograde amnesia symptom, HM was unable to store new information in long-term memory, but his short-term memory was good. If he was given a series of numbers to repeat backwards and forwards, for example, he could do this perfectly. It seems as if HM's damage disrupted his ability to form explicit memory rather than disrupting the ability to consolidate memories. HM has been described as having a pure memory deficit, one that affects acquisition or recall of information but leaves other cognitive abilities such as the production and comprehension of language intact.

Recently, however, psychologists have questioned whether HM has a pure memory deficit (MacKay *et al.* 1998). MacKay *et al.* report that when participants described two meanings of ambiguous sentences presented visually (such as 'they talked about the problem with the mathematician'), HM's descriptions were less clear, grammatical and concise and more repetitive than were the control groups'.

The explicit memory impairment associated with HM's amnesia was demonstrated in a classic study by Graf *et al.* (1984). This study appeared to demonstrate that different types of memory were dissociable. They presented a series of six-letter words to a group of amnesic and non-amnesic participants and asked them to indicate how much they liked them. They then presented the participants with two memory tasks. In the first, participants were asked to recall as many words they had seen as they could, a test of explicit memory. In the second task, participants were asked to complete a word using the first three letters. They were not instructed to think about the words they had previously seen (this was a test of implicit memory). Amnesic patients were poorer than controls at remembering words explicitly, but there was no significant difference between the groups on the implicit memory task. This suggested that the locus of the damage in amnesic patients was associated with explicit memory impairment.

Later studies showed that selective damage to parts of the temporal lobe resulted in specific memory impairments. For example, lesions to the anterior temporal lobe and sparing the hippocampus resulted in memory impairments but not of the global kind seen in HM. Lesions to the right temporal lobe produce impairment in non-verbal memory (such as the recall of complex geometric figures, paired-associate learning of nonsense figures and recognition of nonsense figures, tunes and photographs), while left temporal lobe lesions produce impairments in verbal memory (recall of previously presented stories, pairs of words, recognition of words, numbers and nonsense syllables). Verbal memory impairments are common following temporal lobe lesions (Ivnik *et al.* 1987).

Long-term amnesia: the case of JL

Long-term amnesia describes a condition whereby information is normally acquired and retrieved but forgetting is abnormally fast, especially when delays of days or weeks separate encoding and retrieval (Kapur 1993). Delays of 30 s do not impair recall. This contrasts with organic amnesia, where recall and recognition of material can be disrupted by a delay of even a few seconds (Isaac and Mayes 1999).

The abnormal forgetting curve in long-term amnesia suggests that there is some form of impairment in long-term, but possibly not short-term, consolidation of memory. Quick consolidation of episodic and semantic memory appears to rely on the hippocampus and medial temporal lobe, whereas long-term consolidation, a slower process, depends on more widespread neocortical sites, because rehearsal and repetition of material is required (Alvarez and Squire 1994; Nadel and Moscovitch 1997).

JL suffers from epilepsy – at one point suffering twenty to thirty seizures each month – and shows symptoms of long-term amnesia (Mayes *et al.* 2003). JL's brain damage is quite diffuse (see Figure 9.4). Following a closed head injury that led to the epilepsy, there were lesions to the superior, middle and inferior temporal gyrus, the right amygdala and 75 percent of the right medial/lateral orbito-frontal cortex. When tested, JL showed preserved recall and recognition memory 30 minutes after encoding but was significantly impaired at three weeks. JL was especially poor at performing visual recognition tasks such as face recognition and presented with mild retrograde amnesia. Not untypical of patients with amygdala damage, JL could not recognize fear

Figure 9.4

JL's MRI scan (from Mayes *et al.* 2003)

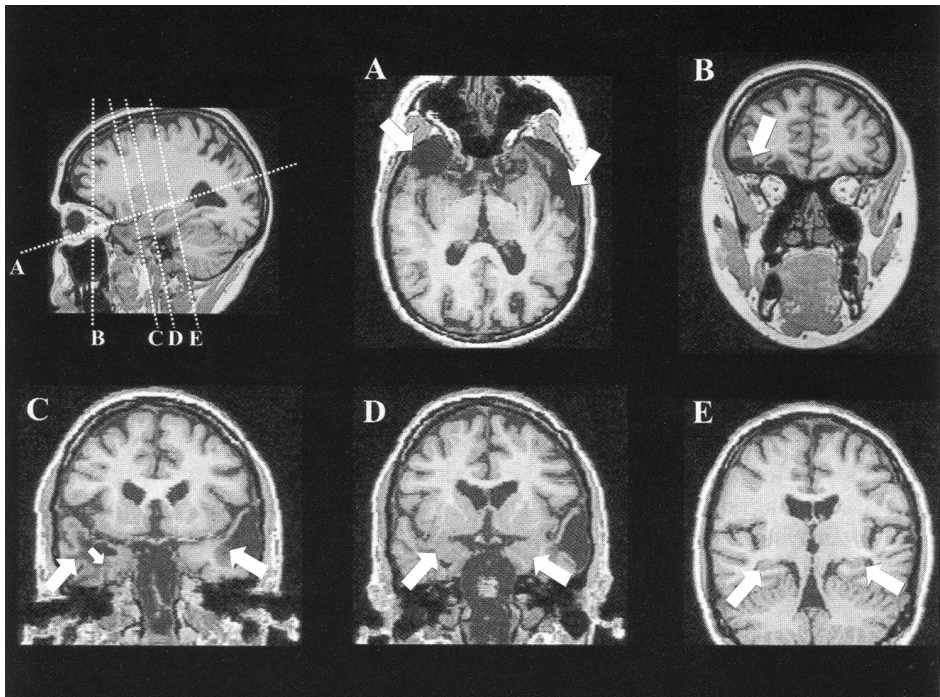

in facial expressions. Curiously, when memories had been rehearsed over long periods, these were relatively well preserved regardless of whether they were encoded pre- or post-morbidity (i.e. before or after the injury).

JL's widespread cortical damage but unimpaired hippocampus supports the hypothesis that disrupted cortical function impairs long-term storage of memories. However, this impairment may apply only when JL does not over-rehearse material, suggesting that the cortex is capable of retention but only when specifically directed to do so.

Encoding and retrieval in episodic and semantic memory

Neuroimaging studies have shown that the encoding of episodic memory, memory for personally meaningful events, people and objects, is associated with activation in regions including the prefrontal and medial-temporal cortex and the cerebellum (Cabeza and Nyberg, 2000). Figures 9.5 (a), (b) and (c) show those areas of the brain found to be activated during episodic memory encoding and retrieval and those involved in semantic memory retrieval.

Studies have usually found left-sided activation during episodic memory encoding, especially during the encoding of verbal material. The encoding of non-verbal material tends to be associated with bilateral activity in the frontal cortex. The role of the left prefrontal cortex in memory may be that of organizing information: this part of the brain is responsible for our ability to group items on the basis of some characteristic or attribute (Gershberg and Shimamura 1995).

To test this hypothesis, Fletcher *et al.* (1998) conducted a PET study in which participants listened to words that were either semantically organized or disorganized but had to be put into categories. As expected, the condition in which the list was already organized produced the least amount of left prefrontal cortex activation, whereas the task requiring the participant to generate an organizational structure resulted in greatest activation. A distractor task reduced activation during the organization task but not during any other encoding task, suggesting that the organizational, executive role of the left prefrontal cortex can be disrupted.

Although retrieval of episodic memory is consistently associated with prefrontal activation (sometimes in both cerebral hemispheres but usually on the right), other regions are also activated depending on the type of material retrieved (Fletcher *et al.* 1996). In an fMRI study, Gilboa *et al.* (2004) found that when healthy participants were shown photographs of their family and asked to generate memories associated with them, the hippocampus was activated, but this activation was attributable to the vividness of the memory associated with the photographs (rather than the age of the photographs). That said, both remote and recent memory retrieval was associated with hippocampal activation but, different regions were activated by the different memories. The retrosplenial cortex was significantly activated by memories for recent events (rather than older ones).

The finding that the prefrontal and medial-temporal lobes show greater activation during the effective encoding of verbal material than ineffective encoding suggests that, in normal readers, these regions may play an important role in the successful learning of verbal material. By extension, therefore, might poor readers recruit the same areas, the same areas more vigorously or different regions?

Figure 9.5

The areas of the brain involved in (a) semantic memory retrieval, (b) episodic memory retrieval and (c) episodic memory encoding, according to recent neuroimaging data (adapted from Cabeza and Nyberg 2000)

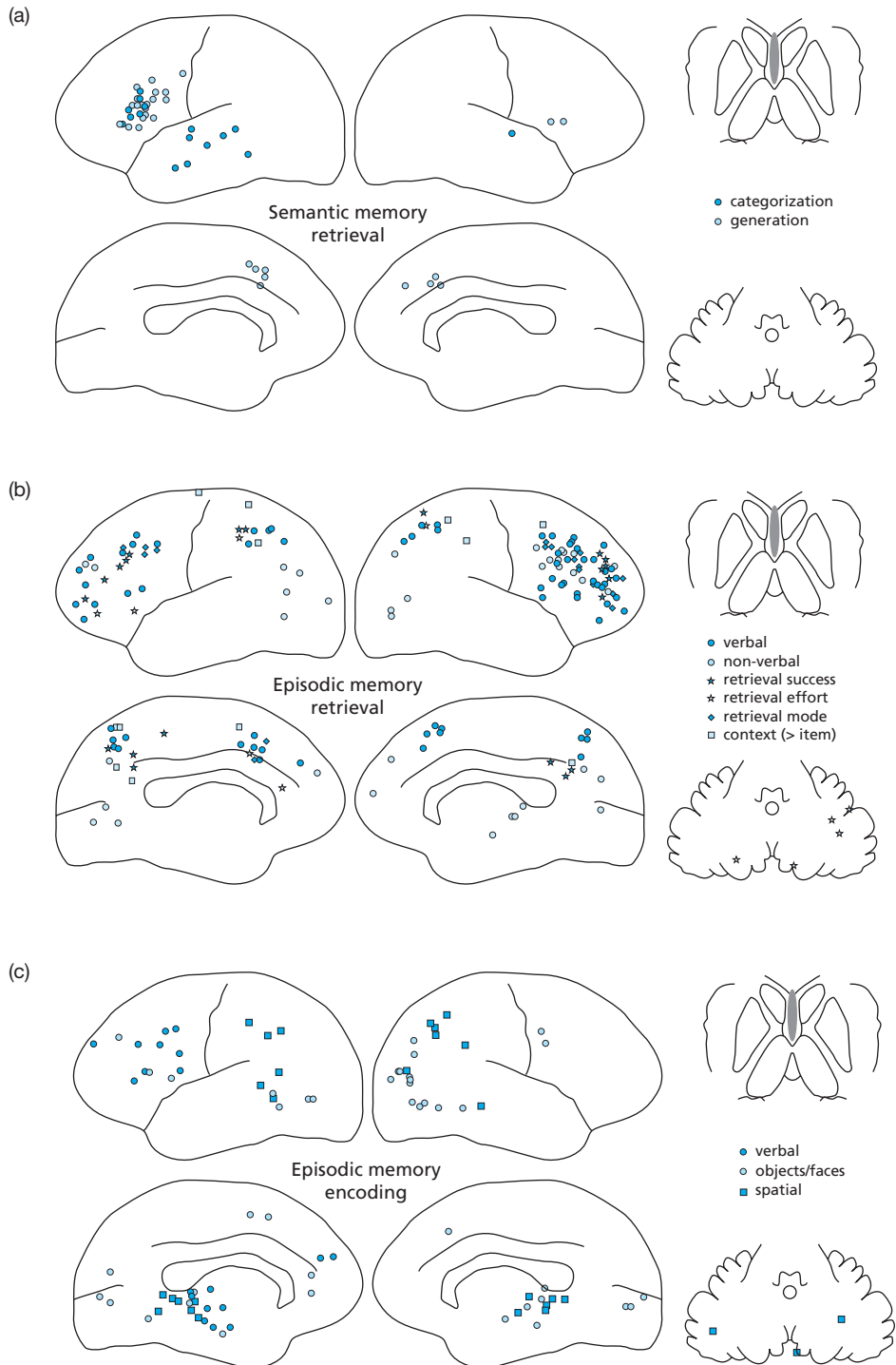

Petersson *et al.* (1999) studied illiterate women with a mean age of 63 who performed a word-association task as their brain activity was monitored using PET. Word pairs were presented to the participants auditorily and the participants were required to learn them. The participants then engaged in a cued recall task. The researchers found that the prefrontal cortex on the left side of the brain was significantly more active during encoding of words that were associated with later successful retrieval. There was also an increase in activation in the medial temporal lobe during effective encoding compared with ineffective encoding. The increases were found for word pairs that were semantically related (*bilhete-comboio*; ticket-train) and phonologically related (*selo-pelo*; stamp-hair). These results confirm the role of the prefrontal and temporal cortex in our ability to successfully encode verbal material.

The man who forgot the last ten years: the case of PO

PO was a 62-year-old civil servant who, in 1984, went to his company doctor complaining of feeling different to normal (Kapur 1997). He had woken up and could not remember what it was he was going to do that day, or how to get to work. He reported being unable to remember what had happened the day before and also revealed that he experienced misty vision while at his desk at work. This lasted around 10 minutes.

A month later, he told the GP he had experienced two to three more episodes. On one occasion, his wife had found him starting his car but being unable to remember what he was doing in it or where he was going. He reported not knowing where he lived, but this confusion cleared up by lunchtime the same day. He reported frequent incidents of blurred vision and slurred speech. He would experience abnormal tastes (such as acetone and fatty sensations), and his memory became increasingly impaired.

In March 1985, he returned to his GP and noted a progressive loss of smell and taste and a loss of memory for events in the previous days. PO's CT scan was normal, but his EEG recording showed abnormal temporal lobe activity. At this point, he could not remember moving house in 1984 or 1991 and could not remember where he had lived for the past twelve years. His wife reported that he frequently could not remember what day it was, or the direction to work; memory for the past eight months was a 'blank'. Everyday memory was good for events occurring minutes previously but poor for events that occurred one to two days previously.

In July 1985, he had an epileptic fit and was diagnosed with temporal lobe epilepsy. Individuals with temporal lobe injury have specific problems with memory retention – autobiographical memory loss has been found in patients with temporal lobe epilepsy (De Renzi and Lucchelli 1993). PO showed clear signs of memory loss, especially retrograde amnesia, and this affected his day-to-day living. He claimed not to be able to remember a film that he had seen on television over Christmas four weeks previously and had recently been repeated. He could remember his secondary schooling and his wedding, but he could not recall the church. He could remember a short honeymoon but could not remember the town where he and his wife had spent it. He could remember being told of his father's death in 1972 and the journey to the funeral but could not remember the funeral itself.

His twenty-fifth wedding anniversary drew a blank, as did any mention of the anniversary party. He remembered being treated in hospital for a bad back but did not

remember the ward or any of the staff. He had no recall of his daughter's or son's wedding, despite being prompted by photographs.

PO's pattern of memory impairment suggests that his autobiographical memory for the ten years prior to the illness was poor, but his memory for the period from the 1940s to 1960s was fairly intact, although even here details were sometimes hazy. For example, although he could remember very little about the houses in which he had lived as an adult, he also recalled very little about the house he grew up in. His IQ was above average, and his score on a memory test battery (the Weschler Memory Scale) was in the average to above-average scale, suggesting that his memory impairment was specific to one domain – episodic memory. Why?

Kapur (1997) suggests three possible explanations:

1. His amnesia reflects the memory disruption caused by the epileptic seizures (in a similar way to that caused by electro-convulsive therapy). PO had experienced a series of small seizures prior to diagnosis – perhaps the cumulative effect of these seizures was this impairment in autobiographical memory.
2. The seizures had disrupted the formation of long-term memory and the consolidation of memories over a period of months.
3. The seizures specifically interfered with the encoding of events as they happened – PO could remember events after a few minutes because the memory trace was strong enough, but recall after a few days was poor because the trace had faded and the information had been abnormally acquired.

Semantic memory refers to our knowledge store of facts – it is memory for what we know (people's names, faces, where they live, and so on). Ways of explaining how semantic memory is organized have been aided by studies of semantic dementia – a condition in which there is impairment of knowledge about the world due to temporal lobe degeneration. One view of semantic processing suggests that there is a modality-specific system so that information about the visual and verbal world is stored differently. An alternative model proposes that meaning is processed by a single system that is modality-free.

To explore the effectiveness of the models in explaining semantic dementia, Snowden *et al.* (2004) studied face and name knowledge in fifteen patients with the disorder. These patients were significantly impaired at the recognition of faces and names when compared with amnesic patients with Alzheimer's disease and a control group. Intriguingly, however, the two 'control' groups were better at recognizing names than faces, whereas the semantic dementia group showed the opposite pattern. When the region of brain degeneration was examined, semantic dementia patients with left atrophy were better at names than faces, whereas patients with right atrophy were better at faces than names.

The authors suggest that these findings support neither model of semantic processing. Instead, they argue, 'the data favour a model of semantic memory comprising a single interconnected network, with dedicated brain regions representing modality specific information'. The anterior temporal lobes would maintain the role of binding together the information needed for verbal and visual semantic processing.

Working memory

The ability to manipulate information in memory over a short space of time seems to be the primary responsibility of the frontal lobes, as you saw in Chapter 5 (Fletcher and Henson 2001). These regions also become active during the retrieval of material that has been retained over long periods, suggesting that the frontal lobes may play a general rather than specific role in encoding and retrieval. Fletcher and Henson (*ibid.*) distinguish between two types of measure in working memory tasks: maintenance and manipulation. Working memory maintenance tasks involve measuring the process of keeping information in mind; working memory manipulation tasks involve measuring the reorganization of material that is kept in mind.

A typical maintenance task involves presenting a participant with three to nine stimuli and then asking him or her to indicate whether a single stimulus presented subsequently formed part of the original stimulus array. The letter-based version of this task is usually associated with significant increases in activation in the left hemisphere, especially the ventrolateral frontal cortex, parietal lobe and premotor area (Awh *et al.* 1996). When the task involves spatial or object information, right hemisphere activity is usually seen. Often, the same regions activated by letters or words in the left hemisphere are also activated in the right by spatial/object stimuli (Smith *et al.* 1996).

A manipulation task in working memory might involve presenting the participant with a series of five letters and then asking them to recite the letters forwards, backwards or in alphabetical order, in mind. After a delay, the participant is asked to match the number order of a given letter according to the mental manipulation (e.g. forwards, backwards or alphabetical). For example, the following letters might be presented:

B, M, T, E, I

and the participant's task would be to alphabetize them. This would then be followed by the presentation of a 'digit probe' – for example, 4 – indicating that the participant should recall the fourth letter in the alphabetized list. The number 4 should elicit the correct answer M (because M is the fourth letter in the alphabetized string, B, E, I, M, T). During the delay, activation is usually seen in the ventro-lateral and dorso-lateral frontal cortex;

Figure 9.6

The areas of the brain involved in working memory, according to recent neuroimaging data (adapted from Cabeza and Nyberg 2000)

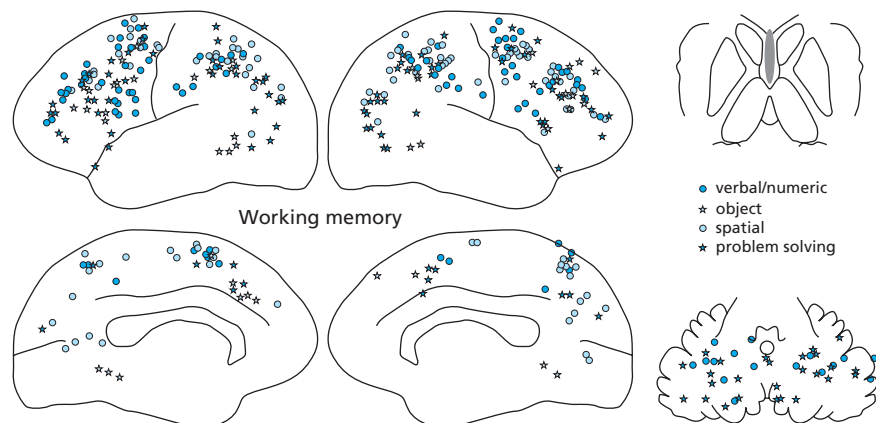

during the re-ordering part of the task, activation is seen more in the dorso-lateral part (D'Esposito *et al.* 1999). Figure 9.6 summarizes the neurogeography of working memory, based on Cabeza and Nyberg's (2000) meta-analysis of PET and fMRI studies.

The specific impairment of phonological STM: the cases of PV and JB

Two case studies in the neuropsychology of memory have, perhaps more than any others, shown how single-case studies can be used to test models of memory. PV and JB, studied by Basso *et al.* (1982) and Vallar and Baddeley (1984), and Shallice and Butterworth (1977) and Warrington *et al.* (1971), respectively, were two patients who showed that phonological short-term memory could be selectively impaired. Both patients' language was intact.

The contribution of each has been well summarized by Nadine Martin (2002). PV showed a profound impairment in auditory STM but had intact language and preserved LTM. At the age of 28, she had suffered a stroke that left her initially with mild aphasia and poor sentence repetition. Her aphasia dissipated (the other deficits remained), and although her speech production and comprehension were preserved, she showed a severe deficit in the ability to remember series of spoken or written words. For example, her memory span for digits was two; for letters it was one. Span for concrete words was slightly higher, and sentence repetition span was six words. However, her visual span was significantly better than her auditory span. When the stimuli were presented auditorily and a delay occurred before she had to recall them, her span plummeted. When the stimuli were written down, the delay did not impair her recall as significantly.

PV's specific impairment allowed the testing of an important model of working memory (Baddeley and Hitch 1974; Salame and Baddeley 1982). The model proposes a phonological short-term store for auditory memory that holds auditory input, an 'articulatory' or 'phonological loop' that uses subvocal articulation to refresh the contents of the phonological store, and a central executive that overviews and controls these processes. The model suggests that the dissociation often observed between STM and LTM can be explained by a deficit in the STM component of the model – the phonological store and the articulatory loop. The working memory model is illustrated in Figure 9.7.

To test this, Vallar and Baddeley (1984) and Vallar and Papagno (1986) investigated the phonological similarity effect in PV. This effect is simply a shorter span for the memory of phonologically similar letters than for dissimilar ones. They also explored the word length effect – that memory span is longer for shorter words than for longer ones (because of the limitations of the phonological loop). Finally, articulatory suppression was tested by asking the patient to recall words while listening to repeated, irrelevant speech.

They found that the phonological similarity effect was found for auditorily presented letters but not for visually presented ones. Articulatory suppression did not affect recall, suggesting that PV did not use subvocal rehearsal. If this is so, the word length effect should not be present during the auditory-verbal span task. Word length did not affect the number of letters recalled. She did perform slightly better when strings of five-syllable words rather than two-syllable words were presented (span was two–three items), possibly because these stimuli contained meaning and were therefore semantically encoded.

Figure 9.7

(a) A model of working memory; (b) the proposed brain pathways involved in phonological working memory

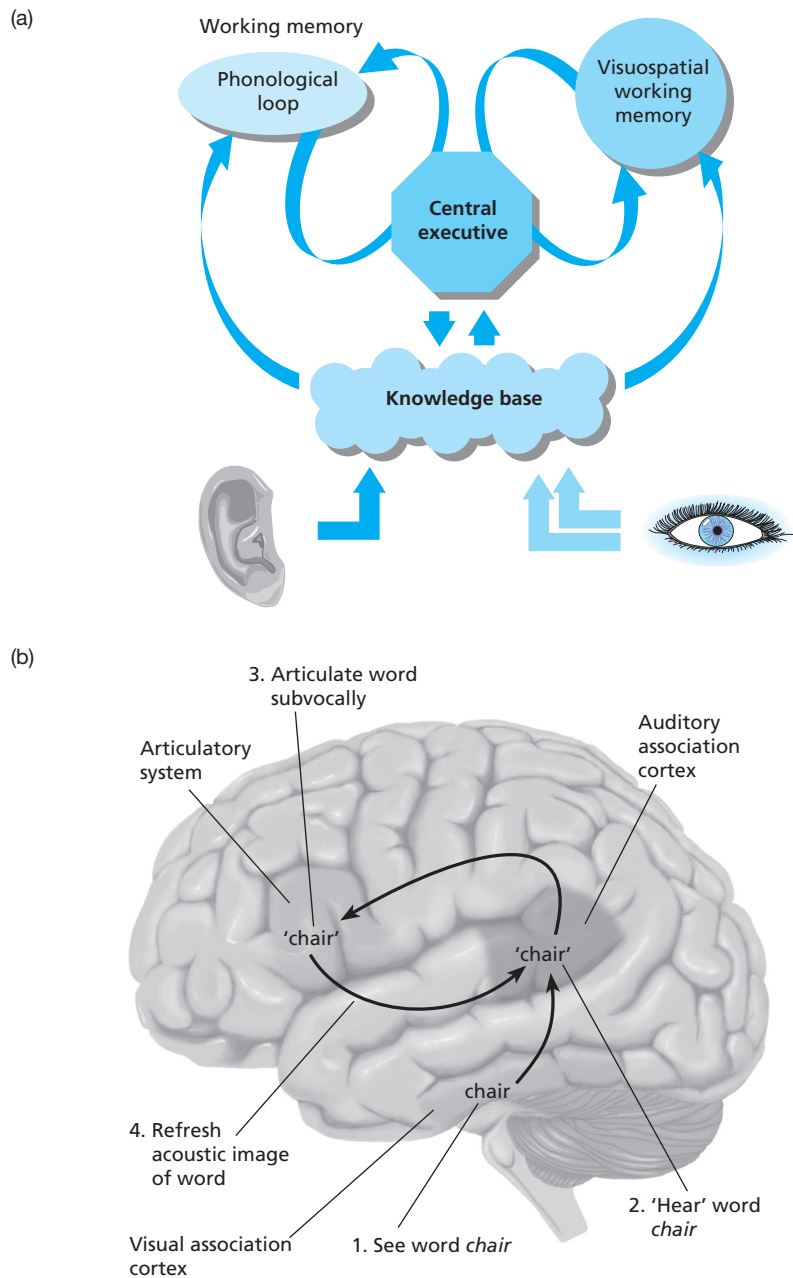

Vallar and Papagno (1986) also used PV's deficit to test two models of recency – the notion that we recall more items from the end of an auditorily presented list than its middle or beginning. PV's recall showed a decreased recency effect when the list was auditory (more so than when the list was visual). These data were used to support an

account of STM that argues that the recency effect in free recall of auditorily presented word lists reflects the output of the phonological store. The deficit might explain why PV's sentence repetition was poor: when listening to sentences, we have to hold words in memory while we get to the end, at which point we can make overall sense of what is said to us. If the phonological STM store in PV was disrupted, this would be difficult.

A similar deficit is seen in patient JB. Following the removal of the left angular gyrus due to a meningioma, JB showed restricted auditory–verbal STM when tested twelve years after the surgery. Speech was normal and fluent, and naming was good. There were mild complex sentence comprehension problems but, like PV, memory span was better for visual than for auditory stimuli. If there was a delay of even 5 s between presentation and recall of auditory letters on the span task, JB would perform poorly. This poor performance was absent when the delay occurred during the visual version of the task.

The neurochemical basis of working memory

Neurons projecting to the prefrontal cortex contain a specific neurotransmitter, acetylcholine, which is delivered by a specific type of neurotransmitter pathway, the cholinergic pathway. Recently, it has been hypothesized that an increase in acetylcholine to the frontal cortex might lead to an improvement in working memory (Furey *et al.* 2000). Furey *et al.* administered the drug physostigmine (which increases the amount of acetylcholine available) to a small group of men and women who completed a working memory task as an fMRI scanner monitored their brain activity. Participants completed the same task the following day but received a placebo (saline). The task involved watching a human face for three seconds and then after a nine-second delay when the face was removed identifying which of two or more subsequently presented faces was originally seen.

Participants who received the physostigmine showed increased activation in the visual cortex during the encoding of the face, activation that was significantly lower in the saline condition. The physostigmine condition also produced better face recognition when participants had to decide which of the faces had been previously presented. The finding suggests that the improvement in working memory may be due to enhanced visual processing in the earliest stages of encoding. One practical application of this may be to administer such drugs to patients with stark memory deficits, such as patients with Alzheimer's disease (Robbins *et al.* 2000).

Spatial navigation and memory

The hippocampus appears to be important for navigating or exploring the spatial environment and in forming representations of the locations of objects (O'Keefe and Nadel 1978). This was clearly seen in a very famous experiment by Morris *et al.* (1982). The experimenters placed rats in a pool of milky water that contained a platform just beneath

the water. In order to avoid swimming constantly, the rats had to find the platform hidden beneath the milky water and stay there.

Eventually, through trial and error, the rats would find the platform. Then the researchers performed a series of experimental ablations. One group of rats received lesions to the hippocampus, another received lesions to the cerebral cortex and another received no lesion. The rats were then allowed into the pool. Rats with the hippocampal lesions showed extremely poor navigation compared with the cortex lesion and control group: they were unable to find the platform. When rats had learned that there was a platform underwater and were then allowed to explore the water with the platform removed, those with an intact hippocampus would spend longer in the part of the maze where the platform had been positioned previously. However, the rats with hippocampal lesions did not engage in this 'dwell time' in the quadrant where the platform once had been (Gerlai 2001). This suggested an important role for the hippocampus in spatial learning.

The hippocampus is also implicated in a different type of learning – context-dependent fear conditioning (*ibid.*). Damage to the hippocampus in rats causes the animals to forget the place in which they received an electric shock, but if they are presented with a stimulus, a tone, that was paired with the pain during the initial conditioning, they still respond in the same way as they did during conditioning: the tone alone would lead to a fear response (Phillips and LeDoux 1994). These findings suggest that the hippocampus is important to the learning of a sense of place, findings that have been confirmed by human studies.

Both rodents and primates show deficits in what has been called spatial memory (Redish and Touretzky 1997). Spatial memory, the ability to encode and retrieve information about locations and routes, is, like memory itself, not a unitary function. Kessels *et al.* (2001), for example, note that there is a difference between memory for routes and paths and the knowledge of spatial layouts that enables a person to find an object or a location.

The role of the hippocampus in aspects of spatial memory have been well documented in animals, but O'Keefe and Nadel's view of hippocampal function has not gone unchallenged. Olton *et al.* (1979), for example, argued that the hippocampus was not exclusively responsible for spatial memory but was more involved in working memory. According to the theory, tasks used in spatial memory tasks were tests of short-term or working memory rather than spatial memory: all required the organism to keep information in mind while they engaged in other behaviour that used such information, and this is the feature that was disrupted by damage.

To test whether the hippocampus played more of a role in working memory or spatial memory, Kessels *et al.* conducted a meta-analysis of twenty-seven studies that reviewed the consequences of hippocampal dysfunction. The researchers examined the effects of damage on the ability of a person to (1) learn to navigate their way through a maze, a task that requires spatial and temporal ordering; (2) hold information about spatial layouts in mind for a short space of time, a measure of spatial working memory; (3) remember positions of objects and locations; and (4) bind or integrate information about an object and its location.

There was impairment on all tasks, but some tasks were performed worse than others. Whereas mild or moderate impairments were found on tasks requiring integration of information or navigation around a maze, there was little effect of hippocampal damage on spatial working memory. However, there was a large impairment on tests of positional memory, such as locating Xs in an array of letters. The lesions in patients showing mild to severe impairment were invariably to the right hippocampus, a finding that is consistent with O'Keefe and Nadel's hypothesis that the right hippocampus is specialized for mapping spatial information.

There may also be evidence of hippocampal involvement in spatial navigation in healthy individuals. Maguire and her colleagues set up a novel and unusual experiment to see whether the hippocampus was active during spatial navigation (Maguire *et al.* 1997). In their study, eleven London taxi drivers with fourteen years experience of driving described the shortest legal route between two locations in London as a ET scanner observed their brain activity.

The taxi drivers were also asked to recall famous London landmarks (an examination of topographical memory). The activation during these tasks was compared with that during the recall of sequences from famous films. When the drivers described the route from one location to another, significant activation of the right hippocampus was found (but was not found with the landmark or film conditions).

This finding suggests that the right part of the hippocampus is involved in the retrieval of information that involves recall of movement in complex environments (see Plate 9.1). In another PET experiment, participants were asked to navigate their way around a familiar but complex virtual town, using a pair of virtual reality goggles (Maguire *et al.* 1998). Activation of the right hippocampus was again associated with knowing accurately where places were located and with navigating between them. The speed with which individuals navigated around their environment was associated with right caudate nucleus activity. However, also activated were the right inferior parietal and bilateral medial cortex, which suggests, as many imaging studies do, that memory performance is not exclusively dependent on one region or structure.

However, Rosenbaum *et al.* (2005) have challenged the view that the hippocampus is implicated in the encoding and retrieval of long-term spatial or topographical information (such as knowing the route to a childhood home). They note that Maguire *et al.*'s data show that activation was actually observed in the parahippocampal gyrus, not the hippocampus. They also note that their own fMRI study reported that participants who were engaged in the recall of well-rehearsed knowledge about a city's topography showed greatest activation in the parahippocampal gyrus (there was slight activation in the hippocampus) (Rosenbaum *et al.* 2004). This study, together with those of amnesics who can recall the topography of the neighbourhood in which they grew up (e.g. Teng and Squire 1999), provides a challenge to the view that the hippocampus is needed for the acquisition and retrieval of long-term topographical memories. A case study reported by Rosenbaum *et al.* (2005) provides another source of evidence. They studied SB, a patient with probable Alzheimer's disease who had been a taxi driver in Toronto for forty years. His remote memory for spatial locations in Toronto was compared with that of two other retired taxi drivers (with different illnesses) and a healthy control group. His ability to navigate spatially between various Toronto landmarks was comparable with that of the other participants. His most pronounced deficit was an inability to distinguish between Toronto landmarks and unknown buildings (an impairment that extended to famous world landmarks). While the hippocampus may be necessary for the acquisition and retrieval of spatial information in the short term, these results suggest that its role in long-term memory for old environments is much less certain.

Are memory processes lateralized?

A model called the HERA model has been proposed to account for the differences in activation seen during memory encoding and retrieval. HERA stands for hemispheric encoding-retrieval asymmetry, and the model argues that greater left than right frontal

cortex activation is seen during episodic encoding, whereas greater right than left frontal cortex activation is seen during episodic retrieval (Tulving *et al.* 1994). The evidence reviewed in this chapter and more extensively in Fletcher and Henson (2001) and Cabeza and Nyberg (2000) suggests very strong support for the model. In general, verbal encoding is associated with left frontal activation, whereas right activation is more common during retrieval; but, as we have seen, such areas as well as others can be bilaterally active during encoding and retrieval. Why?

Fletcher and Henson put forward some interesting possibilities. Two are statistical and methodological and hinge on (1) the type of statistical parameters a study sets for statistical significance in neuroimaging research (different studies may set different parameters) and (2) the small number of samples used in neuroimaging research. A further reason may be the lack of clarity over the precise definition of cognitive processes in memory studies. Setting aside questions regarding what is verbal and what is non-verbal (and whether these two categories could be considered unitary), there are also questions regarding the nature of encoding and retrieval. Not all studies use the same measures of encoding or retrieval; perhaps the inconsistencies in findings can therefore be attributed to these different methodological approaches.

Summary

Memory is a process that involves the encoding and retrieval of information. Various subtypes have been suggested – implicit versus explicit and declarative versus procedural, for example. Some of the most widely studied subtypes are working memory (the ability to hold information in mind for a short time while engaged in another task), episodic or autobiographical memory, and semantic memory (memory for knowledge, such as knowing the capital cities of the world). Because memory is a process and not a unitary entity, ‘memory’ does not reside in a specific area of the brain. However, parts of the process are associated with activation in regions of the healthy brain and are disrupted by damage to others. Of the subcortical structures, the hippocampus and the mammillary bodies and fornix are important. The hippocampus is involved in the consolidation of memory, and damage to it causes an impairment in the shift from short- to long-term memory. It may also play an important role in spatial navigation. The mammillary bodies and fornix are degenerated in alcoholic dementia. Encoding and retrieval of episodic and semantic memory has been associated with activation in the prefrontal and medial temporal cortex. Activation may be left-sided if the episodic material is verbal, bilateral if non-verbal. Working memory selectively activates the prefrontal cortex.

Recommended further reading

Amnesia and memory disorders

Baddeley, A.D., Kopelman, M. and Wilson, B.A. (2002). *Handbook of Memory Disorders*. Chichester, UK: John Wiley & Sons.

Kopelman, M.D. (2002). Disorders of memory. *Brain*, 125, 2152–90.

Mayes, A.R., Isaac, C.L., Holdstock, J.S., Cariga, P., Gummer, A. and Roberts, N. (2003). Long-term amnesia: a review and detailed illustrative case study. *Cortex*, 39, 4/5, 567–603.

Parkin, A.J. (1997). *Case Studies in the Neuropsychology of Memory*. Hove, UK: Psychology Press.

- Reed, L.J., Lasserson, D., Marsden, P., Stanhope, N., Stevens, T., Bello, F., Kingsley, D., Colchester, A. and Kopelman, M.D. (2003). FDG-PET findings in the Wernicke-Korsakoff. *Cortex*, 39, 4/5, 1027–45.
- Ward, J. (2003). Encoding and the frontal lobes: a dissociation between retrograde and anterograde amnesia. *Cortex*, 39, 4/5, 791–812.

Neuropsychology of normal memory

- Abel, T. and Lattal, K.M. (2001). Molecular mechanisms of memory acquisition, consolidation and retrieval. *Current Opinion in Neurobiology*, 11, 180–7.
- Conway, M.A., Pleydell-Pearce, C.W., Whitecross, S. and Sharpe, H. (2002). Brain imaging autobiographical memory. *The Psychology of Learning and Motivation*, vol. 41, 229–63.
- Eichenbaum, H. and Cohen, N.J. (2004). *From Conditioning to Conscious Recollection*. Oxford: Oxford University Press.
- Eskes, G.A., Szostak, C. and Stuss, D.T. (2003). Role of the frontal lobes in implicit and explicit retrieval tasks. *Cortex*, 39, 4/5, 847–69.
- Fletcher, P.C. and Henson, R.N.A. (2001). Frontal lobes and human memory. *Brain*, 124, 849–81.
- Fletcher, P.C., Stephenson, C.M.E., Carpenter, T.A., Donovan, T. and Bullmore, E.T. (2003). Regional brain activations predicting subsequent memory success; an event-related fMRI study of the influence of encoding tasks. *Cortex*, 39, 4/5, 1009–26.
- Gabrieli, J.D.E. (1998). Cognitive neuroscience of human memory. *Annual Review of Psychology*, 49, 87–115.
- Greenberg, D.L. and Rubin, D.C. (2003). The neuropsychology of autobiographical memory. *Cortex*, 39, 4/5, 687–728.
- Logie, R.H. (2003). Spatial and visual working memory: a mental workspace. *The Psychology of Learning and Motivation*, vol. 42, 37–78.
- Postle, B.R., Druzgal, T.J. and D'Esposito, M. (2003). Seeking the neural substrates of visual working memory storage. *Cortex*, 39, 4/5, 927–46.
- Special issue of *Neuropsychology* on 'Long-term spatial memory', 2004, 18, 3.
- Squire, L.R. and Schacter, D.L. (2003). *Neuropsychology of Memory*. Hove, UK: Psychology Press.
- Squire, L.R., Stark, C.F.L. and Clark, R.E. (2004). The medial temporal lobe. *Annual Review of Neuroscience*, 27, 279–306.
- Wagner, A.D., Kovstaal, W. and Schacter, D.L. (1999). When encoding yields remembering: insights from event-related neuroimaging. *Philosophical Transactions of the Royal Society of London*, B, 354, 1307–24.
- Wixted, J.T. (2004). The psychology and neuroscience of forgetting. *Annual Review of Psychology*, 55, 235–69.

10

Emotion – normal aspects

What is an emotion?

Subcortical structures and emotion

Hippocampal system

The amygdala and the conditioning of fear

The amygdala and fear in humans

Frontal lobes: happiness, sadness and inappropriate behaviour

Hemispheric asymmetry and the recognition and expression of emotion

Emotional perception

Emotional experience

Emotional experience: anger and disgust

Hemispheric lateralization and emotion: neuroimaging data

Models of human emotional expression: neuropsychological perspectives

Summary

Recommended further reading

What is an emotion?

Neuropsychology has long had an active if ululating interest in the biology and psychology of emotion. However, one rather fundamental problem encountered early on in evaluating any physiological basis of human emotion, is achieving a satisfactory definition and characterization of emotion. In short, what exactly is an emotion? One study has listed 223 terms representing emotion (Conte 1975), while another found that 556 descriptive words and phrases were generated by students asked to name emotion-related words (Davitz 1970). Similarly, Kleinginna and Kleinginna (1981; cited in Plutchik 1994), in a review of dictionaries, textbooks and other materials, identified ninety-two different definitions of emotion. In view of all this heterogeneity and ambiguity, it is not surprising that emotion has ‘proved to be a slippery concept for both psychologists and neuroscientists’ (LeDoux 1995a).

Scientists have made several attempts to define emotion. Its literal Latin translation is ‘to move’ or ‘to stir up’. One of the earliest modern definitions was proposed by William James (1884). James had argued that emotion was our feeling of bodily changes when ‘the bodily changes follow directly the perception of the exciting fact’. A century later, Stuss and Benson (1983) noted that emotion is ‘a broader term that brings together a sizeable number of behavioural responses linking bodily and mental activities with the underlying feeling tone’. Other definitions have included ‘reactions to an appropriately evocative stimulus involving cognitive appraisal/perception, subjectively experienced feeling, autonomic and neural arousal, expressive behaviour, and goal-directed activity’ (Borod 1992) or as a term ‘referring to a group of interrelated brain functions – emotional

expression and emotional experience' (LeDoux 1987). Others have regarded emotion in more behaviouristic terms. Watson (1924), for example, saw emotion as 'an hereditary "pattern-reaction" involving profound changes of the bodily mechanisms as a whole, but particularly of the visceral and glandular systems', whereas Rolls (1990) suggests that 'emotions can be usefully defined as states produced by instrumental reinforcing stimuli'. Instrumental reinforcers are defined as 'stimuli which if their occurrence, termination or omission is made contingent upon the making of a response, alter the probability of the future emission of that response'. As you saw in Chapter 5 on frontal lobe function, Rolls has suggested that emotions are mediated by connections between the orbito-frontal cortex and other subcortical structures. Our experience of emotion is the result of the activation of these connections by reward and punishment. Not surprisingly, this behaviourist view of emotion is derived largely from animal studies, in which fear and anxiety (as well as immediate and delayed reward) can be carefully manipulated.

However, one distinction that is almost unanimously accepted in the literature is that emotion is different from 'mood' and 'affect'. Affect, as Brewin (1988) notes, is a broad term and subsumes much behaviour, including mood, feeling, attitude, preferences and evaluations. It has been described as the expression of emotion (Stuss *et al.* 1992). Mood sometimes refers to the frame of mind or 'emotional state' of a person, which is defined by the individual's internal state and not external behaviour. Emotions are thought to be briefer, more spontaneous and detectable from the appearance of the organism.

The notion of frame of mind is important given that the most frequently debated issue in the psychology of emotion is the question of whether cognition is a necessary precursor of emotion or whether emotions may occur without any cognitive precursor. This issue in essence revolves around the definition of cognition (LeDoux 1995b). If sensory and perceptual input constitute cognitive processes (such as appraisal), then emotion clearly has cognitive determinants. Put very crudely, a person at the edge of a cliff, blindfolded and unaware that he is at the edge of a cliff will not experience as much anxiety as an individual who has had the blindfold removed. The sight of the drop and the rocks below (visual input), combined with the sight and sound of the sea (visual and auditory input), act as sensory cognitive cues. They are the stimuli that the individual associates with fear. Thus, arguably, an emotion cannot occur without perception and the appraisal of the perceptual world.

Lazarus (1966), for example, has suggested that emotions arise from 'how a person construes the outcome, actual or anticipated, of a transaction or a bit of commerce with the environment', i.e. a certain amount of appraisal must take place before the individual can experience what is thought to be an 'emotion'. This views appraisal as information processing. Weiner (1985) has similarly argued that human emotion depends on cognitive operations such as attributions and appraisals. Both of these approaches argue that cognition is a necessary precursor of emotional experience and expression.

The alternative view, that cognition is unnecessary for emotion, has been most famously argued by Zajonc (1980). He suggested that affect is more than a post-cognitive emission and that cognition is not a necessary precursor of emotional response. Ekman (1984), in a form of halfway house, suggests that affect and cognition involve separate biological systems that interact in a Cartesian way. However, as LeDoux has suggested, if perception is the same as cognition, then all emotion is preceded by cognition.

Given that the definition of an emotion, in psychological terms, is complicated, it might be more beneficial to describe what an emotion should be and make prescriptive judgements. For example, we may not be able to define emotions, but we know that happiness and sadness are two of them. According to Ekman (1973), for example, there are six 'basic' emotional reactions, and other emotions are made up of these. These emotions

are happiness, anger, fear, sadness, disgust and surprise. While the first five appear plausible, the last may be itself surprising: it was included in Ekman's list based on the assumption that the facial expression associated with this emotion should be recognized cross-culturally.

There have been objections to this list of basic emotions and of the use of the term 'basic' (Russell 1994). Ortony and Turner (1990), for example, have argued that we 'cannot find basic emotions' since 'we do not have and probably cannot have, a satisfactory criterion of basicness.' Thus there is conflicting opinion not only regarding the definition of emotion but also of what constitutes a basic emotional response, a point worth bearing in mind when considering the findings from emotion studies.

One way out of this quagmire of contradictions, objections and ambiguities might be to outline particular neural features of emotions that might distinguish one from the other. If happiness is an emotion, then it must recruit neural systems that distinguish it from sadness or fear or anxiety. In fact, there is evidence from animal and human studies not only that certain neural pathways are implicated in the expression of particular emotions but also that particular brain structures and regions are also selectively involved. In animal studies, much work has revolved around the amygdala and thalamus. In humans, the cortex (especially the orbito-frontal cortex) has been suggested as regions important for the expression and recognition of emotion, with subcortical structures heavily involved in specific emotions.

Subcortical structures and emotion

The brain has evolved from the brainstem into a complicated mass of circuitry. The most basic structures of the brainstem regulate the autonomic and endocrine systems, two systems that are important to emotion. The development of the limbic system, the later differentiation of the paralimbic region arising from regions around the limbic system, and the extension of the paralimbic region to neocortical areas, afforded the brain greater flexibility in the expression and interpretation of emotions.

Descending connections are made from the neocortex to the subcortex ('top-down' connections); ascending connections from lower brain regions to the neocortex are also found, such as the regulatory projections from the brainstem and limbic system to the cortex, and the pathways conveying information from the musculature and viscera ('bottom-up' connections). As this organization might suggest, emotion cannot be localized exclusively to a specific area of the brain, but specific areas of the brain may be involved in the recognition or experience of an emotion. The principal subcortical structures thought to be involved in the regulation of emotion are the brainstem, the hippocampal system and the amygdala.

Hippocampal system

The hippocampal system includes the entorhinal cortex on the input side and the subiculum and lateral septum on the output side. Perhaps the most famous model of hippocampal function as related to emotion is that proposed by Gray (1982; Gray and McNaughton 2000). In this model, a neuropsychological model of anxiety, the 'septohippocampal system' is thought to respond to innate fear signals, signals that predict

punishment and those that predict non-reward. Once a stimulus has been detected, the hippocampus inhibits motor behaviour, adjusts autonomic responses, arouses the cortex and allows the organism to focus on the relevant parts of the environment. Those individuals with highly reactive systems will be sensitive to aversive signals and exhibit a more introvert personality and be more prone to anxiety and depression. Gray's model is revisited in the section on abnormal emotion in Chapter 12.

There is also evidence that the hippocampus plays a role in trace conditioning – this behaviour arises when an interval occurs between the termination of the conditioned stimulus and the onset of the unconditioned stimulus. In an fMRI study, Knight *et al.* (2004) reported that hippocampal activation was greater when people correctly predicted the onset of the unconditioned visual stimulus (other areas were also activated during the trace conditioning, including the supplementary motor areas, the frontal operculum, the middle frontal gyri and the inferior parietal lobe). The finding suggests that the hippocampus may code temporal information during trace conditioning, but other regions – associated with working memory function – maintain the mental association between the conditioned and the unconditioned stimulus. Evidence for the latter comes from a study of OFC pathway inhibition in rats (Runyan *et al.* 2004). This reported that the inhibition did not interfere with the encoding of memory during trace conditioning but did impair memory retention. In a Pavlovian conditioning paradigm in which a previously neutral stimulus (light) was associated with a painful one (electric shock), Knight *et al.* (1999) also observed increased activation in the anterior cingulate cortex just anterior to the pre-frontal cortex as training and learning progressed. When the light and shock were not paired (i.e. they were not associated) this activation did not occur.

The amygdala and the conditioning of fear

Described by Aggleton and Mishkin (1986) as the sensory gateway to the emotions, the amygdala is a collection of subnuclei in the anterior temporal lobe thought to be heavily involved in the learning and maintenance of fear, anxiety and other emotions (Aggleton 1992). The amygdala, together with the hippocampus, septum, fornix and olfactory bulb, is considered part of the limbic system, a collective name for subcortical structures near the thalamus. It was thought that emotional expression was the result of the activity of these interconnecting structures, the so-called Papez circuit (Papez 1937) illustrated in Figure 10.1.

If the anterior temporal lobes are damaged or removed in monkeys (which means that the amygdala is removed or damaged too), inappropriate emotional behaviour is elicited. For example, they might indiscriminately consume anything that is edible, become highly sexually active, mount sexually inappropriate objects, repeatedly explore familiar objects and exhibit tameness and lack of fear. This has been termed the Kluver–Bucy syndrome (Kluver and Bucy 1939). In humans, however, the same behaviour is not elicited.

According to Halgren (1992), the amygdala 'has all of the right connections with the cognitive neocortex and visceral brainstem to provide the link between them that is central to emotion'. It has connections with the neocortex, hypothalamus, septum, thalamus, hippocampus and reticular formation. Inputs from the sensory systems normally arrive in the amygdala. The amygdala and hippocampal system also project to regions controlling endocrine, autonomic and motor activity. In his review of the neural basis of emotion, LeDoux (1995b) describes some of the pathways to and from various brain structures, but especially the amygdala and thalamus, that are involved in the conditioning of fear. Fear is a 'good' emotion to study in a laboratory, since procedures for

Figure 10.1

The Papez circuit (from Kandel, E.R. *et al.*, *Essentials of Neural Science and Behaviour*, © 1995, McGraw-Hill/Appleton & Large, reproduced with permission of The McGraw-Hill Companies)

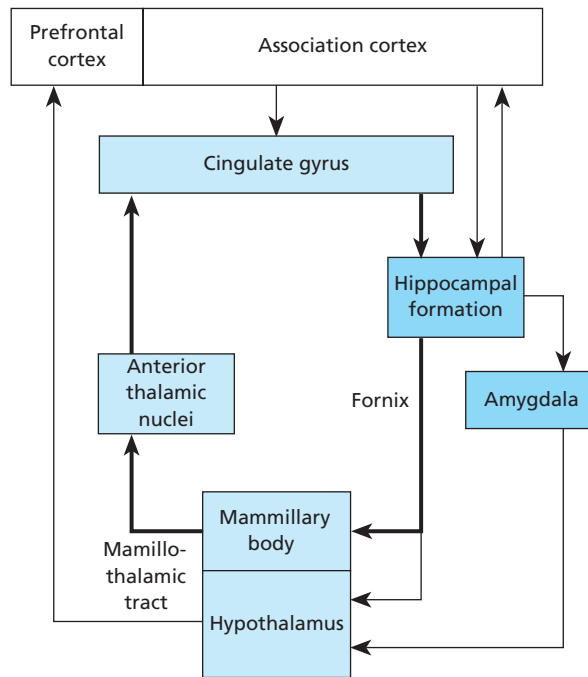

eliciting fear within a classical conditioning framework are relatively easy to control and undertake with animal subjects.

In animal studies, the fear-conditioning procedure may occur as follows. The organism is exposed to a tone or flash of light (the conditioned stimulus, CS), followed by a brief electric shock (the unconditioned stimulus, US). If the US is intense enough, then pairing the CS with the US will result in rapid conditioning of the fear response. This conditioning is measured by freezing responses, endocrine activity, autonomic activity, reflexes (eyeblink) or the degree to which the CS interferes with the organism's routine behaviour.

Using neuroanatomical staining and lesioning techniques, the pathway of an acoustic stimulus, for example (the CS), can be traced from the auditory system outwards after conditioning has taken place. In fact, lesioning the midbrain and thalamus along this pathway prevents conditioning, but lesioning the auditory cortex does not (LeDoux *et al.* 1984). Furthermore, the auditory thalamus projects to the auditory cortex and the amygdala. Lesioning the connections between the auditory thalamus and the amygdala interferes with conditioning. LeDoux and his colleagues observed that the lateral nucleus of the amygdala is the region responsible for receiving information about the auditory stimulus (LeDoux *et al.* 1990). Cells in this area are particularly responsive to stimuli similar to auditory conditioned stimuli.

The direct thalamic pathway to the amygdala is fast but carries few auditory impulses; the link to the amygdala from the thalamic pathway via corticocortical connections is slower but carries greater auditory impulses. Thus emotional responses associated with simple stimuli might be mediated by the first route; responses associated with complex

sets of stimuli may be mediated via the second route. It is thought that the lateral nucleus acts as the place where these two systems meet and possibly integrates information from the two parallel systems (LeDoux 1995b; see Figure 10.2).

The output region of the amygdala is considered to be the central nucleus. Lesioning the central nucleus affects the expression of emotion. The expression of particular emotional behaviour may also be impaired if certain areas to which the central nucleus projects are lesioned. For example, freezing responses are inhibited by lesions to the central grey area; neuroendocrine responses are affected by lesions to projections to the bed nucleus of the stria terminalis. To illustrate the extent of the amygdala's involvement in the acquisition and maintenance of fear learning, lesioning of the structure, even after extensive training, produces deficits in fear conditioning (Kim and Davis 1993). Similar pathways and circuitry are involved in the conditioning of fear to visual stimuli. However, the origin of the US's pathway to the amygdala is unknown.

When the amygdalae of rats are lesioned before fear conditioning, bilateral lesions interfered with the conditioning of fear to a tone and a context. Unilateral damage was associated with partial impairment in the ability to fear these stimuli (Baker and Kim 2004). However, when damage occurred after fear training, both types of lesion impaired fear learning. More significantly, although there were no left–right differences in the impairment seen for fear conditioning of a tone, rats with right-sided lesions showed impaired fear conditioning to context, suggesting that the right amygdala is more greatly implicated in fear conditioning than is the left.

The amygdala and fear in humans

Conditioning of fear appears to be a better protocol for examining the neural basis of emotion than is passive avoidance conditioning. However, as LeDoux (1995b) notes, whether the mechanisms of fear conditioning outlined from these studies are the same as

Figure 10.2 The amygdala pathways involved in fear conditioning (from LeDoux 1995a)

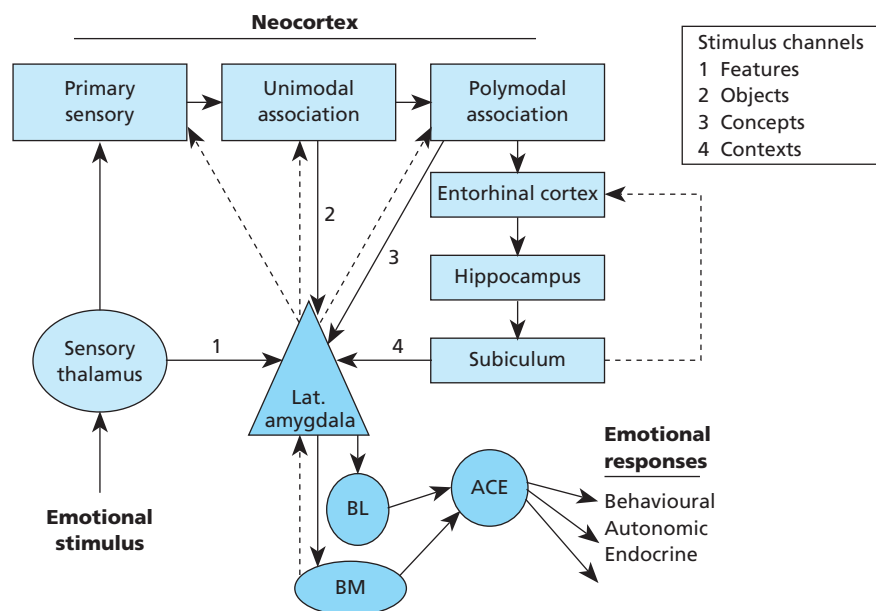

those that mediate other forms of fear specific to humans (e.g. fear of authority, heights, social situations) is unclear. LeDoux's protocol is also highly experimental and based on animal data. However, there is some evidence from the human literature that the amygdala is disproportionately involved in the perception of fearful or fear-related stimuli. In a case study of a 30-year-old woman who had sustained complete bilateral destruction of the amygdala (sparing the hippocampus and cortex), the patient was unable to recognize fear but could recognize happiness, surprise, anger, disgust and sadness in facial expressions. Neither could she recognize multiple emotions in a single facial expression (Adolphs *et al.* 1994). Adolphs and co-workers have also reported data showing that unilateral but not bilateral damage to the amygdala impairs the recognition of fearful facial expressions (Adolphs *et al.* 1995). In Figure 10.3, drawings from a patient with almost complete bilateral amygdala damage indicate an inability to draw a fearful facial expression from memory while being able to draw other types of emotional facial expression.

Figure 10.3

Patient SM-046's drawings of various emotional states. Note that she was unable to draw the fear expression (from Adolphs *et al.* 1995). © 1995 by the Society for Neuroscience

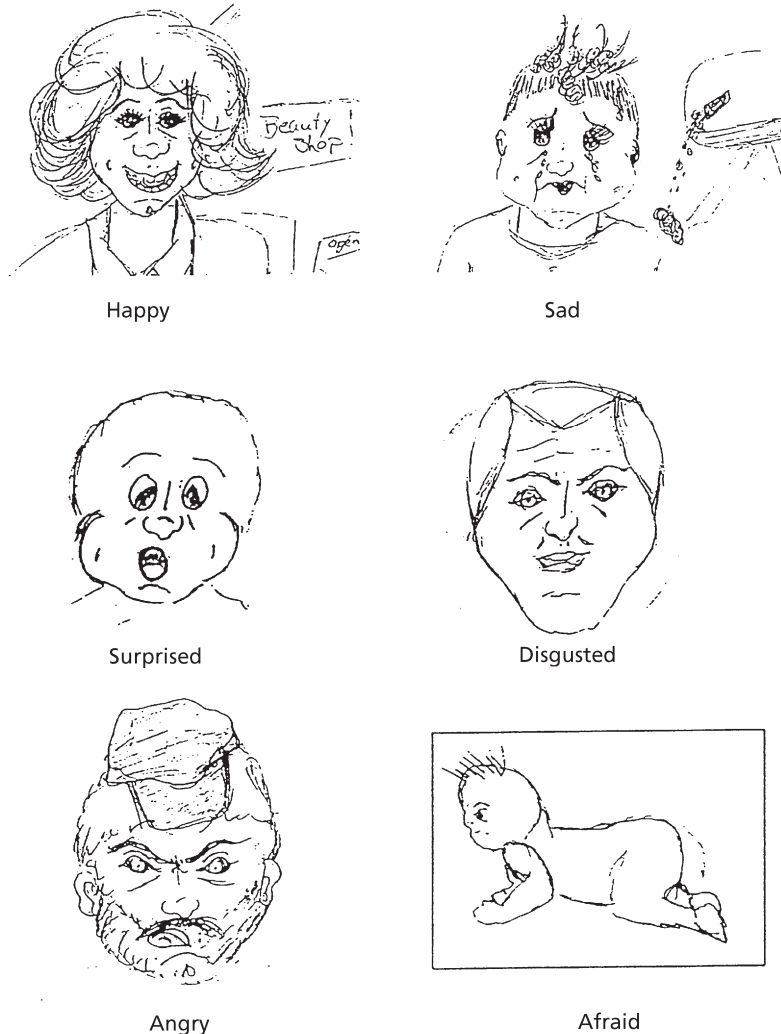

Neuroimaging data also suggest that the amygdala is more involved than other brain regions during the perception of fear-related material. For example, Morris *et al.* (1996) reported that not only did activation increase in the left side of the amygdala when individuals were watching fearful facial expressions but also that this activation was greater when the facial expression was more intense. Other fMRI and PET studies have confirmed this activation in the amygdala during the perception of fear in facial expressions (Morris *et al.* 1998) and in the perception of sad expressions, but not angry ones (Blair *et al.* 1999). Adolphs *et al.* (1999) reported a case study of a 31-year-old woman who sustained damage to both sides of her amygdala. While she was able to distinguish pleasant from unpleasant emotions in faces, words and sentences, she was unable to recognize emotional arousal in those expressions conveying negative emotions, specifically fear and anger. The authors argue that these results support a role for the amygdala in responding to highly negative, threat-related stimuli that require quick responses, although there are results showing that if we keep negative thoughts in mind, this maintenance, and the subsequent bad feeling it generates, is associated with increases in amygdala activity (Schaefer *et al.* 2002).

An interesting exception to this general pattern appears to be the response of cultures that may not attribute such obvious emotional overtones to faces. In one neuroimaging study, for example, fearful eyes (and eyes exhibiting other expressions) were presented to participants as brain activation was recorded. When the eyes were fearful but the mouth was neutral, increased activation in both amygdalae and the superior colliculus was reported in a Western sample (Morris *et al.* 2002). Figure 10.4 gives examples of the stimuli and brain scans from the experiment.

However, an fMRI study of response to fearful facial expressions that compared the brain activation of Caucasian and Japanese participants found the typical increased activation in the amygdala (and posterior cingulate and supplementary motor cortex) in the Caucasian sample but a different pattern of activation in the Japanese sample – increased right inferior frontal, premotor cortex and left insula activation, but no increases in the amygdala (Moriguchi *et al.* 2005). The results suggest that Caucasians respond to fearful stimuli in a direct, emotional way, an interpretation that may not be appropriate in the Japanese sample. The study provides a useful caveat – it demonstrates that a normally universally reported finding can be modified by a study's sample characteristics.

There is also evidence that, when a negative emotion other than fear is induced – e.g. sadness – the amygdala is more greatly activated in men than in women (Schneider *et al.* 2000). This pattern was replicated in an fMRI study of emotional arousal (Canli *et al.* 2002). Canli *et al.* recorded brain activation in men and women who reported emotional arousal to neutral or emotionally negative pictures. Three weeks after this session, the participants were invited back to the laboratory, where they completed a recognition memory test. The more emotional the pictures, the better they were remembered, and women recognized more of these than did men (women also rated these pictures as more intense). The neuroimaging data showed an unusual pattern, however. Even when the pictures were rated as arousing equally by men and women, different regions of the brain exhibited activation. There was greater activation in the right amygdala, insula and thalamus in men but activation in fewer regions in women. However, women activated the left amygdala more than did men, as Plate 10.1 shows.

Brain regions were more active when participants judged how arousing the pictures were and when they viewed pictures that they later successfully recognized. The authors speculate that the left-sided amygdala activation in women might reflect the adoption of a language-based strategy when evaluating the arousal of pictures. Other research, for example, has associated left-sided (rather than right-sided) activation in the amygdala with response to threats that are communicated verbally (Phelps *et al.* 2001).

Figure 10.4

The stimuli used in Morris *et al.*'s (2002) study and the brain activation observed (from Morris *et al.* 2002)

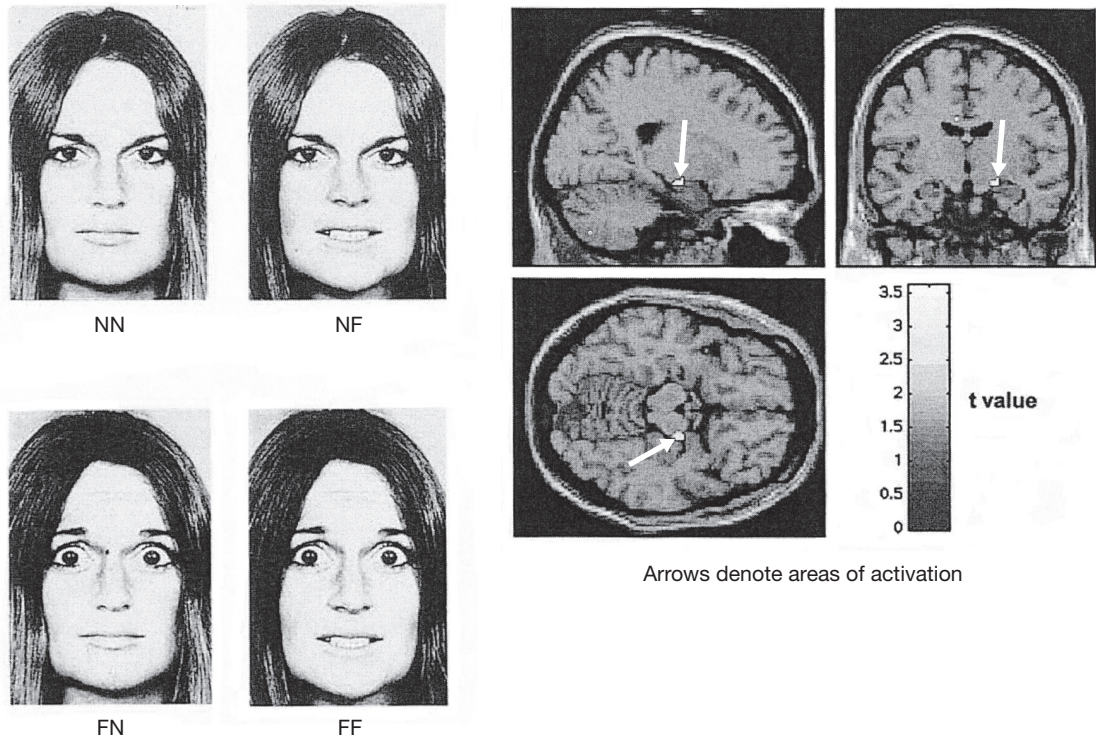

Arrows denote areas of activation

The amygdala's role in emotion does not appear to be tied to recognizing or generating negative emotion. There is evidence of activation in the amygdala during emotional memory retrieval, especially when the retrieval involves recalling the complex details of an emotional event rather than its general theme or 'gist' (Adolphs *et al.* 2005). Viewing positive stimuli has also been found to be associated with a significant increase in activation in the left side of the amygdala; this activation also extends to other brain areas known to be involved in drug addiction and reward. Watching diseased and mutilated bodies stimulated both sides of the amygdala (but little beyond it). The notion that the amygdala is active when encoding and retrieving positive memories suggests that its role here may be due to its role in remembering positive events. That said, the amygdala has many parts (and parts that PET may not have been sensitive enough to measure), and different regions within the structure may play different roles.

Lang *et al.* (2000) have suggested that negative emotion evolved as a motivational mechanism to help survival in dangerous environments. The amygdala is a structure that seems to be involved in a defence motivation circuit: that is, it facilitates orienting and the lowering of detection thresholds. When people are frightened, the amygdala is part of the system that allows us to flee from or fight the source of the threat. This motivational system is responsible for activating somatic states – such as those experienced during fear – which make us aware of threat and draw our attention to it. The role of such a system would be to help the organism to survive in a dangerous environment. Variations in activity in the system are responsible for the experience of stimulus-specific fear (such as

phobia) and generalized anxiety. The immediate nature of the orienting response to fear and the fact that animals are hyper-reactive to fear-cues suggests that the physiology of fear does not depend on linguistic processing or a language-based appraisal process.

Frontal lobes: happiness, sadness and inappropriate behaviour

The orbito-frontal lobe damage of Phineas Gage and others described in Chapter 5 has suggested a strong role for the frontal lobes in the regulation of emotion. Later studies supported the notion that these structures, and especially the orbito-frontal cortex, are responsible for the mediation or regulation of some forms of emotional expression and the inhibition of inappropriate emotional behaviour.

In one early study, for example, Kolodny (1929) described two consequences of frontal lobe lesion: mood alteration (exaltation or depression) and changes in the social aspects of personality. This study was not unique, with Holmes (1931) later arguing that frontal brain damage could result in increased indifference, depression or exuberance/euphoria. Closed-head injury patients with frontal damage have been found to exhibit symptoms of depression and withdrawal (Levin *et al.* 1979). Frontal patients are also found to be irritable or indifferent to the rules of social engagement (Stuss and Richard 1982). It is the peculiar and striking change in personality that partly informed the movement towards lobectomy for the removal of psychotic symptoms in the 1940s and 1950s. About 100 000 people underwent the frontal brain-lesioning procedure in this period. The earliest reports of lobectomy indicated that the main post-operative symptoms were inertia, lack of ambition, indifference and poor judgement (Freeman *et al.* 1942). However, two problems associated with these studies were that there was no formal testing of emotional perception or expression, and premorbid levels of emotional processing were not considered.

Later attention focused on the orbito-frontal cortex. Kleist (1934) suggested that this region was important to a unified sense of personality and that damage would result in deviant behaviour, puerility and euphoria. In fact, damage to this region is commonly associated with this behaviour (Blumer and Benson 1975; Stuss and Benson 1986).

There are other sources of evidence indicating the frontal lobes' neural involvement in emotion. Nauta (1971, 1973) has emphasized the prefrontal cortex's connections with the limbic system, arguing that it might regulate emotion by integrating sensory input from the external environment with information about the internal environment that is derived from the hypothalamus and other limbic structures. Rolls (1990, 1995) has similarly argued that the orbito-frontal cortex is an important structure in the disconnection of stimulus–reinforcement associations, the processes that Rolls believes make up our experience of emotions. The amygdala, Rolls suggests, may elicit learned emotional responses, while the orbito-frontal cortex may be involved in the correction 'or adjustment of these emotional responses as the reinforcing value of environmental stimuli alters'. Much of Rolls's evidence is derived from animal work. However, human data appear to confirm the frontal cortex's involvement in the perception and expression of emotion. More interestingly, these data indicate that the left and right frontal cortices may have different parts to play in emotion.

Hemispheric asymmetry and the recognition and expression of emotion

Early studies of emotion and the human brain focused on affective disturbances following head injury. A common finding among these and later studies was that left-sided lesions tended to be associated with depressive, negative symptomatology (such as crying, low self-esteem, misery), whereas lesions to the right hemisphere were associated with increased elevation and euphoria (Alford 1933; Goldstein 1939; Robinson and Benson 1981; Sackheim *et al.* 1982).

The right-for-emotion hypothesis, as couched in neuropsychological terms, was based on early anecdotal studies of patients with unilateral right hemisphere lesions (Hecaen and Angelergues 1962). However, the involvement of the left hemisphere suggested inter-hemispheric differences in emotional expression. Furthermore, there might also have been intrahemispheric differences, i.e. differences in activation within different regions of the same hemisphere. In emotion research, these brain regions are sometimes divided into anterior (pre-Rolandic fissure structures – the frontal lobes) and posterior regions (post-Rolandic fissure structures – parietal, temporal and occipital lobes).

On the basis of the evidence implicating the right hemisphere in emotion, Ross (1981, 1985) has suggested that the right hemisphere contains an emotional processor and that the production of emotion is associated with anterior regions, while comprehension is associated with posterior regions. However, it is important to note that there is a difference in the type of emotional processing that can occur. The difference lies in the distinction drawn between emotional perception and emotional expression. It is this difference that has given rise to conflicting evidence regarding the lateralization of emotion in the human brain, and it is important to treat each process separately.

Emotional perception

The ability to perceive or recognize emotions is thought to be, primarily, a right hemisphere function. If participants are asked (1) whether two emotionally toned sentences are the same or different, (2) to identify or discriminate between emotional facial expressions, or (3) to process neutral and emotional words, there is usually a left ear and left visual field advantage in these tasks, indicating the involvement of the right hemisphere. A left hemifield superiority for recognizing emotional versus neutral faces has been found (Bryden and Ley 1983), as has a left visual field advantage in the identification of facial emotional expressions with photographic, line-drawing, chimeric and cartoon stimuli (Strauss and Moscovitch 1981). Recently, an fMRI study of language comprehension in which speech varied by linguistic accentuation of emotional expressiveness found that the emotional (and linguistic) aspects of speech were associated with increased activation in the right dorso-lateral frontal cortex but only the emotional features activated the orbito-frontal cortex bilaterally (Wildgruber *et al.* 2004).

Findings from brain-lesioned individuals point to right hemisphere involvement in emotional expression. Borod *et al.* (1986a) and Etkoff (1984), for example, found that an impairment in the perception of emotional facial expression was associated more with right than left hemisphere damage. Recent studies have reaffirmed the importance of the right hemisphere in the perception of emotion in facial and prosodic stimuli (e.g. Schmitt *et al.* 1997). There may also be a specific role for the right hemisphere in the perception

of fear, although the perception of this emotion also disproportionately involves the amygdala (Schmitt *et al.* 1997; Adolphs *et al.* 1996).

The recognition of anger in voices appears to recruit different brain regions. When fMRI was used to compare activation during angry voice and neutral voice recognition, the middle superior temporal sulcus was more greatly activated when people heard angry prosody (Grandjean *et al.* 2005). Given the importance of this region to phonological processing, it was curious that the activation was observed even when acoustic amplitude and frequency in the angry voice was taken into account. There is also evidence that the ventral striatum may be involved in anger in humans (Calder *et al.* 2004). Four patients with lesions to this region were unable to identify anger and aggression in tasks in which participants were asked to identify emotions in voices, pictures and faces. Calder *et al.* interpret the role of the striatum evolutionarily – its function may be the pursuit of biological resources (such as food, a mate, territory); when challenges are made to this pursuit, the individual may become aggressive and angry. The ventral striatum may mediate such responses.

Emotional experience

The spontaneous expression of emotion is most commonly associated with left hemisphere activity (Wyler *et al.* 1987), although an absence of asymmetry has been reported (Hager and Ekman 1985). In an intriguing set of EEG studies by Richard Davidson and his colleagues, hemispheric asymmetries have been found in response to the experience of pleasant and unpleasant emotional visual stimuli (Davidson 1992; Davidson and Sutton 1995). The affective stimuli used in these studies were self-contained film clips, pre-rated for positive and negative affect (more naturalistic materials have been used elsewhere, e.g. Schelleberg *et al.* 1993).

Early EEG studies (e.g. Harman and Ray 1977) had suggested that affective response could be characterized by asymmetrical patterns of EEG activity. Specifically, increases in left hemisphere power were obtained during generation of positive memories, with decreases accompanying the generation of negative memories. Davidson and his colleagues later found greater relative left frontal hemisphere activation in the alpha frequency to positive film clips and greater right frontal hemisphere activation to negatively rated film clips (Davidson *et al.* 1979).

In a later study, Davidson and colleagues recorded EEG activity from the frontal and anterior temporal regions of eleven right-handed women as they watched standardized video clips designed to elicit positive or negative emotions (Davidson *et al.* 1990). In the positive condition, subjects watched clips of either puppies playing with flowers or monkeys playing or a gorilla taking a bath. In the negative condition, participants saw clips of a leg amputation and third-degree burns. Davidson *et al.* found greater alpha power (more activation) in the right frontal and anterior temporal regions during the negative ('disgust') than the positive ('happiness') condition. The positive condition was associated with greater left-sided activation in the anterior temporal regions than was the negative condition.

In a follow-up study, Ekman *et al.* (1990) reported more left-sided anterior temporal and parietal activation when participants exhibited the Duchenne smile (the 'natural' smile, which involves the movement of the zygomatic muscles and orbicularis oculi muscles) than other smiles. It is important to note that in all of these studies, the participants were women. It is unclear whether this should have any effect on the generalizability of the results, but the restricted sample should raise appropriate questions about the applicability of these findings.

Evidence from brain-damaged individuals indicates similar, but qualified, findings. Patients with damage to the right hemisphere as a result of a stroke have been found to be poorer at posing accurate spontaneous emotional expression than those with left lesions (Borod *et al.* 1986b). However, this picture is not that clear. In a study of patients with tumour and vascular complaints, for example, Mammucari *et al.* (1988) found no difference between left- and right-lesioned patients in their ability to make spontaneous emotional expression, although both clinical groups differed from controls. However, Weddell *et al.* (1990) found that anterior right- and left-lesioned patients were significantly more impaired than controls and posterior-lesioned patients when required to make accurate negative and positive emotion poses.

However, the general finding in these studies is that emotional perception is better when undertaken by the right hemisphere, whereas emotional expression implicates both hemispheres in the region of the frontal cortex. The question then arises, why should asymmetry exist for these two apparently discrete functions? Some models of laterality that might answer this question are discussed later.

Discussion point: the neuropsychology of humour

One emotional response that is frequently overlooked in discussions of emotion is mirth, probably because discovering the reasons for why we laugh are not as pressing as discovering why we cannot speak, see or hear. Great complexity underlies the behaviour subsumed under the term 'laughter'. Motor, sensory and cognitive systems interact to produce it. Despite its complexity, however, there is some evidence to indicate that this area might be a fruitful one for emotion research.

Humour is associated with increased heart rate (Averill 1969), skin conductance (Goldstein *et al.* 1975) and muscle tension (Chapman 1976), and with altered respiratory (Svebak 1975, 1977) and EEG patterns (Svebak 1982). At an anatomical level, right hemisphere damage appears to be consistently associated with irregularities in laughter, perception of humour and enjoyment of it. For example, right hemisphere damage has been associated with spontaneous outbursts of laughter (Sackheim *et al.* 1982), whereas anaesthetizing the right hemisphere also increases laughter (Perria *et al.* 1961). In a well-known study, Gardner *et al.* (1975) found that right hemisphere patients showed greater variability in their laughter (i.e. too much or too little) than did left hemisphere patients.

Right hemisphere patients also appear to have greater difficulty than controls in placing correct punchlines to cartoons, where the captions were classed as 'joking', '*non sequitur*', 'straightforward-neutral' and 'straightforward-sad' (Wapner *et al.* 1981). They placed the greatest number of *non sequiturs* as punchlines to the cartoons, an appropriate choice in that it made the cartoon funny, but it made the cartoon lack coherent meaning. Right hemisphere patients also showed differences in humour differentiation, with a tendency to give higher ratings to unfunny items. Winner and Gardner (1977) found that both left hemisphere patients and controls laughed at literal pictorial representations of metaphors, but right hemisphere patients did not. Interestingly, Brazzelli *et al.* (1994) reported a single-case study of a woman with bilateral frontal lobe damage who was unable to caption cartoons properly but did show signs of amusement and surprise when, after lifting a series of boxes and finding they were empty, lifted the final box and discovered that it was heavier than the others. Shammi and Stuss (1999) found that anterior right frontal lobe damage was more

frequently associated than was the left with damage to other brain regions with an impairment in the ability to appreciate humour, suggesting (or confirming) a role for the frontal cortex in integrating information (such as focusing attention on pictures and visually searching the visual environment when viewing cartoons).

These studies indicate that the right hemisphere may be important in the understanding of humour, although very few studies have systematically examined the neuroanatomical basis of laughter and the response to humour (see discussion in Martin and Gray 1996).

Emotional experience: anger and disgust

One of the few studies examining cortical responsiveness during anger found changes in the right orbito-frontal and cingulate gyrus of thirteen healthy young men as they decided whether facial expressions belonged to men or women (Blair *et al.* 1999). Each face expressed either sadness or anger and varied in intensity. As the intensity of the sadness expression increased, activity in the left amygdala and right temporal lobe increased; as the intensity of the angry expression increased, activity in the right orbito-frontal cortex and the anterior cingulate gyrus increased. Previous studies have linked ACC activation with the intensity of emotional facial expression. There was no significant increase in amygdala activity during exposure to angry expressions. The authors propose that the results signify a clear model: there is no unitary system that responds to negative stimuli but two systems. One system mediates responses to negative stimuli involved in social aversive conditioning (sadness, fear); the other mediates responses to negative stimuli (anger and related stimuli) that curtails behaviour (the emotion is thought to suppress behaviour).

There appears to be an association between the degenerative motor disorder Huntington's disease and the recognition of the emotion of disgust. Sprengelmeyer *et al.* (1996, 1997b) had reported that patients who showed symptoms of Huntington's disease were poor at recognizing facial expressions of disgust (but no other), a finding replicated by Gray *et al.* (1997), who investigated pre-symptomatic carriers of the disease. Patients with Gilles de la Tourette syndrome and obsessive-compulsive disorder also show this selective deficit in recognition (Sprengelmeyer *et al.* 1997a).

The region of the brain that is dysfunctional in HD and these disorders is the fronto-striatal area, especially the basal ganglia. Early fMRI research that explored the neuroanatomical basis of disgust recognition in healthy individuals found increased activation in the putamen – a part of the basal ganglia (Phillips *et al.* 1997; Sprengelmeyer *et al.* 1998). This region is also implicated in Parkinson's disease (PD), and this factor prompted Sprengelmeyer *et al.* (2003) to hypothesize that recognition of disgust might also be impaired in PD patients. They reported that medicated and unmedicated PD patients were poorer at recognizing disgust than was a control group; the unmedicated group gave the poorest performance.

However, the more recent neuroimaging data from healthy participants implicate more cortical regions in tasks where individuals recognize emotions. Using fMRI, Schienle *et al.* (2005) asked sixty-three women to rate how disgusting they considered forty generally disgusting scenes and forty neutral scenes to be. They found that activation was greater in the left orbito-frontal cortex, left medial OFC, occipito-temporal lobe and left and right amygdala when the women viewed the disgusting stimuli. A broadly similar result was reported in a group of men and women who viewed disgust- and fear-inducing pictures (Schienle *et al.* 2005). This study found increased activation in the left medial and dorso-

lateral PFC in both sexes. Curiously, Habel *et al.* (2005) reported activation in this area when a happy mood was induced in healthy men.

Schienze *et al.* interpret their results in terms of Rolls's theory of emotion. Briefly, however, Rolls (1999) has proposed that visual affective stimuli are initially processed by the occipital lobe. The ventral visual system then projects to the amygdala and PFC via the inferior temporal area. The PFC 'decides' on the reward value of the stimuli – do they afford reward or punishment? This 'decision' then leads to a behavioural outcome, and the individual either withdraws or approaches.

Hemispheric lateralization and emotion: neuroimaging data

A recent meta-analysis examined regions activated by emotions in sixty-five neuroimaging studies published between 1992 and 2002 (Wager *et al.* 2003). A clear finding was that it made little sense to refer to an individual hemisphere as being 'responsible' for expressing or perceiving emotion. The effects found were much more discrete.

The authors found that different systems appeared to mediate approach and withdrawal behaviour: the anterior prefrontal cortex for the former, the anterior cingulate cortex for the latter. The amygdala was consistently activated when people perceived fearful facial expressions but also when people perceived pleasant stimuli, perhaps reflecting the structure's role in noting stimuli in the environment that are salient in some way and that might affect our well-being (and not necessarily ones that are negative; there may be another, more specific, part of the amygdala that responds to those). When the participant's sex was also considered, men generally responded with more lateralized emotional brain activation than did women.

What is the relationship between the amygdala and the OFC in the context of emotional expression? One study has suggested that the OFC may modulate emotion (Hariri *et al.* 2000). They used fMRI to record activation in men and women who either indicated which emotional expression in two faces had been previously presented or identified the affect in a facial expression by selecting a label – 'afraid' or 'angry', for example. When participants matched expressions, there were significant increases in left and right amygdala activation; when they labelled, decreased left and right amygdala, and right PFC activation was observed.

On the basis of these data, it may be possible to argue that the PFC modulates the activity of the amygdala such that reasoning about an emotional stimulus will reduce the emotional impact of this stimulus (and this reduction will be reflected in concomitant reduction in the amygdala's activity).

Models of human emotional expression: neuropsychological perspectives

Two general models of the neuropsychology of emotional expression and perception have been proposed (although there are several more detailed ones, e.g. Rinn 1984). The right hemisphere hypothesis states that the right hemisphere is dominant for emotional perception and expression regardless of whether the emotion is positive or negative (Borod *et al.* 1983). The valence hypothesis argues that there is right hemisphere dominance for negative emotions and left hemisphere dominance for positive emotions (Silberman and

Weingartner 1986; Davidson 1992). This hypothesis is divided into two other hypotheses: one states that the valence hypothesis applies to both the perception and expression of emotion; the other states that the expression of emotion may be lateralized, but there is right hemisphere dominance for perception of emotion regardless of valence.

The evidence reviewed thus far indicates that the right hemisphere hypothesis does not adequately explain all the data currently available in neuropsychological studies of emotion. The number of studies demonstrating right hemisphere superiority for emotional perception and left hemisphere superiority for emotional experience suggests that this is too crude a model to account for the existing data. At the cortical level, the evidence appears to support the second model, specifically that positive emotional expression is confined to the left hemisphere and negative emotional expression is confined to the right hemisphere.

Davidson, for example, has interpreted the affective EEG findings in terms of approach and withdrawal behaviour (Davidson 1984, 1992). This hypothesis argues that affective differences between the two sides of the brain reflect different motivational tendencies (Ehrlichman 1987): an approachable stimulus will evoke positive emotional experience; an unapproachable stimulus (one provoking withdrawal) will evoke negative emotional experience. The evidence for the hypothesis has been obtained in EEG studies both from normal participants and from individuals scoring high on depression inventories. Schaffer *et al.* (1983), for example, found that depressed individuals showed less left frontal baseline activation than non-depressed individuals. Right frontal hemisphere EEG variability has also been reported in depressive patients (Perris *et al.* 1978). However, studies employing different experimental conditions such as induction of euphoric/depressive states or self-generated depression/sexual arousal have reported alpha symmetry or no left-sided activation (Tucker *et al.* 1981). It could be argued that these latter studies contain an element of motor and perceptual activity that is not present when viewing a film and rating it for its emotional content. The studies using film clips may therefore be more reliable in terms of the methods they employ. However, it should be noted that Harman and Ray (1977) also ask participants to generate emotional memories and reported increased left hemisphere power during positive affect when compared with negative affect.

It has been suggested that increased left frontal activation may be an index of the individual's capacity to respond to an emotional stimulus. Wheeler *et al.* (1993), for example, report that increased left frontal activation and decreased right frontal activation predicted greater affective response to positive films, whereas Tomarken *et al.* (1990) report that baseline asymmetry at frontal electrodes significantly predicted global negative affect. Tomarken *et al.* (1992) also found that those who showed more left-sided EEG were more likely to show positive affect, as Figure 10.5 illustrates.

Taken together with the reports of decreased left frontal activation in depressed individuals, these findings suggest a diathesis model of affective response. This means that the asymmetrical activation represents a predisposition to respond to emotional stimuli in a particular way. As Davidson (1988) notes: 'right frontal activation may be necessary but not sufficient for the experience of negative emotion. Its presence may mark a vulnerability for negative affect, given an appropriate elicitor'. Elsewhere, he argues that 'individual differences in frontal activation asymmetry [represent] a diathesis, which in combination with the requisite situational or contextual factors, will result in the predicted type of emotional response. Frontal asymmetry is thought to be neither sufficient nor necessary for the experience of approach-related positive and withdrawal-related negative emotion. Rather, frontal asymmetry is regarded as a contributory cause of such emotional states' (Wheeler *et al.* 1993).

The EEG and affective asymmetries have been criticized for their modest correlations and for the inconsistency in the findings they report (Hagemann *et al.* 2002). However,

Figure 10.5

The relationship between baseline left- and right-sided EEG activation, and positive and negative affect scores (from Davidson 2003)

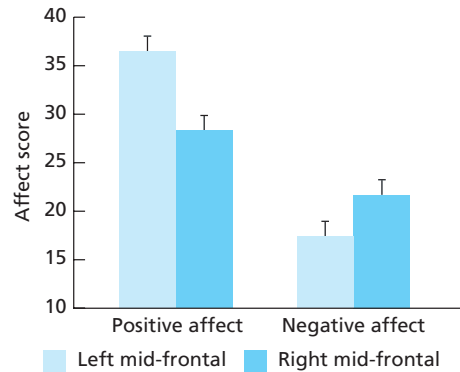

there are independent data supporting the general thrust of the asymmetry model. Using the approach–withdrawal model as his starting point, for example, Schmidt (1999) examined whether the resting brain activity in these regions would be different in shy and sociable individuals. The theory would predict that the more sociable the participant, the greater the left hemisphere activation; the more withdrawn and shy, the greater the right frontal activation. This is the pattern that Schmidt found. Schmidt has extended this work to show that musical excerpts that differed in emotional tone (positive/negative) and intensity could also produce regional changes in EEG activation (Schmidt and Trainor 2001). They recorded EEG activity in fifty-nine undergraduates (approximately half of each sex) while the participants listened to four excerpts of classical music. The excerpts had been pre-rated as either pleasant-calm, pleasant-intense, unpleasant-calm or unpleasant-intense.

Greater relative left frontal EEG activity was found when participants were listening to the pleasant excerpts and greater relative right frontal EEG activity was found when participants were listening to the unpleasant excerpts. No asymmetrical pattern of activation was found when the intense and calm excerpts were compared, but overall frontal cortex activity declined as the pieces became more intense. Activity declined through unpleasant-intense, pleasant-intense, pleasant-calm and unpleasant-calm. The results are consistent with the emotional asymmetry model outlined above and has extended the stimuli to which the model will be relevant to musical excerpts.

A similar finding was reported by Sutton and Davidson (2000), who measured resting brain activity (EEG) in men and women in two sessions separated by six weeks. In the second session, participants were given a word-pair judgement task. Participants were required to indicate which of two word pairs went together better. The words were manipulated for emotional tone so that some word pairs were pleasant and some were unpleasant (although the associative strength between words in all pairs was the same). Participants with greater relative left-sided activation were more likely to select the pleasant word pairs as being the two that went better together. The results, the authors suggest, show an attentional bias towards positive stimuli in healthy individuals who show frontal left-sided baseline EEG.

Resting brain activity has also been found to predict affective responses to physical exercise (Petruzzello *et al.* 2001). Their findings were similar to those of Sutton and Davidson: relative left-sided activity at baseline predicted degree of positive affect experienced after

exercise. The greater the left-sided activation, in other words, the better the mood of participants post-exercise. However, this prediction held only for the highly fit individuals. This suggests that resting baseline EEG and predisposition to positive affect may be mediated by other variables (such as fitness). Those with greater left-sided activity also expended the greatest energy. Extending this work in a new direction, Urry *et al.* (2004) hypothesized that similar, region-specific activation might be observed in people who showed high levels of psychological well-being. One form of this is defined as ‘the extent to which respondents endorse high levels of autonomy, environmental mastery, personal growth, positive relations with others, purpose in life and self-acceptance’ (*ibid.*: 367). Another form, ‘hedonic well-being’, refers to satisfaction with life, satisfaction with important domains such as work, high frequency of positive emotions and low frequency of negative emotions.

In Urry *et al.*'s study, eighty-four right-handed 57–60-year-olds completed various measures of well-being and had their EEG recorded in a single session. The researchers predicted that those expressing high levels of well-being would show greater left frontal EEG activation compared with right frontal EEG. The findings supported this hypothesis: highest levels on both measures of well-being were significantly associated with left frontal EEG activation.

Intriguingly, studies of infant response to separation from their mothers support the model. In one study, greater baseline right-sided frontal EEG activation was found to differentiate between those ten-month-old infants who became distressed (criers) when separated from their mother and those who did not (non-criers) (Davidson and Fox 1989). Fox *et al.* (1995) also found that 4-year-old children characterized as socially withdrawn during play exhibited greater relative right hemisphere frontal activation. This finding, they suggest, indicates that individual differences in EEG activation may reflect ‘in part, their pattern of affective responsivity and consequent social competence’, although the effects of the initial play experience cannot be ruled out as a confounding variable. The explanation may be *ad hoc*. A better test of the model would be, as Tomarken *et al.* (1990) have done with adults, to group the children according to individual EEG differences and see if these EEG-based groupings predict behaviour. This might also help to clarify the relative contribution of experience and physiology to individual differences and social behaviour. Does experience influence the individual differences in EEG, or does the EEG activation influence behaviour? A longitudinal study, as the authors themselves suggest, might partly answer this question.

Anger is conceivably an approach tendency, because there is motivation to engage in competitiveness or physical harm. Anger does not make people walk away; it is more likely to make them want to engage more in aggression and readies them for combat. But anger, by definition, is not necessarily a positive emotion. This therefore presents the theory with a paradox of sorts. If it genuinely is an approach tendency, we should see increased left frontal brain activity when people experience it. If this is found, this increase does not then give the left frontal lobe an exclusive role in positive affect – it can also be activated by a negative emotion. However, Harmon-Jones (2004) suggests that there may be an alternative explanation: that people who get angry actually like being angry, and anger can therefore be seen, via this logic, as a positive emotion.

To test this hypothesis, he took baseline EEG measurements from men and women and correlated this activity with their responses on an attitudes towards anger questionnaire. This questionnaire asked participants to agree or disagree with a series of statements about anger (e.g. ‘I like the feeling of power I get from expressing anger’). Measures of aggression were also taken and were used to divide the participants into those who expressed high levels of trait anger. The results showed that the most angry and aggressive of the group showed greater left frontal brain activity than did their milder counterparts. There was no significant relationship between attitudes towards anger and

brain asymmetry: those who found anger to be a positive emotion were no more likely than those who did not view it so to produce left frontal EEG. The study is important because it suggests that the role of the frontal cortex in emotion might be more usefully seen as one involving motivational tendencies rather than emotional valence.

Summary

There is ambiguity concerning what ‘emotion’ actually is, although there is some evidence from neuroscience that some emotions may be differentiated (1) on the basis of neural pathways and (2) on the basis of gross measures of regional brain activity. Data from animal studies have highlighted the importance of the amygdala, brainstem and hippocampal system in fear conditioning. Whether the highly stylized tasks used in animal studies make good analogues of human fear and anxiety is open to question. Studies of brain injury indicate that different areas of the neocortex are involved in the perception and expression of emotion. The left hemisphere appears to be superior for the experience or expression of emotion, whereas the right hemisphere is superior for the recognition and perception of emotion. Evidence suggests that activation of the left frontal cortex is associated with positive emotional expression, whereas activation of the right frontal cortex is associated with negative emotional expression. These patterns are thought to reflect approach–withdrawal behaviour: some individuals exhibit a predisposition to respond positively (approach) or negatively (withdrawal) to emotional stimuli.

Recommended further reading

General

- Ashby, F.G., Isen, A.M. and Turken, A.U. (1999). A neuropsychological theory of positive affect and its influence on cognition. *Psychological Review*, 106, 3, 529–50.
- Canli, T. and Amin, Z. (2002). Neuroimaging of emotion and personality: scientific and ethical considerations. *Brain and Cognition*, 50, 414–31.
- Damasio, A.R. (1999). *The Feeling of What Happens*. Oxford: Academic Press.
- LeDoux, J.E. (1996). *The Emotional Brain*. Englewood Cliffs, NJ: Simon and Schuster.
- LeDoux, J.E. (2002). Emotion, memory and the brain. *Scientific American*, 12, 1, 62–71.
- Rolls, E.T. (1999). *The brain and emotion*. Oxford: Oxford University Press.
- Special issue of the *Journal of Cognitive Neuroscience* on ‘Social cognitive neuroscience’, 2004, 16, 10.
- Wager, T.D., Phan, K.L., Liberzon, I. and Taylor, S.F. (2003). Valence, gender, and lateralization of functional brain anatomy in emotion: a meta-analysis of findings from neuroimaging. *NeuroImage*, 19, 513–31.

The amygdala

- Adolphs, R., Russell, J.A. and Tranel, D. (1999). A role for the human amygdala in recognizing emotional arousal from unpleasant stimuli. *Psychological Science*, 10, 167–71.
- Adolphs, R., Tranel, D., Damasio, H. and Damasio, A.R. (1994). Impaired recognition of emotion in facial expressions following bilateral damage to the human amygdala. *Nature*, 372, 669–72.

- Anderson, A.K. and Phelps, E.A. (2000). Expression without recognition: contributions of the human amygdala to emotional communication. *Psychological Science*, 11, 2, 106–11.
- Blair, R.J.R., Morris, J.S., Frith, C.D., Perrett, D.I. and Dolan, R.J. (1999). Dissociable neural responses to facial expressions of sadness and anger. *Brain*, 122, 883–93.
- Hariri, A.R., Bookheimer, S.Y. and Mazziotta, J.C. (2000). Modulating emotional responses: effects of a neocortical network on the limbic system. *Neuroreport*, 11, 43–8.
- McGaugh, J.L. (2004). The amygdala modulates the consolidation of memories of emotionally arousing experiences. *Annual Review of Neuroscience*, 27, 1–28.
- Morris, J.S., Friston, K.J., Buchel, C., Frith, C.D., Young, A.W., Calder, A.J. and Dolan, R.J. (1998). A neuromodulatory role for the human amygdala in processing emotional facial expressions. *Brain*, 121, 47–57.
- Morris, J.S., Frith, C.D., Perrett, D.I., Rowland, D., Young, A.W., Calder, A.J. and Dolan, R.J. (1996). A differential neural response in the human amygdala to fearful and happy facial expressions. *Nature*, 383, 812–15.
- Scott, S.K., Young, A.W., Calder, A.J., Hellowell, D.J., Aggleton, J.P. and Johnson, M. (1997). Impaired auditory recognition of fear and anger following bilateral amygdala lesions. *Nature*, 385, 254–7.

Anger and aggression

- Calder, A.J., Keane, J., Lawrence, A.D. and Manes, F. (2004). Impaired recognition of anger following damage to the ventral striatum. *Brain*, 127, 1958–69.
- Harmon-Jones, E. (2004). On the relationship between frontal brain activity and anger: examining the role of attitude toward anger. *Cognition and Emotion*, 18, 3, 337–61.
- Tebartz van Elst, L., Woermann, F.G., Lemieux, L., Thompson, P.J. and Trimble, M.R. (2000). Affective aggression in patients with temporal lobe epilepsy. *Brain*, 123, 234–43.

EEG asymmetry and positive and negative emotion

- Davidson, R.J. (2003). Affective neuroscience and psychophysiology: toward a synthesis. *Psychophysiology*, 40, 655–65.
- Davidson, R.J. and Irwin, W. (1999). The functional neuroanatomy of emotion and affective style. *Trends in Cognitive Science*, 3, 1, 44–54.
- Fox, N.A., Henderson, H.A., Rubin, K.H., Calkins, S.D. and Schmidt, L.A. (2001). Continuity and discontinuity of behavioural inhibition and exuberance: psychophysiological and behavioural influences across the first four years of life. *Child Development*, 72, 1, 1–21.
- Hagemann, D., Naumann, E., Becker, G., Maier, S. and Bartussek, D. (1998). Frontal brain asymmetry and affective style: a conceptual replication. *Psychophysiology*, 35, 372–88.
- Hagemann, D., Naumann, E., Thayer, J.F. and Bartussek, D. (2002). Does resting electroencephalograph asymmetry reflect a trait? An application of latent state-trait theory. *Journal of Personality and Social Psychology*, 82, 4, 619–41.
- Reid, S.A., Duke, L.M. and Allen, J.J.B. (1998). Resting frontal electroencephalographic asymmetry in depression: inconsistencies suggest the need to identify mediating factors. *Psychophysiology*, 35, 389–404.
- Schmidt, L.A. (1999). Frontal brain electrical activity in shyness and sociability. *Psychological Science*, 10, 4, 316–20.
- Stuss, D.T., Gow, C.A. and Hetherington, C.R. (1992). ‘No longer Gage’: frontal lobe dysfunction and emotional changes. *Journal of Consulting and Clinical Psychology*, 60, 3, 349–59.
- Urry, H.L., Nitschke, J.B., Dolski, I., Jackson, D.C., Dalton, K.M., Mueller, C.J., Rosenkranz, M.A., Ryff, C.D., Singer, B.H. and Davidson, R.J. (2004). Making a life worth living: neural correlates of well-being. *Psychological Science*, 15, 6, 367–72.

11

The dementias

- Dementia
- Dementia of the Alzheimer type
 - Clinical features
 - Neuropathological features
 - Neurochemical features
- Aetiology of Alzheimer's disease
 - Genetic factors
 - Transmissible agents
 - Nasal infection
- Treatment of Alzheimer's disease
- Vascular dementia
- Pick Complex
- Fronto-temporal lobe dementia
- Lewy body dementia
- Parkinson's disease and Huntington's disease
- Subcortical dementia
- Alcoholic dementia
- Korsakoff's psychosis
 - Clinical features
 - Neuropathological features
- Dementia associated with infection
 - Viral dementia
 - Postinfectious encephalomyelitis
 - Human immunodeficiency virus type I encephalopathy
 - Creutzfeldt–Jakob disease
- The neuropsychology of ageing
- The process of ageing
 - Memory
 - Processing speed and the frontal lobes
- Summary
- Recommended further reading

Dementia

Dementia describes a condition in which there is a gradual, insidious and relentless loss of cognitive function. There are several different types of dementia presenting different symptoms, which can create a difficulty in making a certain diagnosis of a specific dementia (Stuss and Levine 1996). There is also the added problem of cognitive decline

with increasing age. Normal cognitive decline may mask the early appearance of dementia, because memory impairment, difficulty in name finding and increased reaction times occur among the healthy aged. The degree of intellectual competence in the elderly population is itself varied, which can lead to the misdiagnosis of dementia in individuals of poor intelligence (Gurland 1981).

The *Diagnostic and Statistical Manual* (American Psychiatric Association 1994) lists the main clinical and behavioural symptoms that should appear in order to confirm a diagnosis of dementia. It also lists all the major diagnosable dementias. These are:

- dementia of the Alzheimer type;
- vascular dementia;
- dementia due to HIV disease
- dementia due to head trauma;
- dementia due to Parkinson's disease;
- dementia due to Huntington's disease;
- dementia due to Pick's disease;
- dementia due to Creutzfeldt–Jakob disease;
- dementia due to other general medical conditions;
- substance-induced persisting dementia;
- dementia due to multiple aetiologies;
- dementia not otherwise specified.

A diagnosis of dementia is decided on the basis of a set of key clinical, histopathological and localization factors. According to the *DSM-IV*, the diagnostic criteria for dementia are a demonstrable impairment in short- and long-term memory; the ability of memory/cognitive impairment to interfere with work, social activities and relationships; evidence of an organic factor that is 'aetiologically related' to the disturbance; and at least one of the following: abstract thinking impairment, impaired judgement, higher cortical function disturbance (aphasia, apraxia, agnosia) or personality change.

Further differentiation of diagnosis can be made by considering the site and the histology of the dementia (these two factors help to determine which type of dementia the patient is exhibiting). Histopathology is probably the criterion that is least susceptible to interpretation, because the molecular and biochemical evidence is clear-cut. Because of this, the only certain confirmation of a diagnosis of dementia can be made by autopsy or biopsy (McKhann *et al.* 1984).

Different types of dementia affect different brain systems and present slightly different clinical symptoms. The degenerative disease Alzheimer's disease (AD) is the most common cause of dementia, occurring in approximately 45 percent of demented patients in the USA (Cummings and Benson 1992) and with an estimated prevalence of 3.75 million worldwide (Stuss and Levine 1996). The disease was named after Alois Alzheimer, who in 1907 reported the case of a 56-year-old patient with abnormal formations called presenile plaques and tangles in her brain. She exhibited an obvious form of presenile dementia, to which Alzheimer gave his name. This dementia is referred to as dementia of the Alzheimer type or DAT.

Dementia of the Alzheimer type

According to the *DSM-IV*, dementia of the Alzheimer type is characterized by:

- cognitive decline exemplified by memory impairment (learning new information and recalling previously learned information) and one or more of aphasia, apraxia, agnosia and executive function problems;
- symptoms that cause significant decline from previous level of functioning;
- gradual onset and continuing cognitive decline;
- symptoms that are not due to other progressive CNS diseases or conditions causing dementia.

It is estimated that between 5 and 10 percent of individuals over 65 years of age will develop Alzheimer's disease (Rocca *et al.* 1986; Ritchie 1997). The disease accounts for approximately 50 percent of all cases of dementia (Fields 1998). American studies show a 50 percent incidence in people over 85, and 100 percent incidence in one Dutch study of nineteen centenarians (Evans *et al.* 1989; Hebert *et al.* 1995; Blansjaar *et al.* 2000). The percentage affected increases with age. Other studies suggest that some centenarians (around 30 percent) are impervious to the disease (Andersen-Ranberg *et al.* 2001; Silver *et al.* 2001; Hagberg *et al.* 2001). There is also evidence that individuals over 65 years old who are later diagnosed with the disease show evidence of neuropsychological impairment at least three years before the diagnosis (Amieva *et al.* 2005).

The disease can occur sporadically or in a genetic form called familial Alzheimer's disease. The familial form is thought to be autosomal dominant, with the gene carried on chromosome 21 and, possibly, chromosome 19. The gene expresses itself by producing the amyloid precursor protein from which the protein associated with the senile plaques is formed. Early-onset AD is associated with this marker and also with mutations on chromosomes 1 and 14 (Bird 1999). Evidence from Scandinavian studies suggests that the heritability of Alzheimer's disease is between 0.6 and 0.75 (Gatz *et al.* 1997). The $\epsilon 4$ allele of the apolipoprotein gene also appears to be a risk factor in Alzheimer's disease and for cognitive impairment (Farrer *et al.* 1997; Slioter *et al.* 1997).

Clinical features

The major cognitive impairment in AD is loss of memory. This impairment is gradual and occurs in the presence of a normal level of consciousness but in the absence of any other CNS disease that might account for the symptoms. The more marked deficits in memory include:

- an inability to recall autobiographical information from long-term memory (information about people, events and conversations, for example), the major characteristic of the disease and one that appears early in the disorder's development (Greene and Hodges 1996a; Fleishman and Gabrieli 1999);
- impaired recall of previously learned information and, sometimes, memory for conceptual or factual information;
- rapid forgetting;
- explicit memory impairment (implicit memory is relatively preserved);

- short- and long-term memory impairment (Fleishman and Gabrieli 1998);
- tendency to show a lack of a primacy effect but show a recency effect – patient will more correctly recall items from the end of a list than the beginning (Bayley *et al.* 2000);
- interference by previously learned information when new material is learned;
- attention and working memory impairment;
- semantic memory impairment – inability to recall over-learned information;
- circumlocution and paraphrastic errors;
- delayed-memory impairment – this appears to be best at discriminating DAT patients from controls (Zakzanis *et al.* 1999).

When Greene and Hodges (1996b) compared public memory (such as the ability to identify famous faces and names) and autobiographical memory (reporting events that occurred in childhood) in twenty-four patients with Alzheimer's dementia during the course of one year, they found that, although both public (famous face and name processing) and autobiographical memories were impaired in Alzheimer's patients, only public memory deteriorated longitudinally. This, the authors argue, indicates the fractionation of remote memory. It would be intriguing to read the results from a study in which an autobiographical version of the famous faces exercise was used.

One of the neuropathological features of Alzheimer's disease is degeneration of the amygdala and other brain structures involved in emotional processing (Callen *et al.* 2001). The psychological implication of this would be that, because the dementia's primary cognitive symptom is memory impairment, memory for emotional material may be especially vulnerable. However, the evidence for this is mixed.

To test the hypothesis explicitly in a real-life context, Budson *et al.* (2004) examined memory and emotional response to the attack on the World Trade Center on 11 September 2001 in a group of twenty-two patients with Alzheimer's disease, twenty-one with mild cognitive impairment (MCI) and a group of twenty-three healthy, elderly adults. The samples' responses were measured two–three weeks after the event and three–four months later. As might be predicted from studies of flashbulb memory, personal information surrounding the event (i.e. what they were doing when the planes crashed) were better remembered than was factual information. This difference was largest in the AD patients. At a follow-up session, AD patients remembered more personal than factual information, but the other two groups remembered the two types of information equally well. However, these personal recollections were more subject to distortion, especially in the demented group.

Some psychologists have suggested that attention may also be an early cognitive characteristic (Perry and Hodges 1999). However, what is unclear is whether this deficit in attention is a global and unitary one – where all types of attention are impaired – or whether different types of attention are affected differently (Baddeley *et al.* 2001). Baddeley *et al.* administered three tests of attention to three groups of participants: a group of forty-one patients diagnosed with probable Alzheimer's disease, a group of thirty-six age-matched controls and a group of thirty-six young controls. In the first attention test, participants performed simple and choice reaction time exercises that involved pressing a key whenever a stimulus appeared on a monitor (this was called a test of focal attention). The second test investigated the participants' ability to ignore distractors in a visual search task (for example, ignoring other letters when looking for the letter 'Z' in an array of letters). The third test involved the ability to divide attention between two exercises simultaneously performed. In each of the tests, there were two levels of difficulty.

So, for the visual search task, for example, participants looked for the letter 'Z' in an array of similar or dissimilar (difficult condition) letters. Baddeley *et al.* hypothesized that participants with Alzheimer's disease would perform significantly more poorly than the control group at the difficult versions of the tasks.

Whereas both groups were impaired at the normal and difficult versions of the choice reaction time task, there was no significant difference between the two groups, indicating that this type of attention may be relatively immune to the effects of Alzheimer's disease. However, the ability to ignore distractors in a visual search exercise was significantly impaired in Alzheimer's disease (although both demented and old performed worse than the young). The greatest effect of the disease was found in the dual-task exercise – performance on this task was significantly worse in the Alzheimer group than the control group. The results suggest that attention is not globally affected by Alzheimer's disease – providing evidence against the unitary hypothesis – but that there is selective impairment in attention, specifically divided attention.

As well as selective impairments in attention, people with Alzheimer's disease also experience other subtle and more pronounced difficulties. Memory impairments, such as disorientation over finding their homes, forgetting people's names and faces and not being able to follow the flow of a conversation, are key features. However, the inability to comprehend sentences is more subtle, and some psychologists have suggested that this deficit stems not from some linguistic problem or decline but from a working memory impairment, similar to that seen when failing to follow conversation (Baddeley *et al.* 1991).

The linguistic problems found in AD include impairments in comprehension and naming and an inability to utter speech with coherent or semantically accurate content. Both semantic knowledge and concept formation are poor in AD patients. Learning new information is difficult, and reduced visual memory span has been reported (Albert and Moss 1983). Demented patients will recognize and correct syntactic errors, but mildly demented patients have difficulty correcting semantic errors. In the early stages, conversational speech is relatively normal with few solecisms. However, speech content is abnormal, with anomia and a reliance on stock phrases. Reading ability is preserved, but reading comprehension is poor. Patients also exhibit deficits in drawing, copying, constructional ability, left–right topographical orientation and perceptual discrimination. A famous case of an individual with DAT is Iris Murdoch. Unlike most other individuals with AD, her experience shows how the disease directly affected her work – work that would inevitably be affected by it. The box below describes the effect the disease exerted on her final novel.

The problem of *Jackson's Dilemma* – dementia and the novelist: the case of IM

Fellow novelist A.S. Byatt spared no sensitivity when she reviewed Iris Murdoch's last novel, *Jackson's Dilemma*. The book, Byatt averred, was 'an Indian rope trick ... in which all the people have no selves and therefore there is no story and no novel'. However, Murdoch was no novelistic novice. In 1978, she won the Booker Prize for *The Sea, The Sea*, and she was made Dame Commander of the British Empire in 1987 in recognition of her contribution to literature. Published criticism is an occupational hazard in the novelist's world, but Byatt's criticism may have unwittingly reflected an organic, rather than creative, decline. Murdoch was diagnosed with Alzheimer's



© Bassouls Sophie/Corbis Sygma

disease at the age of 76, just after she had finished writing *Jackson's Dilemma*; a *post mortem* three years later confirmed the diagnosis.

Following the suspected diagnosis of AD, Garrard *et al.* (2005) monitored structural changes in Murdoch's brain as part of her neurological assessment. In 1997, there was evidence of global atrophy, especially in the hippocampus (bilaterally), as seen in Figure 11.1.

When *Jackson's Dilemma* was published in 1995, the author had suffered severe writer's block and had become unexpectedly inarticulate at a question and answer session with the public a year later. The following summer, she was only able to describe her surroundings by reference to a city name and was unable to subtract or spell backwards. Her picture naming became circumlocutory: a bus was described as 'something carried along'; and her spelling became regularized. She would spell cruise as 'crewse', for example. Her retrograde memory was profoundly impaired, and her narrative speech was grammatical but lacked real content. For example: 'the girl is just holding a plate and various pieces of ... well ... something useful ... standing at a window ... whether the window is open is not quite clear to me. The thing where the water is running out. The girl doesn't bother. The window is open. Plate and two cups'.

Murdoch's disorder afforded Garrard *et al.* the opportunity to examine any relationship between the novelist's intellectual decline and the external manifestation of that decline – her final novel. The novelist regarded the work as being a true reflection of her output and requested no alterations be made to the text. Garrard *et al.* compared the vocabulary, syntax, grammatical class and lexical differences in this novel, in *Under the Net* (published in 1954) and in *The Sea, The Sea*.

The researchers found that vocabulary was rich and innovative in the early work but was impoverished in the final novel. The number of words and class of words per sentence (ten sentences were taken from the first, middle and final chapters of each novel) was smallest in the last novel. There was no difference in word length between the novels, but the final work contained more high-frequency words, reflecting a decline in

Figure 11.1

IM's MRI scans (from Garrard *et al.* 2005. Image kindly supplied by Peter Garrard and used by permission of Oxford University Press)

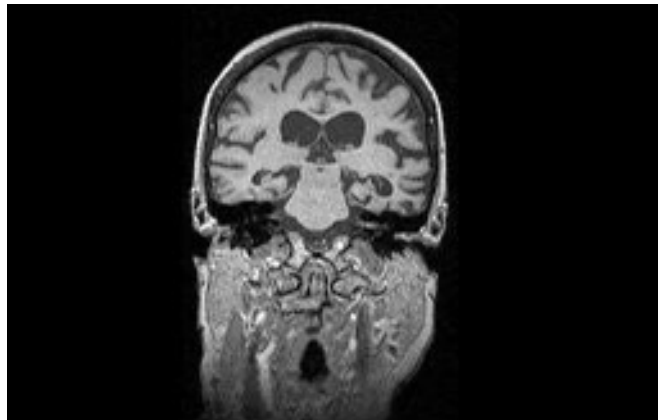

linguistic innovation. According to Garrard *et al.*, the use of high-frequency words is typical of temporal lobe pathology.

In a sense, these data are correlational. The final novel exhibited the features described here, and these features coincided with the development of the author's degenerative disease. Nonetheless, the data obtained from the analysis of the author's physical output reflect the behaviour observed by those closest to her.

Cummings and Benson (1992) suggest that AD develops in three stages. In the first stage (within three years), memory for recent (and some remote) events is impaired. New learning is impaired. Spatial perception declines, disorientation in time and place occurs and concentration is impaired. The patient feels fatigued, restless, apathetic and sometimes sad. There is impaired verbal fluency and mild anomia. In the second stage (within two to ten years), memory failure progresses, with impaired recent and remote memory recall, and parietal lobe dysfunction such as dyspraxia and agnosia occur. Judgement and the capacity for abstract thought disappear. Patients are anomic and have difficulty understanding speech. In the third and final stage (between eight and twelve years), all intellectual function breaks down. Gross emotional disinhibition and disorientation occurs, and the former personality is lost. Patients reach the stage where they cannot recognize relatives, or even recognize themselves in a mirror. Behaviourally, DAT patients may be socially withdrawn and apathetic, and depression is a commonly experienced disorder. There may be paranoia and examples of the misidentification syndrome – believing a carer is an impostor.

Neuropathological features

Post mortem, the brains of AD patients show shrinkage primarily of the frontal and temporal gyri (up to 20 percent) and ventricle enlargement. There is the possibility that the shrinkage is due to normal ageing, because not all AD patients exhibit shrinkage. There is neuronal loss in the cortex, hippocampus, amygdala, basal forebrain, locus coeruleus, raphe nuclei and nucleus basalis of Meynert. Plates 11.1, 11.2 and 11.3 illustrate the cortical shrinkage in AD.

The classic pathological symptoms of AD are (1) neurofibrillary tangles, (2) senile plaques, (3) granulovacuolar degeneration and (4) Hirano bodies. (1) and (2) are illustrated in Plates 11.4 and 11.5. There are abnormal amyloid protein deposits in both intracellular and extracellular sites in the demented individual's brain (Muller-Hill and Beyreuther 1989). Neurofibrillary tangles are straight or paired helical filaments that collect intracellularly and are made up of special proteins. Tangles normally consist of a pair of helical filaments found in the cytoplasm of cortical and hippocampal pyramidal cells. Ubiquitin, the protein marker for cell degeneration, has been localized in tangles (Gallo and Anderton 1989) and the amyloid B-protein that they contain may be responsible for the formation of the senile plaques (Anderton 1987). Temporal, parietal and frontal areas are especially affected by tangles. The tangles do not appear with normal ageing, although they are found in other dementias. Senile plaques are spherical and are made up of glia and abnormal nerve cell processes; these surround the extracellular amyloid proteins (usually B-amyloid, an amino acid peptide). Senile plaques in the cortex are more pronounced in AD patients than in age-matched controls. They are 15–20 µm in diameter and have an outer rim of abnormal neuronal processes called neurites. The formation of plaques precedes neuronal loss. Some patients exhibit tangles but not plaques. Granulovacuolar degeneration occurs primarily in the hippocampus and, as the name suggests, results in neuronal tissue becoming full of holes. Finally, Hirano bodies are rod-shaped material that intrudes on neurons. The malformations appear most commonly in the hippocampus and entorhinal cortex in the early stages of the disease, later extending to the frontal, temporal and parietal lobes. Hippocampal and entorhinal abnormalities have been found to correlate with the severity of episodic memory impairment in the disease (Cahn *et al.* 1998).

Brain-imaging studies indicate parietal lobe dysfunction, with extensive degeneration in the hippocampus and at temporal sites (Friedland *et al.* 1985; Esiri *et al.* 1990). Right temporal lobe and right hippocampal volume have been found to correlate with face recognition (Cahn *et al.* 1998); explicit memory test performance is associated with less activation in the medial temporal lobe and fusiform area in AD patients than in controls (Golby *et al.* 2005). Wilcock *et al.* (1988) have suggested that parietal lobe involvement occurs with early onset and temporal lobe involvement occurs with later onset of the dementia. There is evidence of hypermetabolism in AD patients (Procter *et al.* 1988) as well as early, asymmetric glucose metabolism reduction in frontal, parietal and temporal regions (Haxby *et al.* 1990). Areas of metabolic reduction tend to be positively correlated with neuronal degeneration (Najlerahim and Bowen 1988a, b).

Neurochemical features

There is a loss of synapses in the AD brain, which appears to correlate with the loss in intellectual function (Terry *et al.* 1991). It is known that certain neurotransmitter receptors are lost in AD, these include cortical acetylcholine, acetylcholinesterase and nicotinic receptors. In the mid-1970s, it was found that a loss of up to 70 percent of choline acetyltransferase, the cholinergic marker enzyme that synthesizes acetylcholine (ACL), occurs in the temporal and parietal cortices of AD patients. This acetylcholine synthesis impairment is correlated with the severity of the dementia, and the loss of choline acetyltransferase is correlated with the number of senile plaques and the degree of dementia (Perry *et al.* 1978). The cholinergic pathways linking the nucleus basalis of

Meynert to the cerebral cortex and those linking the septum to the hippocampus are both lost in AD, a finding that has given rise to the possibility that grafting neural tissue to replace the loss of connection might produce an alleviation of cognitive decline (Sinden *et al.* 1995). This role of the cholinergic system in memory was encouraged by studies in which scopolamine, a cholinergic antagonist, produced amnesia in healthy individuals. Scopolamine was normally administered with analgesia during surgery; women in labour would report not being able to recall events during the delivery when they were given scopolamine (Thal 1992). Experiments with healthy individuals indicated impaired non-verbal IQ but not verbal IQ following administration of scopolamine (Drachman and Leavitt 1974).

Based on the effects of scopolamine on both neurochemistry and cognition, work began into developing pharmacological treatment that would prolong the action of acetylcholine. One such drug, physostigmine, appeared to have a significant positive effect on verbal and non-verbal memory when given intravenously (Christie *et al.* 1981). Oral administration was not as successful (Thal 1992). A second drug, tetrahydroaminoacridine, also appears to produce improvements in verbal memory (Kaye *et al.* 1982). However, the response to these and other drugs is variable. Thal (1992) suggests that this variability and the lack of success of agents in increasing ACh are due to a number of factors, among them the fact that some agents are poorly absorbed, do not cross the blood/brain barrier and have severe side-effects. In short, because our understanding of the psychopharmacology of the cholinergic system and of these drugs is poor, psychopharmacological interventions in AD have not been uniformly successful.

In addition to the cholinergic system, other neurotransmitter systems have been implicated in AD. For example, 5-HT and noradrenaline neuron markers have been found to be reduced in the cortex of AD patients (Mann *et al.* 1982), a reduction possibly due to the loss of projections from the dorsal raphe and locus coeruleus to the cortex. Reductions in the concentrations of cortical noradrenaline and the metabolite 3-methoxy-4-hydroxy-phenylglycol have been found in AD patients, especially in the cingulate gyrus. Similarly, amounts of 5-HT and the metabolite 5-hydroxyindoleacetic acid have been found to be reduced in AD brains in a large number of other studies (e.g. Gottfries 1990; Cross *et al.* 1984).

Aetiology of Alzheimer's disease

A number of factors are thought to contribute to the cause of AD. These include genetic, environmental, transmissible and viral factors.

Genetic factors

One of the most general non-familial genetic risk factors for Alzheimer's disease and intellectual deterioration is the presence of the e4 allele of the apolipoprotein E (APOE) gene. This gene shows three common alleles, e2, e3 and e4, with e3 being observed in around 75 percent of the general population but with a much lower percentage observed (15 percent) for the e4 allele (see Figure 11.2).

Figure 11.2

The presence of the apolipoprotein e4 allele in normal, healthy individuals and in patients with Alzheimer's disease (from Teter and Finch 2004).

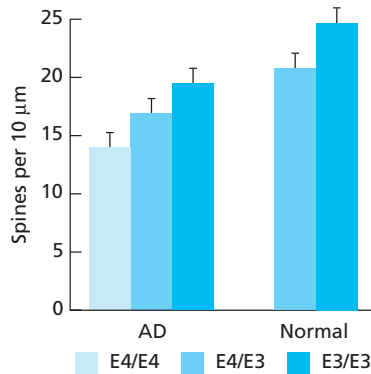

It is the e4 allele that has been associated with the neuropathological symptoms of AD, including cell death, plaques and tangles (Cedazo-Minguez and Cowburn 2001). It has been estimated that 60 percent of AD patients are e4 carriers (Mayeux *et al.* 1998), and the allele appears to increase the risk of AD twenty-fold. It has been estimated that the gene accelerates the onset of Alzheimer's disease by between five and fifteen years (Teter and Ashford 2002). One physiological effect of the alleles is to reduce neuronal sprouting. In an examination of the predictive cognitive and neuropathological effects of the presence of the e4 allele, Riley *et al.* (2000) observed the intellectual and physical development of e4 carriers at the age of 22. At that age, participants' essays showed lower 'idea density', and the allele predicted the development of AD by the time the individuals were 80 years old. In young, non-demented individuals, the presence of the allele has been associated with lower metabolism in the parietal, temporal and prefrontal cortices, the areas affected by AD (Reiman *et al.* 2004). It has also been associated with reduced visuospatial ability in people in their 40s and with reduced hippocampal volume in people in their 50s (Teter and Finch 2004). However, other studies point to a more subtle impairment. A meta-analysis of cognitive ability in around 2000 e4 carriers and 6000 non-carriers observed modest correlations between episodic recall and recognition memory and executive function in the carriers (Small *et al.* 2004). A recent investigation has also implicated the allele in impaired prospective memory (Driscoll *et al.* 2005), another type of memory that declines with age.

Transmissible agents

Transmission models suggest that AD appears because of the transfer of some agent from one organism to another. Diseases such as Creutzfeldt–Jakob disease, Gerstmann–Straussler syndrome (a familial disease) and the animal diseases scrapie (sheep and goat disease), milk encephalopathy and bovine spongiform encephalopathy (BSE) are all transmissible diseases. Neuropathological features of these diseases include spongiform brain tissue (due to vacuolation of nerve cells), tangles and plaques and, in humans, dementia. At present, however, there is no evidence for the transmission hypothesis of the aetiology of AD.

Nasal infection

Although most sensory and motor systems are not particularly affected by AD, the olfactory system is an exception. Plaques and tangles are seen in the olfactory bulb and anterior olfactory nucleus (Averback 1983) and choline acetyltransferase is reduced in the olfactory tubercles of AD patients (Simpson *et al.* 1984). It has been suggested that the toxic agent may make its way transneuronally along interconnections from the olfactory bulb to structures such as the amygdala and hippocampus, two structures that are severely affected in AD; the hippocampus is isolated from its inputs and outputs (Strange 1992). AD patients exhibit marked deficits in olfactory identification and detection (Serby *et al.* 1992), an impairment that may act as an early diagnostic marker for the disease (see the review by Duncan and Smith 1995).

It is apparent from these competing models that an understanding of the causes of AD is far from clear. It has been suggested that AD symptoms appear when a threshold of cell death is reached (Roth 1986). This threshold is reached via a brain insult (leading to cell death) or via accelerated cell death – the most likely scenario (Strange 1992). One general model of the aetiology of AD is represented in Figure 11.3.

Figure 11.3

A model for the aetiology of Alzheimer's disease (adapted from Jorm 1990)

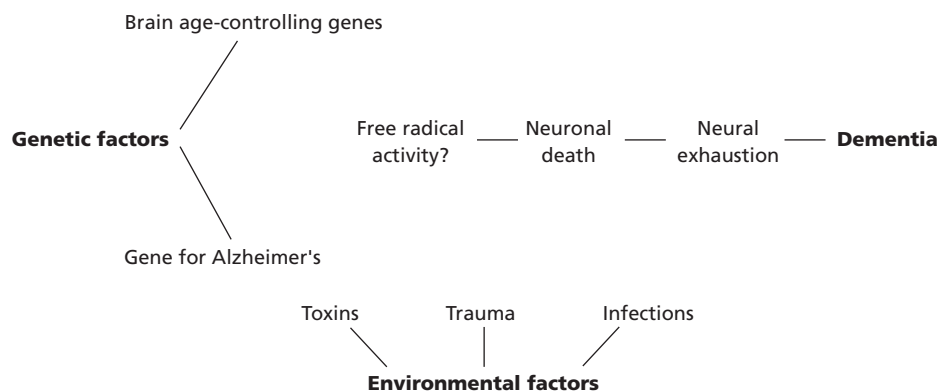

Treatment of Alzheimer's disease

Is Alzheimer's disease reversible? The current cost of caring for patients with DAT in the UK alone is estimated to be between £5 billion and £15 billion a year (McNamee *et al.* 2001; Lowin *et al.* 2001), but no current treatment is able to halt the progress of AD. Those treatments that have been attempted have focused on alleviating the disorder's memory impairments. The cholinergic hypothesis of AD led to the development of drugs that specifically sought to redress the loss of cholinergic neurons and neurotransmitters. The mechanism of action for these drugs is the inhibition of the enzyme acetylcholinesterase, which divides the neurotransmitter at its receptors (Bullock 2002). Three compounds currently used are donepezil, rivastigmine and galantamine.

Patients who have been given a course of either donepezil or rivastigmine have shown some improvement in memory performance (Cameron *et al.* 2000; Evans *et al.* 2000). Other drugs under review are anti-inflammatory drugs (because the incidence of AD is low in sufferers of rheumatoid arthritis, who take these drugs) and antioxidants such as vitamin E. However, neither has been shown to demonstrate consistent efficacy (Bullock 2002). Perhaps the most innovative treatment currently under investigation involves vaccinating the individual, thereby giving him or her an antibody to remove the amyloid protein that causes cell degeneration. Trials in mice have been effective in relieving symptoms of AD and in preventing the development of plaques (Schenk *et al.* 1999), but we have no such vaccine for humans as yet.

Preserved piano-playing in Alzheimer's disease: the case of MD

A small, but growing, literature suggests that whereas cognition, attention and memory all decline with progressive dementia, demented patients who had learned to play a musical instrument early in life show preserved playing ability. This preserved ability is thought to be attributable to preservation of right hemisphere function. However, very few longitudinal studies of cognitive decline and musical ability preservation exist.

Beatty *et al.* (1999) have reported a longitudinal study of MD, a 79-year-old New Yorker who is a pianist but suffers from probable Alzheimer's disease. They studied MD's implicit memory, left and right hemisphere function, attention, sequencing, semantic memory, musical knowledge and playing skill over three years.

At three years, there was marked impairment in every measure of cognitive ability (including tests of right hemisphere function) and semantic musical knowledge – she could not recognize familiar tunes or discriminate rhythm or metre or major from minor keys. However, her piano playing of familiar songs was only slightly impaired.

The authors suggest that the preserved ability was not attributable to a functioning right hemisphere – MD's damage was bilateral – but to a set of subcortical structures, including the motor parts of the thalamus and cortex and the basal ganglia and cerebellum. These structures are known to be some of the last to degenerate in Alzheimer's disease. Tunes learned prior to onset of the disease would utilize these intact interacting structures.

Vascular dementia

Vascular dementia is the second most common form of dementia, accounting for 15–20 percent of all cases of dementia (Mirsen and Hachinski 1988). According to the *DSM-IV*, it is characterized by:

- cognitive decline, including memory impairment (learning new information and recalling previously learned information), and one or more of aphasia, apraxia, agnosia and executive function problems;

- symptoms that cause significant decline from previous levels of functioning;
- neurological signs, including weakness in extremities, abnormal gait and exaggerated deep tendon reflexes;
- laboratory evidence of cerebrovascular disease.

Neuropathologically, the dementia can arise from ischaemia and haemorrhage or from cerebral injury caused by cardiac arrest. Multi-infarct dementia results from many small cortical and subcortical infarcts, although the reason for their appearance is unclear. Symptoms have abrupt onset and are a risk factor for vascular diseases. The term ‘multi-infarct dementia’ has been superseded by the term ‘vascular dementia’; both are used synonymously. It is more common in men than in women, and onset tends to occur after 70 years of age. Clinical features include anterograde and retrograde amnesia, general intellectual decline, evidence of cerebrovascular disease, and a fluctuating and stepwise course of symptoms. Recognition memory may be relatively spared. There is some evidence to indicate that patients with vascular dementia are slower on tests of motor and cognitive speed than are patients with Alzheimer’s disease (Almkvist *et al.* 1993), but there is no evidence of the rapid forgetting seen in DAT. Infarcts to different regions of the cortex and subcortex are associated with different cognitive symptoms. Treatment of vascular dementia is normally aimed at treating the cause, i.e. stroke. Ticlopidine appears to help to prevent cerebrovascular accident and improve the symptoms of dementia (McPherson and Cummings 1996).

Pick Complex

Pick Complex (PC) describes a collection of dementias characterized by common clinical features (Kertesz and Munoz 1998). These dementias include Pick’s disease, fronto-temporal dementia, primary progressive dementia and cortico-basal degeneration and collectively account for approximately 17–25 percent of reported dementia. This chapter will focus on the first two.

Pick’s disease is characterized by a more insidious onset than AD and an earlier, different symptomatology involving disruption in social behaviour and personality. It was first reported by Arnold Pick in 1892. The effects of the disease have an onset around late middle age, and death occurs three–twelve years following onset. There is no effective treatment.

Typically, the patient displays the ventro-medial ‘frontal lobe symptoms’ described in Chapter 5, hence the alteration in social behaviour and personality. Social disinhibition may occur, with a loss of drive as the disease progresses. This is largely attributable to frontal cortex degeneration. Temporal cortex degeneration may also occur in the later stages, although the parietal cortex is relatively unimpaired. The frontal lobe symptoms might lead to a misdiagnosis of the disorder as frontal lobe dementia and other dementias with a frontal cortex component. Histologically, however, the disease is characterized by a collection of Pick bodies intracellularly (Wechsler *et al.* 1982). Pick bodies, named after their discoverer, are argyrophilic inclusions in abnormal, balloon-shaped neural cells. There is also a proliferation of astrocytes and cell loss. These histological symptoms confirm the diagnosis of Pick’s disease.

Behaviourally, however, it is sometimes difficult to distinguish between AD and Pick’s disease because, as Pick’s disease worsens, the cognitive degeneration is similar.

Differences between the two dementias exist, however. Personality and social behaviour alterations are seen first in Pick's disease, whereas the initial symptoms of AD are cognitive and memory impairments. Also, parietal functions are impaired in AD but not in Pick's disease. If the patient exhibits the classic frontal lobe characteristics, has asymmetrical frontal or temporal atrophy but normal EEG, Pick's disease is the more likely diagnosis (Whitehouse *et al.* 1993).

Fronto-temporal lobe dementia

A separate dementia has been suggested based on frontal lobe degeneration unrelated to AD (Brun 1987). Like Pick's disease, there is temporal or frontal atrophy, but frontal lobe dementia is more common than Pick's and has distinctive features. Pick bodies are not found in this dementia (Neary and Snowden 1996). Symptoms include disorganized personality and adaptive behaviour, which precede cognitive symptoms such as deficits in planning and flexibility (executive function) and memory impairment (Sungaila and Crockett 1993). These patients are also more susceptible to interference, find maintaining sustained attention difficult (Mayes 1988), make perseverative errors, show impaired working memory, are unable to inhibit inappropriate responses, and show decreased right and left fronto-lateral activation, which is correlated with global impairment on neuropsychological tests (Elfgren *et al.* 1996). They may be hyper-religious, impulsive, compulsive and rude (Miller *et al.* 1997). Their visual and verbal recognition memory is better than that of DAT patients, and onset appears to be earlier than in AD. The disorder has been divided into dementia of the frontal type, characterized by frontal degeneration, especially the ventro-medial frontal lobe, and semantic dementia, characterized by temporal degeneration (Hodges *et al.* 1999). In the temporal variant, there is evidence of surface dyslexia, impaired semantic memory and naming deficits. However, phonological and grammatical skills are preserved, as are working memory, visuospatial function and episodic memory.

Lewy body dementia

Lewy body dementia (LBD) or diffuse Lewy body disease is characterized, neuropathologically, by the senile plaques and neurofibrillary tangles seen in Alzheimer's disease plus the presence of Lewy bodies, cytoplasmic inclusions made up of ubiquitin and neurofilament proteins. These are most commonly found in the parahippocampal cortex, cingulate cortex, neocortex, substantia nigra, locus coeruleus, nucleus basalis of Meynert and amygdala.

The neuropathological associations with Alzheimer's had led to the dementia being seen as a variant of AD (Hansen *et al.* 1990). The picture is further complicated by the similarities between the neuropsychological symptoms of AD and Lewy body dementia. Both diseases are insidious and progressive, and both are characterized by progressive

cognitive impairment and early memory loss (Salmon *et al.* 1996). This similarity had led to patients with the Lewy body variant of dementia being diagnosed as having AD. While the notion that Lewy body dementia is a distinct degenerative disorder continues to be controversial, there is evidence that the two dementias can be dissociated.

For example, unlike AD patients, those with Lewy body dementia exhibit extrapyramidal parkinsonian symptoms such as rigidity and bradykinesia, and hallucinations (Perry *et al.* 1990). Patients also present cognitive symptoms that are not normally seen in AD patients. Patients with Lewy body disease have greater impairment in fluency, concentration and visuospatial ability. They show similar onset to AD, but depression precedes cognitive decline. In a recent study, these patients were compared with AD patients and those with the Lewy body variant of AD (Galasko *et al.* 1996). Initially, all demented groups showed similar cognitive decline, with no significant group differences for attention, verbal and non-verbal episodic memory, and problem solving. However, greater parkinsonian signs and hallucinations were seen in the Lewy body groups. Furthermore, the Lewy body group performed significantly more poorly than AD patients on tests of visuospatial ability, psychomotor speed and verbal fluency. There is the possibility that the visuospatial deficit is attributable to psychomotor performance rather than visuospatial ability, however, because the nature of these tasks (copy a block, copy a cube, block design) makes demands on manual and motor functions, which are already impaired in Lewy body patients.

Parkinson's disease and Huntington's disease

These two motor disorders also result in progressive, demented symptomatology. Parkinsonian patients exhibit memory and visuospatial impairments as well as attentional difficulties. Patients with Huntington's disease have an impaired ability to maintain attention and concentration and show deficits in executive functioning. Storage and retrieval of memory are difficult, and retrograde memory is poor. Parkinson's disease was discussed in detail in Chapter 7.

Subcortical dementia

The term 'subcortical dementia' is a general term reflecting a subcortical cause of dementia. Originally, the dementia was referred to as progressive supranuclear palsy. It has symptomatology similar to Parkinson's disease, but brainstem degeneration is also involved, and its neurofibrillary tangles are short rather than paired and helical (as they are in AD). The disease shares many features with frontal lobe pathology and so may sometimes be referred to as fronto-subcortical dementia. In comparison with AD patients, those with subcortical dementia do not exhibit as severe a decline in intellectual function. For example, their recognition memory is better than those with DAT, and they can retain information better than DAT patients over long intervals (Helkala *et al.* 1988).

Alcoholic dementia

Alcoholic dementia describes a demented symptomatology resulting from chronic alcoholism and is apparent even after detoxification (Ryan and Butters 1980). Visuospatial skills are poor but not as poor as verbal skills. Memory, problem solving and concept formation may also be severely impaired, with particularly severe rapid memory loss over time (Salmon *et al.* 1993).

Korsakoff's psychosis

A distinct disorder, separate from alcoholism, is Korsakoff's psychosis or Korsakoff's syndrome (Korsakoff 1889a, b) introduced in Chapter 9. Korsakoff's psychosis is an alcohol-related organic disorder in which alcohol has been a large source of caloric intake for many years. It is a rare disorder and is caused by thiamine (vitamin B₁) deficiency. Damage to the medial diencephalon is common, especially in the dorso-medial nucleus of the thalamus and the mammillary bodies.

The first scientific description of alcohol abuse linked with amnesia was made by Lawson (1878), who described cases of severe loss of recent memory that was sometimes, but not always, associated with alcohol consumption. Korsakoff (1889a, b) reported memory loss in thirty cases of chronic alcohol abuse as well as in sixteen patients who had developed a behavioural syndrome for other reasons. In Korsakoff's syndrome, 'the memory of recent events . . . is chiefly disturbed . . . everything that happened during the illness and a short time before' (Korsakoff 1889a). Recent as well as past memories may be affected. Korsakoff noted that the severity of the deficits varied, with mild cases showing an ability to remember recent memories, if only vaguely. Patients also invented fictions and repeated them. Although different forms of brain pathology may lead to amnesic syndromes, the term 'Korsakoff's syndrome' is used to refer to cases of memory impairment that have a specific neuropathology (see below) and result from thiamine deficiency.

Clinical features

Clinical features of the dementia include an inability to encode new information and retain it in long-term memory (Ryan and Butters 1980; Butters and Cermak 1980). This impairment affects mainly declarative memory; non-declarative memory is relatively spared (Shimamura *et al.* 1987; Tulving and Schacter 1990; Frith *et al.* 1992). Recognition memory is poor, as is memory for events occurring twenty–thirty years prior to the disorder (Butters and Stuss 1989). A point of ambiguity here is whether this information had been lost or was not encoded in the first place. Information lost or unable to be retrieved includes those memories related to public events and autobiographical facts. This and the anterograde amnesia have been attributed to the development of lesions in the dorso-medial nucleus of the thalamus. Victor *et al.* (1971) found extensive atrophy of the dorso-medial nucleus in thirty-eight out of forty-three brains they studied.

Performance on span tests is relatively preserved (Kopelman 1991). Although semantic memory is intact, patients are impaired on verbal fluency tests (Kopelman 1995), digit/symbol substitution tasks (Glosser *et al.* 1977), embedded figures tests (Kapur and Butters 1977) and tasks requiring the shifting of problem-solving strategies (Oscar-Berman 1973). These impairments have been attributed to association cortex atrophy (Squire 1982).

Neuropathological features

Arendt *et al.* (1983) reported a reduction of 47 percent in the nucleus basalis of Meynert (NbM) of patients with Korsakoff's psychosis (compared with 70 percent loss in AD). No significant loss was noted for chronic alcoholics, schizophrenics or patients with Huntington's disease. Perhaps the thiamine deficiency combined with heavy alcohol consumption results in the death of cells in the NbM (Butters 1985). Support for this hypothesis comes from animal studies of thiamine deficiency, in which the nutritional deficit results in consistent damage to the dorso-medial nucleus of the thalamus (Irle and Markowitsch 1982).

Other neuropathological features include an enlargement of the third ventricle and widening of the Sylvian fissures and left frontal sulci in Korsakoff patients relative to controls (Shimamura *et al.* 1988). Chronic alcoholics had structures measuring midway between the Korsakoff patients and controls. Given that some cholinergic disruption may underlie both AD and Korsakoff's psychosis, a similar pattern of memory deficit should be seen in both. Butters *et al.* (1983) reported that although patients with Huntington's disease could use language to improve their picture-context recognition memory, AD and Korsakoff patients could not. Furthermore, AD and Korsakoff patients made more perseveration errors than did the patients with Huntington's disease. The AD and Korsakoff patients were more likely to commit intrusion errors, i.e. including detail that was not in the original passage, during the recall of a passage of prose.

There are other marked differences between the groups in terms of cognitive decline. AD patients may develop constructional apraxia in the early stage of the disease, whereas Korsakoff patients show mild to moderately severe constructional ability. There is little evidence of general language dysfunction in Korsakoff's psychosis. Although Korsakoff and AD patients may be equally poor at retrieving episodic memory (learning unrelated words), AD patients are significantly more impaired than Korsakoff patients at retrieving semantic memory (Weingartner *et al.* 1983).

Dementia associated with infection

Viral dementia

Viral infections such as *Herpes simplex* can cause severe inflammation of brain regions, damaging neurons in the hippocampus and the temporal lobe in particular. Accompanying this inflammation is a mild dementia.

Post-infectious encephalomyelitis

Patients who have suffered from measles, rubella and associated viral infections may show symptoms of dementia that are subsumed under this term. An impaired autoimmune system is thought to be responsible for the underlying neuropathology.

Human immunodeficiency virus type I encephalopathy

HIV infection is associated with gradual cognitive decline and the eventual onset of dementia. Figures vary, but between 20 and 60 percent of AIDS patients will exhibit dementia by the time they die. Encephalopathy associated with HIV appears in the later stages of AIDS and seems to be responsible for the decline in intellectual performance.

Creutzfeldt–Jakob disease

Creutzfeldt–Jakob disease (CJD) is a rare degenerative disorder affecting one individual in a million per year (Brown 1980). Clinical features of CJD include a progressive and rapid dementia. Initial symptoms are quite subtle but, once they appear, the progress of the dementia is rapid and unrelenting. The cause of the disorder is neuronal loss and vacuoles in the cytoplasm of neurons and astrocytes. According to Prusiner (1987), this spongiform encephalopathy is caused by prions (infectious particles of protein) that arise from mutations in the prion protein gene.

The neuropsychology of ageing

As the body and the brain grow older, certain changes occur. Sensory acuity declines, and the ability to move quickly is reduced. On the cognitive level, there is also a decline in various functions such as the manipulation of information in working memory, retrieval of names, reaction time, declarative memory, and information processing. These cognitive impairments – the normal deterioration seen with ageing – can be confused with the symptoms of dementia, and there is great debate over whether dementia is simply an extension of old age or a disorder that is separate from it. However, functions such as vocabulary see some improvement with age (Woodruff-Pak 1997). General IQ scores will peak at around 25 years of age and decline up to 65 years. After 65, the score drops rapidly (Woods 1994). At the most severe end of cognitive decline, there is dementia – the gradual and relentless loss in intellectual function as the individual reaches the sixth decade of life and beyond. There may be great difficulty in separating the effects of normal ageing from the effects of dementia on cognitive ability (Alzheimer's disease, for example, can only be diagnosed with certainty *post mortem*, when the brain can be examined). Data from a Canadian sample suggest that the degree of cognitive impairment that is not related to dementia is around 16.8 percent (the usual prevalence of dementia is 8 percent) (Graham *et al.* 1997).

Our categorization of individuals into age groups is fairly arbitrary. In most developed countries, the age of retirement is set at 65 (an age originally set by Count Otto von Bismark, the German chancellor from 1871 to 1890), although this does not mean that those people who are 65 or older are incapable of holding down a job or lack the cognitive and physical capacity to hold down such a job.

The process of ageing

From a strict point of view, we age as soon as we emerge from the womb. We are born with all the neurons we will have in life, and they begin to die as soon as we grow. There is a massive shedding of neurons and synapses during childhood; this continues to old age, although this shedding does not leave us intellectually helpless. Although neurons are lost, new connections are formed between existing neurons (this is why, although neurons are lost, the brain increases in weight during childhood), and the existing neurons work more efficiently. It has been suggested that psychological ageing begins after maturity and that this is measured by behaviour that includes the ability to acquire, remember and retrieve words, people and events and the ability to process and manipulate information. This scientific study of the ageing process is called gerontology.

However, one problem with studying the ageing process is the large variability between and within samples. For example, during a long period of study, older participants become susceptible to disease processes and illnesses that could directly affect the variables that gerontologists are interested in studying. This within-subject variation can also be seen in another capacity. If we take one age group, say 50–60-year-olds, and compare it with another on some cognitive measure, we are defining a group of individuals by an age category, but all individuals within this group may not show the same degree of ageing. For example, although the ability to remember strings of digits declines with age, some individuals perform badly, some stay the same and some actually get better (Holland and Rabbitt 1991). Group variation becomes more of a problem with data from cross-sectional studies, which compare independent groups on some measure. When longitudinal and cross-sectional measures are compared, the longitudinal assessments show less decline (Schaie 1990).

Other factors in ageing research that are important are an awareness that older participants become tired more quickly (Furry and Baltes 1973) and are more cautious in making decisions than are their younger counterparts (Birkhill and Schaie 1975).

Memory

There is a gradual loss in performance for certain types of memory task with age (Li *et al.* 2001). Older individuals have difficulty in retrieving names (Rabbitt *et al.* 1995) and putting names to famous faces (Burke *et al.* 1991). Those aged between 61 and 90 also show impaired verbal long-term memory, especially when there is a delay of 20 minutes and 24 hours between acquisition and free recall (Davis *et al.* 2003), as Figure 11.4 (a) and (b) shows.

Figure 11.4

(a) Verbal recall performance across four age groups after delays of 20 minutes and 24 hours; (b) recognition memory performance across four age groups after delays of 20 minutes and 24 hours (from Davis *et al.* 2003)

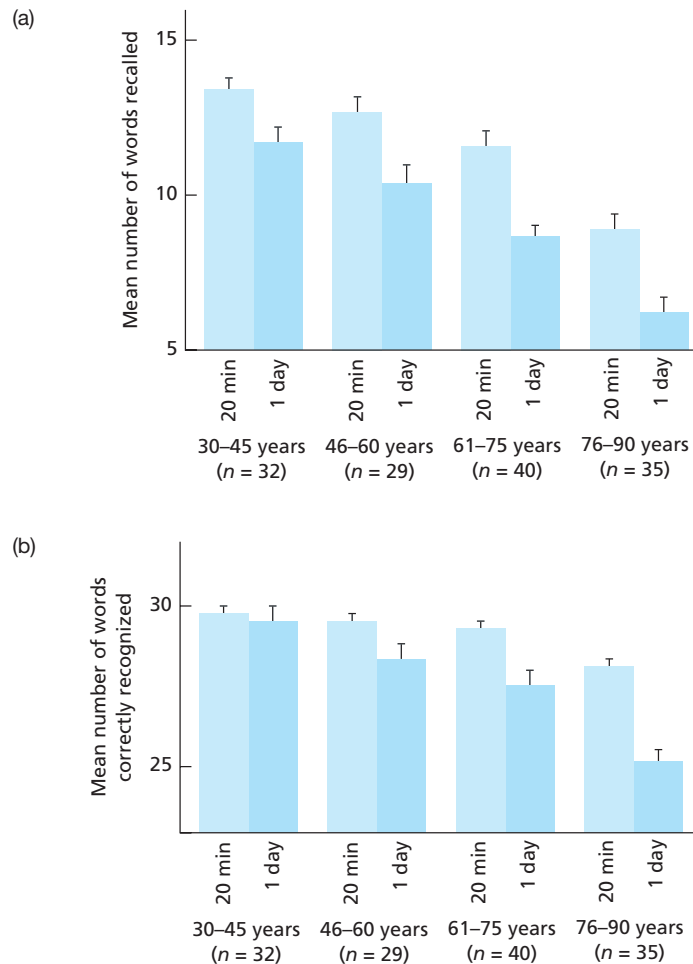

Older people also have difficulty in recalling where, when or how an event occurred, despite knowing that an event has occurred, a type of memory called source memory (Johnson *et al.* 1993). This type of memory seems more affected in the elderly than is memory for facts or items (Trott *et al.* 1997), possibly because it relies on the integrity of the frontal lobe, and the integrity of this brain region is challenged in elderly individuals, a point returned to later.

Age-related impairments have been reported for declarative memory, efficiency of processing information and metamemory (Woodruff-Pak 1997). Metamemory refers to ‘knowing about knowing’; this knowledge of skills that is necessary to complete a task may be absent in the elderly. Elderly individuals may not spend sufficient amounts of time on a task that requires time spent on it (recall of digit names in serial order, for example). When they are instructed to spend a certain length of time on this task, however, they can recall accurately just as many series of digits as younger participants.

Recent research on ageing and memory has focused on prospective memory – remembering to perform an activity in the future (Maylor 1996). This type of memory may be especially important to the elderly, given that such monitoring is essential for taking medicine at particular times (Park and Kidder 1996; Einstein *et al.* 1998). If a handkerchief or comb is borrowed by the experimenter at the beginning of a test session and/or hidden in a drawer and the individual has to remember to ask for the return of the item, there is an age-related decline in memory.

Similarly, Kliegel *et al.* (2000) found that older participants were significantly less likely to remember to initiate intended actions and had difficulties in planning, initiating and executing the set of tasks. The authors suggest that the findings may reflect superior working memory in the younger participants – the tasks required the maintenance and rehearsal of material in mind while undertaking other tasks, the critical feature of working memory and, as we have seen, a function of the frontal cortex. As the section on genetic factors in AD also showed, there is a significant correlation between the presence of the e4 allele and poor prospective memory performance.

The evidence discussed so far suggests that cognitive ability, especially certain types of memory, declines with age. But is this the case? Ritchie (1997), for example, distinguishes between behaviour that is ageing-related and age-related. Ageing-related processes are the result of ageing; age-related processes occur only at a specific age. Huntington's disease, for example, is age- not ageing-related. Is the decline seen in the elderly therefore not the result of ageing but of other age-related illnesses? Some European longitudinal data suggest that ageing may not be a factor (Ritchie *et al.* 1996; Lebovici *et al.* 1996). These researchers found that when controlling for physical illness, depression and signs of dementia, participants' cognitive performance improved over three years. They suggest that the decline that is commonly reported is due to pathology not ageing *per se*.

Processing speed and the frontal lobes

Similarly, Salthouse and colleagues (1992, 1993; Craik and Salthouse 2000) have argued that the elderly perform more poorly at cognitive tasks because they become slower at performing them. Older people have difficulty in activating, representing or maintaining information 'in mind', in attending to relevant stimuli in the environment and ignoring the irrelevant ones and in processing information speedily. Longer reaction times in the elderly are associated with reduced frontal cortex activation (Grady and Craik 2000), whereas shorter RTs are associated with increased PFC activation in the young (Grady *et al.* 1998). If individual differences in speed are partialled out of these studies, then age-related differences disappear (Salthouse and Babcock 1991). In fact, ageing could account for less than 1–2 percent of the variance seen in such studies (Salthouse 1993). This is a theory that has strong currency in gerontology. For example, several researchers have proposed that the cognitive decline seen in ageing may be attributable to reduced functioning of the frontal lobe, as the reaction time studies above suggest. The density of dopamine receptors declines in this area, and dopamine is an important neurotransmitter in the performance of working memory tasks. The volume loss in ageing appears to be greatest in the orbito-frontal cortex, caudate nucleus and putamen, but the most consistent decline has been observed in the OFC.

If there is significant frontal cortex decline with ageing, we might expect executive function, a key function of the frontal cortex, to be more significantly compromised in older participants. However, the support for this hypothesis is mixed, with some cross-sectional studies showing no differential decline, others showing decline on specific

frontal lobe tests (Crawford *et al.* 2000), and another suggesting that differences in age on executive test performance depends on two factors that such tests are thought to tap, one of which involves response shifting (Piguet *et al.* 2005). The typical asymmetrical activation in the lateral and medial prefrontal cortex in the young found during working memory task performance is less asymmetrical and more bilateral in the elderly (Reuter-Lorenz *et al.* 2000; Cabeza 2002). Similar attenuation of frontal asymmetry in the elderly has also been observed during memory encoding and retrieval (Kapur *et al.* 1996; Grady *et al.* 1995; Cabeza 2002).

However, the problem with suggesting that executive function may be specifically impaired is that executive and non-executive task performance may be difficult to distinguish in elderly samples. The reason for this is the one cited by Salthouse (1996): all of these tasks may draw on a common resource such as speed of information processing. However, the speed of processing explanation may not account for the findings from prospective memory studies. Prospective memory tasks do not rely on speed but on retention of information for future use. It is possible that timed tasks impair the ability of the elderly. This was evident in experiments where participants could name famous faces if given enough time.

An alternative (or complementary) view to the frontal lobe hypothesis suggests that ageing results in an impairment of cognitive differentiation – the degree to which behaviour is specialized for specific tasks. The decline, which is domain-independent, is reflected in neurons' inability to perform such differentiation. The cortical basis of visual differentiation may be the ventral visual cortex; this responds to faces, orthography and places – and shows less atrophy than other areas with age. In an fMRI study where 12-year-olds and 70-year-olds were asked to view faces, houses, pseudowords and chairs, less specialization in activation in the ventral visual cortex was found in the elderly sample (Park *et al.* 2004), as Figure 11.5 shows. Given that perceptual processing speed declines with age, perhaps such a slowness might be the result of a ventral visual cortex that shows less differentiation. Because there is less differentiation, older participants who are asked to make same/different decisions about geometric pairs or digits (a standard perceptual processing speed task) are slower at doing so.

Figure 11.5

The dedifferentiation scores of young and old participants in Park *et al.*'s (2004) study. The higher the bar, the greater the dedifferentiation (from Park *et al.* 2004. © 2004 National Academy of Sciences, USA)

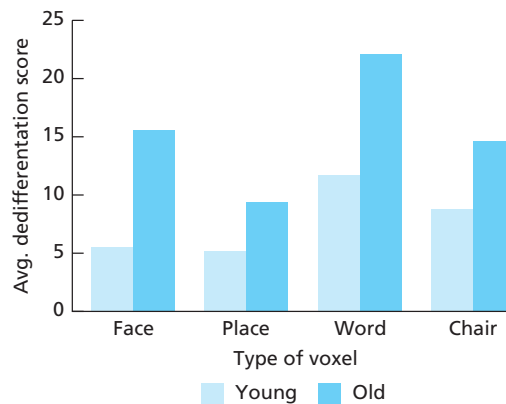

Discussion point: are the neuropsychological effects of ageing different to those of dementia?

The symptoms of dementia of the Alzheimer type (DAT) can pose problems for diagnosticians, because the ageing population also exhibits deficits in some aspects of cognitive functioning as well as showing degeneration of some parts of the brain. It might be useful, therefore, to find a way to more clearly describe the differences between the effects of normal ageing and the effects of dementia.

By the time individuals reach 70 years of age, it has been estimated that brain volume is 6 percent less than that of younger adults (Haug and Eggers 1991). This reduction is greatest in the frontal cortex (10–17 percent loss) and striatum (8 percent loss). The characteristic of this reduction appears to be a shrinkage in neuron size rather than a loss of actual neurons. Again, this reduction in size is more apparent in the prefrontal cortex (West 1996). Some researchers have argued that neurons degenerate with age, that dendritic processes and spines become fewer and synaptic density declines, making the functioning of cell bodies ineffective (Duan *et al.* 2003; Jacobs *et al.* 1997). As a result, the number of synapses, receptor sites and amounts of neurotransmitters present in the brain declines (Hof and Morrison 2004). Perhaps of greater relevance to dementia is the presence of senile plaques in the ageing brain (Kubanis and Zornetzer 1981). These are greatest in the temporal and frontal cortex, which contrasts with the main sites affected in Alzheimer's disease, which are the hippocampus, locus coeruleus and nucleus basalis and association cortices (Horvath and Davis 1990). However, the excess amyloid appears to be a poor correlate of cognitive impairment – the presence of neurofibrillary tangles is the factor that correlates more highly with decline (Teter and Finch 2004). By middle age, there is evidence of tangles in the parahippocampal gyrus, but little or no evidence of amyloid (Braak and Braak 1991).

Further neurophysiological changes with ageing are found in rCBF studies. These show that the brain's use of oxygen, as measured by rCBF, declines by up to 27 percent in some areas in ageing individuals (Melamed *et al.* 1980). Whereas hyperfrontality (increase in frontal rCBF) is characteristic of young and middle-aged individuals, hypofrontality (decline in frontal rCBF) is characteristic of older individuals. It is strange to note that although these changes are seen when the individual is resting, few changes are seen between age groups when individuals perform particular arithmetical, verbal and visuospatial tasks (Gur *et al.* 1987).

Strange, because decline in cognition is probably the most obvious psychological characteristic of ageing. This said, one study has compared young participants' (26 years old on average) and old subjects' (70 years on average) brain activation during the encoding, recognition and recall of word pairs (Cabeza *et al.* 1997). It was found that during encoding, young subjects showed greater activation than did the old participants in the left prefrontal and occipito-temporal region, whereas they showed greater right prefrontal and parietal activation during retrieval. In old subjects, there was greater activation in the insula during encoding, the cuneus and precuneus during recognition and the left prefrontal region during recall. Although young subjects showed left frontal activation during encoding and right activation during recall, old subjects showed little frontal activation during encoding and more bilateral activation during recall. The authors suggest that what is happening is the inefficient processing of stimuli, as evidenced by decreases in activation, and overcompensation for this inefficiency, as evidenced by age-related increases in activation.

The focus on memory is important, because its impairment may be confused with the symptoms of DAT. There appears to be no decline in sensory memory, short-term memory and remote memory in the elderly, but recall and recognition in long-term memory are significantly impaired (Poon 1985; Light 1991). This decline is illustrated in Figure 11.6. The dissociation between deficits on tests of explicit and implicit memory provides further evidence for a multiple systems model of human memory, as discussed in Chapter 9.

Specific deficits have been found in the ability to recall words that were previously presented (Davis *et al.* 1990). In Davis *et al.*'s study, the over-50s recalled significantly fewer words than did individuals in their 40s or younger. When there was a delay between presentation and recall of stimuli, the over-50s were significantly poorer than they were when recall was immediate. Deficits are also seen on tasks in which individuals have to acquire cognitive skill. For example, with practice, most individuals can learn to complete the Tower of Hanoi task. This task is similar to the Tower of London task described in Chapter 5. In this exercise, individuals must move a series of differently sized rings from one peg to another so that the second set of pegs remains in the same order as the first. Only one ring can be moved at a time, and a larger ring cannot be placed on a smaller one. The minimum number of moves necessary to complete the task successfully is $2^n - 1$, where n is the number of rings. Older individuals perform significantly more poorly on this task than do the under-40s (Davis and Bernstein 1992). Individuals in their 70s and 80s make significantly more moves than do those in their 20s and 40s.

Figure 11.6

Memory test scores for three age groups (from Rabbitt 1993)

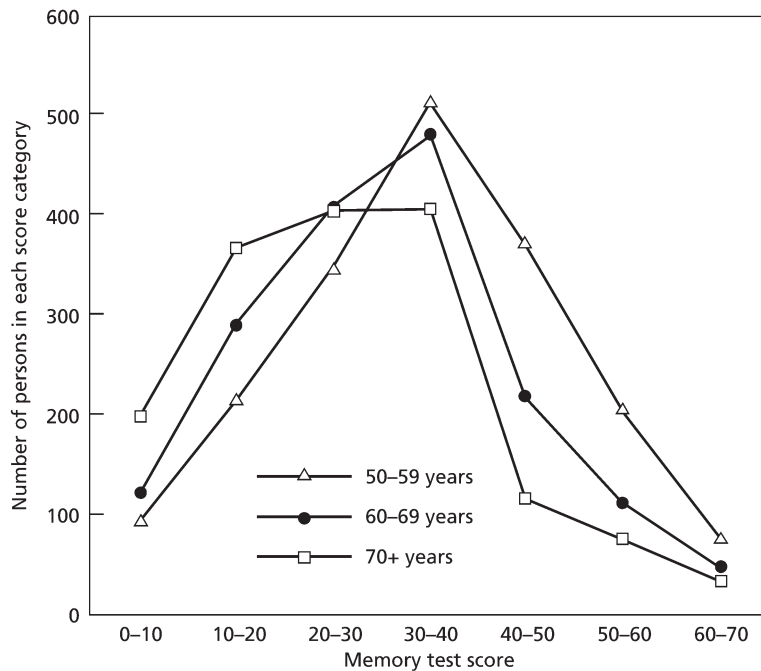

However, not all tasks show a decline with ageing. Vocabulary, for example, appears to be quite resistant to the effects of advancing age (Rabbitt 1993), as seen in Figure 11.7. According to Horn and Cattell (1967), this preservation is due to the fact that vocabulary requires the constant acquisition and continued use of information and is an example of crystallized intelligence, which is stable. Tests on which elderly individuals perform poorly are characteristic of fluid intelligence, which declines with age. The correlation between vocabulary scores and scores on other cognitive tests tends to decline with age.

Are these functional and neural deficits seen in both degenerating and ageing brains related? It is known that temporal, parietal and frontal degeneration, especially the association cortices, occurs in AD. The types of deficit seen in AD might result from parietal and temporal association cortex degeneration, because these regions integrate sensory information from several modalities. Furthermore, the cognitive and memorial decline seen in AD can be related to the loss of cholinergic cells innervating the cortex and hippocampus. Anticholinergic drugs such as scopolamine bring about deficits in short-term memory in humans; disruption of cholinergic pathways in animals results in deficits in memory tests. Perhaps the cholinergic pathways and their connections allow the formation and retention of new memories.

What is obvious is that the relationships between normal ageing and Alzheimer's disease, and cognitive and neural decline, are complex. However, there do appear to be cognitive dissociations between normal and clinical degeneration.

Figure 11.7

Vocabulary scores for three age groups (from Rabbitt 1993)

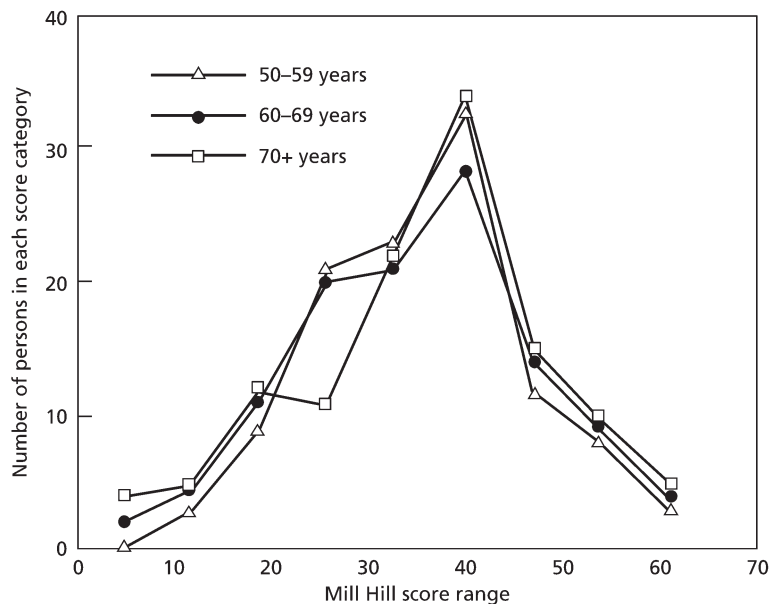

Summary

Dementia is a term used to describe a gradual and insidious decline in cognitive function. The diagnosis is complicated by the cognitive decline that occurs during normal ageing. A diagnosis of dementia requires the patient to exhibit impairment in short- and long-term memory, memory/cognitive impairment that interferes with work, social activities and relationships, and at least one of the following: abstract thinking impairment, impaired judgement, higher cortical function disturbance (aphasia, apraxia, agnosia) or personality change. Alzheimer's disease (AD) is the commonest cause of dementia, and dementia of the Alzheimer type (DAT) is the commonest form of dementia, occurring in approximately 45 percent of demented patients. There is a familial form of Alzheimer's disease that is autosomal dominant. The gene is thought to be carried on chromosome 21. There is evidence of shrinkage of the frontal and temporal gyri in AD, and there is neuronal loss from the cortex, hippocampus, amygdala, basal forebrain, locus coeruleus, raphe nuclei and nucleus basalis of Meynert. PET studies indicate parietal and temporal lobe abnormalities. The hallmark characteristics of AD are neurofibrillary tangles, senile plaques, granulovacuolar degeneration and Hirano bodies in various parts of the brain. Other major causes of dementia include Pick's disease, frontal lobe dysfunction, diffuse Lewy body disease, Parkinson's disease, Huntington's disease, subcortical dysfunction, alcoholism, Korsakoff's psychosis, cerebrovascular accident, infection, Creutzfeldt–Jakob disease and various neurological complaints. Vascular dementia is the second most common form of dementia and results from some cerebrovascular accident. One example is multi-infarct dementia, which is characterized by anterograde and retrograde amnesia and a fluctuating course of symptoms. Ageing is accompanied by many changes in neurophysiology and cognition, including a reduction in the size of neurons, especially in the prefrontal cortex, a decline in the brain's oxygen use and an impairment in explicit memory. The brain areas affected in ageing appear to be different from those affected in AD.

Recommended further reading

Dementia of the Alzheimer type

- Done, D.J. and Hajilou, B.B. (2005). Loss of high-level perceptual knowledge of object structure in DAT. *Neuropsychologia*, 43, 60–8.
- Dopkins, S., Kovner, R., Rich, J.B. and Brandt, J. (1997). Access to information about famous individuals in Alzheimer's disease. *Cortex*, 33, 333–39.
- Fleischman, D.A. and Gabrieli, J.D.E. (1999). Long-term memory in Alzheimer's disease. *Current Opinion in Neurobiology*, 9, 240–44.
- Fox, N.C., Warrington, E.K., Seiffer, A.L., Agnew, S.K. and Rosser, M.N. (1998). Presymptomatic cognitive deficits in individuals at risk of familial Alzheimer's disease. *Brain*, 121, 1631–39.
- Gerrard, P., Maloney, L.M., Hodges, J.R. and Patterson, K. (2005). The effects of very early Alzheimer's disease on the characteristics of writing by a renowned author. *Brain*, 128, 250–60.
- Greene, J.D.W. and Hodges, J.R. (1996). Identification of famous faces and famous names in early Alzheimer's disease. *Brain*, 119, 111–28.
- Greene, J.D.W. and Hodges, J.R. (1996). The fractionation of remote memory. *Brain*, 119, 129–42.
- Hall, K.S., Gao, S.J., Unverzagt, F.W. and Hendrie, H.C. (2000). Low education and childhood rural residence – risk for Alzheimer's disease in African-Americans. *Neurology*, 54, 95–9.

- Iqbal, K., Sisodia, S.S. and Winblad, B. (2001). *Alzheimer's Disease: Advances in Etiology, Pathogenesis and Therapeutics*. Chichester, UK: John Wiley & Sons.
- Meiran, N. and Jelicic, M. (1995). Implicit memory in Alzheimer's disease: A meta-analysis. *Neuropsychology*, 9, 291–303.
- Mendez, M.F., Cherrier, M.M. and Perryman, K.M. (1997). Differences between Alzheimer's disease and vascular dementia on information processing measures. *Brain and Cognition*, 34, 301–10.
- Moayeri, S.E., Cahill, L., Jin, Y. and Potkin, S.G. (2000). Relative sparing of emotionally influenced memory in Alzheimer's disease. *Neuroreport*, 11, 653–5.
- Morris, R. and Becker, J. (2004). *Cognitive Neuropsychology of Alzheimer's Disease*. Oxford: Oxford University Press.
- Rasmusson, D.X., Carson, K.A., Brookmeyer, R., Kawas, C. and Brandt, J. (1996). Predicting rate of cognitive decline in probable Alzheimer's disease. *Brain and Cognition*, 31, 133–47.
- Snowden, J.S., Thompson, J.C. and Neary, D. (2004). Knowledge of famous faces and names in semantic dementia. *Brain*, 127, 860–72.

Other dementias

- British Journal of Psychiatry* (2002). vol. 180. Special issue on treatment approaches to dementia.
- Darvesh, S. and Freedman, M. (1996). Subcortical dementia: a neurobehavioural approach. *Brain and Cognition*, 31, 230–49.
- Everitt, B.J. and Robbins, T.W. (1997). Central cholinergic systems and cognition. *Annual Review of Psychology*, 48, 649–84.
- Kopelman, M.D. (1995). The Korsakoff syndrome. *British Journal of Psychiatry*, 166, 154–73.
- McPherson, S. and Cummings, J.L. (1996). Neuropsychological aspects of vascular dementia. *Brain and Cognition*, 31, 269–82.
- Mummery, C.J., Patterson, K., Wise, R.S.J., Price, C.J. and Hodges, J.R. (1999). Disrupted temporal lobe connections in semantic dementia. *Brain*, 122, 61–73.
- Neary, D. and Snowden, J. (1996). Fronto-temporal dementia: nosology, neuropsychology, and neuropathology. *Brain and Cognition*, 31, 176–87.
- Paller, K.A., Acharya, A., Richardson, B.C., Plaisant, O., Shimamura, A.P., Reed, B.R. and Jagust, W.J. (1997). Functional neuroimaging of cortical dysfunction in alcoholic Korsakoff's syndrome. *Journal of Cognitive Neuroscience*, 9, 2, 277–93.

Ageing

- Boller, F. and Cappa, S. (2001). *Aging and Dementia*. New York: Elsevier Science.
- Cabeza, R., Nyberg, L. and Park, D. (2004). *Cognitive Neuroscience of Aging*. Oxford: Oxford University Press.
- Craik, F.I.M. and Salthouse, T.A. (2000). *The Handbook of Aging and Cognition*. London: Lawrence Erlbaum.
- Cummings, J.L. (2003). *The Neuropsychology of Alzheimer's Disease and Other Dementias*. Hove, UK: Psychology Press.
- Grady, C.L. (2000). Functional brain imaging and age-related changes in cognition. *Biological Psychology*, 54, 259–81.
- Hof, P.R. and Morrison, J.H. (2004). The aging brain: morphomolecular senescence of cortical circuits. *Trends in Neurosciences*, 27, 607–13.
- Kramer, A.F. and Willis, S.K. (2003). Cognitive plasticity and aging. *The Psychology of Learning and Motivation*, vol. 43, 267–302.
- Li, S.-C., Lindenberger, U. and Sikstrom, S. (2001). Aging cognition: from neuromodulation to representation. *Trends in Cognitive Sciences*, 5, 11, 479–86.

- Morris, R.G. (2004). Neuropsychology of older adults. In L.H. Goldstein and J.E. McNeil (eds), *Clinical Neuropsychology: A Practical Guide to Assessment and Management for Clinicians*. Chichester, UK: John Wiley & Sons.
- Naveh-Benjamin, M., Moscovitch, M. and Roediger, H.L. (2002). *Perspectives on Human Memory and Cognitive Aging*. Hove, UK: Psychology Press.
- Park, D.C., Polk, T.A., Park, R., Minear, M., Savage, A. and Smith, M.R. (2004). Aging reduces neural specialization in ventral visual cortex. *PNAS*, 101, 35, 13091–5.
- Rabbitt, P. (2005). Cognitive gerontology: cognitive change in old age. Special issue of *Quarterly Journal of Experimental Psychology Section A*. Hove, UK: Psychology Press.
- Sachdev, P.S. (2003). *The Ageing Brain*. Hove, UK: Psychology Press.
- Special issue of *Trends in Neurosciences* (2004). Vol. 27 on 'Ageing and dementia'.
- Tisserand, D.J. and Jolles, J. (2003). On the involvement of prefrontal networks in cognitive ageing. *Cortex*, 39, 4/5, 1107–28.
- West, R.L. (1996). An application of prefrontal cortex function theory to cognitive aging. *Psychological Bulletin*, 120, 2, 272–92.

12 Disorders of thought and mood

- Introduction
- Schizophrenia
 - Subtypes of schizophrenia
 - Cognitive deficits
 - Genetics and schizophrenia
 - Abnormalities in brain structure
 - Abnormalities in brain activation
 - Neurotransmitter abnormalities
- Epilepsy
 - Generalized epilepsy
 - Partial (focal) epilepsies
 - Cognitive impairment in epilepsy
- Disorders of mood
 - Depression: a description
 - Anxiety: a description
- Summary
- Recommended further reading

Introduction

In the previous chapters, the consequences of brain injury on cognition were described and evaluated in the context of general neuropsychology: could these injuries and their consequences tell us anything about the way in which the brain organizes cognition and how we think and behave? The chapters also described some of the attempts at localizing such functions in the healthy brain. Chapters 5 and 10 further extended the study of cognition to studies of emotion, social behaviour and personality.

Although many of the neuropsychological disorders considered so far are just that – disorders of cognition, perception and movement– there are disorders that are not neuropsychological in purist terms (in the sense that brain injury has caused a functional impairment) but can reveal how the dysfunctional brain gives rise to abnormalities in thought and mood. The most common of these disorders are schizophrenia, depression and anxiety, conditions conventionally classed as mental illness (although many of the disorders described in this book also appear in the *DSM-IV*). This chapter examines the symptoms, causes and neuropsychological features of these disorders.

Schizophrenia

One of the more misunderstood of the psychiatric disorders, the term ‘schizophrenia’ was originally coined by Eugen Bleuler in 1911 to suggest a fractionation of the mind: ‘schizo’ is Greek for ‘to split’ and ‘phren’ Greek for what we would call ‘mind’ or ‘intellect’. Bleuler regarded the disorder (in fact, he identified two types – reactive and process) as a break in individuals’ connection with reality caused by such mental disorganization that thoughts and emotions did not appear normal. Nowadays, our definition is a little more precise, but there is still controversy over whether the disorder is unitary and whether its fractionated types constitute real, disparate disorders.

Schizophrenia is the most common psychotic disorder and is made up of several types. Its most common symptoms are a distortion in thought, perception and emotion, and bizarre behaviour. Social withdrawal and occupational dysfunction are also features.

The disorder does not respect cultural, national or educational boundaries: schizophrenia has been subject to three major cross-cultural studies over twenty-five years in twenty research centres in seventeen countries (Jablensky 1989). The 1979 study conducted by the World Health Organization (1979) found that the prognosis (outcome) for schizophrenia was better in developing countries (Colombia, Nigeria, India) than in developed countries (USA, UK, Denmark). Schizophrenia was diagnosed as being more chronic in the most well-educated people, but only in developing countries. Later studies indicated that the outcome for schizophrenia was worse in countries such as India. One of the most comprehensive cross-cultural studies examined 1,379 schizophrenics in twelve centres from ten countries. In each of the countries studied, the incidence rates were comparable (Jablensky *et al.* 1992).

The lifecourse of the disorder is chronic – that is, prognosis is not good (Carpenter and Buchanan 1994). Onset can be abrupt or gradual, but the disorder is usually preceded by escalating symptoms. This period is called the prodromal phase (Lieberman *et al.* 2001). Recovery is relatively poor – around 20–30 percent lead normal lives (such as living independently and holding down a job), but most experience debilitating effects throughout adulthood. Between 20 and 30 percent experience moderate symptoms, with approximately 50 percent of those diagnosed experiencing significant impairment (Cancro 1989).

According to the *DSM-IV*, a diagnosis of schizophrenia depends on the presence of two or more symptoms for a period of more than six months. These symptoms are hallucinations, delusions, disorganized speech, disorganized behaviour, catatonic behaviour, negative symptoms and flattened affect. Only one of these symptoms needs to be present if the individual’s delusions are bizarre or the hallucinations are auditory and involve a running commentary on the person’s behaviour or a conversation between two voices. Social and occupational dysfunction must also be present, along with the two classic symptoms.

Delusions, hallucinations and thought disorder are described as the schizophrenia’s positive symptoms. Delusions are beliefs that are contrary to reality and can involve delusions of persecution (the belief that others are plotting and conspiring against them), grandeur (overblown belief in one’s own importance, i.e., believing one is God) and control (the belief that the individual is being controlled by others). Thought disorder – characterized by disorganized speech, thought and behaviour – is the disorder’s most pronounced feature. Logical thinking is difficult, and patients will jump from one topic of conversation to another, utter meaningless words or choose words that rhyme rather than words that convey meaning. Hallucinations can be auditory (the most common), visual or in any other modality and are perceptions of stimuli that are not present. A typical hallu-

ination involves voices talking to the person, sometimes ordering the person to act or providing a running commentary on their behaviour. The negative symptoms are characterized by the absence of normal behaviour (rather than the appearance of an abnormal type): these include a flattening of affect, reduced speech, a lack of initiative, the inability to experience pleasure, and social withdrawal.

Obstetric complications (such as labour and delivery complications) have been suggested as one cause of the disorder: the likelihood of schizophrenia developing has been found to increase linearly with increasing obstetric complications (McNeil *et al.* 2000). The disorder may possibly be due to the hypoxia caused by some complications, which results in brain injury.

Children who are pre-schizophrenic have been found to be less responsive and more socially withdrawn, have poorer social adjustment and show less emotion than their non-schizophrenic counterparts (Walker and Lewine 1990). When the home movies of children with schizophrenia were studied, these children showed more negative facial expressions of emotion than their siblings. Graduates who observed the tapes without knowing whether the subjects were schizophrenic or not, were easily able to differentiate the schizophrenic from the non-schizophrenic (Walker *et al.* 1993). Motor functions can be delayed or abnormal in these children and may show impairments in the motor milestones, such as using two hands to manipulate objects and walking (Walker *et al.* 1994).

Subtypes of schizophrenia

There are four subtypes of schizophrenia: paranoid, disorganized, catatonic and undifferentiated.

1. *Catatonic subtype*: this is characterized by motor disturbance such as the adoption of catatonic postures – the individual maintains bizarre, statuesque postures for hours – and waxy flexibility, where the individual's limb can be repositioned without resistance and is maintained. Individuals may also be mute or repeat back what they have just heard (echolalia).
2. *Paranoid subtype*: this is characterized by the delusions of persecution, grandeur and control, so the behaviour can reflect a belief not only that they are being observed but also that they are being controlled or that they have omnipotent abilities. Hallucinations are also a feature, but there is no flattened affect, disorganized speech or catatonic behaviour. This type has the best prognosis.
3. *Disorganized subtype*: this is identifiable as a progressive disorder of thought with disorganized speech and inappropriate emotional behaviour. This type has the worst prognosis.
4. *Undifferentiated subtype*: this comprises symptoms that can include hallucinations, delusions and disorganized speech, but the patient does not meet the criteria for the first three types.

Two other diagnostic categories are also used: residual type and schizophreniform type. The former refers to an individual who may have experienced schizophrenic symptoms in the past but no longer does (although there may be residual negative symptoms). The latter describes a type that is almost full-blown schizophrenia but has not yet met the six-month minimum period for the experience of symptoms.

Cognitive deficits

Cognition is almost universally impaired in schizophrenia: schizophrenic patients have reduced response times (Krieger *et al.* 2001); impairments in verbal and spatial memory, reasoning and planning (Kuperberg and Heckers 2000); difficulties in ascribing an emotion to a person's facial expression (Penn and Combs 2000); and deficits in comprehending or solving social problems (Penn *et al.* 1997).

Patients also appear to be slower than healthy individuals in the initial processing of visual information, a finding that has been correlated with decreased thalamic, prefrontal cortex and parietal cortex activation in unmedicated schizophrenics (Braus *et al.* 2002). Another feature that seems to distinguish schizophrenics from non-schizophrenics is 'prepulse inhibition'. When we encounter an unexpected stimulus (e.g. a gust of air to the eyeball), we produce a startle response (in this case, an eyeblink). However, if this unexpected stimulus is preceded by another that is weak and not startling, the startle response is inhibited; this is called prepulse inhibition. Schizophrenic individuals do not show this attenuation of the startle response (Perry *et al.* 2002). Some of these deficits may have neuroanatomical correlates, as the sections below discuss.

Genetics and schizophrenia

Before discussing the possible neurobiological basis of schizophrenia, it is essential to consider the role of genetic defects in the appearance of the disorder. Twin studies of schizophrenia have measured the concordance rates for schizophrenia of identical or monozygotic twins (those fertilized from the same egg) and fraternal or dizygotic twins (fertilized from different eggs). The concordance rate is the likelihood that two groups will develop the same disorder. This has been reported to be 50 percent in monozygotic twins and 20 percent in dizygotic twins (Gottesman and Shields 1982; Gottesman 1991), which suggests some link to heritability but perhaps an important link to environment or some other factor (the concordance rate for monozygotic twins is not 100 percent, for example).

The most promising genetic candidates for schizophrenia have been the serotonin type 2a receptor (5-HT_{2a}) gene and the dopamine D₃ receptor gene. Regions of chromosomes 6, 8, 13 and 22 have also been suggested (Badner and Gershon 2002), as has 22q11 deletion. This type of chromosomal deletion occurs in a minute percentage of the population and specifically manifests itself as a deletion on chromosome 22q11.2. The typical characteristics are facial, head and heart anomalies, but the deletion has been associated with adult schizophrenia, with up to 25 percent of a sample of schizophrenics showing the deletion (Karayiorgou *et al.* 1995; Bassett *et al.* 1998). There is also evidence of an overlap between those genes contributing to schizophrenia-like disorders and mania (Cardno *et al.* 2002), suggesting that genetic vulnerability may be a disposition to psychosis in general rather than to schizophrenia specifically.

Abnormalities in brain structure

In terms of structure, there seems to be a significant reduction in frontal, temporal and whole brain volume when schizophrenic brains are compared with controls, as well as a decrease in the size of various subcortical structures such as the thalamus and hippocampus (Lawrie and Abukumeil 1998; Schmajuk 2001). The hippocampus, in particular, seems to be the most consistently smaller.

Longitudinal studies of schizophrenia have found that schizophrenics show decreased grey matter and increased ventricle size in the early stages of the illness and during adolescence – more so than the decline in grey matter normally seen in adolescents (Cahn *et al.* 2002). Cortical and hippocampal volume also appear to decrease, and these abnormalities may precede the appearance of the cognitive and behavioural symptoms of the illness (Giedd *et al.* 1999). Prodromal symptoms are associated with reduced grey matter in various areas, including the left parahippocampal gyrus, the orbito-frontal cortex, the cerebellum and the cingulate gyrus (Pantelis *et al.* 2003).

Abnormalities in brain activation

PET and fMRI studies have shown that the areas most often associated with decreased metabolism are the frontal and temporal cortices (Kinderman *et al.* 1997; Pae *et al.* 2004). The frontal and temporal dysfunctions usually occur in the form of hypofrontality, i.e. a decrease in activity. Some researchers have suggested that this pattern of reduced activity is not consistent and suggest that the drugs taken by schizophrenics may be responsible for the reduction (Gur and Gur 1995). To test this hypothesis, Andreasen *et al.* (1997) neuroimaged seventeen neuroleptically naive (i.e. ‘drug-free’) patients during the early stages of the illness. They reported that there were decreases in the lateral, orbital and medial areas of the frontal cortex and the regions connected to those regions. The evidence for a reduction in activation is therefore persuasive.

PET studies also suggest that there is a decrease in dopamine receptors in the prefrontal cortex (Okubo *et al.* 1997). There is also evidence that neuronal density in the prefrontal cortex is 17 percent higher compared with patients with Huntington’s disease and patients with schizophrenia-related disorders (Selemon *et al.* 1995). These researchers suggested that this ‘squashing’ of neurons results from abnormal brain development and may account for the frontal lobe deficits. The involvement of the frontal lobe is also suggested by studies of working memory in schizophrenics. Keefe *et al.* (1995) have found that schizophrenic patients perform poorly at keeping information in working memory over 30- and 60-second delay periods.

However, others have suggested that the important brain abnormality is the connection between the temporal and frontal regions (Frith 1992). These conclusions are based on evidence such as that obtained from twenty-nine schizophrenic patients who completed a battery of neuropsychological tests (Bilder *et al.* 1995). In this study, those tests thought to tap frontal or motor function were correlated with activity in the anterior hippocampal region only. Neuroimaging work by Frith and his colleagues has also implicated limbic and sublimbic activation in schizophrenics during auditory verbal hallucination (Silbersweig *et al.* 1995; McGuire *et al.* 1996; McGuire *et al.* 1998). The evidence therefore indicates some role for the frontal and temporal cortices in schizophrenia, but the relevance of the structures is currently unclear.

Crow (1998, 2002), for example, has controversially suggested that a deficit in the functional lateralization of the brain, especially the lateralization of language, may be the cause of schizophrenia, although the evidence for this is mixed. A recent study found a significant reduction in the superior (top) part of the left temporal lobe in schizophrenic patients as well as a general reduction in the size of the temporal lobe, although this last finding was not statistically significant (Highley *et al.* 1999). The researchers also found a relationship between this asymmetrical reduction and the time of onset of the disorder: the later the onset, the greater the reduction. Another study, this time of frontal lobe asymmetry, found that the planum temporale and Sylvian fissure were less lateralized in

schizophrenic patients (Sommer *et al.* 2001). However, a study of the volume of the amygdala at *post mortem* found no significant difference in size between a schizophrenic and control group (Chance *et al.* 2002).

Neurotransmitter abnormalities

Cocaine and amphetamine both produce symptoms very similar to schizophrenia, and both affect neural pathways that release dopamine. Antipsychotic medication reduces schizophrenic symptoms and is correlated with decreased dopamine levels (Carlsson 1988). Antipsychotic drugs act by blocking dopamine receptors, especially the D2 receptor subtype. Chlorpromazine and other antipsychotic drugs are remarkably effective in alleviating the positive symptoms of schizophrenia, such as delusions and hallucinations, but they produce little consistent improvement in the negative symptoms. Later drugs, called 'atypical' or 'second-generation' neuroleptics (such as clozapine), also act on dopamine receptors but may be more specific in the receptor types they occupy. Clozapine is the recommended drug for those patients who are treatment-resistant. It does have serious side-effects, however, and requires the patient to have regular blood tests, because the drug can cause a reduction in white blood cells (which can be fatal).

Drugs such as amphetamine and cocaine cause the stimulation of receptors for dopamine. In contrast, antipsychotic drugs block dopamine receptors and prevent them from becoming stimulated. The focus of the drugs appears to be the D2 receptor in the striatum: around 70 percent of these receptors are occupied by antipsychotic medication, which blocks their action (Lidow *et al.* 1998). Cocaine, conversely, activates this receptor. The number of D2 receptors seems to be higher in the brains of schizophrenic individuals (Kestler *et al.* 2001). Other neurotransmitters that may play a role in schizophrenia are glutamate and its subtype, NMDA. Glutamatergic receptors, which are excitatory, may be less active in schizophrenia (Tsai and Coyle 2000). GABA is an inhibitory neurotransmitter whose release is also abnormal in schizophrenia, so perhaps its inhibitory effects are increased in schizophrenia.

Epilepsy

As defined by Gastaut (1973), epilepsy is a 'chronic brain disorder of various aetiologies characterised by recurrent seizures due to excessive discharge of cerebral neurons' (p. 8). There are various types and, depending on age, divergently different causes. However, the primary symptoms of any type of epilepsy are seizures and excessive discharges of neurons.

A seizure is a single and sudden event caused by these discharges (Lee 2004). The discharges can produce changes in sensation, consciousness, cognition and convulsions, and physical symptoms can vary depending on the focus and location of the discharge; a focus in the postcentral gyrus, for example, will produce somatosensory sensations such as tingling or numbness in the tongue or lips (Lee 2004).

The possible causes of epilepsy vary depending on whether the patient is a child, an adult or an old adult. However, there is one simple fact regarding the aetiology of the disorder: it is largely idiopathic, i.e. there is no known cause. In children, the most common precipitating factors are injuries sustained during birth, anoxia, infection and trauma. In adults over 60, these factors are vascular disease, tumour and degenerative disease. The

development of epilepsy between these two epochs is unusual – around two-thirds of seizures begin in childhood, and most begin in the first year of life, with the incidence picking up again in the elderly (Lee 2004). Head injury has been associated with the appearance of the disorder – there is a 1 percent chance of developing the disorder in the first five years following mild head injury, 10 percent with severe head injury (Annegers *et al.* 1980).

Epilepsy is classified into two general types based on the symptoms that individuals present and their EEG activity: generalized epilepsy describes a condition where seizures seen in an EEG are bilateral; partial epilepsy describes a condition where the focus of the discharge is more specific.

Generalized epilepsy

This type of epilepsy occurs in around 37 percent of sufferers, and its most common forms are tonic–clonic (or *grand mal*) epilepsy and absence (or *petit mal*) epilepsy.

Generalized tonic–clonic type

This epilepsy is named after the two periods of muscle activity that occur during the seizure (the period during the seizure is called the ictus phase). During the tonic phase, tonic contractions of multiple muscles occurs – the individual’s back may be arched and his/her arms or legs extended. Breathing may be laboured, and the phase lasts about 10–20 seconds. During the clonic phase, the muscles of the whole body repeatedly contract. This activity alternates with periods of sudden relaxation. This phase can last between 30 and 60 seconds. Following this phase, the individual enters the post-ictal period of the seizure, where they may not be responsive to any stimulus and may fall asleep. A seizure of the tonic–clonic type can last between one and five minutes.

Generalized absence epilepsy

Unlike the tonic–clonic type, the symptoms of this epilepsy are more understated. The individual may experience frequent periods of unexpected loss of concentration (less than 20 seconds worth), called an aura. Because the type involves a loss of consciousness, individuals are not aware that a seizure has occurred. This symptom is present in around 10 percent of epilepsies (Lee 2004) and seems to be restricted to childhood (between ages 4 and 12). Some children who experience this type will go on to develop the tonic–clonic type (Delgado-Escuata *et al.* 1983).

Partial (focal) epilepsies

This type accounts for around 65 percent of epilepsies and is most common in adults (Gastaut *et al.* 1975). There are two general types of seizure characteristic of partial epilepsy: simple partial seizures and complex partial seizures (the more common). Simple partial seizures can produce sensory, motor or autonomic symptoms. For example, if the focus of the seizure is in the somatosensory cortex, the individual may experience pins and needles in the mouth, lips and fingers; if the focus is in the striate cortex, the individual may experience visual sensations such as sparks, flashes of light or dark spots.

Complex partial seizures usually begin with a warning – an aura that can include the urge to urinate or defecate, or result in intense fear (Lee 2004). The aura itself is a simple

partial seizure and is normally followed by lip smacking, chewing/swallowing and repetitive picking movements. The ictus can last several minutes and is characterized by very chaotic EEG (usually in the mesial temporal lobe). The patient normally has no memory for what follows. The individual may show abnormal posturing of the side of the body contralateral to the discharge during ictus. During the post-ictal period (which can last between two and ten minutes), the individual may feel very disoriented and will lack attention. The cause of this type is not known, although it appears to be associated with brain tumour in later life (Schomer 1983).

Because the focal point of the seizure is the temporal lobe, individuals will show symptoms of memory impairment after (as the case study of PO showed in Chapter 9). Learning new information may be difficult, and if the discharge extends to the back of the left hemisphere, deficits in reading and writing can occur. The greater the number of seizures in partial generalized tonic–clonic type, the worse the neuropsychological test performance (Dodrill 1986). Also, the earlier the onset, the worse the neuropsychological outcome (Strauss *et al.* 1995).

Cognitive impairment in epilepsy

The term ‘transient cognitive impairment’ has been coined to describe the cognitive impairments that follow neuronal discharges in epilepsy (Aarts *et al.* 1984). According to one study, these transient impairments can be found in up to 50 percent of patients (Binnie *et al.* 1991).

Various types of discharge have been associated with different cognitive outcomes. Spikes in the mesial temporal lobe have been associated with short-term memory impairment, whereas spikes in the left hippocampus have been associated with visual and spatial short-term memory deficits (Krauss *et al.* 1997). As one might expect, patients with discharges specifically in the temporal lobe show greater memory impairment than individuals with primary generalized epilepsy, who in turn have poorer memory than healthy controls (Bornstein *et al.* 1988). When partial seizures involve the left temporal lobe, deficits in the ability to learn new verbal information have been reported (Hermann *et al.* 1987). The converse – non-verbal and spatial information impairment – has been reported following right temporal lobe discharges but is less consistently seen (Delaney *et al.* 1980).

If seizure-inhibiting drugs are not effective, a radical but effective treatment for epilepsy is surgery (involving removal of part of the cortex or, in rare cases, all of it). The removal of the anterior temporal lobe results in impaired verbal recall and impaired free recall following a delay between presentation of the material and retrieval. Working memory can also be impaired (Seidenberg *et al.* 1998).

Disorders of mood

The majority of the studies reviewed in Chapter 10 were concerned with the measurement of normal emotion: whether brain activity can distinguish between the individual’s happy response and disgusted response, for example. Studies such as these can indicate some of those brain regions and mechanisms that govern our responses to stimuli that move us, either positively or negatively. However, some emotional responses go beyond the normal

experience of happiness and sadness into the realm of the clinical. Clinical emotional disorders, so-called affective disorders, are distinguished from normal emotional or mood changes in a number of ways. The *DSM-IV* lists a number of criteria that a patient must meet before he or she is considered to be clinically depressed or anxious, for example. Most of us will experience mood changes occasionally: elation at having got a better-paid job, achieving a high grade in an exam, becoming a parent, winning the lottery. We might experience sadness at the death of a friend or relative, at failing to win an important business order or at failing exams. However, while upsetting, these experiences are not normally long-lasting and do not usually impair an individual's way of life permanently. Clinical emotional disturbances, if they go untreated, are long-lasting and do impair the individual's normal way of life.

The most common disorders of mood and affect are depression and mania. There are other emotional disorders classed as anxiety disorders, including phobias, generalized anxiety disorder and obsessive–compulsive disorder. These disorders involve an extreme emotional response – clinical anxiety or depression. Whereas normal mood shifts can disappear relatively easily, clinical mood changes are normally alterable only by medication or intensive behavioural or cognitive therapy. In this chapter, the neuropsychological basis of these two types of disorder – depression and anxiety – are considered.

Depression: a description

Although swings in everyday mood are normal, a more persistent and continuous mood change indicates a clinical problem. The symptoms of depression depend on the degree of depression experienced. Thus some individuals will be miserable and show little interest in normally interesting activities (moderate depressive disorder). They might be pessimistic about the present, past and future and feel helpless. Other individuals might experience the same thoughts and feelings but at a greater intensity (severe depressive disorder). At the other end of the scale, individuals might experience bouts of mania, which alternate with depressive episodes. Individuals exhibiting mania are overactive, erratic, disinhibited, hypersexual, highly frustrated, demanding, flirtatious, insomniac and irritable. When manic episodes alternate with depressive episodes, the condition is described as a bipolar disorder. When depressive episodes alone are observed, the condition is described as unipolar. This unipolar/bipolar distinction is widely used.

Unipolar, or major, depression is characterized by depressive symptoms that have spanned at least two weeks. It is twice as common in women as in men (bipolar disorder shows no sex difference), and symptoms tend to be worse in the morning. According to one study, depressive disorders are likely to be the second most common diseases by 2020 (Brown 2001), with the World Health Organization noting that depression accounts for 4.4 percent of the world's disease burden, equivalent to the burden of ischaemic heart disease and asthma combined (WHO 2002). Around 2 percent of people in the UK are thought to suffer from major depression (Hale 1997), and the cost of the disorder to the UK economy has been estimated at £3.4 billion (Jonsson and Bebbington 1994). According to the *DSM-IV*, a major depressive episode is characterized by five (or more) of the following being present in the same two-week period:

- depressed mood most of the day;
- diminished interest/pleasure in day-to-day activities;
- significant weight loss or weight gain; decrease in appetite;

- insomnia or hypersomnia;
- psychomotor agitation;
- fatigue/loss of energy;
- feelings of worthlessness/inappropriate guilt;
- lack of concentration; indecisiveness;
- recurrent thoughts of death.

In addition, symptoms cause significant distress/impairment in social and occupational functioning and are not the result of substance use/medical condition. They cannot be accounted for by an obvious event such as bereavement.

The classification of depression into further subcategories is problematic. A number of these fractionated classifications have been suggested. For example, a distinction has been made between primary and secondary depression, where the latter occurs with another, primary, illness. Mild depressive disorders have been classed as neurotic depression, whereas severe depressive disorders have been classed as psychotic depression. Whether these disorders are discrete and independent or represent a continuum is unclear. The term 'reactive depression' has been used to describe a response to an external cause, whereas endogenous depression describes a disorder that cannot readily be attributed to an external cause. Although a popular distinction, there is evidence that depressive symptomatology is not that simple, with adverse life events preceding depressive episodes, whether the depression is endogenous or reactive (Bebbington *et al.* 1988).

There is some evidence for a genetic influence in affective disorder. Concordance rates of 50–70 percent have been found in monozygotic twins, where one twin has a severe affective disorder; for dizygotic twins, the concordance rate is 13–20 percent. The rates are paralleled in a limited number of studies of separated and adopted twins. The genetic influence appears to be greater for bipolar than for unipolar disorder. Linking the genetic influence to a chromosome marker has not been entirely successful. Predisposing factors for affective disorder are many, although the actual influence they have is open to question. Candidates have included maternal deprivation and parental relationships (the evidence for this is inconsistent), personality disturbance (likely), adverse life events such as bereavement or separation (again, likely), the vulnerability of the individual to life events (i.e. the individual may be predisposed to the disorder, but the disorder needs a major event to trigger it off), and season of birth.

Neuropathology of depression

Neuropathological *post mortem* studies of depressives' brains are not particularly common. The available evidence shows cortical cell loss in the temporal and frontal regions (Bowen *et al.* 1989). CT scans show larger ventricles in 10–30 percent of patients with affective disorders when compared with controls. The difference between the two groups is quite small and possibility also exists that the patients' drug regime was responsible for the finding. A reduction in glucose metabolism has also been found in the left frontal lobe of depressed patients (Baxter *et al.* 1989) and, as noted in the section on normal emotion, left frontal-temporal and right posterior lesions have been associated with subsequent depression.

Davidson and his colleagues have found less frontal activation both in individuals selected on the basis of their Beck Depression Inventory scores and in clinically depressed patients (Schaffer *et al.* 1983; Henriques and Davidson 1991). In a neuroimaging study, activity in the prefrontal cortex near the top of the corpus callosum was reduced in individuals with unipolar and bipolar depression (Drevets *et al.* 1997). This

part of the prefrontal cortex is called the anterior cingulate cortex, and a specific region within it, which has been called subgenual region, sg24, is less active in people with mood disorder, as Plate 12.1 shows.

Drevets *et al.* found that the volume of this region was lateralized to the left hemisphere, which is consistent with the data and model of normal emotion described in Chapter 10. These findings were subsequently replicated in a group of people with severe mood disorder (Hirayasu *et al.* 1999). When Drevets and his colleagues went on to explore the cellular nature of this region in people with mood disorder, they found the typical reduction in sg24 but also a reduction in the density of cells and in the number of glial cells (Ongur *et al.* 1998). A further study, using a larger sample, found that same pattern of cell reduction in a group of individuals with major and bipolar depression, but only in a subset with a family history of the disorder (Torrey *et al.* 2000). These cells carry neurotransmitter receptors and help to transport neurotransmitters, which may explain why their reduction is associated with depression. The reduction might also explain why this area is seen as smaller in people with depression and bipolar depression.

Neurochemistry of depression

Neurochemical changes in depressed patients (usually seen as a change in neurotransmitter level and function, and neurotransmitter metabolite and receptor function) have been observed from four principal sources: the patient's blood plasma, urine, cerebrospinal fluid (CSF) and *post mortem* brain. The first three sources are not particularly informative, since it is not known to what extent the level of neurotransmitter in these fluids is reflective of their level in the brain. The principal chemicals studied have been the monoamines dopamine, noradrenaline, 5-hydroxytryptamine (5-HT or serotonin) and their metabolites. Reduced levels of the dopamine metabolite homovanillic acid have been found in the cerebrospinal fluid of depressed patients. No change in levels of noradrenaline has been found, but levels of 5-hydroxyindoleacetic acid are reduced in some patients. However, this reduction is present after recovery, suggesting that it is not a distinctive neurochemical characteristic of depression. It is also far more consistent in patients attempting suicide. *Post mortem* brain studies of depressed individuals have normally focused on suicides, although whether all patients were depressed before committing suicide is unclear. No dopamine or noradrenaline changes have been observed in these brains.

There is inconsistent evidence that the number of beta-adrenergic receptors and certain serotonin receptors (5-HT₁ and 5-HT₂) is increased in depressed subjects (Arora and Meltzer 1989), sometimes in the prefrontal cortex (Arango *et al.* 1990). Some studies have suggested that depression is associated with a dysfunction in the serotonin system, with a decreased level of serotonin neurotransmission (Malone and Mann 1993). Early theories argued that presynaptic function in 5-HT neurons was decreased, although the absence of decreased levels of 5-HT argued for the hypothesis that postsynaptic neurons were not responsive to normal levels of 5-HT. There is no conclusive evidence either way. Some studies report lower plasma tryptophan levels, reduced CSF 5-hydroxyindoleacetic acid levels and decreased platelet 5-HT reuptake; others report increased 5-HT receptors in the brains of suicides (Malone and Mann 1993).

In a study to determine the effects of reducing tryptophan, a precursor of serotonin synthesis, in depressed patients, Delgado and his colleagues depleted the tryptophan levels in forty-three untreated depressed patients who later received antidepressant medication (Delgado *et al.* 1994). This depletion reduces brain 5-HT function. If the presynaptic hypothesis is correct, decreasing 5-HT levels should exacerbate depression; if

the postsynaptic hypothesis is correct, decreasing 5-HT levels should not have a significant effect, because postsynaptic cells are not particularly responsive in the first place. In their patients, there was no self-reported mood change on the day of depletion, but there was the following day: 37 percent had a 10-point or greater decrease in the Hamilton Depression Rating Scale, while 23 percent had a 10-point or greater increase. The authors argue that the findings indicate that serotonin function is not linearly related to the level of depression; reduced serotonin function is a predisposing factor or is due to 'a postsynaptic deficit in the utilization of serotonin'.

In addition to the amines, GABA levels have been found to be lower in the cerebrospinal fluid and plasma of individuals with unipolar depression (Brambilla *et al.* 2003). When depressed individuals are given drugs that increase the level of serotonin at serotonergic neurons or are given ECT, the decrease in GABA concentration seen in the occipital cortex is reversed (Sanacora *et al.* 2002, 2004). However, the role of the two classes of GABA (the A and B classes) in depression is unclear.

However, pharmacological treatments of the disorder act on a number of neurotransmission systems.

Pharmacological treatment of depression

The most well-known pharmacological treatments for depression are the monoamine oxidase inhibitors (MOIs; e.g. phenelzine, iproniazid, tranylcypromine, brofaromine, moclobemide) and tricyclic antidepressants (e.g. desipramine, imipramine, clomipramine). Monoamine oxidase (MO) A and B are important for the metabolism of dopamine, noradrenaline and 5-HT. The principal pharmacological treatments for depression are listed in Table 12.1.

Drugs that inhibit MO tend to have antidepressant effects in mild but not severe depression (an inhibition of 80 percent of MO must be observed before antidepressant effects are observed). One major side-effect of MOIs is the 'tyramine-cheese reaction', a hypertension resulting from the high concentration of tyramine in certain foods consumed, such as cheese, beer, chocolate and pickles. As the monoamine oxidase no longer metabolizes tyramine, the tyramine displaces noradrenaline from adrenergic nerve endings. The behavioural result is that the patient might develop occipital headaches and begin vomiting, experience chest pain and become restless. Although a short-term reaction, it could lead to intracranial bleeding. If this occurs, it could be fatal.

Earlier MO inhibitors such as phenelzine, iproniazid and tranylcypromine inhibited forms A and B of MO and inhibited the enzyme irreversibly. It now appears that the A type is important in exerting antidepressant effects. Newer drugs such as brofaromine and moclobemide have reversible effects. It is not known precisely which monoamine's inhibition is likely to be more important. Also, it is puzzling why acute inhibition occurs a few days following drug administration but the antidepressant effect is not seen until about three weeks later. It has been suggested that the inhibition leads to subsequent long-term change (Strange 1992).

Tricyclic antidepressants are the most popular antidepressant drugs. So called because of their common three-ring structure, tricyclics, like MOIs, take a few weeks to reach maximum effect and are thought to inhibit the reuptake of monoamines in the nerve terminal, resulting in an increased level of monoamine at the synapse. Side-effects of the drugs include blurred vision, dry mouth (an anticholinergic response), postural hypotension (an antiadrenergic response) and drowsiness (an antihistamine response). The different tricyclic drugs also inhibit reuptake of the three monoamines selectively, with one drug inhibiting one monoamine better than it would another.

Table 12.1 Some of the drugs used to treat depression

Substance	Generic name	Example
Noradrenaline-reuptake inhibitors (Tertiary amine tricyclics)	Amitriptyline	Elavil
	Clomipramine	Anafranil
	Doxepin	Adapin, Sinequa
	Imipramine	Tofranil
	Trimipramine	Surmontil
Noradrenaline-reuptake inhibitors (Secondary amine tricyclics)	Amoxapine	Asendin
	Desipramine	Norpramin, Pertofrane
	Maprotiline	Ludiomil
	Nortriptyline	Pamelor
	Protriptyline	Vivactil
Serotonin-reuptake inhibitors	Fluoxetine	Prozac
	Fluvoxamine	Luvox
	Paroxetine	Paxil
	Sertraline	Zoloft
	Venlafaxine	Effexor
Atypical antidepressants	Bupropion	Wellbutrin
	Nefazodone	Serzone
	Trazodone	Desyrel
Monoamine oxidase inhibitors	Phenelzine	Nardil
	Tranlycypromine	Parnate
	Selegiline	Eldepryl

Source: Baldessarini 1996a.

Another group of drugs, so-called second-generation drugs, have been modelled on the presumed pharmacological action of previous antidepressants. The original antidepressants (MOIs and tricyclics) were not designed specifically as antidepressants but were found to have antidepressant effects. The new drugs such as maprotiline and fluoxetine (Prozac) inhibit the reuptake of noradrenaline and 5-HT, respectively. The drugs are effective and have few of the tricyclics' side-effects. Oddly, although these drugs selectively inhibit reuptake and have effective antidepressant effects, cocaine (which inhibits noradrenaline uptake) is a poor antidepressant.

Other 'biological' treatments have included L-tryptophan, an amino acid, which appears to work via an increase in levels of 5-HT. Taken with MOIs, L-tryptophan has been found to be an effective antidepressant, perhaps enhancing MOI action. Electroconvulsive therapy (ECT) may be an effective antidepressant for patients with severe, endogenous depression who do not respond to tricyclics (Kendell 1981). However, effects are not long-lasting, and relapses are high. Lithium carbonate is an effective drug treatment for mania and recurrent unipolar affective disorder but has a slow onset (Schou 1989).

Two recent developments in the psychopharmacology of depression have been second-generation (atypical) antidepressants, which block either noradrenaline reuptake or dopamine reuptake, and dual-action antidepressants, which block certain serotonin receptors while inhibiting its reuptake. An example of the former, nefazodone, was released in 1995; an example of the latter, mirtazapine, was released in 1997.

The important factor in assessing the effect of antidepressant medication is the maintenance phase of the treatment. In the initial period of drug-taking, there is an acute phase in which the acute symptoms begin to stabilize. This period can last up to three months (Hirschfeld 2001). The next period extends between the end of the acute period and the end of the depression itself, a period that can take up to six to twelve months. The danger is that if patients had stabilized in the acute phase, then they would have medication withdrawn. According to Hirschfeld (2001), however, around a third to a half of people who successfully stabilize in the acute phase will relapse if medication is not sustained.

Neurochemical hypotheses of depression

As the most effective biological treatment of clinical depression involves some form of pharmacological action, it is unsurprising that biological theories of the aetiology of depression have focused on neurochemical systems and changes.

Cholinergic hypothesis

The cholinergic hypothesis was one of the earliest neurochemical theories of depression; it suggested that an imbalance between the cholinergic and catecholamine systems led to an alteration in mood (Janowsky *et al.* 1972). More cholinergic activity was thought to produce depression; more relative catecholaminergic activity was thought to produce mania. However, there is little evidence to suggest the involvement of cholinergic systems in depression, and the hypothesis is an informational slave to the period of its formulation, i.e. we have more information about antidepressant neurochemistry today.

Monoamine hypothesis

This is the most influential neurochemical hypothesis of depression; it is based on the effects of two drugs administered to patients in the 1950s, when a drug (reserpine) used to alleviate hypertension became associated with depressive symptoms in some patients. Animal studies indicated that it reduced levels of dopamine, noradrenaline and 5-HT in rats. Two other drugs that inhibited MO and were used to combat tuberculosis – iproniazid and isoniazid – appeared to produce a lightening of the depression experienced by tubercular patients. These two separate findings suggested that depression was produced by a reduction in monoamine neurotransmitter and that returning monoamine levels to normal would lead to a removal of the depression. Tricyclic drugs, as discussed above, inhibit monoamine reuptake, thus potentially increasing synaptic levels of the monoamines. The important monoamine candidates are considered to be noradrenaline and 5-HT. Interestingly, patients with seasonal affective disorder have disturbed 5-HT metabolism (Wurtman and Wurtman 1989).

There are a number of problems with the hypothesis, however. First, it is unclear whether antidepressant drugs increase the levels of synaptic monoamines. Second, the newer drugs selectively inhibit monoamines, thus indicating that linking a specific neurochemical monoamine change with mood change is difficult. Furthermore, antidepressant drugs such as iprindole do not alter levels of synaptic monoamine. Finally, why do the tricyclics and MOIs take neurochemical effect almost immediately but take behavioural effect up to six weeks later?

Specific monoamine hypotheses

Newer theories, such as the noradrenergic hypothesis, attempt to account for some of these shortcomings. The noradrenergic hypothesis states that changes in the efficiency of synapses are due to presynaptic alpha 2-adrenergic receptors altering the synapses' control of neurotransmitter release. Chronic administration of antidepressants increases

synaptic efficacy. Because all of this is a slow process, it might explain the delay in the behavioural action of the drugs. However, as yet, there is no human evidence that depression results from highly sensitive presynaptic alpha 2-adrenergic receptors, which in turn lead to reduced noradrenaline release.

An alternative hypothesis argues that postsynaptic beta-adrenergic receptors are increased in depressed patients and that antidepressants return the numbers to their normal level. Giving a patient a receptor agonist should therefore exacerbate the depression. There is no evidence that this happens either.

One final hypothesis, the 5-HT hypothesis, argues that depression results from reduced 5-HT (as noted above) and that antidepressants increase the efficacy of 5-HT systems. Thus the behavioural delay in symptom alleviation is accounted for by the fact that the drugs produce a slow increase in the efficacy of 5-HT synapses.

Anxiety: a description

The term ‘anxiety’ describes a number of disorders characterized by danger, distress or fear. According to one account, it may be present in 27 percent of primary care patients (Wittchen 2002). Various neurotic syndromes are described by the term ‘anxiety’. According to the *DSM-IV*, these are panic attack, specific phobia, social phobia, post-traumatic stress disorder, obsessive–compulsive disorder and generalized anxiety disorder. Until the *DSM-III* (1980), these disorders were grouped under the nebulous classification of ‘neurotic disorders’.

Common to all, to some extent, are awareness of threat, tension, difficulty in concentration, fear, restlessness, sleep disturbance, increased muscle tension, gastrointestinal alteration such as dry mouth, nausea and diarrhoea, difficulty in respiration, and increased sweating. The incidence of GAD is about 3–6 percent; the lifetime risk for phobia is 10 percent, for panic disorder 1 percent, and for obsessive–compulsive disorder 2–3 percent. A 40 percent concordance rate for anxiety disorder is seen in monozygotic twins, whereas 15 percent or less is found for dizygotic twins (Mahmood *et al.* 1983; Marks 1986).

Neuropsychology of panic disorder

Panic disorder, characterized by panic attacks, is underpinned by complex neural circuitry. The *DSM-IV* criteria for panic disorder are four or more of the following features experienced in ten minutes:

- palpitations, pounding heart, accelerated heart rate
- sweating
- trembling, shaking
- shortness of breath
- feeling of choking
- chest pain
- nausea
- feeling dizzy, unsteady
- feelings of unreality, feeling detached
- fear of losing control

- fear of dying
- numbness, tingling
- chills, hot flushes.

One view sees the disorder as a normal anxious response that is inappropriately and spontaneously provoked by ‘homeostatic imbalance’ (Cannistraro and Rauch 2003). Cerebral blood flow studies suggest a role for the temporal lobe, and regions within this area, in panic disorder. Reiman *et al.* (1986) found that the left–right ratio of parahippocampal activity was lower in patients with panic disorder when they were at rest. Asymmetric rCBF activation in the parahippocampal gyrus was found in these patients before an attack (*ibid.*). Another study reported increased activation in the left hippocampus and parahippocampal gyrus but decreased activation in the right superior temporal regions (Bisaga *et al.* 1998).

A recent paradigmatic development in the anxiety literature has been the introduction of the method of symptom provocation – in this paradigm, symptoms are (as the name suggests) provoked experimentally, and the neural and behavioural consequences can be observed and measured. Using this method, fMRI studies have shown that the cortex appears to be more activated than earlier approaches suggested – increases in the inferior frontal, cingulate and orbito-frontal cortices and the hippocampus have been reported (Bystrinsky *et al.* 2001).

Brain structure appears to be altered in patients with panic disorder, and these structural abnormalities are seen in regions similar to those implicated by functional techniques. Bilateral temporal lobe abnormalities (but not hippocampal abnormalities) and decreases in parahippocampal grey matter have been reported (Vythilingam *et al.* 2000; Massana *et al.* 2003). A model of panic disorder based on neural dysfunction/activation can be seen in Figure 12.1 (a)–(e).

Figure 12.1

Models of anxiety and brain regions implicated in anxiety: (a) general; (b) PTSD; (c) specific phobia; (d) social phobia; and (e) panic disorder (from Cannistraro and Rauch 2003)

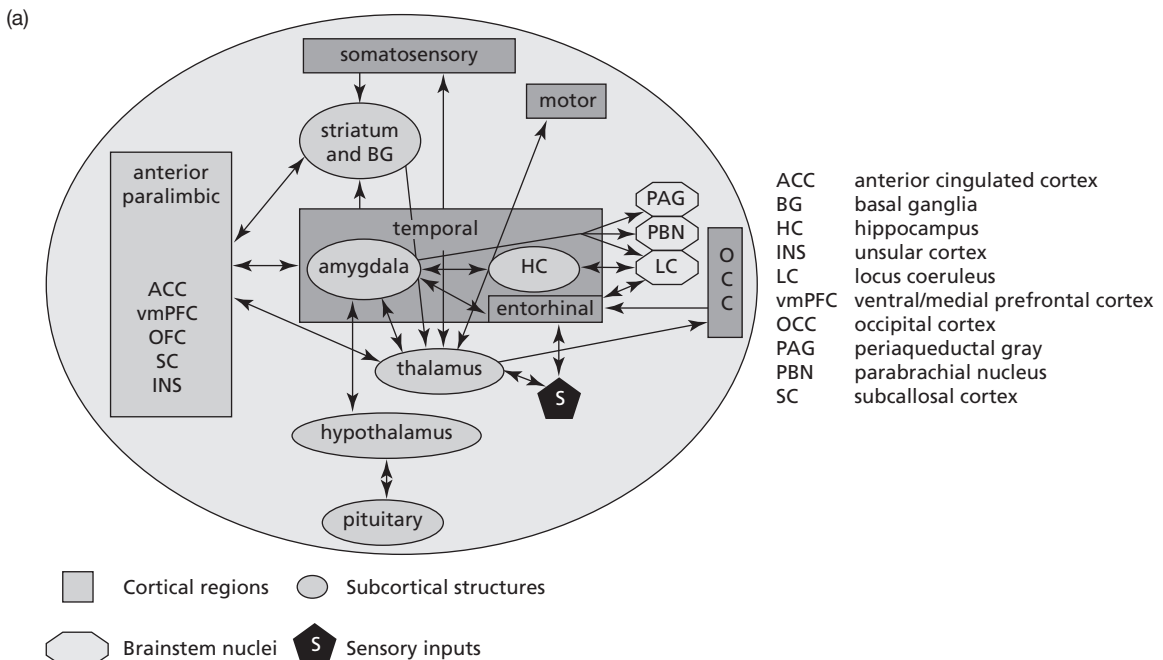

(b) Areas implicated are highlighted in white

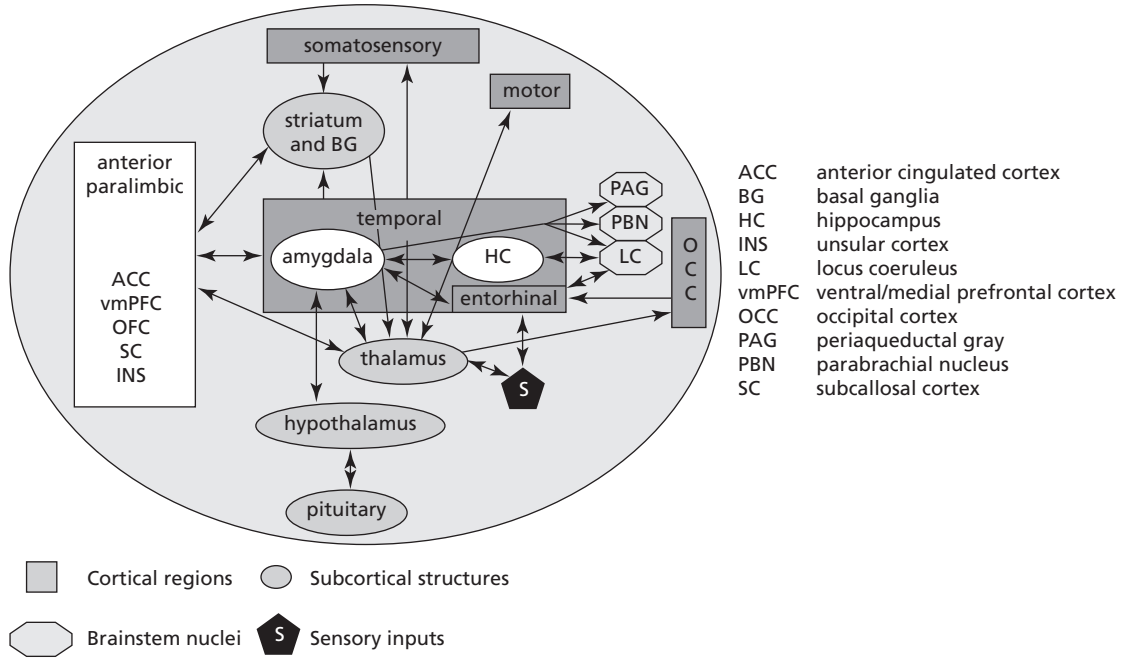

(c) Areas implicated are highlighted in white

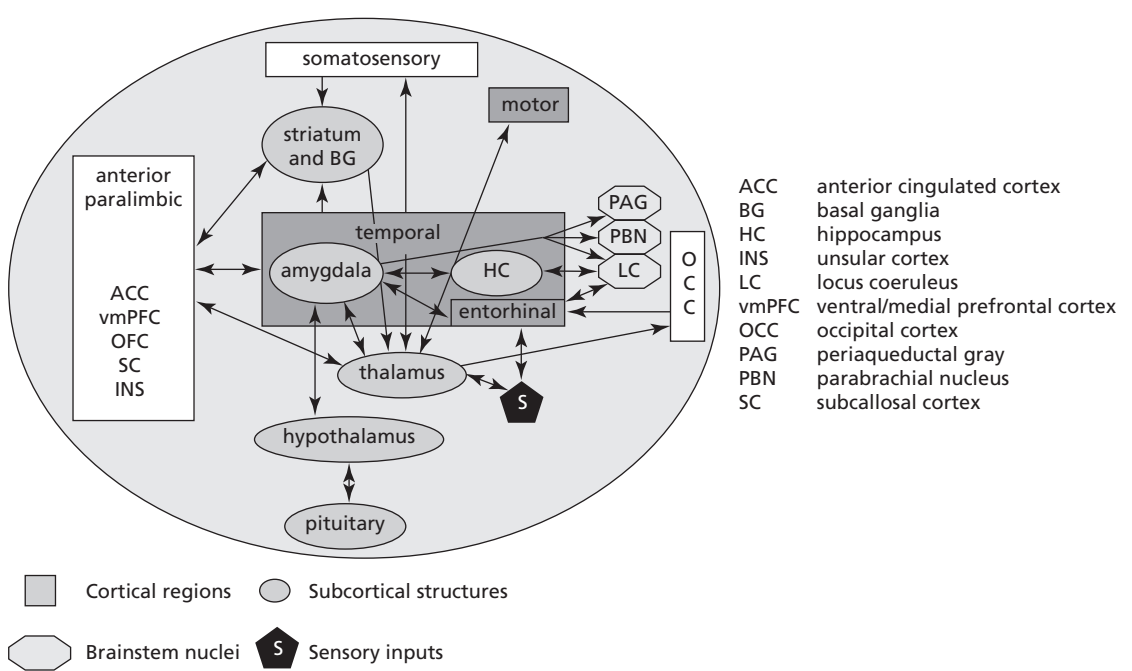
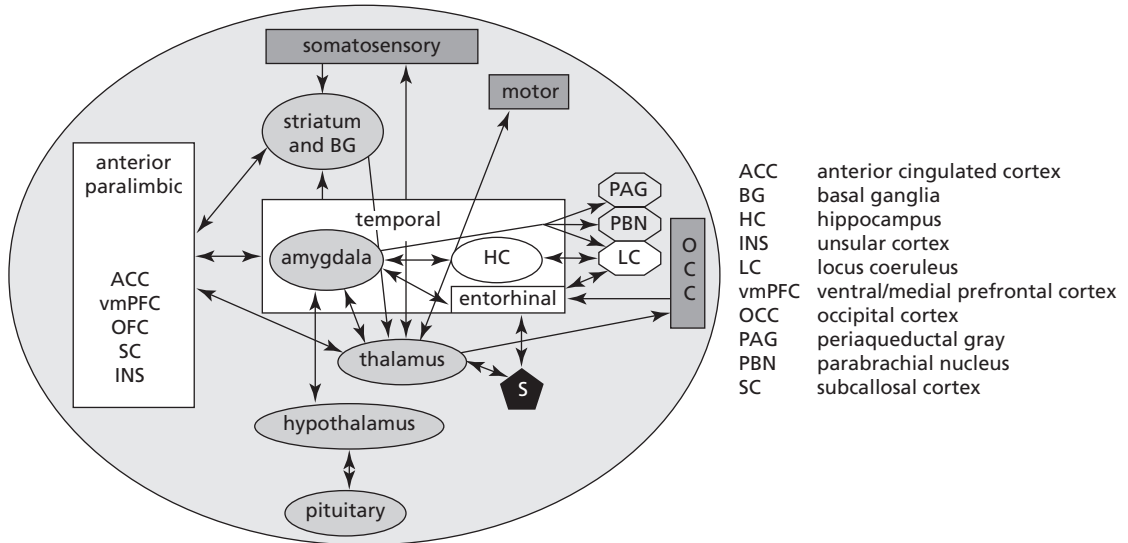

Figure 12.1 continued

(d) Areas implicated are highlighted in white



- ACC anterior cingulate cortex
- BG basal ganglia
- HC hippocampus
- INS insular cortex
- LC locus coeruleus
- vmPFC ventral/medial prefrontal cortex
- OCC occipital cortex
- PAG periaqueductal gray
- PBN parabrachial nucleus
- SC subcallosal cortex

■ Cortical regions ○ Subcortical structures

⬡ Brainstem nuclei ⬠ Sensory inputs

(e) Areas implicated are highlighted in white

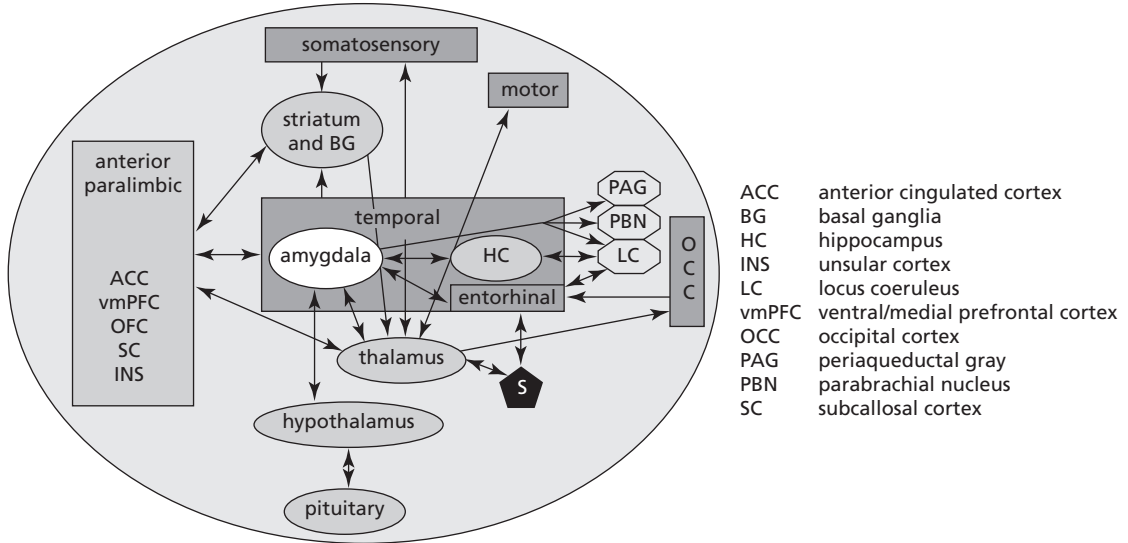

- ACC anterior cingulate cortex
- BG basal ganglia
- HC hippocampus
- INS insular cortex
- LC locus coeruleus
- vmPFC ventral/medial prefrontal cortex
- OCC occipital cortex
- PAG periaqueductal gray
- PBN parabrachial nucleus
- SC subcallosal cortex

■ Cortical regions ○ Subcortical structures

⬡ Brainstem nuclei ⬠ Sensory inputs

Neuropsychology of specific and social phobia

Although classified as phobias and characterized by the typical phobic features, specific and social phobias have distinct differences that may be underpinned by different neuropsychology. According to the *DSM-IV*, the principal symptoms of specific and social phobia are:

Specific phobia

- marked, persistent fear that is excessive or unreasonable cued by the presence/anticipation of an object or situation;
- exposure to the phobic stimulus produces anxiety;
- recognition that fear is excessive or unreasonable;
- phobic situation is avoided or experienced with distress;
- avoidance or anxiety interferes with person's routine (personal, social or occupational);
- not better accounted for by another disorder.

Social phobia

- marked and persistent fear of one or more social situations involving exposure to unfamiliar people or scrutiny by others;
- exposure invariably leads to anxiety, including panic attacks;
- recognition that fear is excessive or unreasonable;
- situations are avoided or endured with distress;
- avoidance or anxiety interferes with person's routine (personal, social or occupational);
- not attributable to medical condition.

In terms of emotional responding, patients with specific phobias appear to show differences in brain activation compared with controls. Abnormalities in activation in the insula, for example, have been reported when such patients are asked to view facial expressions of emotion (Wright *et al.* 2003), although no differences in the amygdala were reported. When symptoms are provoked, various neural features have been observed, from increased secondary visual cortex, left somatosensory cortex, left thalamus and paralimbic activation to decreased prefrontal cortex, posterior cingulate and hippocampal activation (Wik *et al.* 1993; Rauch *et al.* 1995). When individuals who fear spiders (a condition called arachnophobia) were exposed to films of the creatures, one fMRI study reported increased activation in the prefrontal cortex near the Rolandic fissure, the parahippocampal cortex and the bilateral visual cortex (Paquette *et al.* 2003). When such patients are treated – with the commonest behaviour treatment, cognitive behavioural therapy – the activation in the frontal and parahippocampal cortex is reduced. Although the disorder clearly involves the fear of an object or event, the amygdala is not as implicated as are the anterior paralimbic and sensory cortical regions.

However, the amygdala does appear to play a more important role in social phobia. Lesions in monkeys result in an impaired ability to detect and avoid danger (Amaral 2002). fMRI studies have found that the amygdala is activated in individuals with social phobia when they watch neutral facial expressions; amygdalar and hippocampal activation have also been reported when individuals view neutral faces that are paired with an aversive stimulus (Birbaumer *et al.* 1998). These findings indicate that the two classes of phobia are neurally separable and may therefore have different underlying neural mechanisms.

Neuropsychology of post-traumatic stress disorder (PTSD)

Of the anxiety disorders, PTSD is probably the one that is more likely than others to be caused by conditioning: the experience of a specific event causes trauma, and the thought of the event reinstates that feeling of fear and anxiety. Individuals with specific phobia, for example, rarely identify an experience of the feared object as the source of their anxiety.

According to the *DSM-IV*, PTSD is characterized by the following symptoms:

- Exposure to traumatic event in which the person witnessed, experienced or was confronted with event that involved real or threatened death or serious injury to self or others.
- Exposure to traumatic event caused intense fear, helplessness or horror.
- The traumatic event is persistently experienced in one or more of the following ways: recurrent or intrusive distressing recollections including images, thoughts or perceptions; recurrent distressing dreams; acting or feeling as if traumatic event was recurring; intense distress to cues that symbolize or resemble aspect of the event; physiological reaction to such cues.
- Stimuli associated with the trauma are persistently avoided by three or more of the following: efforts to avoid thoughts, feelings or conversations associated with trauma; efforts to avoid activities, places and people arousing recollections of the event; inability to recall specific aspects of the event; diminished interest/participation in activities; feeling of detachment/estrangement from others; restricted affect; sense of foreshortened future (no career, marriage, children).
- Persistent symptoms of increased arousal indicated by two or more of the following: difficulty in falling/staying asleep; irritability or outbursts of anger; difficulty in concentration; hypervigilance; exaggerated startle response.
- Duration of symptoms is more than one month.
- Disturbance causes clinical distress.

Regions and structures implicated in PTSD include the amygdala and prefrontal cortex. The amygdala is very responsive to threat-related stimuli, but this responsiveness is augmented in PTSD (Rauch *et al.* 1998). Two explanations may account for this: either the prefrontal cortex and other regions fail to moderate the amygdalar activation, or the amygdala is inherently over-responsive and impairs the function of other regions because of this excessive activation (Cannistraro and Rauch 2003). An early PET study employing symptom provocation found increased activation in the right orbito-frontal cortex, the insula, and the anterior temporal and visual cortices when symptoms were produced (Rauch *et al.* 1996), a finding that has been replicated with additional activation reported in the locus coeruleus, thalamus and hypothalamus (Charney and Bremner 1999).

However, it is acknowledged that exposure to trauma does not routinely or automatically cause PTSD. There may therefore be differences between individuals who experience similar trauma but who do or do not develop PTSD. In studies that have investigated such potential differences, increases in amygdala activity have been found in PTSD individuals during symptom provocation, as has decreased activation in the medial frontal cortex (Liberzon *et al.* 1999; Bremner *et al.* 1999). The amygdala was found to be more reactive in individuals with PTSD during exposure to trauma than it was in non-PTSD individuals exposed to the same trauma (Rauch *et al.* 2000), and this increase correlated with the severity of the symptoms: the more severe they were, the greater the activation observed. While increased reactivity is observed in the amygdala, hippocampal activation appears to be reliably diminished in PTSD (Bremner *et al.* 2003)

Neuropsychology of obsessive–compulsive disorder (OCD)

The symptoms of OCD include the presence of obsessions and compulsions. Obsessions include recurrent and persistent thoughts, impulses or images that are intrusive and inappropriate and cause anxiety. These thoughts and impulses are not excessive worries about real-life problems, and there is an attempt to ignore or suppress. The individual recognizes that the obsessions are a product of their mind (not imposed from outside). Compulsions include repetitive behaviour or mental acts that a person feels driven to perform in response to an obsession; behaviour is aimed at preventing distress or a dreaded event or situation, but not in a realistic way. There is recognition at some point that obsessions/compulsions are excessive or unreasonable, cause distress, are time-consuming (>1 hour) or interfere with a person's routine

As in specific phobia and panic disorder, there is little involvement of the amygdala in OCD. Instead, more cortical regions – and the connections between them – are involved. Specifically, the striatum and the frontal cortex may mediate the obsessive and compulsive behaviour, with the striatum primarily mediating repetitive stereotyped cognitions and an overactive frontal cortex mediating the presence of obsessions (but which itself is ultimately due to a defective striatum; Rauch *et al.* 1997). Evidence for the involvement of these regions arises from PET studies and studies of symptom provocation. At rest, increased activation is found in the striatum and orbito-frontal cortex in OCD (Jenicke *et al.* 1996) and during symptom provocation (Rauch *et al.* 1994). When OCD is treated, decreases in these regions have been observed (Perani *et al.* 1995; Schwartz *et al.* 1996).

Neuropsychology of generalized anxiety disorder (GAD)

According to Wittchen (2002), GAD is present in approximately 27 percent of primary care patients, but it is a controversial disorder because its symptoms are varied. Debate continues over whether it is a separate anxiety disorder or an offshoot of other anxiety disorders (Cannistraro and Rauch 2003). The *DSM-IV* lists the following symptoms of GAD:

- Excessive anxiety and worry, causing distress and occurring on more days than they do not for at least six months about a number of events or activities.
- Controlling the worry is difficult.
- Anxiety and worry are associated with three or more of the following: restlessness, being easily fatigued, difficulty in concentrating, irritability, muscle tension, sleep disturbance.

The neural basis of GAD is unclear but the occipital cortex, basal ganglia and limbic system have been implicated.

Pharmacological treatment of anxiety

Anti-anxiety drugs are called anxiolytics, and a number of compounds are used to alleviate the disorder, including barbiturates, benzodiazepines, azapirones and antidepressant drugs. Some of these are listed in Table 12.2. The most common pharmacological interventions target GABA using benzodiazepines (see below) or SSRIs. GABA is the brain's principal inhibitory neurotransmitter and comprises (at least) two classes: ionotropic GABA_A receptors and metabotropic GABA_B receptors. Some initial evidence from animal studies suggests that a deficiency in the latter leads to greater anxiety (Cryan and Kaupmann 2005).

Table 12.2 Some of the drugs used to treat anxiety

Substance	Generic name	Example
Benzodiazepines	Alprazolam	Xanax
	Chlordiazepoxide	Librium
	Clonazepam	Klonopin
	Clorazepate	Tranxene
	Diazepam	Valium
	Fluzarepam	Dalmane
	Halazepam	Paxipam
	Lorazepam	Ativan
	Midazolam	Versed
	Oxazepam	Serax, Zaxopam
	Prazepam	Centrax
	Quazepam	Dormalin
	Temazepam	Restoril
	Triazolam	Halcion
Atypical agent	Buspirone	Buspar

Source: Baldessarini 1996b; Julien 2004.

Barbiturates

Barbiturates, derivatives of barbituric acid, are sedative drugs and include barbital (developed in 1903) and phenobarbital. Once popular anxiolytics, their toxicity and their potential for fostering physiological and ‘psychological’ dependence/tolerance led to a gradual reduction in their use. Since the effects of withdrawal are severe, the possibility of death from overdose is a possibility, and other new drugs such as the benzodiazepines have become available, barbiturate prescription has become uncommon.

Benzodiazepines

These sedative and anticonvulsant compounds are the most frequently prescribed drugs in medicine and the most widely used anxiolytics. The most common of them are chlordiazepoxide (Librium; the first developed) and diazepam (Valium), which is three to ten times stronger. Both have been developed since the 1950s and are low in toxicity. Since then, derivatives have been manufactured such as oxazepam, clonazepam, lorazepam and clonazepam. Side-effects may be produced if the drug is taken for a long period, however, and these include sedation and impaired memory/concentration. Depression and outbursts of violence may also be seen. The drugs can also produce an amnesic effect.

After about four weeks, the body becomes tolerant to benzodiazepines and the drug becomes ineffective (Lader and File 1987). Withdrawal symptoms are marked after chronic administration, and approximately 40 percent of patients on long-term prescription experience them (the anxiety tends to be intensified post-administration). The tolerance to benzodiazepines and the withdrawal symptoms after their removal suggest selective administration, i.e. in the short-term alleviation of distress or in response to an immediately stressful situation.

Azapirones

Azapirones are a class of drug that became the first available alternative, non-barbiturate anxiolytic that was not sedative. Only one type was marketed – buspirone. Withdrawal

problems are common, and it is ineffective for panic disorder (Nemeroff 2003). However, it appears to be effective for GAD and conditions where the relief of anxiety need not be immediate (Harvey and Balon 1995).

SSRIs and histamine receptor antagonists

Antidepressants are sometimes prescribed to alleviate symptoms of anxiety, and the success of SSRIs has led to an increase in the prescription of these drugs to treat GAD. Citalopram, a new SSRI, produced an improvement in anxiety and depression in thirteen out of thirteen GAD patients who were unresponsive to traditional SSRIs (Varia and Rauscher 2002). The drug hydroxine, an antagonist of histamine receptors, also appears to be effective compared with a placebo (Llorca *et al.* 2002).

Alcohol

Unsurprisingly, this is the most widely used psychoactive substance in the world. At low doses, it has anxiolytic effects, although the response to the dosage is dependent on the responsiveness of the individual. Its disadvantages are many, and it has no long-term benefit.

Beta-blockers

Beta-blockers (e.g. propranolol) are beta-adrenergic receptor antagonists and are normally taken to alleviate extreme forms of stress. Angina patients are particularly prone to emotional upset, resulting in increased heart rate; together with a deficient coronary artery blood supply, this produces anginal pain. The accelerated beating of the heart is produced by stimulation of nerve endings called beta-receptors. Beta-blockers, as the name suggests, act by blocking these receptors and eliminating excessive stimulation of the heart. They also prevent the same kind of stimulation occurring during exercise: less blood is pumped out of the heart, and less oxygen is consumed.

Discussion point: can Gray's model help to explain human anxiety?

There are a number of psychological models to explain the psychology of anxiety but few provide an explanation of anxiety at the neuropsychological level. However, one model does (Gray 1982; Gray and McNaughton 2000). Based on a substantial review of animal data and the effects of anxiolytics in humans, Gray has argued that anxiety is evoked by signals of punishment, signals of lack of reward, novel stimuli and innate fear stimuli. A behavioural inhibition system (BIS), the brain system responsible, detects the threat and generates anxiety. Anxiety thus reflects the activity of the BIS (see Figure 12.2).

This system allows the organism to evaluate the environment for threat or possible threat and is thought to be represented by the septum and hippocampal formation, or septohippocampal system, which comprises a number of interacting brain structures, as seen in Figure 12.3. The system is interlinked and is relatively well separated from the rest of the brain by ventricles. Evidence for the involvement of this system comes from animal lesion studies, rCBF studies implicating the parahippocampal gyrus in panic attacks, and electrical stimulation studies in which

Figure 12.2

The behavioural inhibition system (original 1.1: from Gray and McNaughton (2000), adapted from Gray (1982) with the permission of the late Jeffrey Gray)

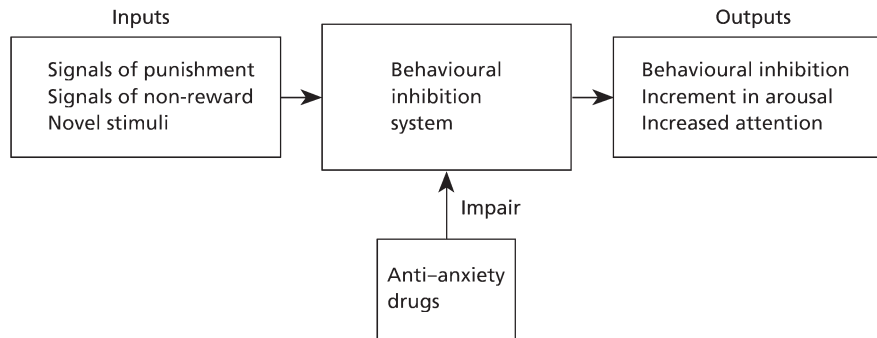

stimulation of the polar temporal cortex, the parahippocampal gyrus and the amygdala are associated with anxiety. Information about the state of the organism is obtained via the parahippocampal gyrus and information about possible outcomes from the prefrontal cortex. The subiculum is thought to be the structure that compares the actual and predicted outcome.

Figure 12.3

(a) The septohippocampal system (schematic) (with permission of Mrs V. Gray) and; (b) a diagrammatic representation of the SHS system (from Gray and McNaughton 2000)

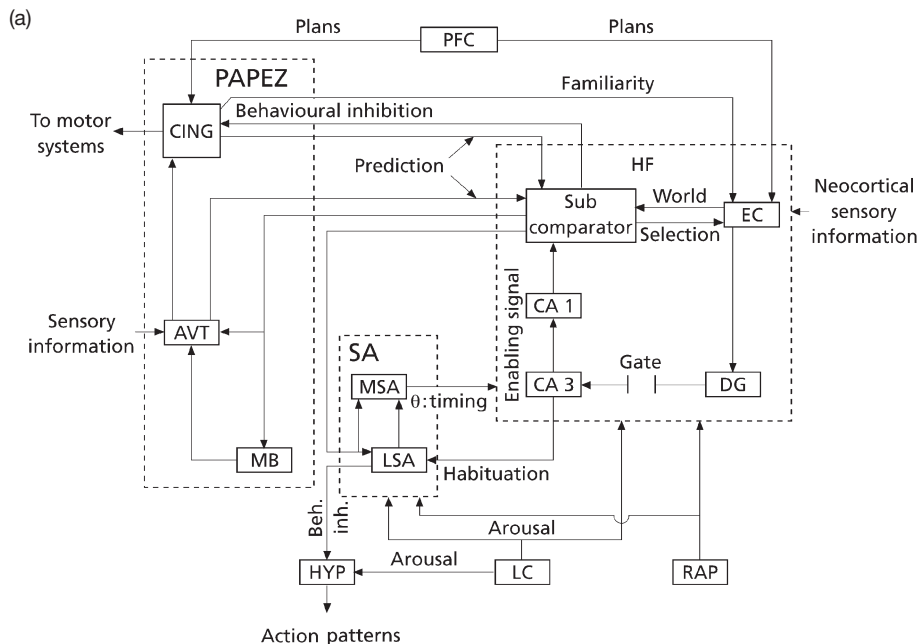

Key: HF=hippocampal formation; EC=entorhinal cortex; DG=dentate gyrus; SUB=subicular area; SA=septal area; MSA=medial septal area; LSA=lateral septal area; MB=mammillary bodies; AVT=antero-ventral thalamus; CING=cingulate gyrus; HYP=hypothalamus; LC=locus coeruleus; RAP=raphe nuclei; PFC=prefrontal cortex

Figure 12.3 Continued

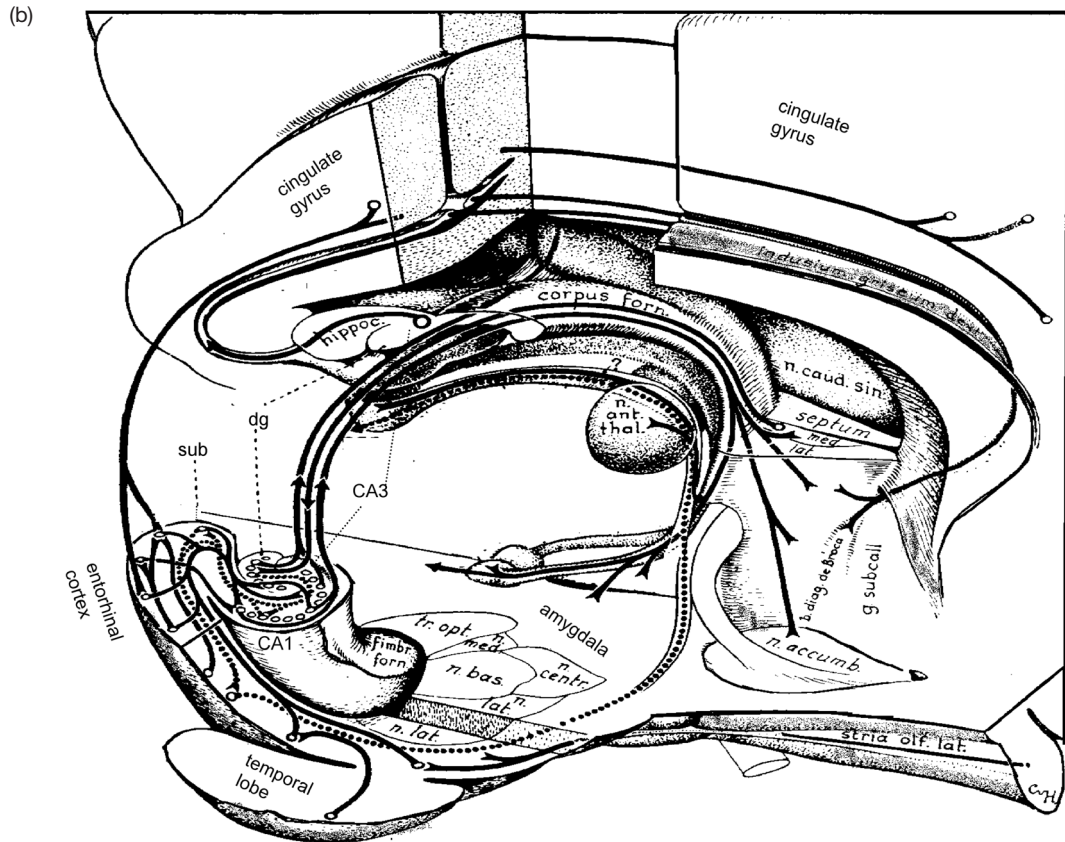

Gray also suggests that noradrenergic pathways linking the locus coeruleus to the septohippocampal system and 5-HT pathways linking the raphe to it may control some of the BIS's activity. Threats activate these pathways, which in turn affect the septohippocampal system.

However, there are other structures beyond those of the septohippocampal system that may mediate anxiety responses. Electrical stimulation of the amygdala, for example, may provoke anxiety or fear in laboratory animals. This structure may be important in the detection of threat from the environment, as LeDoux's experiments have demonstrated. Also important is the periaqueductal grey region, which also results in fear/anxiety when electrically stimulated. Both the amygdala and periaqueductal grey region are innervated by 5-HT systems. These structures are important because, as Gray (1995) himself admitted, the mechanism that one postulates for the mediation of anxiety depends on which system one uses as a starting point. LeDoux's work on the amygdala, for example, concerns the formation of conditioned responses that are not significantly affected by anxiolytic drugs. However, the responses elicited by conditioned stimuli can be alleviated by these drugs, and this is the focus of Gray's model.

In the first version of the model, the hippocampus was viewed as suppressing undesirable computations in other structures. The SHS acted as a comparator – the

current state of the organism was communicated to the comparator via input to the hippocampal formation from the entorhinal cortex. The frontal cortex and the basal ganglia would organize the motor programmes needed for movement and decision-based action. Based on the activity of these regions and those that store memories of past experiences, the comparator computes a prediction about the next likely state of the perceptual world. The comparison between this and the state of the world at the time (made by the subiculum) results in two possible decisions being made – a match (prediction confirmed) or a mismatch (prediction failed). The comparator controls behaviour and generates the output of the BIS and is, according to Gray and McNaughton, ‘the cognitive and computational heart’ of the BIS.

In the revised version, inputs to the hippocampus are seen as representing goals, and the structure detects conflicts between goals that are currently active (and not between conflicts in responses or motor acts). When conflict is evident, the hippocampus produces output (as do other structures in the SHS). Mirror drawing involves changing motor acts but has the same goal as normal drawing; this is why patient HM can perform mirror drawing perfectly well despite having had the hippocampus removed. This output increases the valence of negative stimuli and shifts the organism’s goal from ‘approach’ to ‘avoid’.

There is good evidence that anxiolytic drugs affect the septohippocampal system. GABA_A receptor modulators (such as the benzodiazepines) increase the inhibitory action of GABA. Noradrenergic neurons innervating the septohippocampal system are also inhibited in activating the septohippocampal system under the administration of these drugs.

According to Gray, the behavioural symptoms of anxiety reflect the behavioural inhibition of the BIS. This inhibition results in a phobic avoidance when the individual responds to a threatening stimulus. Symbolic or linguistic threats, such as fear of failure in an exam, may be mediated by the pathway that links the cortical language areas to the prefrontal cortex and from there onto the motor programming circuits of the basal ganglia. From here, the pathway leads to the hippocampal formation via the entorhinal cortex. Various other parts of the SHS are thought to be involved in various anxiety disorders.

The dorsal periaqueductal grey matter, for example, controls the immediate ‘anxiety’ response to a predator, such as freezing, fleeing or fighting. This behaviour can be elicited by pain, carbon dioxide, dominant conspecifics and predators. Animal studies have shown that stimulation of this region leads to undirected flight – the organism will crash into obstacles instead of overcoming them. This region is connected to the medial hypothalamus, where more sophisticated methods of escape are mediated. This in turn is connected to the amygdala, which coordinates simple avoidance. The amygdala is linked to the hippocampus. The anterior cingulate cortex is also implicated in ‘danger avoidance’, whereas the posterior cingulate cortex and the hippocampus form part of a parallel ‘danger approach’ system. Cortical areas work independently of the hippocampus and are thought to be responsible for resolving conflicts between subgoals in the system. In this model, therefore, the prefrontal cortex is seen as being involved in planning rather than forming or resolving goals.

In practice, the model predicts that panic is controlled by the periaqueductal grey matter; phobia by the medial hypothalamus and amygdala; the primary cognitive aspects of anxiety by the SHS; obsessions and compulsions by the cingulate cortex and its interaction with the basal ganglia; and obsessions and pure panic by a dys-

functional periaqueductal grey matter and cingulate cortex, which produce anxiety only if the person has a neurotic personality. The model predicts that high levels of anxiety can produce panic and obsessive behaviour; when the anxiety is less intense, it can inhibit panic (see Figure 12.4).

Gray's model provides a testable and sound basis on which one can attempt to explain the feeling of anxiety. Unlike LeDoux's model, its emphasis is on the response to a conditioned stimulus rather than on the conditioning of the response *per se*. A number of influential theorists in fields such as schizophrenia (e.g. Frith 1992) have adopted many of the postulates of Gray's theory in their own formulations. The advantage of the model is that it makes precise predictions about what happens during the experience of anxiety. Because of this, much of its detail can be supported or disputed. Currently, it stands as one of the most effective models of anxiety in neuropsychology.

Figure 12.4

The role of brain regions in the defence system, according to Gray and McNaughton's (2000) model (original 1.8: from Gray and McNaughton (2000), by permission of the Oxford University Press)

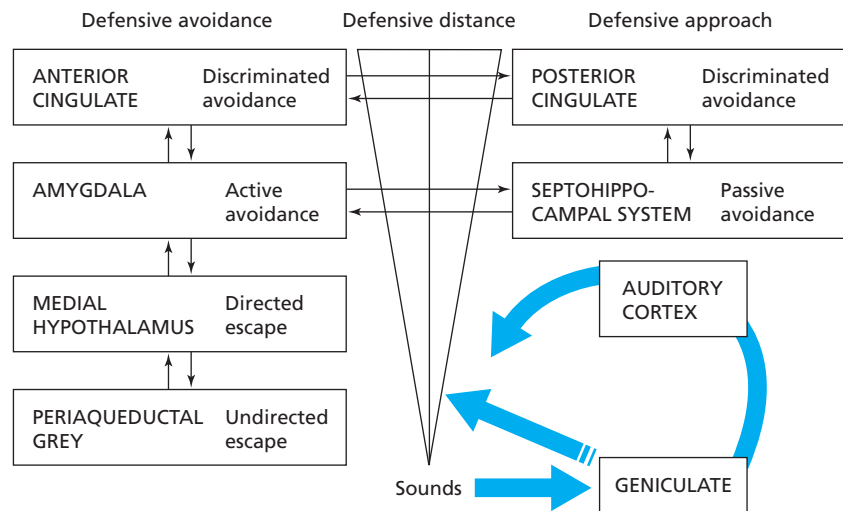

Summary

Schizophrenia is the most challenging and common of the psychoses and is made up of several types. Its most common symptoms are distortion in thought, perception and emotion and bizarre behaviour. Social withdrawal and occupational dysfunction are also features. 22q11 deletion may be a genetic factor implicated in its development. In terms of structure, there seems to be a significant reduction in frontal, temporal and whole brain volume when schizophrenic brains are compared with controls, as well as a decrease in the size of various subcortical structures such as the thalamus and hippocampus. The number of D2 receptors seems to be higher in the brains of schizophrenic individuals. Epilepsy is a brain disorder characterized by seizures. A common consequence of the disorder is memory loss (or failure to consolidate recently learned

material). Emotional disorders are principally of two types: those involving disturbances in affect and those involving extreme responses to threat and stressors. Depression can be unipolar (periods of acute depression followed by normal periods) or bipolar (depression alternates with mania). Brain-imaging techniques have implicated reductions in frontal lobe activation in depression, and limited *post mortem* studies indicate cell loss in the frontal and temporal regions. The most widely accepted pharmacological theory of depression argues that the disorder is produced by a reduction in monoamine neurotransmitters (serotonin, noradrenaline, dopamine). Anxiety, as a clinical term, may refer to specific and social phobia, post-traumatic stress disorder, panic disorder, generalized anxiety disorder and obsessive–compulsive disorder. Each type has been found to recruit different neural circuitry, with some sharing a common circuitry. Gray has proposed that a behavioural inhibition system, mediated by the septum and hippocampal formation, is responsible for detecting and responding to threat. Anxiety reflects the activity of this behavioural inhibition system.

Recommended further reading

Schizophrenia

- Harrison, P. and Roberts, G.W. (2000). *The Neuropathology of Schizophrenia*. Oxford: Oxford University Press.
- Lawrie, S., Johnstone, E. and Weinberger, D. (2004). *Schizophrenia: From Neuroimaging to Neuroscience*. Oxford: Oxford University Press.
- Walker, E., Kestler, L., Bollini, A. and Hochman, K.M. (2004). Schizophrenia: etiology and course. *Annual Review of Psychology*, 55, 401–30.

Depression

- Davidson, R.J. (2000). *Anxiety, Depression and Emotion*. Oxford: Oxford University Press.
- Dawson, G., Frey, K., Panagiotides, H., Osterling, J. and Hessl, D. (1997). Infants of depressed mothers exhibit atypical frontal brain activity: a replication and extension of previous findings. *Journal of Child Psychology and Psychiatry*, 38, 2, 179–86.
- Drevets, W.C. (2001). Neuroimaging and neuropathological studies of depression: implications for the cognitive-emotional features of mood disorders. *Current Opinion of Neurobiology*, 11, 240–9.
- Drevets, W.C., Price, J.L., Simpson, J.R., Todd, R.D., Reich, T., Vannier, M. and Raichle, M.E. (1997). Subgenual prefrontal cortex abnormalities in mood disorders. *Nature*, 386, 824–7.
- Heller, W. and Nitschke, J.B. (1997). Regional brain activity in emotion: a framework for understanding cognition in depression. *Cognition and Emotion*, 11, 5/6, 637–61.

Anxiety disorders

- Cannistraro, P.A. and Rauch, S.L. (2003). Neural circuitry of anxiety: evidence from structural and functional neuroimaging studies. *Psychopharmacology Bulletin*, 37, 4, 8–25.
- Cottraux, J. (2004). Recent developments in the research on generalized anxiety disorder. *Current Opinion in Psychiatry*, 17, 49–52.
- Davidson, R.J. (2000). *Anxiety, Depression and Emotion*. Oxford: Oxford University Press.
- Gray, J.A. and McNaughton, N. (2000). *The Neuropsychology of Anxiety*, second edition. Oxford: Oxford University Press.
- Heller, W., Nitschke, J.B., Etienne, M.A. and Miller, G.A. (1997). Patterns of regional brain activity differentiate types of anxiety. *Journal of Abnormal Psychology*, 106, 3, 376–85.

- Millan, M.J. (2003). The neurobiology and control of anxious states. *Progress in Neurobiology*, 70, 83–244.
- Nemeroff, C.B. (2003). Anxiolytics: past, present and future agents. *Journal of Clinical Psychiatry*, 64, suppl. 3, 3–6.
- Special issue of *Neuroscience and Behavioral Reviews* (vol. 28, issue 3, 2004). Festschrift in Honour of Jeffrey Gray – Issue 1: Anxiety and Neuroticism.

13 Development and recovery of function

- Development and recovery of function: an introduction
- Neural characteristics of development
- Structural development: MRI evidence
- Effect of environment on brain development
- Development of functional asymmetry
- Neuroimaging and development of function
- Recovery of function
- Recovery from aphasia
 - Variables affecting recovery from aphasia
- Sparing of function: some mechanisms
- Some problems with recovery
- Measures of recovery
- Explanations for recovery
- Neuropsychological rehabilitation
 - Rehabilitation of language function
 - Rehabilitation of memory
 - Using compensatory strategies in amnesia
- Summary
- Recommended further reading

Development and recovery of function: an introduction

One of the most intriguing questions in neuropsychology concerns whether the young damaged brain recovers its function better than the adult damaged brain. Tied to this conundrum is the question of how function develops and how this functional development is related to changes in the brain's structure and activity. Several problems are encountered in attempting to solve these problems. The principal problem is that immature brains and adult brains are functionally incomparable. Because adult brains will already have been exposed to a multitude of environmental influences, from visual stimuli to speech, they are already functioning at a fairly sophisticated level. This incomparability in function suggests that the effect of damage seen in children and adults may not be comparable (St James-Roberts 1981). The young child's brain is also a developing brain, and there is evidence of a series of brain growth spurts that makes comparing recovery even of children of different ages problematic. This development is not continuous but occurs in occasional spurts. The first of the major developmental spurts occurs at around 24–25 weeks, when neuronal generation is complete; another occurs in the first year of life,

when dendrites, synapses and myelin are formed and grow; later spurts occur at around seven and nine years; a final spurt is thought to occur between the ages of sixteen and nineteen (Hudspeth and Pribram 1990; Klinberg *et al.* 1999). Some have reported that the most pronounced development occurs five to twenty-one weeks after birth, with adult levels having been reached by six months. The sensorimotor system appears to develop first, with the frontal lobes being last to reach maturity (Chugani *et al.* 1987; Huttenlocher and Dabholkar 1997).

Brain damage may go unnoticed in the immature brain because other brain areas may compensate for the damaged region. Furthermore, as Kertesz (1987) notes, aphasia in children is normally due to trauma or infection, whereas aphasia in adults commonly results from stroke. There are therefore problems in clearly quantifying the developmental effects of brain damage. This chapter considers some of these problems in the context of the mechanisms of brain growth in children and adults and of the development of function. Recovery of function is also an important neuropsychological topic, as is the implementation of a programme of treatment that will facilitate that recovery. Both of these topics are considered in later sections.

Neural characteristics of development

The neonatal human brain weighs about 350 g. By the time it reaches young adulthood, this weight has increased to around 1200–1400 g. By the age of 2 years, the brain will have reached approximately 75 percent of its adult weight (Carmichael 1990; see Figure 13.1). This increase in weight occurs despite the fact that humans are born with all the neurons they will ever get (although see the box ‘Can neurons regenerate?’). The growth that is seen in the first two decades of life after birth is attributable to the growth of neurons, the development of interconnections between them, the proliferation of synapses, the extensive development of glial cells and the myelination of axons, as seen in Figures 13.2 and 13.3.

The growth of neurons is particularly important because, as we saw in Chapter 11, ageing is associated with shrinkage in the cell bodies of neurons, a finding that might be correlated with reduced cognitive and motor functioning in elderly individuals. In addition to neuron growth in the early stages of development, the brain is also thought to undergo some removal of its connective tissue. Processes such as dendrites, for example, may die or decrease in number. This is called pruning. This pruning may also be related to a reduction in connections between cells. One theory argues that we develop an excess of synapses, which are pruned with age because we utilize only some of them; others are redundant. This has been referred to as ‘neural Darwinism’, the notion that the fittest of synapses will survive, whereas the superfluous and unnecessary disappear (Edelman 1989).

The brain exhibits some fairly reliable characteristics of growth during its development. These include cell migration, axonal growth, dendrite formation, synaptic formation or synaptogenesis, and myelination. As neurons migrate to their respective destinations, their axons sprout in a particular direction. The growing end of the axon is called the growth cone and can traverse large distances in the brain in order to reach its desired target. The mechanism responsible for this process is unknown. Axonal growth and extension can be disrupted by blockage resulting from head trauma, poisoning, malnutrition, axonal damage or other factors. When axons are damaged, they might degenerate or move to an inappropriate target. If they do reach inappropriate targets, then the function subsumed by the invaded area may be disrupted.

Figure 13.1

The development of the human brain (from Cowan 1979)

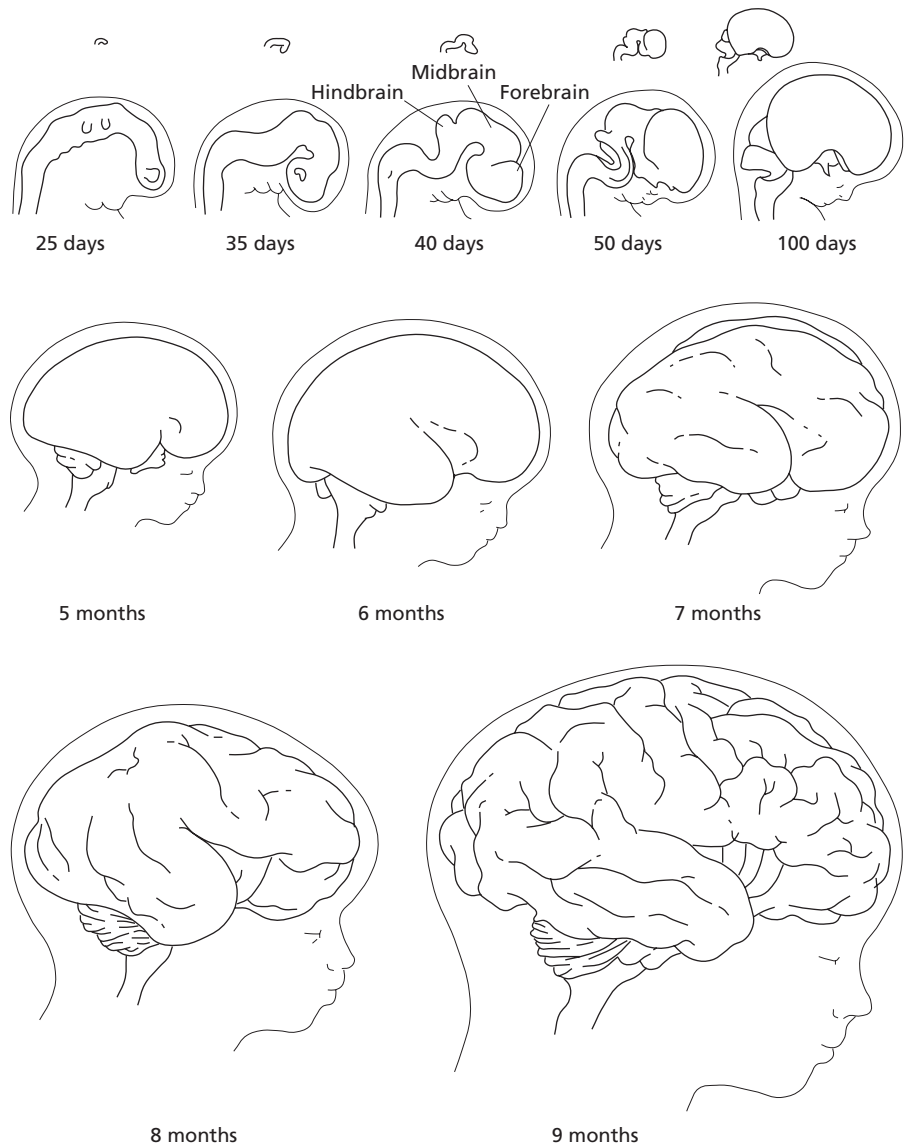

The formation of dendrites begins in earnest after cells have migrated and settled and is timed so that dendrites meet the axons innervating them. Prenatally, there are few dendritic spines; postnatally, they burgeon. It is in fact the loss of these abundant dendrites and their dendritic branches that represents the pruning referred to above. In cases of mental retardation, dendrites may be thinner than normal and have fewer spines or have small spines with short stalks. Complementing the dendritic pruning, and after the prolific development of synapses, is synaptic shedding. Up to the age of 2 years, there is a steady increase in the number of synapses in the young brain. Synapses are made in specific cells in a region – a process that may be genetically engineered or that may be due to the orientation of cells or the timing of the arrival of axons. In the auditory and visual

Figure 13.2

Comparison of (a) the size (from Conel 1939–67) and (b) the weight of the human brain during development (from Dekaban and Sadowsky 1978)

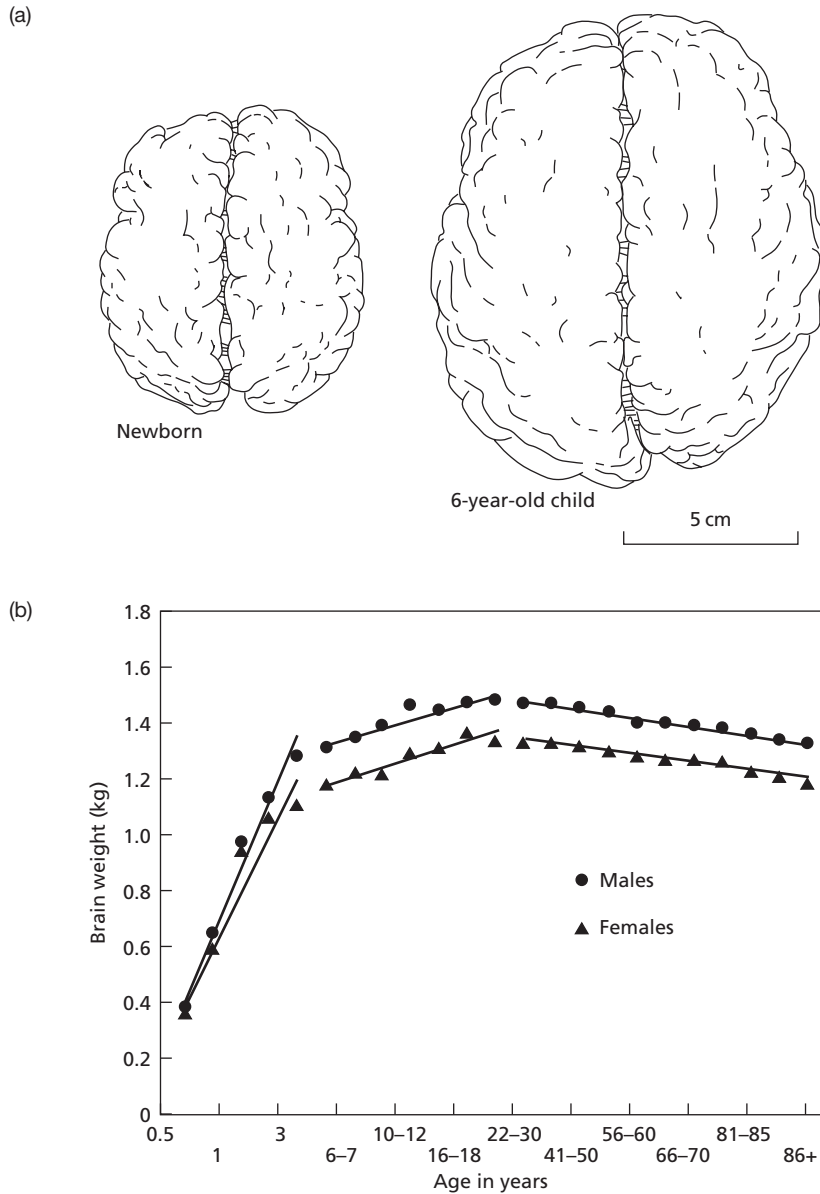

cortices, there is a burst of synaptic development at four months, and in the prefrontal cortex by twelve months (Huttenlocher and Dabholkar 1997). While synaptogenesis is thought to be complete by the age of 7 in the visual cortex, it is thought to continue into adulthood in the frontal cortex. By the time that the brain reaches adulthood, however, up to 50 percent of synapses may have been shed.

Successful myelination, as you saw in Chapter 3, indicates successful structural maturation of the brain. Myelin insulates certain nerve fibres, particularly axons, and neurons are

Figure 13.3

The burgeoning of connections between neurons and their processes from birth to six years (reprinted by the permission of the publisher from *The Postnatal Development of the Human Cerebral Cortex*, Vols. I–VIII by Jess Leroy Conel, Cambridge, Mass.: Harvard University Press, Copyright © 1939, 1975 by the President and Fellows of Harvard College)

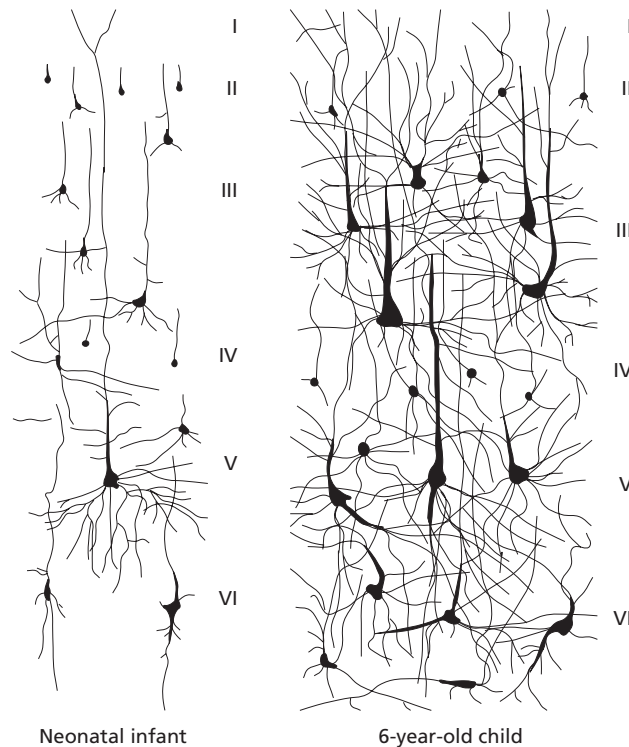

thought to reach maturity when myelination is complete. The process of myelination is thought to begin postnatally, develops rapidly in the first three years, continues to fifteen years and may extend up to sixty years. Once myelination has occurred, the velocity of an axon can increase from 2 to 50 m s⁻¹ (Caesar 1993). However, the primary sensory and motor areas appear to be partly myelinated during prenatal development, but sensory areas appear to be myelinated before motor areas. Myelination of connections between the cerebellum and the cortex occurs only in the second year, with the hippocampus and other limbic system structures continuing to be myelinated into adulthood (Sowell and Jernigan 1998). Myelination in the frontal cortex occurs at ages six and ten and finally in adolescence, a pattern that mirrors the development of skills related to frontal lobe function (Klinberg *et al.* 1999; Levin *et al.* 1991). Chelune and Baer (1986) noted improvements up to the age of fifteen on the Tower of London task. The authors conclude that damage to the frontal cortex in children older than eight will lead to impairment on frontal lobe tests, i.e. those measuring concept formation, planning and strategy shifting. Any disruption of myelination can lead to slowness of response and reduced attention.

Girls tend to show more rapid development of the left hemisphere in early childhood and boys more rapid right hemisphere development, but this pattern is reversed in later childhood (Hanlon *et al.* 1999). Some more specific developmental changes in the brains of boys and girls are described below.

Structural development: MRI evidence

Recent MRI studies have described some of the structural asymmetries that appear during development. For example, the total brain volume for boys was found to be 10 percent larger than that for girls, a finding that was attributable to increased cortical grey matter in boys (Reiss *et al.* 1996). However, the degree of structural asymmetry was similar for boys and girls. Both showed a rightward asymmetry for cortical and subcortical grey matter and left asymmetry for cerebrospinal fluid. These authors also found a significant positive correlation between total brain volume, especially the amount of grey matter in the prefrontal cortex, and IQ.

Similar findings have been reported by Giedd *et al.* (1996). Larger cerebral volume as well as cerebellar volume was found in boys than in girls. Their sample of 104 healthy 4–18-years-olds also showed a larger globus pallidus and putamen in boys and a larger caudate nucleus in girls. The size of the putamen decreased with age. In both sexes, the left lateral ventricles and putamen were larger than the right, which is compatible with the left, asymmetrical CSF volume seen in Reiss *et al.*'s (1996) study. In general, the right hemisphere was larger than the left, although there was considerable variability in the data. This final observation invokes a cautionary warning and one that was mentioned in Chapter 1 when the advantages and disadvantages of brain-imaging techniques were discussed: no two brains are exactly alike. Structural position shows tremendous variability between individuals, even though gross position can be described quite efficiently.

In a cross-sectional study of adolescents (12–16 years old) and young adults (23–30 years old), Sowell *et al.* (1999) reported that in young adulthood, development was localized to the dorsal, medial and orbito-frontal cortex. We know that myelination (covering of axons with myelin) of this part of the brain occurs even into the third decade of life. The results suggest that it is also still maturing in the second decade.

As this study was cross-sectional, there might be differences between the samples (in addition to age) that may account for the differences in maturation. In a longitudinal MRI study of brain development from age 4 to 20, at two-year intervals, Giedd *et al.* (1999) found that white matter increased steadily over time, but the development of grey matter was slightly more irregular. This peaked pre-adolescence and was region-specific. Frontal and parietal lobe development peaked at age 12 and 16, respectively, but occipital lobe development continued to age 20. Although the initial sample was large ($N = 145$), the number of individuals who underwent more than three scans was only thirty-three, which suggests caution in interpreting the results.

Recently, however, a fascinating and ambitious study has mapped cortical development in 5–20-year-olds (Gogtay *et al.* 2004). This study imaged grey matter changes every two years for eight–ten years, and the findings can be seen in Plate 13.1. One of the principal observations is that higher-order association cortices mature after lower-order somatosensory and visual cortices. The regions of the brain considered to be, phylogenetically, the oldest were those that matured earliest (e.g. the entorhinal cortex, piriform cortex). Regions within the temporal lobe were the last to show grey matter maturity. An animated version of the development of these regions can be found at www.Pnas.org/cgi/content/full/0402680101/DC1

Effect of environment on brain development

The nervous system is governed by the environment in which it functions. Stimuli from the external environment help to shape the development of the brain and can help to alter the efficiency of synaptic machinery. This modulation and stimulation of neuronal growth is an important characteristic of brain development. Much of the work in this area had involved depriving animals of environmental stimulation in the first few days of life and examining the effects of this deprivation on subsequent behaviour and brain development.

The well-known Berkeley studies of the 1960s, conducted by Rosenzweig and colleagues, placed rats in one of three conditions: (1) in a standard social condition (three rats in a cage); (2) in an enriched condition (ten–twelve rats per cage with various stimuli to engage them); (3) and an impoverished condition (a single rat in a standard cage) (Rosenzweig *et al.* 1961, 1962). Rosenzweig's studies and those of others (Holloway 1966; Diamond 1967) found that the rats in the enriched condition showed greater enzyme activity and dendritic branching, greater cell body size and a larger number of dendritic spines than those in the other conditions. These changes occurred when rats were exposed to the enriched condition for two hours a day. The results were later extended to cognition; those rats in the enriched condition performed better at tasks of increasing complexity than did those in the impoverished condition (Renner and Rosenzweig 1987). These very controversial and innovative findings gave rise to speculation as to what might occur in human children (and some of the data from such studies is reported in the next paragraph). However, Renner and Rosenzweig (1987) found that the enhanced cognition did not last, and the impoverished rats eventually caught up.

In one non-experimental human study, Skeels (1966) reported that children removed from orphanages and placed in mental institutions developed normal intelligence, whereas those remaining showed evidence of intellectual retardation. The explanation for this difference was that those who had been removed had been exposed to a more intellectually rich environment that would stimulate brain activity. However, the precise mechanism by which the stimulation works is unclear. Several alternative explanations are available: (1) the brain can develop autonomously but requires environmental stimulation to function at an efficient level; (2) the brain develops autonomously until it reaches a point at which it requires stimulation for further development; or (3) the nervous system does not develop all that autonomously but must receive continued stimulation. All these hypotheses are based on the concept of functional validation, the notion that the nervous system requires stimulation during its development in order to become fully functional.

One of the most well-researched areas of brain development in animals has been the development of the visual system. When animals are visually and binocularly deprived by being reared in the dark or having both eyelids sutured, 70 percent of the visual cortex cells have disturbed protein synthesis and fewer/shorter dendrites, whereas deprivation later in development does not produce cell abnormalities. Monocular deprivation, in which a sutured eye will in effect be blind in the few weeks after opening, has long-term effects on normal vision. The earlier the deprivation, the shorter the time needed to bring about the visual abnormalities and the more severe these abnormalities become. There may also be a degree of competition between functioning eyes. An animal with one eye visually deprived for five months will show 31 percent cell response rate when the normal eye is removed, but only 6 percent when the normal eye is present (Kratz *et al.* 1976).

Development of functional asymmetry

The MRI evidence above suggests that the brain develops in an asymmetrical fashion during childhood. There is also evidence to suggest that specific psychological functions are also characterized by milestones in the child's life: functional asymmetry develops only up to, and is complete before, a particular age. Lenneberg, in his well-known book *The Biological Foundations of Language* (1967), argued that functional lateralization of language begins at the same time as the child begins to acquire language and is complete at puberty. This conclusion was based on an earlier study showing that in half a sample of children with right or left brain lesions, language was delayed if the lesion occurred in the first two years of life. The other half of the sample developed language normally (Basser 1962). In adults and adolescents, language difficulties were associated with left hemisphere lesions, whereas mild language difficulties were associated with right hemisphere lesions. Lenneberg thus argued that there was a sensitive period during which language should be acquired and lateralization would develop.

However, these lateralization milestones were challenged by Krashen (1973), who argued that the hemispheres of the brain are equipotential at birth; that is, each hemisphere is capable of undertaking the function for which the other becomes specialized. According to Krashen, the critical period for lateralization is complete by the age of 5 or 6. If lesions to the right hemisphere occur before the age of 5, the child will show aphasic symptoms. If damage occurs after the age of 5, no deficits in speech arise, suggesting that the normal left-for-language functional asymmetry had developed and was relatively complete. Krashen was also involved in the study of an unusual case in which a young girl had been deprived of auditory stimulation and failed to develop normal language. This case is returned to in the discussion point.

The brain lesion and development literature tends to favour one of these hypotheses. In a series of famous experiments, Dennis and Whitaker (1977) and Woods (1980) found that the incidence of aphasia following right hemisphere lesions was greater during infancy than if the lesions had occurred later in life. A more specific timeframe was suggested by Riva and Cazzamiga (1986), who found that language difficulties arose if damage occurred before the age of 1 year regardless of the hemisphere damaged, but only left hemisphere damage was associated with these difficulties if lesions occurred after the age of 1 year. Other authors suggest that left hemisphere lesions would produce the greatest deficits in language and speech if they occurred after the age of 5 or 6 (Vargha-Khadem *et al.* 1985). The reason for this degree of adaptability with youth is that the brain is 'plastic' during its early periods of development. According to Nelson (1999), neural plasticity is 'best thought of as the subtle dance that occurs between the brain and the environment; specifically, it is the ability of the brain to be shaped by experience and, in turn, for this newly remolded brain to facilitate the embrace of new experiences'.

Another source of data suggesting a critical period for the development of asymmetry is found in studies of hemispherectomy, where one hemisphere is removed for medical reasons, usually because of the growth of a large tumour. In adults, left hemispherectomies are reliably associated with aphasia, which is frequently severe (Gott 1973; Searleman 1977). However, left hemispherectomies in children are associated with almost complete recovery of language function (Searleman 1977). The box gives an example of a case of hemispherectomy and its consequences. Non-invasive studies indicate similar developmental patterns of functional asymmetry. For example, dichotic listening studies have shown that the typical right ear advantage for words increases with age (Bryden and Allard 1978), especially between the ages of 5 and 13 (Berlin *et al.*

1973). There also appears to be a difference in the development of asymmetry for different types of auditory stimulus, so that a right ear advantage for the sounds of digits are seen from the age of 4 (Kimura 1963), whereas the typical left ear advantage for the perception of the emotional intonation of sounds becomes apparent at the age of 5 (Saxby and Bryden 1984). The superior right visual field perception of verbal stimuli also occurs at around the age of 4 or 5, with the usual left visual field superiority for facial expression appearing between the ages of 5 and 8 (Broman 1978; Witelson 1977). ERPs on the left are also larger than those on the right when children process language (Segalowitz and Berge 1995).

Given that this evidence suggests that the development of functional asymmetry is fairly complete by the age of 5 or 6 – supporting Krashen's hypothesis – what can we make of the development of other asymmetries that are non-linguistic in nature? Is there evidence of functional lateralization at birth? This question has been prompted and partly answered by a series of different studies in which babies were found to turn their heads more to the right (Turkewitz 1988). Infants were also more likely to reach with the left hand and grasp with the right, the typical hand asymmetry seen in right-handed adults (Ramsay 1980). This asymmetry has been seen in infants as young as two months (Caplan and Kinsbourne 1976). An unusual interaction exists between the child's and mother's behavioural asymmetry: it appears that mothers prefer to cradle their babies in the left arm (Sieratzki and Woll 1996), a finding that the authors attribute to the mother's preference for perceiving the baby's emotional expression via input to the left visual field. This information, the theory argues, is relayed to the right hemisphere, the hemisphere specialized for the perception of emotion. This explanation has not gone unchallenged, however, and lively discussions can be found in Zaidel (1996) and Turnbull and Matheson (1996).

Neuroimaging and development of function

Almost all the studies showing strong evidence for a timetable for the development of functional asymmetry have involved surgery or brain lesions (when not a straightforward description of test performance in healthy children). With the development of fMRI, a technique not available when the most famous studies of asymmetry development were published, investigations have shown how various functions recruit different regions of each hemisphere as children develop (Stiles *et al.* 2003, 2005).

Psychometrically, spatial working memory shows improvement from the age of 4 to adolescence (Luciana and Nelson 1998), 8- to 11-year-olds perform similarly on the tests of mental rotation (Booth *et al.* 2000), and the identification of facial affect is poorer in 11-year-olds than in adults (Thomas *et al.* 2001). Selective attention and working memory continue to develop until the later school years (Barrett and Shepp 1988; Gathercole 1998). Neuroimaging data mirror some of these differences. For example, Thomas *et al.* (2001) found left amygdala activation in adults but bilateral activation in 11-year-olds during the facial affect test, suggesting less differentiation in the children. In terms of language processing, there is a shift away from bilateral activation to left activation. The left lateralization increases with age. Holland *et al.* (2001) found that the left hemisphere was dominant for 7–18-year-olds during verbal fluency performance but that the children showed more right hemisphere activation. Children are also particularly susceptible to interference or failing to inhibit inappropriate responses during psychological

tests. When responses have to be suppressed, children show lower activation in the prefrontal areas typically activated in adults (Bunge *et al.* 2002).

Recovery of function

According to Kertesz (1993), recovery from brain injury follows two stages. In the first stage, the brain recovers from the effects of metabolic and membrane failure, neurotransmission impairments, haemorrhage and oedema (swelling of tissue following injury). Management of the damage is directed towards controlling the oedema. A certain degree of axonal regeneration also occurs immediately after the injury, with new connections developing to replace the old.

The second stage occurs months and even years later, as the brain reorganizes itself: axons regrow, new collaterals sprout, other regions compensate for the loss of the damaged region, and areas surrounding the damage as well as subcortical structures connected to the damaged region help to compensate for the loss. It is this second stage that reflects the patient's functional recovery.

Recovery from aphasia

The most widely studied example of recovery following cerebral injury is recovery from aphasia. Recovery of function is dependent on a large number of variables, including the type of insult giving rise to the aphasia, the age of the patient, the extent of the lesion, the type of aphasia elicited, and patient characteristics such as personality. Most jargon and global aphasia, for example, appears to result from ruptured middle cerebral artery aneurysms (Kertesz 1993). Broca's aphasia or expressive aphasia appears to show the best recovery of all the aphasias (Kertesz and McCabe 1977). In one study, the recovery rates of different types of aphasia were compared (Kertesz and Poole 1974). Global aphasics continued to show severe impairment at follow-up; Wernicke's aphasics continued to use jargon and were characterized by anomia; Broca's aphasics showed a fair to good recovery, whereas conduction and transcortical aphasics showed the most complete recovery. After a period of one year, 40 percent of the forty-seven aphasics had made a good recovery, with 19 percent showing a fair recovery.

Variables affecting recovery from aphasia

The time course for recovery of function is thought to begin in the first two weeks following injury. Greatest recovery is seen in the first few months, with little significant recovery seen after six months and no spontaneous recovery occurring after one year (Kertesz and McCabe 1977). It has been hypothesized that recovery from brain lesions will be better if the patient is young, left-handed, female and intelligent, since any or all of these variables may affect the result of brain damage. Age is the variable that has drawn most attention, not least because of evidence from the studies reviewed above.

Age

The general assumption in developmental neuropsychology has been that the younger the patient, the better the recovery following brain damage (Vignolo 1964). Recovery from aphasia is superior in children if the brain damage occurs before the age of 10–12 (Hecaen 1976). The conventional view of recovery suggests that there are three important periods in recovery: before 1 year of age, 1–5 years, and over 5 years. Lesions before age 5 allow recovery of language function, for example, but those after age 5 do not. Alajouanine and Lhermitte (1965) reported difficulties in reading, writing and speaking in half of a sample of thirty-two 6–15-year-old children with aphasia. One-third of the sample recovered spontaneous language six months after recovery, although others also improved slightly. One year following the onset of damage, twenty-four of the sample had normal or fairly normal language, whereas fourteen continued to show evidence of dysgraphia. Similarly, Woods and Carey (1979) examined the recovery of function in twenty-seven patients who sustained left hemisphere lesions before 1 year of age or at a later age (a mean age of 6 years). Patients were examined ten years or more after injury. Of the eight language tests administered to the patients, only one test (spelling) was impaired in the early lesion patients (compared with normal controls). For later lesion patients, six out of the eight tests (including sentence completion and picture naming) were performed poorly. The two groups showed a similar verbal IQ, which indicates that the general level of intelligence of the two groups did not account for the language impairments.

In an older sample of soldiers who had sustained brain damage, lesions occurring at 17–20 years of age were associated with better functional recovery than those occurring at 21–25 years (Teuber 1975). The latter group, in turn, recovered better than did a group comprising those aged 26 or older. Patients in their 40s and over did not recover as well from posterior temporal speech zone damage as did their younger counterparts.

In an extensive study of fifty patients with pre- or postnatal, left or right hemisphere brain damage, Woods and Teuber (1978) concluded that language survives left-sided damage and argued that this was attributable to right hemisphere compensation. This compensation may occur at the expense of the right hemisphere's visuospatial ability (right-sided lesions produced similar deficits in childhood and adulthood). Woods (1987) has also reported that some functions do not recover. There are deficits in speech shadowing after left and right lesions in childhood and in adulthood, although speech is spared considerably after early left hemisphere lesions. A recent study of patient BL, who underwent left hemispherectomy at the age of 5, reports that standard language tasks were performed well, but there were impairments in decision making involving syntax and prosody (Vanlancker-Sidtis 2004). Consistent with what has previously been reported, the participant performed at normal levels on neuropsychological tests: he was able to pronounce, understand grammar, and understand word and sentence meaning at the levels we would expect of a control participant. However, slight impairments were found on three tests: the patient had difficulty in pronouncing phonemically complex words, comprehending linguistic contrasts in prosody (i.e. understanding the difference in the pronunciation of 'moving van' when the stress is on 'moving' or 'van') and in deciding whether one of two line drawings matched a sentence spoken by the experimenter.

Interestingly, these impairments in prosody did not manifest themselves in the patient's everyday life. He could converse, use humour and take turns when in conversations at a level that belied his surgery. However, the research suggests that although removal of the 'language' hemisphere does not impair most language functions, specific testing picks up

specific deficits. However, the author could not rule out the possibility that the patient was naturally left-handed and therefore had 'right hemisphere' speech. Figure 13.4 shows BL's MRI scan.

Figure 13.4

Axial and coronal views of BL's MRI scans (from Vanlancker-Sidtis 2004)

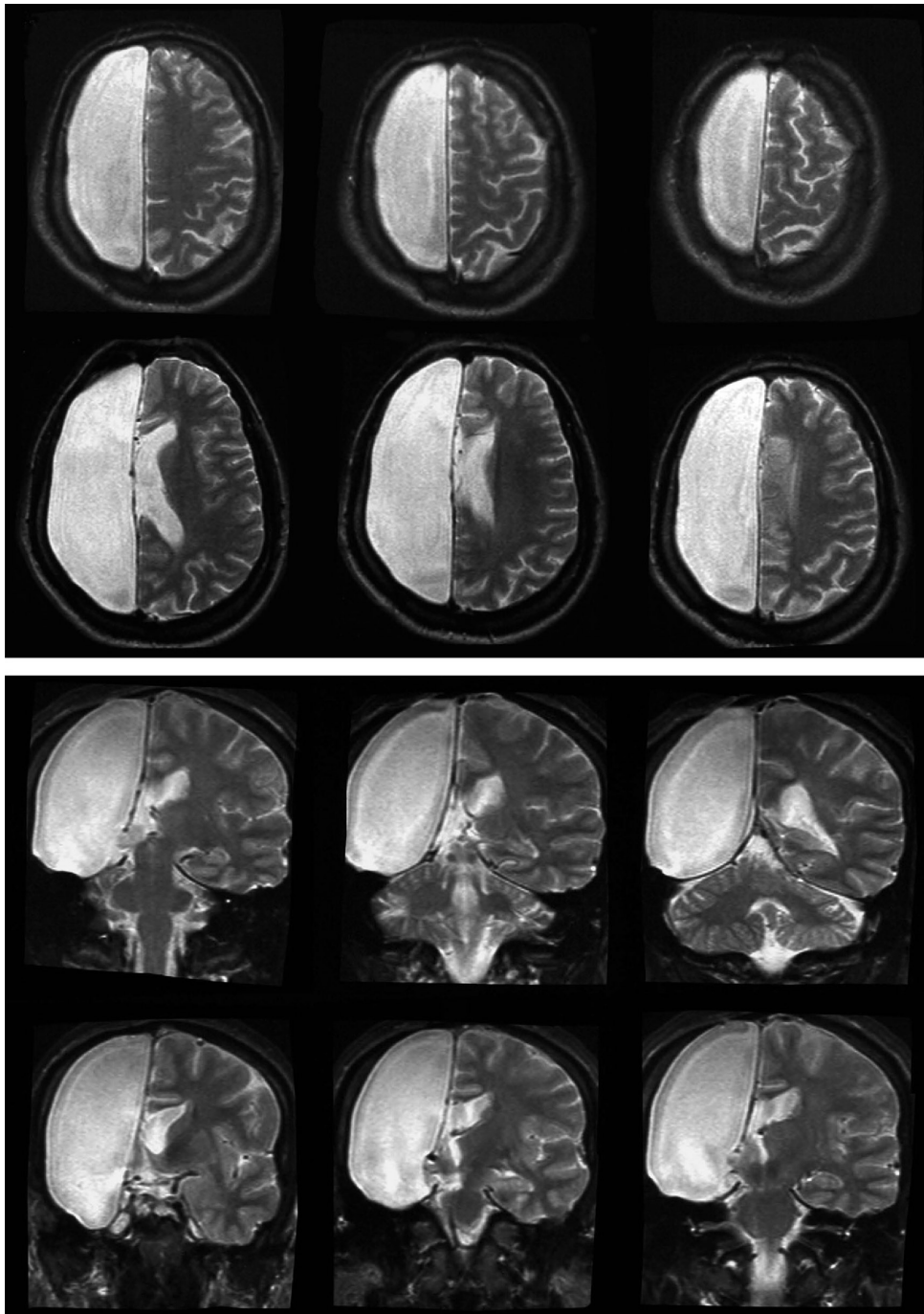

Handedness

Handedness is thought to be an important variable in recovery of function, because left-handers recover more efficiently from brain lesions than do right-handers (Subirana 1969). Presumably, this is because left-handers' language functions are not as clearly or as conventionally lateralized as those of right-handers. There is also evidence to suggest that left-handers are more likely to exhibit aphasia regardless of the hemisphere damaged (Gloning *et al.* 1969). Global aphasics who do not have the typical asymmetry of language function also appear to recover better than those with typical asymmetry (Pieniadz *et al.* 1983), although these results have not been confirmed (Kertesz 1988).

Severity of aphasia

The severity of the initial impairment is sometimes overlooked in studies of recovery. It is certainly an important variable, because if groups of patients are to be compared, they must be initially matched for the severity of their impairment. Severity is a good predictor of later recovery, with severe deficits predicting poor recovery and mild deficits predicting almost complete recovery (Gloning *et al.* 1976).

Type of language function

Different types of language function are likely to recover at different rates and to a different degree than others. For example, impairments in naming, oral imitation and comprehension of nouns appear to be the most long-lasting (Kreindler and Fradis 1968). However, comprehension recovers more efficiently than expressive speech in Broca's aphasia (Kenin and Swisher 1972). Other studies have shown better recovery of grammar and sentence production (Ludlow 1977).

Lesion site

The degree of functional recovery seen following brain injury depends on the part of the brain that is damaged and the extent of this damage. Language is a function that is subserved by many different structures, for example, so that damage to one part may not produce the protracted recovery observed following damage to several parts (Kertesz 1988). In Wernicke's aphasia, the second temporal gyrus, insula and supramarginal gyrus, which surrounds the superior temporal region, are important regions that, if damaged singly, do not affect language as severely as when they are all damaged (Kertesz *et al.* 1989). The degree of atrophy and the size of the lesion are good predictors of successful recovery.

Other variables

Other variables thought to influence recovery are the level of the individual's pre-injury intelligence, health and social status (Darley 1972). However, some studies show no effect of these factors on recovery (Keenan and Brassel 1974). Studies of recovery following head injury have been criticized on methodological grounds. Oddy (1993), for example, argues that a major problem in studies of recovery is the lack of well-designed, well-controlled follow-up studies. In a review of head injury recovery in children, he concludes that children with mild to moderate injuries make an excellent recovery, with few detrimental long-term behavioural consequences. However, he cautions that some cognitive and personality changes may have gone unnoticed owing to design faults in previous studies.

A longitudinal study of full-scale IQ found that this was lower in infants and preschoolers than in adolescents and adults (Anderson and Moore 1995), but while preschoolers showed a similar initial deficit to older participants, they showed less recovery over one to two years (Anderson *et al.* 2000). This pattern was mirrored in the two subscales of IQ – verbal and performance (or non-verbal) IQ. Recovery of verbal IQ performance was not correlated with age of injury, whereas recovery of performance IQ was less pronounced in the younger children (Anderson and Moore 1995) at one and two years following brain injury (Anderson *et al.* 2000). Some aspects of language also fail to recover adequately following traumatic brain injury in childhood. Problems in discourse, especially of a semantic nature, and difficulties in interpreting ambiguous statements and making inferences can continue (Dennis and Barnes 2000, 2001; Barnes and Dennis 2001). Others have found that semantic complexity and fluency in children's narratives were intact following injury, but the narratives themselves were short and impoverished (Brookshire *et al.* 2000). However, injury in the preschool years has been associated with significantly poorer development of discourse than has injury in older children or adolescents (Brookshire *et al.* 2000). The results suggest that certain elements of discourse develop at given periods; if the brain is disrupted during these periods, the specific function associated with discourse is also disrupted. One proposed timetable of developmental change in discourse suggests that this might be so (Chapman *et al.* 1998).

Sparing of function: some mechanisms

In the above sections, we reviewed how damage to the brain early in life can produce severe deficits in linguistic function if lesions occurred after a certain age. If lesions occurred before that time, language developed normally. The earliest systematic, experimental studies of the recovery of function date back to the beginning of the century and the pioneering studies of Margaret Kennard. Kennard observed that unilateral motor cortex lesions in monkeys produced much more severe abnormalities in adults than in infants (Kennard 1936, 1940, 1942). This *sparing* of function in youth became known as the Kennard principle. This principle encapsulates the general belief that early damage is better than late damage. However, in certain examples, early damage results in severe problems. Speech, for example, may survive early damage, but aspects of language processing such as syntax may not.

Recovery of function following brain damage can present problems for an advocate of localization of function, because if an unrelated area of the brain can compensate for a damaged area, then surely this argues against localization of function. Flourens (1824) and later Lashley (1938), for example, argued that it was not the specific area of the cortex that was damaged that was important to loss of function; it was the amount of cortex damaged. However, some areas would need to remain intact for function to be adequate, and an example of this type of cortex would be the primary visual area.

The theory of equipotentiality may explain why early damage to either hemisphere (if it is not too severe) produces no severe long-term consequence in language ability, but it does not explain why damage in young adulthood and beyond produces such severe impairments in language. An alternative view argues that there are redundant parts of the cortex that can be summoned for use if another part is damaged. This is called vicarious functioning (Fritsch and Hitzig 1870; Munk 1881), so called because the undamaged cortex subserves the lost function vicariously. In an excellent test of this hypothesis, Bucy

(1934) performed a series of reverse ablations, destroying those regions that were thought to undertake the function of a damaged part of the cortex. He found that these lesions resulted in no lasting impairment, indicating that these regions were not essential for normal functioning. Other theories of recovery of function are considered below.

Three basic hypotheses explain the sparing of function observed following early brain damage. The invariance hypothesis argues that the left hemisphere shows language specialization at birth and that the right must take over responsibility for language function if the language areas of the left hemisphere are damaged. The second hypothesis, the maturation hypothesis, argues that both hemispheres are involved in language and non-language functions at an early stage but that the left becomes dominant for language. Lenneberg (1967) argued that lateralization of function develops relatively quickly between the ages of 2 and 3–5 and continues to develop until puberty, at which point lateralization is almost complete. He cites the evidence reviewed above, which suggests that aphasia between the ages of 3 and 10 is recoverable because the hemispheres are still not fully lateralized. One hemisphere may then still undertake the function of the other. After the age of 10, recovery would be difficult and after 14 would be poor.

Evidence against right hemisphere acquisition of language ability was reported by Rasmussen and Milner (1975). They found that left hemisphere lesions after the age of 5 did not change speech. They argued that after the age of 6, language ability does not transfer to the right hemisphere but is reorganized intrahemispherically, with undamaged left hemisphere areas undertaking the function impaired by damage to another left hemisphere region. Woods (1980) similarly reported that left hemisphere lesions before the age of 1 year were associated with impairments in verbal and performance IQ, although lesions after 1 year of age were not associated with significant impairment on either measure. Right hemisphere lesions at any age lowered only non-verbal IQ. Furthermore, Woods and Teuber (1978) argue that aphasia rarely results from right hemisphere damage, despite earlier evidence that this form of crossed aphasia did (Basser 1962).

If the invariance hypothesis is correct, one might expect complete removal of either left or right cortex to result in complete immediate impairment in the ability undertaken by the respective cortex. In a well-known analysis of function following right and left hemisphere damage, Kohn and Dennis (1974) found that unilateral hemidecortication (a surgical procedure undertaken to alleviate intractable epilepsy and hemiplegia) resulted in a severe impairment in the function mediated by the removed cortex, although both hemispheres appeared to show some evidence of taking over each other's function. However, it is possible that two of the five left-sided patients could understand reversible passive sentences and one was too young to perform the tasks administered (Bishop 1983). After left hemidecortication, simple language tasks are performed normally, but complex language tasks are not (Dennis and Whitaker 1976). Both hemispheres can produce lists of objects and identify an object from a photograph or description, although the left is better at generating words that rhyme with others. Left hemisphere superiority was found for reading and spelling unfamiliar words, for fluent reading of prose passages and for detecting syntactic errors (Dennis 1980; Dennis *et al.* 1981). Right hemidecortication produced no severe impairment in simple visuospatial performance such as drawing but was associated with complex visuospatial performance impairment such as that found on maze negotiation or map reading.

The third hypothesis, the parallel-development hypothesis, states that the left hemisphere is specialized for language functions and the right for non-language functions. This argues that lateralization of cognitive function (high-level behaviour), such as it is, develops from low-level behaviour that is located in one or other hemisphere.

Some problems with recovery

In their review of mass action and equipotentiality as mechanisms for recovery, Kolb and Whishaw (1987) distinguish between getting better and actual recovery. They propose three criteria for evaluating recovery from cortical damage:

1. Cortical removal should be accompanied by the removal of behaviour thought to be mediated by that part of the cortex. Thus recovery of function following decortication is not recovery in this sense, since the recovery may be subcortical.
2. The recovered behaviour is the same behaviour that is lost. For example, if a cortical lesion abolishes orientation by disrupting eye movement, then recovery owing to the substitution of a head movement is not recovery.
3. If treatment produces recovery, then recovery must be attributable to that treatment and would not have occurred without it.

As we have already seen, recovery of function following brain damage is dependent on a large number of variables. Those thought to *promote* recovery include early lesions, serial lesions, type of pharmacological intervention, environmental treatments and grafts. Apart from the ability of the brain to initiate repair, factors that can *influence the rate* of recovery include type of lesion, locus of the lesion, extent of the lesion, age at which the lesion occurred, individual differences in brain organization, social support, the individual's outlook, and degree of rehabilitation. As a result, the variation in the rate and degree of recovery from brain damage is wide. Levin *et al.* (1982) report that of 1285 patients who sustained closed-head injury and underwent six hours in a coma, 40 percent died. Most of the remaining patients made an adequate to normal recovery. Less than 50 percent of those who did recover returned to work.

According to Miller (1984), a number of assumptions underlie recovery of function. These assumptions are that the recovery curve is consistent and regular, that lesions in younger patients lead to less behavioural disruption than lesions in adults, that over-learned and older skills are less likely to be disrupted by brain damage (logically, therefore, newly learned skills will be more disrupted; this is known as Ribot's law), that more severe lesions will result in a slower rate of recovery, that slowly progressive lesions will present less severe deficits and better recovery, that experience after injury affects recovery, and that intervention or rehabilitation will be more effective the closer it occurs to the time of the injury. These assumptions may be met with qualification.

Recovery normally follows a slow process of a gradual return to function, beginning with the return of low-level behaviour in the early stages and the return of normal function in the later stages. Kertesz (1979), in an analysis of recovery from aphasia, notes that recovery of language after stroke is poor, whereas recovery in head-injured patients is the most complete and rapid. He also found that most of the recovery occurred in the first three months. After six months, very little recovery occurred. As expected, there was evidence to suggest that the younger the patient at the time of injury, the better the recovery. Finally, the aspects of language ability that were fairly resistant to brain damage were naming, oral imitation, noun comprehension and yes/no responses. The sparing of these functions suggests the possibility that perhaps tests of these functions may indicate the patient's level of premorbid intelligence, i.e. will enable clinicians to determine the patient's normal level of intelligence regardless of the brain injury suffered. The problems associated with determining the individual's normal level of functioning before damage are considered in the next chapter on neuropsychological assessment.

Measures of recovery

Although the foregoing evidence indicates the plasticity of the brain and its potential for recovery, little information is available on long-term recovery. However, one factor that might affect long-term recovery is behavioural compensation. For example, Dresser *et al.* (1973) reported that gainful employment was an effective measure of recovery, with 80 percent of their war veterans becoming employed. However, Oddy and Humphrey (1980) argue that employment is not a good measure of recovery: forty-eight of their fifty-four closed-head patients were employed two weeks following injury, but many did not believe that they were working at their best and felt that their activities were restricted.

Often, recovery is measured on batteries of intellectual ability tests, and many of these are described in more detail in the next chapter. Behavioural and sensory/perceptual tests are also used. Teuber's (1975) head-injured war veterans, whose test results in the first week after injury were compared with their test performance twenty years later, recovered some behavioural functions but not others. Over half did not make any recovery; 40 percent made some motor recovery, 30 percent made some somatosensory recovery, and 40 percent made some visual recovery. More than 75 percent did not recover from dysphasia.

Explanations for recovery

Theories to account for recovery have been grouped into three classes: artefact theories, anatomical reorganization theories and functional adaptation theories (Miller 1984), although all three may contain elements of overlap. Artefact theories assume that brain damage results in a primary deficit – a lesion destroys those cells responsible for a particular function and disrupts the function subserved by those cells – and secondary behavioural deficits, seen in a disturbance of functioning of other parts of the brain not involved in the primary deficit. Many physiological changes accompany brain damage, including shock, oedema and reduced blood flow and glucose uptake. Oedema, for example, impairs the functioning of the affected tissue and results in behavioural abnormalities.

The most well-known artefact theory was proposed by Von Monakow (1914), who suggested that when a brain region is lesioned, shock can occur elsewhere either adjacent to the lesion site or at some distance from it. This shock was termed diaschisis and referred to the prevention of innervation by tissue surrounding the damaged region. Accordingly, slow and fast lesions gave rise to serial lesion effects in which sudden lesions would produce more severe deficits than would slow ones, such as those produced by slow-growing tumours.

A similar but alternative explanation was proposed by Luria (1963), who suggested the idea of inhibition, in which primary injury causes an inhibition of other parts of the brain (as seen in synaptic acetylcholine reduction). LeVere (1980), on the other hand, has suggested that one of the effects of brain damage is to move the responsibility of function from the damaged region to an undamaged region. This form of recovery is sometimes referred to as regional or hemispheric compensation. The degree of residual impairment is seen in the difference between the original, damaged system's normal function and the new, compensatory system's attempt at functioning. The two boxes give examples of recovery from aphasia that may involve hemispheric compensation or reorganization of

the cortex. The basis of such recovery is anatomical reorganization: the function of a damaged region may be undertaken by others. It is a rather vague and general principle. Munk (1878), for example, argued that brain regions not remotely connected to the damaged region might take over a disrupted function. However, this suggests that there are brain regions that are not in constant use: an assumption that may not be plausible.

Reorganizing language following brain injury: the case of AA

It is generally agreed that the degree of recovery following brain injury depends on some form of neuronal reorganization, especially when the disrupted function is language. Neuroimaging studies support this hypothesis (Stowe *et al.* 2000; Billingsley *et al.* 2004). What complicates this picture is the age at which injury occurs. There is evidence that the right temporal lobe can take on the disrupted function of the left in infancy (Muller *et al.* 1999), but that the perisylvian region of the right temporal lobe takes over in older children or adults (Stowe *et al.* 2000). Even in these participants, however, there is greater temporal lobe activity in areas analogous to the damaged region (Billingsley *et al.* 2001).

In a novel experiment to explore the nature of plasticity, Hertz-Pannier *et al.* (2002) studied six children who had undergone left hemispherectomy for intractable epilepsy and monitored their brain activity during language tasks before and after the surgery. They hypothesized that if the brain shows evidence of plasticity, then we might expect the right hemisphere to take over the language function of the left. They used fMRI to study the children at age 6 years and 10 months and found the typical left lateralization for language tasks such as word generation; there was little right hemisphere activity.

Following surgery, receptive language recovered quickly, but expressive language and reading were slower to recover. When fMRI scanning was undertaken again at 10 years 6 months, there was a shift in activity to the right hemisphere during expressive and receptive language tasks. The regions that were activated – the inferior frontal temporal and parietal cortices – were analogous to those in the left hemisphere prior to the surgery.

This activation in the right hemisphere is also seen in adults recovering from aphasia. For example, Cappa *et al.* (1997) found that activation in the right temporo-parietal region during the acute phase of recovery predicted improvement in auditory comprehension later on. Musso *et al.* (1999) reported that a period of intensive language comprehension training in a group of Wernicke's aphasia patients led to increased activation in the right superior temporal cortex.

A recent case study suggests that the reorganization may be partial but can occur even after a small lesion (Maestu *et al.* 2004). AA is a 42-year-old right-handed man with epilepsy. The focus was in the left temporal lobe, and surgery was scheduled to limit the disorder. An MRI scan indicated that he had a lesion in the left superior temporal gyrus. MEG was used to localise language functions before and six months after surgery.

AA's receptive language function shifted to the right temporal lobe. Although he had problems with expressive language, his receptive language was relatively unimpaired. Neuropsychological assessment suggested an impairment of visuospatial function, a finding which the authors argue reflects the problem of 'crowding' in the right hemisphere – too many functions undertaken by the same region.

Recovery from aphasia and hemispheric compensation: the cases of HJ, RJ and MJ

Although the mechanisms underlying recovery from aphasia are poorly understood, one view suggests that the undamaged hemisphere assumes the role or function of the injured hemisphere. The idea is not recent. Gowers (1887) reported a patient who became aphasic following a lesion to the left hemisphere. While language eventually recovered, it was lost again following a second lesion to the right hemisphere, suggesting that the undamaged right hemisphere had compensated for the left's loss until it was itself injured.

Some more specific but indirect evidence for hemispheric compensation has been reported by Ansaldo and colleagues (Ansaldo *et al.* 2002a, 2002b, 2004). One of their patients, HJ, was a 50-year-old right-hander who suffered severe aphasia following a left hemisphere lesion (Ansaldo *et al.* 2002a). Over a period of ten months, his ability to perform a lateralized lexical decision task was measured, starting at two months post-injury. A lexical decision task involves presenting words to either the left visual field (the information goes to the right hemisphere) or the right visual field (the information goes to the left hemisphere), and the participant has to make some sort of judgement about them. HJ was asked to respond to high- and low-imageability words and words of different grammatical class (verbs and nouns).

Regardless of class, HJ's right hemisphere was faster at responding to high-imageability words. This advantage was seen at two and four months post-injury, a period in which his language comprehension saw great recovery. At ten months, however, the lateralization effect disappeared, and response times were not significantly different whether words were presented to the left or the right hemisphere.

A similar pattern was also reported in their patient RJ (Ansaldo *et al.* 2002b). She was an 18-year-old who developed Broca's aphasia following a left fronto-temporal haematoma. Followed up over sixteen months using the task administered to HJ, she showed the right hemisphere advantage for high-imageability words at four months and an advantage for low-imageability words at eight months. Her language comprehension improved in this time, but her expression recovered only slightly. One year post-injury, however, the lateralization effect disappeared, and this is when her oral expression also recovered.

A third patient, MJ, was a 52-year-old French-speaking man who developed Wernicke's aphasia following a stroke involving the left temporal and parietal lobes (Ansaldo *et al.* 2004). His auditory comprehension was severely impaired, but he was better at written comprehension. Unlike HJ and RJ, however, MJ showed no hemisphere advantage on the lexical decision task and showed global recovery over time.

What could explain this disparity? One explanation may be found in Castro-Caldas and Bothelo (1980). They suggested that the right hemisphere takes over from the left when the left hemisphere lesion includes pre-Rolandic areas. In MJ, these areas were spared; in HJ and RJ, they were not. The results suggest that, depending on the nature of the lesion, the right hemisphere may compensate for the impairments produced by left hemisphere lesions in the early stages of recovery from aphasia. Particularly significant is that the high-imageability nouns and verbs were those most rapidly responded to by the right hemisphere. The authors suggest that these types of word may be most usefully targeted during speech therapy in the first month post-injury.

The third group of theories, functional adaptation theories, are also based on a general principle: that lesioned individuals may relearn impaired functions by means other than that originally employed (Luria *et al.* 1969). According to Luria (1970), this relearning was capable of enhancing the reorganization of the nervous system. Because this explanation of recovery of function is based on behavioural rather than neuroanatomical mechanisms, psychological factors such as motivation may be important. For example, there is evidence that positive reinforcement helps to alleviate the symptoms of aphasia (Stoicheff 1960).

As a real example of the kind of adaptation that might occur, Miller (1984) cites the knotting of a tie. To begin, one needs to look in a mirror to give visual cues that guide the motor behaviour of actually knotting a tie. With experience, tactile and proprioceptive cues will suffice, without the need for visual cues. In one study of the adaptive competence of eighty-six children with closed-head injury, Papero *et al.* (1993) found that severity of injury had no significant general effect on adaptive behaviour. However, severity significantly affected adaptive (especially social) competence in boys but not girls.

Neuropsychological rehabilitation

One of the important clinical undertakings following the measurement of the effects of head injury is the rehabilitation of the individual's intellectual function. McLellan (1991) has defined rehabilitation as 'an active process whereby people who are disabled by injury or disease work together with professional staff, relatives and members of the wider community to achieve their optimum physical, psychological, social and vocational well-being' (p. 785). One of the most important aspects of care after brain damage is the encouragement of this rehabilitation (Van den Broek *et al.* 1995). Given the correct programme of treatment or therapy, it is anticipated that a patient's functions will be restored more speedily than they would be by spontaneous recovery alone. According to Wilson (1995), the aims of therapy in the rehabilitation of cognitive function are (1) to restore function via anatomical reorganization or restructuring of the environment, (2) to find other ways of helping the patient to achieve a goal, and (3) to encourage the patient to use residual skills effectively. Rehabilitation programmes have been introduced for reading disorders resulting from brain injury (acquired reading disorders) (Patterson 1994), aphasia (Berndt and Mitchum 1995), spatial neglect (Robertson *et al.* 1993) and memory disorders (Glisky 1997).

An important consideration in initiating programmes of rehabilitation is the cooperation of the patient. Successful rehabilitation can occur only if the patient is fully involved and is willing to participate in the programme. Possi and von Cramon (1996), for example, asked 130 patients with mild to moderate brain injury to rate their satisfaction with their rehabilitation programmes. Around two-thirds of the sample were satisfied, but the most severely handicapped were not. Despite the high satisfaction rate, 80 percent desired a greater degree of success in future, and 52 percent had difficulty in accepting their deficits; 77 percent indicated that their quality of life had been reduced following injury, and 52 percent were anxious about becoming reliant on others. These results indicate that patients invest a great deal of importance, time and optimism in the process of rehabilitation.

One type of rehabilitation programme is cognitive rehabilitation, a programme based on principles derived from cognitive psychology and neuropsychology (Parente and Stapleton 1997). In one US survey of rehabilitation programmes, 90 percent of respon-

dents were offered some form of cognitive rehabilitation (Mazmanian *et al.* 1991). In cognitive rehabilitation, the patient is encouraged to engage in two types of activity: (1) 'the reinforcing, strengthening or establishing of previously learned behaviour'; and (2) the establishment of 'new patterns of cognitive activity or mechanisms to compensate' for the impairment (Bergquist and Malec 1997). Cognitive rehabilitation is the dominant form of rehabilitation in neuropsychology and shows consistently successful results in the majority of cases of mild to severe brain injury (Ho and Bennett 1997), even when administered in computerized form (Robertson 1990).

Rehabilitation of language function

One of the more standardized and well-documented rehabilitation exercises concentrates on alleviating the symptoms of language dysfunction, most commonly aphasia (Kertesz 1993). One of the earliest systematic studies of the rehabilitation of language noted that the use of oral drills and cues was associated with improvements in language six months after the initial injury (Butfield and Zangwill 1946). However, a problem with many of the early rehabilitation studies is that they did not appear to consider the possibility of spontaneous recovery (Kertesz 1993). Other studies indicated results similar to those of Butfield and Zangwill. Vignolo (1964), for example, found that therapy was effective two to six months post-injury. Hagen (1973) also found that better speech production, reading comprehension and spelling were associated with therapy. If the therapy is implemented as soon as is practicable, oral expression improves well with treatment, although if the aphasia has been allowed to continue for some time, the therapy is less effective (Basso *et al.* 1975).

Various types of rehabilitation programme can improve language. These involve either structured exercises or less formal and more relaxed procedures. An example of the latter might be the stimulation of the patients' emotional or cognitive functions by encouraging them to talk to others, to form group activities and a good professional relationship with their therapist, or to reinforce responses rather than correcting errors. Programmed instruction involves specific tasks or steps that the patient must complete as part of the rehabilitation programme (Shewan and Bandur 1986). The materials used are similar to those used during the learning of a second language (Kertesz 1993). Other techniques include cueing or priming target words or phrases via structurally or semantically similar words or cues (Huber *et al.* 1991) and encouraging the patient to circumlocute if exact responses are not forthcoming. The idea behind this is that the existing residual communication ability is enhanced. A similar idea lies behind the therapy called PACE (Promoting Aphasics' Communicative Effectiveness), developed by Davis and Wilcox (1981). In this programme, the aphasic patient is encouraged to communicate via any verbal or non-verbal means. A specific example would be asking the patient to describe a picture or photograph that the therapist has not seen.

A recent development in rehabilitation has been the use of computer-assisted therapy. Robertson (1990) has reviewed the effectiveness of computerized cognitive rehabilitation and concluded that specific computerized language programmes and those designed to improve attention assisted rehabilitation, although many programmes did not help the rehabilitation of other functions, such as memory. However, whether these programmes can appropriately encourage normal function in everyday life is questionable. The benefits of computerization are that it is not labour-intensive, and it encourages the patient to behave independently. However, face-to-face contact with the therapist seems likely to enhance conversational language ability and interpersonal skills.

Consequences of hemispherectomy: the case of Jamie

Studies have demonstrated that children who undergo hemispherectomy (usually for intractable epilepsy) emerge relatively successfully from the surgery; they are able to go about their day-to-day routines and to compensate for the functional effects of the surgery with rehabilitation.

One such example is Jamie who, at 4 years and 1 month was referred to clinicians after his operation (Anderson *et al.* 2001). At six weeks, Jamie's parents noticed that he did not look to the right. He later developed infantile spasms, experiencing thirty fits a day in the coming months. At nine months, he underwent hemispherectomy (cortical removal of the left hemisphere), which was successful – the seizures stopped. Although he had reduced mobility in the right leg, he walked independently by the time he was 2 years old. His language development was slightly delayed. He was three of four children; his siblings were healthy.

He was referred to a neuropsychologist because his performance at kindergarten gave some cause for concern. His sustained attention was limited, especially when school activities involved listening (he happily watched television, however), and his memory was poor, especially when having to remember multiple instructions. He also showed unusual language difficulties – he would utter meaningless statements and engage in tangential conversations – and was aggressive and disruptive in class. There was also some evidence of obsessive–compulsive behaviour.

At the time of the assessment, he actively engaged with the tests and was motivated if a little impulsive. Understanding was mixed – excellent and poor by turns – and he sometimes seemed to forget instructions. He scored in the 'low average' range on the Wechsler Primary and Preschool Intelligence Scale – Revised. His comprehension was appropriate for his age, but he seemed to show a lack of understanding of some conversation. When someone uttered a statement and he was asked why the event or person spoken about happened/behaved, he seemed unable to explain. If the question was rephrased, he would do better. His ability to reason was also slightly reduced, and his visuospatial ability was average. Expressive language was intact. Attention problems were evident in tasks that were long and open-ended (he would lose concentration).

On the basis of neuropsychological assessment, the clinicians planned an intervention targeting the attention and verbal reasoning problems, as well as some of the motor difficulties arising from the surgery. For example, they recommended that Jamie sit near the teacher in class so that he would not be distracted by other children and that instructions be given in short sentences that were measured. If he did not understand a sentence, he was encouraged to ask for clarification. Material was made familiar. To help with motor difficulties involved in writing, he would be encouraged to use a word processor when his literacy developed. To assist with Jamie's verbal reasoning deficit, he would be given additional instructions and explanations, especially of complex information. These strategies were found to be successful.

Rehabilitation of memory

Memory is probably one of the most difficult functions to restore and is probably impossible to restore to any normal level of function if the amnesia is severe (Wilson 1991). The principal problems of amnesia involve an inability to learn or retain new information.

The principal problems of rehabilitation are devising programmes that the patient will follow and encouraging patients to use memory strategies spontaneously. Glisky (1997) points out that rehabilitation of memory focuses either on repairing damaged memory processes or on improving memory performance, although the underlying memory ability is unalterable (this latter approach is a little like treating symptoms not causes in medicine). Sometimes, these programmes involve very simple measures such as painting the doors to different rooms in different colours and teaching the patient to associate the different rooms with the different coloured doors (Harris 1980). Other practical steps might be the drawing of lines from one room to another to enable the amnesic patient to get from one place to another.

Using compensatory strategies in amnesia

One of the most effective rehabilitation techniques for amnesia is the adoption of compensatory strategies or external aids that can help patients to remember events, people and appointments. Amnesia can produce an almost total dependence on others, so creating an effective way in which patients can conduct their day-to-day lives is advantageous (Wilson and Wearing 1995). Compensatory strategies have been found to be effective in people with traumatic brain injury (Carney *et al.* 1999) and in patients with severe memory impairment (Kime *et al.* 1996; Evans *et al.* 2003).

Strategies can include either relying on existing, preserved memory ability, using mnemonics or using external aids such as alarms, diaries and Post-It notes. Kime *et al.* (1996), for example, described a 24-year-old woman who developed severe memory impairment caused by epilepsy precipitated by brain damage sustained in a road traffic accident. Her rehabilitation involved maximizing the use of her preserved procedural memory and in adopting external aids such as collecting photographs of her past, keeping an appointments book and keeping a record of the things she had done/was intending to do.

Kim *et al.* (2000) exploited advances in modern technology to investigate rehabilitation in twelve brain-injured individuals. Palmpilot computers were used to help the individuals to organize and plan their lives, and most participants benefited from this technology because it improved prospective memory. Those who found the aid successful continued to use it after formal intervention was over. The authors report that these patients showed a concomitant improvement in self-esteem, anxiety and confidence.

There is good evidence that some people can benefit more than others from adopting these strategies (Wilson *et al.* 1997; Oddy and Cogan 2005). Wilson and Watson (1996), for example, suggest that some predictors of improved memory and the use of memory strategies are being younger than 30, having no significant cognitive impairment (apart from the memory deficit), and having a score of 3 or more on the Rivermead Behavioural Memory Scale (see the next chapter). Evans *et al.* (2003) found that the younger participants in their 94-strong sample used most aids most often. Berg *et al.* (1991) and Kim *et al.* (2000) noted that those with the milder memory deficits were the most likely to benefit. Others have suggested that having at least average or near-average intelligence helps, as well as being able to reason and initiate behaviour and having the ability to show insight into their condition (Giles and Shore 1989).

These last characteristics are illustrated vividly in the two case studies of memory rehabilitation described in the box below.

Overcoming daily memory problems: the cases of JC and Julia C

There are very few case studies of recovery from amnesia, largely because they make depressing reading: progress is slow and laborious. However, Wilson's patient JC and Michael Oddy's patient Julia Cogan are good examples of how rehabilitation strategies can work effectively in reducing problems in everyday life in individuals with severe memory impairment (Wilson 1991, 1995; Wilson *et al.* 1997; Oddy and Cogan 2005).

JC is a self-employed French polisher. During his second year at university, studying law, he suffered an epileptic seizure and collapsed during a tutorial. Five weeks after the episode, he was admitted to a rehabilitation unit for treatment. Doctors, family and friends noted that JC showed severe loss of memory and could not remember anything 'from one minute to the next'. In 1986, he was referred to a neuropsychologist, Barbara Wilson, who began a series of interventions once every two weeks for six months. As Wilson herself notes, however, most of the rehabilitation was initiated, organized and maintained by JC himself.

Wilson's strategy involved having JC use external aids such as using a diary or notebook, using mnemonics and chaining, where tasks are broken down into smaller steps or stages, which can help patients to find their way around when planning short journeys, for example. These benefited JC but were developed by him into a more elaborate strategy: he has been using and refining this strategy for at least ten years following his impairment. In Wilson *et al.*'s (1997) article, JC describes the evolution of his strategy in stages. For example, during stages 1 to 3, he began to use a pocket-book kept in his shirt and used a watch with an alarm that sounded every hour; he would note what he was doing in his notebook when this sounded. He would create weekly and daily sheets on which he would write down all appointments and lists of things to do or done. He bought a dictaphone and would transcribe its contents at the end of every day.

In 1987, he moved into his own flat on the same road as his parents; he removed his old front door key so that he would not return to his parents' home instead of his own. One of his sisters bought him a Filofax, which proved to be enormously helpful in helping him to organize his life. His sisters helped in more than one way. 'In early February, 1988,' he writes, 'I missed an appointment with my youngest sister. She got cross with me to see if this would help. It seemed to have worked as I kept three extraordinary appointments during the week' (Wilson *et al.* 1997: 184).

In 1990, he started a course at Twickenham and Richmond College. He used an A-Z extensively on the bus so that he knew where to get off; by twenty journeys, he knew when to alight without checking his map. He then developed a colour-coded sheet scheme for noting various events: green for anything that needed doing to the flat; red sheets for details of restaurants; pink for miscellaneous; others, which he called 'social sheets' were kept for each of his friends. He would use Post-It notes widely.

During this period, his aunt, Evie Hughes, helped him and made a note of his improvement. For example, she notes how a new watch (the Seiko RC 4000, no longer made) helped JC because it was capable of fifteen programmed weekly alarms and fifteen one-off alarms. He would use the one-off alarms to remind him of individual events. He would role-play some social situations to avoid the embarrassment of not being able to remember in public. He would make a log of all phone calls so that he didn't ring

someone twice with the same message. When leaving his seat on a plane or train, he would repeat to himself the seat's position so that he would be able to return to it.

According to JC, 'I try to make the system foolproof. It's like a web. It's hard for anything to slip through the system. If I miss it with one thing, I'll pick it up with another. I've individualised the system' (*ibid.*: p188).

JC was born in 1965 and, as Wilson *et al.* note, he is obviously intelligent and very well organized, two characteristics that have helped his rehabilitation. The rehabilitation has not been problem-free, however. Despite his efforts, JC does sometimes phone people twice with the same message and continues to wait outside Wilson's old office (and not the one she moved to along the same corridor). Nevertheless, JC's case shows how effective compensatory memory cues can be to motivated individuals.

This success is also seen in Julia Cogan, a 23-year-old with a first-class degree in physics who was pursuing a PhD in neuroimaging and oncology when she suffered a lesion of the left thalamus (Oddy and Cogan 2005). She made a full physical recovery but was extremely disoriented and underwent six months of rehabilitation.

Her everyday problems are familiar ones: she is unable to remember what she had for breakfast, for example, and relies on the strategies she has developed so that she can lead as normal a life as possible. Like JC, she makes extremely good use of her Filofax, and if she cannot remember a piece of information, she can find it quickly in her pad. She also uses mobile phones, personal computers and an electronic organizer but finds that the Filofax is quicker. The pad has extensive notes on people she has met, her travel arrangements, recipes, and so on. If she is asked how work is going, she can flick to a page that describes her last assignment and her next.

Like JC, she is given help by her family in organizing menus, but she has difficulty in remembering use-by dates on food. She also sometimes fails to delete emails and so replies twice. However, her travel arrangements are meticulously planned, and an example is seen in Figure 13.5. Again, like JC, Julia is young, well motivated, intelligent and very well organized. All of these characteristics predictably assist in making the amnesia less of an obstacle.

Figure 13.5

An example of a timetable kept by Julia C (from Oddy and Cogan 2004)

REMINDEES : KEEP TRAVEL PLAN NEXT TO 22nd JULY PAGE IN FILOFAX
 : TICK OFF WHEN EACH LINE COMPLETED
 : KEEP TICKETS IN PURSE.

Travel Plan : DAD MOBILE NO ~~XXXXXXXXXX~~ Date of journey: WED 22nd JUL

if checked, when completed

Checklist	Going from?	Going to?	How?	Leaving at?	Arriving at?	Who?	NOTE	ACTION
BAG	HOME	TW STATION	FOOT	1530 1530	1550 1550	BY MYSELF		BUY RETURN TICKET
1.	TW STATION	TONBRIDGE STATION	TRAIN	1602	1610	BY MYSELF		TONBRIDGE SEAT NO 52
2.	TONBRIDGE STATION	INSIDE DOOR AT TICKET OFFICE	FOOT	1610	1612	BY MYSELF	TO MEET SANDRA	
3.	TICKET OFFICE	CAFE	FOOT	1612	1620	} WITH SANDRA. PHO DAD TO CONFIRM ARRIVAL		
4.	CAFE	TICKET OFFICE	FOOT	1640	1648			
5.	TONBRIDGE STATION	TWELLS STATION	TRAIN	1653	1702	BY MYSELF		1. SEAT
6.	TWELLS STATION	HOME	FOOT	1702	1720	BY MYSELF		MEET SANDRA AT HOME

Discussion point: can a language-deprived child develop normal language after puberty? The case of Genie

On 7 November 1970, the *Los Angeles Times* carried a headline that astonished most of its readers. 'Girl, 13,' it read, 'prisoner since infancy, deputies charged; parents jailed'. The story went on to reveal that the girl's father had harnessed her to a potty in a room in the back of the family house since she was about 20 months old. She slept in a crib covered with wire mesh. Her father was intolerant of noise and would beat her whenever she made any sound. Her mother fed her a diet of baby food, cereals and, occasionally, boiled eggs.

That the child should have been relieved of this horror occurred only by chance. The girl's mother was partially blind, and after a particularly violent fight with her husband, she went with her mother and daughter to the section of the Department of Social Services that dealt with the blind. By accident, she found herself in the Social Services Welfare Department. The social worker's supervisor clearly observed abnormalities in the young girl's behaviour, thinking that she was 6 years old and exhibiting autistic characteristics. The girl was 4½ feet tall and weighed 4 stone. She could not eat solid food and had nearly two complete sets of teeth. She was 13 years and 9 months old.

Apart from her malnutrition and appearance, the most remarkable feature of the young girl's behaviour was her almost complete lack of language. She could not talk and had a vocabulary of about twenty words (she could understand concepts such as red, blue, green). Her speech production was limited to 'nomore', 'stopit' and other negatives. Following her discovery, she was admitted to the Children's Hospital in Los Angeles for treatment.

A young graduate student at the University of California at Los Angeles, Susan Curtiss, was one of the small number of scientists who were able to study the young girl, who was known by the pseudonym Genie, over the next few years. As a linguist, Curtiss was interested in how handicapped Genie's language had become and what possible recovery could be made from such gross linguistic impairment (Fromkin *et al.* 1972/73; Curtiss 1977). Such cases in which one can directly observe the effects of linguistic deprivation rarely occur. Ethically, no experimenter can attempt this. There have been isolated instances of 'accidental' cases, such as Victor, the 'wild boy of Aveyron'. Victor had been found in 1800, lurking naked in front of a cottage in the Languedoc region of France. He had spent his twelve years from infancy living in the woods, surviving on a diet of acorns and potatoes. He had had his throat cut as a toddler and had been left to die. He was subsequently studied and cared for by a young physician, Jean-Marc-Gaspard Itard. Victor had no language, and while he never learned to speak, he achieved a rudimentary ability to spell.

Genie, although not having suffered these misfortunes, had nonetheless suffered misfortunes great enough to make her virtually mute and unable to communicate with others when first discovered. As more became known of Genie's childhood, the more her behaviour became explicable. Her father would not allow a television in the house and abhorred conversation. Genie's room had two windows, both of which were covered. One was kept open a few inches. Genie's malnourishment was remedied, and the girl did not show evidence of brain damage. A year after she was discovered, Genie's language ability underwent marked improvement. Her ability to structure according to rules was the equivalent of a 20-year-old's, and her spatial ability placed

her in the adult ability category. She could tell the difference between singular and plural words and positive and negative sentences and could understand some prepositions. Her speech was limited to one- or two-word sentences, however, eventually becoming very descriptive and concrete ('big rectangular pillow', 'very, very, very dark-green box'). The 'explosion' of language normally expected after such dramatic improvements never materialized.

What does the story of Genie tell us about the critical period of language? It tells us a certain amount but deprives us of much. It became clear that Genie could develop new but basic language skills. She made a dramatic recovery from the time of her discovery to the time when the scientists had to abandon their studies. Yet her language never fully recovered, remaining steadfastly descriptive, almost at the level one would expect primates to achieve with intensive language training. However, her study showed the remarkable, devastating effects of language and auditory deprivation on the development of language ability.

Latest accounts indicate that Genie is still alive and living in a home for retarded adults after her mother had been awarded custody of her. Despite an injunction preventing her from disallowing access to Genie for scientific study, Genie's mother has consistently violated the injunction. Many of the scientists who studied her in the 1970s do not know where she lives and do not know how well she is doing today. Of all the case histories in psychology and in this book, that of Genie is probably one of most tragic, remarkable and yet informative.

Summary

The human brain undergoes considerable development from birth onwards. At birth, the brain weighs approximately 350 g. By the time it reaches adulthood, it will have quadrupled in weight. The reason for the increase is an expansion of neuron size and connective processes. We are born with all the neurons we will ever have. Characteristics of brain growth include cell migration, the growth of axons, the formation of dendrites and synapses, and myelination. A degree of neural pruning occurs in the first few years of life. Excess connections (especially dendritic) become redundant, as do many synapses. MRI evidence indicates that the brain develops asymmetrically, with right hemisphere grey matter being greater than the left and boys showing larger brains than girls. This difference in size continues through to adulthood. Environmental stimulation is important for the efficient development of the nervous system. Deprivation of visual cues early in life, for example, can have detrimental consequences for the development of the visual system. It has been suggested that there is a critical or sensitive period in development during which functions become lateralized. This sensitive period has been described as developing from birth to puberty or, more likely, from birth to the age of 5 or 6, based on studies showing that if either hemisphere is lesioned before this age, recovery of function is relatively efficient. If the left hemisphere is damaged after that age, the long-term consequences for language function are not good, with severe aphasia occurring. There appear to be two stages in the process of recovery: the immediate reorganization of the nervous system after injury and the subsequent development of new connections and compensatory mechanisms. Recovery from aphasia is reasonably good if the patient is young, left-handed, does not exhibit severe aphasia, and the lesion is not extensive and does not involve many important language-related structures. The age of the patient, the

site of the lesion, the type of language function observed and the severity of the aphasia all influence the rate and degree of recovery from aphasia. An important point to remember is that many studies may not be comparable owing to differences in these measures. The sparing of function that appears to accompany early brain damage is an example of the Kennard principle: function may be spared if the lesion is made early in life but may be impaired otherwise. The invariance hypothesis suggests that there is left hemisphere specialization of language at birth and that the right hemisphere takes over this function if the left is damaged. The maturation hypothesis argues that both hemispheres are involved in verbal and non-verbal functions from birth, but that the left hemisphere becomes specialized. The parallel-development hypothesis states that the left hemisphere is dominant for verbal functions and the right hemisphere is dominant for non-verbal functions from birth. The evidence would tend to favour the maturation hypothesis. Theories of recovery argue that (1) damage to one part of the brain can affect the functions of other parts of the brain or that damage to one part might inhibit the activity of another part (artefact theories), (2) undamaged regions not specialized for the function compensate for the impaired function (anatomical reorganization theories), or (3) recovery relies on the adoption of different behavioural strategies to restore function (functional adaptation theories). Rehabilitation refers to the process whereby treatment or therapy encourages the patient to achieve functioning as near to normal as possible. Different rehabilitation techniques are available for language and memory disorders.

Recommended further reading

Development

- Casey, B.J., Tottenham, N., Liston, C. and Durston, S. (2005). Imaging the developing brain: what have we learned about cognitive development? *Trends in Cognitive Sciences*, 9, 3, 104–8.
- Giedd, J.N., Blumenthal, J., Jeffries, N.O., Castellanos, F.X., Liu, H., Zijdenbos, A., Paus, T., Evans, A.C. and Rapoport, J.L. (1999) Brain development during childhood and adolescence: a longitudinal MRI study. *Nature Neuroscience*, 2, 10, 861–3.
- Johnson, M.H. (1997). *Developmental Cognitive Neuroscience*. Oxford: Basil Blackwell.
- Johnson, M.H. and Munakata, Y. (2005). Processes of change in brain and cognitive development. *Trends in Cognitive Sciences*, 9, 3, 152–8.
- Johnson, M.H., Munakata, Y. and Gilmore, R.O. (2002). *Brain Development and Cognition: A Reader*. Oxford: Basil Blackwell.
- Leonard, C.M., Lombardino, L.L., Mercado, L.R., Browd, S.R., Breier, J.I. and Agee, O.F. (1996). Cerebral asymmetry and cognitive development in children. *Psychological Science*, 7, 2, 89–95.
- Maurer, D., Lewis, T.L. and Mondloch, C.J. (2005). Missing sights: consequences for visual cognitive development. *Trends in Cognitive Sciences*, 9, 3, 144–151.
- Nelson, C.A. (1999) Neural plasticity and human development. *Current Directions in Psychological Science*, 8, 2, 42–5.
- Rymer, R. (1993). *Genie: Escape from a Silent Childhood*. London: Michael Joseph.
- Special issue of *Developmental Neuropsychology* on ‘The biological and social determinants of child development’, 2003, 24, 2 and 3.
- Saxe, R., Carey, S. and Kanwisher, N. (2004). Understanding other minds: linking developmental psychology and functional neuroimaging. *Annual Review of Psychology*, 55, 87–124.
- Sowell, E.R., Thompson, P.M., Holmes, C.J., Batth, R., Jernigan, T.L. and Toga, A.T. (1999). Localizing age-related changes in brain structure between childhood and adolescence using statistical parametric mapping. *NeuroImage*, 9, 587–97.

Recovery

- Cappa, S.F., Perani, D., Grassi, F., Bressi, S., Alberoni, M., Franceschi, M., Bettinardi, V., Todde, S. and Fazio, F. (1997). A PET follow-up study of recovery after stroke in acute aphasics. *Brain and Language*, 56, 55–67.
- Dennis, M. and Whitaker, H.A. (1976). Language acquisition following hemidecortication: linguistic superiority of the left over the right hemisphere. *Brain and Language*, 3, 404–33.
- Eslinger, P.J. (2002). *Neuropsychological Interventions*. Hove, UK: Psychology Press.
- Frackowiak, R.S.J. (1998). The cerebral basis of functional recovery. In R.S.J. Frackowiak, K.J. Friston, C.D. Frith, R.J. Dolan and J.C. Mazziotta (eds), *Human Brain Function*. NY: Academic Press.
- Gregor, P. and Newell, A. (2004). *Technology in Cognitive Rehabilitation*. Hove, UK: Psychology Press.
- Isacson, O. and Deacon, T. (1997). Neural transplantation studies reveal the brain's capacity for continuous reconstruction. *Trends in Neurosciences*, 20, 10, 477–482.
- Kolb, B. and Wishaw, I.Q. (1998). Brain plasticity and behaviour. *Annual Review of Psychology*, 49, 43–64.
- Leon-Carrion, D.J., Zitnay, G.A. and von Wild, K. (2005). *Brain Injury Treatment*. Hove, UK: Psychology Press.
- Mimura, M., Kato, M., Kato, M., Sano, Y., Kojima, T., Naeser, M. and Kashima, H. (1998). Prospective and retrospective studies of recovery in aphasia. *Brain*, 121, 2083–94.
- Muller, R.-A., Rothermel, R.D., Behen, M.E., Muzik, O., Manger, T.J., Chakrabarti, P.K. and Chugani, H.T. (1998). Brain organisation of language after early unilateral lesion: a PET study. *Brain and Language*, 62, 422–51.
- Nelson, C.A. (1999). Neural plasticity and human development. *Current Directions in Psychological Science*, 8, 2, 42–5.
- Pizzamiglio, L., Galati, G. and Committeri, G. (2001). The contribution of functional neuroimaging to recovery after brain damage: a review. *Cortex*, 37, 11–31.
- Sohlberg, M.M. and Mateer, C.A. (2001). *Cognitive Rehabilitation*. Hove, UK: Psychology Press.
- Stark, R.E. and McGregor, K.K. (1997). Follow-up study of a right- and left-hemispherectomized child: implications for localization and impairment of language in children. *Brain and Language*, 60, 222–42.
- Stiles, J., Reilly, J., Paul, B. and Moses, P. (2005). Cognitive development following early brain injury: evidence for neural adaptation. *Trends in Cognitive Sciences*, 9, 3, 136–43.
- Vanlancker-Sidtis, D. (2004). When only the right hemisphere is left: studies in language and communication. *Brain and Language*, 91, 199–211.
- Wilson, B.A. (2003). *Neuropsychological Rehabilitation*. Hove, UK: Psychology Press.
- Winocur, G., Palmer, H., Stuss, D.T., Alexander, M.P., Craik, F.I.M., Levine, B., Moscovitch, M. and Robertson, I.H. (2000). Cognitive rehabilitation in clinical neuropsychology. *Brain and Cognition*, 42, 120–23.

14 Neuropsychological assessment

- What is neuropsychological assessment?
- Before neuropsychology: the neurological examination
- Principles of neuropsychological assessment
- Fixed battery versus flexible testing
- The neuropsychological battery
 - Wechsler Adult Intelligence Scales (WAIS; WAIS-R; WAIS-III)
 - Other 'non-neuropsychological' test batteries
 - Halstead-Reitan Battery
 - Luria-Nebraska Neuropsychological Battery
 - Other 'neuropsychological' test batteries
- Individual tests
 - Brief cognitive tests
 - Estimates of premorbid intelligence
 - Reasoning and concept formation
- Memory – the WMS
- Other tests of memory
- Attention and vigilance
- Language function
- Visuospatial ability
- Apraxia
- Practical issues in neuropsychological assessment
- Education
- Choice of test
- Neuropsychological assessment in children
- Assessor-patient interaction
- Patient compliance
- Malingering
- Faults in conducting and reporting the results of neuropsychological assessment
- Computer-based assessment
- Summary
- Recommended further reading

What is neuropsychological assessment?

Perhaps someone with expert knowledge of the human brain will understand my illness, discover what a brain injury does to a man's mind, memory and body, appreciate my effort, and help me avoid some of the problems I have in life.

ZASETSKY (LURIA 1972: 18)

In order to understand and quantify the effects of brain damage on intellectual, motor or emotional function, a clinician administers a set of tests that are designed to measure these effects. This procedure is called neuropsychological assessment and often complements the neurological examination that assesses the patient's central nervous system function and is undertaken by a neurologist. If the neurologist suspects that a patient is exhibiting an impairment in cognitive functioning, he or she might refer the patient to the clinical neuropsychologist for assessment. To observe neuropsychological assessment is to observe neuropsychology 'in action'. According to Crawford (2004), for example, 'Clinical neuropsychologists make a unique contribution to the assessment of clients with neurological or psychiatric disorders. Firstly, they can call on their specialised knowledge of sophisticated models of human cognitive architecture when arriving at a formulation. Secondly, they have expertise in quantitative methods for both the measurement of cognitive and behavioural functioning and for the interpretation of resultant findings' (p. 121).

Neuropsychological assessment might help to determine whether cognitive deficits in an elderly sample are due to progressive dementia or to normal ageing. It might determine whether a patient has visuospatial problems or is aphasic. Apart from providing information about the patient's cognitive ability, the results from neuropsychological examinations can also show the severity and extent of the brain damage and the regions of the brain likely to be damaged. The results of neuropsychological assessment are also used to help to plan the individual's rehabilitation. As you saw in Chapter 13, this is a process whereby the individual is helped to achieve a level of functioning that is as near to normal as is possible via a specified systematic regime of therapy or remediation.

Neuropsychological assessment dates back to the late nineteenth and early twentieth century, when methods for determining the mental capacities of patients with brain disease were developed. Often, these examinations were undertaken in asylums using patients suffering from 'psychiatric' conditions. Later, newly developed intelligence tests began to be applied to patients with brain injury. This work formed the background for the neuropsychological procedures devised after the Second World War. Many of the tests used by neuropsychologists in practice are therefore not designed specifically for neurological patients but for the normal population. This does present something of a problem for neuropsychologists – and is returned to later – but tests are available that are designed specifically for neuropsychological patients. These are evaluated later in the chapter.

Before neuropsychology: the neurological examination

Before the neuropsychological examination, neurological patients undergo a more basic investigation, the neurological examination. The function of the neurological examination is to determine, identify and localize malfunction of the central nervous system (CNS). The process normally begins before the neurologist sees the patient. Usually, a full clinical history of the patient is prepared. This history documents any CNS and behavioural irregularities in the patient's life from the prenatal period to the present. This information can often be found in medical records but is also obtained from relatives or witnesses. According to Barrett (1993), the clinical history provides 'the most important evidence of malfunction of the CNS'. There are several reasons for CNS malfunction. For example, it may be attributable to genetic (e.g. inherited disorders, chromosomal defects), intrauterine (e.g. infections, toxins, malnutrition), perinatal (e.g. premature birth), developmental

(e.g. malnutrition, deprivation, learning disabilities) or adult (e.g. autoimmune degeneration, vascular complications, infection, trauma) problems.

History taking involves the collection of information concerning the patient's family background, such as noting the health of parents or siblings, and life (if there were any delays in literacy; if the patient was exposed to any occupational hazards, e.g. toxins). A history of drug and alcohol use would be considered, as would details of the patient's sexual behaviour and orientation. Finally, details of the patient's medical history and presenting problems such as the duration of the disorder, mode of onset, factors affecting the problem and symptoms associated with the problem, would be obtained.

The types of CNS malfunction likely to appear in the neurological examination range from the simple to the complex. There may be problems with lower-order systems involving sensory or motor impairments or higher-order systems involving impaired cognition and attention. Lower CNS functions include voluntary movement, facial and limb movement, coordination, muscle tone, power, reflexes, sensation and cranial nerve function. Some of these are described below.

Voluntary movement can be assessed by first observing the patient. For example, is the patient's gait disordered or power reduced? Is the patient ataxic, i.e. unsteady, as he or she walks into the examination room? Is the patient shuffling, stiff-legged or limping? More specific procedures include a test of tandem gait, where the patient is asked to walk toe to heel. This determines whether the patient falls to one side or another or whether arm movements are excessive. While the patient is sitting, the examiner might observe asymmetry in facial expression or involuntary movement of the head, mouth, neck, tongue and limbs. Tremor or chorea, for example, are easy to observe under these conditions. The shooting out of limbs (hemiballisms) may also be noted.

Problems with coordination may be largely due to malfunction of the cerebellum. For example, when the patient is required to touch the clinician's outstretched vertical but moving finger and then his or her own nose, 'past pointing' may occur, i.e. the patient will miss the finger. Power might be assessed by requiring the patient to hold his or her arms at right angles so that the arms and shoulders each form an inverted L shape. If the patient is asked to resist when the clinician pushes down on the patient's shoulders but shows no resistance, this may be a sign of motor disturbance. Reflexes may also be tested in a simple way. If the patient's lips are tapped with a vertically held pen and the behaviour elicits a pout reflex, this indicates frontal damage and is considered to be a release sign.

During the neurological examination, the clinician might test for sensory neglect and tactile discrimination in several ways. For example, the clinician might touch the outer side of one or both of the patient's feet or may touch the back of the patient's calves or thighs simultaneously or separately. A mild or developing sensory neglect is indicated if the patient can detect the single touch but not the simultaneous touch. Sensory discrimination can be examined by pressing a blunt or sharp instrument into the skin.

Examination of the cranial nerves might involve the examination of all twelve or a selection of these nerves. Optic nerve malfunction may be examined by moving a vertical finger to the left and right of the midline of the patient's face from a distance of about two feet. A failure of the eyes to track the finger indicates an optic nerve malfunction. A relatively simple test is the examination of pupil size – both pupils should be identical – and their reactivity to light. Hearing can be examined by whispering a digit two feet away from one ear while the second ear is auditorily distracted by an unrelated stimulus, e.g. rubbing of the fingers. Perhaps the most important cranial nerve functions involve the integrity of the visual eye fields and eye movement. These always form part of the neurological examination.

Aspects of the neurological examination are similar to those of the neuropsychological examination – there is a reliance on data from various sources such as observation, test performance, self-reflection from the patient, and information gathered from the patient's family, friends and acquaintances.

Principles of neuropsychological assessment

According to Levin and Benton (1986), neuropsychological assessment has six aims:

1. To identify the presence and type of early or mild disturbance in cognitive function when other diagnostic examinations (e.g. an interview) have failed or their results are ambiguous.
2. To differentiate between brain disease or injury and other factors as causes of cognitive impairment. Depression, for example, can mask the effects of brain damage or may be misconstrued for it if test performance is bad.
3. To evaluate deficits and preserved functions in patients with neurological diseases or injury and to assist in the planning of rehabilitation, e.g. deciding on degree of speech therapy for patients with aphasia.
4. To evaluate the effects of surgical intervention and psychopharmacological treatment, e.g. anti-dementia drugs for Alzheimer's disease and drugs for combating cognitive deterioration in AIDS.
5. To evaluate scholastic problems and developmental delay in children, e.g. to differentiate between mental subnormality, emotional disturbance and specific learning difficulties. However, this is most often undertaken by educational psychologists not neuropsychologists.
6. To provide objective data for research.

As one might gather from the groups normally tested by neuropsychologists and clinical psychologists, there are problems and important practical issues involved in neuropsychological assessment. These include the choice of test, the reliability and validity of the test, the estimation of premorbid intelligence and method of administration. Some of these problems, together with some solutions, are considered in a later section.

Fixed battery versus flexible testing

The selection of a test in neuropsychological assessment may follow two principal routes: the neuropsychologist may either (1) administer a fixed battery of tests where the same comprehensive series of tests (e.g. Halstead–Reitan Battery, Wechsler Adult Intelligence Scale – Revised, Luria–Nebraska Neuropsychological Battery) is given to all patients, or (2) make a flexible selection of tests depending on the reason for neuropsychological assessment. Some of principal tests used in neuropsychological assessment are presented in Table 14.1.

Table 14.1 Some common neuropsychological tests and their uses

Function	Test
General intelligence	Wechsler Adult Intelligence Scale – Revised/III Halstead–Reitan Battery Raven’s Progressive Matrices
Premorbid intelligence	Wechsler Test of Adult Reading National Adult Reading Test Spot-the-Word
Language (general)	Boston Diagnostic Aphasia Battery Multilingual Aphasia Examination Western Aphasia Battery Aphasia screening test of the Halstead–Reitan Battery Verbal IQ scale of the WAIS-R Mill Hill Vocabulary Scale
Language (comprehension)	Token Test Comprehension subtest of WAIS-R verbal IQ
Memory	Wechsler Memory Scale – Revised Memory Assessment Scale Randt Memory Test Warrington Recognition Memory Test Rey–Osteirreith Figure Test Rey Auditory Verbal Learning Test Camden Memory Test Rivermead Behavioural Memory Test
Attention	Arithmetic, digit symbol and digit span subtests of the WAIS-R Seashore Rhythm Test Speech Sounds Perception Test Continuous Performance Test Paced Auditory Serial Addition Test Test of Everyday Attention
Visuospatial ability	Benton and Allen’s Facial Recognition Test Benton Visual Retention Test Visual Object and Space Perception Battery Raven’s Progressive Matrices Ambiguous Angles Test
Apraxia	Florida Action Recall Test Florida Apraxia Screening Test – Revised Test for Apraxia
Reasoning/concept formation	Wisconsin Card Sorting Test Halstead–Reitan Category Test Porteus Maze Test Tower of Hanoi/London task
Handedness	Pegboard task Annett Handedness Questionnaire Edinburgh Handedness Inventory

A neuropsychological test battery has been described variously as ‘a group of related tests combined to yield a single total score that is of maximal efficiency in measuring for a specific purpose or ability or trait’ (English and English 1958) and as ‘a diagnostic set of tests having comparable norms and usually organised in an easily administered series with uniform style’ (Cronbach 1949). Often, a battery is administered together with selected components of other tests. This is called a flexible battery approach to assessment and is the approach adopted by 70 percent of North American neuropsychologists (Sweet *et al.* 2000); 15 percent used fixed batteries, whereas the remainder used a flexible selection of tests.

One of the advantages of a fixed, standardized battery is that one test should be directly comparable with another (Russell 1982). However, a disadvantage is that some batteries do not test some cognitive components, e.g. types of memory. They might also be unnecessarily time-consuming because they involve the administration of tests that may be irrelevant to the problem being examined and can take up to two hours to complete in full. They are also victim to the vagaries of neuropsychology: because new constructs in neuropsychology emerge fairly frequently and batteries take a considerable time to revise, there is often a temporal disparity between what a fixed battery tests and what a clinical neuropsychologist would like to measure.

However, a particular advantage of test batteries is that there is normally a large normative database, a ‘population norm’, which provides a standard with which one can compare an individual patient’s performance. A normative database comprises the statistical features of test performance from a large number of people. The aim is to find the ‘normal’ performance level for each test, hence ‘normative’. The Halstead–Reitan and Wechsler Adult Intelligence Scale III batteries, for example, have large databases of test performance scores for different target populations.

There is a disadvantage to normative databases, however: individuals may not fall within the normal pattern of performance prior to brain damage. In this instance, any subsequent comparison with the ‘norm’ after brain injury is not likely to be informative. In these cases, an estimate of premorbid intelligence, i.e. the individual’s intellectual capacity before the injury, is required. There are some fairly reliable tests of premorbid intelligence for certain groups of patients, and the most effective is described below.

A further disadvantage is that batteries might not take into account what Lezak (1995) describes as contextual factors – the patient’s social history, present life circumstances, medical history and circumstances surrounding the examination. This is a criticism that might also be levelled at some individual tests.

The neuropsychological battery

Wechsler Adult Intelligence Scales (WAIS; WAIS-R; WAIS-III)

The forerunner to the WAIS-III (Wechsler 1997a) – the WAIS-R (Wechsler 1981) – has been described as the ‘workhorse of neuropsychological assessment’ (Lezak 1988), and the latest version looks set to continue this equine slog. It is the single most utilized component of the neuropsychological repertoire and is the most commonly used test of adult ‘intelligence’. It was originally devised as such and not as a test of neuropsychological functioning (the most widely used ‘neuropsychological’ battery is the Halstead–Reitan Battery). There

is a children's version called the Wechsler Intelligence Scale for Children (WISC), and a UK version of the WAIS-III is available, as are Irish, Welsh and Scottish variants. The battery takes between 60 and 90 minutes to complete, but an abbreviated four-test form of the WAIS-III is available (the Wechsler Abbreviated Scale of Intelligence; WASI), which has parallel forms and features different items to those of its parent.

The current version, the WAIS-III, has a widened age range for norms, is culturally up to date and has attempted to reduce floor and ceiling effects by including more easy and difficult items. However, one of its psychometric advantages is that it provides index scores that reflect the battery's factor structure rather than the predetermined allocation of subtests to scales. The battery was validated on 2450 individuals from thirteen age groups (from 16–17 years to 89). It was also administered to African-American and Hispanic respondents, and rarely answered items were removed, thus giving the battery a degree of culture-free face validity.

The WAIS-III comprises fourteen subtests (eleven are included from the WAIS-R):

1. picture completion
2. vocabulary*
3. digit symbol
4. similarities*
5. block design*
6. arithmetic
7. matrix reasoning (new)*
8. digit span
9. information
10. picture arrangement
11. comprehension
12. symbol search (new)
13. letter–number sequencing (new)
14. object assembly.

*From the WASI.

Both the adult and children's versions comprise two major scales: verbal IQ (VIQ) and performance IQ (PIQ), which contribute to full-scale IQ (FS-IQ). Each major scale has various subscales (or subtests). For example, subtests of the verbal scale include tests of:

- information;
- comprehension (practical reasoning/interpretation of proverbs);
- similarities (abstraction and verbalization of properties common to objects);
- arithmetic reasoning;
- digit span (repetition and reversal of numbers presented aurally);
- vocabulary (definitions).

Subtests of the performance scale include:

- digit symbol;
- picture completion (identification of missing features from line drawings);
- picture arrangement (arrangement of cartoon pictures in a meaningful order);

- block design (block construction from a given design);
- object assembly (timed construction of puzzles).

The performance scale of the WAIS-R relies less on the retention of previously acquired information than does the verbal scale. As such, it is less dependent on formal education but is more vulnerable to ageing and conditions that impair perceptual and motor skills and speed (Rao 1986). It is also susceptible to practice effects. The verbal scale is also susceptible but not as susceptible as the performance scale – an improvement of between 2.5 and 8.3 points can be observed, compared with improvement on the verbal scale of between 2.5 and 3.5 points. People score better at the subsequent assessment. Similar points can be made about the non-verbal aspects of the WAIS-III's indices. The WAIS-III tests yield four indices: verbal comprehension, perceptual organization, working memory and processing speed.

The WAIS-R was standardized on a representative sample of 1880 Americans between 1976 and 1980. This version is similar to the original version (Wechsler 1955), but about 20 percent of the content has been updated. The most obvious neuropsychological disadvantage of the WAIS-R is that it is not intended to assess cognitive impairment associated with brain injury, although there is a neuropsychological variant called the 'WAIS-R as a Neuropsychological Instrument' (Kaplan *et al.* 1991). Neither does it take into account factors such as cultural deprivation or emotional disturbance. There are no parallel forms: in order to examine test/retest reliability, i.e. the ability of the test to elicit similar scores on two different occasions, the same tests must be used at the second and first testing sessions, although the four variants of the short form of the WAIS-III have helped to resolve this problem. The WAIS-III and the WAIS-R manuals provide little correction for education and sex. Education accounts for more variance in WAIS scores than does age, for example, especially for the information and vocabulary tests. Age predicts 7 percent of variance in block design test performance, but education predicts 24 percent (see Lezak *et al.* 2004). This said, however, the battery continues to be widely used. It is a relatively well-standardized test, and results are, in general, reliable.

Other 'non-neuropsychological' test batteries

The second most well-known test of cognitive function that was not designed for neuropsychological assessment is the Stanford Binet Intelligence Scale and its variants (Thorndike *et al.* 1987; Roid 2003). The Thorndike *et al.* version comprises fifteen tests, principally for administration with children but which may also be appropriate for adults. These tests include paper folding and cutting, completing the next number in a series, equation building, verbal relations (which of four items is different from the rest) and memory for objects (recall of objects in sequence). The battery was designed to assess four general cognitive areas: verbal reasoning, abstract/visual reasoning, quantitative reasoning and short-term memory. The Roid version measures five factors: fluid reasoning, knowledge, quantitative reasoning, visuospatial processing and working memory.

Halstead–Reitan Battery

The Halstead–Reitan Battery (Halstead 1947; Reitan 1955; Reitan and Wolfson 1993) has a longer history than the WAIS. It originally comprised a series of cognitive ability tests chosen by Ward Halstead of the University of Chicago in the 1930s to determine the

cognitive effects of brain injury. Ralph Reitan applied the tests to psychiatric populations in the 1950s in order to detect brain damage or ‘organicity’, and combined the tests into a battery. The original aim of the tests was to collect research data rather than to assist clinical work. The battery includes six tests:

1. category test (a test of abstract reasoning/hypothesis testing);
2. tactual performance test (the arrangement of variously shaped blocks into holes, without the aid of visual cues);
3. seashore rhythm test (the detection of similarities and differences between rhythms);
4. speech sounds perception test (identification of spoken nonsense syllables from four visually presented ones);
5. finger-tapping test (motor speed test; subject taps a counter with index finger at maximum speed for 10 seconds);
6. trail making.

Tests added to the existing ones include the aphasia screening test, sensory-perceptual examination and grip strength. Performance on these tests is ultimately illustrated by the Halstead Impairment Index, a measure of the proportion of the six original tests passed or failed. This was later superseded by the Average Impairment Index. Although capable of differentiating between neurologically intact and brain-damaged individuals, its ability to discriminate between psychiatric and neurological patients is unimpressive. Individual tests from the battery continue to be used in neuropsychological practice, however, and form part of the Halstead–Russell Neuropsychological Evaluation System (Russell and Starkey 1993), together with the WAIS and the Wechsler Memory Scale.

Luria–Nebraska Neuropsychological Battery

The Luria–Nebraska Neuropsychological Battery (Golden *et al.* 1991) was derived from Christensen’s (1979) text and manual, which were themselves derived from techniques employed by Luria and collected together by Christensen. The tests measure motor, rhythm, tactile, visuospatial, receptive and expressive speech, writing, reading, arithmetic, and intellectual performance (Golden *et al.* 1978, 1980) and were chosen on the assumption that they would distinguish between normal and neurologically impaired respondents. The battery gives rise to five summary scales: pathognomonic, right hemisphere, left hemisphere, profile evaluation and impairment, each of which has its strengths in discriminating between normal and impaired performance.

Problems with this battery include inadequate documentation of aetiology, site and extent of brain damage in the standardization data and the confounding effects of abilities not directly tested by the scales, i.e. tests make demands on other abilities, so it is unclear what ability the test is actually measuring. The verbal bias of the battery also means that its utility in language-impaired patients is limited. There are also time limits on a large number of test items, which means that the quality of the performance cannot be readily assessed (there is no way of characterizing why slow respondents are slow).

Other ‘neuropsychological’ test batteries

Two other test batteries designed specifically for neurological use are the Kaplan–Baycrest Neurocognitive Assessment (Leach *et al.* 2000) and the Neuropsychological Assessment Battery (Stern and White 2003). The former is used to assess cognitive ability and takes

less than two hours to complete. It comprises tests from other sources and assesses attention/concentration, declarative memory, visuoconstruction/visuoperception, praxis, language, reasoning/problem solving and expression of emotion. The latter comprises thirty-six different tests assessing five cognitive areas: attention, language, memory, spatial and executive. Norms are available for the 18–97 age range, and the battery has been standardized on a sample of 1400 individuals. The extensive nature of the battery means that test administration will see little change from four hours.

Other neuropsychological assessment batteries have been designed to assess impairment following specific conditions or illnesses. Examples include the NIMH Core Neuropsychological Battery and Multicentre AIDS Cohort Study Battery (for HIV), and the Agency for Toxic Substances and Disease Registry B, California Neuropsychological Screening Battery – Revised and Pittsburgh Occupation Exposures Test (for exposure to neurotoxins).

Individual tests

In addition to test batteries, neuropsychologists can use a large selection of individual tests tailored to suit a particular behaviour or cognitive domain. These are tests of discrete and specialized function and include tests of memory, attention, visuospatial ability, verbal ability and premorbid intelligence.

Brief cognitive tests

In view of the time-consuming administration involved in battery testing, attempts have been made to construct brief, 10–30-minute tests that assess mental competence. These have been devised largely to assess functioning in the elderly (e.g. Mini Mental State Examination) and to provide a measure of the severity of dementia (e.g. Mattis Dementia Rating Scale). There is only a moderate correlation between Mini Mental State scores and WAIS IQ in neurological patients, however, although the Mini Mental State test continues to be widely used. Items from this test are presented in Table 14.2.

Estimates of premorbid intelligence

Although test batteries have standardized, normative scores that may be used for comparison with an individual's score, there is substantial variation in cognitive ability within populations. If individual difference is great, then a comparison of an individual's performance with the population norm will be unhelpful. For example, a person with an IQ of 130 who sees a reduction in this score after brain injury to 115 would be considered to have above-average intelligence compared with the general population. Compared with the patient's original performance, however, this score reflects a marked decline in intellectual ability. An individualized comparison standard is therefore required (Lezak *et al.* 2004). One method of devising such a standard is to use test scores obtained before the brain disease or damage and compare them with scores obtained after the injury. However, this information is rarely available, for the simple reason that most individuals will not have been neuropsychologically tested before their injury.

Table 14.2 Examples of the type of item seen on the Mini Mental State Examination

Function tested	Item
Orientation	What is the year? What is the season? What is the date? What is the day of the week? What is the month? What city are we in? What floor of the building are we on?
Repetition of the names of three objects	
Attention	Subtraction of 7 from 100 and successive subtraction of 7 from the number remaining Spelling of word backwards
Recall	Naming the three objects uttered by the experimenter earlier
Language	Patient is asked to name objects pointed at by examiner (e.g. a watch, pencil) Repetition of phrases Following a simple written command Copying a design on paper Writing a sentence

An alternative method is to devise a test that estimates the patient's expected or pre-morbid level of performance that is generally impervious to the effect of disease and brain injury. The assumption behind this approach is that a score on one cognitive test will allow the estimation of performance on another. The second assumption is that some tests will be affected by cerebral damage, but others will not. One approach is to take the best performance of the individual, i.e. the best score from a series of subtests, and to use this as the best index of premorbid intellectual functioning (Lezak 1995). However, some subscales of the WAIS-R correlate poorly, e.g. digit symbol and digit span, making the scores derived from these subscales a poor reflection of general premorbid ability.

A solution to this problem is to use a test specifically designed to estimate premorbid intelligence. The most widely used is the National Adult Reading Test (Nelson 1982). This allows a comparison with the individual's obtained Wechsler IQ. There is a short version, which requires subjects to complete only the first half of the test. This version has variable success in predicting full-length NART performance (Beardsall and Brayne 1990; Crawford *et al.* 1991).

The test itself is a single-word, oral-reading test of fifty items. The words are mostly short, correctly spelled but irregular, i.e. they do not follow the normal grapheme-phoneme correspondence rules. The test begins with easier items such as 'debt', 'debris' and 'aisle' and increases in difficulty to items such as 'demesne', 'epergne', 'drachm' and 'talipes'. The short length of the word means that the subject does not have to analyse complex visual stimuli; the irregularity of the words precludes any guesswork. Nelson and O'Connell (1978) have suggested that successful performance on the NART requires previous familiarity with the words but that the test itself makes minimal demands on current cognitive capacity. In order to read the words, the reader must already know them;

using current word knowledge such as the application of grapheme-phoneme correspondence rules will not work.

To be an adequate test of premorbid ability, the NART must be reliable, valid, correlate highly with IQ in the normal population and be largely resistant to the effects of neurological and psychiatric disorder. It has been shown to have high internal consistency and good test–retest reliability (Crawford 1992; O’Carroll 1995). NART scores load heavily on factor ‘g’ in factor analytic studies, suggesting that it is a useful measure of general intelligence. It has been found to predict 55 percent, 60 percent and 32 percent of the variance in WAIS full-scale, verbal IQ and performance IQ, respectively (Crawford *et al.* 1989a). In an American longitudinal study, NART scores predicted verbal IQ scores taken five years prior to patients’ brain injury (Smith *et al.* 1997). There is also (currently unpublished) evidence that it predicts a considerable degree of variance on the WAIS-III (Crawford 2004). Although most research on the NART has concentrated on its ability to estimate general intellectual ability, there is also evidence that it can estimate premorbid performance on more specific neuropsychological tests such as the FAS Verbal Fluency Test (Crawford *et al.* 1992), the Homophone Meaning Generation Test (Crawford and Warrington 2002) and the Paced Auditory Serial Addition Test (Crawford *et al.* 1998)

The first NART study by Nelson and O’Connell (1978) found that a group of forty patients with cortical atrophy were severely impaired on the WAIS relative to a healthy control sample but were no different on the NART. Demographic information was not considered, however. Subsequently, NART performance has been used to compare clinical and healthy subjects matched for demographic variables. Before the development of the NART, the verbal subtest of the WAIS was the most commonly used index of premorbid intelligence. However, the NART is the more resistant of the two to neurological or psychiatric disorder. It is resistant to depression, schizophrenia, alcoholic dementia, Parkinson’s disease (Crawford 2004) and frontal lobe injury (Bright *et al.* 2002; Crawford and Warrington 2002). However, its use with patients with dementia of the Alzheimer type is very mixed (Cockburn *et al.* 2000). Because of potential problems with exposure of single words devoid of context, Beardsall and colleagues (e.g. Beardsall 1998) have developed a version called the Cambridge Contextual Reading Test in which NART words are embedded in meaningful sentences. For example:

The bride was given a beautiful *bouquet* by the courteous groom. They began to walk down the *aisle* as the organist played the first *chord* of the *psalm*.

This variant has been successfully administered to a group of Britons over 70 years old.

However, the NART cannot be used with dyslexic samples or patients with articulation problems (anarthria), for obvious reasons. Also, the NART has been found to decline with cerebral dysfunction, but this decline is overshadowed by an obvious and gross reduction in overall cognitive functioning. If administered within twelve months of traumatic brain injury, there is evidence that the NART can significantly underestimate premorbid IQ (Riley and Simmonds 2003).

The NART appears to be a better predictor of IQ test performance than are demographic factors such as age, sex and level of education. Although there is little difference in their abilities to predict performance IQ – both methods are poor – the NART is better at predicting WAIS and WAIS-R full-scale IQ and verbal IQ (Blair and Spreen 1989). However, the advantage of demographic variables is that they are independent of the individual’s current cognitive state and may be used in groups where the NART would be inappropriate, e.g. dyslexic samples.

Ideally, the best test of the NART's ability to estimate premorbid IQ would be in a context where the patient's premorbid IQ was available. NART performance could then be compared with this premorbid score to assess the test's validity. Moss and Dowd (1991) presented such data from a 29-year-old man, KB, who had sustained severe closed-head injury in a car accident. Fortunately, at the time of follow-up neuropsychological assessment five years after the accident, KB's WISC-R scores were obtained from his old school. Although the NART was standardized against the WAIS and not the WAIS-R (the WAIS yields higher IQs, so the NART should overestimate WAIS-R IQs), the results from KB indicated that the NART estimates were very similar to the WISC-R scores.

In a unique study, Crawford *et al.* (2001) made use of an interesting cultural and historical quirk. In 1932, the Scottish Council for Research in Education decided to conduct a survey of the distribution of intelligence in Scottish children. Crawford and his colleagues used these data to compare the NART scores of a group of 179 77-year-olds with the same participants' IQ records obtained when they were 11 years old.

A strong and highly significant correlation was found between NART performance at age 77 and IQ performance at age 11, a correlation that was higher than that between current IQ and current NART performance, and between current and past IQ performance. The finding is remarkable because, as the authors argue, we might predict that 'any relationship between these two variables [NART and prior IQ performance] would have been severely attenuated by individual differences in exposure to a myriad of environmental factors in the intervening 66 years'.

Reasoning and concept formation

Perhaps the most common test of abstract reasoning and cognitive flexibility is the Wisconsin Card Sorting Test (WCST) described in Chapter 5. Milner (1963) found consistently poorer performance in patients with frontal dorso-lateral excisions than in non-frontal lobe patients. The relationship between frontal lobe damage and WCST performance is ambiguous, however. Some frontal lobe patients perform more poorly than non-frontal patients; others do not (Drewe 1974; Heaton 1981). Other studies have indicated no significant difference in performance between frontal and non-frontal patients (Grafman *et al.* 1990; Anderson *et al.* 1991).

Frontal lobe patients have been found to fail on the Porteus Maze Test, which taps the capacity to inhibit immediate responses in favour of deliberation. Patients are normally impulsive and break rules. It is sometimes the case that frontal lobe patients will perform at a normal level on other tests but show failure on the Porteus Maze Test.

Memory – the WMS

Tests of memory assess both long-term and short-term components, recognition and recall (immediate and delayed types) and can come as batteries or as individual tests. The Wechsler Memory Scale (Wechsler and Stone 1974; Wechsler 1997b) is a battery of memory tests that is currently in its third incarnation (WMS-III). In its early guise, a collection of subtests yielded a Wechsler Memory Quotient (WMQ), but subsequent revisions did away with this unitary quotient because it was not seen as particularly useful. The revised battery also included assessment of visual and non-verbal memory,

measures of delayed recall and the inclusion of adequate norms. There is only one form of the battery, and the WMS-R comprises nine tests, which include:

- Information and orientation (e.g. ‘what is your age/date of birth?’ ‘Who is this [famous figure]’?).
- Mental control (e.g. automatic speech such as recitation of the alphabet).
- Figural memory (e.g. immediate recognition of abstract objects).
- Logical Memory I and II (e.g. immediate and delayed recall of short stories).
- Visual paired associates.
- Verbal paired associates.
- Visual reproduction I and II (e.g. immediate and delayed recall of drawings).
- Digit span and visual memory span (e.g. memory for strings of digits recalled forwards and backwards and a non-verbal analogue).

Scores from the tests contribute to five indices: verbal memory, visual memory, general memory, attention and concentration, and delayed memory. The WMS-III revision comprises six core tests (three of which appear in the WMS-R) and five more that are optional (four are variants of WMS-R tests). The core tests are logical memory, verbal paired associates, spatial span, letter numbering and sequencing, and faces and family pictures. The optional tests are information and orientation, mental control, digit span, visual reproduction, plus a new test, word lists. Visual paired associates and figural memory do not feature. Almost all the tests come in immediate or delayed recall formats and now have norms for individuals in the 85–89 age range (the previous edition’s oldest age range was 70–74).

These tests generate eight indices: auditory immediate, visual immediate, immediate memory, auditory delayed, visual delayed, auditory recognition delayed, general memory and working memory. The General Memory Index is calculated based on scores from the delayed variants of the core tests. Moderate to severe traumatic brain injury can lead to impairment on almost all tests (the least reliable index appears to be the auditory recognition delayed index).

Other tests of memory

Various other memory batteries and individual tests exist, including the Camden Memory Tests, the Memory Assessment Scales and the Rivermead Behavioural Memory Test. The Camden Test (Warrington 1986) comprises five tests in which stimuli are presented for three seconds each and immediate recognition is measured. The Pictorial Recognition Memory Test of this portfolio features colour photographs of distinctive objects; the Topographic Recognition Memory Test uses colour photographs of places. The Randt Memory Test (Randt and Brown 1986) provides a longitudinal assessment of patients with memory storage or retrieval problems using seven subtests. Williams’s (1991) Memory Assessment Scales (originally, the Vermont Memory Scale) assesses attention and short-term memory, learning and immediate memory and delayed memory and comes in verbal and non-verbal variants.

The Rivermead Behavioural Memory Test (Wilson *et al.* 1985, 1999, 2003) is different to standard tests of memory because its principal concern is with the practical conse-

quences of memory impairment. Thus tests measure the ability to remember a name associated with a photograph; where an experimenter has hidden an object; an appointment or a newspaper article; a new route; to deliver a message; to name the day and date; and to recognize pictures. The test, which has four parallel forms, yields a Total Memory Score. The original incarnation was criticized because its scoring range (2–3) was too limited and therefore provided no sensitivity at the highest or lowest ends of memory functioning (Leng and Parkin 1990): patients with mild traumatic brain injury, for example, performed at perfect levels on many tests, although patients with more severe damage could be discriminated using the tests. A revised version (Wilson *et al.* 1998) is available that assesses more subtle memory impairments: the amount of material to be remembered has been doubled, and a five-point scoring system is included. This revision has been found to be sensitive to Parkinson's disease, ageing, stroke, dementia and Alzheimer's disease. Tests of prospective memory (see Chapters 5 and 9) also tap a similar practical vein in that they measure a patient's ability to remember to behave in a specific way at a given time (e.g. taking a pill at a certain time of day). One such test is the Prospective and Retrospective Memory Questionnaire (see Crawford *et al.* 2003; Crawford *et al.* in press).

The Recognition Memory Test (Warrington 1984) comprises two tests assessing recognition of words and faces in individuals aged between 18 and 70. The words are one-syllable and high-frequency and are presented in a booklet, one page at a time. The faces are of men with the clothing below the neckline visible. The latter task seems to be sensitive to right-sided lesions, whereas both tests are sensitive to left-sided damage (Warrington 1984; Sweet *et al.* 2000), although left-lesioned participants score better on the faces version, possibly because visual cues are (other than the faces) present in the booklet (the clothing). Some have suggested that the test is more appropriately administered to individuals with mild memory disorder (Leng and Parkin 1990).

Other tests measure the ability to remember or recognize visual information. The Continuous Recognition Memory Test (Hannay *et al.* 1976) presents 120 line drawings of flora and fauna (e.g. flowers, cauliflowers, dogs) to participants, who later attempt to recognize them. An analogue exists for abstract figures (the Continuous Visual Memory Test). Perhaps the most well-known test of visual recall is the Complex Figure Test or the Rey–Osterrieth (Rey 1941; Corwin and Bylsma 1993), which can be seen in Figure 14.1(a) and (b).

The figure was originally devised by André Rey to examine visual memory in the brain-injured, but the procedure for the test was developed more comprehensively by Osterrieth (hence Rey–Osterrieth, or Rey–O). In the test, participants first copy the figure, then either immediately or after a delay attempt to draw the figure from memory. An alternative version was developed by Taylor (1979) and modified by Hubley and Tremblay (2002) that involved reducing the number of distinctive features. This version is easier to recall than is the Rey–O. The Medical College of Georgia Neurology Group has also developed its own complex figures.

Students who report adopting a 'visual' strategy when recalling the figure recall it more accurately than do students adopting a 'verbal' strategy – these students recall the Rey–O more accurately (Casey *et al.* 1991). Accuracy of recall appears to be age-dependent, with performance falling from the age of 30 to 70, when there is a steeper decline (Spreen and Strauss 1998). Those patients with damage to the right hemisphere are known to omit elements of the figure and generate poor reproductions.

The Benton Visual Retention Test also involves drawing/copying and recall of stimuli. Stimuli are presented on a card for ten seconds, and immediate or delayed recall by drawing is requested. An example can be seen in Figure 14.2. Recall problems normally include omitting, distorting, rotating or misplacing elements (putting one element of the

Figure 14.1

(a) The Rey Complex Figure; (b) the Taylor Complex Figure and Modified Taylor Figure variants (from Lezak *et al.* 2004)

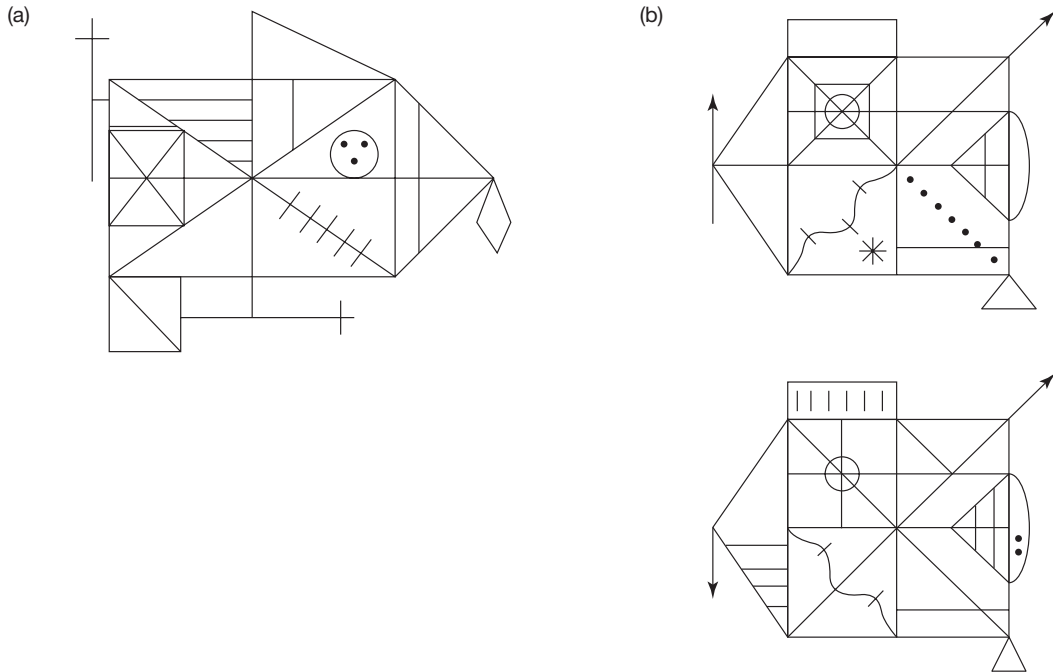
**Figure 14.2**

An example of the Rey figure (a) copied, (b) drawn from memory after three minutes and (c) drawn from memory after 40 minutes (from Lezak *et al.* 2004)

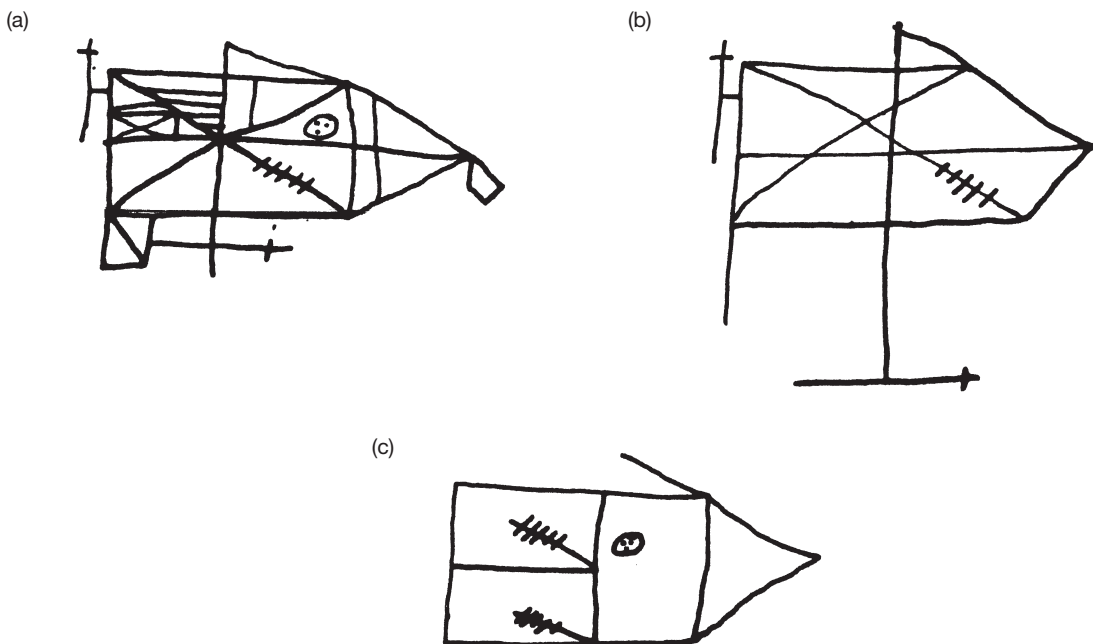

ensemble where it does not belong) perseverating, or reproducing elements of the wrong size. Distortion is the most common error in the over 65s (45 percent), followed by rotation (Eslinger *et al.* 1988), and impaired performance is characteristic of the early stages of Alzheimer's disease (Storandt *et al.* 1986).

Finally, there are memory questionnaires that note the patient's day-to-day impairment and how the patient views his/her functioning. These phenomenological observations can be compared with the patient's documented (assessed) memory impairment. Examples include the Memory Functioning Questionnaire, the Inventory of Memory Experiences, the Subjective Memory Questionnaire and the Memory Assessment Clinics Self-Rating Scale. These questionnaires can be used to supplement the quantitative data obtained from neuropsychological testing, thereby providing a more complete neuropsychological portfolio of a patient's behaviour.

Attention and vigilance

As we saw in the section on neurological examination, attention may affect performance on tests that do not examine it directly. This is important to consider because, as noted above, a patient unable to pay attention to a task will perform badly on almost any other test that the neuropsychologist administers. Learning and memory tasks, for example, may be particularly affected by attention deficits. There is no battery of tests to examine attention explicitly, and the tests used in the neurological examination are fairly simple. As a result, neuropsychologists have administered tests that were designed for other purposes: tests such as the arithmetic, digit symbol and digit span subtests of the WAIS-R. The Seashore Rhythm Test and Speech Sounds Perception Test from the Halstead-Reitan Battery are also thought to be adequate measures of attentional deficit.

The Continuous Performance Test is one of the few tests explicitly assessing degree of attention. This test requires the patient to respond only if a particular letter is present in a series of letters or if a letter follows another specific letter. Performance on reaction time tasks may also be a useful measure of attention if the neuropsychologist requires an assessment of the patient's ability to return to a workplace that demands constant alertness from the subject. Another test that measures sustained attention is the Paced Auditory Serial Addition Test. For this test, the subject is required to add a series of sequentially presented numbers. For example, a 3 followed by 6 becomes 9, followed by 5 becomes 14, and so on. A specific test of attention that can be applied in more ecologically valid contexts, the Test of Everyday Attention, has been developed with quite good validity and reliability (Robertson *et al.* 1994, 1996; Crawford *et al.* 1997).

Language function

The most common language difficulty in neurological patients is anomia, a popular measure of which is the Boston Naming Test (Kaplan *et al.* 1983). Other standardized aphasia test batteries measure such aspects of language function as fluency and repetition. These include the Boston Diagnostic Aphasia Battery, the Multilingual Aphasia Examination, the Western Aphasia Battery and the Aphasia Screening Test of the Halstead-Reitan Battery.

According to Lezak *et al.* (2004), the assessment and diagnosis of aphasia involves measuring the following abilities: spontaneous speech; repetition of words, sentences and phrases; speech comprehension; naming objects or pictures; and reading and writing. In order to be classified as aphasia, the disorder must not be sensory or motor in nature (e.g. language difficulty produced by muscle paralysis or deafness), and the patient must have some deficit in the comprehension, repetition or production of meaningful speech.

Two approaches can be taken when assessing aphasia: the screening approach and the more detailed test battery approach. The screening approach involves the rudimentary evaluation of the patient for signs of the disorder. Two tests are sometimes used: the Halstead Screening Test and the Token Test-R. In the Halstead Screening Test, the patient is asked to complete a series of ostensibly simple exercises such as naming common objects, spelling words, reading, writing, enunciating, identifying body parts, performing mental arithmetic, distinguishing left from right and copying simple geometric shapes. This is a relatively easy screening test to administer and gives the clinician an initial idea of the severity of the patient's language problems.

The Token Test presents the patient with twenty tokens that vary in shape (e.g. a square or a circle), size (big or small) and colour (red, yellow, green, blue or white). In the full version of the test, the patient is given sixty-two oral commands to follow, such as 'place the white square underneath the red circle'. The test's ability to distinguish aphasic patients from controls is excellent, with one study showing that it could do this in 90 percent of cases (Boller 1968). It is also more sensitive at detecting aphasia than is simple clinical observation. A shorter version (thirty-nine commands) is available.

A more detailed assessment of aphasia is provided by specifically developed test batteries. The most widely used is the Boston Diagnostic Aphasia Examination (Goodglass and Kaplan 1972). This aims to diagnose aphasia and its types as well as providing some guidance for rehabilitation. The tests in the BDAE are divided into five sections:

1. conversational/expository speech;
2. auditory comprehension;
3. oral expression;
4. understanding written language;
5. writing.

The test is useful because it provides a qualitative assessment of language difficulties and is designed to allow differential diagnosis. It has standardized data with which to compare patient performance, and it is comprehensive.

A test that measures behaviour not touched on by the BDAE is the Communicative Abilities in Daily Living Test (Holland 1980). As the name suggests, this test requires the patient to produce or comprehend speech in a variety of everyday real-life contexts. For example, the patient may be asked to role play a visit to the doctor's or the local shop. This can help to identify more social and genuinely communicative language problems.

Visuospatial ability

Visuospatial function can be assessed in a variety of ways. There are tests of complex visual discrimination, meaningful integration of visual information, discrimination of background and foreground, and identification of objects that are at odd or ambiguous

angles. Tests might involve copying a drawing or figure or copying this figure from memory. Individuals with right temporal lobe lesions, for example, perform poorly on visual form discrimination tests, whereas right hemisphere/bilateral lesions are associated with impaired discrimination of familiar faces (Benton and Van Allen 1968). Tests of facial recognition include those of Benton and his colleagues (1983). In the full form of the test, the subject has to identify a target face from photographs of (1) six face-forward faces, (2) six three-quarter faces or (3) six faces under different lighting conditions.

Progressive matrices (usually known as Raven's Progressive Matrices) require the patient to indicate which stimulus from a selection of stimuli would correctly complete an incomplete pattern. The matrices are called progressive because this task becomes progressively more difficult with each subsequent pattern. Posterior lesions of either hemisphere are associated with deficits on this task. Performance on the progressive matrices test has been used as an estimate of intellectual ability, although the modest correlation with the WAIS suggests caution. Examples of visuospatial test items can be seen in Figures 14.3, 14.4 and 14.5.

Figure 14.3

An example from the Raven's Progressive Matrices (from Blair *et al.* 2005)

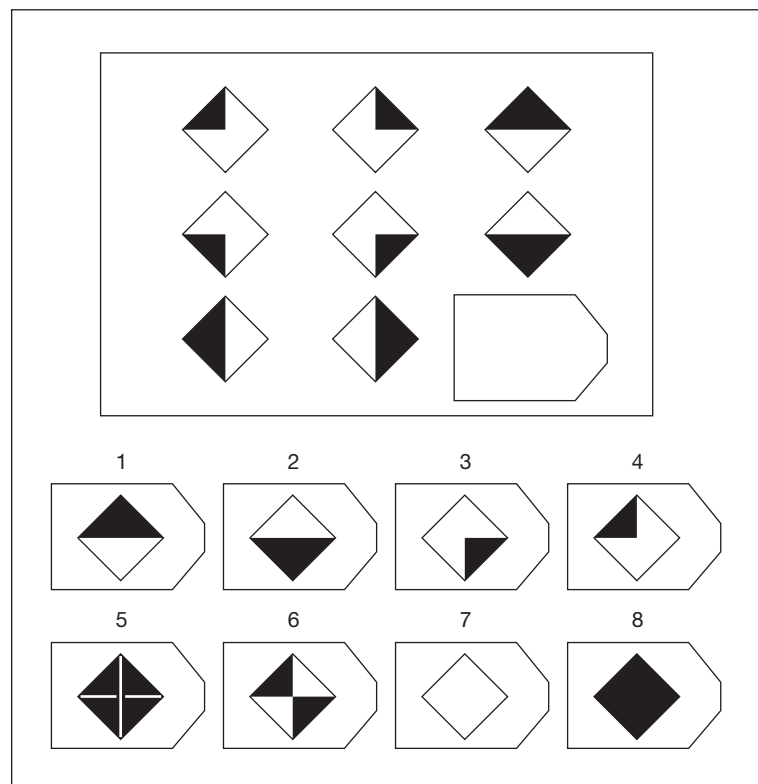

Figure 14.4

The line orientation test: which numbers match the lines above?

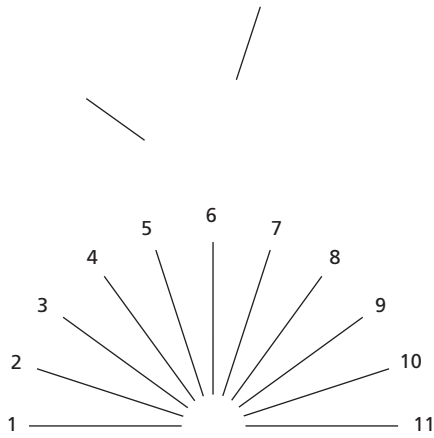
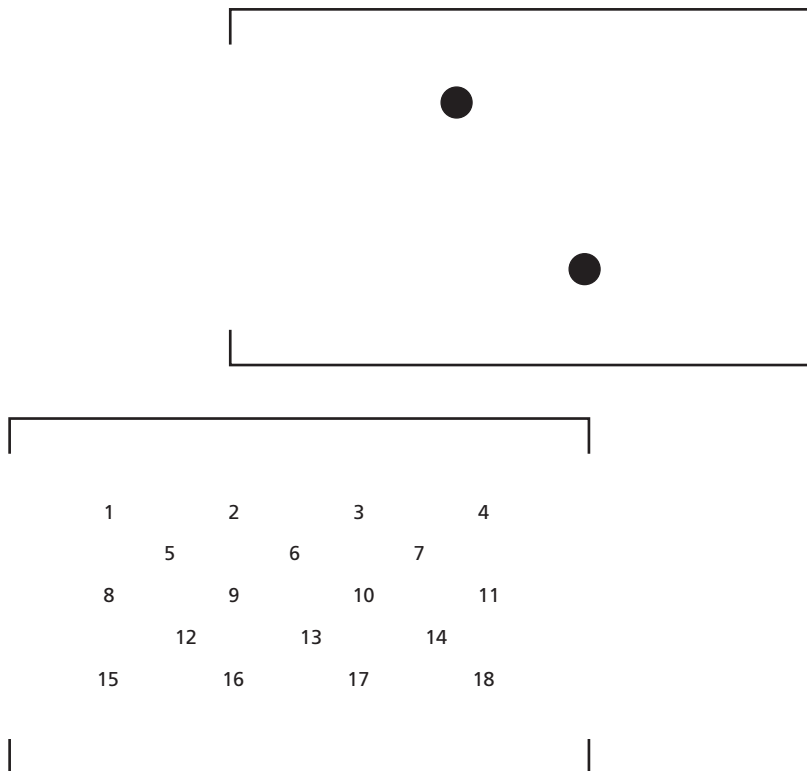

Figure 14.5

The dot localization task: which numbers represent the positions of the dots? (adapted from the Visual Object and Space Perception Battery)



Apraxia

Tests of apraxia normally involve asking the patient to mime the use of an object in the presence of that object, to mime the use of an object by physically manipulating it, to mime a gesture, or to perform a series of motor acts that encompass one general instruction (e.g. making a cup of tea or brushing one's teeth). Rothi *et al.* (1997) provide examples of the first two: they ask patients to 'show me how you would use this' with an object present or ask them to 'show me how you use this tool that I am placing in your hand'. Rothi *et al.* have extended this 'artificial' test of impaired voluntary movement to a real-life setting. Using a paradigm employed by Foundas *et al.* (1995), they suggest videotaping a patient as they prepare and eat a meal in their hospital room. The tray on which the meal is presented also has distractor items: the patient's ability to open containers and use condiments at the appropriate time and in the appropriate way are assessed.

Assessment of apraxia involves all typical impairments in limb, whole body or facial movement, as indexed by Goodglass and Kaplan (1983) and Goodglass *et al.*'s (2001) tests of buccofacial function (e.g. coughing, blowing), intransitive limb movement (e.g. waving goodbye), transitive limb movement (brushing one's teeth), whole body movement (e.g. miming how a boxer stands), serial action (e.g. posting a letter), conventional gestures, and pretend use of objects. Poeck's (1986) tests for ideomotor apraxia involve ten items measuring orofacial apraxia (e.g. sticking out the tongue), twenty items assessing upper limb movement (e.g. combing one's hair) and meaningless gestures (e.g. thumping a fist on the chest); for ideational apraxia, tests include those of serial action (e.g. making a cup of coffee). Other tests of limb apraxia include the Florida Apraxia Screening Test – Revised; this assesses, among other movement, transitive gestures that are mimed to a verbal command.

Practical issues in neuropsychological assessment

Apart from the methodological problems that may beset neuropsychological assessment, there are also practical issues that the neuropsychologist needs to address. These include the choice of test (including appropriate administration for age), culture, patient's formal education, the effects of assessor–patient interaction, patient compliance, malingering, faults in conducting or reporting the assessment, and methods of test administration. The discussion point, for example, examines whether neuropsychological assessment is 'culture-free'.

There are also ethical issues to consider. Although outside the remit of this book, this last topic is an important one. Every published study of neuropsychological interest that has employed patients or healthy individuals (and even animals) should have received permission from the ethics committee of the author's institution. Although neuropsychological assessment is used to determine a patient's intellectual ability in a very practical sense, it is also used to accrue information about the validity of the test itself and of the effects of brain damage on test performance. Scientists are conscious of this fact when writing up their studies, and some authors will personally acknowledge the important contribution and cooperation of the patients themselves, especially if the study reported is a case study. Some include such patients as co-authors.

Discussion point: is neuropsychological assessment culture-free?

It may seem a given that a test administered to one culture may not produce the same results when given to a neuropsychologically equivalent group from a different culture: biases in the content of the test, the approaches needed to complete the test and the relevance of the tested function to the culture being assessed can all influence neuropsychological assessment (Ardila 1995).

Various factors can influence test performance, including language, reading ability, socio-economic status, schooling environment, level and quality of education, and culture. However, it is important to note that there are cross-cultural agreements on the use and performance of many tests, in neuropsychology as in psychology generally. The most widely administered test of intelligence, the WAIS-R/III, produces the same factor structure in American blacks when compared with whites, and Spanish- and English-speaking Americans; in Argentinians when compared with Americans; in Italians compared with Americans; and in Chinese compared with Americans (Faulstich *et al.* 1987; Demsky *et al.* 1998; Insua 1983; Orsini and Laicardi 2000; Lynn and Dai 1993). Similar cross-cultural correspondences have been reported in African-Americans and Caucasians on the WAIS-III (Ryan *et al.* 2000).

This agreement does not mean that differences do not exist. For example, tests have to be modified, not simply for language (i.e. translated) but also in terms of content. The vocabulary, information and comprehension tests are the most often changed, because these do sometimes include very culture-specific references (Insua 1983; James and Dalton 1993; Petrie *et al.* 1986).

Comparisons between cultures on subtests have shown some differences. A study of test performance in a sample of 8–90-year-old US, Canadian, Ecuadorian, Iranian and Israeli participants found that while reaction time was not significantly affected by country and level of education, performance on tests of focused attention, problem solving, strategy shifting and response inhibition differed by country and education level (Levav *et al.* 1998).

Whites outperform blacks on the WAIS-R vocabulary and block designs subtests (e.g. Marcopulos *et al.* 1997), Indians on block design (Ardila and Moreno 2001) and African-Americans on block design (Manly *et al.* 1998). This suggests either a real intellectual difference between these groups or that the test is sensitive to culture. New Zealand Maori, for example, exceeded American standardization score averages on the block design subtest but scored lower on the vocabulary test (Ogden and McFarlane-Nathan 1997), a finding that may be attributable to the Maori culture's rich visual culture. The UK outperforms the USA on the arithmetic and digit span subtests (Crawford *et al.* 1995), a finding that the authors attribute to the way in which Americans speak – the American drawl might extend the articulation time needed to rehearse digits, articulation that is vital to digit span.

These findings treat culture – perhaps, rightly – as a unique variable capable of influencing performance. However, there are factors that might interact with culture to influence test performance. For example, reduced performance in elderly African-Americans was removed when age was taken into account (Manly *et al.* 1998). Performance of black African students with an African first language who were taught in historically advantaged 'white' universities were comparable with English-speaking white students. Both groups were university students, but they differed in IQ.

According to Fillenbaum *et al.* (2001), such differences might be due to the quality of education rather than level of education, although this is a very difficult distinction to operationalize. How exactly do you measure quality of education?

Shuttleworth-Edwards *et al.* (2004) administered the WAIS-III to two South African samples who were between 19 and 30 years of age. One was a group of white students with English as their first language; the other, a group of black students with an African first language. In South Africa, the apartheid regime segregated blacks from whites in many different ways, not least educational context. Blacks were taught under the guidance of the Department of Education and Training, and resources were not abundant. The 'socially advantaged' whites attended schools modelled on the fee-paying British public school system, and superior government schools (called Model C schools). These schooling systems, but not the apartheid, continue to exist in South Africa. Shuttleworth-Edwards *et al.* found that the English-speaking white and black students with an African first language who had received the advantaged education produced intelligence scores comparable with US norms; black students with an African first language with disadvantaged schooling produced lower scores.

Education

Any neuropsychological test needs to be comprehensible, and education can often influence test performance in ways that are not attributable to impaired test function. Literacy, for example, can be extremely important to test performance. Ostrosky-Solis *et al.* (2000) administered the Mini Mental State Examination to 430 neuropsychologically normal Mexican participants, divided into three age groups and four education levels. Normal illiterates gave a performance that indicated severe cognitive impairment; those with 'simply' low levels of education showed moderate impairment. Given that this is a test given to the most demented samples to determine their intellectual integrity, the finding that being illiterate or having a low level of education can produce poor test performance undermines its use a little.

Similar effects of levels of education have been reported by Artiola *et al.* (1998), who compared participants from the US/Mexican borderland with a Hispanic sample on sixteen Spanish-language neuropsychological tests. On most of these, there were few differences. On tests where there were differences, however, these were reduced as levels of education increased.

Choice of test

The decision whether to use a battery of tests or a selection of individual tests is largely governed by time and the assessor's hypothesis-testing strategy. If the assessor has a specific hypothesis that can be tested, then individual tests may be more appropriate than a battery, which measures a wide range of abilities. Choice of test is also important, because it is assumed that the results of test performance reflect the behaviour measured

by the test. However, this may not always be the case, and the assessor may make false inferences. For example, a patient with a motor disorder may perform poorly on a task that requires motor movement although the purpose of the test is to examine a cognitive function unrelated to movement. A specific example of this might be performance on the Benton Visual Retention Test, which tests memory for designs by having the patient draw a pattern from memory. Deficits on this tasks are sometimes described as visual memory deficits or taken as evidence of poor visual memory ‘suggesting the impairment of the right hemisphere [or] the right temporal region’ (Walsh 1991). However, as the test involves drawing, the deficit may not be cognitive but executive, praxic or graphic. If the assessor suggested that this motor-impaired individual had impaired visuospatial ability, he or she would be making a false inference, an erroneous conclusion based on misinterpreted data. A means of obviating this problem might be to utilize a version of the task with no motor component, e.g. the multiple-choice version of the test, which requires patients to select the memorized pattern from a choice of four different ones.

Neuropsychological assessment in children

It is probably inappropriate to think of children, in a neuropsychological sense, as simply small adults. Myriad differences exist between the two that makes extrapolating from adult CNS activity and structure (and adult behaviour) to the child’s a questionable exercise (Anderson *et al.* 2001).

First, an immediate difference lies in the cause of brain injury. In children, the trauma is usually the result of some congenital or perinatal condition; in adults, the causes of brain injury can vary from head injury to stroke to tumour to a plethora of other diseases. Children might be recommended for neuropsychological assessment because their behaviour has been disrupted by acquired CNS disorders, developmental disorders (such as spina bifida and cerebral palsy), disorders such as diabetes and phenylketonuria, and disorders that appear to have a link to CNS dysfunction (e.g. autism). Second, the adult, unlike the child, has a wealth of behavioural, emotional and cognitive experiences that might be affected by brain injury: the child’s accretion of experiences is limited. Third, and related to the second point, is the child’s paucity of skill development (compared with the adult): because the child is still developing, some skills may not have emerged at the time of CNS damage. The structure responsible for function in the fully developed adult may not undertake that function in the developing child, because it may not yet have assumed that role (Holmes-Bernstein 1999). Fourth, as Andersen *et al.* have observed, the damage in the majority of CNS disorders in children is very generalized; that is, there are very few focal lesions (as we would find in adults).

These differences suggest caution in interpreting children’s impairment following CNS injury in adult terms (Fletcher and Taylor 1984). In addition, because a child will not have the attentional, intellectual or emotional faculty of adults, neuropsychological tests have been designed specifically for them. Children tire easily and are easily distracted. Therefore administering lengthy test batteries is not likely to lead to trouble-free cooperation, and shorter, easily comprehensible ones should be put in their place. There are also some tests, such as the Tower of Hanoi described in Chapter 5, that show poor retest performance – one would expect repeated administration of this test to show improved performance (Bishop *et al.* 2001).

Some of the test batteries that have been developed and/or adapted for use in the context of child assessment include the Rivermead Behavioural Memory Test and the Test of Everyday Attention for Children (Manly *et al.* 1999). More general test batteries have represented variants of existing adult batteries: the Halstead–Reitan Neuropsychological Test Battery, suitable for 9–14-year-olds; the Reitan–Indiana Neuropsychological Test Battery, suitable for 5–8-year-olds; the Luria–Nebraska Neuropsychological Test Battery, suitable for 8–12-year-olds; and the Neuropsychological Investigation for Children (Koukman *et al.* 1998), suitable for 3–12-year-olds. All are reasonably time-intensive, and all test basic cognitive abilities.

Most clinical neuropsychologists would agree that test performance must be assessed in tandem with other (apparently peripheral) factors such as family context and school life. These factors may be vitally important. According to Rourke *et al.* (1983, 1986), for example, neuropsychological assessment in children involves measuring not only developmental task performance but also the demands placed on the child in their daily life, such as their education and social interaction with family and friends. The second step involves devising an intervention that meets the daily requirements of the child.

According to Anderson and Pentland (1998), however, the most obvious and universal consequence of brain injury in childhood is an impairment in attention. As the section on attention earlier demonstrated, attention is not a particularly easy concept to define operationally or measure. Some assessors rely on qualitative data such as reports from parents or teachers. Others employ tests devised to measure sustained and selective attention. An example of the former would be a ‘continuous performance’ test in which the aim is to detect a specific target from a range of stimuli (typically, this task is long and monotonous – deliberately so). Examples of the latter might be the letter-cancellation task, in which the child is given a series of letters on a page and has to cross off all Cs and Es, or a task in which the child is required to underline specific symbols in an array of different symbols.

Based on responses to these and other tests, clinicians can devise interventions that may reduce, eliminate, limit or compensate for the reported deficit. The box below illustrates one real-life example in which a child with learning difficulties was referred to a clinical neuropsychologist for assessment, and an intervention tailored to address his difficulties.

Assessing neuropsychological performance in children: the case of Peter

In their compendium of information about child neuropsychological assessment, Andersen *et al.* (2001) outline some of the stages involved in the evaluation of children’s neuropsychological performance. They list eight:

1. taking a background history;
2. observing the child’s behaviour (and requesting reports from parents and teachers);
3. assessing intellectual ability;
4. evaluating specific skills;
5. testing hypotheses;
6. formulating an intervention;
7. providing feedback to the child, parent and teacher;
8. evaluating the success or failure of the intervention.

The stages are illustrated by the assessment of a patient they call Peter, a 13-year-old who was referred to a neuropsychologist because he was depressed and lacked motivation in school. He was frequently reprimanded for tardy submission of schoolwork and was reported to be disruptive in class. At home, his parents described him as short-tempered.

Peter was in general good health but suffered an ear infection (a grommet had been implanted at 2 and 4 years of age). His MRI showed no neuroanatomical abnormality, but he was physically short, and puberty was delayed. He was the second of four children from a stable family environment. His siblings did not present with these problems.

Evaluating the teacher's reports, the clinicians noted that Peter had severe learning difficulties: his primary schooling showed that he had impaired reading acquisition. He reported being unfairly treated by his teachers, a feeling that probably promoted his lack of engagement in class.

On tests of intellectual ability, he performed in the above-average range, but his reading level was below the level expected of his age. His language problems manifested themselves in spelling errors and in having difficulty with unfamiliar words. He was unable to identify a misplaced letter in a word: he knew the word was incorrectly spelled but was unable to correct it. Testing also revealed deficits on more specific tasks: block design, digits backwards (reciting a series of digits backwards), copying the Rey figure, and processing speed. All the tests appeared to involve a visual or spatial deficit and an inability to sequence or manipulate material. His Rey performance, for example, while normal (he copied adequately) was characterized by disorganization: he would complete parts of the figure separately, sometimes starting at the top corner and then moving to the bottom; he did not copy details of specific elements of the figure. The more he practised, however, the better this performance became.

On the basis of this information, the clinician recommended that Peter be given extra time in which to complete his written work, that the presentation of work be verbal where possible (despite his reading impairment, his spatial functions were more generally impaired), that complex tasks be broken down into manageable steps, that he use a spell-checker and that class lectures be taped so that they could be transcribed later. All the recommendations were implemented by the teacher.

Six and twelve months after the intervention, Peter showed a steady improvement in his grades and attitude. There was no evidence of depression at follow-up.

Assessor–patient interaction

In a careful neuropsychological examination, instructions and remarks to the patient are standardized and, in a sense, scripted. This scripting is in place to eliminate the obvious problem of inter-tester variability. One tester may be significantly more positive or negative in his reinforcement than another. This biased interaction might be reflected in the patient's performance. To circumvent this problem, tests are accompanied by administration manuals that include specific scripts with instructions and comments to be made by the tester, which must not be deviated from. Other personal factors such as the social interaction between the patient and tester may also be a problem, and overfamiliarity should be avoided, as should overformality.

Patient compliance

The state of the subject is an important factor to consider before neuropsychological testing commences. Apart from neurological abnormality, deficits on tests may result from inadequate patient cooperation and effort, deliberate exaggeration of disability, disorders of mood, hostility and mistrust (Benton 1994). Depression, for example, is one of the more prominent patient factors that is considered, and a neuropsychologist might be asked to assess the extent of mood disorder on performance. The level of depression, whether diagnosed clinically or on the basis of inventory, is high in brain-injured patients (Starkstein and Robinson 1991), especially those with stroke (Aben *et al.* 2002). This symptom interacts with personality, so that those scoring high on the personality trait of neuroticism were four and a half times more likely to develop depression post-stroke than were low scorers, an interaction that is more strongly seen in men.

Malingering

A patient with strong negative motivation (not wanting to do well) is, legally, a serious problem, since dissembling on tests may support a defence of mental incompetence or a claim for industrial compensation in court proceedings (Larrabee 1990). A careful consideration of the patient's history and character is therefore important. One method of combating this simulation or exaggeration on tests is to administer tests that are so easy that even the brain-damaged may succeed at them (Rey 1941, 1964). A second approach is to note whether the patient's performance conforms to expectations based on his brain injury. If performance is below expectation, simulation may be inferred (Benton and Spreen 1961). The relative success and failure of these malingering tests is considered in the discussion point at the end of the chapter.

Faults in conducting and reporting the results of neuropsychological assessment

During the course of neuropsychological assessment, there may be faults in the conduct of the examination. These may include a failure to consider events close to the time of the injury or a failure to assess the rate and degree of improvement over time. Deficits that are not apparent until some time after the event may not be neurological in origin (Walsh 1991). Also, it may be appropriate to consider behaviour outside the prescriptive context of the testing situation. Walsh (*ibid.*) describes this as 'coffee-break testing'. This refers to the non-deliberate assessment of the patient during a break in testing when the patient is seen to relax and perform quite differently from when observed in a formal setting. For example, patients performing poorly on certain aspects of aphasia tests may show no difficulty with the same linguistic constructions during the break but repeat the failures when the testing recommences. Patients may also indicate difficulty in understanding test instructions but understand equally complex syntactic structures in normal conversation. It is therefore important to bear in mind the formal nature of the testing and the possible intellectual intimidation that may arise. This also highlights the importance of having test

instructions that are unambiguous: instructions should be comprehensible to patients of high, intermediate and low intellectual ability.

Faults in reporting the examination are sometimes found in medico-legal reports of neuropsychological cases. Problems may involve the inadequate reporting of facts from which deductions are made, such as using terms like 'average score' and 'superior'. Instead, the neuropsychologist should present 'hard' quantitative data, not simply impressions or overgeneralizations. Reports might often compare an individual's performance against the 'norm', a procedure that, as we have seen above, is problematic. The report might also not consider possible reasons for failure on a test. The sin of summation could also be committed, where scores from a number of tests are summed to produce one general score. If a test has easy and difficult items, an average such as this will not indicate whether the individual had specific difficulty on the easy, moderately easy or hard items. Alternatively, individuals may have performed badly on early items but performed well at more advanced levels. This sometimes happens.

Computer-based assessment

In recent years, attempts have been made to eliminate the problem of tester influence by developing methods of computer-based assessment. A computerized method of administration has many advantages: it presents all information in a standardized and consistent manner; a computer does not get bored, angry or tired; inadvertent prompting is avoided; responses may be accurately recorded; complex analysis and scoring may be undertaken quickly; results may be made available almost immediately after testing; and data may be saved directly onto a disk drive (Wilson and McMillan 1991). Up to 60 percent of testing time can be saved (French and Beaumont 1987).

One series of neuropsychological tests is the Cambridge Neuropsychological Test Automated Battery (CANTAB), developed by Trevor Robbins and his colleagues at Cambridge University. This series, a collection of different batteries, evaluates visual memory, attention, working memory and planning via computerized tests and has been used to evaluate deterioration in Alzheimer's disease, Parkinson's disease, depression, multiple sclerosis, schizophrenia, autism and the dementia that accompanies AIDS (Morris *et al.* 1986; Sahakian and Owen 1992; Robbins and Sahakian 1994). A brief list of commonly used computerized tests can be found in Table 14.3.

French and Beaumont (1987) reported that of eight tests administered to psychiatric patients, none was reported to be more enjoyable in its standard, non-computerized form. There are also reports of successful use with elderly patients (Carr *et al.* 1982; Morris *et al.* 1988). More pertinently, various keyboard manipulations are available for physically disabled people.

There are limitations to this method of test administration, however. For example, the type of material that computer packages can present is limited. Questionnaires with easy scoring systems, such as yes/no or multiple-choice questions, are relatively easy to present and score on computer. Questionnaires with open answers, such as comprehension questions, are more difficult to score. As a result, current computer-based tests tend to be in multiple-choice format. Finally, whereas a battery such as the WAIS-R may be taken outside the hospital setting and is easy to carry around, moving a large computer is a problem. A more obvious disadvantage is that a computer might not be able to gain information about a person's behaviour, such as the patient's mood and comportment, outside test administration.

Table 14 3 Some computerized tests used in neuropsychological assessment**Computerized test batteries**

Automated Cognitive Test System (Stollery 1988)
 Assessment of Cognitive Skills Battery (Powell *et al.* 1990)
 Automated Neuropsychological Assessment Metrics (Reeves and Kane 1992)
 Automated Portable Test System – from PETER, see below (Bittner *et al.* 1986)
 Automated Performance Test System (Kennedy *et al.* 1985)
 Cambridge Neuropsychological Test Automated Batteries (Frey and Robbins 1986)
 CANTABeclipse (two new tests)
 Complex Cognitive Assessment Battery (Samet *et al.* 1986)
 COGSCREEN (Engleberg *et al.* 1986)
 Memory Assessment Clinics Battery (Larabee and Crook 1988)
 Microcog – The Assessment of Cognitive Functioning (Powell *et al.* 1993)
 NES2 – Neurobehavioural Evaluation System 2 (Baker and Letz 1985)
 PETER – Performance Evaluation Tests of Environmental Research

Stand-alone

Non-verbal Selective Reminding Test (Kane and Perrine 1988)
 Verbal Selective Reminding Test (Kane and Perrine 1988)
 Serial Recall Assessment (1987)
 Sunrise Systems Continuous Performance Test
 Test of Variables of Attention (McCarney and Greenberg 1990)

Source: adapted from Armstrong 2004.

Discussion point: how to identify a patient malingering on a neuropsychological test

From a legal, scientific and clinical point of view, it is important that a patient sitting a test gives answers that reflect the best of his or her current ability. Clinically, low scores indicate some profound underlying abnormality. Legally, significantly low scores have implications for the patient's financial well-being. The ability to receive financial compensation from an employer may depend on the demonstration of significantly impaired functioning following an industrial accident or exposure to hazardous materials, for example. For this reason, assessors are conscious of deliberate low scoring on neuropsychological tests.

A small number of test approaches thought to detect extremely abnormal low scores has been developed. One simple sign of malingering is poor performance entirely out of keeping with the extent of the patient's brain damage, i.e. only the most severely brain damaged would fail the test. Another is to determine cut-off points. For example, one study examined the performance of identified malingerers and non-malingerers using a collection of tests, including the Halstead-Reitan and WAIS-R (Trueblood and Schmidt 1993). They identified seven 'invalidity indicators' on which cut-off points could identify malingerers. Cut-off points for two or more of these indicators were able to identify most of the suspected malingerers.

An early method of identifying malingerers was the administration of an extended intellectual ability test. Malingerers would often exaggerate their deficits, performing

even more poorly than *bona fide* patients. However, malingerers have been able to mimic successfully levels of intellectual impairment seen in genuinely brain-damaged individuals. What appears to be important is the pattern of performance on tests (Tenhula and Sweet 1996). For example, digit span test performance tends to be lower relative to scores on other tests on the WAIS-R for malingerers (Mittenberg *et al.* 1995). Similarly, low scores on aspects of some tests (e.g. Weschler Memory Scales, WMS) can distinguish the genuine from the disingenuous patient. Performance on the figural memory scale of the WMS is poorer in malingerers than in brain-damaged patients (Bernard 1990).

Wiggins and Brandt (1988) have suggested that whereas the genuinely brain-damaged have relatively intact recognition memory but impaired recall, the malingerers may show the opposite pattern (see below). The tests that typically distinguish malingerers from non-malingerers are tests on which brain-damaged individuals should not show remarkable deficits, because they are relatively simple tests. From studies such as these, extremely simple tests have been constructed to identify malingerers, e.g. symptom validity testing. These tests may take the form of forced recognition exercises, whereby a string of digits might be presented to the subject. After the string disappears and a delay of thirty seconds has occurred, the subject is presented with two other strings and is asked to decide which of the two was the one previously presented. The results are not completely malingering-proof, although it has been suggested that the malingeringer might find it difficult to score within chance levels with repeated testing (Lezak 1995).

One test that may distinguish the malingeringer from the non-malingeringer is the Halstead-Reitan Category Test (CT). This examines the patient's ability to engage in abstract reasoning and contains easy and difficult questions in the form of multiple-choice alternatives. If, as is suspected, malingerers exaggerate performance regardless of the actual difficulty of the test, their performance should identify them. Eighteen of the items on this test are almost never failed by genuine patients. If a patient gets two or more of these wrong, he or she ought to be treated with suspicion. However, even this criterion is questionable. One study has shown no significant difference between malingerers and non-malingerers (Trueblood and Schmidt 1993), while another has actually found poorer performance on the CT in patients with genuine damage.

Tenhula and Sweet (1996) attempted to standardize a test of malingering based on the validity of the CT, using brain-damaged individuals, normal controls and individuals asked to simulate brain injury. Optimal cut-off points correctly classified each group in 64.1–91.5 percent of cases. The best index of discrimination was performance on subtests I and II, which correctly identified 92.2 percent of subjects with no false positives. The authors argue that the test should not be administered in isolation if the detection of malingering is the aim.

Perhaps the problem of identifying malingerers is most prominent in cases of amnesia (Brandt 1992; Leng and Parkin 1995). Suspected malingerers will not admit their deceit even when their deficits are so gross that they are utterly incompatible with the true amnesic syndrome. One approach to sorting out the truly amnesic from the feigned is to obtain scores on tests from individuals who are instructed to simulate amnesia, i.e. they perform as they imagine an amnesiac would. The assumption behind this approach is that simulators and malingerers have similar ideas about the effects of memory impairment. These views may contradict actual findings from the amnesiacs themselves. In one such experiment, a group of normal controls, amnesiacs and simu-

lators were required to answer a set of fourteen autobiographical questions in a structured interview (Wiggins and Brandt 1988). Although all controls and amnesiacs could give their name, date of birth, home address, mother's maiden name and father's first name, a substantial percentage of simulators failed to answer these questions. Twenty-four hours after the initial interview, simulators were better than real amnesiacs at answering the questions 'what is my [the experimenter's] name?' and 'what did you have for dinner last night?' Although the interview does discriminate between the feigned and real amnesiacs on a number of items, the percentage actually feigning for each item is not large. The highest percentage of incorrect or false answers given by simulators was 48 percent. This was in response to the question 'what is your social security number?' – 4 percent of controls and 38 percent of amnesic patients were unable to answer this question.

When participants are deliberately asked to simulate malingering and are informed that this malingering would be monitored, the magnitude of the participants' errors have been found to distinguish them from healthy controls and brain-injured patients (Bender and Rogers 2004). Error magnitude refers to simulators' lack of concern over which items they complete correctly and which not. This index has also been a useful way of identifying malingerers on the WMS-R (Martin *et al.* 1998). If psychology and neuroscience students are coached in how post-concussive patients behave and asked to malingering on the Rey-O and the dot-counting test, they show less evidence of malingering on the memory component of the tasks but not the timed ones compared with those who were not instructed. Those who were told that compensation would follow if performance was impaired were the worst (i.e. most flagrant) malingerers (Erdal 2004). Suhr and Gunstad (2000) also found that warning coached participants that their malingering would be examined led to a reduction in poor performance. However, sometimes a lot rather than a little information can be counter-productive. Physicians asked to malingering the consequences of head injury performed more poorly on the WMS than did lawyers (Schwartz *et al.* 1998). Similarly, nurses performed more poorly than patients when asked to malingering on neuropsychological tests (Hayward *et al.* 1987). Even the genuinely head-injured are poorer at feigning neuropsychological test performance than are controls (Vickery *et al.* 2004).

There is probably no test that is guaranteed to detect exaggerated, deliberate and misleading poor intellectual performance. However, all the approaches reviewed above have some practical validity, especially when employed collectively.

Summary

Neuropsychological assessment refers to the testing of a neurological patient's motor, cognitive and emotional function. Assessment has several aims, perhaps the most important of them being (1) the identification of the presence of cognitive impairment, (2) the differentiation between brain injury and other factors as causes of cognitive impairment, and (3) the facilitation of the patient's rehabilitation or recovery of function. The neurological examination aims to establish deficits in lower- and higher-order CNS function and to localize these deficits. This is normally conducted by a neurologist. Neuropsychological assessment may utilize a standardized collection of tests measuring various intellectual functions, called a fixed battery, or a flexible selection of tests. The choice is largely

governed by time, the examiner's hypothesis-testing strategy and the availability of the test. The most commonly used intellectual test battery is the Wechsler Adult Intelligence Scale – Revised (WAIS-R)/Wechsler Adult Intelligence Scale – III (WAIS-III). This comprises two scales: verbal IQ and performance IQ. The two other major test batteries are the Halstead–Reitan Neuropsychological Battery and the Luria–Nebraska Neuropsychological Battery, although these are not as widely used now as once they were. The Luria–Nebraska, in particular, has problems of methodology and standardization. Tests of individual function can be used to measure general cognitive ability, premorbid intelligence, reasoning and concept formation, memory, attention and vigilance, language ability, and visuospatial function. Premorbid measure of intelligence refers to some estimate of how intellectually capable the patient was before their brain injury. For example, this is important in trying to assess the person's general intelligence when the brain injury produces impairments on various other cognitive tests. One of the more widely used and validated tests of premorbid intellectual function is the National Adult Reading Test. Practical issues to consider in the administration of neuropsychological tests include (1) whether to administer fixed batteries or individual tests, (2) avoiding false inferences, (3) ensuring clarity and lack of ambiguity in test instructions, (4) taking into account the patient's behaviour in an informal context as well as in the formal testing context ('coffee-break testing'), (5) noting the mood, behaviour and cooperativeness of the patient, (6) ensuring clarity in the description of the quantitative results of the assessment, and (7) the application of computer-based neuropsychological assessment tests.

Recommended further reading

- Ferraro, F.R. (2001). *Minority and Cross-cultural Aspects of Neuropsychological Assessment*. Hove, UK: Psychology Press.
- Halligan, P.W., Kischka, U. and Marshall, J.C. (2003). *Handbook of Clinical Neuropsychology*. Oxford: Oxford University Press.
- Krull, K.R. and Adams, R.L. (1997). Problems in neuropsychological research methodology. In M.E. Maruich and J.A. Moses (eds), *Clinical Neuropsychology: Theoretical Foundations for Practitioners*. New Jersey: Lawrence Erlbaum.
- Larrabee, G.J. (2004). A review of the clinical interpretation of the WAIS-III and WMS-III: where do we go from here and what should we do with WAIS-IV and WMS-IV? *Journal of Clinical and Experimental Neuropsychology*, 26, 5, 706–17.
- Lezak, M.D., Howieson, D.B. and Loring, D.W. (2004). *Neuropsychological Assessment*, fourth edition. New York: Oxford University Press.
- Maarse, F.J., Mulder, L.J.M., Brand, A.N. and Akkerman, A.E. (2003). *Clinical Assessment, Computerised Methods and Instrumentation*. Hove, UK: Psychology Press.
- Ricker, J.H. (2003). *Differential Diagnosis in Adult Neuropsychological Disorders*. New York: Springer Verlag.
- Rourke, B.P., van der Vlugt, H. and Rourke, S.B. (2002). *Practice of Child-clinical Neuropsychology*. Hove, UK: Psychology Press.
- Sparrow, S.S. and Davis, S.M. (2000). Recent advances in the assessment of intelligence and cognition. *Journal of Child Psychology and Psychiatry*, 41, 1, 117–31.
- Whitworth, A., Webster, J. and Howard, D. (2005). *A Cognitive Neuropsychological Approach to Assessment and Intervention in Aphasia*. Hove, UK: Psychology Press.
- Wycherley, R., Lavender, A., Holtum, S., Crawford, J.R. and Mockler, D. (2005). WAIS III UK: An extension of the UK comparability study. *British Journal of Clinical Psychology*, 44, 279–88.

Appendix: resources for neuropsychology students

Sources of information

Journals

Neuropsychology websites and software

Societies

Sources of information

A number of important resources are available to students of neuropsychology to help you get to grips with the subject. The best and obvious source is reading material, particularly refereed journals that carry interesting empirical research or literature reviews in human neuropsychology. Another source of information is the World Wide Web and computer software. The former is the most advanced resource available to any student. While a lot of what you find on the Internet is quirky or, frankly, rubbish, there are sites that you can visit that offer excellent written and visual resources to any student interested in neuropsychology.

This chapter is designed to provide you with a non-exhaustive list of the types of resource available in human neuropsychology that can help you, as a student, to gain a better understanding of the subject.

Journals

Visit any journal section in any university library and it will seem as if there is a journal covering almost every academic topic imaginable. Publishers have become keen to publish new and more specialized journals, which has resulted in an increase in the number of potential outlets for publishing results and disseminating information. General journals continue to flourish and for good reason: these tend to be the journals that most researchers would like to publish their findings in. Examples include *Nature*, *Neuroscience* and *Science*. General neuropsychology journals include *Brain*, *Journal of Neuroscience* and *Neuropsychologia*. *Neuropsychologia*, for example, includes papers on topics ranging from olfactory lateralization in chicks to frontal lobe dysfunction and impaired face recognition. Journals such as *Laterality* and *Visual Neuroscience*, on the other hand, limit their coverage to those two aspects of neuropsychology. Often, these specialized journals become leaders in their field.

Below is a list of the more prominent or relevant journals in human neuropsychology. Not every library is going to stock all of them (there are over 100), but any good library should physically stock a selection or have online access to them. You should consult the latest issues of these journals regularly: they allow you to keep up to date with fresh findings in the area.

Acta Neuropsychiatrica
Aging, Neuropsychology and Cognition
Alzheimer's Disease and Associated Disorders
American Journal of Psychiatry
Annals of Neurology
Annual Review of Neuroscience
Annual Review of Psychology
Aphasiology
Applied Neuropsychology
Archives of Clinical Neuropsychology
Archives of General Psychiatry
Archives of Neurology
Behavioural Brain Research
The Behavioural and Brain Sciences
Behavioural Neurology
Behavioural Neuroscience
Biological Psychiatry
Biological Psychology
Brain
Brain and Cognition
Brain and Development
Brain and Language
Brain, Behaviour and Immunity
Brain Injury
Brain Pathology
Brain Research
Brain Research Bulletin
Brain Research Reviews
British Journal of Clinical Psychology
British Journal of Psychiatry
Canadian Journal of Neurological Science
Cerebral Cortex
Child Neuropsychology
The Clinical Neuropsychologist
Cognition and Emotion
Cognitive Brain Research
Cognitive Neuropsychiatry

Cognitive Neuropsychology
Cognitive Science
Cortex
Current Opinion in Neurobiology
Developmental Brain Research
Developmental Medicine and Child Neurology
Developmental Neuropsychology
Developmental Psychobiology
Dyslexia
Electroencephalography and Clinical Neurophysiology
Epilepsy and Behaviour
European Journal of Neuroscience
Experimental Brain Research
Experimental Neurology
Human Brain Mapping
International Journal of Clinical Neuropsychology
International Journal of Developmental Neuroscience
International Journal of Neuroscience
International Journal of Psychophysiology
Italian Journal of Neurological Sciences
Journal of Cerebral Blood Flow and Metabolism
Journal of Clinical and Experimental Neuropsychology
Journal of Cognitive Neuroscience
Journal of Cognitive Rehabilitation
Journal of Forensic Psychology
Journal of Head Trauma Rehabilitation
Journal of Nervous and Mental Disorders
Journal of Neurobiology
Journal of Neurology, Neurosurgery and Psychiatry
Journal of Neuroimaging
Journal of Neurophysiology
Journal of Neuropsychiatry
Journal of Neuropsychology
Journal of Neuroscience
Journal of Psychophysiology
Journal of Speech and Hearing Research
Journal of the History of the Neurosciences
Journal of the International Neuropsychological Society
Journal of the Neurological Sciences
Laterality

Movement Disorders
Nature Neuroscience
Neurobiology of Ageing
Neurobiology of Learning and Memory
Neurocase
Neuroimage
Neurology
Neuron
Neuropsychobiology
Neuropsychologia
Neuropsychological Rehabilitation
Neuropsychology
Neuropsychology, Development and Cognition
Neuropsychology Review
Neuropsychopharmacology
Neurorehabilitation
NeuroReport
Neuroscience
Neuroscience and Behavioural Physiology
Neuroscience and Biobehavioural Reviews
Neuroscience Letters
The Neuroscientist
Parkinsonism and Related Disorders
Physiology and Behaviour
Proceedings of the National Academy of Sciences
Progress in Brain Research
Progress in Neurobiology
Psychiatric Research Neuroimaging
Psychobiology
Psychological Science
Psychophysiology
Reading and Writing
Science
Trends in Cognitive Sciences
Trends in Neurosciences
Vision Research
Visual Neuroscience

There are links to electronic forms of some of these journals here:

<http://journalseek.net/psyc.htm>

<http://www.fil.ion.ucl.ac.uk/resources/journals.html>

<http://www.tandf.co.uk/journals/listings/psych.asp>

Neuropsychology websites and software

The websites listed below are those that provide excellent written and visual material for any person interested in neuropsychology. These sites provide information about neuropsychological subjects, addresses of important societies and research groups, links to neuropsychology journals and books, news about forthcoming conferences, and much else besides. Because the Internet is of the moment, continually evolving and regularly updated, some sites become out-of-date or obsolete very quickly. Sites are normally constructed and maintained by one person, whom you should be able to contact with suggestions or queries via his or her email address on the page.

The sites below have been highlighted based on the prediction that they will still be in operation by the time that you read this. An important feature of these sites is that they provide you with links to other web pages of interest. In this sense, the Internet is a bit like opening one door to reveal a series of doors. Enter one of these, and another series of doors awaits you. It is not difficult to understand why some individuals become addicted to the Internet.

Neuropsychology Central

Address: www.neuropsychologycentral.com

Content: A good neuropsychology site. It has information about major strands of neuropsychology – including primers on topics such as assessment of language – as well as links to organizations, newsgroups, jobs and assessment procedures.

World Wide Web Virtual Library for Neuroscience

Address: neuro.med.cornell.edu/VL/

Content: A collection of neuroscience references.

Cognitive Neuroscience Resources

Address: www.cs.cmu.edu/Web/Groups/CNBC

Content: A list of links providing resources for the cognitive neuroscientist.

Neuroscience on the Internet

Address: www.lm.com/~nab/

Content: A list of links of interest to neuroscientists.

Neurosciences on the Net

Address: www.lm.com/~nab/neuroimg.html/non.html

Content: A wide range of links to neuropsychology-related sites.

Neuroscience Search Engine

Address: www.acsiom.org/nsr/neuro.html

Content: This is a search engine that will allow you to find websites relevant to your keyword search.

Yahoo Neuroscience

Address: www.yahoo.com/Health/Medicine/Neuroscience

Content: Yahoo is one of the Internet's premier search engines – this is the result of its best website matches for neuroscience.

Brain Collection Resources

Address: www.neurophys.wisc.edu/brain/othercollec.html

Content: Large number of sites with brain atlases, including the two described immediately below.

Wisconsin/Michigan State Brain Collection

Address: www.neurophys.wisc.edu/brain/

Content: A collection of images of mammalian brain sections.

The Whole Brain Atlas

Address: www.med.harvard.edu/AANHB/home.html

Content: An impressive collection of human brain sections and MRI/PET images, normal and abnormal.

Human Neuroanatomy and Neuropathology

Address: www.lm.com/~nab/neuroimg_1.html/human_neuroanatomy

Content: A collection of images from human neuroanatomy, normal and abnormal.

The Harvard Brain

Address: hcs.harvard.edu/~husn/BRAIN/index.html

Content: An impressive Internet magazine on the brain, designed and written by Harvard neuroscience undergraduates.

Encyclopaedia of Psychology: Neuroscience

Address: www.psychology.org/links/Paradigms_and_Theories/Neuroscience/

Content: An excellent collection of links to neuroscience sites.

Brain Model Tutorial by Mark Darty

Address: pegasus.cc.ucf.edu/~Brainmdl/brain.html

Content: An Internet tutorial on parts of the brain and what they do.

Online documents: Psychophysiology and biological psychology

Address: www.psychologie.uni-bonn.de/online-documents/lit_pp.htm

Content: Allows you access to full-text versions of articles on psychophysiology.

Drugs, brains and behaviour, by Robin Timmons and Leonard Hamilton

Address: www.rci.rutgers.edu/~lwh/drugs/

Content: A link to an online book.

PsychNet-UK

Address: www.psychnet-uk.com/neuropsychology/neuropsychology.htm

Content: A large collection of sites of a neuropsychological nature.

Neuropsychological PhD dissertations

Address: www.open-rehab.com/dissert.htm

Content: A collection of PhD theses with a neuropsychological flavour.

Rehabtool.com

Address: www.rehabtool.com/links.html

Content: A collection of links to software available for cognitive rehabilitation.

Computer Programs for Research and Practice in Neuropsychology

Address: www.abdn.ac.uk/~psy086/dept/psychom.htm

Content: A collection of free software designed by Professor John Crawford for neuropsychological assessment.

Careers advice for potential neuropsychologists

Address: www.bps.org.uk/careers/areas/neuropsychology.cfm

The author

Address: www.mdx.ac.uk/www/psychology/staff/nmartin.html

Content: The author's page can currently be found at this link.

Societies

A small number of learned and scientific societies exists to promote and discuss neuropsychology. Two divisions of the American Psychological Association, for example, are devoted to behavioural neuroscience. There is an international society as well as several smaller national societies. There are also other societies devoted to particular aspects of neuropsychology, such as language or Alzheimer's disease, and these are many. The societies listed below are general societies. Many of these have strict membership application rules, so that undergraduates may join only on graduation or applicants must have a PhD or work/research in human neuropsychology. These may still be useful, because you may be able to get onto their mailing list (for a small fee). In return, you will receive news of the society, its members and any forthcoming conferences. However, other societies do not impose such membership restrictions.

Below is a short list of societies that you might contact for further information, especially if you decide to become involved in human neuropsychology in a research or clinical capacity.

American Psychological Association, Divisions 6 and 40

Address: www.div40.org/

British Psychological Society, Division of Neuropsychology

Address: www.mrc-cbu.cam.ac.uk/Common/rehab/Tom.Manly/DON.htm

British Neuropsychological Society

Address: www.psychology.nottingham.ac.uk/bns/

Membership is open to anyone who 'can demonstrate a commitment to neuropsychology', which limits it to graduates and professionals.

International Neuropsychological Society

email: osu_ins@postboc.acs.ohio-state.edu

This has over 3300 members, and a subscription will also bring you the society's journal, *Journal of the International Neuropsychological Society*.

National Academy of Neuropsychology

Address: www.nanonline.org/

Subscription comes with the *Archives of Clinical Neuropsychology*.

Society for Psychophysiological Research

Address: sprweb.org/~spr/

This is the largest society for psychophysiological research and offers student membership. A subscription to the journal *Psychophysiology* is included in the membership fee.

Society for Neuroscience

Address: web.sfn.org/

References

- Aarts, J.H.P., Binnie, C.D., Smith, A.M. and Wilkins, A.J. (1984). Selective cognitive impairment during focal and generalized epileptiform EEG activity. *Brain*, 107, 293–308.
- Abel, T. and Lattal, K.M. (2001). Molecular mechanisms of memory acquisition, consolidation and retrieval. *Current Opinion in Neurobiology*, 11, 180–7.
- Aben, I., Denollet, J., Lousberg, R., Verhey, F., Wojciechowski, F. and Honig, A. (2002). Personality and vulnerability to depression in stroke patients. *Stroke*, 33, 2391–5.
- Aboitiz, F., Scheibel, A.B., Fisher, R.S. and Zaidel, E. (1992). Fiber composition of the human corpus callosum. *Brain Research*, 598, 143–53.
- Ackerman, P.L., Beier, M.E. and Boyle, M.O. (2005). Working memory and intelligence: the same or different constructs? *Psychological Bulletin*, 131, 1, 30–60.
- Adams, R.D. and Victor, M. (1993). *Principles of Neurology* (5th edition). New York: McGraw-Hill.
- Adolphs, R., Russell, J.A. and Tranel, D. (1999). A role for the human amygdala in recognizing emotional arousal from unpleasant stimuli. *Psychological Science*, 10, 167–71.
- Adolphs, R., Damasio, H., Tranel, D. and Damasio, A.R. (1996). Cortical systems for the recognition of emotion in facial expressions. *Journal of Neuroscience*, 16, 23, 7678–87.
- Adolphs, R., Tranel, D. and Buchanan, T.W. (2005). Amygdala damage impairs emotional memory for gist but not details of complex stimuli. *Nature Neuroscience*, 8, 4, 512–18.
- Adolphs, R., Tranel, D., Damasio, H. and Damasio, A. (1994). Impaired recognition of emotion in facial expressions following bilateral damage to the human amygdala. *Nature*, 372, 669–72.
- Adolphs, R., Tranel, D., Damasio, H. and Damasio, A. (1995). Fear and the human amygdala. *Journal of Neuroscience*, 15, 9, 5879–91.
- Adrian, E.D. and Mathews, B.H.C. (1934). Berger rhythm: potential changes from the occipital lobes of man. *Brain*, 57, 355–85.
- Aggleton, J.P. (1992). *The Amygdala: Neurobiological Aspects of Emotion, Memory and Mental Dysfunction*. New York: Wiley/Liss.
- Aggleton, J.P., Bland, J.M., Kentrige, R.W. and Neave, N.J. (1994). Handedness and longevity: archival study of cricketers. *British Medical Journal*, 309, 1681–4.
- Aggleton, J.P., Kentrige, R.W. and Neave, N.J. (1993). Evidence for longevity differences between left-handed and right-handed men: an archival study of cricketers. *Journal of Epidemiology and Community Health*, 47, 3, 206–9.
- Aggleton, J.P. and Mishkin, M. (1986). The amygdala: sensory gateway to the emotions. In R. Plutchik and H. Kellerman (eds), *Biological Foundations of Emotion*, Volume 3. New York: Academic Press.
- Aggleton, J.P. and Shaw, C. (1996). Amnesia and recognition memory: a re-analysis of psychometric data. *Neuropsychologia*, 34, 51–62.
- Aguirre, G.K., Zarahn, E. and D'Esposito, M. (1998). An area within human ventral cortex sensitive to 'building' stimuli: evidence and implications. *Neuron*, 21, 373–83.
- Akelaitis, A.J. (1944/45). Studies on the corpus callosum IV: diagnostic dyspraxia in epileptics following partial and complete section of the corpus callosum. *American Journal of Psychiatry*, 101, 594–9.
- Alajouanine, T. and Lhermitte, F. (1965). Acquired aphasia in children. *Brain*, 88, 653–62.
- Albert, M. and Bear, D. (1974). Time to understand: a case study of word deafness with reference to the role of time in auditory comprehension. *Brain*, 97, 373–84.
- Albert, M. and Moss, M. (1983). The assessment of memory disorders in patients with Alzheimer's disease. In N. Butters and L.R. Squire (eds), *Neuropsychology of Memory*. New York: Guilford Press.
- Alderman, N., Burgess, P.W., Knight, C. and Henman, C. (2003). Ecological validity of a simplified version of the multiple errands test. *Journal of the International Neuropsychological Society*, 9, 31–44.
- Alexander, G.E., Crutcher, M.D. and DeLong, M.R. (1990). Basal ganglia – thalamocortical circuits: parallel substrates for motor, oculomotor, 'prefrontal' and 'limbic' functions. *Progress in Brain Research*, 85, 119–46.
- Alexander, M.P. and Albert, M.L. (1983). The anatomical basis of visual agnosia. In A. Kertesz (ed.), *Localization in Neuropsychology*. New York: Academic Press.
- Alford, L.B. (1933). Localization of consciousness and emotion. *American Journal of Psychiatry*, 12, 789–99.

- Allen, G. (1878). Note-deafness. *Mind*, 10, 157–67.
- Almkvist, O., Backman, L., Basun, H. and Wahlund, L.-O. (1993). Patterns of neuropsychological performance in Alzheimer's disease and vascular dementia. *Cortex*, 29, 661–73.
- Alonso, P., Pujol, J., Cardoner, N., Benlloch, L., Deus, J., Menchon, J.M., Capdevila, A. and Vallejo, J. (2001). Right prefrontal repetitive transcranial magnetic stimulation in obsessive-compulsive disorder: a double-blind, placebo-controlled study. *American Journal of Psychiatry*, 158, 1143–5.
- Alvarez, P. and Squire, L.R. (1994). Memory consolidation and the medial temporal lobe: a simple network model. *Proceedings of the National Academy of Sciences*, 91, 7041–5.
- Amaral, D.G. (2002). The primate amygdala and the neurobiology of social behaviour: implications for understanding social anxiety. *Biological Psychiatry*, 51, 11–17.
- American Psychiatric Association (1994). *Diagnostic and Statistical Manual of Mental Disorders* (fourth edition). Washington: American Psychiatric Association.
- Amieva, H., Jacqmin-Gadda, H., Orgogozo, J.-M., Le Carret, N., Helmer, C., Letenneur, L., Barberger-Gateau, P., Fabrigoule, C. and Dartigues, J.-F. (2005). The 9 year cognitive decline before dementia of the Alzheimer type: a prospective population-based study. *Brain*, 128, 1093–101.
- Andersen-Ranberg, K. *et al.* (2001). Dementia is not inevitable: a population-based study of Danish centenarians. *Journal of Gerontology*, 56, 152–9.
- Anderson, A.K., Christoff, K., Stoppen, I., Panitz, D., Ghahremani, D.G., Glover, G., Gabrieli, J.D. and Sobel, N. (2003). Dissociated neural representations of intensity and valence in human olfaction. *Nature Neuroscience*, 6, 196–202.
- Anderson, M.G. (1989). Lateral preference and longevity. *Nature*, 341, 112.
- Anderson, S.W., Damasio, H., Jones, R.D. and Tranel, D. (1991). Wisconsin Card Sorting Test performance as a measure of frontal lobe damage. *Journal of Clinical and Experimental Neuropsychology*, 13, 909–22.
- Anderson, V., Catroppa, C., Morse, S., Haritou, F. and Rosenfeld, J. (2000). Recovery of intellectual ability following TBI in childhood: impact of injury severity and age at injury. *Pediatric Neurosurgery*, 32, 282–90.
- Anderson, V. and Moore, C. (1995). Age at injury as a predictor of outcome following pediatric head injury. *Child Neuropsychology*, 1, 187–202.
- Anderson, V., Northam, E., Hendy, J. and Wrennall, J. (2001). *Developmental Neuropsychology: A Clinical Approach*. Hove, UK: Psychology Press.
- Anderson, V. and Pentland, L. (1998). Residual attention deficits following childhood head injury. *Neuropsychological Rehabilitation*, 8, 283–300.
- Anderton, B.H. (1987). Alzheimer's disease: progress in molecular pathology. *Nature*, 325, 648–9.
- Andreasen, N.C., O'Leary, D.S., Flaum, M., Nopoulos, P., Watkins, G.L. and Ponto, L.L.B. (1997). Hypofrontality in schizophrenia: distributed dysfunctional circuits in neuroleptically naive patients. *The Lancet*, 349, 1730–4.
- Annegers, J.F., Grabow, J.D., Groover, R.V., Laws, E.R., Elveback, L.R. and Kurland, L.T. (1980). Seizures after head trauma: a population study. *Neurology*, 30, 683–9.
- Annett, M. (1970). A classification of hand preference by association analysis. *British Journal of Psychology*, 63, 343–58.
- Annett, M. (1985). *Left, Right, Hand and Brain: The Right Shift Theory*. Hove, UK: Lawrence Erlbaum.
- Annett, M. (1992). Spatial ability in subgroups of left and right handers. *British Journal of Psychology*, 83, 493–515.
- Annett, M. (1993). Handedness and educational success: the hypothesis of a genetic balanced polymorphism with heterozygote advantage for laterality and ability. *British Journal of Developmental Psychology*, 11, 359–70.
- Annett, M. and Manning, M. (1990). Reading and a balanced polymorphism for laterality and ability. *Journal of Child Psychology and Psychiatry*, 31, 4, 511–29.
- Ansaldi, A.I., Arguin, M. and Lecours, A.R. (2002a). Initial right take-over and subsequent bilateral participation during recovery from aphasia. *Aphasiology*, 16, 3, 287–304.
- Ansaldi, A.I., Arguin, M. and Lecours, A.R. (2002b). The contribution of the right cerebral hemisphere to the recovery from aphasia: a single longitudinal case study. *Brain and Language*, 82, 206–22.
- Ansaldi, A.I., Arguin, M. and Lecours, A.R. (2004). Recovery from aphasia: a longitudinal study on language recovery, lateralization patterns and attentional resources. *Journal of Clinical and Experimental Neuropsychology*, 26, 5, 621–7.
- Arango, V., Ernsberger, P., Marzuk, P.M., Chen, J.S., Tierney, H., Stanley, M., Reis, D.J. and Mann, J.J. (1990). Autoradiographic demonstration of increased serotonin 5-HT₂ and beta-adrenergic receptor binding sites in the brain of suicide victims. *Archives of General Psychiatry*, 47, 1038–47.
- Ardila, A. (1995). Directions of research in cross-cultural neuropsychology. *Journal of Clinical and Experimental Neuropsychology*, 77, 1, 143–50.
- Ardila, A. and Moreno, S. (2001). Neuropsychological test performance in Aruaco Indians: an exploratory study. *Journal of the International Neuropsychological Society*, 7, 510–15.
- Arendt, T., Bigl, V., Arendt, A. and Tennstedt, A. (1983). Loss of neurons in the nucleus basalis of Meynert in Alzheimer's disease, paralysis agitans and Korsakoff's disease. *Acta Neuropathologica*, 61, 101–8.

- Armony, J.L., Servan-Scriber, D., Cohen, J.D. and LeDoux, J.E. (1997). Computational modelling of emotion: explorations through the anatomy and physiology of fear conditioning. *Trends in Cognitive Sciences*, 1, 1, 28–34.
- Armstrong, A. (2004). Differential diagnosis of toxic exposure. In J.H. Ricker (ed), *Differential Diagnosis in Adult Neuropsychological Assessment*. New York: Springer Publishing Company.
- Arora, R.C. and Meltzer, H.Y. (1989). Serotonergic measures in the brains of suicide victims: 5-HT₂ binding sites in the frontal cortex of suicide victims and control subjects. *American Journal of Psychiatry*, 146, 730–6.
- Arrigoni, G. and De Renzi, E. (1964). Constructional apraxia and hemispheric locus of lesion. *Cortex*, 1, 170–97.
- Artiola, I., Fortuny, L., Heaton, R.H. and Herosillo, D. (1998). Neuropsychological comparisons of Spanish speaking participants from the US–Mexico border region vs Spain. *Journal of the International Neuropsychological Society*, 4, 363–79.
- Aupee, A.M., Desgranges, B., Eustache, F., Lalevee, C. de la Sayette, V., Viader, F. and Baron, J.C. (2001). Voxel-based mapping of brain hypometabolism in permanent amnesia with PET. *Neuroimage*, 13, 1164–73.
- Averback, P. (1983). Two new lesions in Alzheimer's disease. *The Lancet*, 2, 1203.
- Averill, J.R. (1969). Autonomic response patterns during sadness and mirth. *Psychophysiology*, 5, 399–414.
- Awh, E., Jonides, J., Smith, E.E., Schumacher, E.H., Koeppel, R.A. and Katz, S. (1996). Dissociation of storage and rehearsal in verbal working memory. *Psychological Science*, 7, 25–31.
- Ayotte, J., Peretz, I. and Hyde, K. (2002). Congenital amusia: a group study of adults afflicted with a music-specific disorder. *Brain*, 125, 238–51.
- Azzopardi, P. and Cowey, A. (2001). Motion discrimination in cortically blind patients. *Brain*, 124, 30–46.
- Baars, M.L. and Kiernan, J.A. (1988) *The Human Nervous System*, fifth edition. Lippincott Williams & Wilkins.
- Baddeley, A.D. (1986). *Working Memory*. Oxford: Oxford University Press.
- Baddeley, A.D., Baddeley, H.A., Bucks, R.S. and Wilcock, G.K. (2001). Attentional control in Alzheimer's disease. *Brain*, 124, 1492–508.
- Baddeley, A.D. and Hitch, G.J. (1974). Working memory. In G.H. Bower (ed.), *The Psychology of Learning and Motivation: Advances in Research and Theory*, Vol. 8. New York: Academic Press.
- Baddeley, A.D. and Logie, R.H. (1992). Auditory imagery and working memory. In R.S. Nickerson (ed.), *Attention and Performance VIII*. Hillsdale, NJ: Lawrence Erlbaum.
- Badecker, W., Miozzo, M. and Zanuttini, R. (1995). The two-stage model of lexical retrieval: evidence from a case of anomia with selective preservation of grammatical gender. *Cognition*, 57, 193–216.
- Badner, J.A. and Gershon, E.S. (2002). Meta-analysis of whole-genome linkage scans of bipolar disorder and schizophrenia. *Molecular Psychiatry*, 7, 4, 405–11.
- Baker, K.B. and Kim, J.J. (2004). Amygdalar lateralization in fear conditioning: evidence for greater involvement of the right amygdala. *Behavioural Neuroscience*, 118, 1, 15–23.
- Baker, S.C., Rogers, R.D., Owen, A.M., Frith, C.D., Dolan, R.J., Frackowiak, R.S.J. and Robbins, T.W. (1996). Neural systems engaged by planning: a PET study of the Tower of London task. *Neuropsychologia*, 34, 6, 515–26.
- Bakker, D.J. (1986). Electrophysiological validation of L- and P-type dyslexia. *Journal of Clinical and Experimental Neuropsychology*, 8, 133.
- Bakker, D.J. (1990). Alleviation of dyslexia by stimulation of the brain. In G.T. Pavlidis (ed.), *Perspectives on Dyslexia*, Vol. 2. Chichester, UK: John Wiley & Sons.
- Bakker, D.J. (1992). Neuropsychological classification and treatment of dyslexia. *Journal of Learning Disabilities*, 25, 2, 102–9.
- Baldessarini, R.J. (1996a). Drugs and the treatment of psychiatric disorders: depression and mania. In J.G. Hardman and L.E. Limbird (eds), *Goodman and Gilman's The Pharmacological Basis of Therapeutics* (9th edition). New York: McGraw-Hill.
- Baldessarini, R.J. (1996b). Drugs and the treatment of psychiatric disorders: psychosis and anxiety. In J.G. Hardman and L.E. Limbird (eds), *Goodman and Gilman's The Pharmacological Basis of Therapeutics* (9th edition). New York: McGraw-Hill.
- Balint, R. (1909). Seelenhemmung des 'Schauens', optische Ataxie, räumliche Störungen des Aufmerksamkeits. *Monatsschrift für Psychiatrie und Neurologie*, 25, 51–81.
- Banich, M.T. (1995). Interhemispheric processing: theoretical considerations and empirical approaches. In R.J. Davidson and K. Hugdahl (eds), *Brain Asymmetry*. Cambridge, Mass.: MIT Press.
- Barnes, M.A. and Dennis, M. (2001). Knowledge-based inferencing after childhood head injury. *Brain and Language*, 76, 253–65.
- Barrett, K. (1993). Neurological Examination. In G. Morgan and S. Butler (eds), *Seminars in Basic Neurosciences*. London: Royal College of Psychiatrists.
- Barrett, S.E. and Shepp, B.E. (1988). Developmental changes in attentional skills: the effect of irrelevant variations on encoding and response selection. *Journal of Experimental Child Psychology*, 45, 382–99.
- Bartholomeus, B. (1974). Effects of task requirements on ear superiority for sung speech. *Cortex*, 10, 215–23.
- Basser, L. (1962). Hemiplegia of early onset and the faculty of speech with special reference to the effects of hemispherectomy. *Brain*, 85, 427–60.

- Bassett, A.S., Hodgkinson, K., Chow, E.W., Correia, S., Scutt, L.E. and Weksberg, R. (1998). 22q11 deletion syndrome in adults with schizophrenia. *American Journal of Medicine and Genetics*, 81, 4, 328–37.
- Basso, A., Burgio, F. and Faglioni, P. (2002). Long-term follow-up of ideomotor apraxia: a response to Cauraugh. *Neuropsychological Rehabilitation*, 12, 111–15.
- Basso, A., Burgio, F., Paulin, M. and Prandoni, P. (2000). Long-term follow-up of ideomotor apraxia. *Neuropsychological Rehabilitation*, 10, 1–13.
- Basso, A., Faglioni, P. and Vignolo, L.A. (1975). Etude contrôlée de la reeducation de langage dans l'aphasie: comparaison entre aphasiques traités et non-traités. *Revue Neurologie*, 131, 607–14.
- Basso, A., Spinnler, H., Vallar, G. and Zanobio, E.M. (1982). Left hemisphere damage and selective impairment of auditory-verbal short-term memory: a case study. *Neuropsychologia*, 20, 263–74.
- Bauer, R.M. (1984). Autonomic recognition of names and faces in prosopagnosia: a neuropsychological application of the guilty knowledge test. *Neuropsychologia*, 22, 457–69.
- Bauer, R.M. (1993). Agnosia. In K.M. Heilman and E. Valenstein (eds), *Clinical Neuropsychology* (3rd edition). New York: Oxford University Press.
- Baxter, L.R., Schwartz, J.M., Phelps, M.E., Mazziotta, J.C., Guze, B.H., Selin, C.E., Gerner, R.H. and Sumida, R.M. (1989). Reduction of prefrontal cortex glucose metabolism common to three types of depression. *Archives of General Psychiatry*, 46, 243–50.
- Bay, E. (1953). Disturbances of visual perception and their examination. *Brain*, 76, 515–50.
- Bayley, P.J., Salmon, D.P., Bondi, M.W., Bui, B.K., Olichney, J., Delis, D.C., Thomas, R.G. and Thal, L.J. (2000). Comparison of the serial position effect in very mild Alzheimer's disease, mild Alzheimer's disease, and amnesia associated with electroconvulsive therapy. *Journal of the International Neuropsychological Society*, 6, 290–8.
- Baylis, G.C., Baylis, L.L. and Gore, C.L. (2004). Visual neglect can be object-based or scene-based depending on task representation. *Cortex*, 40, 237–46.
- Bean, R.B. (1906). Some racial peculiarities of the negro brain. *American Journal of Anatomy*, 5, 353–432.
- Beardsall, L. (1998). Development of the Cambridge Contextual Reading Test for improving the estimation of premorbid verbal intelligence in older persons with dementia. *British Journal of Clinical Psychology*, 37, 229–40.
- Beardsall, L. and Brayne, C. (1990). Estimation of verbal intelligence in an elderly community: a prediction analysis using a shortened NART. *British Journal of Clinical Psychology*, 29, 83–90.
- Beaton, A.A. (1997). The relation of planum temporale asymmetry and morphology of the corpus callosum to handedness, gender and dyslexia: a review of the evidence. *Brain and Language*, in press.
- Beaton, A.A. (2002). Dyslexia and the cerebellar deficit hypothesis. *Cortex*, 38, 479–90.
- Beaton, A.A., Williams, L. and Moseley, L.G. (1994). Handedness and hand injuries. *British Journal of Hand Surgery*, 19B, 158–61.
- Beatty, J. (1995). *Principles of Behavioural Neuroscience*, New York: Brown and Benchmark/Williams C. Brown Communications Inc.
- Beatty, W.W., Rogers, C.L., Rogers, R.L., English, S., Testa, J.A., Orbelo, D.M., Wilson, D.A. and Ross, E.D. (1999). Piano playing in Alzheimer's disease: longitudinal study of a single case. *Neurocase*, 5, 459–69.
- Beauchamp, M.S., Cox, R.W. and DeYoe, E.A. (1997). Graded effects of spatial and featural attention on human area MT and associated motion-processing areas. *Journal of Neurophysiology*, 78, 5516–20.
- Beauvois, M.F. and Derouesne, J. (1981). Lexical or orthographic agraphia. *Brain*, 104, 21–49.
- Bebbington, P., Brugha, T., MacCarthy, B., Potter, J., Sturt, E., Wykes, T., Katz, R. and McGuffin, P. (1988). The Camberwell collaborative depression study I. Depressed probands: adversity and the form of depression. *British Journal of Psychiatry*, 152, 754–65.
- Bechara, A., Damasio, H., Tranel, D. and Damasio, A.R. (1997). Deciding advantageously before knowing the advantageous strategy. *Science*, 275, 1293–95.
- Bechara, A., Dolan, S., Denburg, N., Hinds, A., Anderson, S.W. and Nathan, P.E. (2001). Decision-making deficits, linked to a dysfunctional ventromedial prefrontal cortex, revealed in alcohol and stimulant abusers. *Neuropsychologia*, 39, 376–89.
- Bechara, A., Tranel, D. and Damasio, H. (2000). Characterization of the decision-making deficit of patients with ventromedial prefrontal cortex lesions. *Brain*, 123, 2189–202.
- Bechara, A., Tranel, D., Damasio, H. and Damasio, A.R. (1996). Failure to respond automatically to anticipated future outcomes following damage to prefrontal cortex. *Cerebral Cortex*, 6, 215.
- Beech, J.R. and Awaida, M. (1992). Lexical and non-lexical routes: a comparison between normally achieving and poor readers. *Journal of Learning Disabilities*, 25, 3, 196–206.
- Behrmann, M., Ebert, P. and Black, S. (2004). Hemispatial neglect and visual search: a large scale analysis. *Cortex*, 40, 247–63.
- Bender, M.D. and Feldman, M. (1972). The so-called 'visual agnosias'. *Brain*, 95, 173–86.
- Bender, S.D. and Rogers, R. (2004). Detection of neurocognitive feigning: development of a multi-strategy assessment. *Archives of Clinical Neuropsychology*, 19, 49–60.
- Benedict, R.H.B., Lockwood, A.H., Shucard, J.L., Shucard, D.W., Wack, D. and Murphy, B.W. (1998). Functional neuroimaging of attention in the auditory modality. *Neuroreport*, 9, 1, 121–26.

- Benson, D.F. (1967). Fluency in aphasia. *Cortex*, 3, 373–94.
- Benson, D.F. (1993). Aphasia. In K.M. Heilman and E. Valenstein (eds), *Clinical Neuropsychology*. New York: Oxford University Press.
- Benson, D.F. and Geschwind, N. (1985). The aphasias and related disturbances. In A.B. Baker and R.J. Joynt (eds), *Clinical Neurology*. New York: Harper & Row.
- Benson, D.F. and Weir, W.F. (1972). Acalculia: acquired arithmetria. *Cortex*, 8, 465–72.
- Bentin, S., Sahar, A. and Moscovitch, M. (1984). Intermanual information transfer in patients with lesions in the trunk of the corpus callosum. *Neuropsychologia*, 22, 601–11.
- Benton, A.L. (1990). Face recognition 1990. *Cortex*, 26, 491–9.
- Benton, A.L. (1994). Neuropsychological assessment. *Annual Review of Psychology*, 45, 1–23.
- Benton, A.L. and Hamsher, K. (1978). *The Multilingual Aphasia Examination*. Iowa City: University of Iowa Press.
- Benton, A.L. and Spreen, O. (1961). Visual memory test: the simulation of mental incompetence. *Archives of General Psychiatry*, 4, 79–83.
- Benton, A.L. and Van Allen, M.W. (1968). Impairment in facial recognition in patients with cerebral disease. *Cortex*, 4, 344–58.
- Berg, I.J., Koning-Haanstra, M. and Deelman, B.G. (1991). Long-term effects of memory rehabilitation: a controlled study. *Neuropsychological Rehabilitation*, 1, 97–111.
- Berger, H. (1929). Über das elektroencephalogramm des Menschen. *Arch. Psychiat. Nerv-Krankh.*, 87, 527–70.
- Bergqvist, T.F. and Malec, J.F. (1997). Psychology: Current practice and training issues in treatment of cognitive dysfunction. *Neurorehabilitation*, 8, 49–56.
- Berlin, C.I., Hughes, L.F., Lowe-Bell, S.S. and Berlin, H.L. (1973). Dichotic right ear advantage in children 5 to 13. *Cortex*, 9, 394–402.
- Berlin, H.A., Rolls, E.T. and Kischika, U. (2004). Impulsivity, time perception, emotion and reinforcement sensitivity in patients with orbitofrontal cortex lesions. *Brain*, 127, 1108–26.
- Bernard, L.C. (1990). Prospects for faking believable memory deficits on neuropsychological tests and the use of incentives in stimulation. *Journal of Clinical and Experimental Neuropsychology*, 12, 715–28.
- Berndt, R.S. and Caramazza, A. (1980). A redefinition of the syndrome of Broca's aphasia: implications for a neuropsychological model of language. *Applied Psycholinguistics*, 1, 255–78.
- Berndt, R.S. and Mitchum, R.S. (1995). *Cognitive Neuropsychological Approaches to the Treatment of Language Disorders*. Hove, UK: Lawrence Erlbaum.
- Berthier, M.L., Starkstein, S.E., Leiguarda, R., Ruiz, A., Mayberg, H.S., Wagner, H., Price, T.R. and Robinson, R.G. (1991). Transcortical aphasia. Importance of the nonspeech dominant hemisphere in language repetition. *Brain*, 114, 1409–27.
- Berti, A. and Rizzolatti, G. (1994). Is neglect a theoretically coherent unit? In P.W. Halligan and J.C. Marshall (eds), *Spatial Neglect: Position Papers on Theory and Practice*. Hove, UK: Lawrence Erlbaum.
- Best, M. and Demb, J.B. (1999). Normal planum temporale asymmetry in dyslexics with a magnocellular pathway deficit. *NeuroReport*, 10, 607–612.
- Bever, T.G. and Chiarello, R.J. (1974). Cerebral dominance in musicians and nonmusicians. *Science*, 185, 137–9.
- Bihrlé, A., Brownell, H. and Gardner, H. (1986). Comprehension of humorous and nonhumorous materials by left and right-brain damaged patients. *Brain and Cognition*, 5, 399–411.
- Bilder, R.M., Bogerts, B. and Ashtari, M. (1995). Anterior hippocampal volume reductions predict frontal dysfunction in first episode schizophrenia. *Schizophrenia Research*, 17, 47–58.
- Billingsley, R., McAndrews, M.P., Crawley, A.P. and Mikulis, D. (2001). Functional MRI of phonological and semantic processing in temporal lobe epilepsy. *Brain*, 124, 1218–27.
- Billingsley-Marshall, R.L., Simos, P.G. and Papanicolaou, A.C. (2004). Reliability and validity of neuroimaging techniques for identifying language-critical areas in children and adults. *Developmental Neuropsychology*, 26, 2, 541–63.
- Binnie, C.D., Channon, S. and Marston, D.L. (1991). Behavioural correlates of interictal spikes. In D. Smith, D. Treiman and M. Trimble (eds), *Neurobehavioural Problems in Epilepsy: Advances in Neurology*, Vol. 55. New York: Raven Press.
- Birbaumer, N., Grodd, W. and Diedrich, O. (1998). fMRI reveals amygdala activation to human faces in social phobics. *NeuroReport*, 9, 1223–6.
- Bird, C.M., Castelli, F., Malik, O., Frith, U. and Husain, M. (2004). The impact of extensive medial frontal lobe damage on 'theory of mind' and cognition. *Brain*, 127, 914–28.
- Bird, H. and Frankin, S. (1995/6). Cinderella revisited: a comparison of fluent and non-fluent aphasic speech. *Journal of Neurolinguistics*, 9, 187–206.
- Bird, H., Lambon Ralph, M.A., Seidenberg, M.S., McClelland, J.L. and Patterson, K. (2003). Deficits in phonology and past tense morphology: what's the connection? *Journal of Memory and Language*, 48, 3, 502–26.
- Bird, T.D. (1999). Clinical genetics of familial Alzheimer's disease. In R.D. Terry, R. Katzman, K.L. Bick and S.S. Sisodia (eds), *Alzheimer Disease* (2nd edition). Philadelphia: Lippincott Williams and Wilkins.
- Birkhill, W.R. and Schaie, K.W. (1975). The effect of differential reinforcement of cautiousness in intellectual performance among the elderly. *Journal of Gerontology*, 30, 578–83.
- Bisaga, A., Katz, J.L. and Antonini, A. (1998). Cerebral glucose metabolism in women with panic disorder. *American Journal of Psychiatry*, 155, 1178–83.

- Bisazza, A., Cantalupo, C., Robins, A., Rogers, L.J. and Vallortigara, G. (1996). Right-pawedness in toads. *Nature*, 379, 408.
- Bishop, D.V.M. (1983). Linguistic impairment after hemidecortication for infantile hemiplegia? A reappraisal. *Brain*, 85, 427–60.
- Bishop, D.V.M. (1990). *Handedness and Developmental Disorder*. Hove, UK: Lawrence Erlbaum.
- Bishop, D.V.M. (2002). Cerebellar abnormalities in developmental dyslexia: cause, correlate or consequence? *Cortex*, 38, 491–8.
- Bishop, D.V.M., Aamodt-Leeper, G., Creswell, C., McGurk, R. and Skuse, D.H. (2001). Individual differences in cognitive planning on the Tower of Hanoi task: neuropsychological maturity or measurement error? *Journal of Child Psychology and Psychiatry*, 42, 4, 551–6.
- Bisiach, E., Capitani, E., Luzzatti, C. and Perani, D. (1981). Brain and conscious representation of outside reality. *Neuropsychologia*, 19, 543–51.
- Bisiach, E. and Luzzatti, C. (1978). Unilateral neglect of representational space. *Cortex*, 14, 129–33.
- Bisiach, E., Pizzamiglio, L., Nico, D. and Antonucci, G. (1996). Beyond unilateral neglect. *Brain*, 119, 851–7.
- Bkorklund, A. (1992). Dopaminergic transplantation in experimental parkinsonism; cellular mechanisms of graft-induced functional recovery. *Current Opinion in Neurobiology*, 2, 683–89.
- Blair, C., Gamson, S., Thorne, S. and Baker, D. (2005). Rising mean IQ: cognitive demand of mathematics education for young children, population exposure to format schooling, and the neurobiology of the prefrontal cortex. *Intelligence*, 33, 1, 93–106.
- Blair, J.R. and Spreen, O. (1989). Predicting premorbid IQ: a revision of the National Adult Reading Test. *The Clinical Neuropsychologist*, 3, 129–36.
- Blair, R.J.R. and Cipolotti, L. (2000). Impaired social response reversal: a case of ‘acquired sociopathy’. *Brain*, 123, 1122–41.
- Blair, R.J.R., Morris, J.S., Frith, C.D., Perrett, D.I. and Dolan, R.J. (1999). Dissociable neural responses to facial expressions of sadness and anger. *Brain*, 122, 883–93.
- Blanke, O., Ortigue, S. and Landis, T. (2003). Colour neglect in an artist. *The Lancet*, 361, 264.
- Blansjaar, B.A. et al. (2000). Prevalence of dementia in centenarians. *International Journal of Geriatric Psychiatry*, 15, 219–25.
- Bliss, T. and Gardner-Medwin, A. (1973). Long-lasting potentiation of synaptic transmission in the dentate area of unanaesthetised rabbit following stimulation of the perforant path. *Journal of Physiology*, 232, 357–74.
- Blumer, D. and Benson, D.F. (1975). Personality changes with frontal and temporal lobe lesions. In D.F. Benson and D. Blumer (eds), *Psychiatric Aspects of Neurologic Disease*. New York: Grune and Stratton.
- Blumstein, S. (1981). Neurolinguistic disorders: language–brain relationships. In S. Filskov and T. Boll (eds), *Handbook of Clinical Neuropsychology*. New York: John Wiley & Sons.
- Blumstein, S. (1998). Phonological aspects of aphasia. In M.T. Sarno (ed.), *Acquired Aphasia*. San Diego: Academic Press.
- Blythe, I.M., Kennard, C. and Ruddock, K.H. (1987). Residual vision in patients with retinogeniculate lesions of the visual path. *Brain*, 110, 887–905.
- Bobes, M.A., Lopera, F., Garcia, M., Diaz-Comas, L., Galan, L. and Valdes-Sosa, M. (2003). Covert matching of unfamiliar faces in a case of prosopagnosia: an ERP study. *Cortex*, 39, 41–56.
- Bodamer, J. (1947). Die prosopagnosie. *Archiv für Psychiatrie und Zeitschrift für Neurologie*, 179, 6–54.
- Boder, E. (1973). Developmental dyslexia: a diagnostic approach based on three atypical reading–spelling patterns. *Developmental Medicine and Child Neurology*, 15, 663–87.
- Bogen, J.E. (1976). Language function in the short term following cerebral commissurotomy. In H. Avakian-Whitaker and H.A. Whitaker (eds), *Current Trends in Neurolinguistics*. New York: Academic Press.
- Bogen, J.E. (1993). The callosal syndromes. In K.M. Heilman and E. Valenstein (eds), *Clinical Neuropsychology*. New York: Oxford University Press.
- Boles, D.B. (1984). Sex in lateralised tachistoscopic word recognition. *Brain and Language*, 23, 2, 307–17.
- Bookheimer, S., Zeffin, T., Blaxton, T., Gaillard, W., and Theodore, W. (1995). Regional cerebral blood flow during object naming and word reading. *Human Brain Mapping*, 3, 93–106.
- Booth, J.R., MacWhinney, B., Thulborn, K.R., Sacco, K., Voyvodic, J.T. and Feldman, H.M. (2000). Developmental and lesion effects in brain activation during sentence comprehension and mental rotation. *Developmental Neuropsychology*, 18, 139–69.
- Bornstein, B., Sroka, H. and Munitz, H. (1969). Prosopagnosia with animal face agnosia. *Cortex*, 5, 164–9.
- Bornstein, R.A., Pakalannis, A., Drake, M.E. and Suga, L.J. (1988). Effects of seizure type and waveform abnormality on memory and attention. *Archives of Neurology*, 45, 884–7.
- Borod, J.C. (1992). Interhemispheric and intrahemispheric control of emotion: a focus on unilateral brain damage. *Journal of Consulting and Clinical Psychology*, 60, 3, 339–48.
- Borod, J.C., Koff, E. and Buck, R. (1986a). The neuropsychology of facial expression in normal and brain-damaged subjects. In P. Blanck, R. Buck and R. Rosenthal (eds), *Nonverbal Communication in the Clinical Context*. University Park: Pennsylvania State University Press.

- Borod, J.C., Koff, E. and Caron, H. (1983). Right hemispheric specialisation for the expression and appreciation of emotion: a focus on the face. In E. Perecman (ed.), *Cognitive Processing in the Right Hemisphere*. New York: Academic Press.
- Borod, J.C., Koff, E., Lorch, M.P. and Nicholas, M. (1986b). The expression and perception of facial emotion in brain-damaged patients. *Neuropsychologia*, 24, 345–8.
- Botez, M.I., Oliver, M., Vezina, J.-L., Botez, T. and Kaufman, B. (1985). Defective revisualization: dissociation between cognitive and imagistic thought. Case report and short review of the literature. *Cortex*, 21, 375–89.
- Bottini, G., Corcoran, R., Sterzi, R., Paulesu, E., Schenone, P., Scarpa, P., Frackowiak, R.S.J. and Frith, C.D. (1994). The role of the right hemisphere in the interpretation of figurative aspects of language. *Brain*, 117, 1241–53.
- Bourtchouladze, R., Abel, T., Berman, N., Gordon, R., Lapidus, K. and Kandel, E.R. (1998). Different training procedures recruit either one or two critical periods for contextual memory consolidation, each of which requires protein synthesis and PKA. *Learning and Memory*, 5, 365–74.
- Bowden, E.M. and Beeman, M.J. (1998). Getting the right idea: semantic activation in the right hemisphere. *Psychological Science*, 9, 6, 435–40.
- Bowen, D.M., Najlerahaim, A., Procter, A.W., Francis, P.T. and Murphy, E. (1989). Circumscribed changes in the cerebral cortex in neuropsychiatric disorders of later life. *Proceedings of the National Academy of Sciences of the USA*, 86, 9504–8.
- Bowers, D., Bauer, R.M., Coslett, H.B. and Heilman, K.M. (1985). Processing of faces by patients with unilateral hemisphere lesions. I: Dissociation between judgements of facial affect and facial identity. *Brain and Cognition*, 4, 258–72.
- Braak, H. and Braak, E. (1991). Neuropathological staging of Alzheimer-related changes. *Acta Neuropathologica*, 82, 239–59.
- Bradshaw, J.L. and Mattingley, J.B. (1995). *Clinical Neuropsychology: Behavioural and Brain Science*. London: Academic Press.
- Bradshaw, J.L. and Nettleton, N.C. (1981). The nature of hemispheric specialization in man. *Behavioural and Brain Sciences*, 4, 51–63.
- Bradshaw, J.L., Nettleton, N.C. and Taylor, M.J. (1981). Right hemisphere language and cognitive deficit in sinistrals? *Neuropsychologia*, 19, 113–32.
- Brady, S., Poggie, E. and Rapala, M.M. (1989). Speech repetition abilities in children who differ in reading skill. *Language and Speech*, 32, 2, 109–22.
- Brambilla, P. et al. (2003). GABAergic dysfunction in mood disorders. *Molecular Psychiatry*, 8, 721–37.
- Brandt, J. (1992). Detecting amnesia's impostors. In L.R. Squire and N. Butters (eds), *Neuropsychology of Memory*. New York: Guilford Press.
- Braus, D.F., Weber-Fahr, W., Tost, H., Ruf, M. and Henn, F.A. (2002). Sensory information processing in neuroleptic-naïve first-episode schizophrenic patients: a functional magnetic resonance imaging study. *Archives of General Psychiatry*, 59, 8, 696–701.
- Brazzelli, M., Colombo, N., Della Salla, S. and Spinnler, H. (1994). Spared and impaired cognitive abilities after bilateral frontal damage. *Cortex*, 30, 27–51.
- Breasted, J.H. (1930). *The Edwin Smith Surgical Papyrus*. Chicago: University of Chicago Press.
- Breillmann, R.S., Saling, M.M., Connell, A.B., Waites, A.B., Abbott, D.F. and Jackson, G.D. (2004). A high-field functional MRI study of quadri-lingual subjects. *Brain and Language*, 89, 531–42.
- Bremner, J.D., Narayan, M., Staib, L.H., Southwick, S.M., McGlashan, T. and Charney, D.S. (1999). Neural correlates of memories of childhood sexual abuse in women with and without posttraumatic stress disorder. *American Journal of Psychiatry*, 156, 1787–95.
- Bremner, J.D., Staib, L.H., Kaloupek, D., Southwick, S.M., Soufer, R. and Charney, D.S. (1999). Neural correlates of exposure to traumatic pictures and sound in Vietnam combat veterans with and without posttraumatic stress disorder. *Biological Psychiatry*, 45, 806–16.
- Bremner, J.D., Vythilingham, M. and Vermetten, E. (2003). Neural correlates of declarative memory for emotionally valenced words in women with posttraumatic stress disorder related to early childhood sexual abuse. *Biological Psychiatry*, 53, 879–89.
- Brewer, J.B., Zhao, Z., Desmond, J.E., Glover, G.H. and Gabrieli, J.D.E. (1998). Making memories: brain activity that predicts how well visual experience will be remembered. *Science*, 281, 1185–7.
- Brewin, C.R. (1988). *Cognitive Foundations of Clinical Psychology*. Hove, UK: Lawrence Erlbaum.
- Bright, P., Jaldow, E. and Kopelman, M.D. (2002). The National Adult Reading Test as a measure of premorbid intelligence: a comparison with estimates derived from demographic variables. *Journal of the International Neuropsychological Society*, 8, 847–54.
- Brion, S. and Jedynak, C.P. (1972). Troubles du transfert interhémisphérique a propos de 3 observations de tumeurs du corps calleux: la seigne de la main étrangère. *Revue Neurologie*, 126, 257–66.
- Brizzolara, D., Casalini, C., Montanaro, D. and Posteraro, F. (2003). A case of amnesia at an early age. *Cortex*, 39, 605–25.
- Broca, P.P. (1861) Remarques sur le siege de la faculté du langage articulé, suivies d'une observation d'aphémie. *Bulletin de la Société Anatomique*, 36, 330–57.

- Brodal, P. (1992). *The Central Nervous System: Structure and Function*. Oxford: Oxford University Press.
- Brodmann, K. (1909). *Vergleichende lokalisationlehr der grosshirnrinde in ihren prinzipien dargestellt auf grund des zellenbaues*. Leipzig: Barth.
- Broman, M. (1978). Reaction time differences between the left and right hemispheres for face and letter discrimination in children and adults. *Cortex*, 14, 578–91.
- Broman, M., Rose, A.L., Hotson, G. and McCarthy, C.C. (1997). Severe anterograde amnesia with onset in childhood as a result of anoxic encephalopathy. *Brain*, 120, 417–33.
- Brookshire, B.L., Chapman, S.B., Song, J. and Levin, H.S. (2000). Cognitive and linguistic correlates of children's discourse after closed head injury: a three-year follow-up. *Journal of the International Neuropsychological Society*, 6, 741–51.
- Brown, G.D.A., Hulme, C., Hyland, P.D. and Mitchell, I.J. (1994). Cell suicide in the developing nervous system: a functional neural network model. *Cognitive Brain Research*, 2, 71–5.
- Brown, H. and Kosslyn, S. (1993). Cerebral lateralization. *Current Opinion in Neurobiology*, 3, 183–6.
- Brown, P. (1980). An epidemiologic critique of Creutzfeldt–Jakob disease. *Epidemiology Review*, 2, 113–35.
- Brown, P. (2001). Effective treatments for mental illness are not being used, WHO says. *British Medical Journal*, 323, 769.
- Bruce, V., Henderson, Z., Greenwood, K., Hancock, P.J.B., Burton, A.M. and Miller, P. (1999). Verification of face identities from images captured on video. *Journal of Experimental Psychology: Applied*, 5, 339–60.
- Bruce, V. and Young, A. (1986). Understanding face recognition. *British Journal of Psychology*, 77, 305–27.
- Brun, A. (1987). Frontal lobe degeneration of non-Alzheimer type. I: Neuropathology. *Archives of Gerontology and Geriatrics*, 6, 193–208.
- Brunswick, N., McCrory, E., Price, C., Frith, C.D. and Frith, U. (1999). Explicit and implicit processing of words and pseudowords by adult developmental dyslexics: a search for Wernicke's Wortschatz? *Brain*, 122, 1901–17.
- Brunswick, N. and Rippon, G. (1994). Auditory event-related potentials, dichotic listening performance and handedness as indices of lateralisation in dyslexic and normal readers. *International Journal of Psychophysiology*, 18, 265–75.
- Bruyer, R., Laterre, C., Seron, X., Feyereisen, P., Strypstein, E., Pierrard, E. and Rectem, D. (1983). A case of prosopagnosia with some preserved covert remembrance of familiar faces. *Brain and Cognition*, 2, 257–89.
- Bryant, P.E., MacLean, M., Bradley, L.L. and Crossland, J. (1990). Rhyme and alliteration, phoneme detection, and learning to read. *Developmental Psychology*, 26, 3, 429–38.
- Bryden, M.P. (1965). Tachistoscopic recognition, handedness and cerebral dominance. *Neuropsychologia*, 3, 1–8.
- Bryden, M.P. and Allard, F.A. (1978). Dichotic listening and the development of linguistic processes. In M. Kinsbourne (ed.), *Asymmetrical Function of the Brain*. New York: Cambridge University Press.
- Bryden, M.P. and Lee, R.G. (1983). Right hemisphere involvement in imagery and affect. In E. Perecman (ed.), *Cognitive Processing in the Right Hemisphere*. New York: Academic Press.
- Bryden, M.P., McManus, I.C. and Bulman-Fleming, M.B. (1994). Evaluating the empirical support for the Geschwind–Behan–Galaburda model of cerebral lateralization. *Brain and Cognition*, 26, 103–67.
- Bub, D., Black, S., Hampson, E. and Kertesz, A. (1988). Semantic encoding of pictures and words: some neuropsychological observations. *Cognitive Neuropsychology*, 5, 27–66.
- Bub, D. and Kertesz, A. (1982). Deep agraphia. *Brain and Language*, 17, 1, 146–65.
- Büchel, C., Price, C., and Friston, K. (1998). A multimodal language region in the ventral visual pathway. *Nature*, 394, 274–77.
- Buck, L.B., Firestein, S. and Margolskee, R.F. (1994). Olfaction and taste in vertebrates: molecular and organizational strategies underlying chemosensory perception. In G.J. Siegel, B.W. Agranoff, R.W. Albers and P.B. Molinoff (eds), *Basic Neurochemistry*. New York: Raven Press.
- Bucy, P.C. (1934). The relation of the premotor cortex to motor activity. *Journal of Nervous and Mental Disorders*, 79, 621–30.
- Budson, A. E., Simons, J. S. Sullivan, A. L., Beier, J. S., Solomon, P. R., Scinto, L. F., Daffner, K. R., and Schacter, D. L. (2004). Memory and emotions for the 9/11/01 terrorist attacks in patients with Alzheimer's disease, mild cognitive impairment, and healthy older adults. *Neuropsychology*, 18, 315–27.
- Bulla-Hellwig, M., Vollmer, J., Gotzen, A., Skreczek, W. and Hartje, W. (1996). Hemispheric asymmetry of arterial blood flow velocity changes during verbal and visuospatial tasks. *Neuropsychologia*, 43, 10, 987–91.
- Bullock, R. (2002). New drugs for Alzheimer's disease and other dementias. *British Journal of Psychiatry*, 180, 135–9.
- Bunge, S.A., Dudukovic, N.M., Thomason, M.E., Vaidya, C.J. and Gabrieli, J.D. (2002). Immature frontal lobe contributions to cognitive control in children: Evidence from fMRI. *Neuron*, 33, 301–311.
- Bunge, S.A., Wedelken, C., Badre, D. and Wagner, A.D. (2005). Analogical reasoning and prefrontal cortex: evidence for separable retrieval and integration mechanisms. *Cerebral Cortex*, 15, 3, 239–49.
- Burgess, P.W., Veitch, E.J., Costello, A. de L. and Shallice, T. (2000). The cognitive and neuroanatomical

- cal correlates of multitasking. *Neuropsychologia*, 38, 848–63.
- Burke, D.M., MacKay, D.G., Worthley, J.S. and Wade, E. (1991). On the tip-of-the-tongue: what causes word finding failures in young and older adults? *Journal of Memory and Language*, 30, 542–79.
- Burt, T., Lisanby, S.H. and Sackheim, H.A. (2002). Neuropsychiatric applications of transcranial magnetic stimulation: a meta-analysis. *International Journal of Neuropsychopharmacology*, 5, 73–103.
- Burton, A.M., Bruce, V. and Johnston, R.A. (1990). Understanding face recognition with an interactive activation model. *British Journal of Psychology*, 81, 361–80.
- Burton, A.M., Young, A.W., Bruce, V., Johnston, R.A. and Ellis, A.W. (1991). Understanding covert recognition. *Cognition*, 39, 129–66.
- Butfield, E. and Zangwill, O.L. (1946). Re-education in aphasia: a review of 70 cases. *Journal of Neurology Neurosurgery and Psychiatry*, 9, 75–9.
- Butter, C.M. (1969). Perseveration in extinction and in discrimination reversal tasks following selective prefrontal ablations in Macaca mulatta. *Physiology and Behaviour*, 4, 163–71.
- Butter, C.M., Mark, V.W. and Heilman, K.M. (1988). An experimental analysis of factors underlying neglect in line bisection. *Journal of Neurology, Neurosurgery and Psychiatry*, 51, 1581–3.
- Butter, C.M. and Trobe, J.D. (1994). Integrative agnosia following progressive multifocal leukoencephalopathy. *Cortex*, 30, 145–58.
- Butters, N. (1985). Alcoholic Korsakoff's syndrome: some unresolved issues concerning etiology, neuropathology and cognitive deficits. *Journal of Clinical and Experimental Neuropsychology* 7, 2, 181–210.
- Butters, N., Albert, M., Sax, D., Miliotis, P., Nagode, J. and Sterste, A. (1983). Effect of verbal mediators on the pictorial memory of brain-damaged patients. *Neuropsychologia*, 21, 307–23.
- Butters, N., Barton, M. and Brody, B.A. (1970). Role of the right parietal lobe in the mediation of cross-modal associations and reversible operations in space. *Cortex*, 49, 174–90.
- Butters, N. and Cermak, L.S. (1980). *Alcoholic Korsakoff's Syndrome: An Information Processing Approach to Amnesia*. New York: Academic Press.
- Butters, N. and Stuss, D.T. (1989). Diencephalic amnesia. In F. Boller and J. Grafman (eds), *Handbook of Neuropsychology*. Amsterdam: Elsevier.
- Bystrinsky, A., Pontillo, D., Powers, M., Sabb, F.W., Craske, M.G. and Bookheimer, S.Y. (2001). Functional MRI changes during panic anticipation and imagery exposure. *Neuroreport*, 12, 3953–7.
- Cabeza, R. (2002). Hemispheric asymmetry reduction in older adults: the HAROLD model. *Psychology and Aging*, 17, 85–100.
- Cabeza, R., Grady, C.L., Nyberg, L., McIntosh, A.R., Tulving, E., Kapur, S., Jennings, J.M., Houle, S. and Craik, F.I.M. (1997). Age-related differences in neural activity during memory encoding and retrieval: a positron emission tomography study. *Journal of Neuroscience*, 17, 1, 391–400.
- Cabeza, R. and Nyberg, L. (2000). Imaging cognition II: an empirical review of 275 PET and fMRI studies. *Journal of Cognitive Neuroscience*, 12, 1, 1–47.
- Caccappoulo-van Vliet, E., Miozzo, M. and Stern, Y. (2004). Phonological dyslexia: a test case for reading models. *Psychological Science*, 15, 9, 583–90.
- Caesar, P. (1993). Old and new facts about perinatal brain development. *Journal of Child Psychology and Psychiatry*, 34, 101–09.
- Cahn, D.S., Sullivan, E.V., Shear, P.K., Marsh, L., Fama, R., Lim, K.O., Yesavage, J.A., Tinklenberg, J.R. and Pfefferbaum, A. (1998). Structural MRI correlates of recognition memory in Alzheimer's disease. *Journal of the International Neuropsychological Society*, 4, 106–14.
- Cahn, W., Pol, H.E., Lems, E.B., van Haren, N.E., Schnak, H.G. (2002). Brain volume changes in first-episode schizophrenia: a 1-year follow-up study. *Archives of General Psychiatry*, 59, 1, 1002–10.
- Calabrese, P., Markowitsch, H.J., Harders, A.G., Scholz, M. and Gehlen, W. (1995). Fornix damage and memory: a case report. *Cortex*, 31, 555–64.
- Calder, A.J., Keane, J., Lawrence, A.D. and Manes, F. (2004). Impaired recognition of anger following damage to the ventral striatum. *Brain*, 127, 1958–69.
- Callen *et al.* (2001). Beyond the hippocampus: MRI volumetry confirms widespread limbic atrophy in AD. *Neurology*, 57, 1669–74.
- Cameron, I., Curran, S., Newton, P. *et al.* (2000). Use of donepezil for the treatment of mild-moderate Alzheimer's disease: an audit of the assessment and treatment of patients in routine clinical practice. *International Journal of Geriatric Psychiatry*, 15, 887–91.
- Campaign, R. and Minckler, J. (1976). A note on the gross configurations of the human auditory cortex. *Brain and Language*, 3, 318–23.
- Campion, J., Latto, R. and Smith, Y.M. (1983). Is blindsight an effect of scattered light, spared cortex, and near-threshold vision? *Behavioural and Brain Science*, 6, 423–8.
- Cancro, R. (1989). Schizophrenia. In *Treatments of Psychiatric Disorders: A Task Force Report of the American Psychiatric Association*. Washington: APA.
- Canli, T., Desmond, J.E., Zhao, Z. and Gabriel, J.D.E. (2002b). Sex differences in the neural basis of emotional memories. *Proceedings of the National Academy of Sciences of the United States of America*, 99, 16, 10789–94.
- Canli, T., Sivers, H., Whitfield, S.L., Gotlib, I.H. and Gabrieli, J.D.E. (2002). Amygdala response to happy faces as a function of extraversion. *Science*, 296, 2191.

- Canli, T., Zhao, Z., Desmond, J.E., Kang, E., Gross, J. and Gabrieli, J.D.E. (2001). An fMRI study of personality influences on brain reactivity to emotional stimuli. *Behavioural Neuroscience*, 115, 1, 33–42.
- Cannistraro, P.A. and Rauch, S.L. (2003). Neural circuitry of anxiety: evidence from structural and functional neuroimaging studies. *Psychopharmacology Bulletin*, 37, 4, 8–25.
- Cantagallo, A. and Della Sala, S. (1998). Preserved insight in an artist with extrapersonal spatial neglect. *Cortex*, 34, 163–89.
- Caplan, D. (2002). Caramazza and Zurif's (1976) studies of aphasic patients with syntactic comprehension deficits. In Code, C., Wallech, C-W., Joannette, Y. and Lecours, A.R. (2002). *Classic Cases in Neuropsychology*, vol 2. Hove, UK: The Psychology Press.
- Caplan, P.J. and Kinsbourne, M. (1976). Baby drops the rattle: asymmetry of duration of grasp by infants. *Child Development*, 47, 532–4.
- Cappa, S.E., Perani, D., Grassi, E., Bressi, S., Albertoni, M., Franceschi, M. (1997). A PET follow-up study of recovery after stroke in acute aphasics. *Brain and Language*, 56, 55–67.
- Cappa, S.F., Sterzi, R., Vallar, G. and Bisiach, E. (1987). Remission of hemineglect and anosognosia during vestibular stimulation. *Neuropsychologia*, 25, 775.
- Caramazza, A. and Berndt, R.S. (1978). Semantic and syntactic processes in aphasia: a review of the literature. *Psychological Bulletin*, 85, 989–18.
- Caramazza, A. and Hillis, A. (1991). Lexical organization of nouns and verbs in the brain. *Nature*, 349, 788–90.
- Caramazza, A. and Shelton, J.R. (1998). Domain-specific knowledge systems in the brain: the animate–inanimate distinction. *Journal of Cognitive Neuroscience*, 10, 1–34.
- Caramazza, A. and Zurif, E.B. (1976). Dissociation of algorithmic and heuristic processes in language comprehension: evidence from aphasia. *Brain and Language*, 3, 572–82.
- Cardno, A.G., Rijdsdijk, F.V., Sham, P.C., Murray, R.M. and McGuffin, P. (2002). A twin study of genetic relationships between psychotic symptoms. *American Journal of Psychiatry*, 159, 4, 539–45.
- Carlson, N.R. (1986). *Physiology of Behavior* (3rd edition). Boston: Allyn & Bacon.
- Carlson, N.R. (1995). *Foundations of Physiological Psychology* (3rd edition). Boston: Allyn & Bacon.
- Carlsson, A. (1988). The current status of the dopamine hypothesis of schizophrenia. *Neuropsychopharmacology*, 1, 3, 179–86.
- Carlsson, K., Petrovic, P., Skare, S., Petersson, K.M. and Ingvar, M. (2000). Tickling expectations: neural processing in anticipation of a sensory stimulus. *Journal of Cognitive Neuroscience*, 12, 691–703.
- Carmichael, A. (1990). Physical development and biological influences. In B. Tonge, G.D. Burrows and J.S. Werry (eds), *Handbook of Studies in Child Psychiatry*. Amsterdam: Elsevier.
- Carney, N., Chenut, R.M., Maynard, H., Mann, N.C., Patterson, P. and Helfand, M. (1999). Effect of cognitive rehabilitation on outcomes for persons with traumatic brain injury: a systematic review. *Journal of Head Trauma Rehabilitation*, 14, 3, 277–307.
- Carpenter, W.T. and Buchanan, R.W. (1994). Schizophrenia. *New England Journal of Medicine*, 330, 10, 681–90.
- Carr, A.C., Wilson, S.L., Ancill, R.J., Ghosh, A. and Woods, R.T. (1982). Automated testing of geriatric patients using a micro-computer-based system. *International Journal of Man–Machine Studies*, 17, 3, 297–300.
- Carter, C.J., Benavides, J. and Dubois, A. (1989). The biochemistry of Huntington's chorea. In N.P. Quinn and P.G. Jenner (eds), *Disorders of Movement*. New York: Academic Press.
- Caselli, R.J. (1991). Bilateral impairment of somesthetically mediated object recognition in humans. *Mayo Clinical Proceedings*, 66, 357–64.
- Casey, M.B., Winner, E., Hurwitz, I. and DaSilva, D. (1991). Does processing style affect recall of Rey–Osterrieth or Taylor Complex Figures? *Journal of Clinical and Experimental Neuropsychology*, 13, 600–6.
- Castles, A. and Coltheart, M. (1993). Varieties of developmental dyslexia. *Cognition*, 47, 149–80.
- Castro-Caldas, A. and Silveira Bothelo, M. (1980). Dichotic listening in the recovery of aphasia after stroke. *Brain and Language*, 10, 145–51.
- Catafau, A.M., Perez, V., Gironell, A., Martin, J.C., Kulisevsky, J., Estorch, M., Carrio, I. and Alvarez, E. (2001). SPECT mapping of cerebral activity changes induced by repetitive transcranial magnetic stimulation in depressed patients. *Psychiatry Research*, 106, 151–60.
- Cedazo-Minguez, A. and Cowburn, R.F. (2001). Apolipoprotein E: a major piece in the Alzheimer's puzzle. *Journal of Cellular and Molecular Medicine*, 5, 254–66.
- Chance, S.A., Esiri, M.M. and Crow, T.J. (2002). Amygdala volume in schizophrenia: post-mortem study and review of magnetic resonance imaging findings. *British Journal of Psychiatry*, 180, 331–8.
- Chao, L.L. and Martin, A. (2000). Representation of manipulable man-made objects in the dorsal stream. *Neuroimage*, 12, 478–84.
- Chapman, A.J. (1976). Social aspects of humorous laughter. In A.J. Chapman and H.C. Foot (eds), *Humour and Laughter: Theory, Research and Applications*. Chichester, UK: John Wiley & Sons.
- Chapman, S.B., Levin, H.S., Wanek, A., Weyrauch, J. and Kufera, J.A. (1998). Discourse after closed head injury in young children. *Brain and Language*, 61, 420–49.

- Charney, D.S. and Bremner, J.D. (1999). Psychobiology of posttraumatic stress disorder. In S.N.E. Bunney and D.S. Charney (eds), *Neurobiology of Psychiatric Disorders*. New York: Oxford University Press.
- Chatterjee, A. (2004). Neuropsychology of art. *Neuropsychologia*, 42, 1568–83.
- Chayo-Dichy, R. and Ostrosky-Sollis, F. (1990). Neuroelectric correlates of dyslexia. *Revista Mexicana de Psicología*, 7, 1, 109–19.
- Chee, M.W., Tan, E.W., and Thiel, T. (1999). Mandarin and English single word processing studied with functional magnetic resonance imaging. *Journal of Neuroscience*, 19, 3050–66.
- Chelune, G.J. and Baer, R.A. (1986). Developmental norms for the Wisconsin Card Sorting Test. *Journal of Clinical Experimental Neuropsychology*, 8, 219–28.
- Chen, R., Classen, J., Gerloff, C., Celnik, P., Wassermann, E.M., Hallett, M. and Cohen, L.G. (1997). Depression of motor cortex excitability by low-frequency transcranial magnetic stimulation. *Neurology*, 48, 1398–403.
- Chi, J.G., Dooling, E.C. and Gilles, F.H. (1977). Gyri development of the human brain. *Annals of Neurology*, 1, 86–93.
- Chokron, S., Colliot, P. and Bartolomeo, P. (2004). The role of vision in spatial representation. *Cortex*, 40, 281–90.
- Christensen, A-L. (1979). *Luria's Neuropsychological Investigation* (2nd edition). Copenhagen: Ejnar Munksgaards Forlag.
- Christie, J., Shering, A., Ferguson, J. and Glen, A.I.M. (1981). Physostigmine and arecoline: effects of intravenous infusions in Alzheimer's presenile dementia. *British Journal of Psychiatry*, 138, 46–50.
- Chugani, H.T., Phelps, M.E. and Mazziotta, J.C. (1987). Positron emission tomography study of human brain functional development. *Annals of Neurology*, 22, 287–97.
- Cicerone, K.D. and Tanenbaum, L.N. (1997). Disturbance of social cognition after traumatic orbitofrontal brain injury. *Archives of Clinical Neuropsychology*, 12, 2, 173–88.
- Cipolotti, L. and Warrington, E.K. (1996). Does recognising orally spelled words depend on reading – an investigation into a case of better written than oral spelling. *Neuropsychologia*, 34, 5, 427–40.
- Clark, K.B., Naritoku, D.K., Smith, D.C., Browning, R.A. and Jensen, R.A. (1999). Enhanced recognition memory following vagus nerve stimulation in human subjects. *Nature Neuroscience*, 2, 94–8.
- Clark, R.E. and Squire, L.R. (1998). Classical conditioning and brain systems: the role of awareness. *Science*, 280, 77–81.
- Cloninger, C.R. (1986). A unified biosocial theory of personality and its role in the development of anxiety states. *Psychiatry and Development*, 3, 167–226.
- Cockburn, J., Keene, J., Hope, T. and Smith, P. (2000). Progressive decline in NART score with increasing dementia severity. *Journal of the International Neuropsychological Society*, 22, 508–17.
- Cohen, D.C., Peristein, W.M., Braver, T.S., Nystrom, L.E., Noll, D.C., Jonides, J. and Smith, E.E. (1997). Temporal dynamics of brain activation during a working memory task. *Nature*, 386, 604–8.
- Cohen, J. and Breslin, P.W. (1984). Visual evoked-responses in dyslexic children. *Annals of the New York Academy of Sciences*, 425, 338–43.
- Cohen, M.S. and Bookheimer, S.Y. (1994). Localization of brain function using magnetic resonance imaging. *Trends in Neurosciences*, 17, 7, 268–77.
- Cohen, N.J. and Squire, L.R. (1980). Preserved learning and retention of pattern analysing skill in amnesia: dissociation of knowing how and knowing that. *Science*, 210, 207–9.
- Colchester, A., Kingsley, D., Larserson, D., Kendall, B., Bello, F., Rush, C., Stevens, T.G., Goodman, G., Heilpern, N., Stanhope, N. and Kopelman, M.D. (2001). Structural MRI volumetric analysis in patients with organic amnesia: methods and comparative findings across diagnostic groups. *Journal of Neurology, Neurosurgery and Psychiatry*, 71, 13–22.
- Coltheart, M. (1980). Deep dyslexia: a right-hemisphere hypothesis. In M. Coltheart, K. Patterson and J.C. Marshall (eds), *Deep Dyslexia*. London: Routledge & Kegan Paul.
- Coltheart, M., Patterson, K. and Marshall, J.C. (1980). *Deep Dyslexia*. London: Routledge & Kegan Paul.
- Conel, J.L. (1939–67). *The Postnatal Development of the Human Cerebral Cortex*, 1–8. Cambridge, Mass.: Harvard University Press.
- Connolly, J.F. and Phillips, N. (1994). Event-related potential components reflect phonological and semantic processing of the terminal word of spoken sentences. *Journal of Cognitive Neuroscience*, 6, 3, 256–66.
- Conte, H.R. (1975). A circumplex model for personality traits. PhD dissertation, New York University.
- Cook, N.D. (1984a). The transmission of information in natural systems. *Journal of Theoretical Biology*, 108, 349–67.
- Cook, N.D. (1984b). Callosal inhibition: the key to the brain code. *Behavioural Science*, 29, 98–110.
- Cooper, L.A. and Shepard, R.N. (1973). Chronometric studies of the rotation of mental images. In W.G. Chase (ed.), *Visual Information Processing*. New York: Academic Press.
- Corballis, M.C. (1989). Laterality and human evolution. *Psychological Review*, 77, 451–64.
- Corballis, M.C. (1991). *The Lop-sided Ape*. New York: Oxford University Press.
- Corballis, M.C. (1997a). Mental rotation and the right hemisphere. *Brain and Language*, 57, 100–21.

- Corballis, M.C. (1997b). The genetics and evolution of handedness. *Psychological Review*, 104, 4, 714–27.
- Corballis, M.C. (1999). The gestural origins of language. *American Scientist*, 87, 138–45.
- Corballis, M.C. and Trudel, C.I. (1993). Role of the fore-brain commissures in interhemispheric integration. *Neuropsychologia*, 7, 306–24.
- Coren, S. (1989). Left handedness and accident-related risk. *American Journal of Public Health*, 79, 1040–1.
- Coren, S. and Halpern, D. (1991). Left-handedness: a marker for decreased survival fitness. *Psychological Bulletin*, 109, 1, 90–106.
- Corkin, S. (1978). The role of different cerebral structures in somesthetic perception. In C.E. Carterette and M.P. Friedman (eds), *Handbook of Perception*, Vol. VIB. New York: Academic Press.
- Cormack, A.M. (1963). Reconstruction of densities from their projections, with applications in radiological physics. *Physics, Medicine and Biology*, 18, 195–207.
- Cornier, P. and Stubbert, J.A. (1991). Instruction effects on gender differences in visual field advantages during lexical decision tasks. *Cortex*, 27, 3, 453–8.
- Corwin, J. and Bylsma, F.W. (1993). Translation of excerpts from Andre Rey's psychological examination of traumatic encephalopathy and P.A. Osterrieth's the Complex Figure Coy Test. *The Clinical Neuropsychologist*, 7, 3–15.
- Cossu, G., Daprati, E. and Marshall, J.C. (1995). Deep dyslexia and the right hemisphere hypothesis – spoken and written language after extensive left hemisphere lesion in a 12 year old boy. *Cognitive Neuropsychology*, 12, 4, 391–407.
- Cotzias, G.C., Papavasilou, P.S. and Gellene, R. (1967). L-Dopa in Parkinson's syndrome. *New England Journal of Medicine*, 281, 272–8.
- Coull, J.T., Frith, C.D., Frackowiak, R.S.J., and Grasby, P.M. (1996). A fronto-parietal network for rapid visual information processing: a PET study of sustained attention and working memory. *Neuropsychologia*, 34, 11, 1085–95.
- Coulson, S. (2000). *Semantic Leaps: Frame-shifting and Conceptual Blending in Nearing Construction*. New York and Cambridge: Cambridge University Press.
- Coulson, S. and Kutas, M. (2001). Getting it: human event-related brain response in good and poor comprehenders. *Neuroscience Letters*, 316, 71–4.
- Coulson, S. and Williams, R.F. (2005). Hemispheric asymmetries and joke comprehension. *Neuropsychologia*, 43, 128–41.
- Courtney, S.M., Ungerleider, L.G., Keil, K. and Haxby, J.V. (1997). Transient and sustained activity in a distributed neural system for human working memory. *Nature*, 386, 608–11.
- Cowan, W.M. (1979). The development of the brain. *Scientific American*, 241, 106–17.
- Cowburn, R.F., Hardy, J.A. and Roberts, P.J. (1990). Glutamatergic neurotransmission in Alzheimer's disease. *Biochemical Society Transactions*, 18, 390–2.
- Cowell, S.F., Egan, G.F., Code, C., Harasty, J. and Watson, J.D. (2000). The functional neuroanatomy of simple calculation and number repetition: a parametric PET activation study. *Neuroimage*, 12, 565–73.
- Cowey, A. (2004). The 30th Sir Frederick Bartlett lecture: fact, artefact, and myth about blindsight. *The Quarterly Journal of Experimental Psychology*, 57A, 4, 577–609.
- Craik, F.I.M. and Salthouse, T.A. (2000). *The Handbook of Aging and Cognition*. London: Lawrence Erlbaum.
- Crawford, J.R. (1992). Current and premorbid intelligence measures in neuropsychological assessment. In J.R. Crawford, D.M. Parker, and M.M. McKinlay (eds), *A Handbook of Neuropsychological Assessment*. Hove, UK: Lawrence Erlbaum.
- Crawford, J.R. (2004). Psychometric foundations of neuropsychological assessment. In L.H. Goldstein and J.E. McNeil (eds), *Clinical Neuropsychology: A Practical Guide to Assessment and Management for Clinicians*. Sussex, UK: John Wiley & Sons.
- Crawford, J.R., Allan, K.M., Jack, A.M., Morrison, F.M. and Parker, D.M. (1991). The short NART: cross-validation, relationship to IQ and some practical considerations. *British Journal of Clinical Psychology*, 30, 223–9.
- Crawford, J.R., Bryan, J., Luszcz, M.A., Obonsawin, M.C. and Stewart, L. (2000). The executive decline hypothesis of cognitive aging: do executive deficits qualify as differential deficits and do they mediate age-related memory decline? *Aging, Neuropsychology and Cognition*, 7, 1, 9–31.
- Crawford, J.R., Deary, I.J., Starr, J. and Whalley, L.J. (2001). The NART as an index of prior intellectual functioning: a retrospective validity study covering a 66-year interval. *Psychological Medicine*, 31, 451–8.
- Crawford, J.R., Garthwaite, P.H. and Gray, C.D. (2003). Wanted: fully operational definitions of dissociations in single-case studies. *Cortex*, 39, 357–70.
- Crawford, J.R., Gray, C.D. and Allan, K.M. (1995). The WAIS-R (UK): basic psychometric properties in an adult UK sample. *British Journal of Clinical Psychology*, 34, 237–50.
- Crawford, J.R. and Henry, J.D. (in press). Assessment of executive dysfunction. In P.W. Halligan and N. Wade (eds), *The Effectiveness of Rehabilitation for Cognitive Deficits*. London: Oxford University Press.
- Crawford, J.R., Henry, J.D., Ward, A.L. and Blake, J. (in press). The Prospective and Retrospective Memory Questionnaire (PMRQ): latent structure, normative data and discrepancy analysis for proxy-ratings. *British Journal of Clinical Psychology*.
- Crawford, J.R., Moore, J.W. and Cameron, I.M. (1992). Verbal fluency: a NART-based equation for the estimation

- of premorbid performance. *British Journal of Clinical Psychology*, 31, 327–29.
- Crawford, J.R., Obonsawin, M.C. and Allan, K.M. (1998). PASAT and components of WAIS-R performance: convergent and discriminant validity. *Neuropsychological Rehabilitation*, 8, 255–72.
- Crawford, J.R., Parker, D.M., Stewart, L.E., Besson, J.A.O. and DeLacey, G. (1989a). Prediction of WAIS IQ with the National Adult Reading Test: cross-validation and extension. *British Journal of Clinical Psychology*, 28, 267–83.
- Crawford, J.R., Smith, G.V., Maylor, E.A.M., Della Sala, S. and Logie, R.H. (2003). The Prospective and Retrospective Memory Questionnaire (PRMQ): normative data and latent structure in a large non-clinical sample. *Memory*, 1, 261–75.
- Crawford, J.R., Sommerville, J. and Robertson, I.H. (1997). Assessing the reliability and abnormality of subtest differences on the Test of Everyday Attention. *British Journal of Clinical Psychology*, 36, 609–18.
- Crawford, J.R., Stewart, L.E., Cochrane, R.H.B., Parker, D.M. and Besson, J.A.O. (1989b). Construct validity of the National Adult Reading Test: a factor analytic study. *Personality and Individual Differences*, 10, 585–7.
- Crawford, J.R. and Warrington, E.K. (2002). The Homophone Meaning Generation Test: psychometric properties and a method for estimating premorbid performance. *Journal of the International Neuropsychological Society*, 8, 547–54.
- Critchley, H.D. and Rolls, E.T. (1996). Hunger and satiety modify the responses of olfactory and visual neurons in the primate orbitofrontal cortex. *Journal of Neurophysiology*, 75, 1659–72.
- Critchley, M. (1973). *The Dyslexic Child* (2nd edition). London: Heinemann.
- Cronbach, L.J. (1949). *Essentials of Psychological Testing*. New York: Harper & Row.
- Cross, A.J., Crow, T.J., Johnson, J.A., Perry, E.K., Perry, R.H., Blessed, G. and Tomlinson, B.E. (1984). Studies on neurotransmitter receptor systems in neocortex and hippocampus in senile dementia of the Alzheimer type. *Journal of Neurological Sciences*, 64, 109–17.
- Crow, T.J. (1998). Nuclear schizophrenic symptoms as a window on the relationship between thought and speech. *British Journal of Psychiatry*, 173, 303–9.
- Crow, T.J. (2002). Handedness, language lateralisation and anatomical asymmetry: relevance of protocadherin XY to hominid speciation and the aetiology of psychosis. *British Journal of Psychiatry*, 181, 295–7.
- Cryan, J.F. and Kaupmann, K. (2005). Don't worry 'B' happy!: a role for GABA B receptors in anxiety and depression. *Trends in Pharmacological Sciences*, 26, 1, 36–43.
- Cubelli, R., Caselli, M. and Neri, N. (1984). Pain and unilateral cerebral lesions. *Cortex*, 20, 369–75.
- Cubelli, R. and Simoncini, L. (1997). Dissociation between word reading and word copying in a patient with left visual neglect. *Cortex*, 33, 177–85.
- Culham, J.C. and Kanwisher, N.G. (2001). Neuroimaging of cognitive functions in human parietal cortex. *Current Opinion in Neurobiology*, 11, 157–63.
- Cummings, J.L. and Benson, D.F. (1992). *Dementia: A Clinical Approach*. Boston: Butterworth.
- Cunningham, D.J. (1892). *Contributions to the Surface Anatomy of the Cerebral Hemispheres: Cunningham Memoires*, Vol. 7. Dublin: Royal Irish Academy.
- Curtiss, S. (1977). *Genie: A Psycholinguistic Study of a Modern Day 'Wild Child'*. New York: Academic Press.
- Damasio, A.R. (1989). Time-locked multiregional coactivation: a systems-level proposal for the neural substrates of recall and recognition. *Cognition*, 33, 25–62.
- Damasio, A.R. (1995). Toward a neurobiology of emotion and feeling: operational concepts and hypotheses. *The Neuroscientist*, 1, 1, 19–25.
- Damasio, A.R. (2000). A neural basis for sociopathy. *Archives of General Psychiatry*, 57, 128–9.
- Damasio, A.R., Chui, H.C., Corbett, J. and Kassel, N. (1980a). Posterior callosal section in a non-epileptic patient. *Journal of Neurology, Neurosurgery and Psychiatry*, 43, 351–6.
- Damasio, A.R. and Damasio, H. (1992). Brain and language. *Scientific American*, 267, 3, 62–71.
- Damasio, A.R., Damasio, H. and Van Hoesen, G.W. (1982). Prosopagnosia: anatomical basis and behavioural mechanisms. *Neurology*, 32, 331–41.
- Damasio, A.R., Tranel, D. and Damasio, H. (1990). Individuals with sociopathic behaviour caused by frontal damage fail to respond autonomously to social stimuli. *Behavioural Brain Research*, 41, 81–94.
- Damasio, A.R., Yamada, T., Damasio, H., Corbett, J. and McKee, J. (1980b). Central achromatopsia: behavioural, anatomic and physiologic aspects. *Neurology*, 30, 1064–71.
- Damasio, H. (1981). Cerebral localisation of the aphasias. In M.T. Sarno (ed.), *Acquired Aphasia*. New York: Academic Press.
- Damasio, H. and Damasio, A. (1980) The anatomical basis of conduction aphasia. *Brain*, 103, 337–50.
- Damasio, H. and Damasio, A. (1989). *Lesion Analysis in Neuropsychology*. New York: Oxford University Press.
- Damasio, H., Grabowski, T., Frank, R., Galaburda, A.M. and Damasio, A.R. (1994). The return of Phineas Gage: clues about the brain from the skull of a famous patient. *Science*, 264, 1102–5.
- Dane, S. and Bayirli, M. (1998). Correlations between hand preference and duration of hearing for right and left ears in young healthy subjects. *Perceptual and Motor Skills*, 86, 667–72.
- Daneman, M. and Carpenter, P.A. (1980). Individual differences in working memory and reading. *Journal of Verbal Learning and Verbal Behaviour*, 19, 450–66.

- Daniel, W.F. and Yeo, R.A. (1991). Handedness and accident proneness. *American Journal of Public Health*, 81, 1346.
- Darley, F.L. (1972). The efficacy of language rehabilitation in aphasia. *Journal of Speech and Hearing Disorders*, 30, 3–22.
- Dautrich, B.R. (1993). Visual perceptual differences in the dyslexic reader: evidence of greater visual peripheral sensitivity to color and letter stimuli. *Perceptual and Motor Skills*, 76, 755–64.
- Davidson, R.J. (1984). Affect, cognition, and hemispheric specialization. In C.E. Izard, J. Kagan and R. Zajonc (eds), *Emotion, Cognition and Behaviour*. New York: Cambridge University Press.
- Davidson, R.J. (1988). EEG measures of cerebral asymmetry: conceptual and methodological issues. *International Journal of Neuroscience*, 39, 71–89.
- Davidson, R.J. (1992). Anterior cerebral asymmetry and the nature of emotion. *Brain and Cognition*, 20, 125–51.
- Davidson, R.J. (2003). Affective neuroscience and psychophysiology: toward a synthesis. *Psychophysiology*, 40, 655–65.
- Davidson, R.J., Ekman, P., Saron, C.D., Senulis, J.A. and Friesen, W.V. (1990). Approach–withdrawal and cerebral asymmetry: emotional expression and brain physiology I. *Journal of Personality and Social Psychology*, 58, 2, 330–41.
- Davidson, R.J. and Fox, N.A. (1989). Frontal brain asymmetry predicts infants' response to maternal separation. *Journal of Abnormal Psychology*, 98, 2, 127–31.
- Davidson, R.J. and Schwartz, G.E. (1977). The influence of musical training on patterns of EEG asymmetry during musical and non-musical self-generation tasks. *Psychophysiology*, 14, 58–63.
- Davidson, R.J., Schwartz, G.E., Saron, C., Bennett, J. and Goleman, D.J. (1979). Frontal versus parietal EEG asymmetry during positive and negative affect. *Psychophysiology*, 16, 2, 202–3.
- Davidson, R.J. and Sutton, S.K. (1995). Affective neuroscience: the emergence of a discipline. *Current Opinion in Neurobiology*, 5, 2, 217–24.
- Davis, G.A. and Wilcox, M.J. (1981). Incorporating parameters of natural conversation aphasia treatment. In R. Chapey (ed.), *Language Intervention Strategies in Adult Aphasia*. Baltimore: Williams and Wilkins.
- Davis, H.P. and Bernstein, P.A. (1992). Age-related changes in explicit and implicit memory. In L.R. Squire and N. Butters (eds), *Neuropsychology of Memory*. New York: Guilford Press.
- Davis, H.P., Cohen, A., Gandy, M., Columbo, P., Van Dusseldorp, G., Simolke, N. and Romano, J. (1990). Lexical priming deficits as a function of age. *Behavioural Neuroscience*, 104, 288–97.
- Davis, H.P., Small, S.A., Stern, Y., Mayeux, R., Feldstein, S.N. and Keller, F.R. (2003). Acquisition, recall, and forgetting of verbal information in long-term memory by young, middle-aged and elderly individuals. *Cortex*, 39, 1063–91.
- Davitz, J.R. (1970). A dictionary and grammar of emotion. In M. Arnold (ed.), *Feelings and Emotions: The Loyola Symposium*. New York: Academic Press.
- Dax, M. (1865) Lesion de la moitié gauche de l'encephale coincidant avec l'oubli des signes de la pensée. *Gaz. hebdomadaire*, 2, 259–60.
- De Araujo, I.E.T., Kringelbach, M.L., Rolls, E.T. and McGlone, F. (2003). Human cortical responses to water in the mouth, and the effects of thirst. *Journal of Neurophysiology*, 90, 1865–76.
- De Armond, S.J., Fusco, M.M. and Dewey, M.M. (1989). *Structure of the Human Brain: A Photographic Atlas*. Oxford: Oxford University Press.
- Dehaene, S., Dupoux, E., Mehler, J., Cohen, L. and Paulesu, E. (1997). Anatomical variability in the cortical representation of first and second language. *NeuroReport*, 8, 3809–15.
- Dejerine, J. (1892). Contributions a l'étude anatomopathologique et clinique des différentes variétés de cécité verbale. *Comptes rendus des séances et mémoires de la Société de Biologie*, 44, 9, 61–90.
- Dekaban, A.S. and Sadowsky, D. (1978). Changes in brain weight during the span of human life: relation of brain weight to body heights and body weights. *Annals of Neurology*, 4, 345–56.
- De Kosky, S.T., Heilman, K.M., Bowers, M.D. and Valenstein, E. (1980). Recognition and discrimination of emotional faces and pictures. *Brain and Language*, 9, 206–14.
- De la Fuente-Fernandez, R and Stoessl, A.J. (2002). The placebo effect in Parkinson's disease. *Trends in Neurosciences*, 25, 302–6.
- Delaney, R.C., Rosen, A.J., Mattson, R.H. and Novelly, R.A. (1980). Memory function in focal epilepsy: a comparison of non-surgical unilateral temporal lobe and frontal samples. *Cortex*, 16, 103–17.
- Delay, J. (1935). *Les astereognosies: pathologie due toucher*. Paris: Masson.
- Delgado, P.L., Price, L.H., Miller, H.L., Salomon, R.M., Aghajanian, G.K., Heninger, G.R. and Charney, D.S. (1994). Serotonin and the neurobiology of depression. *Archives of General Psychiatry*, 51, 865–73.
- Delgado-Escuata, A.V., Treiman, D.M. and Walsh, G.O. (1983). The treatable epilepsies: Part I. *New England Journal of Medicine*, 308, 1508–14.
- Delis, D.C., Squire, L.R., Bihrlé, A. and Massman, P. (1992). Componential analysis of problem-solving ability: performance of patients with frontal lobe damage and amnesic patients on a new sorting task. *Neuropsychologia*, 30, 683–97.
- Dell, G.S. (2004). Connectionism and cognitive neuropsychology: comments on Harley's reflections. *Cognitive Neuropsychology*, 21, 1, 27–30.

- Dell, G.S. and Sullivan, J.M. (2004). Speech errors and language production: neuropsychological and connectionist perspectives. *The Psychology of Learning and Motivation*, 44, 63–108.
- Della Malva, C.L., Stuss, D.T., D'Alton, J. and Willmer, J. (1993). Capture errors and sequencing after frontal brain lesions. *Neuropsychologia*, 31, 4, 363–72.
- Della Salla, S., Marchetti, S. and Spinnler, H. (1991). Right-sided anarchic (alien) hand: a longitudinal study. *Neuropsychologia*, 29, 1113–27.
- Démonet, J.F., Chollet, F., Ramsay, S., Cardebat, D., Nespoulous, J.L., Wise, R., Rascol, A. and Frackowiak, R. (1992). The anatomy of phonological and semantic processing in normal subjects. *Brain*, 115, 1753–68.
- Demsky, Y.I., Gass, C.S. and Golden, C.J. (1998). Interpretation of VIQ–PIQ and intersubtest differences on the Spanish version of the WAIS. *Assessment*, 5, 25–30.
- Dennis, M. (1980). Capacity and strategy for syntactic comprehension after left or right hemidecortication. *Brain and Language*, 10, 287–317.
- Dennis, M. and Barnes, M.A. (2000). Speech acts after mild or severe head injury. *Aphasiology*, 14, 391–405.
- Dennis, M. and Barnes, M.A. (2001). Comparison of literal, inferential, and intentional text comprehension in children with mild or severe closed head injury. *Journal of Head Trauma Rehabilitation*, 16, 456–68.
- Dennis, M., Lovett, M. and Wiegel-Crump, C.A. (1981). Written language acquisition after left or right hemidecortication in infancy. *Brain and Language*, 12, 54–91.
- Dennis, M. and Whitaker, H.A. (1976). Language acquisition following hemidecortication: linguistic superiority of the left over the right hemisphere. *Brain and Language*, 3, 404–33.
- Dennis, M. and Whitaker, H.A. (1977). Hemispheric equipotentiality and language acquisition. In S.J. Segalowitz and F.A. Gruber (eds), *Language Development and Neurological Theory*. New York: Academic Press.
- De Renzi, E. (1982). *Disorders of Space Exploration and Cognition*. Chichester, UK: John Wiley & Sons.
- De Renzi, E. (1986a). Prosopagnosia in two patients with CT scan evidence of damage confined to the right hemisphere. *Neuropsychologia*, 24, 385–9.
- De Renzi, E. (1986b). Current issues in prosopagnosia. In H.D. Ellis, M.A. Jeeves, K.F. Newcombe and A. Young (eds), *Aspects of Face Processing*. Dordrecht: Martinus Nijhoff.
- De Renzi, E., Bonacini, M.G. and Faglioni, P. (1989). Right posterior brain damaged patients are poor at assessing the age of a face. *Neuropsychologia*, 27, 839–48.
- De Renzi, E. and Lucchelli, F. (1988). Ideational apraxia. *Brain*, 111, 1173–88.
- De Renzi, E. and Lucchelli, F. (1993). Dense retrograde amnesia, intact learning capability and abnormal forgetting rate: a consolidation deficit? *Cortex*, 29, 449–66.
- De Renzi, E., Periani, D., Carlesimo, G.A., Silveri, M.C. and Fazio, F. (1994). Prosopagnosia can be associated with damage confined to the right hemisphere: an MRI and PET study and a review of the literature. *Neuropsychologia*, 35, 8, 893–902.
- De Renzi, E., Pieczuro, A. and Vignolo, L.A. (1968). Ideational apraxia: a quantitative study. *Neuropsychologia*, 6, 41–52.
- De Renzi, E. and Saetti, M.C. (1997). Associative agnosia and optic aphasia: qualitative or quantitative difference? *Cortex*, 33, 115–30.
- De Renzi, E., Scotti, G. and Spinnler, H. (1969). Perceptual and associative disorders of visual recognition. *Neurology*, 19, 634–42.
- De Renzi, E. and Spinnler, H. (1967). Impaired performance on color tasks in patients with hemispheric damage. *Cortex*, 3, 194–216.
- De Renzi, E., Zambolin, A. and Crisi, G. (1987). The pattern of neuropsychological impairment associated with left posterior cerebral artery infarcts. *Brain*, 110, 1099–116.
- Desmond, J.E. (2001). Cerebellar involvement in cognitive function: evidence from neuroimaging. *International Review of Psychiatry*, 13, 283–94.
- D'Esposito, M., Aguirre, G.K., Zarahn, E., Ballard, D., Shin, R.K. and Lease, J. (1998). Functional MRI studies of spatial and nonspatial working memory. *Cognitive Brain Research*, 7, 1–13.
- D'Esposito, M., Postle, B.R., Ballard, D. and Lease, J. (1999). Maintenance versus manipulation of information held in working memory: an event-related fMRI study. *Brain and Cognition*, 41, 66–86.
- Desrocher, M.E., Smith, M.L. and Taylor, M.J. (1995). Stimulus and sex differences in performance of mental rotation: evidence from event-related potentials. *Brain and Cognition*, 28, 14–38.
- Deutsch, G., Bourbon, W.T., Papanicolaou, A.C. and Eisenberg, H.M. (1988). Visuospatial tasks compared via activation of regional cerebral blood flow. *Neuropsychologia*, 26, 445–52.
- Diamond, M.C. (1967). Extensive cortical depth measurements and neuron size increases in the cortex of environmentally enriched rats. *Journal of Comparative Neurology*, 131, 357–64.
- Dimond, S.J. (1976). Depletion of attentional capacity after total commissurotomy in man. *Brain*, 99, 347–56.
- Ditunno, P.L. and Mann, V.A. (1990). Right hemisphere specialization for mental rotation in normals and brain damaged subjects. *Cortex*, 26, 177–88.

- Djordjevic, J., Zatorre, R.J., Petrides, M., Boyle, J.A. and Jones-Gotman, M. (2005). Functional neuroimaging of odor imagery. *Neuroimage*, 24, 791–801.
- Dodrill, C.B. (1986). Correlates of generalized tonic-clonic seizures with intellectual, neuropsychological, emotional and social function in patients with epilepsy. *Epilepsia*, 27, 399–411.
- Donchin, E. and Coles, M.G.H. (1988). Is the P300 component a manifestation of context updating? *Behavioural and Brain Sciences*, 11, 357–74.
- Doty, R.L., Appelbaum, S., Zusho, H. and Settle, R.G. (1985). Sex differences in odor identification ability: a cross cultural analysis. *Neuropsychologia*, 23, 667–72.
- Drachman, D.A. and Leavitt, J. (1974). Human memory and the cholinergic system: a relationship to aging? *Archives of Neurology*, 25, 450–9.
- Dresser, A.C., Meierowsky, A.M., Weiss, G.H., McNeel, M.L., Simon, A.G. and Caveness, W.F. (1973). Gainful employment following head injury. *Archives of Neurology*, 29, 111–16.
- Drevets, W.C. (2001). Neuroimaging and neuropathological studies of depressions: implications for the cognitive-emotional features of mood disorders. *Current Opinion in Neurobiology*, 11, 240–9.
- Drevets, W.C., Price, J.L., Simpson, J.R., Todd, R.D., Reich, T., Vannier, M. and Raichle, M.E. (1997). Subgenual prefrontal cortex abnormalities in mood disorders. *Nature*, 386, 824–7.
- Drewe, E.A. (1974). The effect of type and area of brain lesion on Wisconsin Card Sorting Test performance. *Cortex*, 10, 159–70.
- Driscoll, I., McDaniel, M.A. and Gynn, M.J. (2005). Apolipoprotein E and prospective memory in normally aging adults. *Neuropsychology*, 19, 1, 28–34.
- Dronkers, N.F. (1996). A new brain region for coordinating speech articulation. *Nature*, 384, 159–61.
- Dronkers, N.F., Redfern, B.B., Van Valin, R.D., Redfern, B.B. and Jaeger, J.J. (1994). A reconsideration of the brain areas involved in the disruption of morphosyntactic comprehension. *Brain and Language*, 47, 461–3.
- Duan, H. *et al.* (2003). Age-related morphologic alterations in dendrites and spine densities of corticocortically projecting neurons in macaque monkeys. *Cerebral Cortex*, 13, 950–61.
- Duane, D.D. (1989). Commentary on dyslexia and neurodevelopmental pathology. *Journal of Learning Disabilities*, 22, 219–20.
- Duchaine, B. and Nakayama, K. (2005). Dissociations of face and object recognition in developmental prosopagnosia. *Journal of Cognitive Neuroscience*, 17, 2, 249–61.
- Duffau, H., Gatignol, P., Mandonnet, E., Peruzzi, P., Tzourio-Mazoyer, N. and Capelle, L. (2005). New insights into the anatomo-functional connectivity of the semantic system: a study using cortico-subcortical electrostimulations. *Brain*, 128, 797–810.
- Duffy, F.H., Denckla, M.B., Bartels, P.H., Sandini, G. and Kiessling, L.S. (1980). Dyslexia: automated diagnosis by computerised classification of brain electrical activity. *Annals of Neurology*, 7, 421–28.
- Duncan, H.J. and Smith, D.V. (1995). Clinical disorders of olfaction: a review. In R.L. Doty (ed.), *Handbook of Olfaction and Gustation*. New York: Marcel Dekker.
- Duncan, J. (1995). Attention, intelligence and the frontal lobes. In M.S. Gazzaniga (ed.), *The Cognitive Neurosciences*. Cambridge, Mass.: MIT Press.
- Duncan, J., Burgess, P. and Emslie, H. (1995). Fluid intelligence after frontal lobe lesions. *Neuropsychologia*, 33, 3, 261–8.
- Dusoir, H., Kapur, N., Byrnes, D.P., McKinstry, S. and Hoare, R.D. (1990). The role of diencephalic pathology in human memory disorder. *Brain*, 113, 1695–706.
- Eberstaller, O. (1890). Zur Oberflächenanatomie der Grosshirnhemisphären. *Wien. Med. Blätter*, 7, 479–82, 542–82, 644–6.
- Eckert, M.A., Leonard, C.M., Richards, T.L., Aylward, E.H., Thomson, J. and Berninger, V.W. (2003). Anatomical correlates of dyslexia: frontal and cerebellar findings. *Brain*, 126, 482–94.
- Ecuyer-Dab, I. and Robert, M. (2004). Have sex differences in spatial ability evolved from male competition for mating and female concern for survival. *Cognition*, 91, 221–57.
- Edelman, G.M. (1989). *Neural Darwinism*. Oxford: Oxford University Press.
- Eden, G.F., Stein, J.F. and Wood, F.B. (1993). Visuospatial ability and language processing in reading disabled and normal children. In S.F. Wright and R. Groner (eds), *Facets of Dyslexia and its Remediation*. Amsterdam: Elsevier.
- Eden, G.F., Stein, J.F., Wood, H.M. and Wood, F.B. (1994). Differences in eye movements and reading problems in dyslexic and normal children. *Vision Research*, 34, 10, 1345–58.
- Eden, G.F., VanMeter, J.W., Rumsey, J.M., Maisog, J.M., Woods, R.P. and Zeffiro, T.A. (1996). Abnormal processing of visual motion in dyslexia revealed by functional brain imaging. *Nature*, 382, 66–9.
- Efron, R. (1968). *What is Perception?* New York: Humanities Press.
- Ehrlichman, H. (1987). Hemispheric asymmetry and positive-negative affect. In D. Ottoson (ed.), *Duality and Unity of the Brain*. London: Macmillan.
- Eidelberg, D., Moeller, J.R., Antonini, A., Kazumata, K., Dhawan, V., Budman, C. and Feigin, A. (1997). The metabolic anatomy of Tourette's syndrome. *Neurology*, 48, 927–34.
- Ekman, P. (1973). Cross-cultural studies of facial expression. In P. Ekman (ed.), *Darwin and Facial Expression: A Century of Research in Review*. New York: Academic Press.

- Ekman, P. (1984). Expression and the nature of emotion. In K.R. Scherer and P. Ekman (eds), *Approaches to Emotion*. Hillsdale, NJ: Lawrence Erlbaum.
- Ekman, P., Davidson, R.J. and Friesen, W.V. (1990). The Duchenne smile: emotional expression and brain physiology II. *Journal of Personality and Social Psychology*, 58, 2, 342–53.
- Einstein, G.O., McDaniel, M.A., Smith, R.E. and Shaw, P. (1998). Habitual prospective memory and aging. *Psychological Science*, 9, 4, 284–8.
- Elfgren, C.I., Ryding, E. and Passant, U. (1996). Performance on neuropsychological tests related to single photon emission computerised tomography findings in frontotemporal dementia. *British Journal of Psychiatry*, 169, 416–22.
- Elliott, R., Frith, C.D. and Dolan, R.J. (1997). Differential neural response to positive and negative feedback in planning and guessing tasks. *Neuropsychologia*, 35, 10, 1395–404.
- Ellis, A.W., Lambon Ralph, M.A., Morris, J. and Hunter, A. (2000). Surface dyslexia: description, treatment and interpretation. In E. Funnell (ed.), *Case Studies in the Neuropsychology of Reading*. Hove, UK: Psychology Press.
- Ellis, A.W. and Young, A.W. (1996). *Human Cognitive Neuropsychology*. Hove, UK: Lawrence Erlbaum.
- Ellis, L. and Engh, T. (2000). Handedness and age of death: new evidence on a puzzling relationship. *Journal of Health Psychology*, 5, 4, 561–5.
- Ellis, N. and Large, B. (1988). The early stages of reading – a longitudinal study. *Applied Cognitive Psychology*, 2, 1, 47–76.
- Ellis, S.J., Ellis, P.J. and Marshall, E. (1988). Hand preference in a normal population. *Cortex*, 24, 157–63.
- Elman, J.L., Takahashi, K. and Tohsaku, Y.H. (1981). Lateral asymmetries for the identification of concrete and abstract Kanji. *Brain and Language*, 13, 290–300.
- Engelien, A., Huber, W., Silbersweig, D., Stern, E., Frith, C.D., Doring, W., Thron, A. and Frackowiak, R.S.J. (2000). The neural correlates of ‘deaf hearing’ in man. *Brain*, 123, 532–45.
- English, H.B. and English, A.C. (1958). *Comprehensive Dictionary of Psychological and Psychoanalytical Terms*. New York: Longmans Green.
- Erdal, K. (2004). The effects of motivation, coaching, and knowledge on neuropsychology on the simulated malingerer of head injury. *Archives of Clinical Neuropsychology*, 19, 73–88.
- Erickson, T.C. (1940). Spread of epileptic discharge. *Archives of Neurology and Psychiatry*, 43, 429–52.
- Esiri, M.M., Pearson, R.C.A., Steele, J.E., Bowen, D.M. and Powell, T.P.S. (1990). A quantitative study of the neurofibrillary tangles and the choline acetyltransferase activity in the cerebral cortex and amygdala in Alzheimer’s disease. *Journal of Neurology, Neurosurgery and Psychiatry*, 53, 161–5.
- Eskes, G.A., Szostak, C. and Stuss, D.T. (2003). Role of the frontal lobes in implicit and explicit retrieval tasks. *Cortex*, 39, 847–69.
- Eslinger, P.J. and Damasio, A.R. (1985). Severe disturbance of higher cognition after bilateral frontal ablation: patient EVR. *Neurology*, 35, 1731–41.
- Eslinger, P.J., Damasio, A.R. and Van Hoesen, G.W. (1982). Olfactory dysfunction in man: anatomical and behavioural aspects. *Brain and Cognition*, 1, 259–85.
- Eslinger, P.J. and Grattan, L.M. (1993). Frontal lobe and frontal – striatal substrates for different forms of human cognitive flexibility. *Neuropsychologia*, 31, 1, 17–28.
- Eslinger, P.J., Pepin, L. and Benton, A.L. (1988). Different patterns of visual memory errors occur with ageing and dementia. *Journal of Clinical and Experimental Neuropsychology*, 10, 60–1.
- Etkoff, N.K.L. (1984). Selective attention to facial identity and facial emotion. *Neuropsychologia*, 22, 281–95.
- Evans, D.A. *et al.* (1989). Prevalence of Alzheimer’s disease in a community population of older persons. Higher than previously reported. *Journal of the American Medical Association*, 262, 2551–6.
- Evans, J.J., Needham, P., Wilson, B.A. and Brentall, S. (2003). Which memory impaired people make good use of memory aids? Results of a survey of people with brain injury. *Journal of the International Neuropsychological Society*, 9, 925–35.
- Evans, M., Ellis, A., Watson, D. *et al.* (2000). Sustained cognitive improvement following treatment of Alzheimer’s disease with donepezil. *International Journal of Geriatric Psychiatry*, 15, 50–3.
- Farah, M.J. (1990). *Visual Agnosia: Disorders of Object Vision and What They Tell us about Normal Vision*. Cambridge, Mass.: MIT Press.
- Farah, M.J. (1991). Patterns of co-occurrence among the associative agnosias: implications for visual object representation. *Cognitive Neuropsychology*, 8, 1–19.
- Farah, M.J., O’Reilly, R.C. and Vecera, S.P. (1993). Dissociated overt and covert recognition as an emergent property of a lesioned neural network. *Psychological Review*, 100, 571–88.
- Farah, M.J., Rabinowitz, C., Quinn, G.E. and Liu, G.T. (2000). Early commitment of neural substrates for face recognition. *Cognitive Neuropsychology*, 17, 1/2/3, 117–23.
- Farah, M.J., Wilson, K.D., Drain, M. and Tanaka, J.N. (1998). What is ‘special’ about face perception? *Psychological Review*, 105, 482–98.
- Farrer, L.A., Cuppies, A., Haines, J.L., Hyman, B., Kukull, W.A., Mayeux, R. *et al.* (1997). Effects of age, sex and ethnicity on the association between apolipoprotein E genotype and Alzheimer disease. *Journal of the American Medical Association*, 278, 1349–56.

- Faulstich, M.E., McAnulty, D., Carey, M.P. and Gresham, F.M. (1987). Topography of human intelligence across race: factorial comparison of black–white WAIS-R profiles for criminal offenders. *International Journal of Neuroscience*, 35, 181–7.
- Faust, C. (1955). *Die zerebralen Herderscheinungen bei Hinterhauptverletzungen und ihre Beurteilung*. Stuttgart: Thieme Verlag.
- Fearnley, J.M. and Lees, A. (1991). Ageing and Parkinson's disease: substantia nigra regional selectivity. *Brain*, 114, 2283–301.
- Fellows, L.K. and Farah, M.J. (2005). Is anterior cingulate cortex necessary for cognitive control? *Brain*, 128, 788–96.
- Felton, R.H. and Wood, F.B. (1989). Cognitive deficits in reading disability and attention deficit disorder. *Journal of Learning Disabilities*, 1, 3–13.
- Fiebach, C.J., Friederici, A.D., Müller, K. and von Cramon, D.Y. (2002). fMRI evidence for dual routes to the mental lexicon in visual word recognition. *Journal of Cognitive Neuroscience*, 14, 11–23.
- Fields, R.B. (1998). The dementias. In P.J. Snyder and P.D. Nussbaum (eds), *Clinical Neuropsychology*. Washington: American Psychological Association.
- Fiez, J.A. (2000) Sound and meaning: how native language affects reading strategies. *Nature Neuroscience*, 3, 1, 3–5.
- Fiez, J.A. (1997). Phonology, semantics and the role of the left inferior prefrontal cortex. *Human Brain Mapping*, 5, 79–83.
- Fiez, J.A. and Petersen, S.E. (1998). Neuroimaging studies of word reading. *Proceedings of the National Academy of Sciences of the United States of America*, 95, 914–21.
- Fiez, J.A., Raichle, M.E., Miezin, F.M., Petersen, S.E., Tallal, P. and Katz, W.F. (1995). PET studies of auditory and phonological processing: effects of stimulus characteristics and task demands. *Journal of Cognitive Neuroscience*, 7, 3, 357–75.
- Fillenbaum, G.G., Heyman, A., Huber, M.S., Ganguli, M. and Unverzagt, F.W. (2001). Performance of elderly African American and white community residents on the CERAD neuropsychological battery. *Journal of the International Neuropsychological Society*, 7, 502–9.
- Filliter, J.H., McMullen, P.A. and Westwood, D. (2005). Manipulability and living/non-living category effects on object identification. *Brain and Cognition*, 57, 61–5.
- Fink, G.R., Halligan, P.W., Marshall, J.C., Frith, C.D., Frackowiak, R.S.J. and Dolan, R.J. (1996). Where in the brain does visual attention select the forest and the trees? *Nature*, 382, 626–8.
- Flannery, K.A. and Liederman, J. (1995). Is there really a syndrome involving the co-occurrence of neurodevelopmental disorder, talent, non-right handedness and immune disorder among children? *Cortex*, 31, 503–15.
- Fleischman, D.A. and Gabrieli, J.D.E. (1998). Repetition priming in healthy aging and Alzheimer's disease: a review of findings and theories. *Psychology and Aging*, 13, 88–119.
- Fleischman, D.A. and Gabrieli, J.D.E. (1999). Long-term memory in Alzheimer's disease. *Current Opinion in Neurobiology*, 9, 240–4.
- Fletcher, J. and Taylor, H.G. (1984). Neuropsychological approaches to children: towards a developmental neuropsychology. *Journal of Clinical Neuropsychology*, 6, 24–7.
- Fletcher, J.M. and Satz, P. (1985). Cluster analysis and the search for learning disability subtypes. In B. Rourke (ed.), *Neuropsychology of Learning Disabilities*. New York: Guilford Press.
- Fletcher, P.C., Frith, C.D., Grasby, P.M., Shallice, T., Frackowiak, R.S.J. and Dolan, R.J. (1995). Brain systems for encoding and retrieval of auditory – verbal memory. *Brain*, 118, 401–16.
- Fletcher, P.C. and Henson, R.N.A. (2001). Frontal lobes and human memory. *Brain*, 849–81.
- Fletcher, P.C., Shallice, T. and Dolan, R.J. (1998). The functional roles of prefrontal cortex in episodic memory. I. Encoding. *Brain*, 121, 1239–48.
- Fletcher, P.C., Shallice, T., Frith, C.D., Frackowiak, R.S. and Dolan, R.J. (1996). Brain activity during memory retrieval. The influence of imagery and semantic cueing. *Brain*, 119, 1587–96.
- Fletcher, P.C., Stephenson, C.M.E., Carpenter, T.A., Donovan, T. and Bullmore, E.T. (2003). Regional brain activations predicting subsequent memory success: an event-related fMRI study of the influence of encoding tasks. *Cortex*, 39, 1009–26.
- Flourens, P. (1824). *Récherches expérimentales sur les propriétés et les fonctions du système nerveux dans les animaux vertèbres*. Paris: Cervot.
- Flowers, D.L., Wood, F.B. and Naylor, C.E. (1991). Regional cerebral blood flow correlates of language processes in reading disability. *Archives of Neurology*, 48, 637–43.
- Fodor, J. (1983). *The Modularity of Mind*. Cambridge, Mass.: MIT Press.
- Fogassi, L., Ferrari, P.F., Gesierich, B., Rozzi, S., Chersi, F. and Rizzolatti, G. (2005). Parietal lobe: from action organization to intention understanding. *Science*, 308, 662–7.
- Folstein, S.E., (1989). *Huntington's Disease*. Baltimore: The Johns Hopkins University.
- Fortin, S., Godbout, L. and Braun, C.M.J. (2003). Cognitive structure of executive deficits in frontally lesioned head trauma patients performing activities of daily living. *Cortex*, 39, 273–91.
- Foundas, A., Macauley, B.L., Raymer, A.M., Maher, L.M., Heilman, K.M. and Rothi, L.J. (1995). Ecological implications of limb apraxia: evidence from mealtime behavior. *Journal of the International Neuropsychological Society*, 1, 62–6.

- Fox, N.A., Rubin, K.H., Calkins, S.D., Marshall, T.R., Coplan, R.J., Porges, S.W., Long, J.M. and Stewart, S. (1995). Frontal activation asymmetry and social competence at four years of age. *Child Development*, 66, 1770–84.
- Franco, L. and Sperry, R.W. (1977). Hemisphere lateralization for cognitive processing of geometry. *Neuropsychologia*, 15, 107–11.
- Frankland, P.W., Bontempi, B., Talton, L.E., Kaczmarek, L. and Silva, A.J. (2004). The involvement of the anterior cingulate cortex in remote contextual fear memory. *Science*, 304, 881–3.
- Franklin, S., Howard, D. and Patterson, K. (1994). Abstract word meaning deafness. *Cognitive Neuropsychology*, 11, 1–34.
- Franklin, S., van Sommers, P. and Howard, D. (1992). Drawing without meaning? Dissociations in graphic performance of an agnostic artist. In R. Campbell (ed.), *Mental Lives: Case Studies in Cognition*. Cambridge: Basil Blackwell.
- Frassinetti, F., Angeli, V., Meneghello, F., Avanzi, S. and Ladavas, E. (2002). Long-lasting amelioration of visuospatial neglect by prism adaptation. *Brain*, 125, 608–23.
- Freed, C.R., Breeze, R.E., Rosenberg, N.L., Schneck, S.A., Kriek, E., Qi, J.-X., Lone, T., Zhang, Y.-B., Snyder, J.A., Wells, T.H., Ramig, L., Thompson, L., Mazziotta, J.C., Huang, S.C., Grafton, S.T., Brooks, D., Sawle, G., Schroter, G. and Ansari, A.A. (1992). Survival of implanted fetal dopamine cells and neurologic improvement 12 to 46 months after transplantation for Parkinson's disease. *New England Journal of Medicine*, 327, 1549–55.
- Freed, C.R. et al. (2001). Transplantation of embryonic dopamine neurons for severe Parkinson's disease. *New England Journal of Medicine*, 344, 710–19.
- Freedman, M., Alexander, M.P. and Naeser, M.A. (1984). Anatomic basis of transcortical motor aphasia. *Neurology*, 34, 409–17.
- Freeman, W., Watts, J.W. and Hunt, T. (1942). *Psychosurgery*. Baltimore: Thomas.
- French, C.C. and Beaumont, J.G. (1987). The reaction of psychiatric patients to computerised assessment. *British Journal of Clinical Psychology*, 26, 267–78.
- Freud, S. (1891). *Zur Auffassung der Aphasien*. Vienna: Deuticke.
- Freund, D.C. (1889). Ueber optische Aphasie und Seelenblindheit. *Arch. Psychiatr. Nervenkr.*, 20, 276–97.
- Fried, I., Tanguay, P.E., Boder, E., Doubleday, C. and Greensite, M. (1981). Developmental dyslexia: electrophysiological evidence of clinical subgroups. *Brain and Language*, 12, 14–22.
- Friedland, R.P., Brun, A. and Budinger, T.F. (1985). Pathological and positron emission tomographic correlations in Alzheimer's disease. *The Lancet*, i, 228.
- Friedmann, N. and Nachman-Katz, I. (2004). Developmental neglect dyslexia in a Hebrew-reading child. *Cortex*, 40, 301–13.
- Frith, C.D. (1992). *The Cognitive Neuropsychology of Schizophrenia*. Hillsdale, NJ: Lawrence Erlbaum.
- Frith, C.D., Cahill, C., Ridley, R.M. and Baker, H.F. (1992). Memory for what it is and memory for what it means: a single case of Korsakoff's amnesia. *Cortex*, 28, 53–67.
- Frith, C.D., Friston, K.J., Liddle, P.F. and Frackowiak, R.S.J. (1991). A PET study of word finding. *Neuropsychologia*, 29, 1137–48.
- Frith, U. (1989). *Autism: Explaining the Enigma*. Oxford: Basil Blackwell.
- Fritsch, G. and Hitzig, E. (1870). Über die elektrische Erregbarkeit des Grosshirns. *Archiv für Anatomie, Physiologie und Wissenschaftliche Medizin*, 37, 300–32.
- Fromkin, V., Krashen, S., Curtiss, S., Rigler, S. and Rigler, M. (1972/73). The development of language in Genie: a case of language acquisition beyond the 'critical period'. *Brain and Language*, 1, 81–107.
- Frost, J.A., Binder, J.R., Springer, J.A., Hammeke, T.A., Belgawan, P.S.F., Rao, S.M. and Cox, R.W. (1999). Language processing is strongly left lateralised in both sexes. *Brain*, 122, 199–208.
- Fulton, J.F. (1928). Observations upon the vascularity of the human occipital lobe during visual activity. *Brain*, 51, 310–20.
- Furey, M.L., Pietrini, P. and Haxby, J.V. (2000). Cholinergic enhancement and increased selectivity of perceptual processing during working memory. *Science*, 290, 2315–19.
- Furry, C.A. and Baltes, P.B. (1973). The effect of age differences in ability extraneous performance variables on the assessment of intelligence in children, adults and the elderly. *Journal of Gerontology*, 28, 73–80.
- Gabrieli, J.D.E., Poldrack, R.A. and Desmond, J.E. (1998). The role of left prefrontal cortex in language and memory. *Proceedings of the National Academy of Sciences of the United States of America*, 95, 906–13.
- Gadian, D.G., Aicardi, J., Watkins, K.E., Porter, D.A., Mishkin, M. and Vargha-Kadem, F. (2000). Developmental amnesia associated with early hypoxic-ischaemic injury. *Brain*, 123, 499–507.
- Gainotti, G. (1994). The dilemma of unilateral spatial neglect. In P.W. Halligan and J.C. Marshall (eds), *Spatial Neglect: Position Papers on Theory and Practice*. Hove, UK: Lawrence Erlbaum.
- Gainotti, G. (2000). What the locus of brain lesion tells us about the nature of the cognitive defect underlying category-specific disorders: a review. *Cortex*, 36, 539–59.
- Galaburda, A.M. (1995). Anatomic basis of cerebral dominance. In R.J. Davidson and K. Hugdahl (eds), *Brain Asymmetry*. Cambridge, Mass.: MIT Press.

- Galaburda, A.M., Menard, M.T. and Rosen, G.D. (1994). Evidence for aberrant anatomy in developmental dyslexia. *Proceedings of the National Academy of Sciences*, 91, 8010–13.
- Galaburda, A.M., Sanides, F. and Geschwind, N. (1978). Human brain: cytoarchitectonic left–right asymmetries in the temporal speech region. *Archives of Neurology*, 35, 812–17.
- Galaburda, A.M., Sherman, G.F., Rosen, G.D., Aboitiz, F. and Geschwind, N. (1985) Developmental dyslexia: 4 consecutive patients with cortical anomalies. *Annals of Neurology*, 18, 2, 222–33.
- Galasko, D., Katzman, R., Salmon, D.P. and Hansen, L. (1996). Clinical and neuropathological findings in Lewy body dementias. *Brain and Cognition*, 31, 166–75.
- Gallagher, H.L. and Frith, C.D. (2003). Functional imaging of ‘theory of mind’. *Trends in Cognitive Science*, 7, 77–83.
- Gallo, J.M. and Anderton, B.H. (1989). Ubiquitous variations in nerves. *Nature*, 337, 1–14.
- Gardner, H., Ling, P.K., Flamm, L. and Silverman, J. (1975). Comprehension and appreciation of humorous material following brain damage. *Brain*, 98, 399–412.
- Garrard, P., Maloney, L.M., Hodges, J.R. and Patterson, K. (2005). The effects of very early Alzheimer’s disease on the characteristics of writing by a renowned author. *Brain*, 128, 250–60.
- Garruto, R.M. and Yase, Y. (1986). Neurodegenerative disorders of the western Pacific: the search for the mechanism of pathogenesis. *Trends in Neurosciences*, 9, 368–74.
- Gastaut, H. (1973). *Dictionary of Epilepsy*. Geneva: WHO.
- Gastaut, H., Gastaut, J.L., Gonclaves e Silva, G.E. and Fernandez Sanchez, G.R. (1975). Relative frequency of different types of epilepsy: a study employing the classification of the International League Against Epilepsy. *Epilepsia*, 16, 457–61.
- Gathercole, S.E. (1998). The development of memory. *Journal of Child Psychology and Psychiatry*, 39, 3–27.
- Gathercole, S.E., Willis, C. and Baddeley, A.D. (1991). Differentiating phonological memory and awareness of rhyme: reading and vocabulary development in children. *British Journal of Psychology*, 82, 387–406.
- Gatz, M., Pedersen, N.L., Berg, S., Johansson, B., Johansson, K., Mortimer, J.A., Posner, S.F., Viitanen, M., Winblad, B. and Ahlbom, A. (1997). Heritability for Alzheimer’s disease: the study of dementia in Swedish twins. *Journals of Gerontology Series A: Biological Sciences and Medical Sciences*, 52, 2, M117–M125.
- Gazzaniga, M.S., Bogen, J.E. and Sperry, R.W. (1962). Some functional effects of sectioning the cerebral commissures in man. *Proceedings of the National Academy of Sciences*, 48, 1765–9.
- Gazzaniga, M.S., Bogen, J.E. and Sperry, R.W. (1967). Dyspraxia following diversion of the cerebral commissures. *Archives of Neurology*, 16, 606–12.
- Gazzaniga, M.S. and Freedman, H. (1973). Observations on visual processes after posterior callosal section. *Neurology*, 23, 1126–30.
- Gazzaniga, M.S. and Hillyard, S.A. (1971). Language and speech capacity of the right hemisphere. *Neuropsychologia*, 9, 273–80.
- Geary, D.C. (1993). Mathematical disabilities: cognitive, neuropsychological and genetic components. *Psychological Bulletin*, 114, 2, 345–62.
- George, M.S., Wassermann, E.M., Williams, W.A., Steppel, J., Pascual-Leone, A., Basser, P., Hallett, M. and Post, R.M. (1996). Changes in mood and hormone levels after rapid-rate transcranial magnetic stimulation (rTMS) of the prefrontal cortex. *Journal of Neuropsychiatry and Clinical Neuroscience*, 8, 172–80.
- Georgiewa, P., Rzanny, R., Hopf, J., Knab, R., Glauche, V., Kaiser, W. and Blanz, B. (1999). fMRI during word processing in dyslexic and normal reading children. *NeuroReport*, 10, 3459–65.
- Gerlai, R. (2001). Behavioural tests of hippocampal function: simple paradigms complex problems. *Behavioural Brain Research*, 125, 269–77.
- Gernsbacher, M.A. and Kaschak, M.P. (2003). Neuroimaging studies of language production and comprehension. *Annual Review of Psychology*, 54, 91–114.
- Gerschberg, F.B. and Shimamura, A.P. (1995). Impaired use of organizational strategies in free recall following frontal lobe damage. *Neuropsychologia*, 33, 1305–33.
- Geschwind, N. (1965) Disconnexion syndromes in animals and man. *Brain*, 88, 237–94.
- Geschwind, N. and Behan, P. (1982). Left handedness: association with immune disease, migraine and developmental learning disorders. *Proceedings of the National Academy of Science*, 79, 5097–100.
- Geschwind, N. and Galaburda, A.M. (1985). Cerebral lateralization: biological mechanisms, associations, and pathology. Parts I, II and III. *Archives of Neurology*, 42, 428–59, 521–52, 634–54.
- Geschwind, N. and Galaburda, A.M. (1987). *Cerebral Lateralization*. Cambridge, Mass.: MIT Press.
- Geschwind, N. and Levitsky, W. (1968) Left–right asymmetries in temporal speech region. *Science*, 161, 186–7.
- Ghatan, P.H., Hsieh, J.C., Petersson, K.M., Stone-Elander, S. and Ingvar, M. (1998). Coexistence of attention-based facilitation and inhibition in the human cortex. *Neuroimage*, 7, 1, 23–9.
- Giedd, J.N., Blumenthal, J., Jeffries, N.O., Castellanos, F.X., Liu, H., Zijdenbos, A., Paus, T., Evans, A.C. and Rapoport, J.L. (1999). Brain development during childhood and adolescence: a longitudinal MRI study. *Nature Neuroscience*, 2, 10, 861–3.

- Giedd, J.N., Jeffries, N.O., Blumenthal, J., Castellanos, F.X. and Vaituzis, A.C. (1999). Childhood-onset schizophrenia: progressive brain changes during adolescence. *Biological Psychiatry*, 46, 7, 892–8.
- Giedd, J.N., Snell, J.W., Lange, N., Rajapakse, J.C., Casey, B.J., Kozuch, P.L., Vaituzis, A.C., Vauss, Y.C., Hamburger, S.D., Kaysen, D. and Rapoport, J.L. (1996). Quantitative magnetic resonance imaging of human brain development: ages 4–18. *Cerebral Cortex*, 6, 551–60.
- Gilbert, A.N. and Wysocki, C.J. (1992). Hand preference and age in the United States. *Neuropsychologia*, 30, 601–8.
- Gilboa, A., Winocur, G., Grady, C.L., Hevenor, S.J. and Moscovitch, M. (2004). Remembering our past: functional neuroanatomy of recollection of recent and very remote personal events. *Cerebral Cortex*, 14, 11, 1214–25.
- Giles, G.M. and Shore, M. (1989). The effectiveness of an electronic memory aid for a memory-impaired adult of normal intelligence. *American Journal of Occupational Therapy*, 43, 6, 409–11.
- Glisky, E.L. (1997). Rehabilitation of memory disorders: tapping into preserved mechanisms. *Brain and Cognition*, 35, 3, 291–2.
- Gloning, I., Gloning, K., Haub, G. and Quatember, R. (1969). Comparison of verbal behaviour in right-handed and non-right handed patients with anatomically verified lesion of one hemisphere. *Cortex*, 5, 43–52.
- Gloning, I. and Quatember, R. (1966). Methodischer Beitrag zur Untersuchung der Prosapagnosie. *Neuropsychologia*, 4, 133–44.
- Gloning, I., Trappl, R., Heiss, W.D. and Quatember, R. (1976). *Prognosis and Speech Therapy in Aphasia in Neurolinguistics*, Vol. 4, *Recovery in Aphasics*. Amsterdam: Swets and Zeitlinger.
- Glosser, G., Butters, N. and Kaplan, E. (1977). Visuo-perceptual processes in brain-damaged patients on the digit–symbol substitution test. *International Journal of Neuroscience*, 7, 59–66.
- Godefroy, O., Cabaret, N. and Rousseaux, M. (1994). Vigilance and effects of fatigability, practice and motivation on simple reaction time tests in patients with lesions of the frontal lobe. *Neuropsychologia*, 32, 983–90.
- Godefroy, O. and Rousseaux, M. (1996). Divided and focused attention in patients with lesion of the prefrontal cortex. *Brain and Cognition*, 30, 155–74.
- Goebel, R., Khorram-Sefat, D., Muckli, L., Hacker, H. and Singer, W. (1998). The constructive nature of vision: direct evidence from functional magnetic resonance imaging studies of apparent motion and motion imagery. *European Journal of Neuroscience*, 10, 1563–73.
- Goel, V. and Dolan, R.J. (2001). The functional anatomy of humor: segregating cognitive and affective components. *Nature Neuroscience*, 4, 237–8.
- Goel, V. and Dolan, R.J. (2004). Differential involvement of left prefrontal cortex in inductive and deductive reasoning. *Cognition*, 93, B109–B121.
- Goel, V., Gold, B., Kapur, S. and Houle, S. (1997). The seats of reason? An imaging study of deductive and inductive reasoning. *NeuroReport*, 8, 1305–10.
- Goel, V., Gold, B., Kapur, S. and Houle, S. (1998). Neuroanatomical correlates of human reasoning. *Journal of Cognitive Neuroscience*, 10, 3, 293–302.
- Gogtay, N., Giedd, J.N., Lusk, L., Hayashi, K.M., Greenstein, D., Vaituzis, A.C., Nugent, T.F., Herman, D.H., Clasen, D.H., Toga, A.W., Rapoport, J.L. and Thompson, P.M. (2004). Dynamic mapping of human cortical development during childhood through early adulthood. *Proceedings of the National Academy of Sciences*, 101, 21, 8174–9.
- Golbe, L.I., Iorio, G.D., Bonavita, V., Miller, D.C. and Duvoisin, R.C. (1990). A large kindred with autosomal dominant Parkinson's disease. *Annals of Neurology*, 27, 276–82.
- Golby, A., Silverberg, G., Race, E., Gabrieli, S., O'Shea, J., Knierim, K., Stebbins, G. and Gabrieli, J. (2005). Memory encoding in Alzheimer's disease: an fMRI study of explicit and implicit memory. *Brain*, 128, 773–87.
- Gold, S., Arndt, S., Johnson, D., O'Leary, D.S. and Andreasen, N.C. (1997). Factors that influence effect size in 15 O PET studies: a meta-analytic review. *Neuroimage*, 5, 280–91.
- Goldberg, E. (1989). Gradiational approach to neocortical functional organization. *Journal of Clinical and Experimental Neuropsychology*, 11, 4, 489–517.
- Golden, C.J., Hammeke, T.A. and Purisch, A.D. (1978). Diagnostic validity of a standardised neuropsychological battery derived from Luria's neuropsychological tests. *Journal of Consulting and Clinical Psychology*, 46, 1258.
- Golden, C.J., Hammeke, T.A. and Purisch, A.D. (1980). *Manual for the Luria–Nebraska Neuropsychological Battery*. Los Angeles: Western Psychological Services.
- Golden, C.J., Purisch, A.D. and Hammeke, T.A. (1980). *Luria–Nebraska Neuropsychological Battery: Forms I and II*. Los Angeles: Western Psychological Services.
- Golden, C.J., Hammeke, T., and Purisch, A. (1991). *The Luria–Nebraska Battery Manual*. New York: Raven Press.
- Goldman-Rakic, P.S. (1987). Circuitry of primate prefrontal cortex and regulation of behaviour by representational memory. In F. Plum (ed.), *Handbook of Physiology: The nervous system*, Vol. 5. Bethesda: American Physiology Society.
- Goldman-Rakic, P.S. (1988). Topography of cognition: parallel distributed networks in primate association cortex. *Annual Review of Neuroscience*, 11, 137–56.

- Goldman-Rakic, P.S. (1992). Working memory and the mind. *Scientific American*, 267, 3, 73–9.
- Goldman-Rakic, P.S. (1996). Multiple working memory domains and the concept of the central executive. In A.C. Roberts, T.W., Robbins, T.W. and L. Weiskrantz (eds), *Cognitive and Executive Functions of the Prefrontal Cortex*, *Philosophical Transactions: Biological Sciences*. London: Royal Society.
- Goldstein, J.H., Harman, J., McGhee, P.E. and Karasik, R. (1975). Test of an information-processing model of humor: physiological response changes during problem- and riddle-solving. *Journal of General Psychology*, 92, 59–68.
- Goldstein, K. (1936). The significance of the frontal lobes for mental performance. *Journal of Neurological Psychopathology*, 17, 27–40.
- Goldstein, K. (1939). *The Organism*. New York: Academic Press.
- Goldstein, K. and Scheerer, M. (1941). Abstract and concrete behaviour: an experimental study with special test. *Psychology Monographs*, 53, 2.
- Goldstein, L.H., Bernard, S., Fenwick, P.B.C., Burgess, P.W. and McNeil, J. (1993). Unilateral frontal lobectomy can produce strategy application disorder. *Journal of Neurology, Neurosurgery and Psychiatry*, 56, 274–6.
- Gollin, E.S. (1960). Developmental studies of visual recognition of incomplete objects. *Perceptual and Motor Skills*, 11, 289–98.
- Goodale, M.A., Meenan, J.P., Bulthoff, H.H., Nicolle, D.A., Murphy, K.J. and Racioc, C.I. (1994). Separate neural pathways for the visual analysis of object shape in perception and prehension. *Current Biology*, 4, 604–10.
- Goodale, M.A. and Milner, A.D. (1992). Separate visual pathways for perception and action. *Trends in Neuroscience*, 15, 20–5.
- Goodale, M.A., Milner, A.D., Jakobson, L.S. and Carey, D.P. (1991). Perceiving the world and grasping it: a neurological dissociation. *Nature*, 349, 154–6.
- Goodglass, H. (1976) Agrammatism. In H. Whitaker and H.A. Whitaker (eds), *Studies of Neurolinguistics*. New York: Academic Press.
- Goodglass, H. (1993). *Understanding Aphasia*. New York: Academic Press.
- Goodglass, H. and Kaplan, E. (1972). *The Assessment of Aphasia and Related Disorders*. Philadelphia: Lea & Febiger.
- Goodglass, H. and Kaplan, E. (1983). *The assessment of aphasia and related disorders* (2nd edition). Philadelphia: Lea and Febiger.
- Goodglass, H., Kaplan, E., and Barresi, B. (2001). *The assessment of aphasia and related disorders*. Philadelphia: Lippincott Williams and Wilkins.
- Goodglass, H. and Quadfasel, F.A. (1954). Language laterality in left-handed aphasics. *Brain*, 77, 521–48.
- Gordon, H.W. (1980). Degree of ear asymmetries for perception of dichotic chords for illusory chord localization in musicians of different levels of competence. *Journal of Experimental Psychology: Human Perception and Performance*, 6, 516–27.
- Gordon, H.W. and Sperry, R.W. (1969). Lateralization of olfactory perception in the surgically separated hemispheres of man. *Neuropsychologia*, 7, 111–20.
- Gorell, J.M. *et al.* (1999). Smoking and Parkinson's disease: a dose–response relationship. *Neurology*, 52, 115–19.
- Gorno-Tempini, M.L. and Price, C.J. (2001). Identification of famous faces and buildings: a functional neuroimaging study of semantically unique items. *Brain*, 124, 2087–97.
- Gorno-Tempini, M.L., Price, C.J., Josephs, O., Vandenberghe, R., Cappa, S.F., Kapur, N. and Frackowiak, R.S.J. (1998). The neural systems sustaining face and proper-name processing. *Brain*, 121, 2103–18.
- Gott, P.S. (1973). Language after dominant hemispherectomy. *Journal of Neurology, Neurosurgery and Psychiatry*, 36, 1082–8.
- Gottesman, I.I. (1991). *Schizophrenia Genesis: The Origins of Madness*. New York: W.H. Freeman.
- Gottesman, I.I. and Shields, J. (1982). *Schizophrenia: The Epigenetic Puzzle*. Cambridge: Cambridge University Press.
- Gottfries, C.G. (1990). Neurochemical aspects of dementia disorders. *Dementia*, 1, 56–64.
- Gowers, W.R. (1887). *Lectures on the Diagnosis of Diseases of the Brain*. London: Churchill.
- Grady, C.L. and Craik, F.I.M. (2000). Changes in memory processing with age. *Current Opinion in Neurobiology*, 10, 224–31.
- Grady, C.L., McIntosh, A.R., Bookstein, F., Horwitz, B., Rapoport, S.I. and Haxby, J.V. (1998). Age-related changes in regional cerebral blood flow during working memory for faces. *Neuroimage*, 8, 409–425.
- Grady, C.L., McIntosh, A.R., Horwitz, B., Maisog, J.M., Ungerleider, L.G. and Mentis, M.J. (1995). Age-related reductions in human recognition memory due to impaired encoding. *Science*, 269, 218–21.
- Graf, P., Squire, L.R. and Mandler, G. (1984). The information that amnesic patients do not forget. *Journal of Experimental Psychology: Learning, Memory, and Cognition*, 10, 164–78.
- Grafman, J., Jones, B. and Salazar, A. (1990). Wisconsin Card Sorting Test performance based on location and size of neuroanatomical lesions in Vietnam veterans with penetrating head injuries. *Perceptual and Motor Skills*, 71, 1120–2.
- Graham, J.E., Rockwood, K., Beattie, B.L., Eastwood, R., Gauthier, S., Tuokko, H. and McDowell, I. (1997).

- Prevalence and severity of cognitive impairment with and without dementia in an elderly population. *The Lancet*, 349, 1793–96.
- Grailet, J.M., Seron, X., Bruyer, R., Coyette, F. and Frederix, M. (1990). Case report of visual integrative agnosia. *Cognitive Neuropsychology*, 7, 275–309.
- Grandjean, D., Sander, D., Pourtois, G., Schwartz, S., Seghier, M.L., Schere, K.R. and Vuilleumier, P. (2005). The voices of wrath: brain responses to angry prosody in meaningless speech. *Nature Neuroscience*, 8, 145–6.
- Grant, D.A. and Berg, E.A. (1948). A behavioural analysis of degree of reinforcement and ease of shifting to new responses in a Weigl-type card sorting problem. *Journal of Experimental Psychology*, 38, 404–11.
- Grant, S., Contoreggi, C. and London, E.D. (2000). Drug abusers show impaired performance in a laboratory test of decision-making. *Neuropsychologia*, 38, 1180–7.
- Gray, J.A. (1982). *The Neuropsychology of Anxiety: An Enquiry into the Septo-hippocampal System*. Oxford: Oxford University Press.
- Gray, J.A. (1995). A model of the limbic system and basal ganglia: applications to anxiety and schizophrenia. In M.S. Gazzaniga (ed.), *The Cognitive Neurosciences*. Cambridge, Mass.: MIT Press.
- Gray, J.A. and McNaughton, N. (2000). *The neuropsychology of anxiety* (2nd edition). Oxford: Oxford University Press.
- Gray, J.M., Young, A.W., Barker, W.A., Curtis, A. and Gibson, D. (1997). Impaired recognition of disgust in Huntington's disease gene carriers. *Brain*, 120, 2029–38.
- Green, G.L. and Lessell, S. (1977). Acquired cerebral dyschromatopsia. *Archives of Ophthalmology*, 95, 121–8.
- Greenberg, B.D., Li, Q., Lucas, F.R., Hu, S., Sirota, L.A. and Benjamin, J. (2000). Association between the serotonin transporter promoter polymorphism and personality traits in primarily a female population sample. *American Journal of Medical Genetics*, 96, 2, 202–16.
- Greene, J.D.W. and Hodges, J.R. (1996a). Identification of famous faces and famous names in early Alzheimer's disease. *Brain*, 119, 111–28.
- Greene, J.D.W. and Hodges, J.R. (1996b). Identification of remote memory: evidence from a longitudinal study of dementia of Alzheimer type. *Brain*, 119, 129–42.
- Grisaru, N., Amir, M., Cohen, H. and Caplan, Z. (1998). Effect of transcranial magnetic stimulation in posttraumatic stress disorder: a preliminary study. *Biological Psychiatry*, 44, 52–5.
- Grisaru, N., Bruno, R. and Pridmore, S. (2001). Effect on emotion of healthy individuals of slow repetitive transcranial magnetic stimulation applied to the prefrontal cortex. *Journal of ECT*, 17, 184–9.
- Grisaru, N., Chudakov, B., Yaroslavsky, Y. and Belmaker, R.H. (1998). Transcranial magnetic stimulation in mania: a controlled study. *American Journal of Psychiatry*, 155, 1608–10.
- Grossi, G., Semenza, C., Corazza, S. and Volterra, V. (1996). Hemispheric specialization for sign language. *Neuropsychologia*, 34, 7, 737–40.
- Grünling, C., Ligges, M., Huonker, R., Klingert, M., Mentzel, H.-J., Rzanny, R., Kaiser, W.A., Witte, H. and Blanz, B. (2004). Dyslexia: the possible benefit of multimodal integration of fMRI and EEG data. *Journal of Neural Transmission*, 111, 951–69.
- Guan, Z.Z. et al. (2002). Selective changes in the levels of nicotinic acetylcholine receptor protein and of corresponding mRNA species in the brains of patients with Parkinson's disease. *Brain Research*, 956, 358–66.
- Guariglia, C., Padovani, A., Pantano, P. and Pizzamiglio, L. (1993). Unilateral neglect restricted to visual imagery. *Nature*, 364, 235–7.
- Gur, R.C. and Gur, R.E. (1995). Hypofrontality in schizophrenia: RIP. *The Lancet*, 345, 1383–85.
- Gur, R.C., Gur, R.E., Orbist, W.D., Skolnick, B.E. and Reivich, M. (1987). Age and regional cerebral blood flow at rest and during cognitive activity. *Archives of General Psychiatry*, 44, 617–21.
- Gur, R.C., Ragland, J.D., Resnick, S.M., Skolnick, B.E., Jaggi, J., Muenz, L. and Gur, R.E. (1994). Lateralised increases in cerebral blood flow during performance of verbal and spatial tasks: relationship with performance level. *Brain and Cognition*, 24, 244–58.
- Gurland, B.J. (1981). The borderland of dementia: the influence of socio-cultural characteristics on rates of dementia occurring in the senium. *Ageing*, 15, 61–84.
- Habel, U., Klein, M., Kellermann, T., Shah, N.J. and Schneider, F. (2005). Same or different? Neural correlates of happy and sad mood in healthy males. *Neuroimage*, 26, 1, 206–14.
- Haber, S.N., Kowall, N.W., Vonsattel, J.P., Bird, E.D. and Richardson, E.P. (1986). Gilles de la Tourette's syndrome: a postmortem neuropathological and immunohistochemical study. *Journal of the Neurological Sciences*, 75, 225–41.
- Hadziselimovic, H. and Cus, M. (1966). The appearance of the internal structures of the brain in relation to the configuration of the human skull. *Acta Anatomica*, 63, 289–99.
- Hagberg, B. et al. (2001). Cognitive functioning in centenarians: a coordinated analysis of results from three countries. *Journal of Gerontology*, 56, 141–51.
- Hagemann, D., Naumann, E., Thayer, J.F. and Bartussek, D. (2002). Does resting electroencephalograph asymmetry reflect a trait? An application of latent state-trait theory. *Journal of Personality and Social Psychology*, 82, 4, 619–41.
- Hagen, C. (1973). Communication abilities in hemiplegia: effect of speech therapy. *Archives of Physical and Medical Rehabilitation*, 54, 454–63.
- Hager, J.C. and Ekman, P. (1985). The asymmetry of facial actions is inconsistent with models of hemispheric specialization. *Psychophysiology*, 22, 307–18.

- Hagiwara, H., Ito, T., Sugioka, T., Kawamura, M. and Shiota, J. (1999). Neurolinguistic evidence for rule-based nominal suffixation. *Language*, 75, 4, 739–63.
- Haier, R.J., Neuchterlein, K.H., Hazlett, E., Wu, J.C., Pack, J., Browning, H.L. and Buchsbaum, M.S. (1988). Cortical glucose metabolic rate correlates of abstract reasoning and attention studied with positron emission tomography. *Intelligence*, 12, 199–217.
- Haier, R.J., Siegel, B., Tang, C., Abel, L. and Buchsbaum, M.S. (1992). Intelligence and changes in regional cerebral glucose metabolic rate following learning. *Intelligence*, 16, 415–26.
- Hakuta, K. (1986). *Mirror of Language*. New York: Basic Books.
- Hale, A.S. (1997). ABC of mental health: depression. *British Medical Journal*, 315, 43–6.
- Halgren, E. (1992). Emotional neurophysiology of the amygdala within the context of human cognition. In J.P. Aggleton (ed.), *The Amygdala: Neurobiological Aspects of Emotion, Memory and Mental Dysfunction*. New York: Wiley/Liss.
- Hall, D.A. and Riddoch, M.J. (1997). Word meaning deafness: spelling words that are not understood. *Cognitive Neuropsychology*, 14, 1131–64.
- Halligan, P.W. and Cockburn, J.M. (1993). Cognitive sequelae of stroke: visuospatial and memory disorders. *Critical Reviews in Physical and Rehabilitation Medicine*, 5, 1, 57–81.
- Halligan, P.W. and Marshall, J.C. (1991). Left neglect for near but not far space in man. *Nature*, 350, 498–500.
- Halligan, P.W. and Marshall, J.C. (1994). *Spatial Neglect: Position Papers on Theory and Practice*. Hove, UK: Lawrence Erlbaum.
- Halligan, P.W., Marshall, J.C. and Wade, D.T. (1992). Contrapositioning in a case of visual neglect. *Neuropsychological Rehabilitation*, 2, 2, 125–35.
- Halpern, D.F. and Coren, S. (1990). Handedness and life span. *New England Journal of Medicine*, 324, 998.
- Halstead, W.C. (1940). Preliminary analysis of grouping behaviour in patients with cerebral injury by the method of equivalent and non-equivalent stimuli. *American Journal of Psychology*, 96, 1263–94.
- Halstead, W.C. (1947). *Brain and Intelligence: A Quantitative Study of the Frontal Lobes*. Chicago: University of Chicago Press.
- Hanley, J.R. and Davies, A.D.M. (1997). Impaired recall and preserved recognition. In A.J. Parkin (ed.), *Case Studies in the Neuropsychology of Memory*. Hove, UK: Psychology Press.
- Hanlon, H., Thatcher, R. and Cline, M. (1999). Gender differences in the development of EEG coherence in normal children. *Developmental Neuropsychology*, 16, 479–506.
- Hannay, H.J., Varney, N.R. and Benton, A.L. (1976). Visual localization in patients with unilateral brain disease. *Journal of Neurology, Neurosurgery and Psychiatry*, 39, 307–13.
- Hansen, L., Salmon, D.P. and Galasko, D. (1990). The Lewy body variant of Alzheimer's disease: a clinical and pathological entity. *Neurology*, 40, 1–8.
- Happe, F. (1999). Autism: cognitive deficit or cognitive style. *Trends in Cognitive Sciences*, 3, 6, 216–22.
- Happé, F., Brownell, H. and Winner, E. (1999). Acquired 'theory of mind' impairments following stroke. *Cognition*, 70, 211–40.
- Hardyck, C. and Petrinovich, L.F. (1977). Left-handedness. *Psychological Bulletin*, 84, 385–404.
- Hare, R.D. (1984). Performance of psychopaths on cognitive tasks related to frontal lobe function. *Journal of Abnormal Psychology*, 93, 133–40.
- Hare, R.D. (1991). *Manual for the Psychopathy Checklist – Revised*. Toronto: Multi-Health Systems.
- Hare, R.D. (1996). Psychopathy: a clinical construct whose time has come. *Criminal Justice and Behaviour*, 23, 1, 25–54.
- Hariri, A.R., Bookheimer, S.Y. and Mazziotta, J.C. (2000). Modulating emotional responses: effects of a neocortical network on the limbic system. *NeuroReport*, 11, 17, 43–8.
- Harley, T.A. (2004). Does cognitive neuropsychology have a future? *Cognitive Neuropsychology*, 21, 1, 3–16.
- Harlow, J.M. (1848). Passage of an iron rod through the head. *Boston Medicine and Surgery Journal*, 39, 389–93.
- Harlow, J.M. (1868). Recovery from the passage of an iron bar through the head. *Massachusetts Medical Society Publications*, 2, 327–46.
- Harman, D.W. and Ray, W.J. (1977). Hemispheric activity during affective verbal stimuli: an EEG study. *Neuropsychologia*, 15, 157–60.
- Harmon-Jones, E. (2004). On the relationship between frontal brain activity and anger: Examining the role of attitude toward anger. *Cognition and Emotion*, 18, 3, 337–61.
- Harris, I.M., Egan, G.F., Sonkkila, C., Tochon-Danguy, H.J., Paxinos, G. and Watson, J.D.G. (2000). Selective right parietal lobe activation during mental rotation. *Brain*, 123, 65–73.
- Harris, J.E. (1980). We have ways of making you remember. *Concord, The Journal of the British Association for Service to the Elderly*, 17, 21–7.
- Harris, L.J. (1993). Do left-handers die sooner than right-handers? Commentary on Coren and Halpern's (1991) 'Left-handedness: a marker for decreased survival fitness'. *Psychological Bulletin*, 114, 2, 203–34.
- Hartje, W. (1987). The effect of spatial disorders on arithmetical skills. In G. Deloche and X. Seron (eds), *Mathematical Disabilities: A Cognitive Neuropsychological Perspective*. Hillsdale, NJ: Lawrence Erlbaum.

- Harvey, K.V. and Balon, R. (1995). Augmentation with Buspirone: a review. *Annals of Clinical Psychiatry*, 7, 143–7.
- Hatta, T. and Koike, M. (1991). Left-hand preference in frightened mother monkeys in taking up their babies. *Neuropsychologia*, 29, 207–9.
- Haug, H. and Eggers, R. (1991). Morphometry of the human cortex cerebri and corpus callosum during aging. *Neurobiology of Aging*, 12, 336–8.
- Hauser, R.A. *et al.* (1999). Long-term evaluation of bilateral fetal nigral transplantation in Parkinson's disease. *Archives of Neurology*, 56, 179–87.
- Haxby, J.V., Grady, C.L., Koss, E., Horwitz, B., Heston, L., Schapiro, M., Friedland, R.P. and Rapoport, S.I. (1990). Longitudinal study of cerebral metabolic asymmetries and associated neuropsychological patterns in early dementia of the Alzheimer's type. *Archives of Neurology*, 47, 753–60.
- Haxby, J.V., Horwitz, B., Ungerleider, L.G. and Maisog, J.M. (1994). The functional organization of human extrastriate cortex: PET rCBF study of selective attention to faces and locations. *Journal of Neuroscience*, 14, 11, 1, 6336–53.
- Hayward, L., Hall, W., Hunt, M. and Zubrick, S. (1987). Can localized brain impairment be simulated on neuropsychological test profiles? *Australian and New Zealand Journal of Psychiatry*, 21, 1, 87–93.
- Heaton, R.K. (1981). *Wisconsin Card Sorting Test Manual*. Odessa, Fla: Psychological Assessment Resources.
- Hebb, D.O. (1939). Intelligence in man after large removals of cerebral tissue: report of four frontal lobe cases. *Journal of General Psychology*, 21, 73–87.
- Hebb, D.O. (1941). Human intelligence after removal of cerebral tissue from the right frontal lobe. *Journal of General Psychology*, 25, 257–65.
- Hebb, D.O. (1945). Man's frontal lobes: a critical review. *Archives of Neurology and Psychiatry*, 54, 10–24.
- Hebb, D.O. (1949). *Organization of Behaviour*. New York: John Wiley & Sons.
- Hebert, L.E. Scherr, P.A., Beckett, L.A., Albert, M.S., Pilgrim, D.M., Chown, M.J., Funkenstein, H.H. and Evans, D.A. (1995). Age-specific incidence of Alzheimer's disease in a community population. *Journal of the American Medical Association*, 273, 1354–9.
- Hecaen, A. and Ajuriaguerra de J. (1956). Agnosie visuelle pour les objets inanimés par lésion unilatérale gauche. *Revue Neurologique*, 94, 222–3.
- Hecaen, A. and Albert, M.L. (1978). *Human Neuropsychology*. New York: Wiley.
- Hecaen, A. and Angelergues, R. (1962). Agnosia for faces. *Archives of Neurology (Chicago)*, 7, 92–100.
- Hecaen, A. and Angelergues, R. (1963). *La Cécité psychique*. Paris: Masson.
- Hecaen, A., Goldblum, M.C., Massure, M.C. and Ramier, A.M. (1974). Une nouvelle observation d'agnosie d'objet. Déficit de l'association ou de la catégorisation, spécifique de la modalité visuelle. *Neuropsychologia*, 12, 447–64.
- Hecaen, H. (1962). Clinical symptomatology in right and left hemispheric lesions. In V.B. Mountcastle (ed.), *Interhemispheric Relations and Cerebral Dominance*. Baltimore: Johns Hopkins University Press.
- Hecaen, H. (1976). Acquired aphasia in children and the ontogenesis of hemispheric functional specialisation. *Brain and Language*, 3, 114–34.
- Hecaen, H. (1978). Les apraxies ideomotrices: essai de dissociation. In H. Hecaen and M. Jeannerod (eds), *Du Contrôle moteur à l'organisation du geste*. Paris: Masson.
- Hecaen, H. and Rondot, P. (1985). Apraxia as a disorder of signs. In E. Roy (ed.), *Neuropsychological Studies of Apraxia and Related Disorders*. Elsevier: Amsterdam.
- Hecaen, H., Tzortzis, C. and Rondot, P. (1980). Loss of topographic memory with learning deficits. *Cortex*, 16, 525–42.
- Heilman, K.M. (1975). A tapping test in apraxia. *Cortex*, 11, 259–63.
- Heilman, K.M. (1979). Apraxia. In K.M. Heilman and E. Valenstein (eds), *Clinical Neuropsychology*. New York: Oxford University Press.
- Heilman, K.M. and Rothi, L.J.G. (1993). Apraxia. In K.M. Heilman and E. Valenstein (eds), *Clinical Neuropsychology* (3rd edition). New York: Oxford University Press.
- Heilman, K.M. and Rothi, L.J.G. (1997). Limb apraxia: a look back. In L.J.G. Rothi and K.M. Heilman (eds), *Apraxia: The Neuropsychology of Action*. Hove, UK: Psychology Press.
- Heilman, K.M., Rothi, L.J.G. and Valenstein, E. (1982). Two forms of ideomotor apraxia. *Neurology*, 32, 342–6.
- Heilman, K.M. and Valenstein, E. (1979). Mechanisms underlying hemispatial neglect. *Annals of Neurology*, 5, 166–70.
- Heilman, K.M., Valenstein, E. and Watson, R.T. (1994). The what and how of neglect. In P.W. Halligan and J.C. Marshall (eds), *Spatial Neglect: Position Papers on Theory and Practice*. Hove, UK: Lawrence Erlbaum.
- Heilman, K.M., Watson, R.T. and Valenstein, E. (2003). Neglect and related disorders. In K.M. Heilman and E. Valenstein (eds), *Clinical Neuropsychology*. New York: Open University Press.
- Helenius, P., Salmelin, R., Service, E. and Connolly, J. (1999). Semantic cortical activation in dyslexic readers. *Journal of Cognitive Neuroscience*, 11, 535–50.
- Helenius, P., Salmelin, R., Service, E., Connolly, J.F., Leinonen, S. and Lyytinen, H. (2002). Cortical activation during spoken word segmentation in nonreading impaired and dyslexic adults. *Journal of Neuroscience*, 22, 7, 2936–44.

- Helkala, E.L., Laulumaa, V., Soinninen, H. and Riekkinen, P.J. (1988). Recall and recognition memory in patients with Alzheimer's and Parkinson's diseases. *Annals of Neurology*, 24, 214–17.
- Hellige, J.B. (1991). Cerebral laterality and metacontrol. In F. Kitterle (ed.), *Recent Advances in Laterality*. Hillsdale, NJ: Lawrence Erlbaum.
- Hellige, J.B. and Michimata, C. (1989). Visual laterality for letter comparison: effects of stimulus factors, response factors and metacontrol. *Bulletin of the Psychonomic Society*, 27, 441–4.
- Hellige, J.B., Taylor, A.K. and Eng, T.L. (1989). Interhemispheric interaction when both hemispheres have access to the same stimulus information. *Journal of Experimental Psychology: Human Perception and Performance*, 15, 711–22.
- Henriques, J.B. and Davidson, R.J. (1991). Left frontal hypoactivation in depression. *Journal of Abnormal Psychology*, 100, 535–45.
- Henry, T.R., Bakay, R.A.E. and Votaw, J.R. (1998). Brain blood flow alterations induced by therapeutic vagus nerve stimulation in partial epilepsy: I. Acute effects at high and low levels of stimulation. *Epilepsia*, 39, 983–90.
- Herbster, A.N., Mintun, M.A., Nebes, R.D. and Becker, J.T. (1997). Regional cerebral blood flow during word and nonword reading. *Human Brain Mapping*, 5, 84–92.
- Hermann, B.P., Wyler, A.R., Richey, E.T. and Rea, J.M. (1987). Memory function and verbal learning in patients with complex partial seizures of temporal origin. *Epilepsia*, 28, 547–54.
- Hermann, H.T. and Zeevi, Y.Y. (1991) Interhemispheric interactions and dyslexia. In J.F. Stein (ed.), *Vision and Visual Dyslexia*. London: Macmillan.
- Hertz-Pannier, L., Chiron, C., Jambaque, I., Renaux-Kieffer, V., Van de Moortele, P.-F., Delalande, O., Fohlen, M., Brunelle, F. and Le Bihan, D. (2002). Late plasticity for language in a child's non-dominant hemisphere. *Brain*, 125, 361–372.
- Heschl, R.L. (1878). *Die vordere quere Schlingenwindung des menschlichen Grosshirns*. Vienna: Wilhelm Braumüller.
- Hickok, G., Love-Gefen, T. and Klima, E. (2002). Role of the left hemisphere in sign language comprehension. *Brain and Language*, 82, 167–78.
- Hicks, R.A. and Beveridge, R. (1978). Handedness and intelligence. *Cortex*, 14, 304–7.
- Highley, J.R., McDonald, B., Walker, M.A., Esiri, M.M. and Crow, T.J. (1999). Schizophrenia and temporal lobe asymmetry. *British Journal of Psychology*, 175, 127–34.
- Hillis, A.E., Kane, A., Tuffiash, E., Ulatowski, J.A. and Barker, P.B. (2001). Reperfusion of specific brain regions by raising blood pressure restores selective language functions in subacute stroke. *Brain and Language*, 79, 495–510.
- Hirayasu, Y., Shenton, M.E., Salisbury, D.F., Kwon, J.S., Wible, C.G., Foster, I.A., Yurgelun-Dodd, D., Kikinis, R., Jolesz F.A., and McCorley R.W. (1999). Subgenual cingulate cortex volume in first-episode psychosis. *American Journal of Psychiatry*, 156, 1091–3.
- Hirschfield R.M. (2001). Clinical importance of long-term antidepressant treatment. *British Journal of Psychiatry*, 179(suppl 42), s4–s8.
- Hiscock, M., Inch, R., Jacek, C., Hiscock-Kalil, C. and Kalil, K.M. (1994). Is there a sex difference in human laterality? I. An exhaustive survey of auditory laterality studies from six neuropsychology journals. *Journal of Clinical and Experimental Neuropsychology*, 16, 3, 423–35.
- Hiscock, M. and Kinsbourne, M. (1995). Phylogeny and ontogeny of cerebral lateralization. In R.J. Davidson and K. Hugdahl (eds), *Brain Asymmetry*. Cambridge, Mass.: MIT Press.
- Ho, M.R. and Bennett, T.L. (1997). *Archives of Clinical Neuropsychology*, 12, 1, 1–11.
- Hodges, J.R., Patterson, K., Ward, R., Garrard, P., Bak, T., Perry, R. and Gregory, C. (1999). The differentiation of semantic dementia and frontal lobe dementia (temporal and frontal variants of frontotemporal dementia) from early Alzheimer's disease: a comparative neuropsychological study. *Neuropsychology*, 13, 13–40.
- Hoeft, H.J. (1957) Klinisch-anatomischer Beitrag zur Kenntnis der Nachsprechaphasie. *Deutsch. Z. Nervenheilk.*, 175, 560–94.
- Hof, R.R. and Morrison, J.H. (2004). The aging brain: morphomolecular senescence of cortical circuits. *Trends in Neurosciences*, 27, 10, 606–13.
- Hoffman, J.J., Hall, R.W. and Bartsch, T.W. (1987). On the relative importance of 'psychopathic' personality and alcoholism on neuropsychological measures of frontal lobe dysfunction. *Journal of Abnormal Psychology*, 96, 158–60.
- Hoffman, R.E., Boutros, N.N., Berman, R.M., Roessler, E., Belger, A., Krystal, J.H. and Charney, D.S. (1999). Transcranial magnetic stimulation of left temporoparietal cortex in three patients reporting hallucinated 'voices'. *Biological Psychiatry*, 46, 130–2.
- Hoffman, R.E., Boutros, N.N., Hu, S., Berman, R.M., Krystal, J.H. and Charney, D.S. (2000). Transcranial magnetic stimulation and auditory hallucinations in schizophrenia. *The Lancet*, 255, 1073–5.
- Hoflich, C., Kasper, S., Hufnagel, A., Ruhrmann, S. and Moller, H.J. (1993). Application of transcranial magnetic stimulation in treatment of drug-resistant major depression – a report of two cases. *Human Psychopharmacology*, 8, 361–5.
- Holland, A. (1980). *Communicative Abilities in Daily Living*, Baltimore: University Park Press.

- Holland, C.A. and Rabbitt, P. (1991). The course and causes of cognitive change with advancing age. *Reviews in Clinical Gerontology*, 1, 81–96.
- Holland, S.K., Plante, E., Weber Byars, A., Strawsburg, R.H., Schmithorst, V.J. and Ball, W.S. (2001). Normal fMRI brain activation patterns in children performing a verb generation task. *Neuroimage*, 14, 837–43.
- Holligan, C. and Johnston, R.S. (1988). The use of phonological information by good and poor readers in memory and reading tasks. *Memory and Cognition*, 16, 6, 522–32.
- Holloway, R.L. (1966). Dendritic branching: some preliminary results of training and complexity in rat visual cortex. *Brain Research*, 2, 393–6.
- Holloway, R.L. and Lacoste, M.-C. de (1986). Sexual dimorphism in the human corpus callosum: an extension and replication study. *Human Neurobiology*, 5, 87–91.
- Holmes, G. (1918). Disturbances of visual orientation. *British Journal of Ophthalmology*, 2, 449–68.
- Holmes, G. (1931). Discussion on the mental symptoms associated with cerebral tumors. *Proceedings of the Royal Society of Medicine*, 24, 997–1000.
- Holmes-Bernstein, J. (1999). Developmental neuropsychological assessment. In K.O. Yates, M.D. Ris and H.G. Taylor (eds), *Pediatric Neuropsychology: Research, Theory and Practice*. New York: Guilford Press.
- Hoptman, M.J. and Davidson, R.J. (1994). How and why do the two cerebral hemispheres interact? *Psychological Bulletin*, 116, 2, 195–219.
- Horn, J.L. and Cattell, R.B. (1967). Age differences in fluid and crystallized intelligence. *Acta Psychologica*, 26, 107–29.
- Hornak, J., Rolls, E.T. and Wade, D. (1996). Face and voice expression identification in patients with emotional and behavioural changes following ventral frontal lobe damage. *Neuropsychologia*, 34, 4, 247–61.
- Horvath, T.B. and Davis, K.L. (1990). Central nervous system disorders in aging. In E.L. Schneider and J.W. Rowe (eds), *Handbook of the Biology of Aging* (3rd edition). San Diego: Academic Press.
- Horwitz, B., Rumsey, J.M. and Donohue, B.C. (1998). Functional connectivity of the angular gyrus in normal reading and dyslexia. *Proceedings of the National Academy of Sciences of the United States of America*, 95, 8939–44.
- Hounsfield, G.N. (1973). Computerized transverse axial scanning (tomography). Part I: description of the system. *British Journal of Radiology*, 46, 1016–22.
- Hubel, D.H. and Wiesel, T.N. (1979). Brain mechanisms of vision. *Scientific American*, 241, 150–62.
- Huber, W., Poeck, K. and Springer, L. (1991). *Sprachstörungen*. Stuttgart: TRIAS.
- Hublely, A.M. and Tremblay, D. (2002). Comparability of total score performance on the Rey–Osterrieth Complex Figure and a modified Taylor Complex Figure. *Journal of Clinical and Experimental Neuropsychology*, 24, 370–82.
- Hudspeth, W. and Pribram, K. (1990). Stages of brain and cognitive maturation. *Journal of Educational Psychology*, 82, 881–4.
- Hughlings-Jackson, J. (1870) On voluntary and automatic movements. *British Medical Journal*, 2, 641–2.
- Hulme, C. (1988). Short-term memory development and learning to read. In M. Gruneberg, P. Morris and R. Sykes (eds), *Practical Aspects of Memory: Current Research and Issues*, Vol. 2, *Clinical and Educational Implications*. Chichester, UK: John Wiley & Sons.
- Hulme, C. and Roodenrys, S. (1995). Practitioner review: verbal working memory development and its disorders. *Journal of Child Psychology and Psychiatry*, 36, 3, 373–98.
- Humphreys, G.W. and Riddoch, M.J. (1987a). *To See or not to See: A Case Study of Visual Object Processing*. Hove, UK: Lawrence Erlbaum.
- Humphreys, G.W. and Riddoch, M.J. (1987b). The fractionation of visual agnosia. In G.W. Humphreys and M.J. Riddoch (eds), *Visual Object: A Cognitive Neuropsychological Approach*. London: Lawrence Erlbaum.
- Humphreys, G.W. and Riddoch, M.J. (1993). Object agnosias. *Ballière's Clinical Neurology*, 2, 339–59.
- Humphreys, G.W. and Riddoch, M.J. (2001). Detection by action: neuropsychological evidence for action-defined templates in search. *Nature Neuroscience*, 4, 1, 84–8.
- Huttenlocher, P.R. and Dabholkar, A. (1997). Developmental anatomy of prefrontal cortex. In N. Krasnegor, G. Lyon and P.S. Goldman-Rakic (eds), *Development of the Prefrontal Cortex*. Baltimore: Brookes.
- Indefrey, P., Brown, C.M., Hellwig, F., Amunts, K. and Herzog, H. (2001). A neural correlate of syntactic encoding during speech production. *Proceedings of the National Academy of Sciences*, 98, 5933–6.
- Indefrey, P. and Levelt, W. (2000). A neural correlate of syntactic encoding during speech production. In M. Gazzaniga (ed.), *The New Cognitive Neurosciences*. Cambridge, Mass.: MIT Press.
- Insua, A.M. (1983). WAIS-R factor structures in two cultures. *Journal of Cross-Cultural Psychology*, 14, 4, 427–38.
- Irle, E. and Markowitsch, H.J. (1982). Thiamine deficiency in the cat leads to severe learning deficits and to widespread neuroanatomical damage. *Experimental Brain Research*, 48, 199–208.
- Isaac, C.L. and Mayes, A.R. (1999). Rate of forgetting in amnesia II: recall and recognition of word lists at different levels of organisation. *Journal of Experimental Psychology: Learning, Memory and Cognition*, 25, 963–77.

- Isaacs, E.B., Edmonds, C.J., Lucas, A. and Gadian, D.G. (2001). Calculation difficulties in children of very low birthweight: a neural correlate. *Brain*, 124, 1701–7.
- Ishai, S., Furukawa, T. and Tsukagoshi, H. (1989). Visuospatial processes of line bisection and the mechanisms underlying unilateral spatial neglect. *Brain*, 112, 1485–502.
- Ischebeck, A., Indefrey, P., Usui, N., Nose, I., Hellwig, F. and Taira, M. (2004). Reading in a regular orthography: an fMRI study investigating the role of visual familiarity. *Journal of Cognitive Neuroscience*, 16, 5, 727–41.
- Ishikawa, A. and Miyatake, T. (1993). Effects of smoking in patients with early-onset Parkinson's disease. *Journal of Neurological Science*, 117, 28–32.
- Ishikawa, S.S., Raine, A., Lencz, T., Bihrl, S. and Lacasse, L. (2001). Autonomic stress reactivity and executive functions in successful and unsuccessful criminal psychopaths from the community. *Journal of Abnormal Psychology*, 110, 3, 423–32.
- Iversen, S.D. and Mishkin, M. (1970). Perseverative interference in monkey following selective lesions of the inferior prefrontal convexity. *Experimental Brain Research*, 11, 376–86.
- Ivnik, R.J., Sharbrough, F.W. and Laws, E.R. (1987). Effects of anterior temporal lobectomy on cognitive function. *Journal of Clinical Psychology*, 43, 128–37.
- Jablensky, A. (1989). Epidemiology and cross-cultural aspects of schizophrenia. *Psychiatric Annals*, 19, 516–24.
- Jablensky, A., Sartorius, N., Ernberg, G., Anker, M., Korten, A., Cooper, J.E., Day, R. and Bertelsen, A. (1992). Schizophrenia: manifestations, incidence and course in different cultures. A WHO ten country study. *Psychological Medicine Monograph Supplement 20*. Cambridge: Cambridge University Press.
- Jacobs, B. *et al.* (1997). Life-span dendritic and spine changes in areas 10 and 18 of human cortex: a quantitative Golgi study. *Journal of Comparative Neurology*, 386, 661–80.
- Jacobson, R. (1986). Disorders of facial recognition, social behaviour and affect after combined bilateral amygdalotomy and subcaudate tractotomy: a clinical and experimental study. *Psychological Medicine*, 16, 439–50.
- Jacobson, R.R. and Lishman, W. (1990). Cortical and diencephalic lesions in Korsakoff's syndrome: a clinical and CT scan study. *Psychological Medicine*, 20, 63–75.
- Jahanshahi, M. and Rothwell, J. (2000). Transcranial magnetic stimulation studies of cognition: an emerging field. *Experimental Brain Research*, 13, 1–9.
- Jakobson, L.S., Archibald, Y.M., Carey, D.P. and Goodale, M.A. (1991). A kinematic analysis of reaching and grasping movements in a patient recovering from optic ataxia. *Neuropsychologia*, 29, 803–9.
- James, W. (1884). What is emotion? *Mind*, 19, 188–205.
- James, W. (1890). *The Principles of Psychology*. New York: Henry Holt.
- James, T. and Dalton, R. (1993). Modification of the WAIS-R information sub-test for use with an Irish population. *Irish Journal of Psychology*, 14, 4, 589–95.
- Janowic, J. (1993). Tourette's syndrome: phenomenology, pathophysiology, genetics, epidemiology and treatment. In S.H. Appel (ed.), *Current Neurology*, Vol. 13. Chicago: Mosby Yearbook.
- Janowsky, D.S., El-Yousef, M.K., Davis, J.M., Hubbard, B. and Sekerke, H.J. (1972). Cholinergic reversal of manic symptoms. *The Lancet*, 1, 1236–7.
- Janowsky, J.S., Shimamura, A.P., Kritchevsky, M. and Squire, L.R. (1989). Cognitive impairment following frontal lobe damage and its relevance to human amnesia. *Behavioural Neuroscience*, 103, 548–60.
- Jausovec, N. (1996). Differences in EEG alpha activity related to giftedness. *Intelligence*, 23, 159–73.
- Jausovec, N. (1998). Are gifted individuals less chaotic thinkers? *Personality and Individual Differences*, 25, 253–67.
- Jeannerod, M. (1986). Mechanisms of visuomotor coordination: a study in normal and brain-damaged subjects. *Neuropsychologia*, 24, 41–78.
- Jeannerod, M. (1997). *The Cognitive Neuroscience of Action*. Oxford: Basil Blackwell.
- Jeannerod, M., Decety, J. and Michel, F. (1994). Impairment of grasping movements following a bilateral posterior parietal lesion. *Neuropsychologia*, 32, 369–80.
- Jenicke, M.A., Breiter, H.C., and Baer, L. (1996). Cerebral structural abnormalities in obsessive-compulsive disorder. A quantitative morphometric magnetic resonance imaging study. *Archives of General Psychiatry*, 53, 625–32.
- Jobard, G., Crivello, F. and Tzourio-Mazoyer, N. (2003). Evaluation of the dual route theory of reading: a meta-analysis of 35 neuroimaging studies. *Neuroimage*, 20, 693–712.
- Johnson, D.J. and Blalock, J.W. (1987). *Adults with Learning Disabilities*. Orlando, Fla: Grune and Stratton.
- Johnson, D.J. and Grant, J.O. (1989). Written narratives of normal and learning-disabled children. *Annals of Dyslexia*, 39, 140–58.
- Johnson, M.K., Hashtroudi, S. and Lindsay, D.S. (1993). Source monitoring. *Psychological Bulletin*, 114, 3–28.
- Johnstone, J., Galin, D., Fein, G., Yingling, C., Herron, J. and Marcus, M. (1984). Regional brain activity in dyslexic and control children during reading tasks: visual probe event-related potentials. *Brain and Language*, 21, 233–54.

- Jones-Gotman, M. and Milner, B. (1977). Design fluency: the invention of nonsense drawings after focal cortical lesions. *Neuropsychologia*, 15, 653–74.
- Jones-Gotman, M. and Zatorre, R.J. (1993). Odor recognition memory in humans: role of right temporal and orbitofrontal regions. *Brain and Cognition*, 22, 182–98.
- Jonsson, B. and Bebbington, P.E. (1994). What price depression? The cost of depression and the cost-effectiveness of pharmacological treatment. *British Journal of Psychiatry*, 172, 35–7.
- Jordan, T.R., Patching, G.R. and Milner, A.D. (1998). Central fixations are inadequately controlled by instructions alone: implications for studying cerebral asymmetry. *Quarterly Journal of Experimental Psychology*, 51A, 2, 371–91.
- Jorm, A. (1990). *The Epidemiology of Alzheimer's Disease and Related Disorders*. London: Chapman and Hall.
- Julien, R.M. (2004). *A Primer of Drug Action*. 10th edition. New York: Worth.
- Jung, R. (1974). Neuropsychologie und neurophysiologie des konturund formsehens in zeichneri und malerei. In H. Weick (ed.), *Psychopathologie Musischer Gestaltungen*, Stuttgart: FK Schattauer.
- Justus, T. (2004). The cerebellum and English grammatical morphology: evidence from production, comprehension, and grammaticality judgements. *Journal of Cognitive Neuroscience*, 16, 7, 1115–30.
- Justus, T. and Ivry, R.B. (2001). The cognitive neuropsychology of the cerebellum. *International Review of Psychiatry*, 13, 276–82.
- Kaczmarek, B.L.J. (1991). Aphasia in an artist: a disorder of symbolic processing. *Aphasiology*, 5, 361–71.
- Kaczmarek, B.L.J., Code, C. and Wallesch, C.-W. (2002). The fractionation of mental life: Luria's study of Lieutenant Zasetzky. In C. Code, C.-W. Wallesch, Y. Joannette and A.R. Lecours (eds), *Classic Cases in neuropsychology*, Vol. 2. Hove, UK: Psychology Press.
- Kandel, E. (1991). Brain and behaviour. In E. Kandel, J.H. Schwartz and T.M. Jessell (eds), *Principles of Neural Science*. New York: Elsevier.
- Kandel, E., Schwartz, J.H. and Jessell, T.M. (1995) *Essentials of Neural Science and Behaviour*, International edition. UK: McGraw-Hill.
- Kane, M.J., Hambrick, D.Z. and Conway, A.R.A. (2005). Working memory capacity and fluid intelligence are strongly related constructs: comment on Ackerman, Beier and Boyle (2005). *Psychological Bulletin*, 131, 1, 66–71.
- Kanwisher, N., Stanley, D. and Harris, A. (1999). The fusiform face area is selective for faces not animals. *NeuroReport*, 10, 183–87.
- Kanwisher, N., Tong, F. and Nakayama, K. (1998). The effect of face inversion on the human fusiform face area. *Cognition*, 68, B1–B11.
- Kaplan, E., Fein, D., Morris, R. and Delis, D. (1991). *WAIS-R as a neuropsychological instrument*. San Antonio: Psychological Corporation.
- Kaplan, E., Goodglass, H. and Weintraub, S. (1983). *Boston Naming Test*. Philadelphia: Lea and Febiger.
- Kapur, N. (1993). Focal retrograde amnesia in neurological disease: a critical review. *Cortex*, 29, 217–34.
- Kapur, N. (1997). Autobiographical amnesia and temporal lobe pathology. In A.J. Parkin (ed.), *Case Studies in the Neuropsychology of Memory*. Hove, UK: Psychology Press.
- Kapur, N. and Butters, N. (1977). Visuo-perceptive deficits in long-term alcoholics with Korsakoff's psychosis. *Journal of Studies on Alcohol*, 40, 791–6.
- Kapur, N., Thompson, S., Cook, P., Lang, D. and Brice, J. (1996). Anterograde but not retrograde memory loss following combined mammillary body and medial thalamic lesions. *Neuropsychologia*, 34, 1, 1–8.
- Karayorgou, M., Morris, M.A. and Morrow, B. (1995). Schizophrenia susceptibility associated with interstitial deletions of chromosome 22q11. *Proceedings of the National Academy of Sciences, USA*, 92, 7612–16.
- Karnath, H.O. (1994). Disturbed coordinate transformation in the neural representation of space as the crucial mechanism leading to neglect. In P.W. Halligan and J.C. Marshall (eds), *Spatial Neglect: Position Papers on Theory and Practice*. Hove, UK: Lawrence Erlbaum.
- Karnath, H.O., Berger, M.F., Kuker, W. and Rorden, C. (2004). The anatomy of spatial neglect based on voxel-wise statistical analysis: a study of 140 patients. *Cerebral Cortex*, 14, 10, 1164–72.
- Karnath, H.O., Christ, K. and Hartje, W. (1993). Decrease of contralateral neglect by neck muscle vibration and spatial orientation of trunk midline. *Brain*, 116, 383–96.
- Kaski, D. (2002). Revision: is visual perception a requisite for visual imagery? *Perception*, 31, 717–31.
- Katz, R.B., Shankweiler, D. and Liberman, I.Y. (1981). Memory for item order and phonetic recoding in the beginning reader. *Journal of Experimental Child Psychology*, 32, 474–84.
- Kaufmann, W.E. and Galaburda, A.M. (1989) Cerebrocortical microdysgenesis in neurologically normal subjects – a histopathologic study. *Neurology*, 39, 2, 238–44.
- Kaye, W.H., Sitaram, N., Weingartner, H., Elbert, M.H., Smallberg, G. and Gillin, J.C. (1982). Modest facilitation of memory in dementia with combined lecithin and anticholinesterase treatment. *Biological Psychiatry*, 17, 275–80.
- Keefe, R.S.E., Roitman, S.E.C. and Harvey, P.D. (1995). A pen-and-paper human analogue of a monkey prefrontal cortex activation task: spatial working memory in patients with schizophrenia. *Schizophrenia Research*, 17, 25–33.

- Keenan, S.S. and Brassel, E.G. (1974). A study of factors related to prognosis for individual aphasic patients. *Journal of Speech and Hearing Disorders*, 39, 257–69.
- Kempermann, G. and Gage, F.H. (1999). New nerve cells for the adult brain. *Scientific American*, May, 48–53.
- Kempermann, G., Kuhn, G. and Gage, F.H. (1997). More hippocampal neurons in adult mice living in an enriched environment. *Nature*, 386, 493–5.
- Kendell, R.E. (1981). The present status of electroconvulsive therapy. *British Journal of Psychiatry*, 139, 265–83.
- Kenin, M. and Swisher, L. (1972). A study of pattern of recovery in aphasia. *Cortex*, 8, 56–68.
- Kennard, M.A. (1936). Age and other factors in motor recovery from precentral lesions in monkeys. *American Journal of Physiology*, 115, 138–46.
- Kennard, M.A. (1940). Relation of age to motor impairment in man and subhuman primates. *Archives of Neurology and Psychiatry*, 44, 377–97.
- Kennard, M.A. (1942). Cortical reorganisation of motor function: studies on series of monkeys of various ages from infancy to maturity. *Archives of Neurology and Psychiatry*, 48, 227–40.
- Kennedy, H., Meissner, C. and Dehay, C. (1991). Callosal pathways and their compliancy to general rules governing the organization of corticocortical connectivity. In B. Dreher and S.R. Robinson (eds), *Neuroanatomy of the Visual Pathways and their Development*. Boca Raton, Fla: Chemical Rubber Company.
- Kertesz, A. (1979). *Aphasia and Associated Disorders*. New York: Grune and Stratton.
- Kertesz, A. (1981). Anatomy of jargon. In J. Brown (ed.), *Jargonaphasia*. New York: Academic Press.
- Kertesz, A. (1987). Recovery of language disorders. In S. Finger, T.E. LeVere, C.R. Almlie and D.G. Stein (eds), *Brain Injury and Recovery: Theoretical and Controversial Issues*. New York: Plenum.
- Kertesz, A. (1988). What do we learn from aphasia? In S.G. Waxman (ed.), *Advances in Neurology*, Vol. 47, *Functional Recovery in Neurological Disease*. New York: Raven Press.
- Kertesz, A. (1993). Recovery and treatment. In K.M. Heilman and E. Valenstein (eds), *Clinical Neuropsychology* (3rd edition). New York: Oxford University Press.
- Kertesz, A. (1995). Recovery in aphasia and language networks. *Neurorehabilitation*, 5, 2, 103–13.
- Kertesz, A., Dennis, S., Polk, M. and McCabe, P. (1989). The structural determinants of recovery in Wernicke's aphasia. *Neurology*, 39, suppl. 1, 177.
- Kertesz, A. and McCabe, P. (1977). Recovery patterns and prognosis in aphasia. *Brain*, 100, 1–18.
- Kertesz, A. and Munoz, D. (1998). Pick's disease, frontotemporal dementia, and Pick complex: emerging concepts. *Archives of Neurology*, 55, 302–4.
- Kertesz, A. and Poole, E. (1974). The aphasia quotient: the taxonomic approach to measurement of aphasic disability. *Canadian Journal of Neurological Science*, 1, 7–16.
- Kertesz, A., Sheppard, A. and Mackenzie, R. (1982). Localisation in transcortical sensory aphasia. *Archives of Neurology*, 39, 475.
- Kessels, R.P.C., de Haan, E.H.F., Kappelle, L.J. and Postma, A. (2001). Varieties of human spatial memory: a meta-analysis on the effects of hippocampal lesions. *Brain Research Reviews*, 35, 295–303.
- Kestler, L.P., Walker, E. and Vega, E.M. (2001). Dopamine receptors in the brains of schizophrenia patients: a meta-analysis of the findings. *Behavioural Pharmacology*, 12, 5, 355–71.
- Kim, H.J., Burke, D.T., Dowds, M.M., Robinson Boone, K.A. and Park, G.J. (2000). Electronic memory aids for outpatient brain injury: follow-up findings. *Brain Injury*, 14, 2, 187–96.
- Kim, K., Kim, J., Ku, J., Kim, D.Y., Chang, W.H., Shin, D.I., Lee, J.H., Kim, I.Y. and Kim, S.I. (2004). A virtual reality assessment and training system for unilateral neglect. *Cyberpsychology and Behavior*, 7, 6, 742–9.
- Kim, K., Relkin, N., Lee, K. and Hirsch, J. (1997). Distinct cortical areas associated with native and second languages. *Nature*, 171–4.
- Kim, M. and Davis, M. (1993). Lack of temporal gradient of retrograde amnesia in rats with amygdala lesions assessed with the fear-potentiated startle paradigm. *Behavioural Neuroscience*, 107, 1088–92.
- Kimbrell, T.A., Little, J.T., Dunn, R.T., Frye, M.A., Greenberg, B.D., Wassermann, E.M., Repella, J.D., Danielson, A.L., Willis, M.W., Benson, B.E., Speer, A.M., Osuch, E., George, M.S. and Post, R.M. (1999). Frequency dependence of antidepressant response to left prefrontal repetitive transcranial magnetic stimulation (rTMS) as a function of baseline cerebral glucose metabolism. *Biological Psychiatry*, 46, 1603–13.
- Kime, S.K., Lamb, D.G. and Wilson, B.A. (1996). Use of a comprehensive programme of external cueing to enhance procedural memory in a patient with dense amnesia. *Brain Injury*, 10, 1, 17–25.
- Kimura, D. (1961). Some effects of temporal lobe damage on auditory perception. *Canadian Journal of Psychology*, 15, 156–65.
- Kimura, D. (1963). Right temporal lobe damage: perception of unfamiliar stimuli after damage. *Archives of Neurology*, 8, 264–71.
- Kimura, D. (1964). Left–right differences in the perception of melodies. *Quarterly Journal of Experimental Psychology*, 16, 355–8.

- Kimura, D. (1969). Spatial localization in left and right visual fields. *Canadian Journal of Psychology*, 23, 445–58.
- Kimura, D. (1982). Left hemisphere control of oral and brachial movements and their relationship to communication. *Philosophical Transactions of the Royal Society of London, Series B*, 298, 135–49.
- Kimura, D. (1999). *Sex and Cognition*. MIT Press.
- Kimura, D. (2004). Human sex differences in cognition, fact, not predicament. *Sexualities, Evolution and Gender*, 6, 45–53.
- Kindermann, S.S., Karimi, A., Symonds, L., Brown, G.G. and Jeste, D.V. (1997). Review of functional magnetic resonance imaging in schizophrenia. *Schizophrenia Research*, 27, 2–3, 143–56.
- Kinsbourne, M. (1987). Mechanisms of unilateral neglect. In M. Jeannerod (ed.), *Neurophysiological and Neuropsychological Aspects of Spatial Neglect*. Amsterdam: North-Holland.
- Kinsbourne, M. (1998). Unity and diversity in the human brain: evidence from injury. *Daedalus*, 127, 2, 233–56.
- Kinsella, G. and Ford, B. (1985). Hemi-inattention and the recovery patterns of stroke patients. *International Rehabilitation Medicine*, 7, 102.
- Kish, S.J., Shannak, K. and Hornykiewicz, O. (1988). Uneven pattern of dopamine loss in the striatum of patients with idiopathic Parkinson's disease: pathophysiologic and clinical implications. *New England Journal of Medicine*, 318, 876–81.
- Klein, D., Milner, B., Zatorre, R.J. Meyer, E. and Evans, A. (1995). The neural substrates underlying word generation: A bilingual functional imaging study. *Proceedings of the National Academy of Sciences, USA*, 92, 2899–903.
- Klein, D., Milner, B., Zatorre, R.J., Zhao, V. and Nikelski, J. (1999). Cerebral organization in bilinguals: a PET study of Chinese–English verb generation. *NeuroReport*, 10, 2841–6.
- Kleist, K. (1934). *Gehirnpathologie*. Leipzig: Barth.
- Kliegel, M., McDaniel, M.A. and Einstein, G.O. (2000). Plan formation, retention, and execution in prospective memory: A new approach and age-related effects. *Memory and Cognition*, 28, 6, 1041–9.
- Klimesch, W., Doppelmayr, M., Schimke, H. and Ripper, B. (1997). Theta synchronization and alpha desynchronization in a memory task. *Psychophysiology*, 34, 169–76.
- Klinberg, T., Viadya, C., Gabrieli, J., Moseley, M. and Hedehus, M. (1999). Myelination and organisation of the frontal white matter in children: a diffusion tensor MRI study. *NeuroReport*, 10, 2817–21.
- Kluver, H. and Bucy, P.C. (1939). Preliminary analysis of functions of the temporal lobes in monkeys. *Archives of Neurology and Psychiatry*, 42, 979–1000.
- Knaus, T.A., Bollich, A.M., Corey, D.M., Lemen, L.C. and Foundas, A.L. (2004). Sex-linked differences in the anatomy of the perisylvian language cortex: a volumetric MRI study of gray matter volumes. *Neuropsychology*, 18, 4, 738–47.
- Knecht, S., Deppe, E., Drager, B., Bobe, L., Lohmann, H., Ringelstein, E.-B. and Henningsen, H. (2000). Language lateralization in healthy right-handers. *Brain*, 123, 74–81.
- Knecht, S., Drager, B., Deppe, M., Bobe, L., Lohmann, H., Floel, A., Ringelstein, E.-B. and Henningsen, H. (2000). Handedness and hemispheric language dominance in healthy humans. *Brain*, 123, 2512–18.
- Knight, C., Alderman, N. and Burgess, P.W. (2002). Development of a simplified version of the multiple errands test for use in hospital settings. *Neuropsychological Rehabilitation*, 12, 3, 231–55.
- Knight, D.C., Cheng, D.T., Smith, C.N., Stein, E.A. and Helmstetter, F.J. (2004). Neural substrates mediating human delay and trace fear conditioning. *Journal of Neuroscience*, 24, 1, 218–28.
- Knight, D.C., Smith, C.N., Stein, E.A. and Helmstetter, F.J. (1999). Functional MRI of human Pavlovian fear conditioning: patterns of activation as a function of learning. *NeuroReport*, 10, 3665–70.
- Kohn, B. and Dennis, M. (1974). Selective impairments of visuo-spatial abilities in infantile hemiplegics after right hemidecortication. *Neuropsychologia*, 12, 505–12.
- Kolb, B. and Milner, B. (1981). Performance of complex arm and facial movements after focal brain lesions. *Neuropsychologia*, 19, 505–14.
- Kolb, B. and Wishaw, I.Q. (1987). Mass action and equipotentiality reconsidered. In S. Finger, T.E. LeVere, C.R. Almlie and D.G. Stein (eds), *Brain Injury and Recovery: Theoretical and Controversial Issues*. New York: Plenum.
- Kolb, B. and Wishaw, I.Q. (1989). Plasticity in the neocortex: mechanisms underlying recovery from early brain damage. *Progress in Neurobiology*, 32, 235–76.
- Kolodny, A. (1929). Symptomatology of tumor of the frontal lobe. *Archives of Neurology and Psychiatry*, 21, 1107–27.
- Kopelman, M.D. (1991). Non-verbal, short-term forgetting in the alcoholic Korsakoff syndrome and Alzheimer-type dementia. *Brain*, 114, 117–37.
- Kopelman, M.D. (1995). The Korsakoff syndrome. *British Journal of Psychiatry*, 166, 154–73.
- Korsakoff, S.S. (1889a). Psychic disorder in conjunction with peripheral neuritis. *Neurology*, 5, 394–406.
- Korsakoff, S.S. (1889b). Etude medico-psychologique sur une forme des maladies de la memoire. *Revue Philosophie*, 20, 501–30.
- Kosslyn, S.M. (1987). Seeing and imagining in the cerebral hemispheres: a computational approach. *Psychological Review*, 94, 148–75.

- Kosslyn, S.M., DiGirolamo, G.J., Thompson, W.L. and Alpert, N.M. (1998). Mental rotation of objects vs hands: neural mechanisms revealed by positron emission tomography. *Psychophysiology*, 35, 2, 151–61.
- Kosslyn, S.M. and Intriligator, J.M. (1992). Is cognitive neuropsychology plausible? The perils of sitting on a one-legged stool. *Journal of Cognitive Neuroscience*, 4, 1, 96–106.
- Kosslyn, S.M. and Van Kleeck, M.H. (1990). Broken brains and normal minds: why Humpty Dumpty needs a skeleton. In E.L. Schwartz (ed.), *Computational Neuroscience*. Cambridge, Mass.: MIT Press.
- Krashen, S.D. (1973). Lateralization, language learning and the critical period: some new evidence. *Language Learning*, 23, 63–74.
- Kratskin, I.L. (1995). Functional anatomy, central connections, and neurochemistry of the mammalian olfactory bulb. In R.L. Doty (ed.), *Handbook of Olfaction and Gustation*. New York: Marcel Dekker.
- Kratz, K.E., Spear, P.D. and Smith, D.C. (1976). Postcritical-period reversal of effects of monocular deprivation on striate cells in the cat. *Journal of Neurophysiology*, 39, 501–11.
- Krauss, G.L., Summerfield, M., Brandt, J., Breiter, S. and Ruchkin, D. (1997). Mesial temporal lobe spikes interfere with working memory. *Neurology*, 49, 975–80.
- Kreiman, G., Koch, C. and Fried, I. (2000a). Imagery neurons in the human brain. *Nature*, 408, 357–61.
- Kreiman, G., Koch, C. and Fried, I. (2000b). Category-specific visual responses of single neurons in the human medial temporal lobe. *Nature Neuroscience*, 3, 9, 946–53.
- Kreindler, A. and Fradis, A. (1968). *Performances in Aphasia: A Neurodynamical, Diagnostic and Psychological Study*. Paris: Gauthier-Villars.
- Kreutzberg, G.W. (1996). Microglia: a sensor for pathological events in the CNS. *Trends in Neuroscience*, 19, 8, 312–18.
- Krieger, S., Lis, S. and Gallhofer, B. (2001). Cognitive subprocesses and schizophrenia: a reaction-time decomposition. *Acta Psychiatrica Scandinavica*, 104, 408, 18–27.
- Kringelbach, M.L., O'Doherty, J., Rolls, E.T. and Andrews, C. (2003). Activation of the human orbitofrontal cortex to a liquid food stimulus is correlated with its subjective pleasantness. *Cerebral Cortex*, 13, 1064–71.
- Kubanis, P. and Zornetzer, S.F. (1981). Age-related behavioural and neurobiological changes: a review with an emphasis on memory. *Behavioural and Neural Biology*, 31, 115–72.
- Kuperberg, G. and Heckers, S. (2000). Schizophrenia and cognitive function. *Current Opinion in Neurobiology*, 10, 2, 205–10.
- Kuskowski, M.A. and Pardo, J.V. (1999). The role of the fusiform gyrus in successful encoding of face stimuli. *Neuroimage*, 9, 599–610.
- Kutas, M., Federmeier, K.D., Coulson, S., King, J. and Munte, T.F. (2000). Language. In E. John, T. Cacioppo, E. Louis and G. Tassinary (eds), *Handbook of Psychophysiology* (2nd edition). Cambridge: Cambridge University Press.
- Kutas, M. and Hillyard, S.A. (1980). Reading senseless sentences: brain potentials reflect semantic incongruity. *Science*, 207, 203–5.
- Kutas, M., McCarthy, G. and Donchin, E. (1975). Differences between sinistrals' and dextrals' ability to infer a whole from its parts: a failure to replicate. *Neuropsychologia*, 13, 455–64.
- Kutas, M. and Van Petten, C. (1994). Psycholinguistics electrified. In M. Gernsbacher (ed.), *Handbook of Psycholinguistics*. San Diego: Academic Press.
- Kyllonen, P.C. (2002). G: Knowledge, speed, strategies or working memory capacity? A systems perspectives. In R.J. Sternberg and E.L. Gigorenko (eds), *The General Factor of Intelligence: How General Is It?* Mahwah, NJ: Lawrence Erlbaum.
- Ladavas, E. (1994). The role of visual attention in neglect: a dissociation between perceptual and directional motor neglect. In P.W. Halligan and J.C. Marshall (eds), *Spatial Neglect: Position Papers on Theory and Practice*. Hove, UK: Lawrence Erlbaum.
- Lader, M.H. and File, S.E. (1987). The biological basis of benzodiazepine dependence. *Psychological Medicine*, 17, 539–47.
- Laitinen, L.V., Bergenheim, A.T. and Hariz, M.I. (1992). Leskell's posteroventral pallidotomy in the treatment of Parkinson's disease. *Journal of Neurosurgery*, 77, 487–8.
- Lamantia, A.-S. and Rakic, P. (1990). Cytological and quantitative characteristics of four cerebral commissures in the rhesus monkey. *Journal of Comparative Neurology*, 291, 520–37.
- Lambert, A.J. (1991). Interhemispheric interaction in the split-brain. *Neuropsychologia*, 29, 941–8.
- Lambon Ralph, M.A. (2004). Reconnecting cognitive neuropsychology: commentary on Harley's Does cognitive neuropsychology have a future? *Cognitive Neuropsychology*, 21, 1, 31–5.
- Landis, T., Cummings, J.L., Benson, F. and Palmer, E.P. (1986). Loss of topographic familiarity: an environmental agnosia. *Archives of Neurology* (Chicago), 43, 132–6.
- Langston, J.W. (1985). Mechanism of MPTP toxicity: more answers, more questions. *Trends in Pharmacological Sciences*, 6, 375–8.
- Lang, P.J., Davis, M. and Ohman, A. (2000). Fear and anxiety: animal models and human cognitive

- psychophysiology. *Journal of Affective Disorders*, 61, 137–59.
- Lansky, L.M., Feinstein, H. and Peterson, J.M. (1988). Demography of handedness in two samples of randomly selected adults ($N = 2083$). *Neuropsychologia*, 26, 465–77.
- Lapierre, D., Braun, C.M.J. and Hodgins, S. (1995). Ventral frontal deficits in psychopathy: neuropsychological test findings. *Neuropsychologia*, 33, 2, 139–51.
- Larrabee, G.J. (1990). Cautions in the use of neuropsychological evaluation in legal settings. *Neuropsychology*, 4, 239–47.
- Lashley, K.S. (1938). Factors limiting recovery after central nervous lesions. *Journal of Nervous and Mental Diseases*, 88, 733–55.
- Lashley, K.S. (1951). The problem of serial order in behaviour. In L.A. Jeffries (ed.), *Cerebral Mechanisms in Behaviour: The Hixon Symposium*. New York: John Wiley & Sons.
- Lasonde, M., Sauerwein, H., Chicoine, A.-J. and Geoffroy, G. (1991). Absence of disconnection syndrome in callosal genesis and early callosotomy: brain reorganization or lack of structural specificity during ontogeny? *Neuropsychologia*, 29, 481–95.
- Lawrie, S.M. and Abukmeil, S.S. (1998). Brain abnormality in schizophrenia: a systematic and quantitative review of volumetric magnetic resonance imaging studies. *British Journal of Psychiatry*, 172, 110–20.
- Lawson, R. (1878). On the symptomatology of alcoholic brain disorders. *Brain*, 1, 182–94.
- Lazarus, R.S. (1966). *Psychological Stress and the Coping Process*. New York: McGraw-Hill.
- Leach, L., Kaplan, E., Rewilak, D., Richards, B. and Proulx, G.-B. (2000). *Kaplan–Baycrest Neurocognitive Assessment*. San Antonio: Psychological Corporation.
- Lechevalier, B., Aupee, A.M., de la Sayette, V., Eustache, F. and Baron, J.C. (2000). Functional imaging of the hippocampus in Korsakoff's syndrome. *Bulletin of the National Academy of Medicine*, 184, 1491–7.
- LeDoux, J.E. (1987). Emotion. In F. Plum and V.B. Mountcastle (eds), *Handbook of Physiology V. The Nervous System: Higher Functions of the Brain*. Washington: American Physiological Society.
- LeDoux, J.E. (1995a). In search of an emotional system in the brain: leaping from fear to emotion and consciousness. In M.S. Gazzaniga (ed.), *The Cognitive Neurosciences*. Cambridge, Mass.: MIT Press.
- LeDoux, J.E. (1995b). Emotion: clues from the brain. *Annual Review of Psychology*, 46, 209–35.
- LeDoux, J.E., Cicchetti, P., Xagoraris, A. and Romanski, L.M. (1990). The lateral amygdaloid nucleus: sensory interface of the amygdala in fear conditioning. *Journal of Neuroscience*, 10, 1062–9.
- LeDoux, J.E., Sakaguchi, A. and Reis, D.J. (1984). Subcortical efferent projections of the medial geniculate nucleus mediate emotional responses conditioned by acoustic stimuli. *Journal of Neuroscience*, 4, 3, 683–98.
- Lee, G.P. (2004). Differential diagnosis in epilepsy. In J.H. Ricker (ed.), *Differential Diagnosis in Adult Neuropsychological Assessment*. New York: Springer.
- Lee, J.L.C., Everitt, B.J. and Thomas, K.L. (2004). Independent cellular processes for hippocampal memory consolidation and reconsolidation. *Science*, 304, 839–43.
- LeGal, P.M. and Bruce, V. (2002). Evaluating the independence of sex and expression in judgements of faces. *Perception and Psychophysics*, 64, 230–43.
- LeGrand, R., Mondloch, C.J., Maurer, D. and Brent, H.P. (2001). Early visual experience and face processing. *Nature*, 410, 890.
- Lehmkuhl, G., Poeck, K. and Willmes, K. (1983). Ideomotor apraxia and aphasia: an examination of types and manifestations of apraxic syndromes. *Neuropsychologia*, 21, 199–212.
- Lehto, J. (1996). Are executive function tests dependent on working memory capacity? *Quarterly Journal of Experimental Psychology*, 49A, 1, 29–50.
- Leibovici, D., Ritchie, K., Ledesert, B. et al. (1996). Does education level determine the course of cognitive decline? *Age and Ageing*, 25, 392–7.
- Leiguarda, R.C. and Marsden, C.D. (2000). Limb apraxias. Higher-order disorders of sensori-motor integration. *Brain*, 123, 860–79.
- Leng, N.R.C. and Parkin, A.J. (1990). The assessment of memory disorders: a review of some current clinical tests. *Clinical Rehabilitation*, 4, 159–65.
- Leng, N.R.C. and Parkin, A.J. (1995). The detection of exaggerated or simulated memory disorder by neuropsychological methods. *Journal of Psychosomatic Research*, 39, 6, 767–76.
- Lenneberg, E. (1967). *The Biological Foundations of Language*. New York: John Wiley & Sons.
- Lesch, K.-P., Bengel, D., Heils, A., Sabol, S.Z., Greenberg, B.D. and Petri, S. (1996). Association of anxiety-related traits with a polymorphism in the serotonin transporter gene regulatory region. *Science*, 274, 1527–31.
- Leslie, A.M. (1987). Pretense and representation: the origins of 'theory of mind'. *Psychological Review*, 94, 412–26.
- Levav, M., Mirsky, A.F., French, L.M. and Bartko, J.J. (1998). Multinational neuropsychological testing: performance of children and adults. *Journal of Clinical and Experimental Neuropsychology*, 20, 5, 658–72.
- LeVere, T.E. (1980). Recovery of function after brain damage: a theory of the behavioural deficit. *Physiological Psychology*, 8, 297–308.
- Levin, H.S. and Benton, A.L. (1986). Neuropsychological assessment. In A.B. Baker and R.J. Joynt (eds), *Clinical Neurology*, Vol. 1. New York: Harper & Row.

- Levin, H.S., Benton, A.L. and Grossman, R.G. (1982). *Neurobehavioural Consequences of Closed Head Injury*. New York: Oxford University Press.
- Levin, H.S., Culhane, K.A., Hartmann, J., Evankovich, K., Mattson, A.J., Harward, H., Ringholtz, G., Ewing-Cobbs, L. and Fletcher, J.M. (1991). Developmental changes in performance on tests of purported frontal lobe functioning. *Developmental Neuropsychology*, 7, 3, 377–95.
- Levin, H.S., Grossman, R.G., Rose, J.E. and Teasdale, G. (1979). Long-term neuropsychological outcome of closed head injury. *Journal of Neurosurgery*, 50, 412–22.
- Levine, D.N. (1978). Prosopagnosia and visual object agnosia: a behavioural study. *Brain and Language*, 10, 224–42.
- Levy, J. (1969). Possible basis for the evolution of lateral specialization in the human brain. *Nature*, 224, 614–15.
- Levy, J. (1974). Psychobiological implications of bilateral asymmetry. In S. Dimond and G. Beaumont (eds), *Hemispheric Function in the Human Brain*. New York: Halstead Press.
- Levy, J. (1990). The regulation and generation of perception in the asymmetric brain. In C. Trevarthen (ed.), *Brain Circuits and Functions of the Mind: Essays in Honour of Roger Sperry*. Cambridge: Cambridge University Press.
- Levy, J., Heller, W., Banich, M. and Burton, L. (1983). Asymmetry of perception in free viewing of chimeric faces. *Brain and Cognition*, 2, 404–19.
- Levy, J. and Trevarthen, C. (1976). Metacognition of hemispheric function in human split-brain patients. *Journal of Experimental Psychology: Human Perception and Performance*, 2, 299–312.
- Levy, J., Trevarthen, C. and Sperry, R.W. (1972). Perception of chimeric bilateral figures following hemispheric disconnection. *Brain*, 95, 61–78.
- Levy, L.M., Henkin, R.I., Hutter, A., Lin, C.S. and Schellinger, D. (1999). Mapping brain activation to odorants in patients with smell loss by functional MRI. *Journal of Computer Assisted Tomography*, 22, 96–103.
- Lewis, J.W., Wightman, F.L., Breczynski, J.A., Phinney, R.E., Binder, J.R. and DeYoe, E.A. (2004). Human brain regions involved in recognizing environmental sounds. *Cerebral Cortex*, 14, 1008–21.
- Lewis, N.D.C., Landis, C. and King, H.E. (1956). *Studies in Topectomy*. New York: Grune and Stratton.
- Lezak, M.D. (1988). IQ: RIP. *Journal of Clinical and Experimental Neuropsychology*, 10, 351.
- Lezak, M.D. (1995). *Neuropsychological Assessment* (3rd edition). New York: Oxford University Press.
- Lezak, M.D., Howieson, D.B. and Loring, D.W. (2004). *Neuropsychological Assessment*, 4th edition. New York: Oxford University Press.
- Lhermitte, F. (1983). Utilization behaviour and its relation to lesions of the frontal lobes. *Brain*, 106, 237–55.
- Lhermitte, F. and Pillon, B. (1975). La prosopagnosie: rôle de l'hémisphère droit dans la perception visuelle. *Revue de Neurologie*, 131, 791–812.
- Lhermitte, F., Pillon, B. and Serdaru, M. (1986). Human autonomy and the frontal lobes. Part I: Imitation and utilization behaviour – a neuropsychological study of 75 patients. *Annals of Neurology*, 19, 326–34.
- Li, S.-C., Lindenberger, U. and Sikstrom, S. (2001). Aging cognition: from neuromodulation to representation. *Trends in Cognitive Sciences*, 5, 11, 479–86.
- Lieberman, I.Y., Mann, V.A., Shankweiler, D. and Werfelman, M. (1982). Children's memory for recurring linguistic and non-linguistic material in relation to reading ability. *Cortex*, 18, 367–75.
- Liberzon, I., Talor, S.F. and Amdur, R. (1999). Brain activation in PTSD in response to trauma-related stimuli. *Biological Psychiatry*, 45, 817–26.
- Lidow, M.S., Williams, G.V. and Goldman-Rakic, P.S. (1998). The cerebral cortex: a case for a common site of action of antipsychotics. *Trends in Pharmacological Sciences*, 19, 136–40.
- Lieberman, J.A., Perkins, D., Belger, A., Chakos, M. and Jarskog, F. (2001). The early stages of schizophrenia: speculations on pathogenesis, pathophysiology, and therapeutic approaches. *Biological Psychiatry*, 50, 11, 884–97.
- Liepmann, H. (1900). Das Krankheitsbild der Apraxie (motorische Asymbolie). *Monatsschrift für Psychiatrie und Neurologie*, 8, 15–44, 102–32, 182–97.
- Liepmann, H. (1905). Der weitere Krankheitsverlauf bei dem einseitig Apraktischen und der Gehirnbefund auf Grund von Serienschnitten. *Monatsschrift für Psychiatrie und Neurologie*, 17, 283–311.
- Liepmann, H. (1920). Apraxia. *Ergebnisse der Gesamten Medizin*, 1, 516–43.
- Liepmann, H. and Maas, O. (1907). Fall von linksseitiger Agraphie und Apraxie bei rechtsseitiger Lahmung. *Z. Psychologie und Neurologie*, 10, 214–27.
- Light, L.L. (1991). Memory and aging: four hypotheses in search of data. *Annual Review of Psychology*, 42, 538–59.
- Lindvall, O., Rehnström, S. and Brundin, P. (1989). Human fetal dopamine neurons grafted into the striatum in two patients with severe Parkinson's disease. *Archives of Neurology*, 46, 615–31.
- Linn, M.C. and Petersen, A.A. (1985). Emergence and characterization of sex differences in spatial ability: a meta-analysis. *Child Development*, 59, 1479–98.
- Lissauer, H. (1890). Ein Fall von Seelenblindheit nebst einem Beitrag zur Theorie derselben. *Archiv für Psychiatrie*, 21, 222–70.
- Llorca, P.M., Spadone, C. and Sol, O. (2002). Efficacy and safety of hydroxyzine in the treatment of general-

- ized anxiety disorder: a 3-month double-blind study. *Journal of Clinical Psychiatry*, 63, 1020–7.
- Lomo, T. (1966). Frequency potentiation of excitatory synaptic activity in the dentate area of the hippocampal formation. *Acta Physiologica Scandinavica*, 68, 128.
- Lowin, A., Knapp, M.R.J. and McCrone, P. (2001). Alzheimer's disease in the UK: Comparative evidence on cost of illness and volume of health services research funding. *International Journal of Geriatric Psychiatry*, in press.
- Luciana, M. and Nelson, C.A. (1998). The functional emergence of prefrontally-guided working memory systems in four- to eight-year-old children. *Neuropsychologia*, 36, 273–93.
- Luck, S., Chelazzi, L., Hillyard, S. and Desimone, R. (1993). Effects of spatial attention on responses of V4 neurons in the macaque. *Society for Neuroscience Abstracts*, 69, 27.
- Ludlow, C. (1977). Recovery from aphasia: a foundation for treatment. In M.A. Sullivan and M.S. Kommers (eds), *Rationale for Adult Aphasia Therapy*. Lincoln: University of Nebraska Medical Center.
- Lundberg, I., Olofsson, A. and Wall, S. (1980). Reading and spelling skills in the first school years predicted from phonemic awareness skill in kindergarten. *Scandinavian Journal of Psychology*, 21, 159–73.
- Luria, A.R. (1959). Disorders of 'simultaneous perception' in a case of bilateral occipitoparietal brain injury. *Brain*, 83, 437–49.
- Luria, A.R. (1963). *Recovery of Function after Brain Injury*. Macmillan: New York.
- Luria, A.R. (1966). *Higher Cortical Functions in Man*. London: Tavistock.
- Luria, A.R. (1970). The functional organization of the brain. *Scientific American*, 222, 3.
- Luria, A.R. (1972). *The Man with the Shattered World*. New York: Basic Books.
- Luria, A.R. (1973). *The Working Brain*. London: Penguin.
- Luria, A.R., Naydin, V.L., Tsvetkova, L.S. and Vinarskaya, E.N. (1969). Restoration of higher cortical function following local brain damage. In P.J. Vinken and G.W. Bruyn (eds), *Handbook of Clinical Neurology*, Vol. 3. Amsterdam: North-Holland.
- Lynch, G., Muller, D., Seubert, P. and Larson, J. (1988). Long-term potentiation: persisting problems and recent results. *Brain Research Bulletin*, 21, 363–72.
- Lynn, R. and Dai, X.Y. (1993). Sex differences on the Chinese standardization sample of the WAIS-R. *Journal of Genetic Psychology*, 75, 459–63.
- Machiyama, Y., Watanabe, Y. and Machiyama, R. (1987). Neuroanatomical studies of the corpus callosum in schizophrenia: evidence of aberrant interhemispheric fibre connections. In R. Takahashi, P. Flor-Henry and S. Niwa (eds), *Cerebral Dynamics: Laterality and Psychopathology*. New York: Elsevier.
- MacKay, D.G., Stewart, R. and Burke, D.M. (1998). HM revisited: relations between language comprehension, memory and the hippocampal system. *Journal of Cognitive Neuroscience*, 10, 3, 377–94.
- MacLean, M., Bryant, P.E. and Bradley, L. (1987). Rhymes, nursery rhymes and reading in early childhood. *Merrill–Palmer Quarterly*, 33, 255–82.
- MacSweeney, M. et al. (2002). Neural correlates of British Sign Language comprehension: spatial correlates of topographic language. *Journal of Cognitive Neuroscience*, 14, 1064–75.
- Maestu, F., Saldana, C., Amo, C., Gonzales-Hidalgo, M., Fernandez, A., Fernandez, S., Mata, P., Papanicolaou, A. and Ortiz, T. (2004). Can small lesions induce language reorganization as large lesions do? *Brain and Language*, 89, 433–8.
- Maguire, E.A., Burgess, N., Donnett, J.G., Frackowiak, R.S.J., Frith, C.D. and O'Keefe, J. (1998). Knowing where and getting there: a human navigation network. *Science*, 280, 921–4.
- Maguire, E.A., Frackowiak, R.S.J. and Frith, C.D. (1997). Recalling routes around London: Activation of the right hippocampus in taxi drivers. *Journal of Neuroscience*, 17, 7103.
- Mahmood, T., Reveley, A.M. and Murray, R.M. (1983). Genetic studies of affective and anxiety disorders. In M. Weller (ed.), *The Scientific Basis of Psychiatry*. London: Ballière/Tindal.
- Maier, M. (1995). In vivo magnetic resonance spectroscopy: application in psychiatry. *British Journal of Psychiatry*, 167, 299–306.
- Malhotra, P., Mannan, S., Driver, J. and Husain, M. (2004). Impaired spatial working memory: one component of the visual neglect syndrome? *Cortex*, 40, 667–76.
- Malone, K. and Mann, J.J. (1993). Serotonin and major depression. In J.J. Mann and D.J. Kupfer (eds), *Biology of Depressive Disorders, Part A: A Systems Perspective*. New York: Plenum.
- Mammucari, A., Caltagirone, C., Ekman, P., Friesen, W., Gianotti, G., Pizzamiglio, L. and Zoccolotti, P. (1988). Spontaneous facial expression of emotions in brain-damaged patients. *Cortex*, 24, 521–33.
- Mandler, G. (1980). Recognising: the judgement of previous occurrence. *Psychological Review*, 87, 252–71.
- Manes, F., Sahakian, B., Clark, L., Rogers, R., Antoun, N., Aitken, M. and Robbins, T. (2002). Decision-making processes following damage to the prefrontal cortex. *Brain*, 125, 624–39.
- Manly, J.J., Jacobs, D.M., Sano, M., Bell, K., Merchant, C.A. and Small, S.A. (1998). Cognitive test performance among nondemented elderly African Americans and whites. *Neurology*, 50, 1238–45.
- Manly, T., Robertson, I., Anderson, V. and Nimmo-Smith, I. (1999). *The Test of Everyday Attention for Children*. Cambridge: Thames Valley Test Corporation.

- Mann, D.M.A., Yates, P.O. and Hawkes, J. (1982). The noradrenergic system in Alzheimer and multi-infarct dementias. *Journal of Neurology, Neurosurgery and Psychiatry*, 45, 113–19.
- Mar, R. (2004) The neuropsychology of narrative story comprehension, story production and their interrelation. *Neuropsychologia*, 42, 10, 1414–34.
- Marcopulos, B.A., McLain, C.A. and Giuliano, A.J. (1997). Cognitive impairment or inadequate norms? A study of healthy, rural, older adults with limited education. *The Clinical Neuropsychologist*, 11, 2, 111–31.
- Mark, V.W., Kooistra, C.A. and Heilman, K.M. (1988). Hemispatial neglect affected by non-neglected stimuli. *Neurology*, 38, 1207–11.
- Marks, I.M. (1986). Genetics of fear and anxiety disorders. *British Journal of Psychiatry*, 149, 406–18.
- Markus, H.S. and Boland, M. (1992). ‘Cognitive activity’ monitored by non-invasive measurement of cerebral blood flow velocity and its application to the investigation of cerebral dominance. *Cortex*, 28, 575–81.
- Margell, L.B., Rush, A.J., George, M.S., Sackheim, H.A. and Johnson, C.R. (2002). Vagus nerve stimulation for major depressive episodes: one year outcomes. *Biological Psychiatry*, 51, 280–7.
- Marr, D. (1982). *Vision*. San Francisco: W.H. Freeman.
- Marsh, G.G. and Philwin, B. (1987). Unilateral neglect and constructional apraxia in a right-handed artist with a left posterior lesion. *Cortex*, 23, 1, 149–55.
- Marshall, J., Atkinson, J., Smulovitch, E., Thacker, A. and Woll, B. (2004). Aphasia in a user of British Sign Language: dissociation between sign and gesture. *Cognitive Neuropsychology*, 21, 5, 537–54.
- Marshall, J.C. and Halligan, P.W. (1988). Blindsight and insight in visuospatial neglect. *Nature*, 336, 766–7.
- Marshall, J.C. and Halligan, P.W. (1994). Left in the dark. In P.W. Halligan and J.C. Marshall (1994). *Spatial Neglect: Position Papers on Theory and Practice*. Hove, UK: Lawrence Erlbaum.
- Marshall, J.C. and Halligan, P.W. (1995). Seeing the forest but only half the trees. *Nature*, 373, 521–3.
- Marshall, J.C. and Halligan, P.W. (1996). Hemispheric antagonism in visuo-spatial neglect: a case study. *Journal of the International Neuropsychological Society*, 2, 412–18.
- Marshall, J.C. and Newcombe, F. (1966). Syntactic and semantic errors in paralexia. *Neuropsychologia*, 4, 169–76.
- Marshall, J.C. and Newcombe, F. (1973). Patterns of paralexia. *Journal of Psycholinguistic Research*, 2, 175–99.
- Marslen-Wilson, W. and Tyler, L.K. (1998). Rules, representations and the English past tense. *Trends in Cognitive Sciences*, 2, 11, 428–35.
- Martin, A. and Chao, L.L. (2001). Semantic memory and the brain: structure and processes. *Current Opinion in Neurobiology*, 11, 194–201.
- Martin, A., Wiggs, C.L., Ungerleider, G. and Haxby, J.V. (1996). Neural correlates of category-specific knowledge. *Nature*, 379, 649–52.
- Martin, C.O., Denburg, N.L., Tranel, D., Granner, M.A. and Bechara, A. (2004). The effects of vagus nerve stimulation on decision-making. *Cortex*, 40, 605–12.
- Martin, G.N. (1996). Olfactory remediation: current evidence and possible applications. *Social Science and Medicine*, 43, 1, 63–70.
- Martin, G.N. (1998). Human electroencephalographic (EEG) response to olfactory stimulation: Two experiments using the aroma of food. *International Journal of Psychophysiology*, 30, 287–302.
- Martin, G.N. (2000). There’s more neuroscience. *American Psychologist*, 55, 2, 275–6.
- Martin, G.N. (2003). *Essential biological psychology*. London: Hodder Arnold.
- Martin, G.N. (2004). A neuroanatomy of flavour. *Petits Propos Culinaires*, 76, 58–81.
- Martin, G.N. and Gray, C.D. (1996). The effects of audience laughter on men’s and women’s responses to humour. *Journal of Social Psychology*, 136, 2, 221–31.
- Martin, N. (2002). PV and PB: two cognitive neuropsychological studies of phonological STM impairment and their impact on theories of language and memories. In E. Funnell (ed.), *Case Studies in the Neuropsychology of Reading*. Hove, UK: Psychology Press.
- Martin, N. and Saffran, E.M. (1992). A computational account of deep dysphasia: evidence from a single case study. *Brain and Language*, 43, 240–74.
- Martin, R.C. (2003). Language processing: functional organization and neuroanatomical basis. *Annual Review of Psychology*, 54, 55–89.
- Martin, R.C., Franzen, M.D. and Orey, S. (1998). Magnitude of error as a strategy to detect feigned memory impairment. *The Clinical Neuropsychologist*, 12, 1, 84–91.
- Marzi, C.A., Tassinari, G., Aglioti, S. and Lutzemberger, L. (1986). Spatial summation across the vertical meridian in hemianopsics: a test of blindsight. *Neuropsychologia*, 24, 749–58.
- Massana, G., Serra-Grabulosa, J.M. and Salgado-Pineda, P. (2003). Parahippocampal grey matter density in panic disorder: a voxel-based morphometric study. *American Journal of Psychiatry*, 160, 566–8.
- Maviel, T., Durkin, T.P., Menzaghi, F. and Bontempi, B. (2004). Site of neocortical reorganization critical for remote spatial memory. *Science*, 305, 96–9.
- Mayall, K.A. and Humphreys, G.W. (1996). A connectionist model of alexia: covert recognition and case mixing effects. *British Journal of Psychology*, 87, 355–402.
- Mayes, A.R. (1988). The memory problems caused by frontal lobe lesions. In A.R. Mayes (ed.), *Human Organic Memory Disorders*. Cambridge: Cambridge University Press.

- Mayes, A.R., Isaac, C.L., Holdstock, J.S., Cariga, P., Gummer, A. and Roberts, N. (2003). Long-term amnesia: a review and detailed illustrative case study. *Cortex*, 39, 567–603.
- Mayeux, R., Saunders, A.M., Shea, S., Mirra, S., Evans, D. and Roses, A.D. (1998). Utility of the apolipoprotein E genotype in the diagnosis of Alzheimer's disease. *New England Journal of Medicine*, 338, 506–11.
- Maylor, E.A. (1996). Older people's memory for the past and the future. *The Psychologist*, October, 456–9.
- Mazmanian, P.E., Martin, K.O. and Kreutzer, J.S. (1991). Professional development and educational program planning in cognitive rehabilitation. In J.S. Kreutzer and P.H. Wehman (eds), *Cognitive Rehabilitation for Persons with Traumatic Brain Injury*. Baltimore: Brookes.
- Mazziotta, J.C., Grafton, S.T. and Woods, R.P. (1991). The human motor system studied with PET measurements of cerebral blood flow: Topography and motor learning. *Brain Works II*, 31, 280–93.
- Mazzocchi, F. and Vignolo, L.A. (1979) Localization of lesions in aphasia: clinical CT scan correlations in stroke patients. *Cortex*, 15, 627–54.
- McCandliss, B.D., Cohen, L. and Dehaene, S. (2003). The visual word form area: expertise for reading in the fusiform gyrus. *Trends in Cognitive Sciences*, 7, 293–9.
- McCarthy, R.A. (2001). Is the mind a cauliflower or an onion? British insights into cognitive organization from the study of abnormal function. *British Journal of Psychology*, 92, 171–92.
- McCarthy, R.A. and Warrington, E.K. (1986). Visual associative agnosia: a clinico-anatomical study of a single case. *Journal of Neurology, Neurosurgery and Psychiatry*, 49, 1233–40.
- McCarthy, R.A. and Warrington, E.K. (1988). Evidence for modality specific meaning systems in the brain. *Nature*, 334, 428–30.
- McCarthy, R.A. and Warrington, E.K. (1990). *Cognitive Neuropsychology: A Clinical Introduction*. New York: Academic Press.
- McCloskey, M. (2004). Does Harley have a point? Comments on Harley's Does cognitive neuropsychology have a future? *Cognitive Neuropsychology*, 21, 1, 37–9.
- McCloskey, M., Aliminosa, D. and Sokol, S.M. (1991). Facts, rules, and procedures in normal calculation: evidence from multiple single-patient studies of impaired arithmetic fact retrieval. *Brain and Cognition*, 17, 154–203.
- McCrorry, E., Frith, U., Brunswick, N. and Price, C. (2000). Abnormal functional activation during a simple word repetition task: a PET study of adult dyslexics. *Journal of Cognitive Neuroscience*, 12, 753–62.
- McCrorry, E., Mechelli, A., Frith, U. and Price, C. (2005). More than words: a common neural basis for reading and naming deficits in developmental dyslexia? *Brain*, 128, 261–7.
- McCulloch, W. (1949). Mechanisms for the spread of epileptic activation in the brain. *Electroencephalography and Clinical Neurophysiology*, 1, 19–24.
- McDermott, K.B., Petersen, S.E., Watson, J.M. and Ojemann, J.G. (2003). A procedure for identifying regions preferentially activated by attention to semantic and phonological relations using functional magnetic resonance imaging. *Neuropsychologia*, 41, 293–303.
- McGhee, M.G. (1979). Human spatial abilities: psychometric studies and environmental, genetic, hormonal and neurological influences. *Psychological Bulletin*, 86, 889–918.
- McGlone, J. (1980) Sex differences in human brain asymmetry: a critical survey. *Behavioural and Brain Sciences*, 5, 215–64.
- McGuire, P.K., Queded, D.J., Spence, S.A., Murray, R.M., Frith, C.D. and Liddle, P.F. (1998). Pathophysiology of 'positive' thought disorder in schizophrenia. *British Journal of Psychiatry*, 173, 231–5.
- McGuire, P.K., Silbersweig, D.A., Wright, I., Murray, R.M., Frackowiak, R.S.J. and Frith, C.D. (1996). The neural correlates of inner speech and auditory verbal imagery in schizophrenia: relationship to auditory verbal hallucinations. *British Journal of Psychiatry*, 169, 148–59.
- McKeever, W.F. (1986). The influences of handedness, sex, familial sinistrality, and androgyny on language laterality, verbal ability and spatial ability. *Cortex*, 22, 521–37.
- McKeever, W.F. (1991). Handedness, language laterality and spatial ability. In F.L. Kitterle (ed.), *Cerebral Laterality: Theory and Research*. Hillsdale, NJ: Lawrence Erlbaum.
- McKhann, G., Drachman, D., Folstein, M., Katzman, R., Price, D. and Stadlan, E.M. (1984). Clinical diagnosis of Alzheimer's disease: report of the NINCDS-ADRDA Work Group under the auspices of the Department of Health and Human Services Task Force on Alzheimer's disease. *Neurology*, 34, 939–44.
- McLellan, D.L. (1991). Functional recovery and the principles of disability medicine. In M. Swash and J. Oxbury (eds), *Clinical Neurology*. Edinburgh: Churchill Livingstone.
- McManus, I.C. (1985). Handedness, language dominance and aphasia: a genetic model. *Psychological Medicine*, 8, 1–40.
- McManus, I.C., Shergill, S. and Bryden, M.P. (1993). Annett's theory that individuals heterozygous for the right shift gene are intellectually advantaged: theoretical and empirical problems. *British Journal of Psychology*, 84, 517–37.
- McNamee, P., Bond, J. and Buck, D. (2001). Costs of dementia in England and Wales in the 21st century. *British Journal of Psychiatry*, 179, 261–6.

- McNeil, T.F., Cantor-Graae, E. and Weinberger, D.R. (2000). Relationship of obstetric complications and differences in size of brain structures in monozygotic twin pairs discordant for schizophrenia. *American Journal of Psychiatry*, 157, 2, 203–12.
- McPherson, S.E. and Cummings, J.L. (1996). Neuropsychological aspects of vascular dementia. *Brain and Cognition*, 31, 269–82.
- Meador, K.J., Allen, M.E., Adams, R.J. and Loring, D.W. (1991). Allochiria vs allesthesia. Is there a misrepresentation? *Archives of Neurology*, 48, 546–9.
- Meadows, J.C. (1974). The anatomical basis of prosopagnosia. *Journal of Neurology, Neurosurgery and Psychiatry*, 37, 489–501.
- Meeter, M. and Murre, J.M.J. (2004). Tracelink: a model of consolidation and amnesia. *Cognitive Neuropsychology*, in press.
- Mehta, Z. and Newcombe, F. (1991). A role for the left hemisphere in spatial processing. *Cortex*, 27, 153–67.
- Melamed, E., Lavy, S., Shlomo, B., Cooper, G. and Rinot, Y. (1980). Reduction in regional cerebral blood flow during normal aging in man. *Stroke*, 11, 1, 31–4.
- Menn, L. (2001). *Comparative Aphasiology: Cross-Language Studies of Aphasia*. Amsterdam: Elsevier Science.
- Menon, V., Rivera, S.M., White, C.D., Glover, G.H. and Reiss, A.L. (2000). Dissociating prefrontal and parietal cortex activation during arithmetic processing. *Neuroimage*, 12, 357–65.
- Mesulam, M.M. (1986). Frontal cortex and behaviour. *Annals of Neurology*, 19, 320–5.
- Mesulam, M.M. (1990). Large scale neurocognitive networks and distributed processing for attention, language and memory. *Annals of Neurology*, 28, 597–613.
- Miller, B.L., Darby, A., Benson, D.F., Cummings, J.L. and Miller, M.H. (1997). Aggressive, socially disruptive, and antisocial behaviour in frontotemporal dementia. *British Journal of Psychiatry*, 170, 150–6.
- Miller, E. (1984). *Recovery and Management of Neuropsychological Impairments*. Chichester, UK: John Wiley & Sons.
- Milner, A.D. and Goodale, M.A. (1993). Visual pathways to perception and action. In T.P. Hicks, S. Molotchnikoff and T. Ono (eds), *Progress in Brain Research*. Amsterdam: Elsevier.
- Milner, B. (1958). Psychological deficits produced by temporal-lobe excision. *Research Publications/Association for Research in Nervous and Mental Disease*, 36, 244–57.
- Milner, B. (1963). Effects of different brain lesions on card sorting. *Archives of Neurology*, 9, 90–100.
- Milner, B. (1964). Some effects of frontal lobectomy in man. In J.M. Warren and G. Akert (eds), *The Frontal Granular Cortex and Behaviour*. New York: McGraw-Hill.
- Milner, B., Corkin, S. and Teuber, H.-L. (1968). Further analysis of the hippocampal amnesic syndrome: 14 year follow-up study of HM. *Neuropsychologia*, 6, 217–24.
- Mirsen, T. and Hachinski, V. (1988). Epidemiology and classification of vascular and multi-infarct dementia. In J.S. Meyer, H. Lechner, J. Marshall and J.F. Toole (eds), *Vascular and Multi-infarct Dementia*. Mount Kisco, NY: Future Publishing.
- Mittenberg, W., Zielinski, R.E., Fichera, S.M. and Heilbronner, R.L. (1995). Identification of malingered head injury on the Wechsler Adult Intelligence Scale – Revised. *Professional Psychology: Research and Practice*, 26, 491–8.
- Mohr, J.P., Pessin, M.S., Finkelstein, S., Funkenstein, H.H., Duncan, G.W. and Davis, K.R. (1978). Broca's aphasia: pathologic and clinical aspects. *Neurology*, 28, 311–24.
- Morgan, D.L. and Morgan, R.K. (2001). Single-participant research design. *American Psychologist*, 56, 2, 119–27.
- Moriguchi, Y., Ohnishi, T., Kawachi, T., Mori, T., Hirakata, M., Yamada, M., Matsuda, H. and Komaki, G. (2005). Specific brain activation in Japanese and Caucasian people to fearful faces. *NeuroReport*, 16, 2, 133–6.
- Morris, J.S., de Bonis, M. and Dolan, R.J. (2002). Human amygdala responses to fearful eyes. *Neuroimage*, 17, 214–22.
- Morris, J.S., Frith, C.D., Perrett, D.I., Rowland, D., Young, A.W., Calder, A.J. and Dolan, R.J. (1996). A differential neural response in the human amygdala to fearful and happy facial expressions. *Nature*, 383, 812–15.
- Morris, R.D., Hopkins, W.D. and Bolser-Gilmore, L. (1993). Assessment of hand preference in two language-trained chimpanzees (*Pan troglodytes*): a multimethod analysis. *Journal of Clinical and Experimental Psychology*, 15, 487–502.
- Morris, R.G., Evenden, J.L., Sahakian, B.J. and Robbins, T.W. (1986). Computer-aided assessment of dementia: comparative studies of neuropsychological deficits in Alzheimer-type dementia and Parkinson's disease. In S.M. Stahl, S.D. Iversen and E.C. Goodman (eds), *Cognitive Neurochemistry*. New York: Oxford University Press.
- Morris, R.G., Downes, J.J., Sahakian, B.J., Evenden, J.L., Heald, A. and Robbins, T.W. (1988). Planning and spatial working memory in Parkinson's disease. *Journal of Neurology, Neurosurgery and Psychiatry*, 51, 757–66.
- Morris, R.G.M., Garrud, P., Rawlins, J.N.P. and O'Keefe, J. (1982). Place navigation impaired in rats with hippocampal lesions. *Nature*, 182, 297, 681–3.
- Moss, A.R. and Dowd, T. (1991). Does the NART hold after head injury? A case report. *British Journal of Clinical Psychology*, 30, 179–80.

- Moss, H.E., Tyler, L.K., Durrant-Peatfield, M. and Bunn, E.M. (1998). Two eyes of a see-through: impaired and intact semantic knowledge in a case of selective deficits in living things. *Neurocase*, 4, 291–10.
- Mossner, R., Henneberg, A., Schmitt, A., Sygailo, Y.V., Grassle, M. and Hennig, T. (2001). Allelic variation of serotonin transporter expression is associated with depression in Parkinson's disease. *Molecular Psychiatry*, 6, 3, 350–2.
- Mottaghy, F.M., Doring, T., Muller-Gartner, H.W., Topper, R. and Krause, B.J. (2002). Bilateral parieto-frontal network for verbal working memory: an interference approach using repetitive transcranial magnetic stimulation (rTMS). *European Journal of Neuroscience*, 16, 1627–32.
- Muller, R.A., Rothmel, R.D., Behen, M.E., Muzik, O., Chakroborty, P.K. and Chugani, H.T. (1999). Language organisation in patients with early and late left hemisphere lesion: a PET study. *Neuropsychologia*, 37, 345–57.
- Muller-Hill, B. and Beyreuther, K. (1989). Molecular biology of Alzheimer's disease. *Annual Review of Biochemistry*, 58, 287–307.
- Mummary, C.J., Patterson, K., Price, C.J., Ashburner, J., Frackowiak, R.S.J. and Hodges, J.R. (2000). A voxel-based morphometry study of semantic dementia: relationship between temporal lobe atrophy and semantic memory. *Annals of Neurology*, 47, 36–45.
- Munk, H. (1878). Weitere Mittheilungen zur Physiologie der Grosshirnrinde. *Archives of Anatomy and Physiology*, 3, 581–92.
- Munk, H. (1881). *Über die Funktionen der Grosshirnrinde, Gesammelte Mittheilungen aus den Jahren 1877–1880*. Berlin: Hirshwald.
- Murdoch, B.E., Afford, R.J., Ling, A.R. and Ganguley, B. (1986). Acute computerized tomographic scans: their value in the localization of lesions and as prognostic indicators in aphasia. *Journal of Communication Disorders*, 19, 311–45.
- Musso, M., Weiller, C., Kiebel, S., Muller, S.P., Bulau, P. and Rijntjes, M. (1999). Training-induced brain plasticity in aphasia. *Brain*, 122, 1781–90.
- Myers, R.E. (1956). Function of corpus callosum in interocular transfer. *Brain*, 79, 358–63.
- Myers, R.E. and Sperry, R.W. (1958). Interhemispheric communication through the corpus callosum: mnemonic carry-over between the hemispheres. *Archives of Neurology and Psychiatry*, 80, 298–303.
- Nadel, L. and Moscovitch, M. (1997). Memory consolidation, retrograde amnesia and the hippocampal complex. *Current Opinion in Neurobiology*, 7, 217–27.
- Naeser, M.A., Hayward, R.W., Laughlin, S.A. and Zatz, L.M. (1981) Quantitative CT scan studies in aphasia. I: infarct size and CT numbers. *Brain and Language*, 12, 140–64.
- Nagahama, Y., Fukuyama, H., Yamauchi, H., Matsuzaki, S., Konishi, J., Shibasaki, H. and Kimure, J. (1996). Cerebral activation during performance of a card sorting test. *Brain*, 119, 1667–75.
- Najlerahim, A. and Bowen, D.M. (1988a). Biochemical measurements in Alzheimer's disease reveal a necessity for improved neuroimaging techniques to study metabolism. *Biochemical Journal*, 251, 305–8.
- Najlerahim, A. and Bowen, D.M. (1988b). Regional weight loss of the cerebral cortex and some subcortical nuclei in senile dementia of the Alzheimer type. *Acta Neuropathologica*, 75, 509–12.
- Nakamura, T. *et al.* (2001). Blinded positron emission tomography study of dopamine cell implantation for Parkinson's disease. *Annals of Neurology*, 50, 181–7.
- Nauta, W.J.H. (1971). The problem of the frontal lobe: a reinterpretation. *Journal of Psychiatric Research*, 8, 167–87.
- Nauta, W.J.H. (1973). Connections of the frontal lobe with the limbic system. In L.V. Laitinen and R.E. Livingston (eds), *Surgical Approaches in Psychiatry*. Baltimore: University Park Press.
- Neary, D. and Snowden, J. (1996). Fronto-temporal dementia: nosology, neuropsychology and neuropathology. *Brain and Cognition*, 31, 176–87.
- Nebes, R. (1972). Direct examination of cognitive function in the right and left hemispheres. In M. Kinsbourne (ed.), *Asymmetrical Function of the Brain*. Cambridge: Cambridge University Press.
- Nelson, C.A. (1999). Neural plasticity and human development. *Current Directions in Psychological Science*, 8, 2, 42–5.
- Nelson, H. (1976). A modified card sorting test sensitive to frontal lobe defects. *Cortex*, 12, 313–24.
- Nelson, H.E. (1982). *National Adult Reading Test (NART): Test Manual*. Windsor, UK: NFER/Nelson.
- Nelson, H.E. and O'Connell, A. (1978). Dementia: the estimation of premorbid intelligence. *Journal of Abnormal Psychology*, 93, 321–30.
- Nemeroff, C.B. (2003). Anxiolytics: past, present and future agents. *Journal of Clinical Psychiatry*, 64, suppl 3, 3–6.
- Neubauer, V., Freudenthaler, H.H. and Pfurtscheller, G. (1995). Intelligence and spatiotemporal patterns of event-related desynchronization. *Intelligence*, 3, 249–66.
- Neville, H.J. (1989). Neurobiology of cognitive and language processing: effects of early experience. In K. Gibson and A.C. Petersen (eds), *Brain Maturation and Behavioural Development*. Hawthorn, NY: Aldine Gruyter Press.
- Neville, H.J., Coffey, S.A., Holcomb, P.J. and Tallal, P. (1993). The neurobiology of sensory and language processing in language impaired children. *Journal of Cognitive Neuroscience*, 5, 235–53.

- Newcombe, F. and Marshall, J.C. (1980). Transcoding and lexical stabilisation in deep dyslexia. In M. Coltheart, K.E. Patterson and J.C. Marshall (eds), *Deep Dyslexia*. London: Routledge & Kegan Paul.
- Newcombe, F., Mehta, Z. and de Haan, E.H.F. (1994). Category specificity in visual recognition. In M.J. Farah and G. Ratcliff (eds), *The Neuropsychology of High-level Vision*. Hove, UK: Lawrence Erlbaum.
- Newman, J.P., Patterson, C.M. and Kosson, D.S. (1987). Response perseveration in psychopaths. *Journal of Abnormal Psychology*, 96, 145–8.
- Nichelli, P., Grafman, J., Pietrini, P., Clark, K., Lee, K.Y. and Miletich, R. (1995). Where the brain appreciates the moral of a story. *NeuroReport*, 6, 2309–13.
- Nicolson, R.I., Fawcett, A.J., Berry, E.L., Jenkins, I.H., Dean, P. and Brooks, D.J. (1999). Association of abnormal cerebellar activation with motor learning difficulties in dyslexic adults. *The Lancet*, 353, 1662–7.
- Niedermeyer, E. (1987). The normal EEG of the waking adult. In E. Niedermeyer and F. Lopes DaSilva (eds), *Electroencephalography: Basic principles, clinical applications and related fields*. Germany: Urban and Schwarzenberg.
- Nixon, P., Lazarova, J., Hodinott-Hill, I., Gough, P. and Passingham, R. (2004). The inferior frontal gyrus and phonological processing: an investigation using rTMS. *Journal of Cognitive Neuroscience*, 16, 2, 289–300.
- Nobre, A.C., Allison, T. and McCarthy, G. (1994). Word recognition in the human inferior temporal lobe. *Nature*, 372, 260–3.
- Nobre, A.C. and McCarthy, G. (1994). Language-related ERPs: scalp distributions and modulation by word type and semantic priming. *Journal of Cognitive Neuroscience*, 6, 3, 233–55.
- Nobre, A.C. and McCarthy, G. (1995). Language-related field potentials in the anterior-medial temporal lobe. *Journal of Neuroscience*, 15, 2, 1090–8.
- Norman, D. and Shallice, T. (1986). Attention to action: willed and automatic control of behaviour. In R.J. Davidson, G.E. Schwartz and D. Shapiro (eds), *Consciousness and Self-regulation*, Vol. 4. New York: Plenum.
- Obata, T. *et al.* (2002). Nicotine suppresses 1-methyl-4-phenylpyridinium ion-induced hydroxyl radical generation in rat striatum. *Neuroscience Letters*, 330, 122–4.
- Oberauer, K., Schulze, R., Wilhelm, O. and SuB, H.-M. (2005). Working memory and intelligence – their correlation and their relation: comment on Ackerman, Beier and Boyle (2005). *Psychological Bulletin*, 131, 1, 61–5.
- O’Boyle, M.W. and Benbow, C.P. (1990). Handedness and its relationship to ability and talent. In S. Coren (ed.), *Left-handedness: Behavioural Implications and Anomalies*. Amsterdam: North-Holland.
- O’Carroll, R.E. (1995). The assessment of premorbid ability: a critical review. *Neurocase*, 1, 83–9.
- O’Craven and Kanwisher, N. (2000). Mental imagery of faces and places activates corresponding stimulus-specific brain regions. *Journal of Cognitive Neuroscience*, 12, 6, 1013–23.
- Oddy, M. (1993). Head injury during childhood. *Neuropsychological Rehabilitation*, 3, 4, 301–20.
- Oddy, M. and Cogan, J. (2005). Coping with severe memory impairment. *Neuropsychological Rehabilitation*, 14, 5, 481–94.
- Oddy, M. and Humphrey, M. (1980). Social recovery during the year following severe head injury. *Journal of Neurology, Neurosurgery and Psychiatry*, 43, 798–8.
- Oertel, W.H. and Quinn, N.P. (1996). Parkinsonism. In T. Brandt, L.R. Caplan, J. Dichgans, H.C. Diener and C. Kennard (eds), *Neurological Disorders: Course and Treatment*. New York: Academic Press.
- Ogawa, S., Lee, L.M., Kay, A.R. and Tank, D.W. (1990). Brain magnetic resonance imaging with contrast dependent on blood oxygenation. *Proceedings of the National Academy of Sciences*, 87, 9868–72.
- Ogden, J.A. and McFarlane-Nathan, G. (1997). Cultural bias in the neuropsychological assessment of young Maori men. *New Zealand Journal of Psychology*, 26, 2, 2–12.
- Ohnishi, T., Matsuda, H., Hashimoto, T., Kunihiro, T., Nishikawa, M., Uema, T. and Sasaki, M. (2000). Abnormal regional cerebral blood flow in childhood autism. *Brain*, 123, 1838–44.
- O’Keefe, J. and Nadel, L. (1978). *The Hippocampus as a Cognitive Map*. Oxford: Oxford University Press.
- Okubo, Y., Suhara, T., Suzuki, K., Kobayashi, K., Inoue, O., Terasaki, O., Someya, Y., Sassa, T., Sudo, Y., Matsushima, E., Iyo, M., Tateno, Y. and Toru, M. (1997). Decreased prefrontal dopamine D1 receptors in schizophrenia revealed by PET. *Nature*, 385, 634–6.
- Olanow, C.W., Kordower, J.H. and Freeman, T.B. (1996). Fetal nigral transplantation as a therapy for Parkinson’s disease. *Trends in Neuroscience*, 19, 3, 102–9.
- Olanow, C.W. *et al.* (2003). A double-blind controlled trial of bilateral fetal nigral transplantation in Parkinson’s disease. *Annals of Neurology*, 54, 403–14.
- Oldfield, R.C. (1971). The assessment and analysis of handedness: the Edinburgh Inventory. *Neuropsychologia*, 9, 97–113.
- Olton, D.S., Becker, J.T. and Handelmann, G.E. (1979). Hippocampus, space and memory. *Behavioural and Brain Sciences*, 2, 313–66.
- Ongur, D., Drevets, W.C. and Price, J.L. (1998). Gial reduction in the subgenual prefrontal cortex in mood

- disorders. *Proceedings of the National Academy of Sciences USA*, 95, 13290–5.
- O'Reilly, R.C., Noelle, D.C., Braver, T.S. and Cohen, J.D. (2002). Prefrontal cortex and dynamic categorisation tasks: representational organization and neuromodulatory control. *Cerebral Cortex*, 12, 246–57.
- Orsini, A. and Laicardi, C. (2000). Factor structure of the Italian version of the WAIS-R compared with the American standardization. *Perceptual and Motor Skills*, 90, 1091–100.
- Ortiz, T., Exposito, F.J., Miguel, F., Martin-Loeches, M. and Rubia, F.J. (1992). Brain mapping in dysphonemic dyslexia: in resting and phonemic discrimination conditions. *Brain and Language*, 42, 3, 270–85.
- Ortony, A. and Turner, T.J. (1990). What's basic about basic emotions? *Psychological Review*, 97, 315–31.
- Oscar-Berman, M. (1973). Hypothesis testing and focusing behaviour during concept formation by amnesic Korsakoff patients. *Neuropsychologia*, 11, 191–8.
- Ostergaard, A.L. (1987). Episodic, semantic and procedural memory in a case of amnesia at an early age. *Neuropsychologia*, 25, 341–57.
- Ostrosky-Solis, F., Lopez-Arango, G. and Ardila, A. (2000). Sensitivity and specificity of the Mini-Mental State Examination in a Spanish-speaking population. *Applied Neuropsychology*, 7, 1, 25–31.
- Owen, A.M., Morris, R.G., Sahakian, B.J., Polkey, C.E. and Robbins, T.W. (1996). Double dissociations of memory and executive functions in working memory tasks following frontal lobe excisions, temporal lobe excisions or amygdalo-hippocamectomy in man. *Brain*, 119, 1597–615.
- Pae, C.-U., Choe, B.-Y., Joo, R.-H., Lim, H.-K., Kim, T.-S., Yoo, S.-S., Choi, B.-G., Kim, J.-J., Lee, S.-J., Lee, C., Paik, I.-H. and Lee, C.U. (2004). Neuronal dysfunction of the frontal lobe in schizophrenia. *Neuropsychobiology*, 50, 211–15.
- Paller, K.A., Acharya, A., Richardson, B.C., Plasiant, O., Shimamura, A.P., Reed, B.R. and Jagust, W.J. (1997). Functional neuroimaging of cortical dysfunction in alcoholic Korsakoff's syndrome. *Journal of Cognitive Neuroscience*, 9, 277–93.
- Pallis, C.A. (1955). Impaired identification of faces and places with agnosia for colours. Report of a case due to cerebral embolism. *Journal of Neurology, Neurosurgery and Psychiatry*, 18, 218–24.
- Palmer, R.E. and Corballis, M.C. (1996). Predicting readability from handedness measures. *British Journal of Psychology*, 87, 609–20.
- Pandya, D.N. and Seltzer, B. (1986). The topography of commissural fibres. In F. Lepore, M. Ptito and H.H. Jasper (eds), *Two Hemispheres – One Brain: Functions of the Corpus Callosum*. New York: Liss.
- Pantelis, C., Velakoulis, D., McGorry, P.D., Wood, S.J., Suckling, J. (2003). Neuroanatomical abnormalities before and after onset of psychosis: a cross-sectional and longitudinal MRI comparison. *The Lancet*, 361, 281–8.
- Papagno, C., Della Sala, S. and Basso, A. (1993). Ideomotor apraxia without aphasia and aphasia without apraxia: the anatomical support for a double dissociation. *Journal of Neurology, Neurosurgery and Psychiatry*, 56, 286–9.
- Papanicolaou, A.C., Eisenberg, H.M. and Levy, R.S. (1983). Evoked-potential correlates of left-hemisphere dominance in covert articulation. *International Journal of Neuroscience*, 20, 3/4, 289–93.
- Papero, P.H., Prigatano, G.P., Snyder, H.M. and Johnson, D.L. (1993). Children's adaptive behavioural competence after head injury. *Neuropsychological Rehabilitation*, 3, 4, 321–40.
- Papez, J.W. (1937). A proposed mechanism of emotion. *Archives of Neurology and Psychiatry*, 38, 725–44.
- Paquette, V., Levesque, J., Mensour, B. (2003). 'Change the mind and you change the brain': Effects of cognitive-behavioural therapy on the neural correlates of spider phobia. *Neuroimage*, 18, 401–9.
- Parente, R. and Stapleton, M. (1997). History and systems of cognitive rehabilitation. *Neurorehabilitation*, 8, 3–11.
- Park, D.C. and Kidder, D.P. (1996). Prospective memory and medication adherence. In M. Brandimonte, G.O. Einstein and M.A. McDaniel (eds), *Prospective Memory: Theory and Applications*. Mahwah, NJ: Lawrence Erlbaum.
- Park, D.C., Polk, T.A., Park, R., Minear, M., Savage, A. and Smith, M.R. (2004). Aging reduces neural specialization in ventral visual cortex. *Proceedings of the National Academy of Science of the United States of America*, 101, 35, 13091–5.
- Park, N.W., Conrod, B., Rewilak, D., Kwon, C., Gao, F. and Black, S.E. (2001). Automatic activation of positive but not negative attitudes after traumatic brain injury. *Neuropsychologia*, 39, 7–24.
- Parkin, A.J. (1997a). *Memory and Amnesia*. Hove, UK: Psychology Press.
- Parkin, A.J. (1997b). The long and winding road: twelve years of frontal amnesia. In A.J. Parkin (ed.), *Case Studies in the Neuropsychology of Memory*. Hove, UK: Psychology Press.
- Parkin, A.J. (2003). Low-velocity intra-nasal penetrating head injury: case NA. In C. Code, C.-W. Wallesch, Y. Joannette, Y. and A.R. Lecours (eds), *Classic Cases in Neuropsychology*, Vol. 2. Hove, UK: Psychology Press.
- Parkin, A.J., Bindschadler, C., Harsent, L. and Metzler, C. (1999). Pathological false alarm rates following damage to the left frontal cortex. *Brain and Cognition*, 7, 231–43.

- Parkin, A.J. and Stewart, F. (1993). Category-specific impairments? No. A critique of Sartori *et al.* *Quarterly Journal of Experimental Psychology*, 46A, 505–9.
- Parkin, A.J., Yeomans, J. and Bindschaedler, C. (1994). Further characterisation of the executive memory impairment following frontal lobe lesions. *Brain and Cognition*, 26, 23–42.
- Passingham, R.E. (1995). *The Frontal Lobes and Voluntary Action*. Oxford: Oxford University Press.
- Pascual-Leone, A., Catala, M.D. and Pascual, A. (1996). Lateralized effect of rapid-rate transcranial magnetic stimulation of the prefrontal cortex on mood. *Neurology*, 46, 499–502.
- Patterson, K.E. (1994). Reading, writing and rehabilitation: a reckoning. In M.J. Riddoch and G. Humphreys (eds), *Cognitive Neuropsychology and Cognitive Rehabilitation*. Hove, UK: Psychology Press.
- Patterson, K.E. and Marcel, A.J. (1977) Aphasia, dyslexia and the phonological coding of written words. *Quarterly Journal of Experimental Psychology*, 29, 307–18.
- Paulesu, E., Demonet, J.-F., Fazio, F., McCory, E., Chanoine, V., Brunswick, N., Cappa, S.F., Cossu, G., Habib, M., Frith, C.D. and Frith, U. (2001). Dyslexia: cultural diversity and biological unity. *Science*, 291, 2165–67.
- Paulesu, E., Frith, U., Snowling, M., Gallagher, A., Morton, J., Frackowiak, R.S.J. and Frith, C.D. (1996). Is developmental dyslexia a disconnection syndrome? Evidence from PET scanning. *Brain*, 119, 1, 143–57.
- Paulesu, E., McCrory, E., Fazio, F., Menoncello, L., Brunswick, N., Cappa, S.F., Cotelli, M., Cossu, G., Corte, F., Lorusso, M., Pesenti, S., Gallagher, A., Perani, D., Price, C., Frith, C.D. and Frith, U. (2000). A cultural effect on brain function. *Nature Neuroscience*, 3, 1, 91–6.
- Paulesu, E. and Mehler, J. (1998). Right on in sign language. *Nature*, 392, 233–4.
- Pauling, L. (1935). Oxygen equilibrium of haemoglobin and its structural interpretation. *Proceedings of the National Academy of Sciences*, 21, 186–91.
- Penfield, W. and Jasper, H. (1954) *Epilepsy and the Functional Anatomy of the Human Brain*. Boston: Little, Brown.
- Penfield, W. and Rasmussen, T. (1950) *The Cerebral Cortex of Man: A Clinical Study of Localisation of Function*. New York: Macmillan.
- Penn, D.L. and Combs, D. (2000). Modification of affect perception deficits in schizophrenia. *Schizophrenia Research*, 46, 2–3, 217–29.
- Penn, D.L., Corrigan, P.W., Bentall, R.P., Racenstein, J.M. and Newman, L. (1997). Social cognition in schizophrenia. *Psychological Bulletin*, 121, 1, 114–32.
- Perani, D., Bressi, S., Cappa, S.F., Vallar, G., Alberoni, M., Grassi, F., Caltagirone, C., Cipolotti, L., Franceschi, M., Lenzi, G.L. and Fazio, F. (1993). Evidence of multiple memory systems in the human brain. *Brain*, 116, 903–19.
- Perani, D., Colombo, C., Bressi, S. (1995). [18F]FDG PET study in obsessive–compulsive disorder. A clinical/metabolic correlation study after treatment. *British Journal of Psychiatry*, 166, 244–50.
- Perani, D., Paulesu, E., Galles, N.S., Dupoux, E., Dehaene, S., Bettinardi, V., Cappa, S.F., Fazio, F. and Mehler, J. (1998). The bilingual brain: proficiency and age of acquisition of the second language. *Brain*, 121, 1841–52.
- Perenin, M.T. and Vighetto, A. (1988). Optic ataxia: a specific disorder in visuomotor coordination. In A. Hein and M. Jeannerod (eds), *Spatially Oriented Behaviour*. New York: Springer.
- Perria, L., Rossalini, G. and Rossi, G.F. (1961). Determination of side of cerebral dominance with Amobarbital. *Archives of Neurology*, 4, 173–81.
- Perris, C., Monakhov, K., von Knorring, L., Botskarev, M. and Nikiforov, A. (1978). Systemic structural analysis of the electroencephalogram of depressed patients: general principles and preliminary results of an international collaborative study. *Neuropsychobiology*, 4, 207–20.
- Perry, D.W., Zatorre, R.J., Petrides, M., Alivisatos, B., Meyer, E. and Evans, A.C. (1999). Localization of cerebral activity during simple singing. *NeuroReport*, 10, 3453–8.
- Perry, E.K., Irving, D., Blessed, G., Fairbairn, A. and Perry, E.K. (1990). Senile dementia of Lewy body type: a clinically and neuropathologically distinct form of Lewy body dementia in the elderly. *Journal of the Neurological Sciences*, 95, 119–39.
- Perry, E.K., Tomlinson, B.E., Blessed, G., Bergmann, K., Gibson, P.H. and Perry, R.H. (1978). Correlation of cholinergic abnormalities with senile plaques and mental test scores in senile dementia. *British Medical Journal*, 2, 1457–9.
- Perry, R.J. and Hodges, J.R. (1999). Attention and executive deficits in Alzheimer's disease: a critical review. *Brain*, 122, 383–404.
- Perry, W., Feifel, D., Minassian, A., Bhattacharjje, I. and Braff, D.L. (2002). Information processing deficits in acutely psychotic schizophrenia patients medicated and unmedicated at time of admission. *American Journal of Psychiatry*, 159, 8, 1375–81.
- Peters, M. (1992). How sensitive are handedness prevalence figures to differences in handedness classification procedures? *Brain and Cognition*, 18, 208–15.
- Peters, M. (1995). Handedness and its relation to other indices of cerebral lateralization. In R.J. Davidson and K. Hugdahl (eds), *Brain Asymmetry*. Cambridge, Mass.: MIT Press.
- Petersen, S.E., Fox, P.T., Posner, M.I., Mintun, M. and Raichle, M.E. (1988). Positron emission tomographic studies of the cortical anatomy of single-word processing. *Nature*, 331, 585–9.

- Petersen, S.E., Fox, P.T., Snyder, A.Z. and Raichle, M.E. (1990) Activation of extrastriate and frontal cortical areas by visual words and word-like stimuli. *Science*, 249, 1041–4.
- Peterson, B., Riddle, M.A., Cohen, D.J., Katz, L.D., Smith, J.C., Hardin, M.T. and Leckman, J.F. (1993). Reduced basal ganglia volumes in Tourette's syndrome using three-dimensional reconstruction techniques from magnetic resonance images. *Neurology*, 43, 941–9.
- Peterson, K.M., Reis, A., Castro-Cladas, A. and Ingvar, M. (1999). Effective auditory–verbal encoding activates the left prefrontal and the medial temporal lobes: a generalization to illiterate subjects. *NeuroImage*, 10, 45–54.
- Petrie, K., Dibble, C., Long-Taylor, M. and Ruth, G. (1986). A New Zealand subtest for the WAIS-R. *New Zealand Journal of Psychology*, 15, 23–6.
- Petruzzello, S.J., Hall, E.E. and Ekkekakis, P. (2001). Regional brain activation as a biological marker of affective responsivity to acute exercise: influence of fitness. *Psychophysiology*, 38, 99–106.
- Pfeifer, R.A. (1936). Pathologie der Horstrahlung und der corticalen Horsphäre. In O. Bumke and O. Foerster (eds), *Handbuch der Neurologie*, Vol. 6. Berlin: Springer.
- Phelps, E.A., O'Connor, K.J., Gatenby, J.C., Gore, J.C., Grillon, C. and Davis, M. (2001). *Nature Neuroscience*, 4, 437–41.
- Phillips, M.L. *et al.* (1997). A specific neural substrate for perceiving facial expressions of disgust. *Nature*, 389, 495–8.
- Phillips, R.G. and LeDoux, J.E. (1994). Lesions of the dorsal hippocampal formation interfere with background but not foreground contextual fear conditioning. *Learning and Memory*, 1, 34–44.
- Pick, A. (1905). *Studien über Motorische Apraxie und ihr Nahestehende Erscheinungen*. Leipzig: Deuticke.
- Picton, T.W., Bentin, S., Berg, P., Donchin, E., Hillyard, S.A., Johnson, R., Miller, G.A., Ritter, W., Ruchkin, D.S., Rugg, M.D. and Taylor, M.J. (2000). Guidelines for using human event-related potentials to study cognition: recording standards and publication criteria. *Psychophysiology*, 37, 127–52.
- Pieczuro, A.C. and Vignolo, L.A. (1967). Studio sperimentale sulla apraxia ideomotoria. *Sistema Nervoso*, 19, 131–43.
- Pieniadz, J.M., Naeser, M.A., Kloff, E. and Levine, H.L. (1983). CT scan cerebral hemispheric asymmetry measurements in stroke cases with global aphasia: atypical asymmetries associated with improved recovery. *Cortex*, 19, 371–91.
- Piguet, O., Grayson, D.A., Tate, R.L., Bennett, H.P., Lye, T.C., Creasey, H., Brooks, W.S. and Broe, G.A. (2005). A model of executive functions in very old community dwellers: evidence from the Sydney older persons study. *Cortex*, 41, 27–37.
- Pinker, S. (1997). *How the Mind Works*. New York: W.W. Norton.
- Pinker, S. and Mehler, J. (1988). *Connections and Symbols*. Cambridge, Mass.: MIT Press.
- Pisella, L., Berberovic, N. and Mattingley, J.B. (2004). Impaired working memory for location but not for colour or shape in visual neglect: a comparison of parietal and non-parietal lesions. *Cortex*, 40, 379–90.
- Pizzamiglio, G., Antonucci, A., Judica, A., Montenero, P., Razzano, C. and Zoccolotti, P. (1992). Cognitive rehabilitation of the hemineglect disorder in chronic patients with unilateral right brain damage. *Journal of Experimental and Clinical Neuropsychology*, 14, 901–23.
- Platel, H., Price, C., Baron, J.-C., Wise, R., Lambert, J., Frackowiak, R.S.J., Lechevalier, B. and Eustache, F. (1997). The structural components of music perception: a functional anatomical study. *Brain*, 120, 229–43.
- Plaut, D.C. and McClelland, J.L. (2000). Stipulating versus discovering representations. *Behavioural Brain Sciences*, 23, 489–91.
- Plaut, D.C., McClelland, J.L., Seidenberg, M.S. and Patterson, K. (1996). Understanding normal and impaired word reading: computational principles in quasi-regular domains. *Psychological Review*, 103, 56–115.
- Plaut, D.C. and Shallice, T. (1993). Deep dyslexia: a case study of connectionist neuropsychology. *Cognitive Neuropsychology*, 10, 377–500.
- Plutchik, R. (1994). *The Psychology and Biology of Emotion*. London: HarperCollins.
- Poeck, K. (1983). Ideational apraxia. *Journal of Neurology*, 230, 1–5.
- Poeck, K. (1986). The clinical examination for motor apraxia. *Neuropsychologia*, 24, 129–34.
- Poeck, K. and Lehmkuhl, G. (1980). Das Syndrom der ideatorischen Apraxie und seine Localisation. *Nervenarzt*, 51, 217–25.
- Poizner, H. and Kegl, T.A. (1992). The neural basis of language and motor behaviour: Evidence from American Sign Language. *Aphasiology*, 6, 219–56.
- Poizner, H., Klima, E. and Bellugi, U. (1987). *What the Hands Reveal about the Brain*. Cambridge, Mass.: MIT Press.
- Poldrack, R.A., Wagner, A.D., Prull, M.W., Desmond, J.E., Glover, G.H. and Gabrieli, J.D.E. (1999). Functional specialization for semantic and phonological processing in the left inferior prefrontal cortex. *Neuroimage*, 10, 15–35.
- Polich, J. and Kok, A. (1995). Cognitive and biological determinants of P300: an integrative overview. *Biological Psychology*, 41, 103–46.

- Poline, J.-B., Vandenberghe, R., Holmes, A.P., Friston, K.J. and Frackowiak, R.S.J. (1996). Reproducibility of PET activation studies: lessons from a multi-center European experiment. *Neuroimage*, 4, 34–54.
- Poon, L.W. (1985). Differences in human memory with aging: nature, causes, and clinical implications. In J.E. Birren and K.W. Schaie (eds), *Handbook of the Psychology of Aging* (2nd edition). New York: Van Nostrand Reinhold.
- Pöppel, E., Frost, D. and Held, R. (1973). Residual visual function after brain wounds involving the central visual pathways in man. *Nature*, 243, 295–6.
- Porac, C. and Coren, S. (1981). *Lateral Preferences and Human Behaviour*. New York: Springer.
- Porteus, S.D. (1965). *The Porteus Maze Test. Fifty Years of Application*. Palo Alto, Calif: Pacific Books.
- Posner, M. (1980). Orienting of attention. The 7th Sir F.C. Bartlett Lecture. *Quarterly Journal of Experimental Psychology*, 32, 3–25.
- Posner, M. (1993). Interaction of arousal and selection in the posterior attention network. In A. Baddeley and L. Weiskrantz (eds), *Attention, Selection, Awareness and Control. A Tribute to Donald Broadbent*. Oxford: Oxford University Press.
- Posner, M. and Petersen, S.E. (1990). The attention system of the human brain. *Annual Review of Neuroscience*, 13, 25–42.
- Posner, M. and Raichle, M. (1994). *Images of Mind*. New York: Scientific American Library.
- Possl, J. and von Cramon, Y. (1996). Clients' view of neuropsychological rehabilitation. *Brain Injury*, 10, 2, 125–32.
- Praamstra, P., Hagoort, P., Maassen, B. and Crul, T. (1991). Word deafness and auditory cortical function: a case history and hypothesis. *Brain*, 114, 1197–225.
- Prabhakaran, V., Narayanan, K., Zhao, Z. and Gabrieli, J.D.E. (2000). Integration of diverse information in working memory within the frontal lobe. *Nature Neuroscience*, 3, 1, 85–90.
- Pramstaller, P.P. and Marsden, C.D. (1996). The basal ganglia and apraxia. *Brain*, 119, 319–40.
- Price, C.J. and Friston, K.J. (1997). Cognitive conjunctions: a new approach to brain activation experiments. *Neuroimage*, 5, 261–70.
- Price, C.J., Gorno-Tempini, M.L., Graham, K.S., Biggio, N., Mechelli, A., Patterson, K. and Noppeney, U. (2003). Normal and pathological reading: converging data from lesion and imaging studies. *Neuroimage*, 20, S30–S41.
- Price, C.J., Howard, D., Patterson, K., Warburton, E.A., Friston, K.J. and Frackowiak, R.S.J. (1998). A functional neuroimaging description of two deep dyslexic patients. *Journal of Cognitive Neuroscience*, 10, 303–15.
- Price, C.J., Mummery, C.J., Moore, C.J., Frackowiak, R.S.J. and Friston, K.J. (1999). Delineating necessary and sufficient neural systems with functional imaging studies of neuropsychological patients. *Journal of Cognitive Neuroscience*, 11, 4, 371–82.
- Price, C.J., Wise, R.J.S. and Frackowiak, R.S.J. (1996). Demonstrating the implicit processing of visually presented words and pseudowords. *Cerebral Cortex*, 6, 62–70.
- Price, C.J., Wise, R.J.S., Watson, J.D.G., Patterson, K., Howard, D. and Frackowiak, R.S.J. (1994). Brain activity during reading: the effects of exposure duration and task. *Brain*, 117, 1255–69.
- Procter, A.W., Palmer, A.M., Francis, P.T., Lowe, S.L., Neary, D., Murphy, E., Doshi, R. and Bowen, D.M. (1988). Evidence of glutamatergic denervation and possible abnormal metabolism in Alzheimer's disease. *Journal of Neurochemistry*, 50, 790–802.
- Provins, K.A. (1997). Handedness and speech: a critical reappraisal of the role of genetic and environmental factors in the cerebral lateralization of function. *Psychological Review*, 104, 3, 554–71.
- Prusiner, S.B. (1987). Prions and neurodegenerative diseases. *New England Journal of Medicine*, 317, 1571–81.
- Pugh, K.R., Mencl, W.E., Jenner, A.R., Katz, L., Frost, S.J., Lee, J.R., Shaywitz, S.E. and Shaywitz, B.A. (2001). Neurobiological studies of reading and reading disability. *Journal of Communication Disorders*, 34, 6, 479–92.
- Pugh, K.R., Mencl, W.E., Jenner, A.J., Katz, L., Lee, J.R., Shaywitz, S.E. and Shaywitz, B.A. (2000). Functional neuroimaging studies of reading and reading disability (developmental dyslexia). *Mental Retardation and Developmental Disabilities Review*, 6, 3, 207–13.
- Pugh, K.R., Shaywitz, B.A., Shaywitz, S.E., Constable, R.T., Skudlarski, P., Fulbright, R.K., Bronen, R.A., Shankweiler, D.P., Katz, L., Fletcher, J. and Gore, J.C. (1996). Cerebral organisation of component processes in reading. *Brain*, 119, 1221–38.
- Quik, M. (2004). Smoking, nicotine and Parkinson's disease. *Trends in Neurosciences*, 27, 9, 561–8.
- Quik, M. and Kulak, J.M. (2002). Nicotine and nicotinic receptors: relevance to Parkinson's disease. *Neurotoxicology*, 23, 581–94.
- Rabbitt, P. (1993). Does it all go together when it goes? The nineteenth Bartlett Memorial Lecture. *Quarterly Journal of Experimental Psychology*, 46A, 3, 385–434.
- Rabbitt, P., Maylor, E., McInnes, L., Bent, N. and Moore, B. (1995). What goods can self-assessment questionnaires deliver for cognitive gerontology? *Applied Cognitive Psychology*, 9, S127–S152.
- Rademacher, J., Galaburda, A.M., Kennedy, D.N., Filipek, P.A. and Caviness, V.S. (1993). Topographic variation

- of the human primary cortices: implications for neuroimaging, brain mapping and neurobiology. *Cerebral Cortex*, 3, 313–29.
- Rae, C., Harasty, J.A., Dzendrowskyj, T.E., Talcott, J.B., Simpson, J.M., Blamire, A.M., Dixon, R.M., Lee, M.A., Thompson, C.H., Styles, P., Richardson, A.J. and Stein, J.F. (2002). Cerebellar morphology in developmental dyslexia. *Neuropsychologia*, 46, 1285–92.
- Raichle, M.E. (1994). Images of the mind: studies with modern imaging techniques. *Annual Review of Psychology*, 45, 333–56.
- Raine, A. (1993). *The Psychopathology of Crime*. New York: Academic Press.
- Raine, A., Lencz, T., Bihrl, S., Lacasse, L. and Collenti, P. (2000). Reduced prefrontal gray matter volume and reduced autonomic activity in anti-social personality disorder. *Archives of General Psychiatry*, 57, 119–27.
- Rajput, A.H., Offort, K., Beard, C.M. and Kurland, L.T. (1984). Epidemiological survey of dementia in Parkinsonism and control population. In R.G. Hassler and J.F. Christ (eds), *Advances in Neurology*, Vol. 40. New York: Raven Press.
- Ramsay, D.S. (1980). Beginnings of bimanual handedness and speech in infants. *Infant Behaviour and Development*, 3, 67–77.
- Ramus, F. (2003). Developmental dyslexia: specific phonological deficit or general sensorimotor dysfunction? *Current Opinion in Neurobiology*, 13, 212–18.
- Ramus, F. (2004). Neurobiology of dyslexia: a reinterpretation of the data. *Trends in Neurosciences*, 27, 12, 720–6.
- Ramus, F. *et al.* (2003). Theories of developmental dyslexia: insights from a multiple case study of dyslexic adults. *Brain*, 126, 841–65.
- Randt, C.T. and Brown, E.R. (1986). *Randt Memory Test*. Bayport: Life Science Associates.
- Rao, S.M. (1986). Neuropsychology of multiple sclerosis: a critical review. *Journal of Clinical and Experimental Neuropsychology*, 8, 503.
- Rasmussen, T. and Milner, B. (1975). Clinical and surgical studies of the cerebral speech areas in man. In K.J. Zulch, O. Creutzfeldt and G.C. Galbraith (eds), *Cerebral Localization*. New York: Springer.
- Rasmussen, T. and Milner, B. (1977). The role of early left brain injury in determining lateralization of cerebral speech functions. *Annals of the New York Academy of Sciences*, 299, 355–69.
- Rauch, S.L., Jenike, M.A. and Alpert, N.M. (1994). Regional cerebral blood flow measured during symptom provocation in obsessive-compulsive disorder using oxygen 15-labeled carbon dioxide and positron emission tomography. *Archives of General Psychiatry*, 51, 62–70.
- Rauch, S.L., Savage, C.R. and Alpert, N.M. (1995). A positron emission tomographic study of simple phobic symptom provocation. *Archives of General Psychiatry*, 52, 20–8.
- Rauch, S.L., Savage, C.R. and Alpert, N.M. (1997). Probing striatal function in obsessive-compulsive disorder: A PET study of implicit sequence learning. *Journal of Neuropsychiatry and Clinical Neuroscience*, 9, 568–73.
- Rauch, S.L., Shin, L.M., Whalen, P.J. and Pitman, R.K. (1998). Neuroimaging and the neuroanatomy of PTSD. *CNS Spectrums*, 3, suppl. 2, 30–41.
- Rauch, S.L., van der Kolk, B.A. and Fisler, R.E. (1996). A symptom provocation study of posttraumatic stress disorder using positron emission tomography and script-driven imagery. *Archives of General Psychiatry*, 53, 380–7.
- Rauch, S.L., Whalen, P.J., Dougherty, D.D. and Jenike, M.A. (1996). Cerebral structural abnormalities in obsessive-compulsive disorder. A quantitative morphometric magnetic resonance imaging study. *Archives of General Psychiatry*, 53, 625–32.
- Rawlinson, J.N., Russell, T., Coakham, H.B. and Byrnes, D.P. (1988). Trans-nasal hypophysectomy: an unusual sporting injury. *Surgical Neurology*, 30, 311–15.
- Ray, W.J. and Cole, H. (1985). EEG alpha activity reflects attentional demands and beta activity reflects emotional and cognitive processes. *Science*, 228, 750–2.
- Redish, A.D. and Touretzky, D.S. (1997). Cognitive maps beyond the hippocampus. *Hippocampus*, 7, 15–35.
- Reed, C.L., Caselli, R.J. and Farah, M.J. (1996). Tactile agnosia. *Brain*, 119, 875–88.
- Reed, L.J., Lasserson, D., Marsden, P., Stanhope, N., Stevens, T., Bello, F., Kingsley, D., Colchester, A. and Kopelman, M.D. (2003). FDG-PET findings in the Wernicke-Korsakoff syndrome. *Cortex*, 39, 1027–45.
- Rees, G., Frackowiak, R. and Frith, C. (1997). Two modulatory effects of attention that mediate object categorization in human cortex. *Science*, 275, 5301, 835–8.
- Reiman, E.M., Raichle, M.E., Robins, E., Butler, F.K., Herscoritch, P., Fox, P.T. and Perlmutter, J. (1986). The application of positron emission tomography to the study of panic disorder. *American Journal of Psychiatry*, 143, 469–77.
- Reiman, E.M. *et al.* (2004). Functional brain abnormalities in young adults at genetic risk for late-onset Alzheimer's dementia. *Proceedings of the National Academy of Sciences*, 101, 284–9.
- Reiss, A.L., Abrams, M.T., Singer, H.S., Ross, J.L. and Denckla, M.B. (1996). Brain development, gender and IQ in children. *Brain*, 119, 1763–74.
- Reitan, R.M. (1955). Investigation of the validity of Halstead's measures of biological intelligence. *Archives of Neurology and Psychiatry*, 73, 28–35.

- Reitan, R.M. and Wolfson, D. (1990). A consideration of the comparability of the WAIS and WAIS-R. *The Clinical Neuropsychologist*, 4, 80–5.
- Reitan, R.M. and Wolfson, D. (1993). *The Halstead–Reitan Neuropsychological Test Battery: Theory and Clinical Applications* (2nd edition). Tucson: Neuropsychology Press.
- Renner, M. and Rosenzweig, M.R. (1987). *Enriched and Impoverished Environments: Effects on Brain and Behaviour*. New York: Springer.
- Resch, E., Haffner, J., Parzer, P., Pfueller, U., Strehlow, U. and Zerahn-Hartung, C. (1997). Testing the hypothesis of the relationships between laterality and ability according to Annett's right-shift theory: findings in an epidemiological sample of young adults. *British Journal of Psychology*, 88, 621–36.
- Resnick, S.M., Lazar, J., Gur, R.E. and Gur, R.C. (1994). The stability of tachistoscopic measures of hemispheric specialization. *Neuropsychologia*, 32, 11, 1419–30.
- Reuter-Lorenz, P.A., Jonides, J., Smith, E.E., Hartley, A., Miller, A., Marshuetz, C. and Koeppel, R.A. (2000). *Journal of Cognitive Neuroscience*, 12, 174–87.
- Rey, A. (1941). L'examen psychologique dans les cas d'encephalopathie traumatique. *Archives of Psychology*, 28, 286–340.
- Rey, A. (1964). *L'Examen clinique en psychologie*. Paris: Presses Univ. France.
- Rezai, K., Andreasen, N.C., Alliger, R., Cohen, G., Swayze, V. and O'Leary, D.S. (1993). The neuropsychology of the prefrontal cortex. *Archives of Neurology*, 50, 22, 636–42.
- Rhodes, G., Byatt, G., Michie, P.T. and Puce, A. (2004). Is the fusiform face area specialised for faces, individuation, or expert individuation? *Journal of Cognitive Neuroscience*, 16, 2, 189–203.
- Riddoch, G. (1917). Dissociation of visual perceptions due to occipital injuries, with special reference to appreciation of movement. *Brain*, 40, 15–47.
- Riddoch, M.J. and Humphreys, G.W. (1983). The effect of cueing on unilateral neglect. *Neuropsychologia*, 21, 589–99.
- Riddoch, M.J., Humphreys, G.W., Coltheart, M. and Funnell, E. (1988). Semantic systems or system? Neuropsychological evidence examined. *Cognitive Neuropsychology*, 5, 3–25.
- Riley, G.A. and Simmonds, L.V. (2003). How robust is performance on the National Adult Reading test following traumatic brain injury? *British Journal of Clinical Psychology*, 42, 319–28.
- Riley, K.P. et al. (2000). Cognitive function and alipoprotein E in very old adults: findings from the Nun Study. *Journal of Gerontology*, 55, 69–75.
- Rinn, W.E. (1984). The neuropsychology of facial expression: a review of the neurological and psychological mechanisms for producing facial expression. *Psychological Bulletin*, 95, 1, 52–77.
- Rippon, G. and Brunswick, N. (1998). EEG correlates of phonological processing in dyslexic children. *Journal of Psychophysiology*, 12, 3, 261–74.
- Rippon, G. and Brunswick, N. (2000). State and trait EEG indices of information processing in developmental dyslexia. *International Journal of Psychophysiology*, 36, 3, 251–65.
- Risse, G.L., Gates, J., Lund, G., Maxwell, R. and Rubens, A. (1989). Interhemispheric transfer in patients with incomplete section of the corpus callosum: anatomic verification with magnetic resonance imaging. *Archives of Neurology*, 46, 437–43.
- Ritchie, K. (1997). Establishing the limits of normal cerebral aging and senile dementia. *British Journal of Psychiatry*, 173, 97–101.
- Ritchie, K., Leibovici, D., Ledesert, B. et al. (1996). A typology of sub-clinical senescent cognitive disorder. *British Journal of Psychiatry*, 168, 470–6.
- Riva, D. and Cazzamiga, L. (1986). Late effects of unilateral brain lesions before and after the first year of age. *Neuropsychologia*, 24, 423–8.
- Rizolatti, G., Umiltà, C. and Berlucchi, G. (1971). Opposite superiorities of the right and left cerebral hemispheres in discriminative reaction time to physiological and alphabetic material. *Brain*, 94, 431–42.
- Robbins, T.W., Mehta, M.A. and Sahakian, B.J. (2000). Boosting working memory. *Science*, 290, 2275–6.
- Robbins, T.W. and Sahakian, B.J. (1994). Computer methods of assessment of cognitive function. In J.R.M. Copeland, M.T. Abou-Saleh and D.G. Blazer (eds), *Principles and Practice of Geriatric Practice*. Chichester, UK: John Wiley & Sons.
- Robertson, D.A., Gernsbacher, M.A., Guidotti, S., Robertson, R. and Irwin, W. (2000). Functional neuroanatomy of the cognitive process of mapping during discourse comprehension. *Psychological Science*, 11, 255–60.
- Robertson, I.H. (1990). Does computerised cognitive rehabilitation work? A review. *Aphasiology*, 4, 381–405.
- Robertson, I.H., Halligan, P.W. and Marshall, J.C. (1993). Prospects for the rehabilitation of unilateral neglect. In I.H. Robertson and J.C. Marshall (eds), *Unilateral Neglect: Clinical and Experimental Studies*. Hove, UK: Lawrence Erlbaum.
- Robertson, I.H., Ward, T. and Nimmo-Smith, I. (1994). *The Test of Everyday Attention*. Bury St Edmunds: Thames Valley Test Company.
- Robertson, I.H., Ward, T. and Nimmo-Smith, I. (1996). The structure of normal human attention: the Test of Everyday Attention. *Journal of the International Neuropsychological Society*, 2, 525–34.
- Robertson, L.C. and Lamb, M.R. (1991). Neuropsychological contributions to theories of part/whole organisation. *Cognitive Psychology*, 23, 299–330.

- Robinson, R.G. and Benson, D.F. (1981). Depression in aphasic patients: frequency, severity, and clinical pathological correlation. *Brain and Language*, 14, 282–91.
- Rocca, W.A., Amaducci, L.A. and Schoenberg, B.S. (1986). Epidemiology of clinically diagnosed Alzheimer's disease. *Annals of Neurology*, 19, 415–24.
- Rockland, K.S. and Pandya, D.N. (1986). Topography of occipital lobe commissural connections in the rhesus monkey. *Brain Research*, 365, 174–8.
- Rodriguez-Oroz, M.C., Obeso, J.A., Lang, A.E. *et al.* (2005). Bilateral deep brain stimulation in Parkinson's disease: A multicentre study with 4 years follow-up. *Brain*, 128, 2240–9.
- Rogers, T.T., Hocking, J., Mechelli, A., Patterson, K. and Price, C. (2005). Fusiform activation to animals is driven by the process, not the stimulus. *Journal of Cognitive Neuroscience*, 17, 3, 434–45.
- Roid, G.H. (2003). *Stanford–Binet Intelligence Scale* (5th edition). Itasca: Riverside.
- Roland, P.E. and Friberg, L. (1985). Localization of cortical areas activated by thinking. *Journal of Neurophysiology*, 53, 1219–43.
- Roland, P.E., Larsen, B., Lassen, N.A. and Skinhoj, E. (1980) Supplementary motor area and other cortical areas in organization of voluntary movements in man. *Journal of Neurophysiology*, 43, 118–36.
- Rolls, E.T. (1984). Neurons in the cortex of the temporal lobe and in the amygdala of the monkey with responses selective for faces. *Human Neurobiology*, 3, 209–22.
- Rolls, E.T. (1989). Information processing in the taste system of primates. *Journal of Experimental Biology*, 146, 141–64.
- Rolls, E.T. (1990). A theory of emotion, and its application to understanding the neural basis of emotion. *Cognition and Emotion*, 4, 3, 161–90.
- Rolls, E.T. (1995). A theory of emotion and consciousness and its application to understanding the neural basis of emotion. In M.S. Gazzaniga (ed.), *The Cognitive Neurosciences*. Cambridge, Mass.: MIT Press.
- Rolls, E.T. (1999). *The Brain and Emotion*. New York: Oxford University Press.
- Rolls, E.T. and Baylis, L.L. (1994). Gustatory, olfactory, and visual convergence within the primate orbitofrontal cortex. *Journal of Neuroscience*, 15, 5437–52.
- Rolls, E.T., Kringelbach, M.L. and de Araujo, I.E.T. (2003). Different representations of pleasant and unpleasant odours in the human brain. *European Journal of Neuroscience*, 18, 695–703.
- Rolls, E.T., Sienkiewicz, Z.J. and Yaxley, S. (1989). Hunger modulates the responses to gustatory stimuli of single neurons in the orbitofrontal cortex. *European Journal of Neuroscience*, 1, 53–60.
- Rose, S.P.R. (1992). *The Making of Memory*. New York: Bantam.
- Rosenbaum, R.S., Gao, F., Richards, B., Black, S.E. and Moscovitch, M. (2005). 'Where to?' Remote memory for spatial relations and landmark identity in former taxi drivers with Alzheimer's disease and encephalitis. *Journal of Cognitive Neuroscience*, 17, 3, 446–62.
- Rosenbaum, R. S., McKinnon, M. C., Levine, B. and Moscovitch, M. (2004). Visual imagery deficits, impaired strategic retrieval, or memory loss: disentangling the nature of an amnesic person's autobiographical memory deficit. *Neuropsychologia*, 42, 1619–35.
- Rosenberger, P.B. (1990) Morphological cerebral asymmetries and dyslexia. In G.T. Pavlidis (ed.), *Perspectives on Dyslexia*, Vol. 1. Chichester, UK: John Wiley & Sons.
- Rosenzweig, M.R., Krech, D. and Bennett, E.L. (1961). Heredity, environment, brain biochemistry and learning. In *Current Trends in Psychological Theory*. Pittsburgh: University of Pittsburgh Press.
- Rosenzweig, M.R., Krech, D., Bennett, E.L. and Diamond, M.C. (1962). Effects of environmental complexity and training on brain chemistry and anatomy: a replication and extension. *Journal of Comparative and Physiological Psychology*, 55, 429–37.
- Ross, E.D. (1981). The aprosodias. *Archives of Neurology*, 38, 561–9.
- Ross, E.D. (1985). Modulation of affect and nonverbal communication by the right hemisphere. In M.-M. Mesulam (ed.), *Principles of Behavioural Neurology*. Philadelphia: Davis.
- Rossetti, Y., Rode, G., Pisella, L., Farnè, A., Li, L., Boisson, D. and Perenin, M.T. (1998). Prism adaptation to a rightward optical deviation rehabilitates left hemispatial neglect. *Nature*, 395, 166–9.
- Roth, M. (1986). The association of clinical and neurological findings and its bearing on the classification and aetiology of Alzheimer's disease. *British Medical Bulletin*, 42, 42–50.
- Rothi, L.J.G., Raymer, A.M. and Heilman, K.M. (1997). Limb praxis assessment. In L.J.G. Rothi and K.M. Heilman (eds), *Apraxia: The Neuropsychology of Action*. Hove, UK: Psychology Press.
- Rourke, B.P., Bakker, D.J., Fisk, J.L. and Strang, J.D. (1983). *Child Neuropsychology: An Introduction to Theory, Research and Clinical Practice*. New York: Guilford Press.
- Rourke, B.P., Fisk, J.L. and Strang, J.D. (1986). *Neuropsychological Assessment of Children: A Treatment Oriented Approach*. New York: Guilford Press.
- Rowe, A.D., Bullock, P.R., Polkey, C.E. and Morris, R.G. (2001). 'Theory of mind' impairments and their relationship to executive functioning following frontal lobe excisions. *Brain*, 124, 600–16.
- Rubens, A. (1985). Caloric stimulation and unilateral visual neglect. *Neurology*, 35, 1019–24.
- Rubens, A.B. and Benson, D.F. (1971). Associative visual agnosia. *Archives of Neurology*, 24, 305–16.
- Ruby, P. and Decety, J. (2004). How would you feel versus how do you think she would feel? A neuroimaging study of perspective-taking with social emotions. *Journal of Cognitive Neuroscience*, 16, 6, 988–99.

- Rudge, P. and Warrington, E.K. (1990). Selective impairment of memory and visual perception in splenial tumours. *Brain*, 113.
- Rumelhart, D.E. and McClelland, J.L. (1986). *Parallel Distributed Processing*. Cambridge, Mass.: MIT Press.
- Rumsey, J.M., Andreason, P., Zametkin, A.J., Aquino, T., King, A., Hamburger, S., Pileus, A., Rapoport, J. and Cohen, R. (1992). Failure to activate the left temporoparietal cortex in dyslexia. An oxygen 15 positron emission tomographic study. *Archives of Neurology*, 49, 527–34.
- Rumsey, J.M., Nace, K., Donohue, B., Wise, D., Maisog, M. and Andreason, P.A. (1997). A positron emission tomographic study of impaired word recognition and phonological processing in dyslexic men. *Archives of Neurology*, 54, 562–73.
- Runyan, J.D., Moore, A.N. and Dash, P.K. (2004). A role for prefrontal cortex in memory storage for trace fear conditioning. *Journal of Neuroscience*, 24, 6, 1288–95.
- Rüsseler, J., Johannes, S., Kowalczyk, J., Wieringa, B.M. and Münte, T.F. (2003). Developmental dyslexics show altered allocation of attention in visual classification tasks. *Acta Neurologica Scandinavica*, 107, 1, 22–30.
- Russell, E.W. (1982). Theory and developments of pattern analysis methods related to the Halstead–Reitan Battery. In P.E. Logue and J.M. Shear (eds), *Clinical Neuropsychology: A Multidisciplinary Approach*. Chicago: Charles C. Thomas.
- Russell, E.W. and Starkey, R.I. (1993). *Halstead Russell Neuropsychological Evaluation System (HRNES)*. Los Angeles: Western Psychological Services.
- Russell, J.A. (1994). Is there universal recognition of emotion from facial expression? A review of cross-cultural studies. *Psychological Bulletin*, 115, 102–41.
- Russo, M. and Vignolo, L.A. (1967). Visual figure–ground discrimination in patients with unilateral cerebral disease. *Cortex*, 3, 113–27.
- Ryan, C. and Butters, N. (1980). Further evidence for a continuum-of-impairment encompassing male alcoholic Korsakoff patients and chronic alcoholic men. *Alcoholism: Clinical and Experimental Research*, 4, 190–8.
- Ryan, J.J., Arb, J.D. and Kreiner, D.S. (2000). Reliability of the WAIS-III subtests, indexes, and IQs in individuals with substance abuse disorders. *Assessment*, 7, 151–6.
- Rylander, G. (1939). Personality changes after operations on the frontal lobes: clinical study of 32 cases. *Acta Psychiatrica et Neurologica Scandinavica* supplement, 20, 1–81.
- Rylander, G. (1943). Mental changes after excision of cerebral tissue. *Acta Psychiatrica et Neurologica Scandinavica* supplement, 25, 1–81.
- Sackheim, H.A., Greenberg, M.S., Weiman, A.L., Gur, R.C., Hungerbuhler, J.P. and Geschwind, N. (1982). Hemispheric asymmetry in the expression of positive and negative emotions: neurologic evidence. *Archives of Neurology*, 39, 210–18.
- Sacks, O. (1985). *The Man who Mistook his Wife for a Hat*. New York: Summit.
- Sacks, O. (1995). *An Anthropologist on Mars*. New York: Alfred A. Knopf.
- Saffran, E.M. and Marin, O.S.M. (1977). Reading without phonology: evidence from aphasia. *Quarterly Journal of Experimental Psychology*, 29, 515–25.
- Sahakian, B.J. and Owen, A.M. (1992). Computerised assessment in neuropsychiatry using CANTAB. *Journal of the Royal Society of Medicine*, 85, 399–402.
- Salame, P. and Baddeley, A.D. (1982). Disruption of short-term memory by unattended speech: implications for the structure of working memory. *Journal of Verbal Learning and Verbal Behavior*, 21, 150–164.
- Salmelin, R., Service, E., Kiesilä, P., Uutela, K. and Salonen, O. (1996). Impaired visual word processing in dyslexia revealed with magnetoencephalography. *Annals of Neurology*, 40, 157–62.
- Salmon, D.P., Butters, N. and Heindel, W.C. (1993). Alcoholic dementia and related disorders. In R.W. Parks, R.F. Zec and R.S. Wilson (eds), *Neuropsychology of Alzheimer's Disease and Other Dementias*. Oxford: Oxford University Press.
- Salmon, D.P., Galasko, D., Hansen, L.A., Masliah, E., Butters, N., Thal, L.J. and Katzman, R. (1996). Neuropsychological deficits associated with diffuse Lewy body disease. *Brain and Cognition*, 31, 148–65.
- Salmon, E., Van de Linden, M., Collette, F., Delfiore, G., Maquet, P., Degueldre, C., Luxen, A. and Franck, G. (1996). Regional brain activity during working memory tasks. *Brain*, 119, 1617–25.
- Salthouse, T.A. (1992). What do adult age differences in the Digit Symbol Substitution Test reflect? *Journal of Gerontology*, 47, 3, 121–8.
- Salthouse, T.A. (1993). Speed mediation of adult age differences in cognition. *Developmental Psychology*, 29, 4, 722–38.
- Salthouse, T.A. (1996). The processing speed theory of adult age differences in cognition. *Psychological Review*, 103, 403–28.
- Salthouse, T.A. and Babcock, R.L. (1991). Decomposing adult age differences in working memory. *Developmental Psychology*, 27, 5, 763–76.
- Sanacora, G., Mason, G., Rothman, D., Fahmeed, H., Ciarcia, J., Ostroff, R., Berman, R., and Krystal, J. (2002). Increased occipital cortex GABA concentrations in depressed patients after therapy with selective serotonin reuptake inhibitors. *American Journal of Psychiatry*, 159, 663–5.

- Sanacora, G. *et al.* (2004). Subtype-specific alterations of gamma-aminobutyric acid and glutamate in patients with major depression. *Archives of General Psychiatry*, 61, 705–13.
- Sanchez-Prieto, R.A., Pascual-Leone, A. *et al.* (2001). Grammatical distinctions in the left frontal cortex. *Journal of Neuroscience*, 13, 6, 713–20.
- Sanders, M.D., Warrington, E.K., Marshall, J. and Weiskrantz, L. (1974). 'Blindsight': vision in a field defect. *The Lancet*, 1, 707–8.
- Sasanuma, S. (1975). Kana and kanji processing in Japanese aphasics. *Brain and Language*, 2, 369–83.
- Satz, P. and Sparrow, S.S. (1970). Specific developmental dyslexia: a theoretical formulation. In D.J. Bakker and P. Satz (eds), *Specific Reading Disability: Advances in Theory and Method*. Rotterdam: Rotterdam University Press.
- Saxby, L. and Bryden, M.P. (1984). Left ear superiority in children for processing auditory emotional material. *Developmental Psychology*, 20, 72–80.
- Saykin, A.J., Wishart, H.A., Rabin, L.A., Flashman, L.A., McHugh, T.I., Mamourian, A.C. and Santulli, R.B. (2004). Cholinergic enhancement of frontal lobe activity in mild cognitive impairment. *Brain*, 127, 1574–83.
- Schacter, D.L. (1987). Implicit memory: history and current status. *Journal of Experimental Psychology: Learning, Memory and Cognition*, 13, 501–18.
- Schaefer, S.M., Jackson, D.C., Davidson, R.J., Kimberg, D.Y., and Thompson-Schill, S.L. (2002). Modulation of amygdalar activity by the conscious regulation of negative emotion. *Journal of Cognitive Neuroscience*, 14, 913–21.
- Schaffer, C.E., Davidson, R.J. and Saron, C. (1983). Frontal and parietal electroencephalographic asymmetry in depressed and non-depressed subjects. *Biological Psychiatry*, 18, 753–62.
- Schaie, K.W. (1990). Intellectual development in adulthood. In J.E. Birren and K.W. Schaie (eds), *Handbook of the Psychology of Aging* (3rd edition). San Diego: Academic Press.
- Schalling, D. and Rosen, A.S. (1968). Porteus maze differences between psychopathic and non-psychopathic criminals. *British Journal of Social and Clinical Psychology*, 7, 224–8.
- Schelleberg, D., Besthorn, C., Pflieger, W. and Gasser, T. (1993). Emotional activation and topographic EEG band power. *Journal of Psychophysiology*, 24–33.
- Schenk, D., Barber, R., Dunn, W. *et al.* (1999). Immunisation with B amyloid attenuates Alzheimer disease like pathology in the PDAPP mouse. *Nature*, 400, 173–7.
- Schienze, A., Schafer, A., Stark, R., Walter, B. and Vaitl, D. (2005). Relationship between disgust sensitivity, trait anxiety and brain activity during disgust induction. *Neuropsychobiology*, 51, 86–92.
- Schlaug, G., Jancke, L., Huang, Y. and Steinmetz, H. (1995). In vivo evidence of structural brain asymmetry in musicians. *Science*, 267, 699–701.
- Schlesinger, H. (1988). Questions and answers in the development of deaf children. In M. Strong (ed.), *Language Learning and Deafness*. Cambridge: Cambridge University Press.
- Schmajuk, N.A. (2001). Hippocampal dysfunction in schizophrenia. *Hippocampus*, 11, 5, 599–613.
- Schmidt, L.A. (1999). Frontal brain electrical activity in shyness and sociability. *Psychological Science*, 10, 4, 316–20.
- Schmidt, L.A. and Trainor, L.J. (2001). Frontal brain electrical activity (EEG) distinguishes valence and intensity of musical emotions. *Cognition and Emotion*, 15, 487–500.
- Schmitt, J.J., Hartje, W. and Willmes, K. (1997). Hemispheric asymmetry in the recognition of emotional attitude conveyed by facial expression, prosody and propositional speech. *Cortex*, 33, 65–81.
- Schneider, F., Weiss, U., Kessler, C. (2000). Subcortical correlates of differential classical conditioning of aversive emotional reactions in social phobia. *Biological Psychiatry*, 45, 863–71.
- Schneider, G.E. (1969). Two visual systems. *Science*, 163, 895–902.
- Schneider, J.S. *et al.* (1998). Effects of SIB-1508Y, a novel neuronal nicotinic acetylcholine receptor agonist, on motor behavior in parkinsonian monkeys. *Movement Disorders*, 13, 637–42.
- Schomer, D.L. (1983). Partial epilepsy. *New England Journal of Medicine*, 309, 536–9.
- Schonell, F. (1942). *Backwardness in the Basic Subjects*. London: Oliver and Boyd.
- Schou, M. (1989). Lithium prophylaxis: myths and realities. *American Journal of Psychiatry*, 146, 573–6.
- Schwartz, J.M., Stoessel, P.W., Baxter, L.R., Martin, K.M. and Phelps, M.E. (1996). Systematic changes in cerebral glucose metabolic rate after successful behaviour modification treatment of obsessive-compulsive disorder. *Archives of General Psychiatry*, 53, 109–13.
- Schwartz, M. and Chawluck, J. (1990). Deterioration of language in progressive aphasia: a case study. In M. Schwartz (ed.), *Modular Deficits in Alzheimer-type Dementia*. Cambridge, Mass.: MIT Press.
- Schwartz, M., Creasey, H., Grady, C.L., DeLeo, L.M., Frederickson, H.A. and Cutler, N.R. (1985). Computed tomographic analysis of brain morphometrics in 30 healthy men, aged 21 to 81 years. *Annals of Neurology*, 17, 146–57.
- Schwartz, S., Gramling, S., Kerr, K. and Morin, C. (1998). Evaluation of intellect and deficit-specific information

- on the ability to fake memory deficits. *International Journal of Law and Psychiatry*, 21, 3, 261–72.
- Schweinberger, S.R. and Burton, A.M. (2003). Covert recognition and the neural system for face processing. *Cortex*, 39, 9–30.
- Scoville, W.B. and Milner, B. (1957). Loss of recent memory after bilateral hippocampal lesions. *Journal of Neurology, Neurosurgery and Psychiatry*, 20, 150–76.
- Searleman, A. (1977). A review of right hemisphere linguistic abilities. *Psychological Bulletin*, 84, 503–28.
- Searleman, A., Herrmann, D.J. and Coventry, A.K. (1984). Cognitive abilities and left handedness: an interaction between familial sinistrality and strength of handedness. *Intelligence*, 8, 295–304.
- Seeck, M., Mainwaring, N., Ives, J., Blume, H., Dubuisson, D. and Cosgrove, R. (1993). Differential neural activity in the human temporal lobe evoked by faces of family members and friends. *Annals of Neurology*, 34, 369–72.
- Seeman, P. and Niznik, H.B. (1990). Dopamine receptors and transporters in Parkinson's disease and schizophrenia. *FASEB Journal*, 4, 2737–44.
- Segalowitz, S.J. and Berge, B.E. (1995). Functional asymmetries in infancy and early childhood: a review of electrophysiologic studies and their implications. In R.J. Davidson and K. Hugdahl (eds), *Brain Asymmetry*. Cambridge, Mass.: MIT Press.
- Segalowitz, S.J. and Bryden, M.P. (1983). Individual differences in hemispheric representation of language. In S.J. Segalowitz (ed.), *Language Functions and Brain Organisation*. New York: Academic Press.
- Segalowitz, S.J., Wagner, W.J. and Menna, R. (1992). Lateral versus frontal predictors of reading skill. *Brain and Cognition*, 20, 85–103.
- Seidenberg, M., Hermann, B., Wyler, A.R., Davies, K., Dohan, F.C. and Leveroni, C. (1998). Neuropsychological outcome following anterior temporal lobectomy in patients with and without the syndrome of mesial temporal lobe epilepsy. *Neuropsychology*, 12, 303–16.
- Selemon, L.D., Rajkowska, G. and Goldman-Rakic, P.S. (1995). Abnormally high neuronal density in the schizophrenic cortex. A morphometric analysis of prefrontal area 9 and occipital area 17. *Archives of General Psychiatry*, 52, 805–18.
- Selnes, O.A., Knopmann, D.S., Niccum, N., Rubens, A.B. and Larson, D. (1983). Computed tomographic scan correlates of auditory comprehension deficits in aphasia: a prospective recovery study. *Annals of Neurology*, 13, 558–66.
- Serby, M.J., Larson, P.M. and Kalkstein, D. (1992). Olfaction and neuropsychiatry. In M.J. Serby and K.L. Chobor (eds), *Science of Olfaction*. New York: Springer.
- Sergent, J. (1987). A new look at the human split brain. *Brain*, 110, 1375–92.
- Sergent, J. (1990). Furtive incursions into bicameral minds: integrative and coordinating role of subcortical structures. *Brain*, 113, 537–68.
- Sergent, J. (1991). Processing of spatial relations within and between the disconnected cerebral hemispheres. *Brain*, 114, 1025–43.
- Seymour, P.H.K. (1986). *Cognitive Analysis of Dyslexia*. London: Routledge & Kegan Paul.
- Seymour, P.H.K. and MacGregor, C.J. (1984). Developmental dyslexia: a cognitive experimental analysis of phonological, morphemic and visual impairments. *Cognitive Neuropsychology*, 1, 1, 43–82.
- Seymour, S.E., Reuter-Lorenz, P.A. and Gazzaniga, M.S. (1994). The disconnection syndrome: basic findings reaffirmed. *Brain*, 117, 105–15.
- Shaffer, L.H. (1975). Multiple attention in continuous verbal tasks. In S. Dornic (ed.), *Attention and Performance*, Vol. 5. New York: Academic Press.
- Shallice, T. (1981). Phonological agraphia and the lexical route in writing. *Brain*, 104, 413–29.
- Shallice, T. (1982). Specific impairments of planning. *Philosophical Transactions of the Royal Society*, London, 298, 199–209.
- Shallice, T. (1988). *From Neuropsychology to Mental Structure*. Cambridge: Cambridge University Press.
- Shallice, T. and Burgess, P.W. (1991). Deficits in strategy application following frontal lobe damage in man. *Brain*, 114, 727–41.
- Shallice, T., Burgess, P.W., Baxter, D.M. and Schon, F. (1989). The origins of utilisation behaviour. *Brain*, 112, 1587–98.
- Shallice, T. and Butterworth, B. (1977). Short-term memory impairment and spontaneous speech. *Neuropsychologia*, 15, 729–35.
- Shammi, P. and Stuss, D.T. (1999). Humor appreciation: a role of the right frontal lobe. *Brain*, 127, 657–66.
- Shapiro, J., Budo, D.C., Herrero, I., Vasquez, E. and Nicholls, D.G. (1996). Presynaptic receptors and the control of glutamate exocytosis. *Trends in Neurosciences*, 19, 235–39.
- Shaywitz, B.A., Shaywitz, S.E., Pugh, K.R., Constable, R.T., Skudlarski, P., Fulbright, R.K., Bronen, R.A., Fletcher, J.M., Shankweiler, D.P., Katz, L. and Gore, J.C. (1995). Sex differences in the functional organisation of the brain for language. *Nature*, 373, 607–9.
- Shaywitz, B.A., Shaywitz, S.E., Pugh, K.R., Mencl, W.E., Fulbright, R.K., Skudlarski, P., Constable, R.T., Marchione, K.E., Fletcher, J.M., Lyon, G.R. and Gore, J.C. (2002). Disruption of posterior brain systems for reading in children with developmental dyslexia. *Biological Psychiatry*, 52, 2, 101–10.
- Shaywitz, S.E., Shaywitz, B.A., Pugh, K.R., Fulbright, R.K., Constable, R.T., Mencl, W.E., Shankweiler, D.P.,

- Liberman, A.M., Skudlarski, P., Fletcher, J.M., Katz, L., Marchione, K.E., Lacadie, C., Gatenby, C. and Gore, J.C. (1998). Functional disruption in the organization of the brain for reading in dyslexia. *Proceedings of the National Academy of Sciences of the United States of America*, 95, 2636–41.
- Shepard, R.N. and Metzler, D. (1971). Mental rotation of three-dimensional objects. *Science*, 171, 701–3.
- Sheridan, J. and Humphreys, G.W. (1993). A verbal-semantic category-specific recognition impairment. *Cognitive Neuropsychology*, 10, 143–84.
- Shewan, C.M. and Bandur, D.L. (1986). *Treatment of aphasia: a language-oriented approach*. London: Taylor & Francis.
- Shimamura, A.P. (1995). Memory and frontal lobe function. In M.S. Gazzaniga (ed.), *The Cognitive Neurosciences*. Cambridge, Mass.: MIT Press.
- Shimamura, A.P., Jernigan, T.L. and Squire, L.R. (1988). Korsakoff's syndrome: radiological (CT) findings and neuropsychological correlates. *Journal of Neuroscience*, 8, 4400–10.
- Shimamura, A.P., Salmon, D.P., Squire, L.R. and Butters, N. (1987). Memory dysfunction and word priming in dementia and amnesia. *Behavioural Neuroscience*, 101, 347–51.
- Shors, T.J. (2004). Memory traces of trace memories: neurogenesis, synaptogenesis and awareness. *Trends in Neurosciences*, 27, 5, 250–6.
- Shucard, D.W., Cummins, K.R. and McGee, M.G. (1984). Event-related brain potentials differentiate normal and disabled readers. *Brain and Language*, 21, 318–34.
- Shuttleworth-Edwards, A.B., Kemp, R.D., Rust, A.L., Muirhead, J.G.L., Hartman, N.P. and Radloff, S.E. (2004). Cross-cultural effects on IQ test performance: a review and preliminary normative indications on WAIS-III test performance. *Journal of Clinical and Experimental Neuropsychology*, 26, 7, 903–20.
- Sieratzki, J.S. and Woll, B. (1996). Why do mothers cradle babies on their left? *The Lancet*, 347, 1746–8.
- Silberman, E.K. and Weingartner, H. (1986). Hemispheric lateralization of functions related to emotion. *Brain and Cognition*, 5, 322–53.
- Silbersweig, D.A., Stern, E., Frith, C., Cahill, C., Holmes, A., Grootenck, S., Deaward, J., McKenna, P., Chua, S.E., Schnorr, L., Jones, T. and Frackowiak, R.S.J. (1995). A functional neuroanatomy of hallucinations in schizophrenia. *Nature*, 378, 176–9.
- Silver, M.H. *et al.* (2001). Cognitive functional status of age-confirmed centenarians in a population-based study. *Journal of Gerontology*, 56B, 134–40.
- Silveri, M.C., Leggio, M.G. and Molinari, M. (1994). The cerebellum contributes to linguistic production: a case of agrammatic speech following a right cerebellar lesion. *Neurology*, 44, 2047–50.
- Simos, P.G., Fletcher, J.M., Bergman, E., Breier, J.I., Foorman, B.R., Castillo, E.M., Davis, R.N., Fitzgerald, M. and Papanicolaou, A.C. (2002). Dyslexia-specific brain activation profile becomes normal following successful remedial training. *Neurology*, 58, 1203–13.
- Simpson, J., Yates, C.M., Gordon, A. and St Clair, D.M. (1984). Olfactory tubercle choline acetyltransferase activity in Alzheimer-type dementia, Down's syndrome and Huntington's disease. *Journal of Neurology, Neurosurgery and Psychiatry*, 47, 1138–9.
- Sinden, J.D., Hodges, H. and Gray, J.A. (1995). Neural transplantation and recovery of cognitive function. *Behavioural and Brain Sciences*, 18, 10–35.
- Singer, T.P., Trevor, A.J. and Castagnoli, N. (1987). Biochemistry of the neurotoxic action of MPTP. *Trends in Biochemical Sciences*, 12, 266–70.
- Singh, H. and O'Boyle, M.W. (2004). Interhemispheric interaction during global–local processing in mathematically gifted adolescents, average-ability youth, and college students. *Neuropsychology*, 18, 2, 371–7.
- Sirigu, A., Zalla, T., Pillon, B., Grafman, J., Agid, Y. and Dubois, B. (1995). Selective impairments in managerial knowledge following pre-frontal cortex damage. *Cortex*, 31, 301–6.
- Sittig, O. (1921). Störungen im Verhalten gegenüber Farben bei Aphasischen. *Monatsschrift für Psychiatrie und Neurologie*, 49, 159–87.
- Skels, H.M. (1966). Adult status of children with contrasting early life experiences. *Monographs of the Society for Research in Child Development*, 31, 1–65.
- Slooter, A.J.C., Tang, M.-X., van Duijn, C.M., Stern, Y., Off, A., Bell, K. *et al.* (1997). Apolipoprotein E4 and the risk of dementia with stroke: a population-based investigation. *Journal of the American Medical Association*, 277, 818–21.
- Small, B.J., Rosnick, C.B., Fratiglioni, L. and Bäckman, L. (2004). Apolipoprotein E and cognitive performance: a meta-analysis. *Psychology and Aging*, 19, 592–600.
- Small, D.M., Jones-Gottman, M., Zatorre, R.J., Petrides, M. and Evans, A.C. (1997). A role of the right anterior temporal lobe in taste quality recognition. *Journal of Neuroscience*, 17, 5136–42.
- Small, D.M., Zatorre, R.J., Dagher, A., Evans, A.C. and Jones-Gottman, M. (2001b). Changes in brain activity related to eating chocolate. *Brain*, 124, 1720–33.
- Small, D.M., Zatorre, R.J. and Jones-Gottman, M. (2001a). Increased intensity perception of aversive taste following right anteromedial temporal lobe removal in humans. *Brain*, 124, 1566–75.
- Smith, E.E. and Jonides, J. (1998). Neuroimaging analyses of human working memory. *Proceedings of the National Academy of Sciences*, 95, 12061–8.

- Smith, E.E., Jonides, J. and Koeppe, R.A. (1996). Dissociating verbal and spatial working memory using PET. *Cerebral Cortex*, 6, 11–20.
- Snowden, J.S., Thompson, J.C. and Neary, D. (2004). Knowledge of famous faces and names in semantic dementia. *Brain*, 127, 860–72.
- Snowling, M. and Hulme, C. (1989). A longitudinal case study of developmental phonological dyslexia. *Cognitive Neuropsychology*, 6, 379–401.
- Snowling, M., Stackhouse, J. and Rack, J. (1986). Phonological dyslexia and dysgraphia: a developmental analysis. *Cognitive Neuropsychology*, 3, 3, 309–39.
- Snowling, M., Van Wagtenonk, B. and Stafford, C. (1988). Object naming deficits in developmental dyslexia. *Journal of Research in Reading*, 11, 67–85.
- Sommer, I.E.C., Aleman, A., Ramsey, N., Bouma, A. and Kahn, R. (2001). Handedness, language lateralisation and anatomical asymmetry in schizophrenia. *British Journal of Psychiatry*, 178, 344–51.
- Sommer, I.E.C., Aleman, A., Bouma, A. and Kahn, R.S. (2004). Do women really have more bilateral language representation than men? A meta-analysis of functional imaging studies. *Brain*, 127, 1845–52.
- Son, Y.-J., Trachtenberg, J.T. and Thompson, W.J. (1996). Schwann cells induce and guide sprouting and reinnervation of neuromuscular junctions. *Trends in Neuroscience*, 19, 7, 280–5.
- Sowell, E.R. and Jernigan, T. (1998). Further MRI evidence of late brain maturation: limbic volume increases and changes asymmetries during childhood and adolescence. *Developmental Neuropsychology*, 14, 599–618.
- Sowell, E.R., Thompson, P.M., Holmes, C.J., Jernigan, T.L. and Toga, A.W. (1999). In vivo evidence for post-adolescent brain maturation in frontal and striatal regions. *Nature Neuroscience*, 2, 10, 859–61.
- Speedie, L.J., Rothi, L.J. and Heilman, K.M. (1982). Spelling dyslexia: a form of cross-cueing. *Brain and Language*, 15, 340–52.
- Spencer, D.D., Robbins, R.J., Noftolin, F., Marek, K.L., Vollmer, T., Leranthe, C., Roth, R.H., Price, L.H., Gjedde, A., Bunney, B.S., Sass, K.J., Elsworth, J.D., Kier, E.L., Makuch, R., Hoffer, P.B. and Redmonds, D.E. (1992). Unilateral transplantation of human fetal mesencephalic tissue into the caudate nucleus of patients with Parkinson's disease. *New England Journal of Medicine*, 327, 1541–8.
- Sperber, S. and Spinnler, H. (2003). Covert person recognition: its fadeout in a case of temporal lobe degeneration. *Cortex*, 39, 57–67.
- Sperry, R.W. (1968). Hemispheric disconnection and unity in conscious awareness. *American Psychologist*, 23, 723–33.
- Sperry, R.W., Gazzaniga, M.S. and Bogen, J.E. (1969). Interhemispheric relationships: the neocortical commissures; syndromes of hemisphere disconnection. In P.J. Vinken and G.W. Bruyn (eds), *Handbook of Clinical Neurology*, Vol. 4. Amsterdam: North-Holland.
- Spiers, P.A. (1987). Acalulia revisited: current issues. In G. Deloche and X. Seron (eds), *Mathematical Disabilities: A Cognitive Neuropsychological Perspective*. Hillsdale, NJ: Lawrence Erlbaum.
- Spreen, O. and Strauss, E. (1998). *A Compendium of Neuropsychological Tests: Administration, Norms, and Commentary*. 2nd Edition. New York: Oxford University Press.
- Sprengelmeyer, R., Rausch, M., Eysel, U.T. and Przuntek, H. (1998). Neural structures associated with recognition of facial expressions of basic emotions. *Proceedings of the Royal Society: Biological Sciences*, 265B, 1927–31.
- Sprengelmeyer, R., Young, A. W., Calder, A. J. (1996). Loss of disgust: perception of faces and emotions in Huntington's disease. *Brain*, 119, 1647–65.
- Sprengelmeyer, R., Young, A.W., Calder, A.J., Karnat, A., Lange, H.W. and Homberg, V. (1997). Loss of disgust: perception of faces and emotions in Huntington's disease. *Brain*, 119, 1647–65.
- Sprengelmeyer, R. et al. (1997a). Disgust implicated in obsessive-compulsive disorder. *Proceedings of the Royal Society: Biological Sciences*, B264, 1767–73.
- Sprengelmeyer, R., Young, A.W., Mahn, K., Schroeder, U., Woitalla, D., Buttner, T., Kuhn, W. and Przuntek, H. (2003). Facial expression recognition in people with medicated and unmedicated Parkinson's disease. *Neuropsychologia*, 41, 1047–57.
- Sprengelmeyer, R., Young, A.W., Sprengelmeyer, A., Calder, A.J., Rowland, D. and Perrett, D.I. (1997b). Recognition of facial expressions: selective impairment of specific emotions in Huntington's disease. *Cognitive Neuropsychology*, 14, 839–79.
- Springer, J.A., Binder, J.R., Hammeke, T.A., Swanson, S.J., Frost, J.A., Bellgowan, P.S.F., Brewer, C.C., Perry, H.M., Morris, G.L. and Mueller, W.M. (1999). Language dominance in neurologically normal and epilepsy subjects. *Brain*, 122, 2033–45.
- Squire, L.R. (1982). Comparisons between forms of amnesia: some deficits are unique to Korsakoff's syndrome. *Journal of Experimental Psychology: Learning, Memory and Cognition*, 8, 560–71.
- Squire, L.R. (1987). *Memory and Brain*. Oxford: Oxford University Press.
- Squire, L.R. (1994). Declarative and nondeclarative memory: multiple brain systems supporting learning and memory. In D.L. Schacter and E. Tulving (eds), *Memory Systems*. Cambridge, Mass.: MIT Press.
- Squire, L.R., Amaral, D.G., Zola-Morgan, S., Kritchevsky, M. and Press, G. (1989). Description of brain injury in the amnesic patient NA: based on magnetic resonance imaging. *Experimental Neurology*, 105, 23–35.
- Squire, L.R. and Moore, R.Y. (1979). Dorsal thalamic lesion in a noted case of human memory dysfunction. *Annals of Neurology*, 6, 503–6.

- Squire, L.R. and Slater, P.C. (1978). Anterograde and retrograde memory impairment in chronic amnesia. *Neuropsychologia*, 1, 313–21.
- Squire, L.R. and Zola-Morgan, S. (1988). Memory: brain systems and behaviour. *Trends in Neurosciences*, 11, 170–5.
- Squire, L.R., Zola-Morgan, S. and Alvarez, P. (1994). Functional distinctions within the medial temporal lobe memory system. What is the evidence? *Behavioural Brain Science*, 17, 495–6.
- Stahl, S.A. and Murray, B.A. (1994). Defining phonological awareness and its relationship to early reading. *Journal of Educational Psychology*, 86, 2, 221–34.
- Starkstein, S.E. and Robinson, R.G. (1991). The role of the frontal lobes in affective disorder. In H.S. Levin, H.M. Eisenberg and A.L. Benton (eds), *Frontal Lobe Function and Dysfunction*. New York: Oxford University Press.
- Steele, R.J. and Morris, R.G. (1999). Delay-dependent impairment of a matching-to-place task with chronic and intrahippocampal infusion of the NMDA-antagonist D-AP5. *Hippocampus*, 9, 118–36.
- Stein, J.F. (1991). Visuospatial sense, hemispheric asymmetry and dyslexia. In J.F. Stein (ed.), *Vision and Visual Dyslexia*. London: Macmillan.
- Steinmetz, H., Jancke, L., Kleinschmidt, A., Schlaug, G., Volkman, J. and Huang, Y. (1992). Sex but no hand differences in the isthmus of the corpus callosum. *Neurology*, 42, 749–52.
- Steinthal, H. (1871). *Abriss der Sprachwissenschaft*. Berlin.
- Stephan, K.E., Marshall, J.C., Friston, K.J., Rowe, J.B., Ritzl, A., Zilles, K. and Fink, G.R. (2003). Lateralized cognitive processes and lateralized task control in the human brain. *Science*, 301, 384–6.
- Stern, R.A. and White, T. (2003). *Neuropsychological Assessment Battery*. Lutz: Psychological Assessment Resources.
- Stewart, F., Parkin, A.J. and Hankin, N.M. (1992). Naming impairments following recovery from herpes simplex encephalitis: category-specific? *Quarterly Journal of Experimental Psychology*, 44A, 261–84.
- Stewart, L., Henson, R., Kampe, K., Walsh, V., Turner, R. and Frith, U. (2003). Brain changes after learning to read and play music. *Neuroimage*, 20, 71–83.
- Stewart, L., Walsh, V., Frith, U. and Rothwell, J. (2001). TMS produces two dissociable types of speech disruption. *Neuroimage*, 13, 472–8.
- St George, M., Kutas, M., Martinez, A. and Sereno, M.I. (1999). Semantic integration in reading: engagement of the right hemisphere during discourse processing. *Brain*, 122, 1317–25.
- Stiles, J., Moses, P., Passarotti, A., Dick, F.K. and Buxton, R. (2003). Exploring developmental change in the neural bases of higher cognitive functions: the promise of functional magnetic resonance imaging. *Developmental Neuropsychology*, 24, 2 and 3, 641–68.
- Stiles, J., Reilly, J., Paul, B. and Moses, P. (2005). Cognitive development following early brain injury: evidence for neural adaptation. *Trends in Cognitive Sciences*, 9, 3, 136–43.
- St James-Roberts, I. (1981). A reinterpretation of hemispherectomy data without functional plasticity of the brain. 1: Intellectual function. *Brain and Language*, 13, 31–53.
- Stoerig, P. and Cowey, A. (1997). Blindsight in man and monkey. *Brain*, 120, 535–59.
- Stoerig, P., Kleinschmidt, A. and Frahm, J. (1998). No visual responses in deenervated V1: High-resolution functional magnetic resonance imaging of a blindsight patient. *NeuroReport*, 9, 21–5.
- Stoicheff, M.L. (1960). Motivating instructions and language performance of dysphasic subjects. *Journal of Speech and Hearing Research*, 3, 75–85.
- Stone, A. and Valentine, T. (2003). Perspectives on prosopagnosia and models of face recognition. *Cortex*, 39, 31–40.
- Storandt, M., Botwinick, J. and Danziger, W.L. (1986). Longitudinal changes: patients with mild SDAT and matched healthy controls. In L.W. Poon (ed.), *Handbook for Clinical Memory Assessment of Older Adults*. Washington: APA.
- Stowe, L.A., Go, K.G., Pruijm, J., den Dunnen, W., Meiners, L.C. and Paans, A.M. (2000). Language localization in cases of left temporal lobe arachnoid cyst: evidence against interhemispheric reorganization. *Brain and Language*, 75, 347–58.
- Strange, P.G. (1992). *Brain Biochemistry and Brain Disorders*. New York: Oxford University Press.
- Strauss, E., Loring, D.W., Chelune, G., Hunter, M., Hermann, B., Perrine, K., Westerveld, M., Trenerry, M. and Barr, W. (1995). Predicting cognitive impairment in epilepsy: findings from the Bozeman epilepsy consortium. *Journal of Clinical and Experimental Neuropsychology*, 6, 909–17.
- Strauss, E. and Moscovitch, M. (1981). Perception of facial expression. *Brain and Language*, 13, 308–32.
- Stuss, D.T. and Benson, D.F. (1983). Emotional concomitants of psychosurgery. In K.M. Heilman and P. Satz (eds), *Neuropsychology of Human Emotion*. New York: Guilford Press.
- Stuss, D.T. and Benson, D.F. (1986). *The Frontal Lobes*. New York: Raven Press.
- Stuss, D.T., Gallup, G.G. and Alexander, M.P. (2001). The frontal lobes are necessary for ‘theory of mind’. *Brain*, 124, 279–86.
- Stuss, D.T., Gow, C.A. and Hetherington, C.R. (1992). ‘No longer Gage’: frontal lobe dysfunction and emotional changes. *Journal of Consulting and Clinical Psychology*, 60, 3, 349–59.

- Stuss, D.T. and Levine, B. (1996). The dementias: nosological and clinical factors related to diagnosis. *Brain and Cognition*, 31, 99–113.
- Stuss, D.T. and Richard, M.T. (1982). Neuropsychological sequelae of coma after head injury. In L.P. Ivan and D. Bruce (eds), *Coma: Physiopathology, Diagnosis and Management*. Springfield, Ill.: Charles C. Thomas.
- Subirana, A. (1969). Handedness and cerebral dominance. In P.J. Vinken and G.W. Bruyn (eds), *Handbook of Clinical Neurology*, Vol. 4. Amsterdam: North-Holland.
- Sugishita, M., Takayama, Y., Shiono, T., Yoshikawa, K. and Takahashi, V. (1996). Functional magnetic resonance imaging (fMRI) during mental writing with phonograms. *NeuroReport*, 7, 12, 1917–21.
- Sugiura, M., Kawashima, R., Nakagawa, M., Okada, K., Sato, T., Goto, R., Sato, K., Ono, S., Schormann, T., Zilles, K. and Fukada, H. (2000). Correlation between human personality and neural activity in cerebral cortex. *Neuroimage*, 11, 541–6.
- Suhr, J. and Gunstad, J. (2000). The effects of coaching on the sensitivity and specificity of malingering measures. *Archives of Clinical Neuropsychology*, 15, 5, 415–24.
- Sungaila, P. and Crockett, D.J. (1993). Dementia and the frontal lobes. In R.W. Parks, R.F. Zec and R.S. Wilson (eds), *Neuropsychology of Alzheimer's Disease and Other Dementias*. Oxford: Oxford University Press.
- Sutton, J.P., Whitton, J.L., Topa, M. and Moldofsky, H. (1986). Evoked potential maps in learning disabled children. *Electroencephalography and Clinical Neurophysiology*, 65, 399–404.
- Sutton, S., Braren, M., Zubin, J. and John, E.R. (1965). Evoked potential correlates of stimulus uncertainty. *Science*, 150, 1187–8.
- Sutton, S.K., Burnette, C.P., Mundy, P.C., Meyer, J., Vaughan, A., Sanders, C. and Yale, M. (2005). Resting cortical brain activity and social behaviour in higher functioning children with autism. *Journal of Child Psychology and Psychiatry*, 46, 2, 211–22.
- Sutton, S.K. and Davidson, R.J. (2000). Prefrontal brain electrical asymmetry predicts the evaluation of affective stimuli. *Neuropsychologia*, 38, 1723–33.
- Sutton-Spence, R. and Woll, B. (1999). *The Linguistics of British Sign Language*. Cambridge: Cambridge University Press.
- Svebak, S. (1975). Respiratory patterns as predictors of laughter. *Psychophysiology*, 12, 62–5.
- Svebak, S. (1977). Some characteristics of resting respiration as predictors of laughter. In A.J. Chapman and H.C. Foot (eds), *It's a Funny Thing, Humour*. Oxford: Pergamon Press.
- Svebak, S. (1982). The effect of mirthfulness upon amount of discordant right–left occipital EEG alpha. *Motivation and Emotion*, 6, 133–43.
- Svennilson, E., Torvik, A., Lowe, R. and Leksell, L. (1960). Treatment of parkinsonism by stereotactic thermolesions in the pallidum region. *Acta Psychiatrica Scandinavica*, 35, 358–79.
- Sweet, J.J., Moberg, P.J. and Suchy, Y. (2000). Ten-year follow-up survey of clinical neuropsychologists: Part 1. Practices and beliefs. *The Clinical Neuropsychologist*, 14, 18–37.
- Tagamets, M.A., Novick, J.M., Chalmers, M.L. and Friedman, R.B. (2000). A parametric approach to orthographic processing in the brain: an fMRI study. *Journal of Cognitive Neuroscience*, 12, 2, 281–97.
- Tarr, M.J. and Cheng, Y.D. (2003). Learning to see faces and objects. *Trends in Cognitive Sciences*, 7, 23–30.
- Tate, R.L. and McDonald, S. (1995). What is apraxia? The clinician's dilemma. *Neuropsychological Rehabilitation*, 5, 273–97.
- Tatsumi, I.F., Fushimi, T., Sadato, N., Kawashima, R., Yokoyama, E., Kanno, I. and Senda, M. (1999). Verb generation in Japanese – a multicenter PET activation study. *Neuroimage*, 9, 154–64.
- Taylor, L.B. (1979). Psychological assessment of neurosurgical patients. In T. Rasmussen and R. Marino (eds), *Functional Neurosurgery*. New York: Raven Press.
- Taylor, M.J. (1993). Maturational changes in ERPs to orthographic and phonological tasks. *Electroencephalography and Clinical Neurophysiology*, 88, 494–507.
- Taylor, M.J. and Keenan, N.K. (1990). Event-related potentials to visual and language stimuli in normal and dyslexic children. *Psychophysiology*, 27, 3, 318–27.
- Tegner, R. and Levander, M. (1991). The influence of stimulus properties on visual neglect. *Journal of Neurology, Neurosurgery and Psychiatry*, 54, 1943–51.
- Temple, C.M. and Marshall, J.C. (1983). A case study of developmental phonological dyslexia. *British Journal of Psychology*, 74, 517–33.
- Tenhula, W.N. and Sweet, J.J. (1996). Double cross-validation of the booklet category test in detecting malingered traumatic brain injury. *The Clinical Neuropsychologist*, 10, 1, 104–16.
- Terry, R.D., Maslia, H., Salmon, D.P., Butters, N., DeTeresa, R., Hill, R., Hansen, L.A. and Katzman, R. (1991). Physical basis of cognitive alterations in Alzheimer's disease: synapse loss is the major correlate of cognitive impairment. *Annals of Neurology*, 30, 572–80.
- Teszner, D., Tzavaras, A., Gruner, J. and Hecaen, H. (1972). L'asymétrie droite–gauche du planum tempore: a propos de l'étude anatomique de 100 cerveaux. *Révue Neurologique*, 126, 444–9.
- Teter, B. and Ashford, J.W. (2002). Neuroplasticity in Alzheimer's disease. *Journal of Neuroscience Research*, 70, 402–37.

- Teter, B. and Finch, C.E. (2004). Caliban's heritage and the genetics of neuronal aging. *Trends in Neurosciences*, 27, 10, 627–32.
- Teuber, H.L. (1965). Some needed revisions of the classical views of agnosia. *Neuropsychologia*, 3, 371–8.
- Teuber, H.L. (1975). Recovery of function after brain injury in man. *Ciba Foundation Symposium*, 34, 159–90.
- Teuber, H.L., Milner, B. and Vaughan, H.G. (1968). Persistent anterograde amnesia after stab wound of the basal brain. *Neuropsychologia*, 1, 267–82.
- Teuber, H.L. and Mishkin, M. (1954). Judgement of visual and postural vertical after brain injury. *Journal of Psychology*, 38, 161–75.
- Thal, L.J. (1992). Cholinomimetic therapy in Alzheimer's disease. In L.R. Squire and N. Butters (eds), *Neuropsychology of Memory*. New York: Guilford Press.
- Thomas, K.M., Drevets, W.C., Whalen, P.J., Eccard, C.H., Dahl, R.E., Ryan, N.D. et al. (2001). Amygdala response to facial expressions in children and adults. *Biological Psychiatry*, 49, 309–16.
- Thomas-Anterion, C., Laurent, B., Le Henaff, H., Foyatier-Michel, N. and Michel, D. (1994). Spelling acquisition impairments: a neuropsychological study in 2 adolescents with developmental dysgraphia. *Neurologique*, 150, 12, 827–34.
- Thompson, C.K., Fix, S. and Gitelman, D. (2002). Selective impairment of morphosyntactic production in a neurological patient. *Journal of Neurolinguistics*, 15, 189–207.
- Thorndike, R.L., Hagen, E.P. and Sattler, J.M. (1987). *Stanford-Binet Intelligence Scale* (4th edition). Chicago: Riverside.
- Tippett, L.J., Miller, L.A. and Farah, M.J. (2000). Prosopagnosia: a selective impairment in face learning. *Cognitive Neuropsychology*, 17, 1/2/3, 241–55.
- Tognola, G. and Vignolo, L.A. (1980). Brain lesions associated with oral apraxia in stroke patients: a clinico-neuroradiological investigation with CT scan. *Neuropsychologia*, 18, 257–71.
- Tohgi, H., Watanabe, K., Takahashi, H., Yonezawa, H., Hatano, K. and Sasaki, T. (1994). Prosopagnosia without topographagnosia and object agnosia associated with a lesion confined to the right occipitotemporal region. *Journal of Neurology*, 241, 470–4.
- Tomarken, A.J., Davidson, R.J. and Henriques, J.B. (1990). Resting frontal brain asymmetry predicts affective responses to films. *Journal of Personality and Social Psychology*, 59, 4, 791–801.
- Tomarken, A.J., Davidson, R.J., Wheeler, R.E. and Doss, R.C. (1992). Individual differences in anterior brain asymmetry and fundamental dimensions of emotion. *Journal of Personality and Social Psychology*, 62, 676–87.
- Topper, R., Mottaghy, F.M., Brugmann, M., Noth, J. and Huber, W. (1998). Facilitation of picture naming by focal transcranial magnetic stimulation of Wernicke's area. *Experimental Brain Research*, 121, 371–8.
- Torrey, E.F., Webster, M., Knable, M., Johnston, N. and Yolken, R.H. (2000). Foundation brain collection and Neuropathology Consortium. *Schizophrenia Research*, 44, 151–5.
- Tranel, D., Bechara, A. and Denburg, N.L. (2002). Asymmetric functional roles of right and left ventromedial prefrontal cortices in social conduct, decision-making and emotional processing. *Cortex*, 38, 589–612.
- Tranel, D. and Damasio, A.R. (1985). Knowledge without awareness: an autonomic index of facial recognition by prosopagnosics. *Science*, 228, 1453–4.
- Tranel, D., Damasio, A.R. and Damasio, H. (1988). Intact recognition of facial expression, gender and age in patients with impaired recognition of face identity. *Neurology*, 38, 690–6.
- Trevarthen, C. (1987). Subcortical influences on cortical processing in 'split' brains. In D. Ottoson (ed.), *Duality and Unity of the Brain*. London: Macmillan.
- Trott, C.T., Friedman, D., Ritter, W. and Fabiani, M. (1997). Item and source memory: differential age effects revealed by event-related potentials. *NeuroReport*, 8, 3373–8.
- Trueblood, W. and Schmidt, M. (1993). Malingering and other validity considerations in the neuropsychological evaluation of mild head injury. *Journal of Clinical and Experimental Neuropsychology*, 15, 4, 578–90.
- Tsai, G. and Coyle, J.T. (2002). Glutamatergic mechanisms in schizophrenia. *Annual Review of Pharmacology and Toxicology*, 42, 165–79.
- Tucker, D.M., Stenslie, C.E., Roth R.S., and Shearer, S.L. (1981). Right frontal lobe activation and right hemisphere performance decrement during a depressed mood. *Archives of General Psychiatry*, 38, 169–74.
- Tulving, E., Kapur, S., Markowitsch, H.J., Craik, F.I. and Houle, S. (1994). Hemispheric encoding/retrieval asymmetry in episodic memory: positron emission tomography findings. *Proceedings of the National Academy of Sciences USA*, 91, 2016–20.
- Tulving, E. and Markowitsch, H.J. (1998). Episodic and declarative memory: role of the hippocampus. *Hippocampus*, 8, 198–204.
- Tulving, E. and Schacter, D.L. (1990). Priming and human memory systems. *Science*, 247, 301–6.
- Turkewitz, G. (1988). A prenatal source for the development of hemispheric specialisation. In D.L. Molfese and S.J. Segalowitz (eds), *Brain Lateralization in Children: Developmental Implications*. New York: Guilford Press.

- Turnbull, O.H. and Matheson, E.A. (1996). Left-sided cradling: comment on Sieratzki and Woll. *The Lancet*, 348, 691.
- Tzourio, N., Nkanga-Ngila, B. and Mazoyer, B. (1998). Left planum temporale surface correlates with functional dominance during story listening. *NeuroReport*, 9, 829–33.
- Ullian, E.M., Sapperstein, S.K., Christopherson, K.S. and Barres, B.A. (2001). Control of synapse number by glia. *Science*, 291, 657–60.
- Ullman, M.T., Bergida, R. and O'Craven, K. (1997). Distinct fMRI activation patterns for regular and irregular past tense. *Neuroimage*, 5, S549.
- Ullman, M.T., Corkin, S., Coppola, M., Hickok, G. and Growdon, J.H. (1997). A neural dissociation within language: evidence that the mental dictionary is part of declarative memory, and that grammatical rules are processed by the procedural system. *Journal of Cognitive Neuroscience*, 9, 266–76.
- Ullman, M.T., Pancheva, R., Love, T., Yee, E., Swinney, D. and Hickok, G. (2005). Neural correlates of lexicon and grammar: evidence from the production, reading and judgement of inflection in aphasia. *Brain and Language*, 93, 185–238.
- Ungerleider, L. and Mishkin, M. (1982). Two cortical visual systems. In D.J. Ingle, M.A. Goodale and R.J.W. Mansfield (eds), *Analysis of Visual Behaviour*. Cambridge, Mass.: MIT Press.
- Urry, H.L., Nitschke, J.B., Dolski, I., Jackson, D.C., Dalton, K.M., Mueller, C.J., Rosenkranz, M.A., Ryff, C.D., Singer, B.H. and Davidson, R.J. (2004). Making a life worth living: neural correlates of well-being. *Psychological Science*, 15, 6, 367–72.
- Vallar, G. (2001). Extrapersonal visual unilateral spatial neglect and its neuroanatomy. *Neuroimage*, 14, S52–58.
- Vallar, G. and Baddeley, A.D. (1984). Fractionation or working memory: neuropsychological evidence for a phonological shorter-term store. *Journal of Verbal Learning and Verbal Behavior*, 23, 151–61.
- Vallar, G. and Papagno, C. (1986). Phonological short-term store and the nature of the recency effect. *Brain and Cognition*, 5, 428–42.
- Vandenberghe, R., Duncan, J., Dupont, P. and Ward, R. (1997). Attention to 1 or 2 features in left or right visual field: a PET study. *Journal of Neuroscience*, 17, 10, 3739–50.
- Vandenberghe, R., Price, C., Wise, R., Josephs, O. and Frackowiak, R.S.J. (1996). Functional anatomy of a common semantic system for words and pictures. *Nature*, 383, 254–6.
- Van den Broek, M.D., Bradshaw, C.M. and Szabadi, E. (1993). Utility of the Modified Wisconsin Card Sorting Test in neuropsychological assessment. *British Journal of Clinical Psychology*, 32, 333–43.
- Van den Broek, M.D., Schady, W. and Coyne, H.J. (1995). *Living with Head Injury*. Manchester: Manchester University Press.
- Van Horn, J.D., Berman, K.F. and Weinberger, D.R. (1996). Functional lateralization of the prefrontal cortex during traditional frontal lobe tasks. *Biological Psychiatry*, 39, 389–99.
- Van Lancker, D. (1997). Rags to riches: our increasing appreciation of cognitive and communicative abilities of the human right cerebral hemisphere. *Brain and Language*, 57, 1–11.
- Van Lancker, D. and Cummings, J.L. (1999). Expletives: neurolinguistic and neurobehavioural perspectives on swearing. *Brain Research Reviews*, 31, 83–104.
- Vanlancker-Sidtis, D. (2004). When only the right hemisphere is left: studies in language and communication. *Brain and Language*, 91, 199–211.
- Vanlancker-Sidtis, D., McIntosh, A.R. and Grafton, S. (2003). PET activation studies comparing two speech tasks widely used in surgical mapping. *Brain and Language*, 85, 245–61.
- Van Petten, C. and Kutas, M. (1990). Interactions between sentence context and word frequency in event-related brain potentials. *Memory and Cognition*, 18, 380–93.
- Van Strien, J.W. and Bouma, A. (1995). Sex and familial sinistrality differences in cognitive ability. *Brain and Cognition*, 27, 137–46.
- Vargha-Khadem, F., Gadian, D.G., Watkins, K.E., Connelly, A., Van Paesschen, W. and Mishkin, M. (1997). Differential effects of hippocampal pathology in episodic and semantic memory. *Science*, 277, 5324, 876–80.
- Vargha-Khadem, F., O'Gorman, A.M. and Watters, G.V. (1985). Aphasia and handedness in relation to hemispheric side, age at injury, and severity of cerebral lesion during childhood. *Brain*, 108, 677–96.
- Varia, I. and Rauscher, F. (2002). Treatment of generalized anxiety disorder with citalopram. *International Journal of Clinical Psychopharmacology*, 17, 103–7.
- Vickery, C.D., Berry, D.T.R., Dearth, C.S., Vagnini, V.L., Baser, R.E., Cragar, D.E. and Orey, S.A. (2004). Head injury and the ability to feign neuropsychological deficits. *Archives of Clinical Neuropsychology*, 19, 37–48.
- Victor, M., Adams, R.D. and Collins, G.H. (1971). *The Wernicke-Korsakoff Syndrome*. New York: Davis.
- Vidyasagar, T.R. and Pammer, K. (1999). Impaired visual search in dyslexia relates to the role of the magnocellular pathway in attention. *NeuroReport*, 10, 1283–7.
- Vigliocco, G., Vinson, D.P., Martin, R.C. and Garrett, M.F. (1999). Is 'count' and 'mass' information available when the noun is not? An investigation of tip of the tongue states and anomia. *Journal of Memory and Language*, 40, 534–58.
- Vignolo, L.A. (1964). Evolution of aphasia and language rehabilitation: a retrospective exploratory study. *Cortex*, 1, 344–67.

- Vignolo, L.A. (1969). Auditory agnosia: a review and report of recent evidence. In A.L. Benton (ed.), *Contributions to Clinical Neuropsychology*. Chicago: Aldine.
- Vogel, J.L., Bowers, C.A. and Vogel, D.S. (2003). Cerebral lateralization of spatial abilities: a meta-analysis. *Brain and Cognition*, 52, 197–204.
- Vogt, O. and Vogt, C. (1903). Zur anatomischen Gliederung des cortex cerebri. *Journal of Psychology and Neurology*, 2, 160–80.
- Von Cramon, D. and Kerkhoff, G. (1993). On the cerebral organization of elementary visuo-spatial perception. In B. Gulyas, D. Ottoson and P.E. Roland (eds), *Functional Organization of the Human Visual Cortex*. Oxford: Pergamon Press.
- Von Monakow, C. (1914). *Die Lokalisation im Grosshirn und der Abbau der Funktion durch Koertikale Herde*. Wiesbaden: Bergmann.
- Voyer, D. (1998). On the reliability and validity of noninvasive laterality measures. *Brain and Cognition*, 36, 209–36.
- Vythilingam, M., Anderson, E.R. and Goddard, A. (2000). Temporal lobe volume in panic disorder – a quantitative magnetic resonance imaging study. *Psychiatry Research*, 99, 75–82.
- Wada, J.A., Clarke, R. and Hamm, A. (1975). Cerebral hemispheric asymmetry in humans: cortical speech zones in 100 adult and 100 infant brains. *Archives of Neurology* (Chicago), 32, 239–46.
- Wada, J.A. and Rasmussen, T. (1960). Intracarotid injection of sodium amytal for the lateralization of cerebral speech dominance. *Journal of Neurosurgery*, 17, 266–82.
- Wager, T.D., Phan, K.L., Liberzon, I. and Taylor, S.F. (2003). Valence, gender, and lateralization of functional brain anatomy in emotion: a meta-analysis of findings from neuroimaging. *NeuroImage*, 19, 513–31.
- Walker, E., Grimes, K., Davis, D. and Smith, A. (1993). Childhood precursors of schizophrenia: facial expressions of emotion. *American Journal of Psychiatry*, 150, 1654–60.
- Walker, E. and Lewine, R.J. (1990). Prediction of adult-onset schizophrenia from childhood home movies of the patients. *American Journal of Psychiatry*, 147, 1052–56.
- Walker, E., Savoie, T. and Davis, D. (1994). Neuromotor precursors of schizophrenia. *Schizophrenia Bulletin*, 20, 441–52.
- Wallesch, C.-W., Herrmann, M. and Bartels, C. (2002). Wernicke's cases of conduction aphasia. In C. Code, C.-W. Wallesch, Y. Joannette and A.R. Lecours (eds), *Classic Cases in Neuropsychology*, Vol. 2. Hove, UK: Psychology Press.
- Walsh, K.W. (1991). *Understanding Brain Damage: A Primer of Neuropsychological Evaluation*. Edinburgh: Churchill Livingstone.
- Walter, H., Bretschneider, V., Gron, G., Zurowski, B., Wunderlich, A.P., Tomczak, R. and Spitzer, M. (2003). Evidence for quantitative domain dominance for verbal and spatial working memory in frontal and parietal cortex. *Cortex*, 39, 4/5, 897–912.
- Wang, E., Peach, R.K., Xu, Y., Schneck, M. and Manry, C. (2000). Perception of dynamic acoustic patterns by an individual with unilateral verbal auditory agnosia. *Brain and Language*, 73, 442–55.
- Wapner, W., Hamby, S. and Gardner, H. (1981). The role of the right hemisphere in the apprehension of complex linguistic materials. *Brain and Language*, 14, 15–33.
- Wapner, W., Judd, T. and Gardner, H. (1978). Visual agnosia in an artist. *Cortex*, 14, 343–64.
- Ward, J. (2003). Encoding and the frontal lobes: a dissociation between retrograde and anterograde memories. *Cortex*, 39, 791–812.
- Warren, J.M., Abplanalp, J.M. and Warren, H.B. (1967). The development of handedness in cats and rhesus monkeys. In H.W. Stevenson, E.H. Hess and H.L. Rheingold (eds), *Early Behaviour: Comparative Developmental Approaches*. New York: John Wiley & Sons.
- Warrington, E.K. (1982). Neuropsychological studies of object recognition. *Philosophical Transactions of the Royal Society of London*, Series B, 295, 411–23.
- Warrington, E.K. (1984). *Recognition Memory Test*. Los Angeles: Western Psychological Services.
- Warrington, E.K. (1985). Agnosia: the impairment of object recognition. In P.J. Vinken, G.W. Gruyn and Klawans, H.L. (eds), *Handbook of Clinical Neurology*. Amsterdam: Elsevier.
- Warrington, E.K. (1986). *The Camden Memory Tests*. Hove, UK: Psychology Press.
- Warrington, E.K. and James, M. (1967). An experimental investigation of facial recognition in patients with unilateral cerebral lesions. *Cortex*, 3, 317–26.
- Warrington, E.K. and James, M. (1986). Visual object recognition in patients with right hemisphere lesions: axes or features? *Perception*, 15, 355–66.
- Warrington, E.K., Logue, V. and Pratt, R.T.C. (1971). The anatomical localization of selective impairment of short-term memory. *Neuropsychologia*, 9, 377–87.
- Warrington, E.K. and Shallice, T. (1980) Word form dyslexia. *Brain*, 103, 99–112.
- Warrington, E.K. and Shallice, T. (1984). Category specific semantic impairments. *Brain*, 107, 829–53.
- Warrington, E.K. and Taylor, A.M. (1973). Contribution of the right parietal lobe to object recognition. *Cortex*, 9, 152–64.
- Watson, J.B. (1924). *Psychology from the Standpoint of a Behaviourist*. Philadelphia: Lippincott.
- Watson, R.T. and Heilman, K.M. (1983). Callosal apraxia. *Brain*, 106, 391–403.
- Weber-Fox, C., Davis, L.J. and Cuadrado, E. (2003). Event-related brain potential markers of high-language proficiency in adults. *Brain and Language*, 85, 231–44.

- Wechsler, A.F., Verity, M.A., Rosenschien, S., Fried, I. and Sciebel, A.B. (1982). Pick's disease: a clinical, computed tomographic and histological study with Golgi impregnation. *Archives of Neurology*, 39, 287–90.
- Wechsler, D. (1955). *Manual for the Wechsler Adult Intelligence Scale*. New York: Psychological Corporation.
- Wechsler, D. (1981). *Manual for the Wechsler Adult Intelligence Scale – Revised*. New York: Psychological Corporation.
- Wechsler, D. (1997a). *Wechsler Adult Intelligence Scale – III*. San Antonio: Psychological Corporation.
- Wechsler, D. (1997b). *Wechsler Memory Scale* (3rd edition). San Antonio: Psychological Corporation.
- Wechsler, D. and Stone, C.P. (1974). *Wechsler Memory Scale Manual*. San Antonio: Psychological Corporation.
- Weddell, R.A. (1994). Effects of subcortical lesion site on human emotional behaviour. *Brain and Cognition*, 25, 161–93.
- Weddell, R.A., Miller, J.D. and Trevarthen, C. (1990). Voluntary emotional facial expressions in patients with focal cerebral lesions. *Neuropsychologia*, 28, 49–60.
- Weekes, B. and Coltheart, M. (1996). Surface dyslexia and surface dysgraphia: treatment studies and their theoretical implications. *Cognitive Neuropsychology*, 13, 2, 277–315.
- Weigl, E. (1941). On the psychology of so-called processes of abstraction. *Journal of Abnormal Psychology*, 36, 3–33.
- Weinberger, D.R., Luchins, D.J., Morihisa, J. and Wyatt, R.J. (1982). Asymmetrical volumes of the right and left frontal and occipital regions of the human brain. *Annals of Neurology*, 11, 97–100.
- Weiner, B. (1985). An attributional theory of achievement motivation and emotion. *Psychological Review*, 92, 548–73.
- Weingartner, H., Grafman, J., Boutelle, W., Kaye, W. and Martin, P.R. (1983). Forms of memory failure. *Science*, 221, 380–2.
- Weiskrantz, L. (1985). On issues and theories of the human amnesic syndrome. In N.M. Weinberger, J.L. McGaugh and G. Lynch (eds), *Memory Systems of the Brain*. New York: Guilford Press.
- Weiskrantz, L. (1986). *Blindsight: A Case Study and Implications*. Oxford: Oxford University Press.
- Weiskrantz, L. (1998). Consciousness and commentaries. In S.R. Hameroff, A.W. Kaszniak and A.C. Scott (eds), *Towards a Science of Consciousness*, Vol. 2. Cambridge, Mass.: MIT Press.
- Weiskrantz, L., Cowey, A. and Hodinott-Hill, I. (2002). Prime-sight in a blindsight subject. *Nature Neuroscience*, 5, 101–2.
- Weiskrantz, L., Roa, A., Hodinott-Hill, I., Nobre, A.C. and Cowey, A. (2003). Brain potentials associated with conscious after-effects induced by unseen stimuli in a blindsight subject. *Proceedings of the National Academy of Sciences*, 100, 10500–5.
- Wellman, H.M., Cross, D. and Watson, J. (2001). Meta-analysis of theory-of-mind development: the truth about false belief. *Child Development*, 72, 655–84.
- Wernicke, C. (1874) *Der Aphasische Symptomenkomplex*. Breslau, Poland: Cohn and Weigert.
- Wessinger, C.W., Van Meter, J., Van Lare, J., Pehar, J. and Rauschecker, J.P. (2001). Hierarchical organization of the human auditory cortex revealed by functional magnetic resonance imaging. *Journal of Cognitive Neuroscience*, 13, 1, 1–7.
- West, R.L. (1996). An application of prefrontal cortex function theory of cognitive aging. *Psychological Bulletin*, 120, 2, 272–92.
- Wheeler, M.A. and Stuss, D.T. (2003). Remembering and knowing in patients with frontal lobe injuries. *Cortex*, 39, 827–46.
- Wheeler, R.W., Davidson, R.J. and Tomarken, A.J. (1993). Frontal brain asymmetry and emotional reactivity: a biological substrate of affective style. *Psychophysiology*, 30, 82–9.
- Whitehouse, P.J., Lerner, A. and Hedera, P. (1993). Dementia. In K.M. Heilman and E. Valenstein (eds), *Clinical Neuropsychology* (3rd edition). New York: Oxford University Press.
- Whiteley, A.M. and Warrington, E.K. (1978). Selective impairment of topographical memory: A single case study. *Journal of Neurology, Neurosurgery and Psychiatry*, 41, 575–8.
- Widner, H., Tetrud, J., Rehncrona, S., Snow, B., Brundin, P., Gustavii, B., Bjorklund, A., Lindvall, O. and Langston, J.W. (1992). Bilateral fetal mesencephalic grafting in two patients with parkinsonism induced by 1-methyl-4-phenyl-1,2,3,6-tetrahydropyridine (MPTP). *New England Journal of Medicine*, 327, 1556–63.
- Widom, C.S. (1978). A methodology for studying non-institutionalized psychopaths. In R.D. Hare and D. Schalling (eds), *Psychopathic Behaviour: Approaches to Research*. Chichester, UK: John Wiley & Sons.
- Wigan, A.L. (1844). *The Duality of the Mind*. London: Longman, Brown and Green.
- Wiggins, E.C. and Brandt, J. (1988). The detection of simulated amnesia. *Law and Human Behaviour*, 12, 57–78.
- Wiig, E.H. and Semel, E.M. (1976). *Language Disability in Children and Adolescents*. Ohio: Charles Merrill.
- Wik, G., Fredrikson, M., Ericson, K., Eriksson, L., Stone-Elander, S. and Greitz, T. (1993). A functional cerebral response to frightening visual stimulation. *Psychiatry, Research and Neuroimaging*, 50, 15–24.
- Wikensky, A.E., Schafe, G.E. and LeDoux, J.E. (2000). Functional inactivation of amygdala nuclei during acquisition of Pavlovian fear conditioning. *Society of Neuroscience Abstracts*, 26, 465.
- Wilcock, G.K., Esiri, M.M., Bowen, D.M. and Hughes, A.O. (1988). The differential involvement of subcortical nuclei in senile dementia of the Alzheimer's type.

- Journal of Neurology, Neurosurgery and Psychiatry*, 51, 842–9.
- Wildgruber, D., Hertrich, I., Riecker, A., Erb, M., Anders, S., Grodd, W. and Ackermann, H. (2004). Distinct frontal regions subserve evaluation of linguistic and emotional aspects of speech intonation. *Cerebral Cortex*, 14, 12, 1384–9.
- Wilensky, A.E., Schafe, G.E. and LeDoux, J.E. (1999). The amygdala modulates memory consolidation of fear-motivated inhibitory avoidance learning but not classical fear conditioning. *Journal of Neuroscience*, 20, 7059–66.
- Wilkins, R.H. (1992). *Neurosurgical Classics*. USA: American Association of Neurological Surgeons.
- Williams, J.M. (1991). *Memory Assessment Scales*. Odessa: Psychological Assessment Resources.
- Willows, D.M., Kruk, R.S. and Corcos, E. (1993). *Visual Processes in Reading and Reading Disabilities*. Hillsdale, NJ: Lawrence Erlbaum.
- Wilson, B.A. (1991). Long-term prognosis of patients with severe memory disorders. *Neuropsychological Rehabilitation*, 1, 117–34.
- Wilson, B.A. (1995). Rehabilitation. In J.G. Beaumont, P.M. Kenealy and M.J.C. Rogers (eds), *Blackwell Dictionary of Neuropsychology*. Oxford: Basil Blackwell.
- Wilson, B.A., Calre, L. and Baddeley, A. (1999). *The Rivermead Behavioural Memory Test – Extended Version*. Bury St Edmunds: Thames Valley Test.
- Wilson, B.A., Cockburn, J. and Baddeley, A. (1985). *The Rivermead Behavioural Memory Test*. Bury St Edmunds: Thames Valley Test.
- Wilson, B.A., Cockburn, J. and Baddeley, A. (2003). *The Rivermead Behavioural Memory Test – II*. Bury St Edmunds: Thames Valley Test.
- Wilson, B.A., Evans, J.J. and Emslie, H. (1998). The development of an ecologically valid test for assessing patients with dysexecutive syndrome. *Neuropsychological Rehabilitation*, 8, 213–28.
- Wilson, B.A., J.C., and Hughes, E. (1997). Coping with amnesia: The natural history of a compensatory memory system. In A.J. Parkin (ed.), *Case Studies in the Neuropsychology of Memory*. Hove, UK: Psychology Press.
- Wilson, B.A. and Watson, P.C. (1996). A practical framework for understanding compensatory behaviour in people with organic memory impairment. *Memory*, 4, 5, 465–86.
- Wilson, B.A. and Wearing, D. (1995). Prisoner of consciousness: a state of just waking following herpes simplex encephalitis. In R. Campbell and M.A. Conway (eds), *Broken Memories: Case Studies in Memory Impairment*. Oxford: Basil Blackwell.
- Wilson, S.L. and McMillan, T.M. (1991). Computer-based assessment in neuropsychology. In J.R. Crawford, D.M. Parker and M.M. McKinlay (eds), *A Handbook of Neuropsychological Assessment*. Hove, UK: Lawrence Erlbaum.
- Winkler, C., Kirik, D. and Bjorklund, A. (2005). Cell transplantation in Parkinson's disease: How can we make it work? *Trends in Neurosciences*, 28, 2, 86–92.
- Winkler, C., Kirik, C.D., Bjorklund, A. and Dunnett, S.D. (2000). Transplantation in the rat model of Parkinson's disease: ectopic vs homotopic graft placement. *Progress in Brain Research*, 127, 233–65.
- Winner, E. and Gardner, H. (1977). The comprehension of metaphor in brain-damaged patients. *Brain*, 100, 719–27.
- Wise, R.J.S., Scott, S.K., Blank, C., Mummery, C.J., Murphy, K. and Warburton, E.A. (2001). Separate neural subsystems within 'Wernicke's area'. *Brain*, 124, 83–95.
- Witelson, S.F. (1977). Neural and cognitive correlates of developmental dyslexia: age and sex differences. In C. Shagass, S. Gershon and A.J. Friedhoff (eds), *Psychopathology and Brain Dysfunction*. New York: Raven Press.
- Witelson, S.F. (1985). The brain connection: the corpus callosum is larger in left handers. *Science*, 229, 665–8.
- Witelson, S.F. and Pallie, W. (1973). Left hemisphere specialization for language in the newborn: neuroanatomical evidence of asymmetry. *Brain*, 96, 641–6.
- Wittchen, H.U. (2002). Generalized anxiety disorder: prevalence, burden and cost to society. *Depression and Anxiety*, 16, 162–71.
- Wolpert, I. (1924). Die simultanagnosie: Störung der gesamt Auffassung. *Z. Gesamte Neurol. Psychiatr.*, 93, 397–413.
- Wood, E.K. (1988). Less sinister statistics from baseball records. *Nature*, 335, 1042.
- Wood, F.B., Flowers, D.L. and Naylor, C.E. (1991). Cerebral laterality in functional neuroimaging. In F.L. Kitterle (ed.), *Cerebral Laterality: Theory and Research*. Hillsdale, NJ: Lawrence Erlbaum.
- Wood, R.L.I. and Rutterford, N.A. (2004). Relationships between measured cognitive ability and reported psychosocial activity after bilateral frontal lobe injury: an 18-year follow-up. *Neuropsychological Rehabilitation*, 14, 3, 329–50.
- Woodruff-Pak, D.S. (1997). *The Neuropsychology of Aging*. Oxford: Basil Blackwell.
- Woods, B.T. (1980). The restricted effects of right-hemisphere lesions after age one: Wechsler test data. *Neuropsychologia*, 18, 65–70.
- Woods, B.T. (1987). Impaired speech shadowing after early lesions of either hemisphere. *Neuropsychologia*, 25, 519–25.
- Woods, B.T. and Carey, S. (1979). Language deficits after apparent clinical recovery from childhood aphasia. *Annals of Neurology*, 6, 405–9.
- Woods, B.T. and Teuber, H.-L. (1978). Mirror movements after childhood hemiparesis. *Neurology*, 28, 1152–8.
- Woods, R.T. (1994). Problems in the elderly. In S.J.E. Lindsey and G.E. Powell (eds), *Handbook of Clinical Adult Psychology*. London: Routledge.

- Woodward, S.H. (1988). An anatomical model of hemispheric asymmetry. *Journal of Clinical and Experimental Neuropsychology*, 10, 68.
- World Health Organization (1979). *Schizophrenia: An International Follow-up Study*. Geneva: WHO.
- World Health Organization (2002). *The World Health Report 2002: Reducing Risks, Promoting Healthy Life*. Geneva: WHO.
- Wright, C.I., Martis, B., McMullin, K., Shin, L.M. and Rauch, S.L. (2003). Amygdala and insular responses to emotionally valenced human faces in small animal specific phobia. *Biological Psychiatry*, 54, 1067–76.
- Wurtman, R.J. and Wurtman, J.J. (1989). Carbohydrates and depression. *Scientific American*, 260, 1, 50–7.
- Wyke, M. (1967). The effect of brain lesions on the rapidity of arm movement. *Neurology*, 17, 1113–30.
- Wyler, F., Graves, R. and Landis, T. (1987). Cognitive task influence on relative hemispheric motor control. *Journal of Clinical and Experimental Neuropsychology*, 9, 105–16.
- Yabuta, N.H., Sawatari, A. and Callaway, E.M. (2001). Two functional channels from primary visual cortex to dorsal visual cortical areas. *Science*, 292, 297–300.
- Yamamoto, I., Yamada, S. and Sato, O. (1985). Unusual craniocerebral penetrating injury by a chopstick. *Surgical Neurology*, 23, 396–8.
- Yeni-Komishian, G.H. and Benson, D.A. (1976). Anatomical study of cerebral asymmetry in the temporal lobe of humans, chimpanzees and rhesus monkeys. *Science*, 192, 387–9.
- Yeudall, L.T. and Fromm-Auch, D. (1979). Neuropsychological impairments in various psychopathological populations. In J. Gruzelier and P. Flor-Henry (eds), *Hemisphere Asymmetries of Function and Psychopathology*. New York: Elsevier.
- Yeudall, L.T., Fromm-Auch, D. and Davies, P. (1982). Neuropsychological impairment of persistent delinquency. *Journal of Nervous and Mental Disease*, 170, 257–65.
- Young, A.W. (1994a). Covert recognition. In M.J. Farah and G. Ratcliff (eds), *The Neuropsychology of High-level Vision*. Hove, UK: Lawrence Erlbaum.
- Young, A.W. (1994b). Progress and neglect. In P.W. Halligan and J.C. Marshall (eds), *Spatial Neglect: Position Papers on Theory and Practice*. Hove, UK: Lawrence Erlbaum.
- Young, A.W., Aggleton, J.P., Hellawell, D.J., Johnson, M., Broks, P. and Hanley, J.R. (1995). Face processing impairments after amygdalotomy. *Brain*, 118, 15–24.
- Young, A.W., Newcombe, F., de Haan, E.H.F., Small, M. and Hay, D.C. (1993). Face perception after brain injury. *Brain*, 116, 941–59.
- Yousem, D.M., Maldjian, J.A., Siddiqi, F., Hummel, T., Alsop, D.C., Geckle, R.J., Bilker, W.B. and Doty, R.L. (1999). Gender effects on odor-stimulated functional magnetic resonance imaging. *Brain Research*, 818, 480–7.
- Yousem, D.M., Williams, S.C.R., Howard, R.O., Andrew, C., Simmons, A., Allin, M., Geckle, R.J., Suskind, D., Bullmore, E.T., Brammer, M.J. and Doty, R.L. (1997). Functional MR imaging during odor stimulation: Preliminary data. *Radiology*, 204, 833–38.
- Yu-Huan, H., Ying-Guan, Q. and Gui-Quing, Z. (1990). Crossed aphasia in Chinese: a clinical survey. *Brain and Language*, 39, 347–56.
- Zaidel, D.W. (1996). Left-sided cradling. Comment on Sieratzki and Woll. *The Lancet*, 348, 691.
- Zaidel, D.W., Aarde, S.M. and Baig, K. (2005). Appearance of symmetry, beauty and health in human faces. *Brain and Cognition*, 57, 261–3.
- Zaidel, D.W., Chen, A.C. and German, C. (1995). She is not a beauty even when she smiles: possible evolutionary basis for a relationship between facial attractiveness and hemispheric specialization. *Neuropsychologia*, 33, 5, 649–55.
- Zaimov, K., Kitov, D. and Kolev, N. (1969). Aphasie chez un peintre. *Encephale*, 58, 377–417.
- Zajonc, R.B. (1980). Feeling and thinking: preferences need no inferences. *American Psychologist*, 35, 151–75.
- Zakzanis, K.K., Leach, L. and Kaplan, E. (1999). *Neuropsychological Differential Diagnosis*. Lisse: Swets and Zeitlinger.
- Zarit, S. and Kahn, R. (1974). Impairment and adaption in chronic disabilities: spatial inattention. *Journal of Nervous and Mental Diseases*, 159, 63.
- Zatorre, R.J., Evans, A.C., Meyer, E. and Gjedde, A. (1992a). Lateralization of phonetic and pitch discrimination in speech processing. *Science*, 256, 846–9.
- Zatorre, R.J., Jones-Gottman, M., Evans, A.C. and Meyer, E. (1992b). Functional localization and lateralization of human olfactory cortex. *Nature*, 360, 339–40.
- Zatorre, R.J., Meyer, E., Gjedde, A. and Evans, A.C. (1996). PET studies of phonetic processing of speech – review, replication and reanalysis. *Cerebral Cortex*, 6, 1, 21–30.
- Zeki, S. (1993). *A Vision of the Brain*. Oxford: Basil Blackwell.
- Zola-Morgan, S., Cohen, N.J. and Squire, L.R. (1983). Recall of remote episodic memory in amnesia. *Neuropsychologia*, 21, 5, 487–500.
- Zola-Morgan, S. and Squire, L.R. (1985). Complementary approaches to the study of memory: human amnesia and animal models. In N.M. Weinberger, J.L. McGaugh and G. Lynch (eds), *Memory Systems of the Brain: Animal and Human Cognitive Processes*. New York: Guilford Press.
- Zoli, M. et al. (2002). Identification of the nicotinic receptor subtypes expressed on dopaminergic terminals in the rat striatum. *Journal of Neuroscience*, 22, 8785–9.
- Zurif, E.B. and Carson, G. (1970). Dyslexia in relation to cerebral dominance and temporal analysis. *Neuropsychologia*, 8, 351–61.

Index

- AA (patient), 440
- ablation, 3, 8, 341, 437
- absence epilepsy, 399
- acalulia, 137
- accidents, handedness and, 160
- acetylcholine, 70, 72, 92, 191, 340, 372
- achromatopsia, 107, 214, 220, 246
- acquired dyslexia, 301–5, 315–16
- action potential, 65–70, 72
- acuity, 214, 382
- Adam (case study), 226
- addiction, 414
- adrenaline, 71, 72
- affect, 346
- affective disorders, 400–19
- afferent projections, 78, 83, 85
- age, recovery and (aphasia), 432–4
- ageing, 365–7, 372, 382–90, 424, 467
- aggregate field view, 8
- aggression, 85, 91, 92, 356, 362–3
- agnosia, 13, 214–35, 366
 - apperceptive, 11, 215–17, 218, 221
 - associative, 11, 215–16, 218–19, 221–2, 223
 - auditory, 212, 214, 215, 234–5
 - Balint's syndrome and, 218
 - category-specific, 222–4
 - classification of, 218
 - colour, 215, 220
 - integrative, 216–17
 - landmark, 38, 233
 - Marr's computational model, 220
 - prosopagnosia, 38, 215, 222, 225–33
 - shape, 216
 - somatosensory, 215, 235
 - sound, 89, 215, 234
 - tactile, 149, 212, 214, 215, 235
 - visual, 94, 212, 214–19, 222–4, 247
- agrammatism, 274, 291
- agraphia, 137, 316–17
- AIDS, 27, 382, 480
- akinesia, 254, 258, 259, 262
- akinetopsia, 107
- alcohol, 380, 415
- alcoholic dementia, 380, 464
- alcoholism, 27, 327, 381, 390
- alexia, 137, 222
- alien hand, 150
- allesthesia/allochiria, 239
- alpha desynchronization, 23
- alpha motor neurons, 118
- alpha wave, 21, 23, 356, 360
- Alzheimer's disease, 27–8, 57, 315, 326, 336, 342, 366–73, 390, 480
 - aetiology of, 373–5
 - age factor, 367, 372, 389
 - brain degeneration, 371–2
 - clinical features, 367–71
 - dementia associated with, 366–73
 - diagnosis, 366
 - genetic factors, 373–4
 - Huntington's disease and, 381
 - Korsakoff's psychosis and, 380–1
 - Lewy body dementia and, 378–9
 - linguistic problems, 369
 - memory and, 367–8, 369, 376, 467
 - neural transplantation and, 268, 270
 - neurochemical features, 372–3
 - olfactory impairment, 375
 - Pick's disease and, 377–8
 - plaques, 366–7, 372, 374–6, 378, 387, 390
 - subcortical dementia and, 379
 - tangles, 366, 372, 374–5, 378
 - treatment of, 375–6
- AM (patient), 201
- ambidexterity, 160
- Ambiguous Angles Test, 457
- amines, 70, 71
- amino acids, 70, 71, 405
- Ammon's horn, 324
- amnesia, 11, 20, 94, 373
 - anterograde, 10, 15–16, 183–4, 326, 327, 329–31, 377, 380, 390
 - impaired recall, 328–9
 - long-term, 332–3
 - malingering, 482–3
 - rehabilitation, 444–7
 - retrograde, 10, 183, 184, 326, 327, 329, 377, 390
- amphetamines, 398
- amygdala, 91–3, 116, 118, 134, 187, 197, 325, 371, 374, 398
 - anxiety and, 408–12, 417, 418
 - emotion and, 347, 348–54, 358, 359
 - face perception and, 230–1, 332–3
- amyloid protein deposits, 372, 376
- anarithmetria, 137–8
- anatomical personology, 7–8
- anatomical reorganization theories, 439
- aneurysm, 100, 182, 184, 268
- anger, 347, 351, 352, 356, 358–9, 362–3
- angina, 415
- angular gyrus, 268, 275, 279, 295, 297, 309
- animal spirits, 2, 6
- anions, 65
- Annett Handedness Questionnaire, 141, 457
- anomalous dominance, 156
- anomia, 14, 149, 151, 219, 235, 369, 432
- anosagnosia, 106, 236
- anoxia, 101
- anterior cerebral artery, 97, 100
- anterior cingulate cortex, 157, 178, 326, 348
- anterior commissure, 145, 146, 151, 154
- anterior spinal artery, 98
- anterior thalamic nucleus, 84, 93

- antero-medial temporal lobe, 116
 anterograde amnesia *see* amnesia
 anterolateral system, 114
 anticholinergic drugs, 257, 261, 389
 antidepressants, 403–7, 413
 antipsychotic drugs, 398
 antisocial behaviour, 205–7
 Anton's syndrome, 106, 216
 anxiety, 27, 346–8, 393, 407–19
 generalized, 401, 407, 413, 415
 Gray's model, 415–19
 OCD, 43, 358, 407, 413, 418, 444
 panic attacks, 407–10, 415, 418–19
 phobias, 401, 407, 408, 411, 418
 PTSD, 43, 407, 408
 treatment of, 413–15
 anxiolytics, 413–15, 417 418
 aphasia, 7, 14, 20, 263, 276, 279–91, 338, 366, 430
 classification, 279, 281
 conduction, 9, 145, 279, 281, 284, 303
 deep dyspasia, 279, 281, 285
 diagnosis, 279
 global, 9, 279, 281, 286, 432, 435
 optic, 215, 219–20
 phenomenology, of 286–9
 production (Broca's), 8–9, 76, 129, 274, 279, 281–5, 291, 432, 435, 441
 recovery, 286, 424, 432–6, 437, 438, 439, 440, 441, 443
 screening test, 457, 461, 469–70
 sensory (Wernicke's), 9, 76, 278, 279, 281–3, 285, 291, 294, 432, 435, 440
 symptoms, 279, 280, 281
 transcortical motor, 279, 281, 285
 apolipoprotein E (APOE), 373–4
 apperceptive agnosia *see* agnosia
 apperceptive mindblindness, 215
 approach–withdrawal model, 359, 360–2
 apraxia, 120, 263–8, 279, 366
 basal ganglia and, 266
 callosal syndromes and, 150, 151, 266
 constructional, 89, 265, 266, 381
 gait, 264, 266
 ideational, 265, 473
 ideomotor, 265, 473
 limb, 264, 266, 473
 localization of, 266–7
 oral, 264, 266, 473
 tests of, 264, 457
 types of, 264–6
 arachnoid mater, 95, 98
 arcuate fasciculus, 267, 284
 arithmetic, 137–8, 144
 arteries (of brain), 97–8
 arteriovenous malformation, 31, 100
 artifact theories, 439
 artists (spatial neglect), 246–8
 assessor–patient interaction, 478
 association areas, 86, 93–4, 381
 associative agnosia *see* agnosia
 associative mindblindness, 215
 astereognosis, 149, 235
 astrocytes (astroglia), 63–4, 377
 asymbolia, 263
 asymmetry *see* lateralization of function; neuroanatomical asymmetry
 AT (patient), 109
 ataxia, 108, 109, 263, 455
 atherosclerosis, 100
 atropine, 70
 attention, 134–6, 180, 245
 tests of, 457, 463, 469
 audition, 45–6, 93, 111–14, 151
 auditory agnosia, 212, 214, 215, 234–5
 auditory cortex, 86, 89, 93, 112, 127–8, 137, 142, 214, 282, 349
 auditory evoked potential, 24
 auditory hallucinations, 43
 auditory oddball, 27–8
 auditory sound agnosia, 89, 215, 234
 auditory system, 111–14, 166
 aura, 399–400
 autism, 191, 192, 279, 480
 autobiographical memory *see* memory
 autonomic nervous system, 56, 85, 206–7
 autoradiography, 12, 30
 autoscapy, 15
 autosomal dominant gene, 259
 AV (patient), 329–30
 Average Impairment Index, 461
 axial akinesia, 254
 axis transformation, 221
 axoaxonic synapse, 59, 60
 axodendritic synapse, 59, 60
 axon, 6, 10, 59–61, 64, 66, 78, 81, 424–5
 axon collaterals, 61, 72
 axon hillock, 59, 67
 axonal membrane, 60
 axosomatic synapse, 59, 60
 azapirones, 413, 414–15

 balance, 85
 Balint's syndrome, 108, 218, 263
 barbiturates, 71, 413, 414
 basal ganglia, 84, 90, 97, 118, 245, 253, 255, 261, 266–8, 286, 358, 418
 basilar artery, 97
 basilar membrane, 111, 112
 behaviour, 175–7, 180–1, 203, 354
 social, 166, 171, 192, 194–201, 204
 behavioural compensation, 439
 behavioural inhibition system, 415–19
 Bell-Magendie law, 7
 Benton Visual Retention Test, 457, 467–9, 476
 benzodiazepines, 71, 413, 414, 418
 beta-blockers, 415
 beta wave, 23
 bilingualism, 276–7
 binocular zone, 103
 biochemical techniques, 39–40
 bipolar depression, 401, 402, 403
 BL (patient), 433–4

- bleeding, arterial, 97
- blind spots, 106, 212–13
- blindness, 106, 212–14, 216
- blindsight, 212–14
- blindtouch, 212
- blood/brain barrier, 373
- blurred vision, 257, 404
- body (of corpus callosum), 146–8
- body temperature, 92
- Boston Diagnostic tests, 457, 469–70
- bouton termineau, 59, 66, 68, 70, 83
- bradykinesia, 254, 260, 268–9, 379
- brain, 2–7
 - arteries of, 97–8
 - blood glucose and, 31–2, 96
 - blood supply to, 97–8
 - development, 423–8, 430
 - electrical activity in, 12, 21–4
 - electrical stimulation, 10–11, 41–5
 - function, 10, 11, 12–51
 - imaging, 12, 29–40, 49–51
 - inflammation of, 64, 101
 - lesioning, 12–13, 16–17
 - malfunctions, 99–101
 - neurophysiology of, 55–73
 - oxygen consumption, 31–2, 37, 39
 - protection of, 95–6
 - regions (connections), 86, 93–4
 - sections/divisions, 78–80
 - surgery, 13, 16–17, 41–2, 100
- brain injury, 155, 440
 - mood and, 400–19
 - single-case study, 3, 12–19, 43, 129
 - symptoms, 171–87
 - thought disorders, 393–400
- brainstem, 5–6, 70, 72, 82–5, 96, 97, 114, 347
- Brixton Spatial Anticipation Test, 171
- Broca-Wernicke-Lichtheim model, 274, 291
- Broca's aphasia *see* production aphasia
- Broca's area, 9–10, 76, 100, 127, 129–30, 143, 157, 165, 191, 195, 223, 274, 275, 279, 283–5, 290, 294, 299, 309
- Brodman's map, 10, 11, 106
- BSE, 374
- buccofacial apraxia, 264, 266, 473

- calcium/calcium channels, 66, 68, 325
- callosal agenesis, 145
- callosal syndromes, 145–54, 266
- callostomy, 145, 149
- Cambridge Contextual Reading Test, 464
- Cambridge Neuropsychological Test Automated Battery (CANTAB), 480
- Camden Memory Test, 457, 466
- cancellation task, 236–7
- carbon monoxide poisoning, 101, 216, 258
- card sorting tasks, 167–8, 171, 176–7, 178, 186, 204, 205, 457, 465
- cardiocentric view, 2
- category-specific visual agnosia, 222–4
- category exemplar generation, 184–5
- category test, 461

- cations, 65
- Cattell's Culture–Fair Test, 187–8
- cauda equina, 82, 83, 96
- caudal (definition), 76
- caudate nucleus, 90, 244, 253, 255, 257, 260, 261, 385, 428
- cell body, 6, 59, 61, 63–4, 70, 92, 323, 424
- cell death, 99, 101, 310, 375, 381
- cell membrane, 57, 59, 65, 66–7, 68
- cell migration, 424
- central agnosia, 215
- central executive (memory), 322, 338
- central motor neurons, 118
- central motor system, 102, 118
- central nervous system, 2–3, 55–73, 80–5, 95, 101, 454–5, 476
- central sulcus, 86
- cephalocentric view, 2, 5
- cerebellum, 84–5, 96, 97, 118, 260, 263, 313–14, 397, 455
- cerebral asymmetry *see* lateralization of function; neuroanatomical asymmetry
- cerebral cortex, 2, 8, 10, 16, 34, 80, 84, 85–92, 114, 347
 - association areas, 86, 93–4
 - asymmetry of, 127–8
 - columns of, 93
 - fissures/sulci, 86
 - hemispheres, 87–8, 127–8
 - layers of, 92
 - limbic system, 91–2
 - lobes of, 86–90
 - movement and, 119–20
 - organization of, 92–4
- cerebral hemispheres, 2, 84, 127–8
- cerebral palsy, 262, 268
- cerebral peduncles, 84
- cerebritis, 101
- cerebrospinal fluid (CSF), 3, 6, 80, 95, 101, 403, 404, 428
- cerebrovascular accident, 99–100, 254, 357, 377, 390, 467, 479
 - amnesia and, 326
 - aphasia and, 279, 286–9, 424, 438
- cervical vertebrae, 81
- chemosensation, 115
- children, 395, 476–8
- chimeric faces, 149–50
- chlordiazepoxide, 414
- chloride ions, 65, 69, 71
- chlorpromazine, 398
- chocolate, 23, 173, 404
- cholesterol, 100
- choline acetyltransferase, 70, 372, 375
- cholinergic axons, 92
- cholinergic neurons, 70, 340, 375
- cholinergic system, 373, 375, 381, 406
- choreiform movement, 259
- choroid plexus, 96
- chromosomes, 259, 260, 367, 396
- cingulate gyrus, 91, 93, 166, 178, 195, 244, 349, 358, 373, 397
- circle of Willis, 97, 100
- cisterns, 95
- classical conditioning, 323, 324–5, 348–9
- closed-head injury, 99, 354, 438
- clozapine, 398

- cocaine, 398, 405
 coccygeal vertebrae, 81
 coccyx, 82
 cochlea, 86, 111, 112
 cognitive ability, 12, 191–2, 374, 376, 382, 389–90, 454, 460, 461–2
 cognitive deficits, 396, 454
 cognitive estimation test, 171
 cognitive flexibility, 175, 259
 cognitive impairment, 400, 445, 456, 460
 cognitive neuropsychology, 2–3, 18–19, 34, 38–9
 cognitive processing, 26, 27, 37
 cognitive rehabilitation, 442–3
 colliculi, 84, 105–6, 112, 135
 colour (visual analysis), 102
 colour agnosia, 215, 220
 colour anomia, 220
 colour blindness, 107, 214, 220, 246
 commissures, 93
 commissurotomy, 16, 145–6, 149–51
 communicative abilities test, 470
 compensation, dyslexia and, 310–11
 compensatory actions, 150
 Complex Figure Test, 467–8
 comprehension, 89, 274–6, 279, 284, 457
 computational modelling, 20–1
 computer-assisted therapy, 443
 computer-based assessment, 480–1
 computerized tomography, 12, 30–1, 402
 concept formation, 457, 465
 conditioning
 classical, 323, 324–5, 348–9
 fear, 20, 325, 341, 348–54
 conduction aphasia *see* aphasia
 connectionism, 20–1
 consciousness, loss of, 100
 constructional apraxia *see* apraxia
 contention scheduling, 202
 Continuous Performance Test, 178, 457, 469, 477
 Continuous Recognition Memory Test, 467
 Continuous Visual Memory Test, 467
 contralateral (definition), 78
 Controlled Oral Word Association, 167
 convergence zones, 115, 151, 220
 copper metabolism, 262
 coprolalia, 261, 262
 corollary discharge, impaired, 172
 coronal section, 78–9
 corpus callosum, 6, 16, 84, 145–54
 corpus striatum, 6
 cortex *see* cerebral cortex
 cortical blindness, 106
 corticocortical connections, 93, 349
 corticospinal tract, 83–4, 118
 cradling, 431
 cranial nerves, 83, 84, 94–5, 112, 114, 118, 455
 Creutzfeldt–Jakob disease, 374, 382, 390
 cross-cueing, 150
 crossed aphasia, 437
 crowding hypothesis, 142, 155, 440
 crus cerebri, 84
 crystallized intelligence, 187, 188, 389
 curare, 70
 cycad seeds, 258
 cytoarchitecture, 10, 11, 92, 128
 cytoplasm, 382
 DB (patient), 213
 deaf hearing, 212
 deafness, 89, 112, 298–9
 decision making, 166, 188–90
 declarative memory *see* memory
 deep dysgraphia, 317
 deep dyslexia, 20, 301, 302–5, 315–17
 deep dysphasia, 279, 281, 285
 degenerative disorders, 27–8, 39, 120, 253–60
 delayed-response task, 186–7
 delta wave, 23
 delusions, 394, 395, 398
 dementia, 72, 101, 279, 336, 365–90
 ageing and, 365–6, 382–90
 alcoholic, 380, 464
 of Alzheimer type, 366–73, 387–9, 464
 diagnosis, 365–6
 fronto-temporal lobe, 378
 Huntington's disease, 40, 120, 254, 259–60, 358, 379, 381, 385, 390, 397
 infection and, 381–2
 Korsakoff's disease, 27, 40, 327, 380–1, 390
 Lewy body, 378–9
 Parkinson's disease, 21, 40, 120, 254–9, 262, 358, 379, 390, 464, 467, 480
 Pick complex, 377–8, 390
 subcortical, 379
 vascular, 376–7
 viral, 381
 dendate gyrus, 323–4, 325
 dendrite, 6, 21, 59, 61, 62, 63, 83
 formation, 424, 425
 dendritic spines, 59
 depolarization, 66–7, 68, 69
 depression, 27, 40, 43, 49, 348, 354, 360, 379, 393, 401–7, 456, 464, 479
 bipolar, 401, 402, 403
 ECT and, 404
 genetic influence, 402
 hypotheses of, 406–7
 neurochemistry of, 403–4
 neuropathology of, 402–3
 symptoms, 401–2
 treatment of, 404–6
 types of, 401
 unipolar, 401, 402, 403, 404
 desynchronization, 23
 development of function, 423–37
 asymmetry and, 430–1, 432–5, 436–7
 environment and brain development, 429
 language and, 435, 440
 neural characteristics, 424–7
 neuroimaging and, 431–2
 structural development, 428

- developmental amnesia, 329–30
 developmental dyscalculia, 138
 developmental dyslexia, 37, 243, 301, 305–8, 310–11, 313–14
 DF (patient), 109
 diaschisis, 439
 diathesis model, 360
 diazepam, 414
 dichotic listening, 45, 311, 430
 diencephalon, 80, 83–5, 326–9, 380
 disconnection syndromes, 145, 267
 see also callosal syndromes
 disgust, 347, 351, 356, 358–9, 400
 dissociated functions, 18
 divided attention, 134, 135
 donepezil, 375–6
 dopamine, 72, 187, 258–60, 262, 268–70, 385, 403
 receptors, 71, 255–7, 397, 398
 dorsal (definition), 76
 dorsal column (spinal cord), 84, 114, 115
 dorsal horn, 83
 dorsal visual processing stream, 137
 dorso-lateral prefrontal cortex *see* frontal lobe/cortex
 dot localization task, 472, 483
 double dissociation, 18
 DR (patient), 154
 drawing, 219, 237–9
 dual-route model, 314–15
 dual-task methods, 135, 171, 369
 Duchenne smile, 356
 dura mater, 95–6, 98
 dural sac, 96
 dysexecutive syndrome, 171, 186
 dysgraphia, 279, 316–17, 433
 dyskinesia, 120, 256, 261
 dyslexia, 29, 49, 156, 279, 301–16, 464
 acquired, 301–5, 315–16
 deep, 20, 301, 302–5, 315–16, 317
 developmental, 37, 243, 301, 305–7, 308, 310–11, 313–14
 functional disconnection, 309–10
 neuroimaging and, 307–9, 315–16
 phonological, 29, 301, 302, 305, 314–16
 surface, 20, 301, 302, 316, 378
 visual work form, 301–2
 dysphasia, 279
 dystonia, 261, 262

 echolalia, 261
 Edinburgh Handedness Inventory, 457
 education levels, 475
Edwin Smith Surgical Papyrus, 3–4
 efferent projections, 78, 83, 85
 electrical stimulation, 10–11, 41–5
 electroconvulsive therapy, 336, 404, 405
 electrodes, 21–3, 41, 93
 electroencephalography (EEG), 11–12, 21–4, 45, 192, 378
 depression and, 404
 emotion and, 335, 342
 humour and, 357
 IQ and, 188
 language and, 311
 memory and, 335, 342
 in musicians, 136
 schizophrenia and, 399, 400
 electrostatic pressure, 65
 electrotonic impulse, 67
 elimination hypothesis, 158
 embolism, 99
 emotion, 37, 72, 92, 94, 190
 amygdala and, 347, 348–54, 358, 359
 appraisal and, 346
 approach–withdrawal, 359, 360–2
 basic, 346–7
 behaviourism and, 346
 brain damage and, 355–6, 357
 clinical disorders, 400–19
 definition, 345–7
 diathesis model, 360
 EEG studies, 356, 360–2
 experience of, 356–7, 358–9
 facial expression, 225, 347, 351, 355, 358, 359
 frontal lobes and, 354
 hemispheric asymmetry and, 355–9
 hippocampal system and, 347–8
 humour and, 357–8
 neuropsychological models, 359–63
 normal aspects, 345–63, 400–1
 OFC, 197, 198, 203–4, 346–7, 354–5
 Papez circuit, 348–9
 perception of, 355–6
 psychopathology of, 400–19
 psychopathy, and 203–7
 smiling, 356
 subcortical structures and, 347–54
 encephalitis, 101
 encephalomyelitis, 101, 382
 encephalopathy, 101, 382
 encoding, 181–4, 186, 321, 333–7, 342–3, 386, 387
 endolymph, 112
 entorhinal cortex, 323, 324, 347, 372
 epilepsy, 10, 16, 41, 69, 143, 145–6, 189, 224, 437, 440, 445
 absence (*petit mal*), 399
 causes, 398–9
 generalized, 399, 400
 idiopathic, 398
 L-dopa and, 257
 memory and, 330–1, 332–3, 400, 446
 partial (focal), 399–400
 tonic-clonic (*grand mal*), 399, 400
 epinephrine, 71, 72
 episodic memory *see* memory
 equipotentiality, 8, 430, 436, 438
 event-based experiments, 180
 event-related potentials, 24–30, 33, 132
 amplitude, 24–5
 face recognition and, 230
 language and, 275–7, 311–12, 431
 EVR (patient), 175–7, 180, 196, 198, 200, 204, 205
 excitatory postsynaptic potential, 68–9
 executive function, 165, 178, 186, 254, 379, 385

- exocytosis, 68
 explicit memory *see* memory
 expressive aphasia *see* production aphasia
 external auditory meatus, 112
 extracellular fluid, 59, 63, 65, 67, 68, 72, 96
 extrapyramidal system, 101, 118, 254
 extrastriate cortex, 94, 107, 130, 157, 233, 297, 308
 extroversion, 197
 eye, 45, 102–5, 165, 244, 262

 5-HT *see* serotonin
 face recognition, 20, 34, 37, 92, 132, 222, 225–9, 340, 372, 457, 471
 amygdala and, 230–1, 332–3
 impairments in, 225–33
 facial asymmetry, 126–7
 facial expression, 132, 197, 198, 231–2, 396, 411, 431, 455
 emotion and, 225, 347, 351, 355, 358–9
 false-belief task, 192, 193
 familial sinistrality (FS), 142–3
 FAS Verbal Fluency Test, 464
 Fast Fourier Transform, 23
 Faux Pas Test, 201
 fear, 346, 347, 356, 417
 conditioning, 20, 325–6, 341, 348–54
 feedback loops, 72, 93, 106
 feeding, 85, 91, 114–18
 fenestra cochleae/vestibuli, 111
 finger tapping, 266, 461
 fissures, 83, 86, 95, 127, 128
 fixation spot, 46, 47, 48, 149, 236
 flashbulb memory, 368
 flavour, 114–18, 172, 174
 Florida tests, 457, 473
 fluid intelligence, 187, 188, 322
 fluoxetine, 405
 focal attention, 135
 folia, 85
 food, 23, 172–3, 174–5
 forebrain, 80
 form, visual analysis, 102, 107
 fornix, 85, 324, 327, 348
 fractionation hypothesis, 18–19
 free recall, 181, 254, 323, 340, 383–4
 freezing response, 254, 349, 350
 Friedrich's ataxia, 263
 frontal eye fields, 105, 135, 165, 244
 frontal lobe/cortex, 427, 464, 465
 abstract reasoning, 166, 167, 190–1
 anatomy of, 165–6
 anxiety and, 413, 418
 apraxia and, 267
 attention and, 180
 cognitive symptoms, 175–87
 convergence zones, 115, 151, 220
 corollary discharge, 172
 decision making, 188–90
 dementia, 371–2, 377–8
 depression and, 402
 emotion and, 346, 354–5, 357–8, 363
 EVR (patient), 175–7
 functions, 164–5, 166–71
 geography of, 163–4
 intelligence and, 166–7, 180, 187–8
 language and, 274–5, 277, 278, 285, 296–7, 308, 309–10
 memory and, 180–2, 184–8, 193–4, 337
 motor symptoms, 172
 neglect and, 239
 olfactory function, 173–4
 personality, 171, 194–201
 planning and, 172, 175–80
 prefrontal cortex, 94, 119, 131, 136, 165–6, 171, 175–87
 processing speed, 385–6
 psychopathy, 204–7
 reward and, 189, 197, 203, 204
 schizophrenia and, 397–8
 sensory/perceptual symptoms, 172–4
 sequencing and, 178–9
 social behaviour, 166, 171, 192, 194–201, 204
 spontaneous behaviour, 175–7
 syndrome/symptoms, 171–87
 tests of function, 167–71, 175
 theories, 191–4, 201–4
 utilization behaviour and, 180–1, 203
 working memory and, 178, 181–2, 186–8, 191, 203
 frontal lobotomy, 354
 frontal operculum, 76, 115, 348
 fronto-temporal dementia, 377, 378, 390
 frontosubcortical dementia, 379, 390
 functional adaptation theories, 439, 442
 functional disconnection, 309–10
 functional disorganization, 16
 functional localization *see* localization of function
 functional magnetic resonance imaging, 12, 31, 37–39, 50–1, 113–14, 137, 153, 397, 408, 411
 brain development, 428, 430–1, 434, 440
 emotion, 348, 352, 358
 frontal lobes, 179, 181, 184–5
 memory, 333, 338
 functional maps, 10, 11
 functional validation, 429
 fusiform face area, 37, 133, 228–9
 fusiform gyrus, 220, 224, 227–8, 275, 295, 309

 GABA, 71, 255, 259, 398, 404, 413, 418
 Gage, Phineas, 13, 166, 194–6, 199, 203–4, 354
 gait apraxia, 264, 266
 gait ataxia, 263, 455
 galantamine, 375
 galvanic skin response, 206, 230
 gamma-aminobutyric acid *see* GABA
 gamma motor neurons, 118
 gamma radiation, 33, 34
 ganglion, 61
 ganglion cells, 102, 105
 generalized anxiety disorders, 401, 407, 413, 415
 generativity, 155
 genetics, 260, 396, 402
 Genie, 448–9
 genu, 146, 147, 151

- Gerstmann–Straussler syndrome, 374
 Geschwind–Galaburda model, 156–7
 gestures, 143
 Gilles de la Tourette syndrome, 254, 261–2, 358
 glial cells, 56, 60–1, 63–5, 80, 403, 424
 global aphasia, 9, 279, 281, 286, 432, 435
 global attention, 135
 global processing, 156, 217
 globus pallidus, 90, 92, 253, 255, 259, 260, 261, 262, 428
 glutamate, 71, 398
 glycine, 71
 go/no go task, 205
 goal neglect, 179
 Golgi cells/stains, 6
 GR (patient), 303–5
 grafting, 268–70
grand mal, 399, 400
 granulovacuolar degeneration, 372, 390
 grapheme–phoneme correspondence rules, 20, 277–8, 297, 302, 304, 317, 463–4
 grasping, 93, 107–9, 118, 431
 Gray's model (anxiety), 415–19
 grey matter, 63, 83–5, 101, 397, 428
 growth spurts, 423–4
 GT (patient), 193–4
 Guam (island), 258
 gustatory system, 114–16, 172–3
 GY (patient), 214
 gyri, 7, 9, 44, 86, 127, 137
- haemorrhage, 99–100, 432
 haemorrhagic strokes, 100
 hallucinations, 43, 394–5, 397, 398
 Halstead–Reitan Battery, 456–7, 458, 460–1, 469–70, 477, 481
 Halstead–Reitan Category Test, 457, 482
 hand cramps, 261
 hand movement, 120, 150, 172, 263, 266
 handedness, 125, 148, 156–7
 - emotion and, 356
 - IQ and, 142, 144
 - language and, 143
 - lateralization and, 129, 133, 141–4, 158–60
 - measurement of, 141–2
 - mortality and, 158–60
 - recovery and, 435
 - sex and, 138, 140
 - tests, 141, 457*see also* left handedness; right handedness
- happiness, 43, 346–7, 351, 354, 356, 400
 Hare Psychopathy Checklist, 206–7
 head movement, 261, 438
 headache, 100, 101, 404
 hearing, 45–6, 93, 111–14, 151
 heart, 2
 heart rate, 56, 357, 415
 hemiballisms, 455
 hemidecortication, 437
 hemiparesis, 120
 hemiplegia, 268, 437
 hemiretina, 103–4
- hemispherectomy, 430–1, 433, 440, 444
 hemispheres, 2, 84, 127–8
 - see also* left hemisphere; right hemisphere
 hemispheric asymmetry *see* lateralization of function
 hemispheric compensation, 433, 439–41
 hepatolenticular degeneration, 120, 254, 262
 HERA model, 186, 342–3
 herpes simplex, 223, 381
 Heschl's gyrus, 89, 113, 127, 279, 282
 heterozygotes, 144
 HG (patient), 217
 hiccup, 262
 hindbrain, 80
 hippocampus, 57, 91–2, 134, 146, 191, 224, 324–5, 329–31, 333, 341–2, 347–9, 372, 374–5, 381, 396–7
 Hirano bodies, 372, 390
 histamine, 71, 415
 HIV, 382
 HJ (patient), 441
 HJA (patient), 13, 216–17, 219, 222
 HM (patient), 13, 16, 330–1
 homonymous hemianopia, 106, 219
 Homonopheme Meaning Generation Test, 464
 homozygotes, 144
 homunculus, 41–2
 horizontal section, 78–9, 80
 hospital plan task, 169–70
 humour, 357–8
 Huntington's disease, 39, 120, 254, 358, 379, 385, 390, 397
 - aetiology, 260
 - Alzheimer's disease and, 381
 - clinical features, 259–60
 - genetic testing, 260
 - neuropathology, 260
 - treatment, 260
 hydrocephalus, 101, 254
 hydrogen nuclei, 35
 hydroxine, 415
 hyperpolarization, 66–7, 71
 hypertension, 100, 404, 406
 hypokinesia, 245, 254
 hypometabolism, 327
 hyposmia, 174
 hypothalamus, 84, 85, 91, 92, 326–7, 348, 354, 412
 hypothesis-testing strategy approach, 17
 hypoxia, 395
- ideational apraxia, 265, 473
 ideomotor apraxia, 265, 473
 idiopathic epilepsy, 398
 IM (patient), 369–71
 imagery, 133–4, 239, 240
 imaging techniques, 12, 19–39, 49–51
 implicit memory *see* memory
 incus, 111, 112
 independent-systems theory, 222
 individual differences, 19, 129, 138–44
 infarction, 99
 inferior colliculi, 84, 112
 inferior temporal cortex, 94, 108

- inhibitory postsynaptic potential, 69
insula, 86, 115, 134, 173, 245, 291, 309, 387, 411
integrative agnosia, 216–17
intelligence, 17, 366
 crystallized, 187, 188, 389
 fluid, 187, 188, 322
 frontal lobes and, 166–7, 180, 187–8
 premorbid, 17, 438, 457, 458, 462–5
 tests, 138, 142, 187, 444, 456–60, 469
interference, 181
intermanual conflict, 150
internal capsule, 84, 90, 97, 114
internal carotid artery, 97, 100
internal medullary lamina, 84
interneuron, 61, 62, 71
intracellular fluid, 59, 65
intracerebral haemorrhage, 100
invariance hypothesis, 437
invasive techniques, 16–17, 31–3, 129
involuntary movement, 40, 118, 120, 254, 259–60, 262–3, 455
ions, 65–6, 68
Iowa Gambling Task, 188–9
iproniazid, 404, 406
ipsilateral (definition), 78
IQ, 17, 142, 144, 167, 171, 176, 187–8, 192, 322, 328, 336, 373, 382, 428, 433, 462
 performance, 436, 437, 459–60, 464
 verbal, 436, 437, 457, 459–60, 464
ischaemia, 99
ischaemic stroke, 100
- Jamie (patient), 444
jargon, 282, 432
JB (patient), 181, 182–4, 338–40
JBR (patient), 222, 224
JC (patient), 446–7
JL (patient), 332–3
jokes, 25–6, 357
journals, 485–8
JS (patient), 206
Julia C (patient), 446–7
JW (patient), 150, 154
- Kaplan–Baycrest Assessment, 461–2
Kayser–Fleischer ring, 262
Kennard principle, 436
Klüver–Bucy syndrome, 348
Koh's Block Design Task, 178
Korsakoff's psychosis/disease, 27, 40, 327, 380–1, 390
- L-dopa, 255–7, 258, 259, 268
L-tryptophan, 405
landmark agnosia, 37, 233
language, 127–8, 300, 397
 bilingualism, 276–7
 critical period, 428, 430–4, 448–9
 deafness and, 298–9
 development, 155, 428, 430–4, 448–9
 disorders, 37, 279–91, 301–17, 443–4, 448–9
 ERP and, 275–7, 311–12
 function, 33, 292–4, 435–6, 469–70
 handedness and, 143, 266
 lateralization, 9, 124, 129–31, 140–3, 274–6
 neuroanatomy of, 49–51
 production, 274, 276–9, 284
 tests, 12, 38–41
 see also comprehension; dyslexia; reading; writing
lateral (definition), 76
lateral eye movement (LEM), 45
lateral fissure, 86
lateral geniculate body, 84, 93
lateral geniculate nucleus, 103, 104–5
lateral lemniscus, 112
lateral thalamic nucleus, 84, 114
lateral ventricles, 96
lateralization of function, 124–61, 178
 anomalous dominance and, 156
 attention, 134–6
 callosal syndromes, 145–54
 development of, 423–37
 emotion and, 355–9
 expectations (theories), 154–7
 Geschwind–Galaburda model, 156–7
 handedness and, 129, 133, 141–4, 158–60
 in humans, 125–8
 imagery, 133–4
 individual differences, 129, 138–44
 language, 9, 124, 129–31, 140–3, 274–6
 mathematical ability, 137–8
 memory processes, 342–3
 perception of music, 136–7
 sex and, 138–41
 visuospatial ability, 131–3
LB (patient), 153–4
learning, 323–5, 341, 400
left handedness, 142–3, 156–60, 435
left hemisphere, 127, 128, 135–8
 development of, 156, 310, 430–1
 emotion and, 355–6, 357, 359–61
 interhemispheric transfer, 150–4
 language and, 129–31, 140–1, 143, 154, 155, 266, 274, 275–6, 277, 310
 memory and, 333, 335, 337
 visuospatial ability and, 131, 133
 see also lateralization of function
lentiform nucleus, 90
Lewy bodies, 255, 378–9, 390
lexical decision task, 130, 157, 275, 292, 441
Librium, 414
limb apraxia, 264, 266, 473
limb movement, 150, 262, 473
limb position, 114
limbic system, 91–2, 166, 347, 348, 354
line bisection, 236, 237
line orientation test, 472
literacy, 305–6
localization of function, 2, 5–6, 7–8, 9–10, 40, 47–8, 124, 211
locus coeruleus, 72, 255, 371, 378, 390, 412, 417
long-term memory *see* memory
long-term potentiation, 323–4, 325–6

- lumbar puncture, 96
 lumbar vertebrae, 81, 82
 Luria–Nebraska Neuropsychological Battery, 456, 461, 477
 Luria's theory, 13–14, 201–2
- magnetic field, 29, 37, 42–4
 magnetic resonance imaging *see* functional magnetic resonance imaging
 magnetoencephalography (MEG), 29–30
 magnocellular pathways, 104–5, 107, 306
 malingering, 479, 481–3
 malleus, 111
 mammillary bodies, 16, 85, 91, 93, 324, 326–7
 mamillothalamic tract, 85
 mania, 39, 43–4, 396, 401, 405
 maprotiline, 405
 Marr's computational model, 220
 mass action, 438
 mathematical ability, 137–8
 maturation hypothesis, 437
 MD (patient), 376
 medial (definition), 76
 medial geniculate body, 84, 93, 112
 medial lemniscus, 84, 114, 115
 medial thalamic nuclei, 84, 115, 326–7
 medulla, 10, 112, 115
 medulla oblongata, 83–4, 97, 114, 118
 medullary conus, 82
 membrane potential, 65–6, 68
 memory, 5, 20, 72, 86, 99, 254, 259, 380
 ageing and, 383–5, 467
 Alzheimer's disease, 367–9, 376, 467
 declarative, 321–2, 329, 380, 382, 384
 definitions, 321–3
 diencephalon, 80, 83, 84–5, 326–8
 in dyslexia, 305–6
 episodic/autobiographical, 186, 322, 329–30, 332–6, 367–8, 372, 378, 381
 explicit, 184–5, 321, 329, 367, 388
 frontal lobe, 180–2, 184–8, 193–4, 337
 implicit, 184–5, 322, 331, 367, 388
 long-term, 321, 323–6, 329–33, 338, 366–8, 380
 procedural, 321, 322, 445
 prospective, 180, 385, 467
 rehabilitation of, 444–7
 semantic, 322, 329–30, 333–6, 368, 381
 short-term, 181, 239, 275, 321–3, 329–31, 338–40, 366, 368
 temporal lobes, 327, 330–1, 335–6, 400
 tests, 40, 457, 465–9
 working, 178, 181–2, 186–8, 191, 203, 239, 322, 337–41, 348, 368–9, 378, 382, 385–6, 397, 400, 431 *see also* amnesia; recognition
 meninges, 95, 99
 mental rotation, 23, 124, 131–3, 138, 140, 205, 431
 mesencephalon, 72, 83, 84, 97
 metacontrol, 151–2
 metamemory, 384
 metaphors, 130–1, 300, 357
 microdysgenesis, 310
 microelectrodes, 21
 microglial cells, 64
 midbrain, 80, 84, 106
 middle cerebellar peduncle, 84, 85
 middle cerebral artery, 97, 99–100, 268, 432
 milk encephalopathy, 374
 Mill Hill Vocabulary Scale, 457
 miming, 264, 265, 473
 Mini Mental State Examination, 462–3, 475
 MJ (patient), 441
 modification hypothesis, 158
 Modified Vygotsky Concept Formation Test, 168
 modularity, 124, 230
 monoamine oxidase, 404–5, 406–7
 monoamine oxidase inhibitors, 404–5, 406
 monoamines, 71, 258, 403–5, 406–7
 monocular blindness, 106, 429
 monocular zone, 103
 mood, 43, 346, 354
 disorders, 400–19
 morphology, 277, 313
 motor aphasia *see* production aphasia
 motor homunculus, 41–2
 motor neuron damage, 120, 262
 motor system, 118–20
 balance/posture, 85
 disorders, 72, 172, 253–71
 motor cortex, 86, 89–90, 120, 157, 165
 primary motor cortex, 41, 118–20, 166
 supplementary motor cortex, 119–20, 157, 165–6, 172, 178, 195
 movement, 72, 102, 107–9, 172, 253–71
 see also involuntary movement; voluntary movement
 MP (patient), 109–11
 MPTP, 258, 269
 multi-infarct dementia, 27, 376–7, 390
 Multilingual Aphasia Examination, 167, 457, 469
 Multiple Errands Task, 168–9, 179, 187, 200
 multiple sclerosis, 262, 480
 muscle, 84, 118–20
 music, 136–7, 234–5, 292, 361, 376
 musical agnosia, 89
 mutism, 148, 285
 myalgic encephalomyelitis (ME), 101
 myelin, 60–1, 262, 424, 426–7
 myelin sheath, 60
 myelination, 60–1, 63–4, 67, 424, 426–8
 myoclonus, 262
- NA (patient), 14–16, 328
 nasal hemiretina, 103–4
 nasal infection, 375
 National Adult Reading Test, 457, 463–5
 navigation skills, 140
 neglect *see* spatial neglect
 neocortex *see* cerebral cortex
 neostriatum, 16
 nerve, 61
 nerve impulse, 56–7, 59–60, 63, 65–7
 nervous system, 10, 76–7
 cells in, 56–69
 development of, 423–7
 divisions of, 55–6

- neural Darwinism, 424
neural networks, 20–1
neural transplantation, 258, 268–70
neural tubes, 80
neuroanatomical asymmetry, 127–8
neuroblasts, 80
neurochemistry (role), 191
neuroepithelial cells, 80
neurofibrillary tangles, 372, 378–9, 387, 390
neuroimaging, 12, 31, 34, 38–40, 44, 49–51, 90, 120, 129, 133–4, 143, 156–7, 181, 431–2, 440
 dyslexia and, 307–9, 315–16
neurological examination, 454–6
neuron doctrine, 7
neurons, 6–7, 20, 31, 37, 40, 56–63, 72, 80, 92
 communication by, 56, 65–9
 excitability, 65, 68
 growth of, 424, 427
 types of, 61–3
neuropeptides, 70, 96
neuropsychological assessment, 12, 453–84
 approaches, 456–8
 computer-based, 480–1
 history of, 454–6
 individual tests, 462–5
 language function tests, 469–70
 memory tests, 465–9
 practical issues, 473–81
 test batteries, 456–62, 470
 visuospatial ability, 470–2
neuropsychology
 definitions, 2–3
 history/development, 3–12
 techniques/tools, 12–51
Neuropsychology Central, 489
neuroticism, 197, 198
neurotransmission, 68–72
neurotransmitters, 7, 40, 59, 63, 65–6, 68–72, 96, 187, 325, 372–3, 375, 398, 403
NG (patient), 149–50, 153
nicotine, 257–8
nicotinic receptors, 70, 258
NM (patient), 180, 198–201
NMDA system, 325, 398
nodes of Ranvier, 60, 61, 67
non-invasive techniques, 21–9, 32, 35, 36–40, 45–9, 129
noradrenergic receptors, 406–7
norepinephrine, 71–2, 245, 373, 403, 405
NT (patient), 243
nuclear magnetic resonance imaging *see* functional magnetic resonance imaging
nuclei, 61, 72, 83
nucleus basalis of Meynert, 72, 92, 371, 372–3, 378, 390
nucleus of diagonal band of Broca, 92
nystagmus, 106
object detection (search), 109–11
object manipulation, 93–4, 107–10, 133–4
object recognition, 94, 109, 218–22, 263
 see also agnosia
obsessive-compulsive disorder, 43, 358, 407, 413, 418, 444
occipital lobe, 11, 31, 86, 106, 127, 219, 359, 428
odour, 23, 89, 117–18, 149, 173–4
oedema, 99, 432, 439
off-centre cells, 102
olfaction, 23, 29, 86, 89, 91, 173–4
olfactory bulbs, 21, 117, 348, 375
olfactory nerve, 83
olfactory system, 91, 117–18, 149, 173
oligodendroglia/oligodendrocytes, 61, 64
on-centre cells, 102
ophthalmic artery, 97
optic aphasia, 215, 219–20
optic ataxia, 108, 109, 263
optic chiasm, 46, 102, 103, 106, 146, 220
optic disk, 102
optic nerve, 84–5, 102, 106, 220, 455
optic radiation, 106
optic tract, 85, 103, 104
oral apraxia, 264, 266, 473
orbitofrontal cortex, 16, 89, 115, 118, 173, 189, 261, 358–9, 385, 397, 412
 emotion and, 197–8, 203–4, 346, 354–5
 personality and, 175–7, 194–201
 social behaviour and, 194–201, 204
 see also frontal lobe/cortex; prefrontal cortex
organ of Corti, 111, 112
orgasm, 262
orientation, 107–9, 463
orthography, 277, 278, 296, 317
ossicles, 111
oval window, 111–12
oxygen, 31–3, 39
P200, 275, 311
P300, 24, 26–8, 132, 276, 311
Paced Auditory Serial Addition Test, 457, 464, 469
pain, 114
palate, 114
palilalia, 261
pallidotomy, 257
Pallidum, 127
panic, 407–10, 415, 418–19
Papez circuit, 348, 349
parahippocampal gyrus, 92, 134, 227, 233, 342, 387, 397, 408, 415–16
parahippocampal place area, 133, 228, 233
paralexias, 301
parallel-development hypothesis, 437
parallel processing, 20
paralysis, 86, 93–4, 118, 119, 262
paranoia, 39, 371
paraplegia, 262
paraquat, 258
parietal lobe, 86, 89–90, 93–4, 96, 100, 107–9, 114, 120, 131, 172, 266–7, 283, 297, 337, 348, 359, 372, 396
Parinaud's syndrome, 15
Parkinson's disease, 21, 39, 120, 254–9, 262, 358, 379, 390, 464, 467, 480
 aetiology, 258–9
 clinical features, 254–5

- Parkinson's disease (*continued*)
 genetics and, 258
 incidence of, 254–5
 L-dopa and, 255–7, 258
 neural transplants, 257, 268–70
 neuropathology of, 255
 neurotransmission, 255
 treatment of, 256–8
- parkinsonism, 254–9, 262
- parvocellular pathways, 104, 107, 115, 306
- passive listening, 300
- patient compliance, 479
- peduncles, 84, 85, 96
- Pegboard task, 457
- penetrating head injury, 99
- peptides, 70
- perception, 5, 133–4, 155, 172–4
 disorders, 211–49
- perforant path, 324
- performance IQ, 436, 437, 459–60, 464
- periaqueductal grey substance, 84, 417–19
- perikaryon *see* cell body
- perilymph, 112
- peripheral motor system, 102, 118
- peripheral nervous system, 55–73, 82, 94
- permeability, 65–6
- perseverative errors, 167
- personality, 37, 83, 89, 171, 175–7, 194–201, 259, 348, 354, 377, 435, 479
- Peter (patient), 477–8
- petit mal*, 399
- phagocytosis, 63, 64
- pharynx, 114
- phenelzine, 404, 405
- phobias, 401, 407, 408, 411, 418
- phoneme, 261, 275, 291, 292
 correspondence rules, 20, 277–8, 297, 302, 304, 317, 463–4
- phonological awareness, 305
- phonological dysgraphia, 316–17
- phonological dyslexia, 29, 301, 305, 314–16
- phonological loop, 186, 322, 338
- phonological memory, 44, 305–6, 338–40
- phonological processing, 44, 275, 305, 307, 310–11, 316, 356
- phrenology, 7–8
- physical asymmetry, 126–7
- physostigmine, 340, 373
- pia mater, 95
- Pick Complex/Pick's disease, 377–8, 390
- picture tests, 184–5, 308, 466
- pillar cells, 112
- pineal gland, 2, 5–6
- pituitary gland, 85
- planning, 120, 172, 175–80, 193–4
- planum temporale, 127–8, 136, 279, 282, 307, 310, 397–8
- PO (patient), 335–6, 400
- polioencephalitis, 101
- poliomyelitis, 262
- polygraph, 22
- pons, 10, 83, 84–5, 97, 112
- pontine nuclei, 84, 105
- Porteus Maze Test, 178, 457, 465
- positional terms, 76–80
- positron emission topography (PET), 31–5, 39, 50–1, 136, 224, 269, 397, 413
 frontal lobe and, 173, 177–8, 188–9, 193, 202
 language and, 130, 278, 300, 307
 memory and, 327, 328, 333, 335, 338
- positrons, 31
- post-infectious encephalomyelitis, 382
- post-traumatic stress disorder, 43, 407–8
- postcentral gyrus, 86, 100, 235
- posterior cerebral artery, 97, 100
- posterior communicating artery, 97
- posterior parietal cortex, 93, 107–8, 120, 131–2, 135
- posterior spinal artery, 98
- postsynaptic neurons, 59, 68, 70, 71, 73, 255, 323–4, 403–4
- posture, 85
- potassium ions, 63, 65–7, 68, 69, 71
- praxicons, 267–8
- precentral gyrus, 41, 86, 100, 114, 118
- precesses, 35
- prefrontal cortex, 94, 119, 131, 135, 165–6, 171, 175–6, 396–7, 402–3, 425
 anxiety and, 411, 412, 418
 callosal syndromes, 146–7
 cognition and, 177–80
 emotion and, 204, 349, 354
 memory and, 186–7, 326, 333, 335
 psychopathy and, 205–6
- premorbid intelligence *see* intelligence
- premotor area, 93–4, 119, 120, 157, 165
- prepulse inhibition, 396
- presynaptic neurons, 59, 68, 70–1, 403
- pretectum, 105–6
- priaprism, 4
- primary memory, 321
- primary motor area/cortex, 41, 118–20, 166
- primary olfactory cortex, 117
- primary taste cortex, 115, 172–3, 174
- primary temporal cortex, 94
- primary visual cortex, 76, 86, 106–7, 108, 157, 214
- prions, 382
- procedural memory, 321, 322, 445
- production aphasia *see* aphasia
- programmed cell death, 310
- progressive supranuclear palsy, 379, 390
- projection maps, 10
- projection neurons, 61
- promoting aphasics' communicative effectiveness (PACE), 443
- propranolol, 415
- proprioception, 114
- propriospinal fibres, 83
- prosopagnosia, 37, 215, 222, 225–33
- prospective memory, 180, 385, 467
- protons, 35
- pruning, 424, 425
- pseudowords, 275, 296–7, 302, 308, 315
- psychopathy, 204–7
- psychopharmacology, 7
- psychosurgery, 16
- public memory, 368

- pulvinar, 84, 244
punishment, 189, 204, 348, 359
pupillary reflex, 105–6
pure word deafness, 215, 234, 292
putamen, 90, 245, 253, 255, 257, 261, 267–70, 358, 385, 428
PV (patient), 338–40
pyramidal cells, 21, 92, 118, 372
pyramidal decussation, 84
pyramidal tract, 83–4, 118, 120
- quadrantic anopia, 106
quadriplegia, 4, 262
quanta, 68
- radiation, 30, 32, 34, 35, 114
Randt Memory Test, 457, 466
raphe nuclei, 72, 255, 371, 390
Raven's Progressive Matrices, 457, 471
reaching, 107–9
reading, 130, 137, 144, 275–6, 278, 400
 dyslexia, 301–16
 normal, 295–300
reading by ear, 302
reasoning, 5, 166–7, 190–1, 457, 465
recall, 181, 254, 321, 323, 328–9, 340, 387, 463
receptive amusia, 234–5
receptive field, 93, 102
recognition, 184–5, 321, 355–9, 387
 tests, 328–9, 457, 467, 471
 see also face recognition; object recognition; word recognition
recovery of function, 423–4
 age and, 433–4, 436
 aphasia, 286, 424, 432–41, 443
 explanations, 439–40, 442
 influences, 432–6
 language, 435, 440
 problems, 423, 435, 438
 rehabilitation, 442–5
reflexes, 6, 105–6, 118, 455
refractory period, 66–7
regional cerebral blood flow (rCBF), 31, 32, 178, 387, 415–17
rehabilitation, 442–5, 456
Reitan–Indiana Test Battery, 477
release of function, 16
representation, 133, 239, 245, 267, 284
repropagation, 67
resources, 485–91
resting potential, 65
reticular formation, 72, 83, 112, 348
retina, 76, 84, 93, 102, 103, 213
retrograde amnesia *see* amnesia
reward, 166, 189, 197, 203–4, 346, 359
Rey–O test, 457, 467–8, 483
rhinencephalon, 91
rhyme, 305, 307, 309
Ribot's law, 438
right-shift theory, 143–4
right-sided world hypothesis, 158
right ear advantage, 45–6, 430–1
right handedness, 266, 356, 435
- right hemisphere, 47, 127, 135–6, 227, 430
 emotion and, 355, 356, 357, 359–60
 interhemispheric transfer, 150–4
 language and, 129–31, 143, 155, 274, 276, 300, 310, 437
 mental rotation, 131–3
 neglect and, 244–5
 visuospatial ability, 129, 131–2, 133
 see also lateralization of function
rigidity, 254, 257, 258–9, 379
risk taking, 204
rivastigmine, 375–6
Rivermead Behavioural Memory Test, 457, 466–7, 477
RJ (patient), 441
ROB (patient), 328–9
Rolandic fissure, 86, 355, 411
rootlets/roots (spinal cord), 82–3
rostral (definition), 76
rostrum, 146, 147
RV (patient), 109
- saccades, 105
sacral vertebrae, 81
sadness, 43, 346–7, 351–2, 354, 358, 401
sagittal section, 78
satellite cells, 64
SB (patient), 212
scala tympani/scala vestibuli, 111, 112
scavenger cells, 64
schizophrenia, 27, 39, 43, 279, 393–8, 419, 464, 480
Schwann cells, 61, 64–5
scopolamine, 373, 389
scotoma, 106, 213–14
scrapie, 374
Seashore Rhythm Test, 457, 461, 469
seasonal affective disorder, 406
secondary memory, 321
secondary taste cortex, 115, 172–3
selective attention, 134, 135, 136, 180
semantic memory *see* memory
semantic processing, 295–7, 302, 316
semicircular canals, 111
senile dementia, 258
senile plaques, 367, 372
sensation, 2, 10
sensory aphasia *see* aphasia
sensory cortex, 93, 114
sentences, 276, 277, 294
septal nuclei, 91
septohippocampal system, 347–8, 415–19
sequencing, 178–9, 264, 265
serotonin, 71, 72, 255, 417
 depression, 403–4, 405, 406, 407
sex differences, 129, 133, 138–41, 174, 427, 428
sexual behaviour, 85, 348, 360
shape agnosia, 216
shape discrimination, 214, 221
shared-systems theory, 221–2
shock, 439
short-term memory *see* memory
sign language, 155, 290, 298–9

- signal-to-noise ratio, 24, 38
 signal impedance, 23
 singing, 137
 single-case study, 3, 12–19, 44, 129
 single participant research design, 17–18
 single photon emission CT (SPECT), 33–4
 Six Elements Test, 168, 179, 200
 skilled movement, 263
 skin conductance response, 189, 204, 206, 357
 skull, 7, 85, 95, 97, 128
 smell, 23, 29, 86, 89, 91, 173–4
 smiling, 356
 social behaviour, 166, 171, 192, 194–201, 204, 377–8
 social phobia, 407, 408, 411
 societies, 491
 sodium-potassium pump, 66
 sodium amyltal, 40, 142
 sodium ions/channel, 65, 66, 67, 68
 software, 489–90
 soma *see* cell body
 somatic marker, 188, 189, 203–4
 somatosensation, 40–1, 89, 114, 151, 175
 somatosensory agnosia, 215, 235
 somatosensory cortex, 86, 93, 114, 115, 166, 193, 235
 somatosensory system, 114, 120
 soul, 5–6
 sound agnosia, 89, 215, 234
 sound images, 9
 sound waves, 111–14
 source memory, 384
 sparing of function, 436–7
 spatial ability *see* visuospatial ability
 spatial acalulia, 137
 spatial memory, 340–2
 spatial neglect, 89, 93–4, 110, 235–48
 speech, 42, 433
 comprehension, 9, 129, 274, 275–6
 perception, 155, 457, 461, 469
 production, 8–9, 20, 129, 145, 274–6, 277, 282, 292–4
 spinal cord, 3, 7, 10, 70, 76, 80–3, 86, 95, 96
 spinal nerves, 82–3, 96
 splenium, 146, 147–9, 151, 221, 227
 split-brain operations, 12, 16, 146, 150
 split-brain patients, 46, 129, 145, 148–50, 153–4
 spongioblasts, 80
 spontaneous behaviour, 175–7
 Spot-the-Word test, 457
 SQUID, 29
 SSRIs, 413, 415
 staining, 6–7, 57
 Stanford Binet Intelligence Scale, 460
 stapes, 111, 112
 startle reflex, 112, 396
 stellate cells, 92
 stem cells, 57
 stereocilia, 112
 stereotactic coagulation, 257
 stimulus uncertainty, 26
 strategy formation, 177–80
 stria of Genari, 106
 striate cortex, 76, 86, 92–3, 106, 108, 212–14
 striatum, 255, 260, 262, 413
 stroke *see* cerebrovascular accident
 structural development, 428
 strychnine, 71
 subarachnoid haemorrhage, 95, 99, 100
 subarachnoid space, 95–6, 98, 100
 subcortical dementia, 379, 390
 subcortical structures, 346–54, 396–7
 subdural haematoma, 98, 100
 subdural space, 95, 98
 substantia innominata, 92
 substantia nigra, 72, 84, 255, 378
 suicide, 403
 sulci, 82, 86, 95, 128, 381
 superior colliculi, 84, 105–6, 136
 superior olivary complex, 112
 supervisory attentional system, 202–3
 supplementary motor cortex, 119–20, 157, 165–6, 172, 178, 195
 surface dyslexia, 20, 301–2, 316, 378
 surprise, 347, 351
 sustained attention, 134–5, 136
 swearing, 261, 262
 Sydenham's chorea, 260
 syllogistic reasoning tasks, 190–1
 Sylvian fissure, 86, 127, 279, 381, 397–8
 symbol recognition, 49–51
 symptom provocation, 408, 413
 synapse, 59, 63, 65, 68–70, 83, 323, 424
 synaptic formation, 424, 425, 426
 synaptic knob, 59, 66, 68, 70, 83
 synaptic shedding, 425, 426
 synaptic vesicles, 59, 68, 70

 2-deoxyglucose, 32
 tachistoscope, 46, 149
 tactile agnosia, 149, 213, 214–15, 235
 tactile discrimination, 455
 tactile sensation, 114
 Tan, 8–9, 13, 274
 taste, 114–16, 172–3, 174
 taste buds, 114
 tectopontine axons, 105
 telegraphic speech, 283, 285
 telencephalon (endbrain), 80
 temporal lobe/cortex, 39, 86–8, 92, 94, 100, 130, 137, 172, 174, 226, 245, 274, 278, 377, 381, 397, 408
 memory and, 327, 330–1, 335–6, 400
 temporal summation, 69
 terminal button, 59, 66, 68, 70, 83
 tertiary zones, 201
 test battery, 456–62, 470
 Test of Everyday Attention, 457, 469, 477
 testosterone, 156
 thalamocortical connections, 93, 114
 thalamotomy, 257
 thalamus, 16, 84–5, 93, 112, 114, 135, 266–7, 286, 326–8, 347–8, 396, 412
 theory of mind, 191–4, 300
 theta wave, 23

- thiamine deficiency, 327, 380, 381
 thoracic vertebrae, 81
 thought disorders, 393–400
 threshold of excitation, 66, 69
 thrombosis, 99
 tickling, 120
 tics, 261
 tissue radiography, 30
 Token Test, 457, 470
 tonic-clonic epilepsy, 399, 400
 Topographic Recognition Memory Test, 466
 Tower of Hanoi task, 388, 457, 476
 Tower of London task, 168, 169, 178, 189, 388, 427, 457
 Tpt, 127–8
 tracts, axonal, 61, 63
 trail making, 461
 trans-cranial magnetic stimulation, 42–5
 transcortical aphasia, 279, 281, 285
 transient ischaemic attack, 99
 tranlycypromine, 404, 405
 tremor at rest, 254, 257
 tricyclic antidepressants, 404, 405, 406
 trigeminal odours, 173–4
 tryptophan, 71, 403, 405
 tuberculosis 406
 tumour, 99, 100–1, 179, 268, 439
 two visual systems theory, 107–9
 tympanic membrane, 111, 112
 tyramine-cheese reaction, 404
 tyrosine, 71
- umami, 114
 unilateral spatial neglect, 235–48
 unipolar depression, 401, 402, 403, 404
 utilization behaviour, 180–1, 203
- vagus nerve, 189–90
 valence hypothesis, 359–60
 Valium, 414
 vascular dementia, 27, 376–7, 390
 venous sinuses, 98
 ventral (definition), 76
 ventral horns, 83, 118
 ventricles (brain), 2, 5–6, 16, 80, 83–4, 96, 101, 381, 397, 402
 ventriculomegaly, 101
 verbal fluency 171, 175, 181, 464
 verbal IQ, 436–7, 457, 459–60, 464
 vermis, 85
 vertebrae, 81–2
 vertebral artery, 97–8
 vestibular apparatus/membrane, 111
- vicarious functioning, 436–7
 vigilance, 469
 viral dementia, 381
 visual agnosia *see* agnosia
 visual cortex, 86, 93, 103, 105–7, 124, 299
 visual field studies, 45, 46, 102–3, 132, 135–6, 278
 Visual Object and Space Perception Battery, 457, 472
 visual system, 46–7, 76, 94, 102–11, 113, 166, 213
 - blindness, 106, 212–14, 216
 - damage, 105–9
 - eye, 102–5, 165, 244, 262
 - functioning (theories), 107–11
 - see also* optic entries
- visual word form dyslexia, 301–2
 visuospatial ability, 109, 124, 138–40, 157, 379, 433, 457
 - handedness and, 142–3
 - right hemisphere, 129, 131–3, 274
 - tests of, 470–2
- visuospatial sketchpad, 186, 322
 voluntary movement, 93–4, 118, 119, 120, 172, 254, 263, 455
 VP (patient), 154
- Wada test, 12, 40–1, 142
 walking, 118, 262
 Warrington Recognition Memory Test, 328–9, 457
 websites, 489–90
 Wechsler Adult Intelligence Scale, 142, 187, 456–61, 463–5, 469, 474, 480–2
 Wechsler Intelligence Scale for Children (WISC), 138, 444, 459
 Wechsler Memory Scale, 336, 457, 461, 465–6, 482, 483
 Wechsler Test of Adult Reading, 457
 Wernicke's aphasia *see* aphasia
 Wernicke's area, 9, 35, 44, 76, 89, 100, 129, 143, 274–6, 279, 282, 284, 290, 291, 299, 309
 Western Aphasia Battery, 457, 469
 white matter, 63, 84, 85, 106, 227
 Wilson's disease, 120, 254, 262
 Wisconsin Card Sorting Task, 167–8, 171, 176, 177–8, 186, 205, 457, 465
 word-association tasks, 130
 word recognition, 49–51, 129–30, 292, 298
 word fragment completion task, 184–5
 working memory *see* memory
 writer's cramp, 261
 writing, 137, 400
 - dysgraphia, 279, 316–17, 433
- X-ray CT, 30
- Zaslavsky (Z), 13–14
 zygomatic muscle, 356